

Sensorless Control of DC Drive Using Artificial Neural Network

Pavel Brandstetter

VSB-Technical University of Ostrava, Department of Electronics, 17. listopadu
15/2172, 70833 Ostrava-Poruba, Czech Republic
e-mail: pavel.brandstetter@vsb.cz

Abstract: The paper deals with the application of an artificial neural network in the speed control of the DC drive without a speed sensor. The sensorless control structure of the DC drive contains the feedforward artificial neural network for speed estimation. The sensorless DC drive was simulated in program Matlab with Simulink toolbox. The main goal was to find the simplest artificial neural network structure with minimum number of neurons, but simultaneously good control characteristics are required. Despite the used neural network, which is very simple, it was achieved satisfactory results. The simulation results were confirmed by measurement of important quantities on a laboratory stand with the DC drive.

Keywords: DC drive; artificial neural network; sensorless control; speed estimation

1 Introduction

Nowadays, modern digital signal processors enable the development of electrical drives with high dynamic performance using new control methods that include soft computing methods. The soft computing methods include fuzzy logic, artificial neural networks, evolutionary algorithms and their combinations [1].

The basic function of a variable speed drive is to control the flow of energy from the mains to the process. Energy is supplied to the process through the motor shaft. Two physical quantities describe the state of the shaft: torque and speed. To control the flow of energy we must control these quantities [2-5].

Initially, DC motors were used for variable speed drives because they could easily achieve the required speed and torque without sophisticated electronics. The conventional DC motor drive continues to take a large share of the variable-speed drive market. However, it is expected that this share will very slowly decline, but there are some companies that produce DC drives.

The power part of the DC drive consists of power converter and the DC motor (DCM). In the case of AC mains a controlled rectifier is used to obtain a DC voltage. When a fixed DC supply is available, the DC to DC converter can be used. For the control of the DC motor, the constant DC voltage is transformed into an adjustable voltage u_a to control the speed of the DC motor. The armature current i_a and excitation current i_e are controlled by current controllers.

3 Sensorless Control Using Artificial Neural Network

The speed controller processes the control deviation between the reference speed ω_{mref} and the actual speed ω_m which is obtained by the speed sensors such as tachogenerator or incremental sensor. However, these sensors can cause a variety of problems. The main reasons for the development of sensorless drives are: reduction of hardware complexity and cost, increasing mechanical robustness, reliability.

In the case that speed or position sensor is not used in the control structure of an electrical drive, this drive has an attribute sensorless drive. For the control of remaining quantities, other sensors are however necessary which are used for a measurement of motor currents and voltages. The speed estimation methods can be classified into conventional, based on mathematical model of the electrical motor, or based on artificial intelligence [10-14].

The essence of the model based methods is the use of a particular algorithm for calculation of the speed and rotor position from known or measured variables such as motor currents and voltages. The methods based on artificial intelligence use mostly different types of artificial neural networks.

For a design and implementation of the speed estimator, it is necessary to choose the suitable structure of the artificial neural network (ANN) with appropriate input quantities, which will realize the views defined as follows:

$$\omega_{m(k)} = \mathbf{f}[i_{a(k)}, i_{a(k-1)}, u_{a(k)}, u_{a(k-1)}, \mathbf{w}] \quad (1)$$

where \mathbf{f} is the activation function and \mathbf{w} is a vector of weighting and threshold coefficients.

First it is necessary to design right structure of the artificial neural network and it is also important to determine such inputs to ANN, which are available in structure of the speed control and from which is able to estimate a rotor speed of the DC motor. A recommended method for determination of ANN structure does not exist, so the final ANN was designed by means of trial and error.

The main goal was to find the simplest neural network with good accuracy of speed estimation. This is the key for industry use of the artificial neural networks.

4 Structure of Artificial Neural Network

The artificial neural network is a massively parallel, non-linear adaptive system containing highly interacting elements called neurons or perceptrons. The artificial neural networks are based on crude models of the human brain and contain many artificial neurons linked via adaptive interconnections (weights). They are adaptive function estimators which are capable of learning the desired mapping between the inputs and the output of the system.

The artificial neural networks usually must learn the connection weights from available training patterns. Performance is improved over time by iteratively updating the weights in the network. The learning and adapting capability of neural networks makes them ideal for control purposes. The ANN can be successfully applied even if the motor which is to be controlled and the load parameters are unknown.

For realization of a control system with an ANN speed estimator, the feedforward artificial neural network was used which was trained off-line by set of corresponding input-output pairs of controlled system. The weights of the ANN can be then adjusted via the so-called backpropagation algorithm using Levenberg-Marquardt method to minimize the error.

For the ANN speed estimator, it was tested various structures of the artificial neural network for different speed areas, for example 4-22-1, 4-11-1, 4-5-1, 4-2-1, 4-5-5-1, 4-5-2-1. The simulation results of many structures were not so good, especially estimated signal (output of the ANN speed estimator) contained higher ripple. Finally, a four layer ANN 4-3-2-1 was used which contains three neurons in the first hidden layer with tanh activation function; two neurons in the second hidden layer with tanh activation function and one neuron in output layer with linear activation function (see Fig. 2).

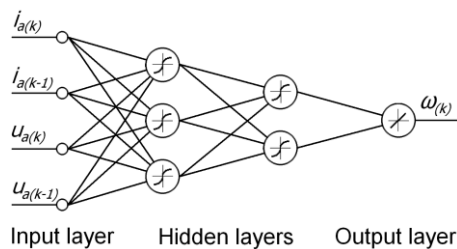

Figure 2
Structure of ANN speed estimator

The ANN has four inputs for quantities $i_{a(k)}$, $i_{a(k-1)}$, $u_{a(k)}$, $u_{a(k-1)}$ (armature current and voltage of the DC motor) and output $\omega_m(k)$ (mechanical speed). It is obvious that the structure of the ANN speed estimator is very simple. However, good results of important drive quantities are achieved.

5 Simulation Results

As it was mentioned above, the sensorless DC drive was simulated in program Matlab - Simulink. The parameters of the DC motor are: $P_n = 2.9$ kW, $U_{an} = 220$ V, $I_{an} = 21.6$ A, $\omega_{mn} = 1400$ rpm, $J = 0.24$ kgm².

For the control quality evaluation of the sensorless DC drive, it is important to assess the speed time course in different situations. The simulation was performed for the reference speeds which represent two speed areas: area of low speed ($\omega_{mref} = \pm 100$ rpm), area of very low speed ($\omega_{mref} = \pm 10$ rpm). The estimated speed ω_{m_est} is used as the feedback signal for the speed control.

The first reference speed is changed from 100 rpm to -100 rpm. During this operation the DC drive works without load. Reference, actual and estimated speed responses of the DC drive are shown in Fig. 4, 5.

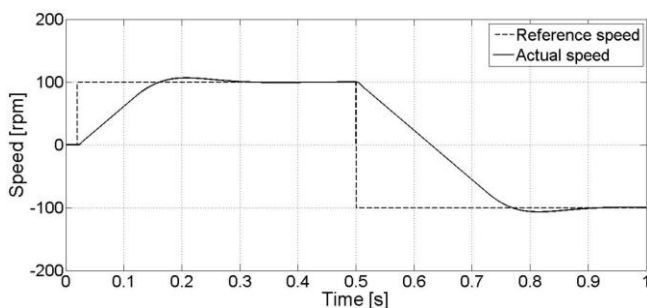

Figure 4

Sensorless control of the DC drive without load, reference and actual speed response

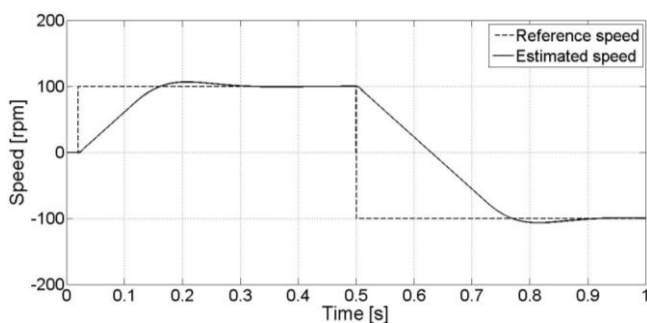

Figure 5

Sensorless control of the DC drive without load, reference and estimated speed response

Figure 6 shows details about speed of 100 rpm. The difference between actual and estimated speed is shown in Fig. 7.

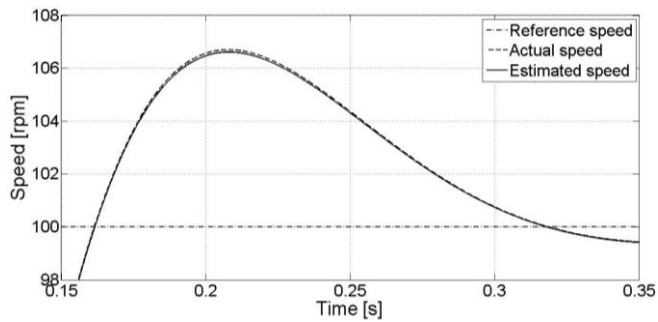

Figure 6

Actual and estimated speed response, details about speed of 100 rpm

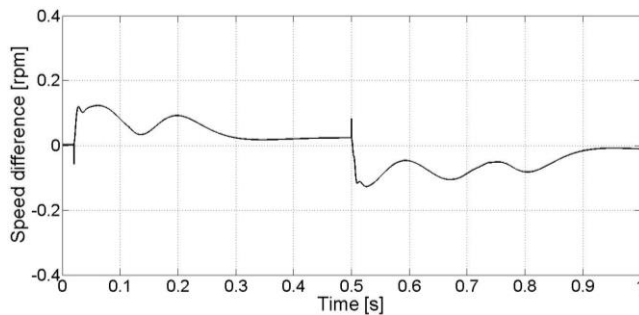

Figure 7

Difference between actual and estimated speed response

The second reference speed is changed from 10 rpm to -10 rpm. During this operation the DC drive works again without load. Reference, actual and estimated speed responses of the DC drive are shown in Fig. 8, 9.

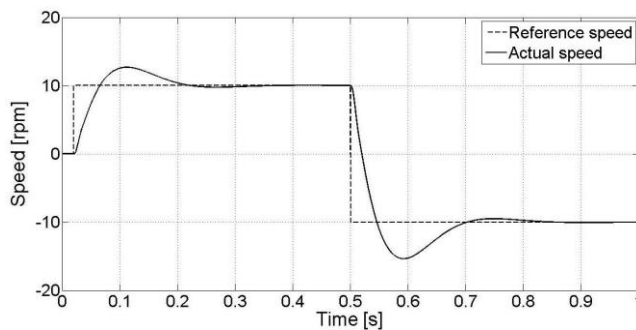

Figure 8

Sensorless control of the DC drive without load, reference and actual speed response

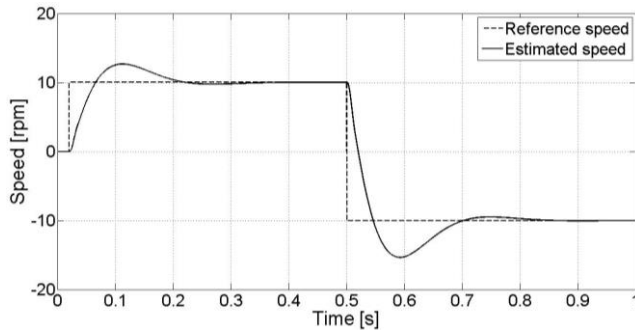

Figure 9

Sensorless control of the DC drive without load, reference and estimated speed response

Figure 10 shows details about speed of 10 rpm. The difference between actual and estimated speed is shown in Fig. 11.

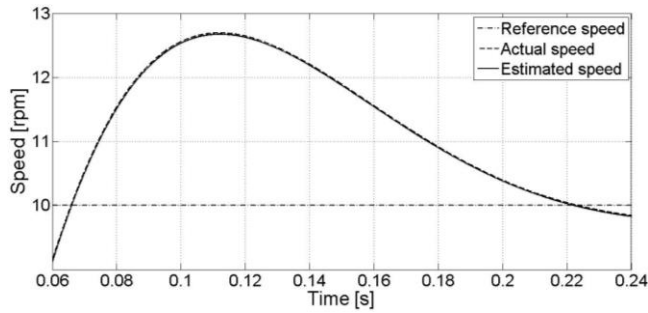

Figure 10

Actual and estimated speed response, details about speed of 10 rpm

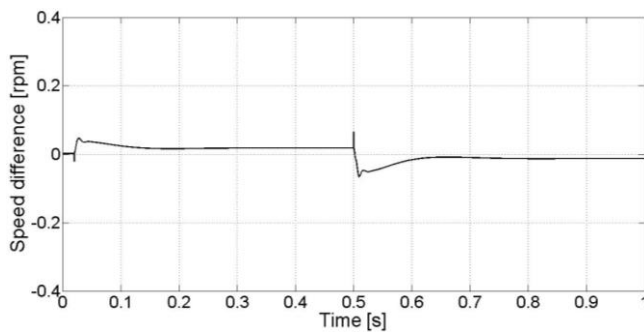

Figure 11

Difference between actual and estimated speed response of the DC drive without the load

The third reference speed is changed from 100 rpm to -100 rpm. During this operation the DC drive works with load jump $T_L = 5$ Nm in the time interval 0.6-1.0 s. Reference, actual and estimated speed responses of the DC drive are shown in Fig. 12, 13. Figure 14 shows details about speed of 100 rpm.

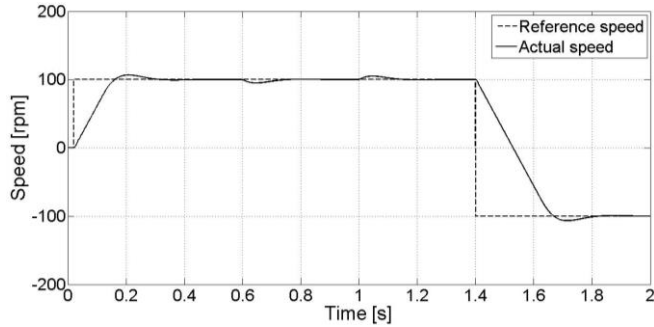

Figure 12

Sensorless control of the DC drive with the load, reference and actual speed response

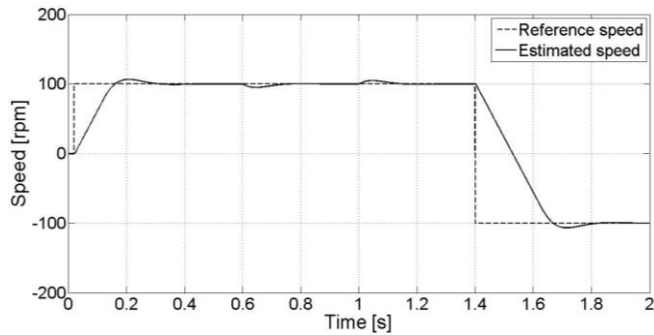

Figure 13

Sensorless control of the DC drive with the load, reference and estimated speed response

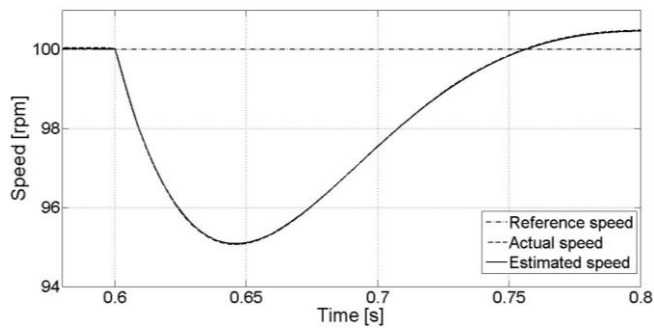

Figure 14

Actual and estimated speed response, details about speed of 100 rpm

The difference between actual and estimated speed is shown in Fig.15.

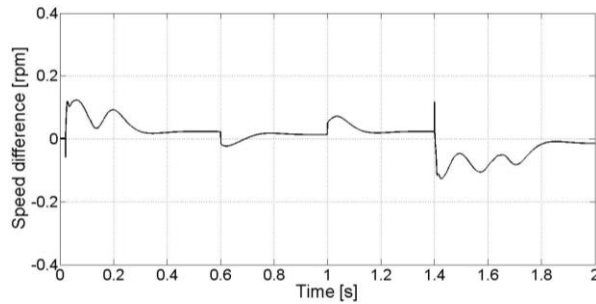

Figure 15

Difference between actual and estimated speed response of the DC drive with the load

6 Laboratory Stand

To verify the simulation models and principles as well as sensorless control of the DC drive using ANN speed estimator, an experimental laboratory stand with the DC drive supplied by DC-DC converter was realized (see Fig. 16).

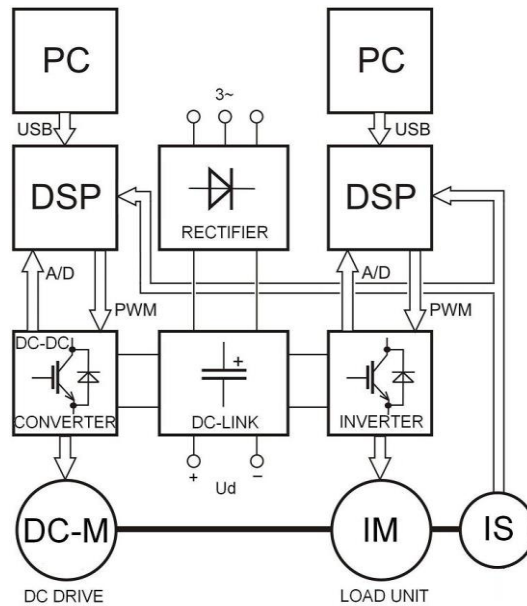

Figure 16

Laboratory stand with the DC drive and load unit

This laboratory stand allows research of new control methods and solution of problems of variable speed drives with DC and AC motors that contribute to increasing the efficiency of electrical products and reducing energy consumption. The active load unit is realized as the vector-controlled induction motor drive which allows choosing different load characteristics, for example the load with constant torque, fan and lift characteristics. The basic parts are machine set with DC motor and AC machine, DC-DC converter, voltage inverter, control systems with DSP, personal computer and the necessary measuring instruments.

The DC motor and induction machine IM with the incremental sensor IS are located on a common shaft. Each machine is connected to a separate converter with voltage intermediate circuit and control system with DSP.

To increase the efficiency of the drive at loading, a concept with a common DC-link was chosen, which allows the use of regenerative energy for the DC drive, without having to use a transistor switch and resistor in voltage DC-link. The electric machines are connected mechanically by a coupling and assembled to the frame. They form a machine set (see Fig. 17).

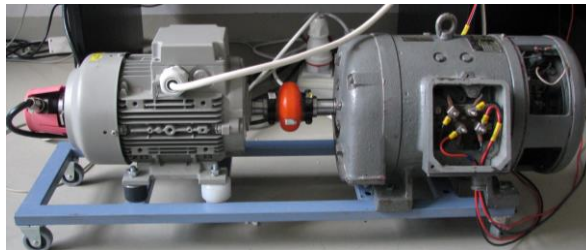

Figure 17

Machine set with the DC motor and induction machine

In the control systems with digital signal processor, control algorithms are implemented. An incremental encoder that generates 2048 pulses per revolution forms with the IM a compact unit. In the control system, a Texas Instrument TMS320F28335 digital signal processor is used. The base board with the DSP also contains a transducer of the serial line to USB; therefore, communication and data acquisition uses the USB interface. The control set also includes a power supply and development software Code Composer Studio™ version 4.

7 Data Acquisition System

For implementation of neural speed estimator onto real electrical drive it is necessary to obtain such training data, which determine the desired behaviour of artificial neural network (see Fig. 18). Data acquisition system (DAQ) was

developed for fast transfer of training data from DSP system to PC. Data acquisition system is based on measuring card NI-DAQ 6024E by National Instruments.

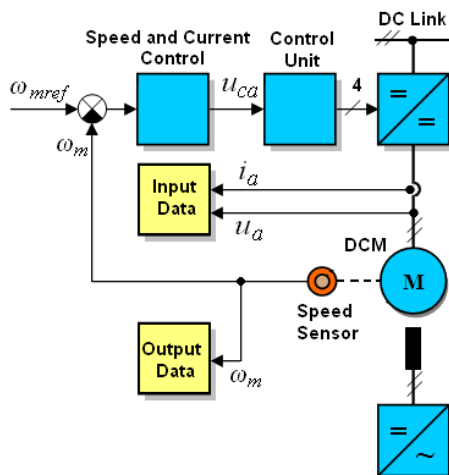

Figure 18

Control structure for the collection of training data

Training patterns were obtained from the real drive with the DC motor. Armature current and voltage values, which were used as the input values of the artificial neural network, were measured using current and voltage sensors. Using the incremental sensor, which was a part of the drive during the training data collection process, the desired neural network outputs (mechanical speed) were obtained. In order for the neural network to be able to generalize, i.e. to be able to generate the correct estimated speed of the DC motor, even for input samples that were never available during the training phase, it is necessary to gather a large amount of training data. As far as magnitude is concerned, it represents tens of thousands of data, which could not be stored in the signal processor memory. This data had to be transferred to a personal computer for neural network training. For this reason, a 6024 E National Instruments measuring card was used for the data collection process.

A multifunction DAQ NI – 6024E card is a plug-in measuring card for personal computers using a PCI interface. This card is fitted with a 12 bit A/D converter working with a sampling frequency up to 200 kHz. The card is further fitted with two D/A channels with 12 bit resolution, which may be operated with a frequency of 10 kHz. In addition to these D/A and A/D converters, the card offers 8 digital I/O pins, 2 counters/timers with 24-bit resolution and 100 kHz/20 MHz speeds.

The measuring card was used in the LabVIEW program, which was used to create measuring software for training data collection.

For the purpose of gathering training samples, we also had to create a program for DSP, which changes the speed of the DC motor at desired and suitable moments. The selection, number and rate of change of the preset values are the key factors for achieving a properly functioning neural network.

A brief summary of the training data collection process and the training phase for the application of the speed estimator with neural network is as follows:

- Creation of a program in DSP to adequately change the desired speed of the DC motor.
- Creation of a program in the LabVIEW environment enabling training data collection using NI -DAQ 6024E measuring card.
- Measurement of the required training patterns.
- Preparation of measured data for import into Matlab environment. Most importantly, modification of previous input values of the neural network, etc.
- The process of neural network training using the Levenberg - Marquardt algorithm, which was performed in Matlab environment using Neural Network Toolbox.
- Export of parameters of the trained neural network from Matlab and subsequent implementation into DSP.

8 Experimental Results

In this chapter, time courses of important quantities of the electrical drive with the DC motor 2.9 kW are presented. Experimental results are obtained when speed control loop operates using estimated speed. The real value of mechanical speed which is obtained from incremental encoder is used for comparison of the actual and estimated speed.

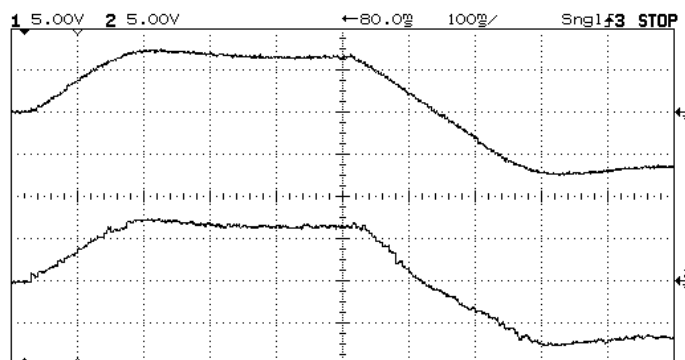

Figure 19

Time courses of the actual speed (Ch1) and estimated speed (Ch2), run-up to 100 rpm and reversion to -100 rpm without load (speed scale 1 d \approx 75 rpm)

The first testing regime is run-up to 100 rpm and reversion to -100 rpm. The second testing regime is run-up to 10 rpm and reversion to -10 rpm. During this operation the DC drive works without load.

The reference and actual speed responses of the DC drive are shown in Fig. 19 and Fig. 20. These speed responses show good correlation of speed magnitudes.

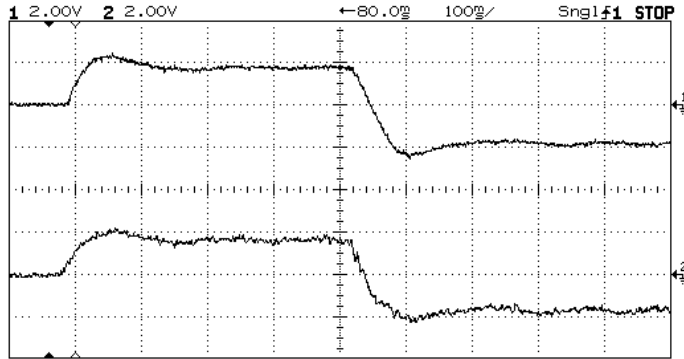

Figure 20

Time courses of the actual speed (Ch1) and estimated speed (Ch2), run-up to 10 rpm and reversion to -10 rpm without load (speed scale 1 d \approx 12 rpm)

The third testing regime was aimed on dynamic response to load jump at constant speed. Experimental results for the load jump $T_L = 5$ Nm and speed $\omega_m = 100$ rpm are shown in Fig. 21 and Fig. 22.

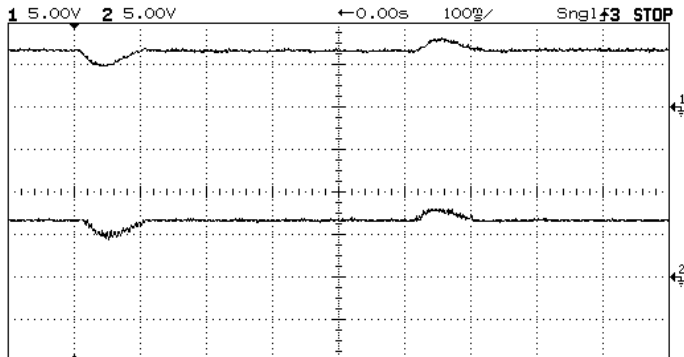

Figure 21

Time courses of the actual speed (Ch1) and estimated speed (Ch2), constant speed $\omega_m = 100$ rpm and load torque jump $T_L = 5$ Nm (speed scale 1 d \approx 75 rpm)

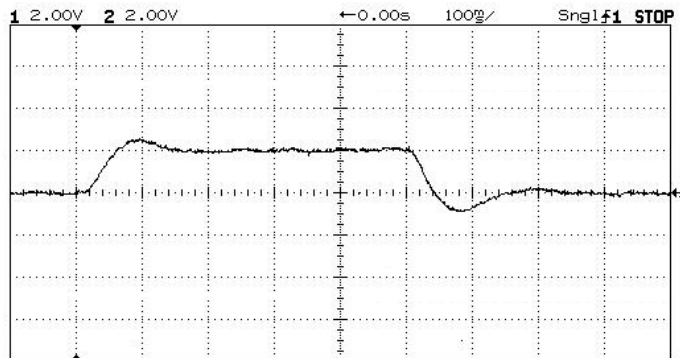

Figure 22

Time courses of the armature current (Ch1), constant speed $\omega_m = 100$ rpm
and load torque jump $T_L = 5$ Nm (current scale 1 d ≈ 4 A ≈ 5 Nm)

Conclusions

In the paper, the sensorless control structure of the DC drive is presented. The speed estimation is carried out by the feedforward neural network. The structure of the ANN speed estimator is very simple which is important for the practical implementation into DSP control system. The paper contains interesting simulation and experimental results. The presented ANN speed estimator has expected properties in steady state and also in transient states which were confirmed by experimental measurements on the laboratory stand with DC drive.

Acknowledgement

The article has been elaborated in the framework of the IT4Innovations Centre of Excellence project, reg. no. CZ.1.05/1.1.00/02.0070 supported by Operational Programme 'Research and Development for Innovations' funded by Structural Funds of the European Union and state budget of the Czech Republic and in the framework of the project SP2014/85 which was supported by VSB-TU of Ostrava.

References

- [1] M. Norgaard: Neural Networks for Modelling and Control of Dynamic Systems, Springer-Verlag London, 2000
- [2] P. Palacky, P. Hudecek, A. Havel: Real-Time Estimation of Induction Motor Parameters Based on the Genetic Algorithm, International Joint Conference CISIS'12-ICEUTE'12-SOCO'12 Special Sessions, Advances in Intelligent Systems and Computing, Vol. 189, 2013, pp. 401-409
- [3] V. Sladecek, P. Palacky, D. Slivka, M. Sobek: Influence of Power Semiconductor Converters Setup on the Quality of Electrical Energy from Renewable Sources, Proc. of the 11th International Scientific Conference Electric Power Engineering, Brno, Czech Republic, 2010, pp. 527-531

-
- [4] P. Simonik, A. Havel, M. Hromjak, P. Chlebis: Active Charging Stations for Electric Vehicles Charging, Proc. of Progress in Electromagnetics Research Symposium (PIERS 2012) Kuala Lumpur, Malaysia, 2012, pp. 995-998
- [5] P. Vas: Artificial-Intelligence-based Electrical Machines and Drives, Oxford science publication, 1999
- [6] M. T. Hagan, H. B. Demuth, O. De Jesus: An introduction to the use of neural networks in control systems, International Journal of Robust and Nonlinear Control, Vol. 12, No. 11, 2002, pp. 959-985
- [7] P. Fedor, D. Perdukova: Energy Optimization of a Dynamic System Controller, International Joint Conference CISIS'12-ICEUTE'12-SOCO'12 Special Sessions, Advances in Intelligent Systems and Computing, Vol. 189, 201, pp. 361-369
- [8] Ch. H. Lin: A Novel Hybrid Recurrent Wavelet Neural Network Control for a PMSM Drive Electric Scooter Using Rotor Flux Estimator, International Review of Electrical Engineering-IREE, Vol. 7, No. 3, 2012, pp. 4486-4498
- [9] L. Qin, X.C. Zhou, P.J. Cao: New Control Strategy for PMSM Driven Bucket Wheel Reclaimers using GA-RBF Neural Network and Sliding Mode Control, Elektronika Ir Elektrotehnika, Vol. 18, No. 6, 2012, pp. 113-116
- [10] S. M. Gadoue, D. Giaouris, J. W. Finch: Sensorless Control of Induction Motor Drives at Very Low and Zero Speeds Using Neural Network Flux Observers, IEEE Transactions on Industrial Electronics, Vol. 56, No. 8, 2009, pp. 3029-3039
- [11] V. Smidl, Z. Peroutka: Advantages of Square-Root Extended Kalman Filter for Sensorless Control of AC Drives, IEEE Transactions on Industrial Electronics, Vol. 59, No. 11, 2012, pp. 4189-4196
- [12] M. Kaminski, M. Dybkowski: Analysis of the Sensorless Vector Control of Induction Motor with MRAS(CC) Estimator and Neural Model Applied for Speed Calculation, Przegląd Elektrotechniczny, Vol. 88, No. 4B, 2012, pp. 116-121
- [13] T. Orłowska-Kowalska, M. Kaminski: FPGA Implementation of the Multilayer Neural Network for the Speed Estimation of the Two-Mass Drive System, IEEE Transactions on Industrial Informatics, Vol. 7, No. 3, 2011, pp. 436-445
- [14] P. Girovsky, J. Timko, J. Zilkova: Shaft Sensor-less FOC Control of an Induction Motor Using Neural Estimators, Acta Polytechnica Hungarica, Vol. 9, No. 4, 2012, pp. 31-45
- [15] M. H. Beale, M. T. Hagan, H. B. Demuth: Neural Network Toolbox™, User's Guide, The MathWorks, Inc., 2012