



Aalborg Universitet

AALBORG UNIVERSITY  
DENMARK

## Analytical Performance Verification of FCS-MPC Applied to Power Electronic Converters

*A Model Checking Approach*

Novak, Mateja; Dragicevic, Tomislav; Blaabjerg, Frede; Nyman, Ulrik Mathias

*Published in:*

Proceedings of 2017 IEEE 18th Workshop on Control and Modeling for Power Electronics (COMPEL)

*DOI (link to publication from Publisher):*

[10.1109/COMPEL.2017.8013279](https://doi.org/10.1109/COMPEL.2017.8013279)

*Publication date:*

2017

*Document Version*

Accepted author manuscript, peer reviewed version

[Link to publication from Aalborg University](#)

*Citation for published version (APA):*

Novak, M., Dragicevic, T., Blaabjerg, F., & Nyman, U. M. (2017). Analytical Performance Verification of FCS-MPC Applied to Power Electronic Converters: A Model Checking Approach. In *Proceedings of 2017 IEEE 18th Workshop on Control and Modeling for Power Electronics (COMPEL)* IEEE Press. IEEE Workshop on Control and Modeling for Power Electronics (COMPEL) <https://doi.org/10.1109/COMPEL.2017.8013279>

### General rights

Copyright and moral rights for the publications made accessible in the public portal are retained by the authors and/or other copyright owners and it is a condition of accessing publications that users recognise and abide by the legal requirements associated with these rights.

- ? Users may download and print one copy of any publication from the public portal for the purpose of private study or research.
- ? You may not further distribute the material or use it for any profit-making activity or commercial gain
- ? You may freely distribute the URL identifying the publication in the public portal ?

### Take down policy

If you believe that this document breaches copyright please contact us at [vbn@aub.aau.dk](mailto:vbn@aub.aau.dk) providing details, and we will remove access to the work immediately and investigate your claim.

# Analytical Performance Verification of FCS-MPC Applied to Power Electronic Converters: A Model Checking Approach

Mateja Novak, Tomislav Dragicevic, Frede Blaabjerg  
Department of Energy Technology  
Aalborg University  
Aalborg, Denmark  
Email: nov@et.aau.dk, tdr@et.aau.dk, fbl@et.aau.dk

Ulrik Mathias Nyman  
Department of Computer Science  
Aalborg University  
Aalborg, Denmark  
Email: ulrik@cs.aau.dk

**Abstract**—Since the introduction of finite control set model predictive control (FCS-MPC) in power electronics the algorithm has been missing an important aspect that would speed up its implementation in industry: a simple method to verify the algorithm performance. This paper proposes to use a statistical model checking (SMC) method for performance evaluation of the algorithm applied to power electronics converters. SMC is simple to implement, intuitive and it requires only an operational model of the system that can be simulated and checked against properties. Device under test for control algorithm application in this paper is a standard 2-level voltage source converter (VSC) with LC output filter used for uninterruptible power supply (UPS) systems. The performance of control algorithm is verified using the UPPAAL SMC toolbox and the behavior is compared to simulation results obtained from equivalent MATLAB/Simulink model and measurements from experimental set-up. Performance results are presented in terms of probabilities with corresponding uncertainties for calculated difference between the reference capacitor voltage value and the measured output voltage, and a simple moving average value. Algorithm's performance is tested with parameter uncertainties introduced in the model as well.

## I. INTRODUCTION

Rapid development of the digital control systems and exponential rise of their computing power has led to emergence of new control algorithm designs such as model predictive control (MPC) in various sectors of the industry [1]. Compared to the traditional control algorithms based on linear or hysteresis controllers, the MPC concept has an intuitive design methodology and it suits the non-linear systems. Constraints of the system and multiple objectives can simply be implemented but with the cost of higher calculation time compared to the linear control. Nevertheless the computing power of today's commercially available DSP's is sufficient for execution of large number of calculations. Therefore, main obstacle preventing a wide spread implementation of MPC algorithms to power converters is the non-existence of tools for the stability and performance evaluation, which is mandatory before any application in industry [1]–[4]. Stability and performance evaluation have to prove that below all transients the total harmonic distortion (THD) factor of the converter current and voltage will stay under the maximum allowed values defined

in application standards. Transient system performance should also be evaluated to ensure the stability. Well established methods for linear system stability and performance evaluation can not be used and a closed loop stability analysis is typically very complex. Ref. [5] presents an attempt to solve this issue, yet the method remains quite complicated as it is based on nonlinear control theory. The developed method should be simple and intuitive like the control design itself so that new MPC control algorithms could easily and quickly be verified for various applications. SMC approach could offer the needed simplicity and at the same time be a powerful tool to evaluate the behavior of the system. This approach has been successfully used in various industrial systems e.g. sensor networks and communication systems, aeronautic and automotive embedded systems to solve problems that are beyond the scope of classical formal techniques [6]–[8], and this method is applied in this paper as well.

UPPAAL SMC toolbox for model checking is appropriate for systems that can be modeled as a collection of non-deterministic processes with finite control structure and real-valued clocks that can evolve with rates specified by differential equations [9]. It can validate the performance of a deterministic or stochastic controller in a stochastic environment and run several consecutive simulations very fast in order to estimate the probability of the specified event with confidence levels and its probability distribution. The toolbox allows the user to visualize the results in the form of probability distributions, evolution of the number of runs with timed bounds and computation of expected values. Some successful implementations of SMC with UPPAAL toolbox include applications like schedulability analysis and quantitative aspects of scheduling systems as well as performance evaluation of controller strategies [6]–[10]. These facts make the UPPAAL SMC toolbox a very promising candidate for another field of implementation - the analytical performance verification of FCS-MPC algorithms in power electronics. Using SMC, the probability of system state variables staying within certain boundaries during transitional states could easily and quickly be assessed.

The paper is structured as follows: in first section the state-space equations of the system model are presented along with the control algorithm to be tested. The cost function is defined and the principle for weighting factor selection is explained. Section III gives an insight into the SMC approach and why it can be used to perform a performance validation of a FCS-MPC algorithm. In Section IV the FCS-MPC algorithm is first tested in MATLAB/Simulink simulation and then on an equivalent experimental set-up. Finally, the algorithm performance is verified in UPPAAL SMC for transient load changes using UPPAAL SMC's Verifier toolbox. The results are presented graphically and summed up in a table of tested query results. In the last section, conclusions are drawn from obtained results.

## II. SYSTEM MODEL

The power converter selected for demonstration of the SMC approach is a two-level VSC with LC output filter used for UPS application which is connected to a linear load [11] (see Fig. 1 and Fig. 2). Converter control is based on the following finite control set MPC (FCS-MPC) algorithm:

- 1) Measurement of the converter output current i.e. inductor current ( $i_f$ ), capacitor voltage ( $v_c$ ) and load current ( $i_o$ )
- 2) Voltage prediction for the next sampling instant for all possible switching states
- 3) Cost function evaluation for each prediction
- 4) Selection of the switching vector  $S_{abc}$  defining the converter output vector ( $v_i$ ) that minimizes the cost function
- 5) Application of the selected switching state

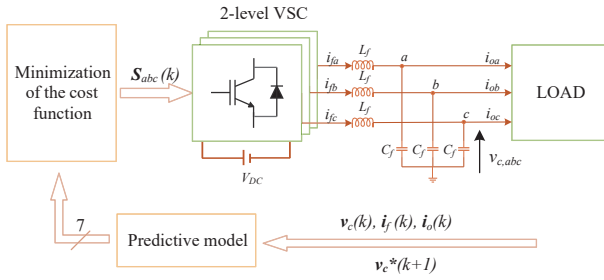

Fig. 1. Simplified scheme of model predictive control for 2-level VSC

Eight possible output vectors  $V_i, i \in [0..7]$  with the switching combinations indicating whether the positive  $p$  ( $V_{DC}$ ) or negative  $n$  ( $-V_{DC}$ ) potential is connected to the converter phase voltage output  $V_i (V_{a0}, V_{b0}, V_{c0})$  are shown in Fig. 2. The logic behind the switching vectors  $S_{abc} = S_a, S_b, S_c$  is the following:

$$S_x = \begin{cases} 1, & \text{if } S_{1x} \text{ is on and } S_{2x} \text{ is off} \\ 0, & \text{if } S_{1x} \text{ is off and } S_{2x} \text{ is on, } x \in a, b, c \end{cases} \quad (1)$$

Dynamics of the system can be expressed by two differential equations of the converter LC filter in stationary  $\alpha\beta$  frame,

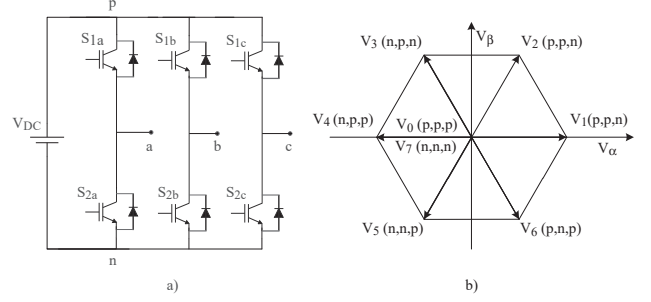

Fig. 2. (a) two-level VSC and (b) possible voltages generated by the converter

one for the converter current i.e. filter current  $i_{f\alpha\beta}$  and the second one for the converter output voltage  $v_{i\alpha\beta}$ :

$$i_{f\alpha\beta} = C \frac{dv_{c\alpha\beta}}{dt} + i_{o\alpha\beta} \quad (2)$$

$$v_{i\alpha\beta} = L \frac{di_{f\alpha\beta}}{dt} + v_{c\alpha\beta} \quad (3)$$

where:  $i_{o\alpha\beta}$  and  $v_{c\alpha\beta}$  are the load current and capacitor voltage in stationary  $\alpha\beta$  frame, while C and L correspond to filter capacitance and inductance. Following state-space representation of the model is obtained using (2) and (3):

$$\frac{d}{dt} \begin{bmatrix} i_{f\alpha\beta} \\ v_{c\alpha\beta} \\ i_{o\alpha\beta} \end{bmatrix} = \begin{bmatrix} 0 & -\frac{1}{L} & \frac{R_{load}}{L} \\ \frac{1}{C} & 0 & -\frac{1}{CR_{load}} \\ 0 & 0 & 0 \end{bmatrix} \begin{bmatrix} i_{f\alpha\beta} \\ v_{c\alpha\beta} \\ i_{o\alpha\beta} \end{bmatrix} + \begin{bmatrix} \frac{1}{L} \\ 0 \\ 0 \end{bmatrix} v_{i\alpha\beta} \quad (4)$$

The primary control objective of the algorithm is voltage control with minimization of switching frequency as secondary objective to limit commutation number of power switches. Therefore the cost function of the presented system is defined as:

$$g = (v_{\alpha}^* - v_{\alpha}^P)^2 + (v_{\beta}^* - v_{\beta}^P)^2 + \lambda_{sw} \cdot n^2 \quad (5)$$

where  $v_{c\alpha}^*$  and  $v_{c\beta}^*$  represent the real and imaginary parts of reference voltage vector  $v_c^*(k) = v_{c\alpha}^* + jv_{c\beta}^*$ ,  $v_{c\alpha}^P$  and  $v_{c\beta}^P$  the real and imaginary parts of predicted voltage vector  $v_c^P(k+1) = v_{c\alpha}^P + jv_{c\beta}^P$ ,  $\lambda_{sw}$  is the weighting factor of secondary objective and  $n$  is the number of switches that change state when the switching state  $S_x(k), x \in (a, b, c)$  is applied and it is calculated using the following expression:

$$n = |S_a(k) - S_a(k-1)| + |S_b(k) - S_b(k-1)| + |S_c(k) - S_c(k-1)| \quad (6)$$

As there are no analytical or numerical methods to determine the weighting factors, two performance values are defined: THD factor of the capacitor voltage and average switching frequency  $f_{sw_{avg}}$  calculated as a sum of the switching frequencies in each phase divided by the number of switches during the simulation time interval:

$$f_{sw_{avg}} = \sum_{i=1}^n \frac{f_{sw_{ai}} + f_{sw_{bi}} + f_{sw_{ci}}}{6} \quad (7)$$

TABLE I  
CALCULATED PERFORMANCE VALUES FOR SELECTED WEIGHTING  
FACTORS

$\lambda_{sw}$	THD	$f_{sw_{avg}}$ [kHz]
0	1.12%	18.3
0.1	1.45%	15.1
0.2	1.76%	13.2
0.3	2.24%	12.1
0.4	2.79%	11.9
0.5	3.38%	10.2

where  $i \in 1, 2, n$  represents the number of switches in each phase leg. The permitted THD factor for UPS is defined by the IEC 62040-3 standard, hence the selected weighting factor for switching frequency in the cost function should not produce a larger THD than defined in the standard [12]. Simulations in MATLAB/Simulink were performed for different values of  $\lambda_{sw}$  to calculate the performance values and the results are presented in Table I. The weighting factor  $\lambda_{sw} = 0.3$  was chosen to be used for further performance evaluation as it is giving a good trade-off between the output voltage harmonic distortion and the average switching frequency. For  $\lambda_{sw} = 0.3$  the average switching frequency was 5 kHz lower than for  $\lambda_{sw} = 0$  but with a cost of 1% higher THD factor of the output voltage. In discrete system model, predicted voltage vector  $v^P(k+1)$  is calculated using the measurements of converter output current, capacitor voltage and load current. To obtain discrete-time model of the system (4), forward Euler method was used. Simulations were performed in MATLAB/Simulink with the following system parameters:  $V_{DC} = 300$  V,  $L = 2.4$  mH,  $C = 25$   $\mu$ F,  $T_s = 25$   $\mu$ s,  $R_{load} = 60$   $\Omega$ ,  $\lambda_{sw} = 0.3$  and  $V_{cref} = 100$  V. This also corresponds to experimental set-up values. Weighting factor value was selected to keep the THD factor of the UPS output voltage in accordance with IEC 62040-3. Control algorithm in experimental set-up also includes a delay compensation as presented in [13].

### III. MODEL CHECKING USING UPPAAL SMC

SMC can be defined as a series of techniques that monitor several runs of the system with respect to some property and afterwards use the results from the statistics theory to get an overall estimate of the design correctness [9], [14]. For engineers the technique is easy to understand, to implement and to use, particularly for industrial applications. The probability distributions that drive the timed behaviors of the system can be specified through user interface and the estimated probability can be compared to a value or to another probability. In other words the system  $S$  will be simulated for a finite number of executions, resulting in a number of samples which will be used to test the specified hypothesis e.g. does the property  $\phi = \Delta V$  (system voltage deviation) stay under threshold  $\theta = 0.5$  % during the transient load change? The result of this test will be the probability of satisfaction or violation of the specified property  $\phi$  [15]. The toolbox support-

engine used for the hypothesis testing relies on the results coming from the statistics like sequential hypothesis testing or Monte Carlo simulation. Let us illustrate how one of the algorithms e.g the Monte Carlo algorithm will estimate the probability  $\gamma$  of satisfying property  $\phi$  [16]. First the user will specify the number of random simulations  $\rho_1, \rho_2 \dots \rho_{N-1}, \rho_N$ , and then probability  $\gamma$  will be estimated as:

$$\tilde{\gamma} = \frac{1}{N} \sum_{i=1}^N \mathbf{1}(\rho_i \models \phi) \quad (8)$$

where  $\mathbf{1}$  is an indicator function that will return 1 if the property  $\phi$  is satisfied for simulation run  $\rho_i$ , otherwise it will return 0. The simulation will stop either when the simulation number  $N$  or a state violating property  $\phi$  is reached. The iteration number  $N$  can be determined by Chernoff's bound [17] to obtain a confidence interval. The bound will determine the required number of simulations to be performed so that a confidence  $\delta$  with precision  $\epsilon$  entered by the user are obtained for the estimated probability.

As mentioned in the introduction, the idea behind this paper is to use the UPPAAL SMC toolbox to create a model of the MPC controller for a 2-level VSC in order to check the algorithm performance during transient load changes and parameter uncertainties. Differential equations presented in the system model (4) specify the evolving rates of clocks i.e system voltage and current. The controller has a finite structure, there are eight possible converter output voltage vectors and the one selected is the product of the cost minimization function (5). Build model can now be used to make performance analysis for different FCS-MPC algorithms just by changing the cost function. In order to check how the secondary objective in the cost function affects the performance of the model, two  $\lambda_{sw}$  values were used for result comparison. Model parameters were adjusted to fit the MATLAB/Simulink model.

### IV. EVALUATION AND COMPARISON

Simulation results obtained from the MATLAB/Simulink model were used as a benchmark data to check the behavior of the model designed in UPPAAL SMC. The implemented MPC algorithm in Simulink shows good voltage reference tracking performance for linear load as it can be observed in Fig.2. The algorithm was also tested on an experimental converter set-up as displayed in Fig. 4 using the MicroLabBox with DS1202 PowerPC DualCore 2 GHz processor board and DS1302 I/O board from dSpace. Set-up parameters: DC supply voltage  $V_{DC} = 300$  V, output filter values  $L = 2.4$  mH,  $R_L = 50$  m $\Omega$  and  $C = 25$   $\mu$ F, control algorithm time sample  $T_s = 25$   $\mu$ s, linear load  $R_{load} = 60$   $\Omega$  and capacitor voltage reference  $V_{cref} = 100$  V. Calculation time of the control algorithm is approximately 15  $\mu$ s, and to compensate this delay the predictions are calculated one step further ahead and applied at the beginning of the next time sampling interval. Fig. 5 and Fig. 6 show the measured capacitor line to line voltages for  $\lambda_{sw} = 0$  and  $\lambda_{sw} = 0.3$ . It can be observed how higher weighting factor for secondary objective resulted with increased capacitor voltage ripple.

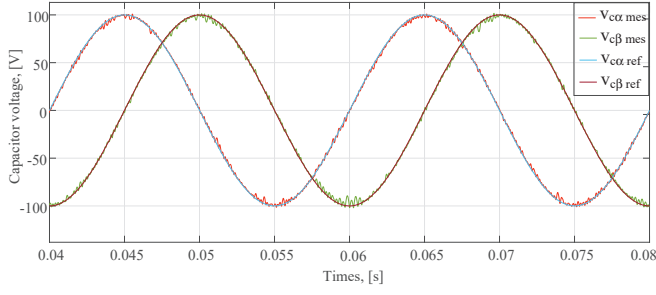

Fig. 3. Simulated capacitor voltage in stationary  $\alpha\beta$  frame using the Simulink model of the VSC

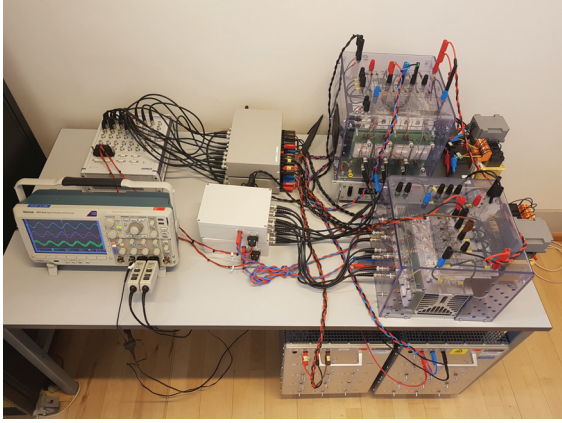

Fig. 4. Experimental set-up for verification of the FSC-MPC algorithm on a VSC

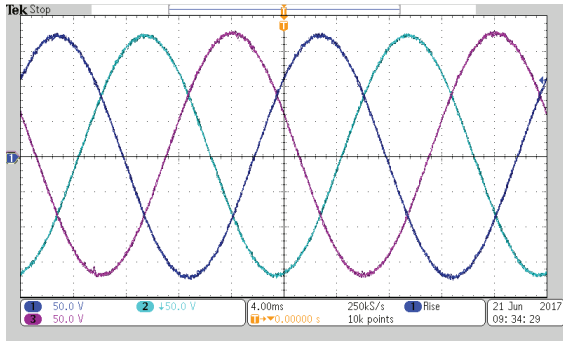

Fig. 5. Capacitor voltage measurements in experimental set-up using  $\lambda_{sw} = 0$  for VSC

Using the UPPAAL SMC verifier system currents and voltages can also be presented graphically as shown in Fig. 7. for linear load and cost function (5). By comparing the simulated capacitor voltage to the controller reference, the tracking ability of the algorithm was again proved to be satisfying, meaning the modeling in UPPAAL was correct, hence the model can be used for analytical performance validation during the transient load. Algorithm performance was assessed through two queries for the time interval of 40 ms:

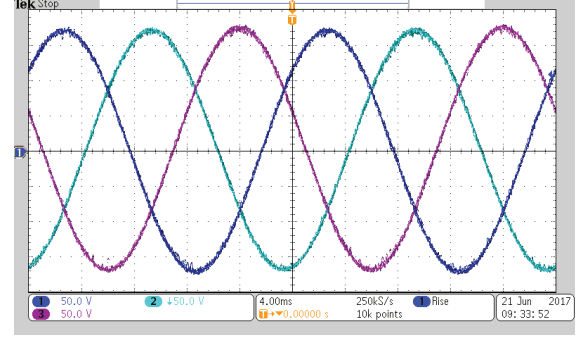

Fig. 6. Capacitor voltage measurements in experimental set-up using  $\lambda_{sw} = 0.3$  for VSC

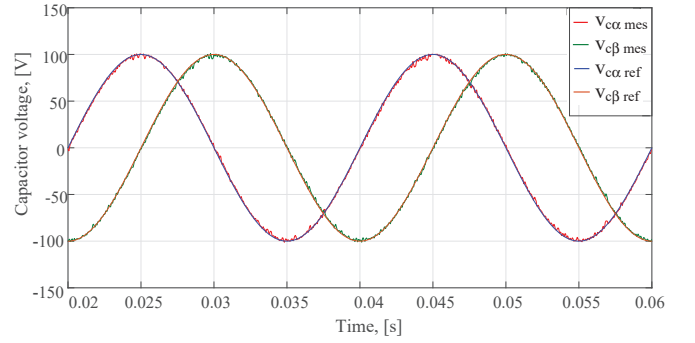

Fig. 7. Reference voltage and measured capacitor voltage in stationary  $\alpha\beta$  frame in the UPPAAL model of the VSC

$$diff = (v_{c\alpha}^* - v_{c\alpha}^m)^2 + (v_{c\beta}^* - v_{c\beta}^m)^2 \quad (9)$$

where  $v_{\alpha}^*$  and  $v_{\beta}^*$  represent the real and imaginary parts of reference voltage vector  $v^*(k)$ ,  $v_{\alpha}^m$  and  $v_{\beta}^m$  are the values of measured capacitor voltage  $v_c^m(k) = v_{c\alpha}^m + jv_{c\beta}^m$  and the second query was the simple moving average value (SMA) of the difference calculated on  $n = 10$  sample subsets.

$$SMA = SMA_{prev} + \frac{diff_M}{n} - \frac{diff_M - n}{n} \quad (10)$$

As it can be seen from the queries focus of the performance evaluation is on reference tracking ability, i.e. the difference between reference and output values is calculated. The load is changing stochastically during the time interval in UPPAAL simulations so that through several runs all possible transients can be evaluated in the queries. An example of the load current waveform during one simulation run is shown in Fig. 8. Simulation for every query is finished when the number of simulations needed for calculated probability confidence level  $\delta = 0.95$  is achieved or a state violating the property is reached. Some of the tested probabilities with corresponding uncertainty of  $\epsilon = 0.05$  for transient load with parameter uncertainty are shown in Table II. This parameter example uncertainty is introduced into the model as a false estimation of the system inductance.

The queries were tested for  $\lambda_{sw} = 0$  with the capacitor voltage as primary objective and  $\lambda_{sw} = 0.3$  with switching



TABLE II  
QUERY PROBABILITY RESULTS OBTAINED FROM UPPAAL SMC TOOLBOX VERIFIER

Query	Parameter uncertainty	Probability ( $\lambda_{sw} = 0$ )	Probability ( $\lambda_{sw} = 0.3$ )	Number of runs
$diff < 8\%$	0	0.699 - 0.799	0 - 0.097	326/36
$diff < 10\%$	0	0.902 - 1	0.107 - 0.206	36/217
$diff < 12\%$	0	0.902 - 1	0.620 - 0.720	36/357
$diff < 15\%$	0	0.902 - 1	0.902 - 1	36/36
$diff < 12\%$	30%	0.596 - 0.696	0 - 0.097	369/36
$diff < 15\%$	30%	0.902 - 1	0.667 - 0.767	36/328
$SMA < 8\%$	0	0.774 - 0.874	0 - 0.097	238/36
$SMA < 10\%$	0	0.902 - 1	0 - 0.097	36/36
$SMA < 12\%$	0	0.902 - 1	0.632 - 0.732	36/351
$SMA < 10\%$	30%	0.222 - 0.322	0 - 0.097	322/36
$SMA < 12\%$	30%	0.654 - 0.754	0.013 - 0.11	337/88
$SMA < 15\%$	30%	0.902 - 1	0.641 - 0.741	36/345

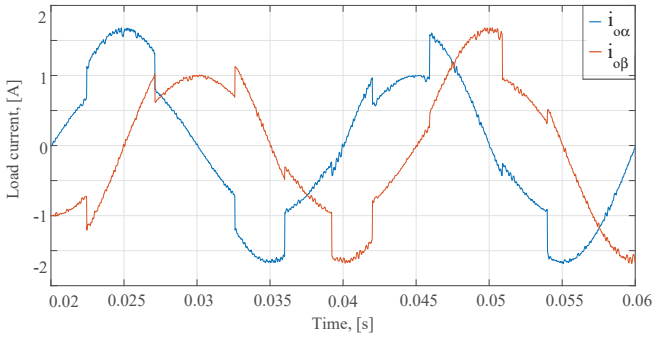

Fig. 8. Load current under transient load change in the UPPAAL model of the VSC

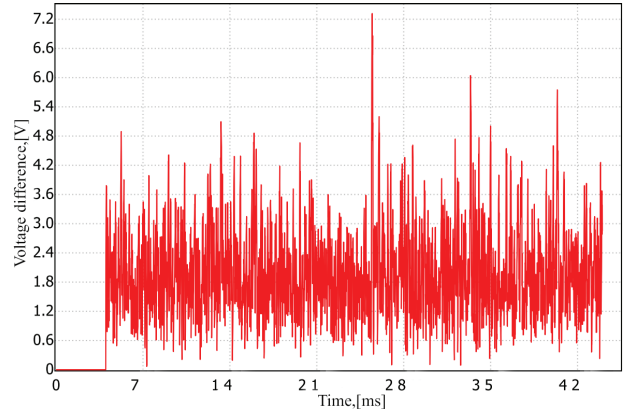

Fig. 9. Difference between the reference and capacitor voltage in UPPAAL model during one simulation run under transient load change

frequency minimization applied as the secondary objective. The last column in the Table II represents the number of runs that the UPPAAL SMC toolbox performed during query processing. If the query probability is close to 0 or 1, the number of runs necessary for assessment is low. The second query  $diff < 10\%$  for  $\lambda_{sw} = 0$  will be presented in detail. Number of simulations needed to provide the level of uncertainty  $\epsilon = 0.05$  was 36, during each simulation run the load value changed stochastically which results in current like shown in Fig. 8, difference and SMA values were calculated for each run. An example of the calculated values for one run is presented in Fig. 9 and Fig. 10. The first transient ( $t = 0 - 4$  ms) which occurs because of the system's initial states were set to 0 was omitted from the calculation. It can be observed that the difference is staying below 10% threshold, meaning that the system voltage is always tracking the reference even under transient load change and there are no significant degenerations in the reference tracking.

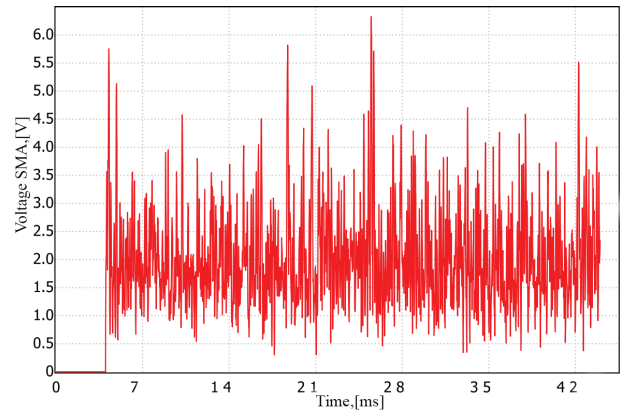

Fig. 10. SMA of the reference and capacitor voltage in UPPAAL model during one simulation run under transient load change

As presented in the Table II the system with  $\lambda_{sw} = 0.3$  showed higher probability to produce larger difference value during the transients. The lowest difference guaranteed to have

a probability close to 1 was 10% for first function, which means that during the load transients at no time the difference

between the reference (100 V) and system voltage will be larger than 10 V. Both  $\lambda_{sw}$  values produced a probability close to 1 for differences  $< 15\%$ . With the introduction of the parameter uncertainty it can be seen that the the probability of exceeding the difference threshold for system with  $\lambda_{sw} = 0.3$  was 30% lower. It can be deduced that the parameter uncertainty has a larger impact on this type of cost function. The obtained results are also useful for weighting factor selection as the performance degradation/improvement of each secondary term in the cost function can easily be evaluated. If the calculated SMA value of the system needs for instance to stay during transients below 12% a lower  $\lambda_{sw}$  value should be selected for (5).

## V. CONCLUSION

In this paper the performance evaluation of the FSC-MPC algorithm for 2-level VSC was done using UPPAAL SMC toolbox. A conversion from the Simulink system model to UPPAAL model was simple and the process of performance evaluation was uncomplicated and fast. Created model in the toolbox proved that the reference tracking error of the designed control algorithm will stay below 15% with the corresponding probability certainty of 0.95 even with introduction of the parameter uncertainty under transient load. Cost function with weighting factor  $\lambda_{sw} = 0.3$  presented two times higher probability that the difference will be higher than 12% because the applied switching state was chosen not only to minimize reference error but also to choose the state with lower number of commutations. Overall, during the performance evaluation no significant degradation of reference tracking was found during transients nor under model parameter uncertainty. The presented MPC performance validation approach showed many possibilities for future work with focus on analytical performance evaluation of other MPC algorithms and converter topologies plus more complex load models. Further research will show if the SMC is the new powerful tool to solve the problem of performance and stability evaluation for MPC algorithms in different types of power converters.

## REFERENCES

- [1] S. Kouro, M. A. Perez, J. Rodriguez, A. M. Llor, and H. A. Young, "Model predictive control: MPC's role in the evolution of power electronics," *IEEE Industrial Electronics Magazine*, vol. 9, no. 4, pp. 8–21, Dec 2015.
- [2] S. Vazquez, J. Rodriguez, M. Rivera, L. G. Franquelo, and M. Norambuena, "Model predictive control for power converters and drives: Advances and trends," *IEEE Transactions on Industrial Electronics*, vol. 64, no. 2, pp. 935–947, Feb 2017.
- [3] V. Yaramasu and B. Wu, *Model Predictive Control of Wind Energy Conversion Systems*, ser. IEEE Press Series on Power Engineering. Wiley, 2016.
- [4] S. Vazquez, J. I. Leon, L. G. Franquelo, J. Rodriguez, H. A. Young, A. Marquez, and P. Zanchetta, "Model predictive control: A review of its applications in power electronics," *IEEE Industrial Electronics Magazine*, vol. 8, no. 1, pp. 16–31, March 2014.
- [5] R. P. Aguilera and D. E. Quevedo, "Predictive control of power converters: Designs with guaranteed performance," *IEEE Transactions on Industrial Informatics*, vol. 11, no. 1, pp. 53–63, Feb 2015.
- [6] A. David, K. G. Larsen, A. Legay, and M. Mikućionis, "Schedulability of herschel revisited using statistical model checking," *Int. J. Softw. Tools Technol. Transf.*, vol. 17, no. 2, pp. 187–199, Apr. 2015.

- [7] A. Boudjadar, A. David, J. Kim, K. Larsen, M. Mikućionis, U. Nyman, and A. Skou, "Statistical and exact schedulability analysis of hierarchical scheduling systems," *Science of Computer Programming*, vol. 127, pp. 103–130, 5 2016.
- [8] K. G. Larsen, M. Mikućionis, M. Muñiz, J. Srba, and J. H. Taankvist, *Online and Compositional Learning of Controllers with Application to Floor Heating*. Springer Berlin Heidelberg, 2016, pp. 244–259.
- [9] A. David, K. G. Larsen, A. Legay, M. Mikućionis, and D. B. Poulsen, "Uppaal SMC tutorial," *Int. J. Softw. Tools Technol. Transf.*, vol. 17, no. 4, pp. 397–415, Aug. 2015.
- [10] Statistical model-checker - new SMC extension of UPPAAL. [Online]. Available: <http://people.cs.aau.dk/~adavid/smc/>
- [11] P. Cortes, G. Ortiz, J. I. Yuz, J. Rodriguez, S. Vazquez, and L. G. Franquelo, "Model predictive control of an inverter with output LC filter for UPS applications," *IEEE Transactions on Industrial Electronics*, vol. 56, no. 6, pp. 1875–1883, June 2009.
- [12] "IEC standard for uninterruptible power systems (UPS) - part 3: Method of specifying the performance and test requirements," *IEC 62040-3:2011*, no. 2, pp. 1–214, March 2011.
- [13] J. Rodriguez and P. Cortes, *Delay Compensation*. John Wiley and Sons, Ltd, 2012, pp. 177–189.
- [14] P. Bulychchev, A. David, K. Guldstrand Larsen, A. Legay, M. Mikućionis, and D. Bøgsted Poulsen, *Checking and Distributing Statistical Model Checking*. Berlin, Heidelberg: Springer Berlin Heidelberg, 2012, pp. 449–463.
- [15] A. Legay, B. Delahaye, and S. Bensalem, *Statistical Model Checking: An Overview*. Berlin, Heidelberg: Springer Berlin Heidelberg, 2010, pp. 122–135.
- [16] Q. Cappart, C. Limbre, P. Schaus, J. Quilbeuf, L. M. Traounez, and A. Legay, "Verification of interlocking systems using statistical model checking," in *2017 IEEE 18th International Symposium on High Assurance Systems Engineering (HASE)*, Jan 2017, pp. 61–68.
- [17] H. Chernoff, "A measure of asymptotic efficiency for tests of a hypothesis based on the sum of observations," *Ann. Math. Statist.*, vol. 23, no. 4, pp. 493–507, 12 1952.