



Durham E-Theses

Microreactors and other technologies for direct fluorination

Holling, Darren

How to cite:

Holling, Darren (2002) *Microreactors and other technologies for direct fluorination*, Durham theses, Durham University. Available at Durham E-Theses Online: <http://etheses.dur.ac.uk/3977/>

Use policy

The full-text may be used and/or reproduced, and given to third parties in any format or medium, without prior permission or charge, for personal research or study, educational, or not-for-profit purposes provided that:

- a full bibliographic reference is made to the original source
- a [link](#) is made to the metadata record in Durham E-Theses
- the full-text is not changed in any way

The full-text must not be sold in any format or medium without the formal permission of the copyright holders.

Please consult the [full Durham E-Theses policy](#) for further details.

University of Durham

A Thesis Entitled

**Microreactors and Other Technologies for Direct
Fluorination**

The copyright of this thesis rests with the author.
No quotation from it should be published without
his prior written consent and information derived
from it should be acknowledged.

Submitted by

Darren Holling M.Sci. (Hons) Dunelm

(Graduate Society)

Department of Chemistry

A Candidate for the Degree of Doctor of Philosophy
2002



18 DEC 2002

I

Acknowledgements

I would like to thank Dr. Graham Sandford and Professor Richard D. Chambers for all of their help and support throughout this project. I would also like to give thanks to Dr. John Hutchinson for helpful discussions and also to EPSRC who provided funding.

I also thank all of the other members of the research group past and present, namely: Dr. Ali Khali, Dr. Tony Rees, Dr. Ian Wilson, Dr. Julian A. Cooper, Dr. Philip Hoskin, Dr. Mandy Parsons, Dr. Hadjar Benmansour, Dr. Christel Olivaries, Dr. Paul Richmond, Dr. Jamal Bousbaa, Miss Elodie Copin, Miss Emmanuelle Thomas, Mr Christopher Murray, Mr Takashi Nakano, and Miss Jelena Trmčić. I also thank Mr Jim Hodgson and Mr Neil Holmes for advice and engineering assistance.

This research would not have been possible without the help and enthusiasm of the department technical staff, namely: Dr. Alan Kenwright, Mr Ian McKeag and Mrs Catherine Heffernan (NMR); Dr. Mike Jones and Miss Lara Turner (Mass Spectrometry); Mrs Jaraka Dostal (Elemental analysis); Dr. H. Puschmann, Dr. D. S. Yufit and Dr. A. S. Batsanov (X-ray crystallography); Mr Andrew Yates (Electron Microscopy); Dr. Mark Garner, Mr Colin Greenhalgh, Mr Alan Harland (Computing); Dr. Tony Royston (Computing and German Translations); Mr Lenny Lauchlan (Chromatography); Mr. Ray Hart, Mr. Gordon Haswell, Mr Malcolm Richardson and Mr. Peter Coyne (Glassblowing); Mr Kelvin Appleby, Mr Barry Barker, Mr George Rowe (Electrical Technicians); Mr. David Hunter (High Pressure Operations); Mr. Jimmy Lincoln, Mrs Elizabeth Wood, Mr Toni Baxter, and Mr Joe Peel (Stores) and Dr. Euan Ross and Dr. Hilary Hull (Administration).

I also thank all the other people who worked and studied in the chemistry department who have not been mentioned.

I also would like to thank Miss Olivia Koentjoro for editorial discussion and for putting up with my constant complaining and Yorkshireness.

Memorandum

The work present within this thesis was carried out at the University of Durham between October 1999 and August 2002. This thesis is the work of the author, except where acknowledged by reference and has not been submitted for any other degree. The copyright of this thesis lies solely with the author and no quotation from it should be published without prior written consent and information derived from it should be acknowledged.

Part of this work has been the subject of the following:

- R.D. Chambers, D. Holling, R.C.H. Spink, G. Sandford; Lab on a Chip, 2001 1 132
- R.D. Chambers, D. Holling, J.A.K. Howard, H. Puschmann, G. Sandford; J. Fluorine Chem. (in press)
- R.D. Chambers, D. Holling, G. Sandford; United Kingdom Patent Application: GB 01210809.0, Filing date 11 May 2002

and has been presented at:

- 13th European Symposium on Fluorine Chemistry, Bordeaux, France, 2001
- Avecia Poster Session, University of Durham, December 2001
- Royal Society of Chemistry North-East Perkin Division Meeting, University of York, April 2002
- Crystal Faraday Partnership Workshop, Daresbury, May 2002
- 8th RSC-SCI Joint Meeting on Heterocyclic Chemistry, Edinburgh, May 2002
- Durham University Chemistry Department Final Year Postgraduate Symposium, July 2002
- North-East New Synthetic Methods Symposium, University of Sunderland, July 2002

Nomenclature and Abbreviations

Note that fluorine in the centre of a ring denotes all of the hydrogen atoms have been replaced by fluorine.

NMR	Nuclear Magnetic Resonance
GC-MS	Gas Chromatography-Mass Spectrometry
IR	Infrared
UV	Ultra Violet Light

Numbering of System

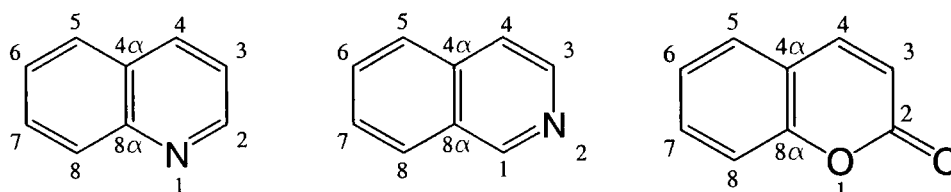

Statement of Copyright

No part of this thesis may be reproduced by any means, nor transmitted, nor translated into any machine language without the written permission of the author.

Abstract

Quinoline/ 2H-chromen-2-one and derivatives thereof, have been found to undergo electrophilic substitution by elemental fluorine in concentrated sulfuric acid as reaction medium. This work has enabled a series of fluorinated derivatives to be prepared.

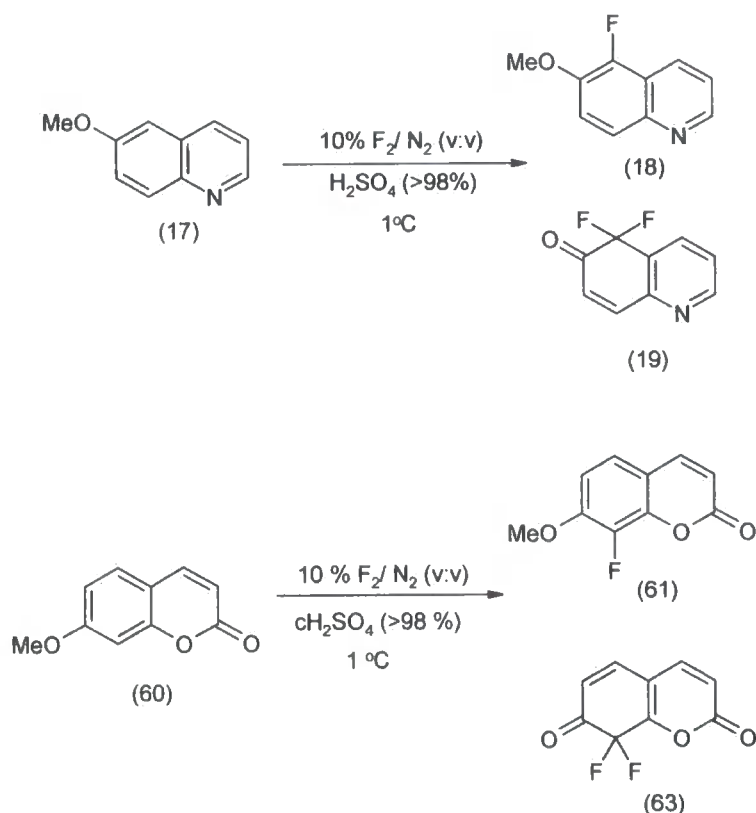

Furthermore, several direct fluorination microreactors have been designed and subsequently evaluated regarding scale-out, and thus the fluorination of a number of organic compounds was achieved using microreactor technology.

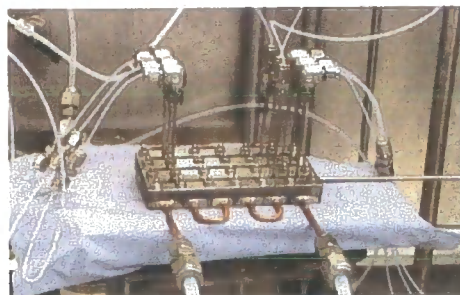

Contents

Page Number

Chapter 1.0: General Introduction-Elemental Fluorine

<u>1.1</u>	Fluorine in Nature	1
<u>1.2</u>	Properties of Carbon-Fluorine Bonds	4
<u>1.3</u>	Physical Properties of Elemental Fluorine	5
<u>1.4</u>	Reactivity of Elemental Fluorine	6
<u>1.5</u>	Applications of Fluorinated Compounds	7
<u>1.6</u>	The Isolation of Fluorine: A Brief History	8
<u>1.7</u>	Production of Fluorine	9
<u>1.7.1</u>	Generation of Hydrogen Fluoride	9
<u>1.7.2</u>	Production of Fluorine by Electrochemical Methods	9
<u>1.7.3</u>	Production of Fluorine by Chemical and Other Methods	10
<u>1.8</u>	Electrophilic Fluorination of Organic Compounds	11
<u>1.8.1</u>	Radical Fluorination of Organic Compounds	11
<u>1.8.2</u>	Electrophilic Fluorination of Organic Compounds	13
<u>1.9</u>	Direct Fluorination Using Elemental Fluorine (1996-Present)	15
<u>1.9.1</u>	Direct Fluorination of Aromatic Compounds	15
<u>1.9.2</u>	Direct Fluorination of Heteroaromatic Compounds	21
<u>1.9.3</u>	Direct Fluorination of Hydrocarbons	22
<u>1.9.4</u>	Direct Fluorination of Carbonyl Compounds	24
<u>1.9.5</u>	Direct Fluorination of Alkene Compounds	27
<u>1.9.6</u>	Fluorination at Heteroatoms	29
<u>1.9.6.1</u>	Fluorination at Nitrogen Centres	29
<u>1.9.6.2</u>	Fluorination at Oxygen Centres	30
<u>1.9.6.3</u>	Fluorination at Sulfur Centres	31
<u>1.10</u>	Radical Fluorination of Organic Compounds	33
<u>1.10.1</u>	Partially Fluorinated Compounds	33
<u>1.10.2</u>	Perfluorinated Compounds	34
<u>1.11</u>	Direct Fluorination Technology	37
<u>1.11.1</u>	Liquid-Phase Fluorination Technology	37
<u>1.11.2</u>	Vapour-Phase Fluorination Technology	38
<u>1.11.3</u>	LaMar Fluorination Technology	39

<u>1.11.4</u>	Aerosol Fluorination Technology	39
<u>1.5</u>	Chapter 1.0 Summary	40

Chapter 2.0: The Direct Fluorination of N-Heterocycles

<u>2.1</u>	Introduction	41
<u>2.1.1</u>	General Introduction	41
<u>2.1.2</u>	Electrophilic Attack on Quinoline/ Isoquinoline	41
<u>2.2</u>	Methods for Preparing Fluorinated Quinolines/ Isoquinolines	45
<u>2.2.1</u>	Electrophilic Fluorination	45
<u>2.2.2</u>	Balz-Schiemann Reaction	46
<u>2.2.3</u>	Halex Reaction	47
<u>2.2.4</u>	Skraup Synthesis and Related Methodology	47
<u>2.2.4.1</u>	Skraup Quinoline Synthesis	47
<u>2.2.4.2</u>	Doebner-von Miller Quinoline Synthesis	48
<u>2.2.5</u>	Previous Work Involving Elemental Fluorine	48
<u>2.3</u>	Direct Fluorination of N-Heteroaromatics	51
<u>2.3.1</u>	Quinoline (1)	51
<u>2.3.1.1</u>	Solvent Survey	51
<u>2.3.1.2</u>	Solvent Survey Conclusion	54
<u>2.3.1.3</u>	Quinoline (1) in Sulfuric Acid	54
<u>2.3.1.4</u>	Concluding remarks	57
<u>2.3.2</u>	Heterocyclic and/or Carbocyclic Ring Substituted Quinolines	57
<u>2.3.2.1</u>	2-Chloroquinoline (7)	57
<u>2.3.2.2</u>	4-Methylquinoline (12)	58
<u>2.3.2.3</u>	Concluding Remarks Concerning Heterocyclic Ring Substituted Quinolines	59
<u>2.3.3</u>	Carbocyclic Ring and Carbocyclic-Heterocyclic ring Substituted Quinolines	60
<u>2.3.3.1</u>	6-Methoxyquinoline (17)	60
<u>2.3.3.2</u>	2-Chloro-6-methoxyquinoline-3-carbaldehyde (20)	62
<u>2.3.3.3</u>	6-Methoxy-8-nitroquinoline (23)	65

<u>2.3.3.4</u>	6-Chloroquinoline (26)	68
<u>2.3.3.5</u>	6-Methylquinoline (29)	69
<u>2.3.3.6</u>	6-Nitroquinoline (33)	71
<u>2.3.3.7</u>	4,7-Dichloroquinoline (35)	74
<u>2.3.3.8</u>	2,7-Dimethylquinoline (38)	76
<u>2.3.3.9</u>	8-Methylquinoline (41)	78
<u>2.3.3.10</u>	Concluding Remarks	83
<u>2.3.4</u>	Isoquinoline (44)	83
<u>2.3.4.1</u>	Solvent Survey	83
<u>2.3.4.2</u>	Solvent Survey Conclusion	86
<u>2.3.4.3</u>	Isoquinoline (44) in Sulfuric Acid	86
<u>2.3.4.4</u>	Concluding Remarks	87
<u>2.4</u>	Chapter 2.0 Summary	87

Chapter 3.0: The Direct Fluorination of O-Heterocycles

<u>3.1</u>	Introduction	88
<u>3.1.1</u>	General Introduction	88
<u>3.1.2</u>	Electrophilic halogenation of 2H-chromen-2-one	88
<u>3.2</u>	Methods for Preparing Fluorinated 2H-Chromen-2-ones	92
<u>3.2.1</u>	Electrophilic Fluorination	92
<u>3.2.2</u>	Balz-Schiemann Reaction	93
<u>3.2.3</u>	Halex Reaction	93
<u>3.2.4</u>	Cyclisation Methodology	93
<u>3.2.4.1</u>	Pechmann Synthesis	94
<u>3.2.4.2</u>	Knoevenagel Synthesis	94
<u>3.2.5</u>	Previous Work Involving Elemental Fluorine	94
<u>3.3</u>	Direct Fluorination of O-Heteroaromatics	95
<u>3.3.1</u>	2H-Chromen-2-one (49)	95
<u>3.3.1.1</u>	Solvent Survey	95
<u>3.3.1.2</u>	Solvent Survey Conclusion	98
<u>3.3.1.3</u>	2H-Chromen-2-one (49) in Sulfuric Acid	98

<u>3.3.1.4</u>	Concluding Remarks	100
<u>3.3.2</u>	Carbocyclic and Carbocyclic/ Heterocyclic Ring	
	Substituted 2H-Chromen-2-ones	100
<u>3.3.2.1</u>	6-Methyl-2H-chromen-2-one	100
<u>3.3.2.2</u>	7-Methoxy-2H-chromen-2-one	103
<u>3.3.2.3</u>	7-Ethoxy-4-methyl-2H-chromen-2-one	106
<u>3.4</u>	Chapter 3.0 Summary	109

Chapter 4.0: General Introduction-Microreactor Technology

<u>4.1</u>	Introduction	110
<u>4.1.1</u>	Conventional Chemical Manufacturing	110
<u>4.1.2</u>	Process Intensification	112
<u>4.2</u>	Microreactor Definition	112
<u>4.2.1</u>	Advantages of Microreactors	112
<u>4.2.2.1</u>	Physical Benefits	113
<u>4.2.2.2</u>	Scale-Out	114
<u>4.2.2.3</u>	Disadvantages of Microreactors	116
<u>4.3</u>	Types of Microreactor	117
<u>4.3.1</u>	Gas-Liquid Phase Flow in Microchannels	118
<u>4.3.1.1</u>	Vertical Gas-Liquid Phase Flows	118
<u>4.3.1.2</u>	Horizontal Gas-Liquid Flow	120
<u>4.4</u>	Microreactor Fabrication Techniques	121
<u>4.4.1</u>	Computer Aided Design (CAD)	122
<u>4.4.2</u>	Conventional Machining Techniques	122
<u>4.4.3</u>	Electric Discharge Machining (EDM)	124
<u>4.4.4</u>	Etching	126
<u>4.4.5</u>	Laser Cutting	127
<u>4.5</u>	Elemental Halogenation Microreactors - A Review	127
<u>4.5.1</u>	Bromination Microreactor	128
<u>4.5.2</u>	Chlorination Microreactor	128
<u>4.5.3</u>	Fluorination Microreactor	130

<u>4.6</u>	Chapter 4.0 Summary	135
------------	---------------------	-----

Chapter 5.0: Direct Fluorination Microreactor Design

<u>5.1</u>	Introduction	137
<u>5.2</u>	Design of the Three-Channel Microreactor (V-19)	137
<u>5.3</u>	Design of the Twelve-Channel Microreactor (V-20)	146
<u>5.4</u>	Design Of the Multi-Channel Microreactor (V-21)	152
<u>5.5</u>	Chapter 5.0 Summary	163

Chapter 6.0: Direct Fluorination of Organic Compounds Using Microreactor Technology

<u>6.1</u>	Introduction	164
<u>6.2</u>	Single Channel Microreactor	165
<u>6.3</u>	V-19 Microreactor (Three Channel Microreactor)	166
<u>6.3.1</u>	1,3-Dicarbonyl Compounds	166
<u>6.3.2</u>	Aromatic Compounds	169
<u>6.3.2.1</u>	1-Methyl-4-nitrobenzene (87)	169
<u>6.3.2.2</u>	1-Methyl-2,4-dinitrobenzene (89)	171
<u>6.3.3</u>	3-Nitrophenyl Disulfide (91)	172
<u>6.3.4</u>	V-19 Microreactor Conclusion	175
<u>6.4</u>	V-21 Microreactor (Multi-Channel Microreactor)	176
<u>6.4.1</u>	Three Channel Template Plate (V-21-3)	176
<u>6.4.2</u>	Nine Channel Template Plate (V-21-9)	178
<u>6.4.3</u>	V-21 Microreactor Conclusion	180
<u>6.5</u>	Chapter 6 Summary	181

Chapter 7.0: Experimental to Chapter 2.0

<u>7.1</u>	Instrumentation	182
<u>7.2</u>	The Use of Elemental Fluorine in the Laboratory	184
<u>7.3</u>	General Procedure	192
<u>7.3.1</u>	Direct Fluorination of quinoline (1)	192

<u>7.3.2</u>	Direct Fluorination of 2-Chloroquinoline (7)	195
<u>7.3.3</u>	Direct Fluorination of 4-Methylquinoline (12)	195
<u>7.3.4</u>	Direct Fluorination of 6-Methoxyquinoline (17)	196
<u>7.3.5</u>	Direct Fluorination of 2-Chloro-6-methoxyquinoline- 3-carbaldehyde (20)	197
<u>7.3.6</u>	Direct Fluorination of 6-Methoxy-8-nitroquinoline (23)	199
<u>7.3.7</u>	Direct Fluorination of 6-Chloroquinoline (26)	200
<u>7.3.8</u>	Direct Fluorination of 6-Methylquinoline (29)	200
<u>7.3.9</u>	Direct Fluorination of 6-Nitroquinoline (33)	201
<u>7.3.10</u>	Direct Fluorination of 4,7-Dichloroquinoline (35)	203
<u>7.3.11</u>	Direct Fluorination of 2,7-Dimethylquinoline (38)	203
<u>7.3.12</u>	Direct Fluorination of 8-Methylquinoline (41)	204
<u>7.3.13</u>	Direct Fluorination of Isoquinoline (44)	206

Chapter 8.0: Experimental Section to Chapter 3.0

<u>8.1</u>	General Procedure	208
<u>8.1.1</u>	Direct fluorination of 2H-chromen-2-one (49)	208
<u>8.1.2</u>	Direct fluorination of 6-methyl-2H-chromen-2-one (57)	210
<u>8.1.3</u>	Direct fluorination of 7-methoxy-2H-chromen-2-one (60)	212
<u>8.1.4</u>	Direct fluorination of 7-ethoxy-4-methyl-2H- chromen-2-one (65)	214

Chapter 9.0: Experimental Section to Chapter 5.0

<u>9.1</u>	Fabrication of the Microreactors	217
<u>9.1.1</u>	Fabrication of the Triple-Channel Microreactor (V-19) and Accompanying Apparatus	217
<u>9.1.2</u>	Fabrication of the Twelve-Channel Microreactor (V-20)	224
<u>9.1.3</u>	Fabrication of the Multi-Channel Microreactor (V-21)	227

Chapter 10.0: Experimental Section to Chapter 6.0

<u>10.1</u>	Direct Fluorination Using Microreactor Technology	235
<u>10.1.1</u>	General Procedure	235

<u>10.2</u>	Single Channel Microreactor General Procedure	235
<u>10.2.1</u>	Direct fluorination of ethyl 3-oxobutanoate (70)	235
<u>10.2.2</u>	Direct fluorination of ethyl 2-methyl-3-oxobutanoate (74)	236
<u>10.2.3</u>	Direct fluorination of 3-acetyl-3,4,5-trihydrofuran-2-one (77)	237
<u>10.2.4</u>	Direct fluorination of 2-acetylcyclohexan-1-one (80)	237
<u>10.2.4</u>	Direct fluorination of ethyl 2-oxocyclohexane carboxylate (83)	238
<u>10.3</u>	Triple Channel Microreactor General Procedure	238
<u>10.3.1</u>	1,3-Dicarbonyl Compounds	239
<u>10.3.1.1</u>	Direct fluorination of ethyl 3-oxobutanoate (70)	239
<u>10.3.1.2</u>	Direct fluorination of ethyl 2-methyl-3-oxobutanoate (74)	239
<u>10.3.1.3</u>	Direct fluorination of 2-acetylcyclohexan-1-one (80)	240
<u>10.3.1.4</u>	Direct fluorination of ethyl 2-chloro-3-oxobutanoate (85)	240
<u>10.3.2</u>	Aromatic Compounds	241
<u>10.3.2.1</u>	1-Methyl-4-nitrobenzene General Procedure	241
<u>10.3.2.2</u>	1-Methyl-2,4-dinitrobenzene General Procedure	242
<u>10.3.2.3</u>	Direct fluorination of 3-nitrophenyl disulfide (91)	243
<u>10.4</u>	V-21-3 General Procedure	245
<u>10.4.1</u>	Direct fluorination of ethyl 3-oxobutanoate (70)	246
<u>10.4.2</u>	Direct fluorination of 3-acetyl-3,4,5-trihydrofuran-2-one (77)	247
<u>10.5</u>	General Procedure (V-21-9)	247
<u>10.5.1</u>	Direct fluorination of ethyl 3-oxobutanoate (70)	247
	Appendix	249
	References	249

Accompanying Compact Disc

Full infra red spectra, mass spectrometry spectra and X-ray crystal structure data, where relevant, and further microreactor pictures and diagrams are supplied on the CD.

Chapter 1.0: General Introduction-Elemental Fluorine

1.1 Fluorine in Nature

Fluorinated organic natural products are rarely found in nature, indeed there are less than twenty biological examples currently known.¹⁻⁴ Some of these natural fluorine containing compounds can be seen in figure 1.1.

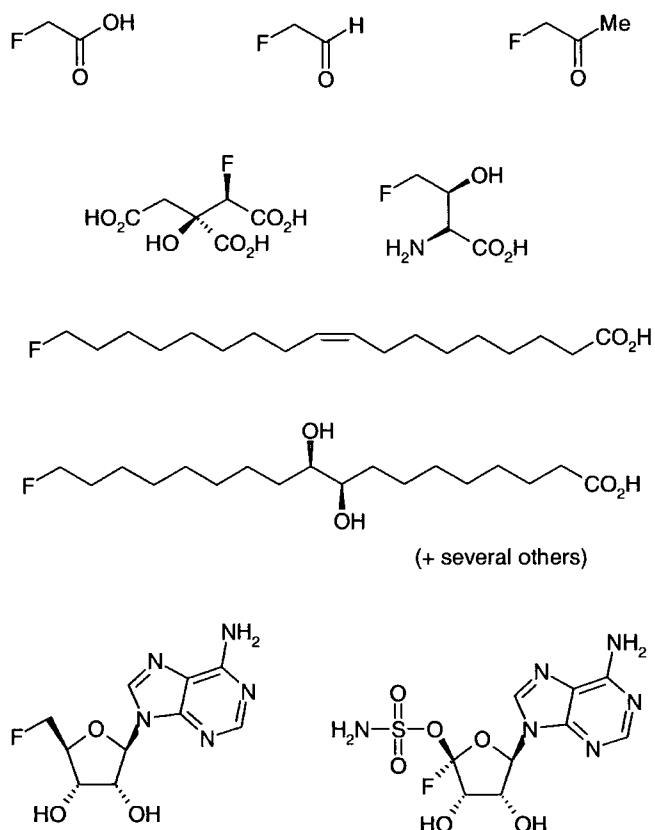

Fig 1.1

A further ten fluoro-organic compounds have been identified from geological sources, one of these being volcanoes; they include amongst them CHCl_2F , CHClF_2 , CCl_3F , and even CF_4 . On the other hand, natural products containing chlorine, bromine, and iodine, are more numerous in nature. This appears at first glance to be somewhat surprising considering that fluorine has been estimated as the thirteenth most abundant element in the earth's crust. For comparison chlorine has been estimated as the 20th,



bromine the 46th and iodine the 60th.⁵ However, unlike the other halogens, most of the fluorine present is biologically unavailable.

Fluorine can also be found in various mineral deposits, and the majority of is in the form of complex inorganic compounds at low concentration. Fortunately, minerals exist from which fluorine may be extracted, the most important being fluorspar (fluorite, CaF_2). Other rare simple minerals containing fluorine are known, some examples are: villaumite (NaF), sellarite (MgF_2), yttracrite ($\text{Ca}_3\text{Ce}_2\text{Y}_2\text{F}_6$), fluorapatite $\text{Ca}_5(\text{PO}_4)_3\text{F}$, and cryolite (Na_3AlF_6).⁶

Simple inorganic compounds such as HF , AlF , MgF , and CaF have also been detected in stars and interstellar space.⁷⁻⁹ Unlike the majority of the other elements, the origin of fluorine is still debated and several pathways have been postulated (See Fig 1.2).^{10, 11} Likely nucleosynthetic routes include stellar hydrogen and helium burning areas, which are depicted in figure 1.2.¹² It is worth noting that these processes take place at extremely high temperatures, typically millions of degrees, as such atom nuclei and electrons become separated, i.e. a plasma state. As a result, hydrogen burning involves protons, and similarly helium burning involves α particles.

Hydrogen Burning Pathway

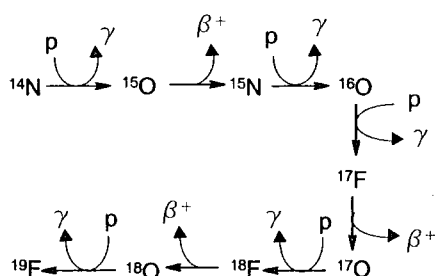

Helium Burning Pathway

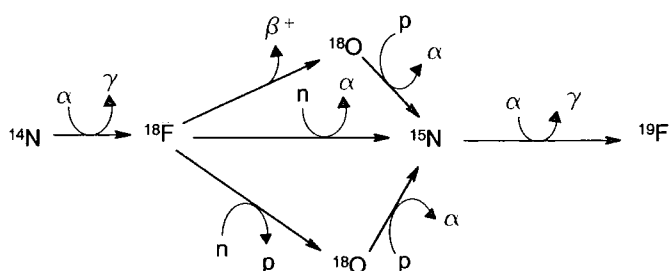

Fig 1.2: α = alpha particle, β^+ = positron, γ = gamma ray, p = proton, and n = neutron (Curly arrows indicate reaction; e.g. $^{14}\text{N}(\text{p}) \rightarrow ^{15}\text{O}(\gamma)$ means that a nitrogen-14 nuclei undergoes a nuclear reaction with a proton to give an oxygen-15 nuclei and a gamma ray.)

The natural scarcity of fluorine containing organic compounds has therefore made the area of organo-fluorine chemistry a novel branch of chemistry. In fact, the majority of all fluorochemicals are derived indirectly from fluorspar (CaF_2), the main fluoride source for the production of hydrogen fluoride. Hydrogen fluoride is then used in the preparation of many known fluorinated compounds, although, elemental fluorine is often required for the preparation of many compounds, such as perfluoro-organic compounds and transition metal fluorides.¹³

1.2 Properties of Carbon-Fluorine Bonds

The introduction of one or more fluorine atoms into an organic compound can impart unique chemical and physical properties to the compound, when compared to the unfluorinated derivative. Several properties of fluorine are listed below (See Table 1.1):

- 1) Fluorine is the most electronegative element (Pauling scale), hence the introduction of fluorine can perturb the overall electronic properties of the molecule due to the fact that carbon-fluorine bonds are more polarised than other carbon-halogen bonds.
- 2) Fluorine forms the strongest single bond to carbon (485kJmol^{-1}), often causing compounds containing fluorine, especially those containing multiple fluorine atoms to have increased thermal stability.
- 3) Fluorine has a relatively small bond length and Van der Waals radii giving it a steric size similar to that of oxygen. Steric effects arising from the introduction of a fluorine atom are unlikely to disturb the structure any more than the introduction of oxygen.
- 4) Fluorine possesses three non-bonding electron pairs, which results in weak intermolecular interactions between perfluorinated compounds.

Table 1.1: Properties of C-X bonds¹⁴⁻¹⁶

Property	F	Cl	Br	I	H	O
Electronegativity (Pauling)	4.0	3.0	2.8	2.5	2.1	3.6
C-X bond energy (kJmol^{-1})	485	327	285	213	411	358
Bond Length (\AA)	1.35	1.77	1.94	2.14	1.09	1.43
Mean van der Waals radii (\AA)	1.47	1.75	1.85	1.98	1.20	1.52

1.3 Physical Properties of Elemental Fluorine

At ambient temperature, elemental fluorine exists as a pale yellow-green gas. Further properties of fluorine, along with properties of the other halogens for comparison, are presented in table 1.2.

Table 1.2: Selected physical properties of the non radioactive halogens⁵

Property	F	Cl	Br	I
Atomic Number	9	17	35	53
Melting Point of X ₂ (°C)	-216.8	-101.0	-7.25	113.6
Boiling Point of X ₂ (°C)	-188.1	-34.0	59.5	185.2
Ionisation Energy of X· (kJmol ⁻¹)	1680.6	1255.7	1142.7	1008.7
Electron Affinity of X· (kJmol ⁻¹)	332.6	348.5	324.7	295.5
Bond Dissociation Energy of X ₂ (kJmol ⁻¹)	158.8	242.6	192.8	151.1
Bond Distance X-X (Å)	143	199	228	266

1.4 Reactivity of Elemental Fluorine

Fluorine is known to be the most reactive element, and consequently can form compounds with all elements except helium, neon, and argon. The handling of elemental fluorine would not be possible, if it was not for the fact that some metals form protective surface films of metal fluoride, which prevents further fluorination taking place. Consequently, metals/ alloys found to be suitable for the handling of fluorine, namely, copper, nickel, and alloys thereof, are pre-treated with increasing concentrations of fluorine before actual use.

The reactivity of elemental fluorine is mainly due to two facts, which are:

- 1) The F-F bond is very weak (See Table 1.2)
- 2) Fluorine forms very strong bonds with many other elements. Several fluorine bond strengths are tabulated in Table 1.3

Table 1.3: Fluorine bond strengths¹⁴

Bond Type	Bond Strength (kJmol⁻¹)
F-F	159
C-F	485
H-F	565
Si-F	565

1.5 Applications of Fluorinated Compounds

The unique properties of fluorine containing compounds (discussed in section 1.2) have led to fluorochemicals being used in a wide range of areas. They have found use in areas such as agrochemicals, pharmaceuticals, polymers, and high performance materials¹⁷ Perfluorocarbons have also found many uses in medicine, examples include blood substitutes and ultrasound contrast agents.¹⁸⁻²⁰ Example fluorocarbon compounds and their use are presented in table 1.4.

Table 1.4: Applications of fluorine containing materials

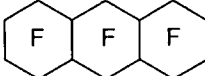
Application	Example
Anaesthetics	CF_3CHBrCl , Fluothane TM $\text{CHClFCF}_2\text{OCHF}_2$, Enflurane TM
Inert Fluids	
Polymers	$-(\text{CF}_2\text{CF}_2)_n-$, PTFE $-(\text{CF}_2\text{CClF})_n-$, PTFCE
Refrigerants	$\text{CF}_3\text{CH}_2\text{F}$

Several reasons exist for the inclusion of fluorine atoms into biologically active molecules;²¹ the introduction of fluorine can influence the distribution, clearance, extent of metabolism, and interaction with the pharmacological target. Furthermore, the development of sophisticated non-invasive techniques based on fluorine NMR and positron emission topography allows the study of fluorinated drugs *in-vivo*. Areas of treatment include antidepressants, anti-inflammatory, antimalarial, antibiotics, antipsychotics, antiviral, and anaesthetics. Examples of fluorinated drugs are given in figure 1.3.

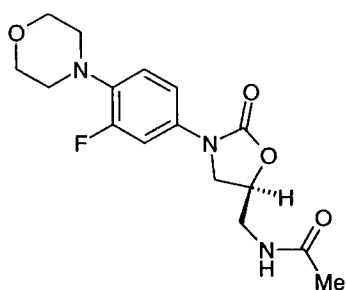

Linezolid, (Zyvox[®], Pharmacia and Upjohn)

Antibiotic²²

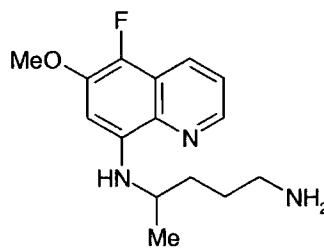

5-Fluoroprimaquine,

Antimalarial²³

Fig 1.3

1.6 The Isolation of Fluorine: A Brief History

Fluorine derives its name from the early use of fluorspar (CaF_2), which was described by Agricola as a flux (Latin *fluor*, flowing) in 1529. Later in 1670, Schwandhard found that glass was etched when exposed to fluorspar treated with strong acid. Scheele first identified fluorine in 1771, although he did not isolate the element in its pure form, but as a crude preparation of hydrofluoric acid. Numerous other workers have also tried unsuccessfully to isolate fluorine, including Davy, Faraday, Gay-Lussac, Lavoisier, Thenard, and Frémy.^{5, 24}

Davy's attempt involved passing an electric current through hydrofluoric acid containing water. Although no fluorine was evolved, he observed that the electrical resistivity increased with decreasing water content. Frémy is known chiefly for the preparation of a salt, which is named after him 'Frémy's salt' and consists of KF.HF . Frémy's salt allowed the preparation of relatively pure hydrofluoric acid upon thermal decomposition. Frémy also conducted electrochemical experiments with pure hydrofluoric acid and found that the pure acid could not be electrolysed. He also conducted experiments in platinum apparatus using molten salts of potassium and calcium fluoride and succeeded in generating a small amount of a pungent gas, which was probably fluorine before rendering the apparatus unusable.

The actual isolation of fluorine was attributed to Moissan in 1886 where fluorine was obtained from the electrolysis of hydrofluoric acid containing a small amount of

potassium fluoride derived from Frémy's salt. As a result of that work, Moissan became the first elemental fluorine experimentalist.

Many other workers have made important contributions to the fluorine preparation process, although, Cady's method involving the electrolysis of $\text{KF}\cdot 2\text{HF}$ is effectively the process used currently (See Section 1.7.2).^{5, 24, 25}

1.7 Production of Fluorine

Fluorine is produced by the electrolysis of molten $\text{KF}\cdot 2\text{HF}$ and has been discussed in the literature at great length. For a comprehensive discussion the reader is directed to that literature and to the references cited therein.²⁵⁻³²

1.7.1 Generation of Hydrogen Fluoride

As briefly described in section 1.6, hydrofluoric acid is an important intermediate in the manufacture of elemental fluorine, which is generated by heating a mixture of sulfuric acid and fluorspar (CaF_2), as can be seen in Figure 1.4.

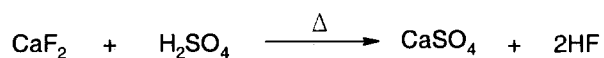

Fig 1.4

A limited source of hydrofluoric acid has also been derived from depleted uranium hexafluoride, a by-product of the uranium-235 enrichment process.^{33, 34}

1.7.2 Production of Fluorine by Electrochemical Methods

Industrial scale fluorine production did not exist until world war II, when at that time, fluorine was required for the manufacture of enriched uranium-235 via the generation of UF_6 , and in the materials for handling the aforementioned compound.³⁵ As briefly mentioned in section 1.7, fluorine is prepared by the electrolysis of a $\text{KF}\cdot 2\text{HF}$ molten mixture, at a temperature between 72-110°C. Addition of a small quantity of lithium fluoride to the electrolyte or the use of porous anodes improves the fluorine cell operation. Since fluorine production is continuous and not a batch process, hydrogen

fluoride is continually passed into the electrolyte at such a rate that the composition of the electrolyte is always constant.

Other small scale methods have been described for fluorine generation. The electrolysis of a solid mixture of LaF_3 containing between 3-10 mol % of BaF_2 evolves fluorine.³⁶ Alternatively, fluorine has been evolved at n-type TiO_2 electrodes when in an anhydrous hydrofluoric acid/ sodium fluoride solution. This process also requires irradiation with electromagnetic radiation at 365 nm, which matches the band gap of the electrode.³⁷

1.7.3 Production of Fluorine by Chemical and Other Methods

Various chemical means of producing fluorine have been described in the literature. A fluorine containing chlorine-oxy compound,³⁸ and the di- and tri-oxygen difluorides have been found to produce fluorine upon their decomposition.³⁹ Several tetrafluoroammonium salts and transition metal fluorides also produce fluorine upon displacement with Lewis acids.⁴⁰⁻⁴³ In fact, one transition metal complex has been used to recover fluorine from fluorine containing waste gas streams.⁴⁴ Fluorine is liberated by the decomposition of alkali metal fluorochlorides.⁴⁵ Highly fluorinated fullerenes have also been observed to eliminate fluorine in prolonged storage in solvent and at elevated temperatures.⁴⁶ Figure 1.5 depicts some of the aforementioned preparations of elemental fluorine.

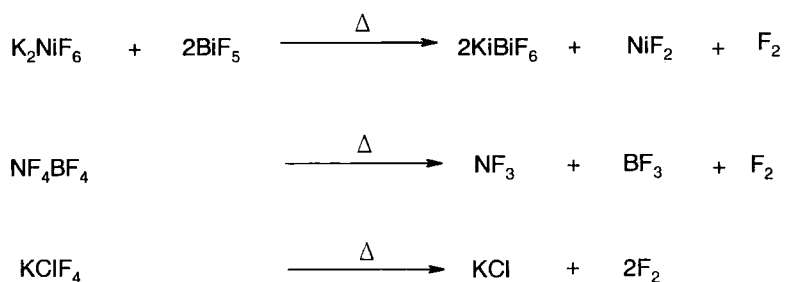

Fig 1.5

However, it should be noted that, none of the above compounds are found naturally and they cannot be made without elemental fluorine, hence electrolysis is only practical route to elemental fluorine.

1.8 Electrophilic Fluorination of Organic Compounds

It is not the aim of this thesis to comprehensively review electrophilic fluorination by reagents other than elemental fluorine. Several reviews have already been published, which more than adequately cover these areas and the reader is directed to that literature and to the references cited therein.⁴⁷⁻⁵⁰

Radical fluorination, an important alternative fluorination procedure, will be briefly described in this thesis, so as to place the work of electrophilic fluorination into context.

Fluorination by the use of electrochemical methods⁵¹⁻⁵³ or high valent transition metal fluorides⁵⁴ has been reviewed previously and the reader is directed to that literature and to the references cited therein.

1.8.1 Radical Fluorination of Organic Compounds

Direct fluorination of organic compounds under radical conditions proceeds via a chain reaction (See Table 1.5).^{55, 56} Propagation and termination steps being highly exothermic, more than offset the endothermic fluorine-fluorine bond cleavage initiation step. The energy released in the termination step is sufficient to cause carbon-carbon bond cleavage (C-C bond strength 346kJmol^{-1}) and consequently, if the reaction is not controlled and this energy is not dissipated quickly enough, carbon-carbon bond cleavage will prevail.

Table 1.5: Fluorine and Chlorine Radical Enthalpy

Step	Reaction	X = F	X = Cl
		ΔH (kJmol ⁻¹)	ΔH (kJmol ⁻¹)
Initiation			
1	$X_2 \longrightarrow 2X^\bullet$	+159	+243
Propagation			
2	$RH + X^\bullet \longrightarrow R^\bullet + HX$	-131	+8
3	$R^\bullet + X_2 \longrightarrow RX + X^\bullet$	-314	-107
Termination			
4	$R^\bullet + X^\bullet \longrightarrow RX$	-472	-349
5	$R^\bullet + R^\bullet \longrightarrow RR$	-351	-351

Numerous radical fluorination reactions proceed vigorously at ambient temperature, but fluorine molecules are known to be only slightly dissociated at this temperature (See Fig 1.6). This led early workers to propose an alternative initiation process as illustrated in Fig 1.7.⁵⁷⁻⁵⁹



Fig 1.6

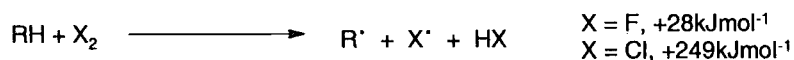

Fig 1.7

Radical fluorinations are known to be unselective with respect to chlorine and bromine radicals. The selectivity of fluorine, chlorine, and bromine radicals is presented in table 1.6. It follows therefore, that extremely reactive fluorine radicals are not desired for the selective fluorination of organic compounds.

(F_2H^+) resembles that of a complex between F^+ and HF,⁷³ the ground state of which is predicted to be a triplet. However, ground state triplets are seldom invoked as intermediates in electrophilic halogenation reactions, and indeed, one would expect them to suppress radical processes by simple analogy to radical reactions carried out in the presence of oxygen. Molecular oxygen possessing a triplet ground state, suppresses radical reactions, and therefore thoroughly degassed solvents are required in order to perform free radical reactions. Recently, a condensed phase theoretical study has been applied to homolytic/ heterolytic bond breaking processes in polyethers. The study concluded that heterolytic cleavage is preferable in protic media. The approach of a solvent proton carrying a partial positive charge favourably localised the two electrons of the bond in question, at one side of the bond.⁷⁴

These aforementioned observations, suggest that electrophilic fluorination would take place more favourably in strong acid. Interestingly, fluorination in strong acids results in high conversions and yields of fluorinated products, which are suggestive of electrophilic processes.⁶⁵ Attempted electrophilic fluorination undertaken in non-acidic/ polar media, usually results in intractable material. Further proof for the existence of electrophilic fluorine has been provided recently.⁷⁵ Selectfluor[®], a commercial N-F reagent, has been shown to unambiguously react in an electrophilic manner. Furthermore, a theoretical treatment concerning fluorination of an aromatic compound also revealed that fluorination occurs via a S_N2 mechanism having a transition state involving nucleophilic attack on fluorine, i.e. fluorine is electrophilic in nature.⁷⁶

Fluorination performed in highly polar/ acidic media is further complicated by two possible electrophilic pathways,⁷⁷ which are unfortunately difficult to distinguish between, as depicted in figure 1.9. The two possible routes are: i) fluorine interacts with solvent, or ii) fluorine forms an intermediate species with the solvent, such as an O-F intermediate. That being so, the partial involvement of both mechanisms cannot be dismissed, and indeed neither proposed pathway disagrees with the concept of electrophilic fluorination.

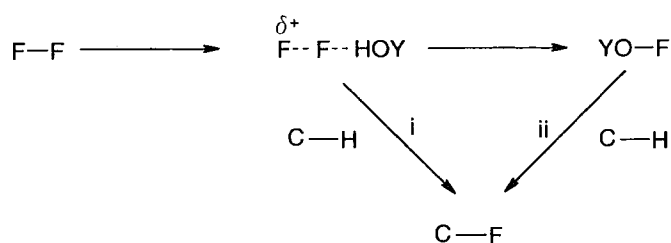

Fig 1.9

1.9 Direct Fluorination Using Elemental Fluorine (1996-Present)

To provide good review overlap, published work involving the use of elemental fluorine will be reviewed thoroughly from 1996 to the present day; work published before 1996 has been reviewed thoroughly by several other workers and the reader is directed to that literature and to the references cited therein.^{65, 78-80} The order of the literature presented here in this discussion, will be influenced by chronological factors.

1.9.1 Direct Fluorination of Aromatic Compounds

The direct fluorination of 4-fluorobenzoic acid has been studied in a wide range of solvents by Chambers.⁷⁷ The highest yields of 3,4-difluorobenzoic acid can be obtained by using either sulfuric or methanoic acids. On the other hand, solvents having a low permittivity/ low acidity, such as 1,1,2-trichloro-1,2,2-trifluoroethane and 2,2,2-trifluoroethanol, performed poorly, having none or little conversion to 3,4-difluorobenzoic acid. However, one can assume that high proportions of uncharacterised material was produced in these solvents as a result of unselective reactions.⁷⁷

Further work by Chambers and Moilliet, demonstrated that direct fluorination of a wide range of 1,2-, 1,4-, and 1,3,4-substituted benzenes may be carried out efficiently, if methanoic/ sulfuric acids are used as the reaction medium (See Figs 1.10 and 1.11).⁸¹⁻⁸⁵

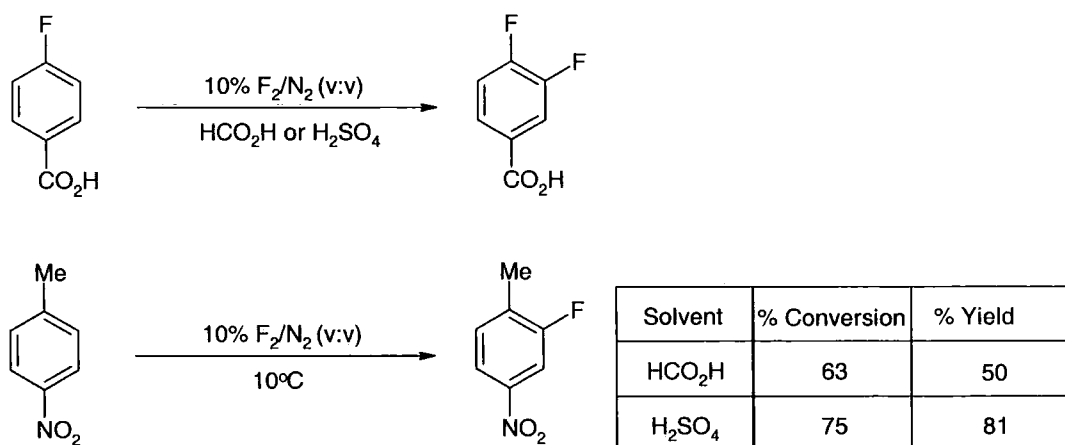

Fig 1.10

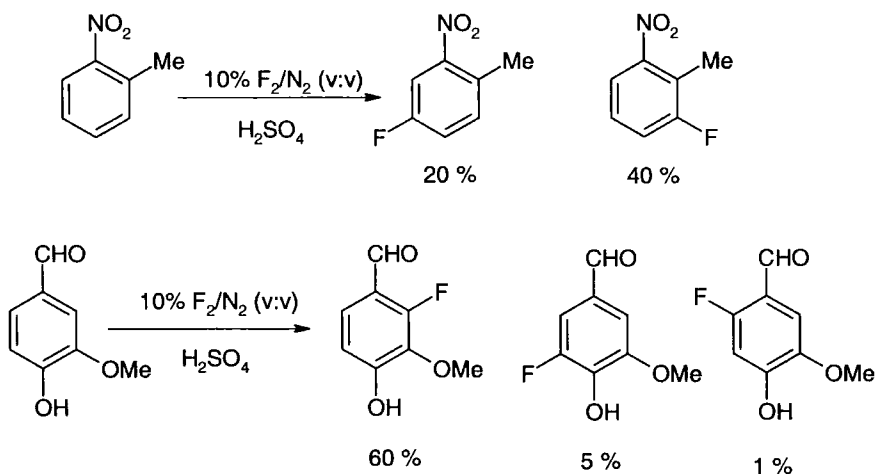

Fig 1.11

Pasenok has also found that the direct fluorination of 1,4-disubstituted benzenes could be achieved efficiently when performed in polyfluoroalkylsulfonic acids.^{86, 87} Later work by Bowden showed that hydrofluoric acid/ water⁸⁸ mixtures were also excellent reaction solvents (See Fig 1.12). Direct fluorination reactions performed in hydrofluoric acid/ water mixtures were most efficient when 80% HF solutions were used.

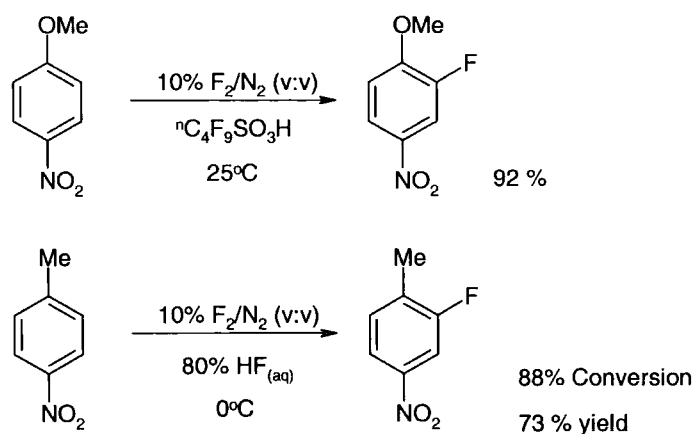

Fig 1.12

Chirakal has reported the synthesis of ^{18}F labelled derivatives of L-DOPA by the use of $[\text{}^{18}\text{F}]\text{F}_2$ (See Fig 1.13).⁸⁹ Interestingly, the regioselectivity of fluorination differed depending on the type of medium used. Use of HF or HF/BF₃ as reaction medium gave the 2- and 6-FDOPA derivatives as major products in a 1:2 ratio respectively. However, the use of trifluoroacetic acid (TFA), methanoic acid, ethanoic acid, or mixtures thereof, as reaction medium, resulted in the 2- and 5-FDOPA derivatives being the major products, generally in roughly equal proportions.

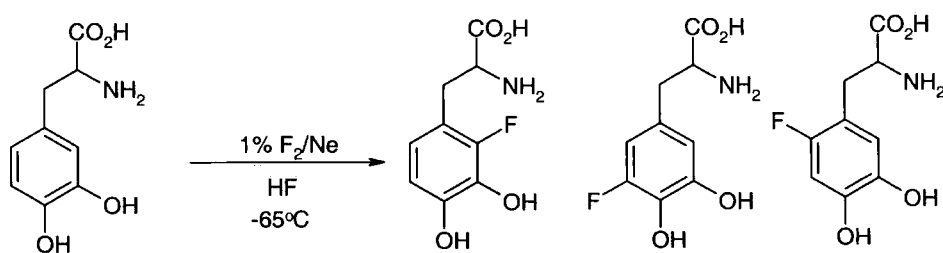

Fig 1.13

The regioselectivity for the 2- and 6- positions in strong acid was rationalised by neighbouring group assistance by the $-\text{NH}_3^+$ group, figure 1.14 shows the proposed involvement. Direct fluorination in strong acid resulted in participation of the $-\text{NH}_3^+$ group, and hence, preferred fluorination at the 2- and 6-positions. On the other hand, use of weaker acids resulted in fluorination at positions *ortho* to the hydroxyl groups, namely the 2- and 5-positions.

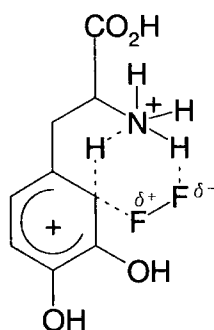

Fig 1.14

The extent to which fluorination occurred in the reaction, was found to be high for strong acids and low for weaker acids; for example, radiochemical yields obtained using HF or HF/BF₃ mediums, were 30 and 40% respectively. However, this contrasts to 0 and 6% yield in ethanoic and methanoic acids respectively (Maximum radiochemical yield achievable using [¹⁸F]F₂ equals 50%).

Furthermore, the preparation of ¹⁸F labelled L-tyrosine and L- α -methyltyrosine has been achieved using a similar methodology (See Fig 1.15).⁹⁰ Fluorination was performed in a range of solvents, although highest radiochemical yields were obtained using TFA or anhydrous HF. Radiochemical yields were found to be 28 and 30% respectively, for TFA and anhydrous HF.

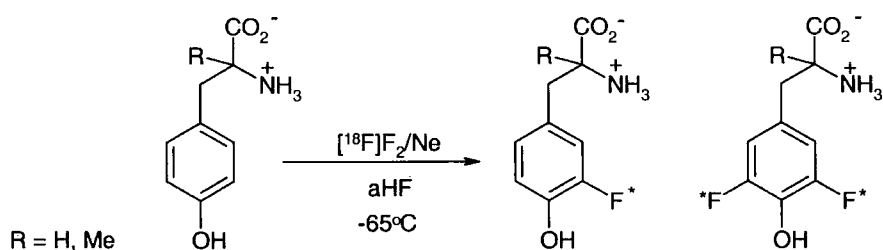

Fig 1.15

Chambers has also reported the direct fluorination of aromatic compounds using nitric acid as reaction medium.⁹¹ Although, fluorination in nitric acid led to the formation of nitrated derivatives (See Fig 1.16), in fact, fluoro-nitration took place.

Conversions were quantitative under the reaction conditions, although yields of fluorinated products were moderate.

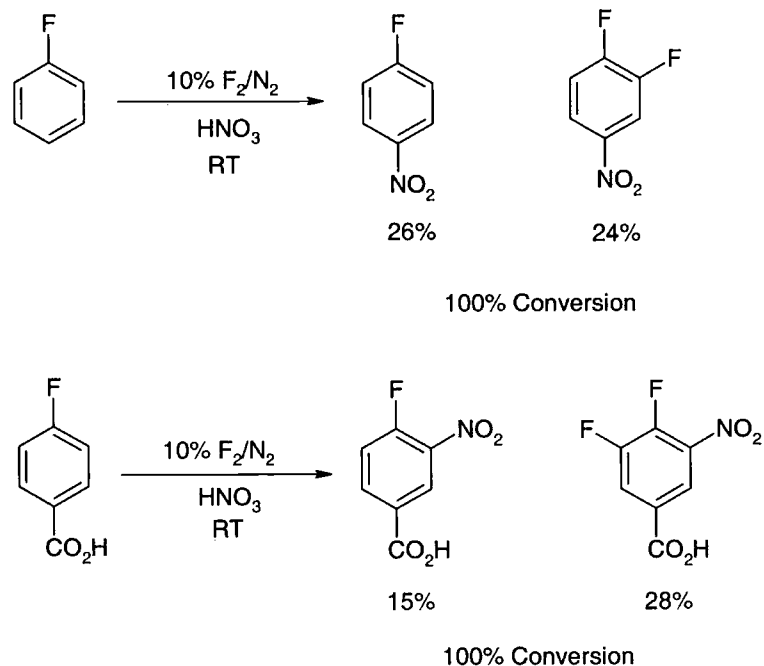

Fig 1.16

The fluorodesilylation of 4-fluorotrimethylsilylbenzene has been reported by Coe and Stuart to give 1,4-difluorobenzene as the major product. However, early experiments whilst giving high conversions, unfortunately gave undesirable yields of fluorodesilylated products.^{92, 93} Subsequent experiments showed that addition of boron trifluoride, or the addition of acid improved the yields by encouraging electrophilic substitution of the –SiMe₃ group by assisting fluorine polarisation. As well as the major product, there was also significant quantities of 2,5-difluorotrimethylsilylbenzene formed by envisaging ipso attack by fluorine at the silyl position, followed by a 1,2-migration of the silyl group. The driving force for the migration is thought to be carbocation stabilisation. Unsurprisingly, the respective fluorination of 2- and 2,4-difluoro silyl derivatives under similar conditions also gave poor results.

Greenhall has been able to fluorinate several naphthalene derivatives by direct fluorination methodology,⁹⁴ using acetonitrile and methanoic acid mediums. One

equivalent of fluorine gave a low conversion (37%), although a high selectivity for the monofluoro derivative was achieved (85%). The formation of a significant quantity of a demethylated geminal-difluoro by-product, was also observed (See Fig 1.17). Higher equivalents of fluorine increased the conversion, (2 equivalents, 81% conversion) although at the expense of the monofluoro derivative (46% Yield).

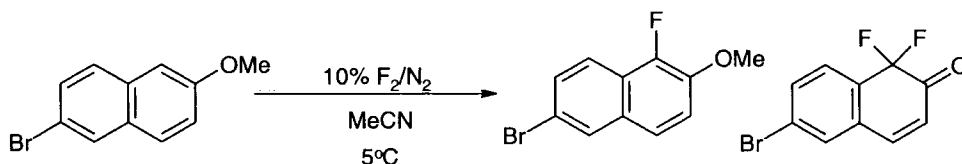

Fig 1.17

The high temperature direct fluorination of [60]fullerene, in the presence of nickel and manganese (II) fluorides has been studied by Chilingarov.⁹⁵ Over short reaction periods the addition of MnF_2 was found to promote selective formation of $\text{C}_{60}\text{F}_{18}$, whilst over longer periods, $\text{C}_{60}\text{F}_{18}$ was found to be the major product. Selectivity is thought to be due to the adsorbance of fluorine onto the MnF_2 surface, whereby it reacts with C_{60} , rather than via higher manganese fluorides. Other work performed by Touhara has demonstrated that the internal surface of carbon nanotubes may be selectively fluorinated if the outer surface is protected by an inert material.⁹⁶

Elemental fluorine has also been used to accomplish bromination, chlorination, and iodination of a range of aromatic compounds (See Fig 1.18).^{97, 98} Chambers found halogenation involving bromine, chlorine and iodine behaved in an analogous manner to fluorination, in that the highest conversions and yields were obtained when strong acid was used as reaction medium. Moreover, it was subsequently found that high conversion and yields could also be obtained if a relatively small amount of sulfuric acid was used in conjunction with a co-solvent such as $\text{CF}_2\text{ClCCl}_2\text{F}$. However, the use of inter-halogen compounds resulted in the formation of mixed halogen products in roughly equal proportions.

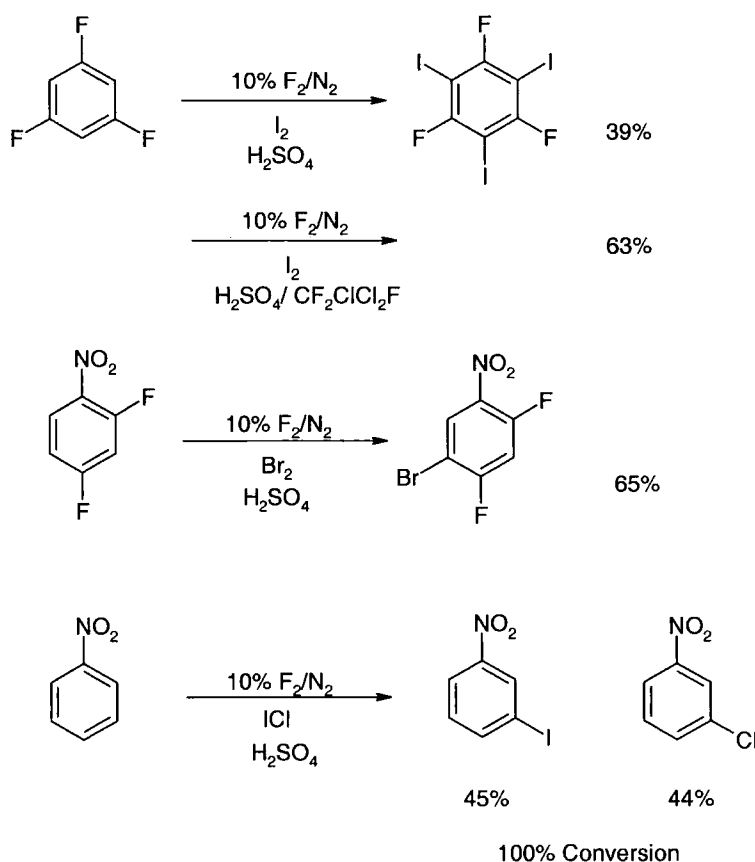

Fig 1.18

1.9.2 Direct Fluorination of Heteroaromatic Compounds

Fluorination and halogenation of quinolines and 2H-chromen-2-ones is highly relevant to this thesis and will be discussed in detail, in chapters 2 and 3.

Very little work has been published concerning the direct fluorination of heteroaromatics, since the last review of the area.⁶⁵ However, Barrio has reported that the direct fluorination of several purine derivatives resulted in the formation of 8-fluoropurines, in reasonable yield (See Fig 1.19). The procedure was also used in the preparation of ¹⁸F derivatives.^{83, 99-101}

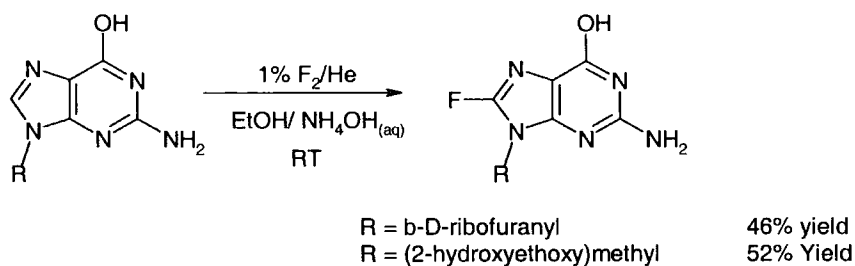

Fig 1.19

1.9.3 Direct Fluorination of Hydrocarbons

The selective electrophilic fluorination of a range of hydrocarbons has been reported. Chambers reports that fluorination could be achieved in acetonitrile, using 10% F_2 at 0°C .^{102, 103} Conversions and yields were moderate to good, but where compounds possessed a number of similar sites, fluorination resulted in mixtures of products (See Fig 1.20). Furthermore, no fluorination was observed at primary C-H sites.

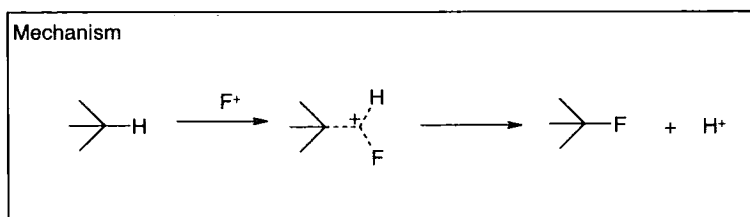
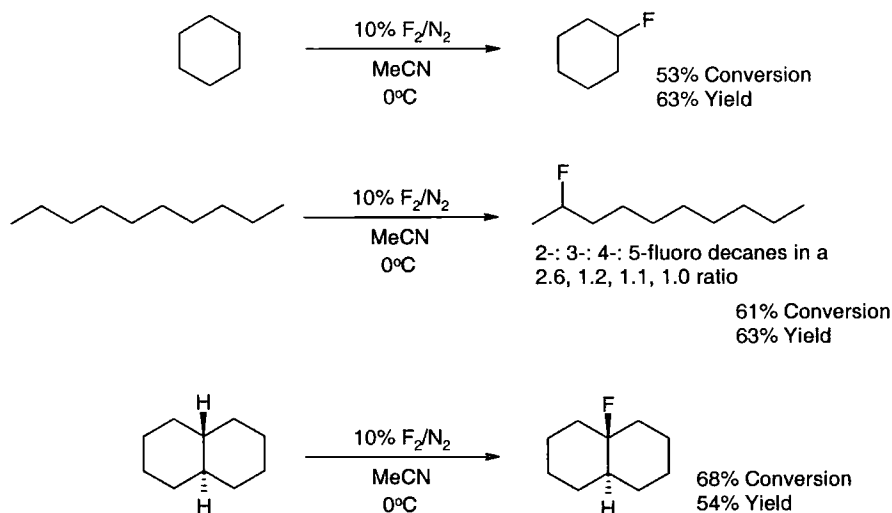

Fig 1.20

Interestingly, retention of stereochemistry was observed when tertiary C-H bonds were fluorinated. This phenomenon was rationalised by electrophilic attack by "F⁺" on the C-H bond via a three-centre-two-electron bonded intermediate. Similar work, found that the fluorination of hydrocarbons in the presence of boron trifluoride resulted in the formation of amide derivatives (See Fig 1.21),¹⁰⁴ which was rationalised by initial fluorination, followed by Lewis acid assisted ionisation. Subsequent nucleophilic attack by acetonitrile and aqueous work-up, finally gave amide products.

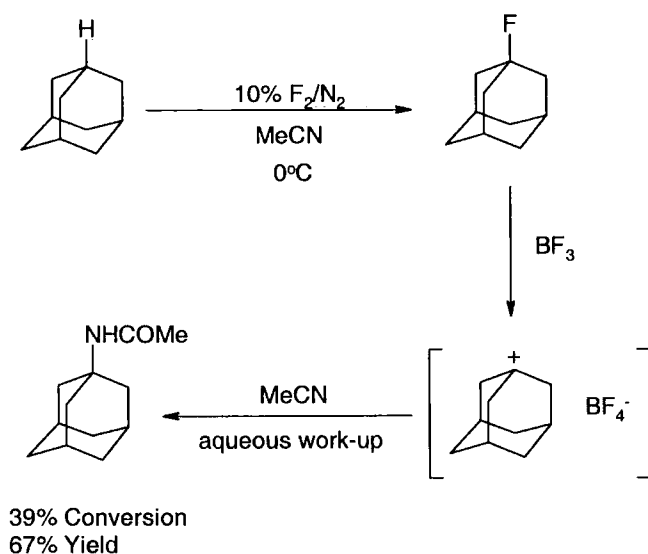

Fig 1.21

Recently, the direct fluorination of 1,4-disubstituted cubane derivatives has been described by Lagodzinskaya,¹⁰⁵ where 2-fluoro-1,4-disubstituted derivatives were obtained, as well as several difluorinated isomers (See Fig 1.22). Initial experiments performed in TFA were unsuccessful and the addition of sodium or potassium ethanoates was required. Fluorination is subsequently thought to occur by the *in-situ* formation of acetyl hypofluorite.

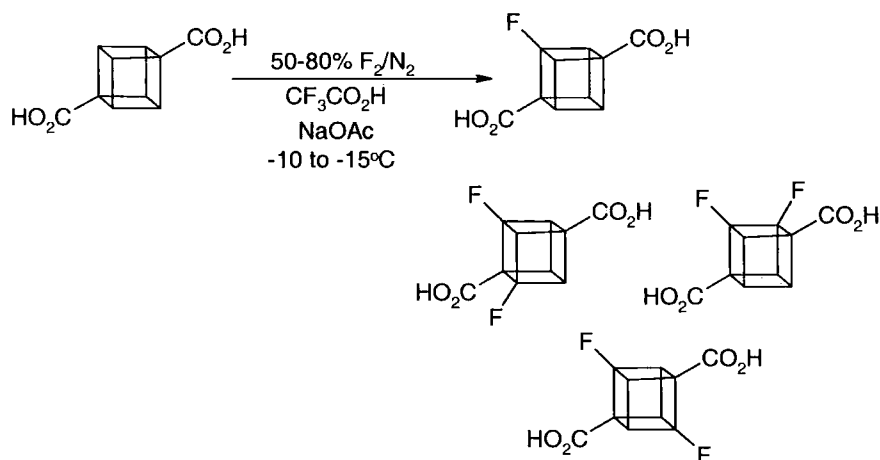

Fig 1.22

1.9.4 Direct Fluorination of Carbonyl Compounds

Direct fluorination of carbonyl compounds, in particular, 1,3-dicarbonyl derivatives with elemental fluorine has been reported. Chambers has found that high conversions and yields of fluorinated products can be obtained if fluorination is performed in methanoic acid.^{106, 107} Fluorination of 1,3-dicarbonyls resulted in the formation of 2-fluoro derivatives (See Fig 1.23), although, 2,4- and 2,2-difluoroderivatives were also formed, the latter of the two being produced only if both substituents on the 2-position were hydrogen.

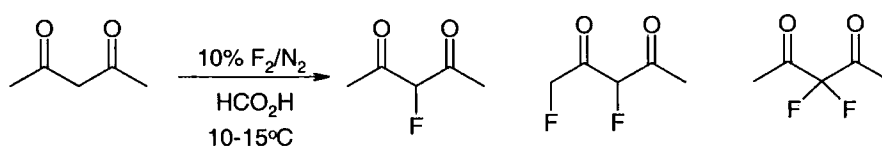

Fig 1.23

Furthermore, the extent to which fluorination took place was found to be directly related to the enol content of the dicarbonyl. For instance, for carbonyl compounds where the rate of enolisation was high or the enol content was high, then high yields of fluorinated products were obtained. However, the opposite was true when the enol content/ rate of enolisation was low. The reactivity order was found as follows: 1,3-diketones > 1,3-ketoesters > 1,3-diester, the 1,3-diester being unreactive under

analogous reaction conditions. That being so, high yields of fluorinated 1,3-diester derivatives can be obtained by fluorinating the sodium salt of the 1,3-diester.¹⁰⁸⁻¹¹⁰

Recently, various workers have published modifications and improvements to the dicarbonyl fluorination methodology. The effects of changing fluorine concentration and fluorine flow rate have been described by Ishihara,¹¹¹ where preferred results were obtained if during the reaction, the flow rate of dilute fluorine increased, whilst at the same time, increasing the fluorine concentration. Bowden, has independently reported that the fluorination of 1,3-dicarbonyls may be achieved in high yield when HF/water mixtures are used,⁸⁸ whilst Casteel reports that $F_2/N_2/O_2$ gas mixtures are advantageous.¹¹² Furthermore, Umemoto has described that the fluorination of 1,3-dicarbonyls in the presence of catalytic amounts of salts/acids, also produces high yields of fluorinated products,^{113, 114} and Nuki has reported the fluorination of dicarbonyls as solventless reactions containing small amounts (up to 10%) of various acids.¹¹⁵

Further work by Chambers, has demonstrated that the preparation of fluorinated phosphonates may be achieved by using similar fluorination methodology.¹¹⁶

Additional work by Chambers has also described the fluorination of cyclic ketones, he mentions that cyclic 2,2-difluoro-1,3-dicarbonyl derivatives were formed readily, due to their high ability to enolise again after initial mono-fluorination (See Fig 1.24).¹¹⁷ However, the formation of the analogous 2,2-difluoro open chain systems is prevented due to slow enolisation after initial mono-fluorination.

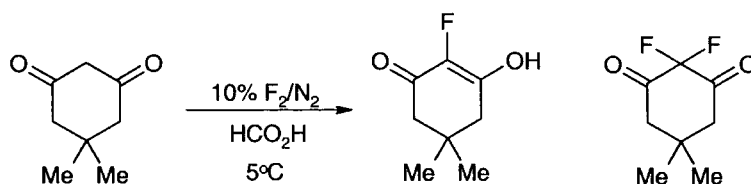

Fig 1.24

A preparation that enables the exclusive synthesis of monofluorinated dicarbonyl derivatives has been reported by Sato (See Fig 1.25),¹¹⁸ where the direct fluorination of α -hydroxymethylene substituted 1,3-dicarbonyls, which mainly exist in their enol form,

results in the generation of a monofluoro derivative. This intermediate then undergoes facile deformylation to give an un-substituted 2-fluoro-1,3-dicarbonyl system. This process appears to be limited to diester derivatives, due to the fact that the diketo and ketoesters could feasibly undergo fluorination to give undesired 2,4-difluoro derivatives, as described earlier by Chambers.^{106, 107}

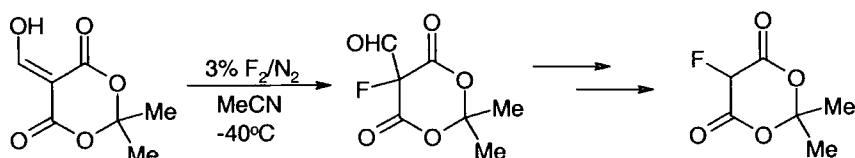

Fig 1.25

Chambers has used a somewhat similar methodology, i.e. the use of trapped enols, such as silyl ether and enol acetates, to prepare α -fluorocarbonyl compounds (See Fig 1.26).¹¹⁹⁻¹²¹ The fluorination of enol acetates/ silyl ethers in acetonitrile or methanoic acid was found to give high conversions and good yields of α -fluorocarbonyl compounds.

Fluorine has also been used to prepare fluorinated 1,3-ketoamides, with acetonitrile or methanoic acid as reaction solvent, although highest yields of 2-fluoro adducts were obtained in methanoic acid.¹²²

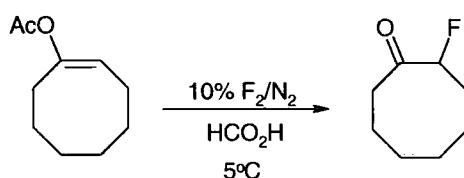

Fig 1.26

Further work, has described that the fluorination of carbonyl compounds may be catalysed by the addition of transition metal salts to the reaction, in particular copper (II) salts.^{123, 124} Catalysis was only found to be possible when the fluorination was performed in acetonitrile, where the catalytic effect of the transition metal was explained based on the fact that metal ions complexed with the carbonyl compound, thereby increasing the rate of enolisation.

1.9.5 Direct Fluorination of Alkene Compounds

The preparation of *exo* and *endo* difluorides of 2-cyano-7-oxabicyclo[2.2.1]hept-5-en-2-yl acetate has been described by Toyota.¹²⁵ Fluorination was performed using 5% F₂/N₂ at low temperature (-78°C) (See Fig 1.27). The *exo*-difluorinated derivative was found to be the major product, whilst the *endo*-difluorinated product constituted a minor component; yields were 53 and 9% respectively.

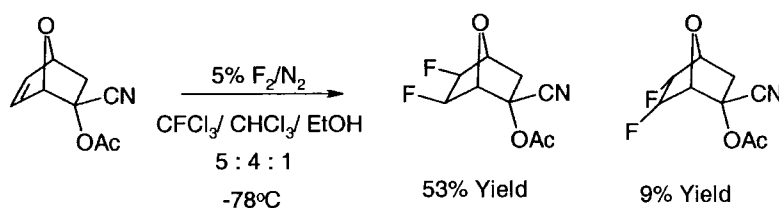

Fig 1.27

The fluorination of highly electron rich alkenes has also been reported, where Chambers describes that the formation of fluoride salts may be achieved by the direct fluorination of tetrakis(dimethylamino)ethene (See Fig 1.28).¹²⁶

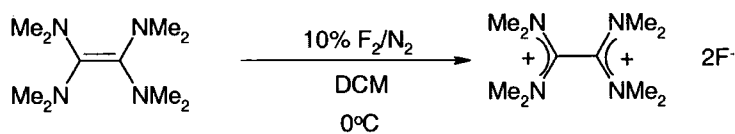

Fig 1.28

Feiring has found that the direct fluorination of aryl substituted perfluoroalkenes, gave perfluoroalkyl derivatives in poor to moderate yields (21-60%) (See Fig 1.29).¹²⁷ Direct fluorination was found to be successful if performed at a low temperature, and with a low concentration of fluorine in nitrogen (1.5%). The use of higher concentrations of fluorine resulted in a complicated mixture due to aryl ring fluorination. Improved yields of arylperfluoroalkanes were observed if the aryl ring possessed electron-withdrawing groups, which deactivate the ring toward electrophilic substitution.

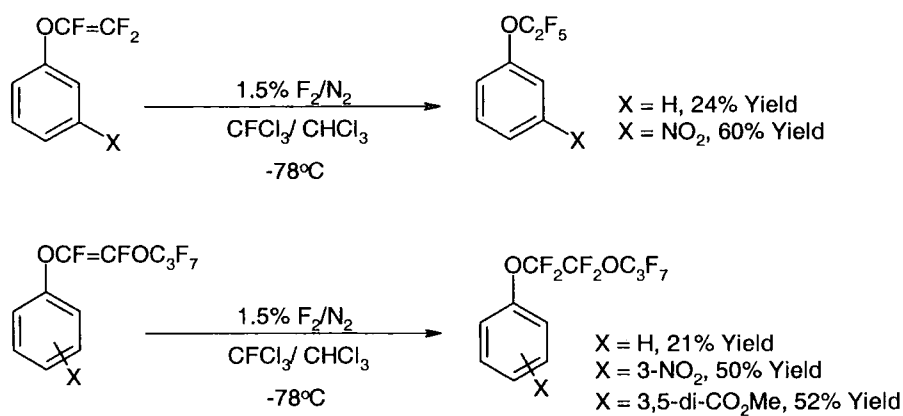

Fig 1.29

The direct fluorination of un-fluorinated, partially fluorinated, and perfluoroalkenes has been described by Moldavskii,¹²⁸ who studied gas and liquid phase fluorination. Perfluoroalkenes were found to give far superior yields of the desired perfluoroalkanes than their hydrocarbon counterparts (See Table 1.7). The fluorination of perfluoroalkenes in an inert solvent, usually the perfluoroalkane product, resulted in far less decomposition, due to reduced localised hotspot formation. The solubility of fluorine would also be improved in this reaction by the use of the perfluoroalkane solvent. The addition of CuF₂ and CoF₃ as catalysts were also found to be beneficial for liquid phase fluorination.

Table 1.7: Gas and liquid phase fluorination of alkenes

	Alkene	Solvent	Major Products (% Yield)	Reaction Conditions (°C)
Gas-Phase Fluorination	$\text{CF}_2=\text{CF}_2$	-	C_2F_6 (92); CF_4 (8)	-40 to 40
	$\text{CH}_2=\text{CH}_2$	-	C_2F_6 (8); CF_4 (86)	-40 to 30
	$\text{CF}_2=\text{CFCF}_3$	-	C_3F_8 (99); CF_4 (1)	-27 to 20
	$\text{CF}_3\text{CF}=\text{CFCF}_3$	-	C_5F_{12} (88); CF_4 (12)	0 to 60
Liquid-Phase Fluorination	$\text{CF}_2=\text{CFCF}_3$	none	C_3F_8 (92); CF_4 (6)	-26 to 22
	$\text{CF}_2=\text{CFCF}_3$	C_3F_8	C_3F_8 (>99); CF_4 (trace)	-26 to 22

1.9.6 Fluorination at Heteroatoms

1.9.6.1 Fluorination at Nitrogen Centres

The preparation of some N-fluoroaziridine derivatives has been discussed by Prati (See Fig 1.30),¹²⁹ fluorination under conditions which allowed H-bonding, ($\text{N-H}::\text{O}=\text{C}$) resulted in the exclusive formation of the N-fluoro derivative A. Fluorination under conditions where the H-bonding was not allowed, for example in the presence of triethylamine, resulted in the formation of a mixture of N-fluoro derivatives A and B. Likewise, the fluorination of the 3-trifluoromethyl analogue under H-bonding conditions gave the expected N-fluoro derivative A'. Unfortunately, fluorination of the 3-trifluoromethyl analogue under identical non H-bonding conditions resulted in unidentifiable products.

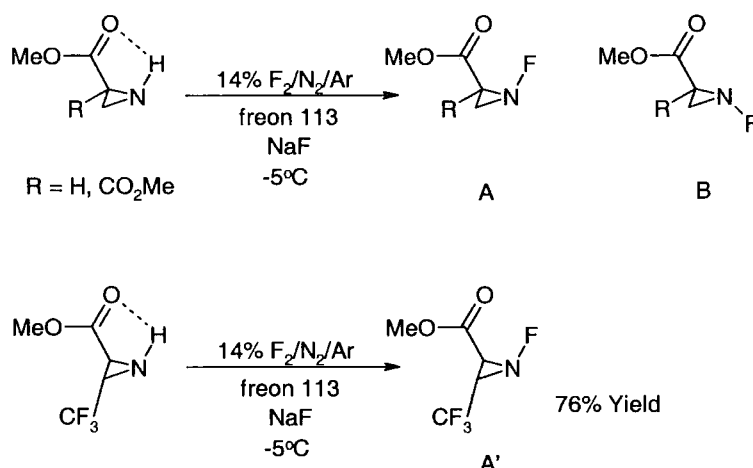

Fig 1.30

This was later rationalised on the basis that the addition of the $-\text{CF}_3$ group lowered the nucleophilicity of the aziridine nitrogen resulting in complications that stem from the fact that the triethylamine nitrogen would react preferentially with fluorine.

Many reports detail the preparation of numerous new N-F reagents, all of which were prepared by treatment of the parent compound, typically, secondary/ tertiary amines, pyridine derivatives, or amide alkali metal salts, with elemental fluorine. Yields of the N-fluoro products were generally high.¹³⁰⁻¹³⁶ The synthesis of some asymmetric N-F reagents has also been described.^{137, 138}

1.9.6.2 Fluorination at Oxygen Centres

Fluorination on oxygen can result in the generation of RO-F electrophilic fluorinating agents,⁴⁸ and in some cases, such as water, it is well documented that passing fluorine through a wet solution of acetonitrile results in the formation of a HOF.MeCN complex. This complex has been shown to be a powerful oxidising and epoxidising agent.^{139, 140} Further work, has demonstrated that secondary alcohols may be oxidised to their corresponding ketones by the action of elemental fluorine on the parent alcohol.^{141, 142} Moreover, the use of *in-situ* generated HOF.MeCN/ HOF.HCO₂H was found to be useful for affecting the transformation of ketones into esters, via a Baeyer-Villiger reaction.

1.9.6.3 Fluorination at Sulfur Centres

Recently, a convenient synthesis to substituted sulfurpentafluorides has been described. Bowden has reported, that by fluorinating a sulfur containing precursor (See Fig 1.31), sulfurpentafluorides be obtained in moderate yield.^{143, 144} Aryl-disulfides/thiols are found to undergo fluorination on sulfur, ultimately giving rise to aryl-SF₅ derivatives, via the formation of aryl-SF₃ intermediates. Higher yields of -SF₅ derivatives were obtained if the reaction was allowed to warm to room temperature during the reaction. Fluorination of the aryl-SF₃ intermediate was more efficient at higher temperature.

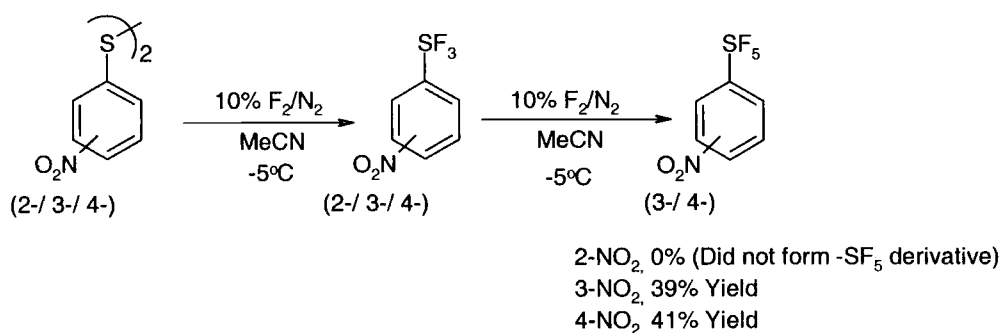

Fig 1.31

However, unlike the fluorination of 3-/4-nitrophenyl disulfides, which gave the corresponding -SF₅ derivatives, 2-nitrophenyl disulfides did not proceed further than the intermediate -SF₃ stage. In the case of aryl thiols, oxidation of the thiol to the disulfide was observed to occur first, before fluorination.

Klapötke has discussed the synthesis of fluoro azido-carbondisulfide from azido-carbondisulfide.¹⁴⁵ Fluorination of the aforementioned compound was performed at low temperature (-100°C) in SO₂ClF and gave a moderate yield (40%) of the fluorinated derivative (See Fig 1.32).

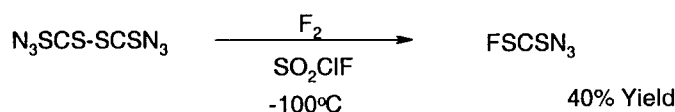

Fig 1.32

A preparation resulting in the synthesis of *cis*-2-fluorocyclopropane-1-carboxylic acid, starting from a sulfoxide precursor, has been described by Toyota (See Fig 1.33).¹⁴⁶ Initially fluorination took place on the sulfoxide sulfur, which was followed by the elimination of HF and fluorine migration to the cyclopropane ring. Further fluorination of the sulfoxide, followed by hydrolysis gave the sulfone, while reductive desulfonation gave the desired product.

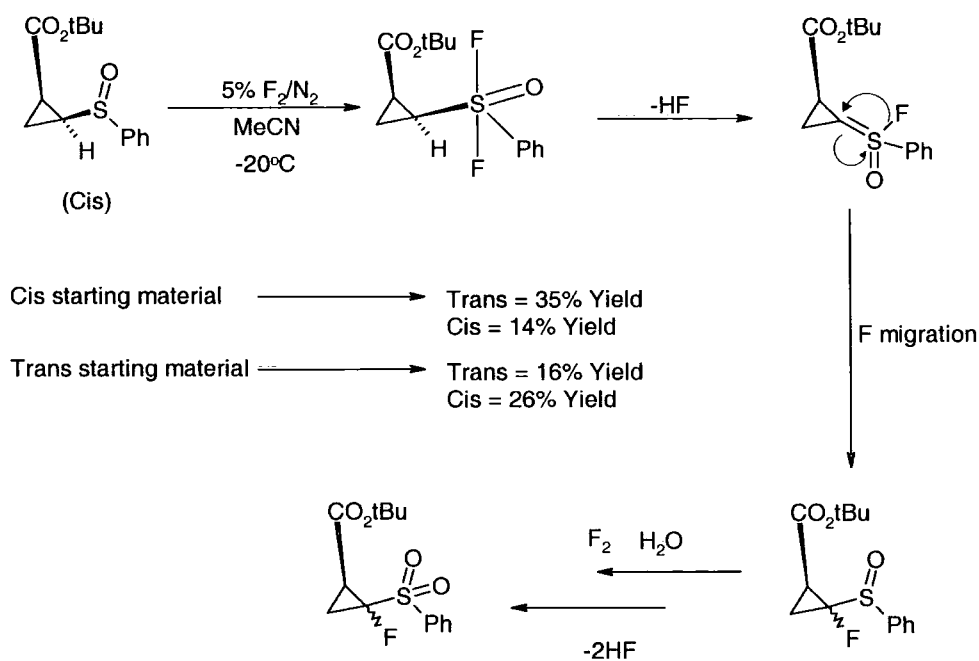

Fig 1.33

Chambers has reported that diaryl-1,3-dithiolanes can be converted into their corresponding difluoromethylene derivatives in high yields (69-81%) by treatment with fluorine and iodine (See Fig 1.34).¹⁴⁷⁻¹⁴⁹ Fluorine is bubbled through an anhydrous solution of iodine in acetonitrile, containing the 1,3-dithiolane.

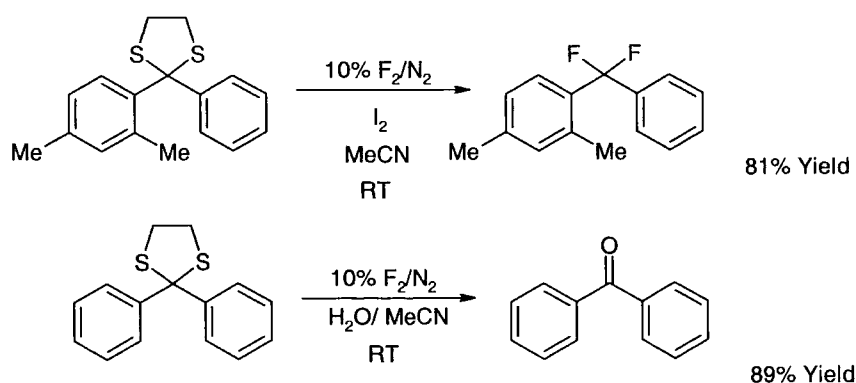

Fig 1.34

Interestingly, if the reaction is performed in the absence of iodine and in wet acetonitrile then difluoromethylene groups are not obtained, but instead, high yields (70-89%) of the corresponding ketones are obtained. However, the actual mechanism of ketone formation has not yet been established conclusively. Further work, investigated the ability of the fluorine/ iodine system to convert thio-glycosides into glycosyl fluorides which were obtained in moderate yields (40-57%).

1.10 Radical Fluorination of Organic Compounds

Several radical fluorinations have been reported and these may be classed into two distinct groups: partially fluorinated and perfluorinated compounds.

1.10.1 Partially Fluorinated Compounds

The radical fluorination of partially halogenated ethers, utilising porous aluminium fluoride (PAF) support, has been described by Sekiya (See Fig 1.35).¹⁵⁰ Fluorination of 1,1,2,2-tetrafluoroethylether gave α - and β -fluorinated products in 58 and 31% yield respectively, with a conversion of 32%. Fluorination of the related 2-chloro-1,1,2-trifluoro ethyl methyl ether gave α -fluorination in 95% yield with conversion being 29%. Repetition of the experiments under analogous conditions, but using a three-fold excess of fluorine, or without the porous aluminium fluoride support, resulted in charring.

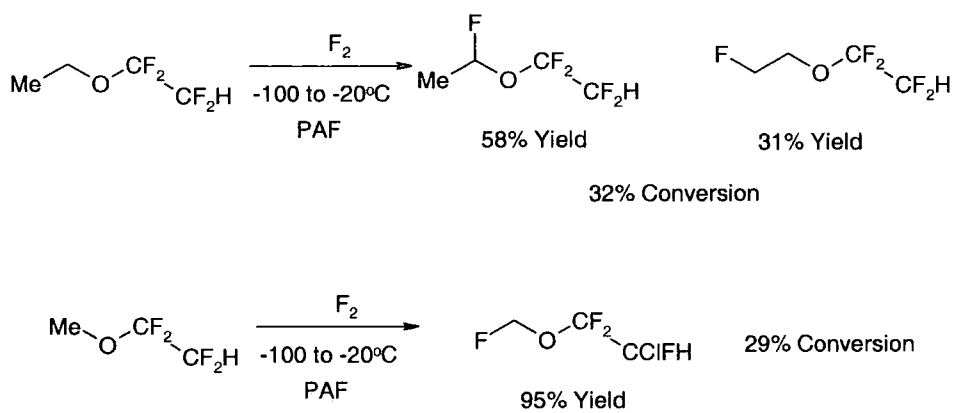

Fig 1.35

Ue has found that the solventless fluorination of γ -butyrolactone with 20% F_2 at 30°C gives α -, β -, and γ -fluoro derivatives in 15, 38, and 29% yield respectively, with a conversion of 60% (See Fig 1.36).¹⁵¹ Numerous difluoro by-products were also detected in this reaction, with a total composition of 17%.

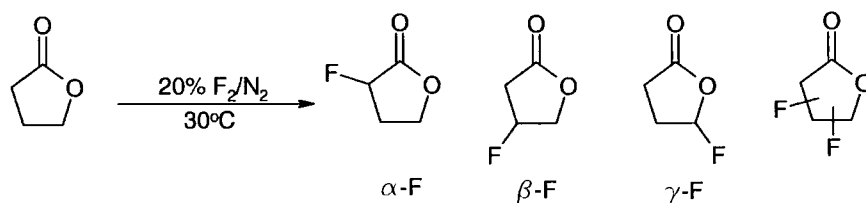

Fig 1.36

1.10.2 Perfluorinated Compounds

Adcock, Chambers, Lagow, and Moldavskii, have all reported the preparation of perfluoro compounds, namely: perfluoroalkanes,^{128, 152} perfluoro ethers,^{128, 153} perfluoro-crown ethers,¹⁵⁴ perfluoro-spiro-crown ethers,¹⁵⁵ perfluoroketones¹⁵⁶ and the first synthesis of a perfluoro-carbohydrate (See Fig 1.37).¹⁵⁷

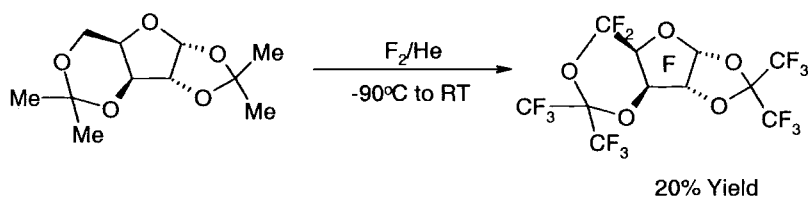

Fig 1.37

Unfortunately, yields of a majority of the aforementioned compounds were low, typically between 13-20%, the exceptions being perfluorocongressane and perfluoro-[30]-crown-10 ether, which were obtained in 45 and 50% yield respectively. Low yields were attributed to ring opening and to the presence of partially fluorinated derivatives. However, high yields of perfluorinated ethers and polyethers were achieved by the use of different fluorinating conditions (See Fig 1.38).¹⁵³ Partially fluorinated ethers and polyethers were found to be efficiently perfluorinated if fluorination was performed with the assistance of UV light or if fluorination was performed at a relatively high temperature (140°C). It is worth pointing out that the use of partially fluorinated compounds is due the fact that the introduction of partially fluorinated side chains lowers the reactivity of the molecule toward elemental fluorine, and hence enables smooth perfluorination to be achieved. The lack of the aforementioned groups would result in a vigorous reaction, and as a result, fluorinated tars and fragmentation products will be obtained.

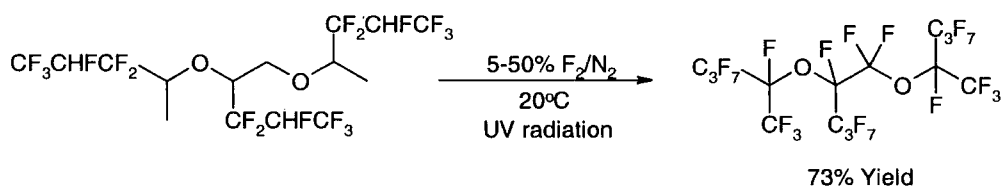

Fig 1.38

Fluorination performed with the assistance of UV light resulted in the best yield of perfluorinated material, typically between 50-73% yield. However, the fluorination of polyethers required the use of a partially fluorinated solvent, due to the viscosity of the polyether being very high. Both the polyether and the solvent underwent perfluorination

using the aforementioned reaction conditions. Complementary work has also been described by Moldavskii¹²⁸ who showed that the fluorination of partially fluorinated ethers and hydrocarbons occurred more efficiently in an inert solvent, in this case usually the perfluorinated product, than in the gas phase.

Okazoe has recently described an efficient synthesis of perfluoro(alkoxyalkanoyl) fluorides, which are then used in the synthesis of perfluorovinyl ethers.¹⁵⁸ The synthesis involves reacting a primary alcohol hydrocarbon with a perfluorinated acyl fluoride, which is actually used as the fluorination solvent, as shown in figure 1.39. Perfluorination is achieved by using F_2/N_2 mixtures between 20-50%, the resultant perfluorinated ester is then cleaved by sodium fluoride to yield two molecules of perfluorinated acyl fluoride. Thermal decarboxylation is then used to form perfluorovinyl ethers in 180% yield, based on the perfluorinated acyl fluoride starting material. The process has been given the acronym PERFECT, which is the abbreviation of perfluorination of an esterified compound then thermal elimination. The PERFECT process has been used to prepare several other perfluorinated acyl fluorides in generally high yield.

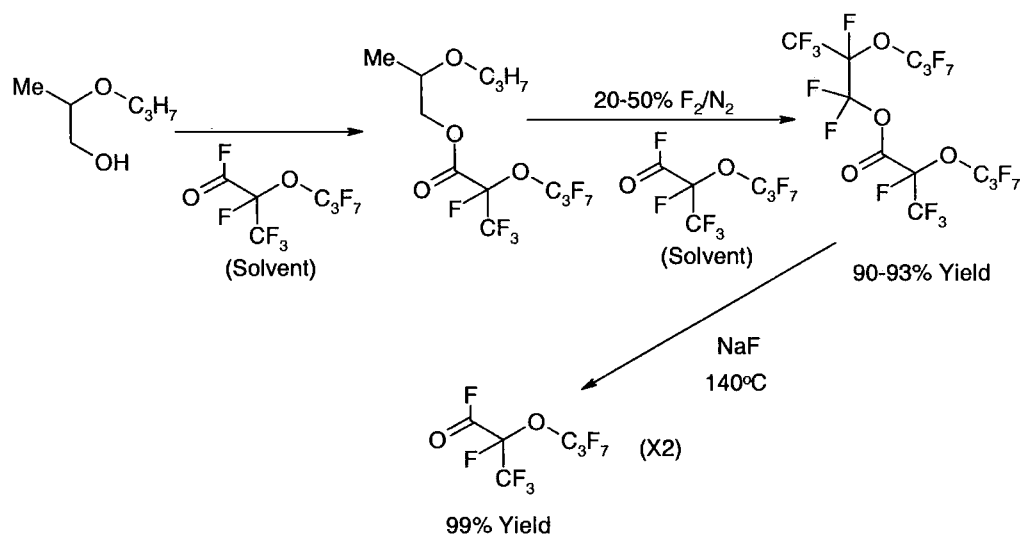

Fig 1.39

Recently, Pashkevich has studied the kinetics concerning the gas-phase fluorination of 1,1,1,2-tetrafluoroethane to perfluoroethane.¹⁵⁹ The reaction was found to

have autocatalytic character, which is related to the thermal dissociation of fluorine. It was also concluded that vibrationally excited HF might be the cause of the autocatalytic effect by encouraging the dissociation of fluorine. Furthermore, it was discovered that the radical chain is hindered by fluorine atoms adsorbing onto the reactor wall, thereby effectively reducing the concentration of fluorine atoms. Additional studies,¹⁶⁰ revealed that cycling the reaction temperature was beneficial to the reaction. The presence of HF in the reaction was not found to noticeably influence the reaction product distribution. Conversions and product selectivity can be maximised by diluting the fluorine, recycling the partially fluorinated products, and by the utilisation of a two/ three stage reactor.

1.11 Direct Fluorination Technology

Moissan, was first to observe the action of elemental fluorine on organic compounds,¹⁶¹ and concluded that most reactions commenced immediately with combustion and even detonation. The added danger of handling anhydrous HF, did not help the development of fluorine chemistry for a number of years. Most potential workers thought at that time that elemental fluorine was too dangerous and of little practical use, an opinion still held today by some researchers.¹⁶² However, the desire to investigate the possibility that elemental fluorine could be a useful reagent, must have been a great challenge, and in fact, the outcome of that work led to the development of many fluorination technologies, which will be briefly described below.

1.11.1 Liquid-Phase Fluorination Technology

Major advances concerning the use of liquid-phase fluorination were made during the early part of last century (~1920 to 1930's). The work performed by Fichter, Bockmüller, Bancroft, Humiston, and Bigelow, showed that fluorination, albeit poly/per-fluorination could be achieved in a much more controllable manner if the substrate is 1) diluted in relatively inert solvent, 2) fluorine is diluted with an inert gas, and 3) the reaction is performed at low temperature. These observations ultimately led to a process which is still used today, although the present emphasis is more related to the selective fluorination of organic compounds. However, improvements to the fluorination

conditions were required to accomplish this change, such as the use of Lewis acids or the use of acidic/ polar reaction mediums.^{65, 163}

Recently, several reports concerning the use of gas-liquid fluorination microreactors have been described. It was reported that higher conversions and yields were obtained through better control of the reaction conditions. These reports will be discussed in far more detail, later in this thesis.¹⁶⁴⁻¹⁷¹

The development of a liquid phase perfluorination process has also been discussed by Scherer.¹⁷² In this process, fluorination occurs at ambient temperature and under the influence of UV light, however, a partially fluorinated organic compound is required. The partially fluorinated compound is slowly added into a perfluorocarbon solvent, which has been saturated with elemental fluorine, UV radiation generates a high concentration of fluorine radicals, which inhibits the formation of oligomers. High yields of perfluorinated products have been obtained.

A similar fluorination process has been described by Lagow.⁶⁵ The substrate is slowly added to a rapidly stirred inert solvent, such as a chlorofluorocarbon or perfluorocarbon, simultaneously, a large excess of fluorine is also added into the reaction. Perfluorination may be achieved by increasing the concentration of fluorine radicals, which is accomplished by the addition of a highly reactive hydrocarbon. The hydrocarbon reacts spontaneously with fluorine, generating a high concentration of fluorine radicals.

1.11.2 Vapour-Phase Fluorination Technology

Vapour-phase fluorination technology developed initially in the 1930's, allowed the perfluorination of a range of compounds to be performed under much more control.⁵¹ Fredenhagen and Cadenbach originally developed vapour phase fluorination methodology, in which the fluorination of organic compounds was performed over copper, iron, silver or cerium packing agents. Higher yields of perfluorinated products were obtained, although, they were still relatively low. Further improvements were made by Bigelow, who modified the operation and design of the reactor.¹⁷³⁻¹⁷⁵ Additional work carried out by Musgrave found that the highest yields were obtained using gold plated copper packing.¹⁷⁶ The technique of vapour phase fluorination was further

advanced by Bigelow, with the development of a jet fluorination reactor in which no metal packing was required. High yields of perfluorinated compounds were obtained using the jet fluorination reactor.^{177, 178}

1.11.3 LaMar Fluorination Technology

Lagow and Margrave developed the LaMar perfluorination process,⁵⁶ which involves a reactor possessing several fluorination zones, each zone having progressively increased temperature and fluorine concentration. The organic compound is condensed at low temperature into a tube filled with copper packing. Highly diluted fluorine is then passed through the reactor, as the organic substrate becomes fluorinated, it becomes more volatile and evaporates into the next reaction zone until perfluorination is achieved. Unfortunately, the process takes several days and is a batch process. An example of the LaMar fluorination process is given in figure 1.40.¹⁷⁹

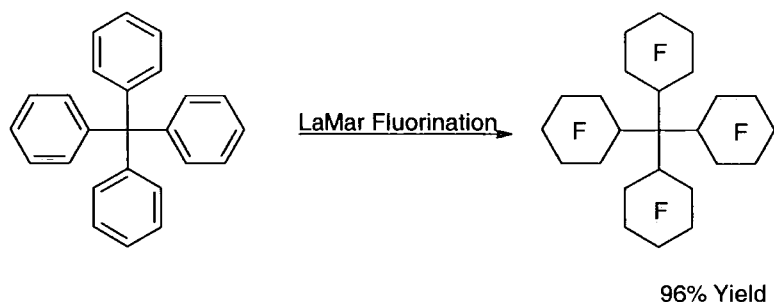

Fig 1.40

1.11.4 Aerosol Fluorination Technology

Adcock has achieved perfluorination using aerosol fluorination methodology.¹⁸⁰ Sodium fluoride is sublimed generating very small particles, onto which the organic compound is adsorbed. Using a carrier gas of helium, these coated particles are blown through a reactor that has increasing temperature and concentration of fluorine along its length. Finally, the particles now coated in fluorinated material, are passed through a UV finishing stage, which ensures that little or no hydrogen remains giving high yields of fluorinated products. The role of the sodium fluoride in the process is thought to be that

of a heat-sink. A further benefit to this process is that it is a continuous process. An example of aerosol perfluorination is shown in figure 1.41.¹⁵⁶

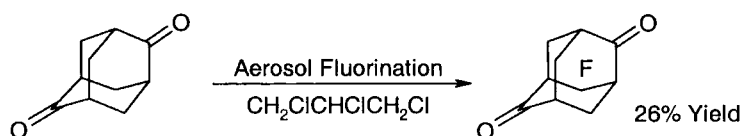

Fig 1.41

1.5 Chapter 1.0 Summary

Organofluorine compounds have been found to be extremely useful compounds and materials; however, they do not occur naturally and hence they must be prepared by a variety of synthetic methods. As a result, many fluorination technologies have been developed, which enables elemental fluorine to be used as a reagent in their synthesis. Be that as it may, while numerous elemental fluorination perfluorination technologies are known, there are still at present relatively few are concerned with the use of elemental fluorine for selective fluorination.

Chapter 2.0: The Direct Fluorination of N-Heterocycles

2.1 Introduction

2.1.1 General Introduction

Prior to this current work, the synthesis of fluorinated quinolines has been accomplished by a number of routes, namely by the:

- i) Use of N-F, O-F, and XeF₂ electrophilic fluorinating agents^{23, 181-183}
- ii) Use of the Balz-Schiemann reaction^{184-186 187, 188}
- iii) Use of the halogen exchange (Halex) reaction¹⁸⁹⁻¹⁹²
- iv) Use of functionalised pre-fluorinated benzenes, which are then subject to cyclisation, for example, the Skraup quinoline synthesis^{185, 186, 193}

There are a number of disadvantages with the aforementioned routes, for example, with the possible exception of (i), all synthetic methodologies require multistep procedures; moreover none of the classes of reagents mentioned in (i) can be made without involving the use of elemental fluorine.

We were therefore interested in exploring the use of elemental fluorine for the preparation of fluoro-quinolines and fluoro-isoquinolines, the results of which we will describe in this chapter.

Before the current work is discussed, literature concerning the preparation of fluorinated quinoline and isoquinoline derivatives will be reviewed in section 2.2.

2.1.2 Electrophilic Attack on Quinoline/ Isoquinoline

Electrophilic halogenation of quinoline (1) or isoquinoline (44) is complicated by uncertainties relating to the mechanism. The predicted positional reactivity for the conjugate acid of quinoline (1) is $8 > 5 > 6 > 7$, and is consistent with the observed products obtained from electrophilic substitution, in the presence of Brønstead or Lewis acids.¹⁹⁴⁻¹⁹⁶

If electrophilic substitution in sulfuric acid is considered, the quinoline heterocyclic ring acquires a positive charge via protonation of the ring nitrogen, and therefore electrophilic attack on the heterocyclic ring is disfavoured.

Electrophilic attack at C-5 (or C-8) on the conjugate acid would give rise to a Wheland intermediate in which two canonical forms are possible without perturbing the pyridinium system, as shown in scheme 2.1. On the other hand, electrophilic attack at C-6 (or C-7) results in only one canonical form, as depicted in scheme 2.2. One can predict that electrophilic attack at the 5- or 8-positions results in greater stability of the intermediate species than for the 6- and 7-positions. However, to predict the relative reactivity between the 5-/8- and 6-/7- positions, an additional approach is required in conjunction with the aforementioned discussion.

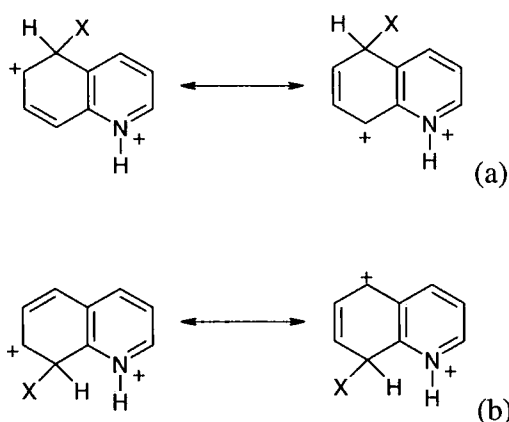

Scheme 2.1: (a) Electrophilic attack at C-5; (b) electrophilic attack at C-8

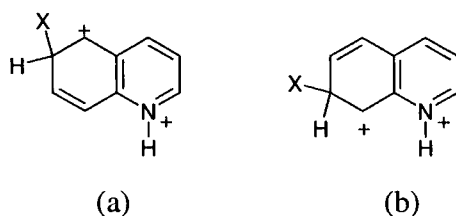

Scheme 2.2: (a) Electrophilic attack at C-6; (b) electrophilic attack at C-7

Consideration of the charge delocalisation in C-5 and C-8 Wheland intermediates reveals that electrophilic attack at C-8 is favoured over attack at C-5 (See Scheme 2.3). Attack at C-5 would result in an additional positive charge at the already positive

nitrogen, whereas in C-8 attack this would not occur. Similar arguments can be used to explain the fact that electrophilic attack at C-6 is favoured over attack at C-7 (See Scheme 2.4). It is worth noting that neither approach solely on its own can predict the overall relative reactivity

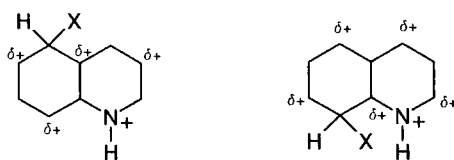

Scheme 2.3

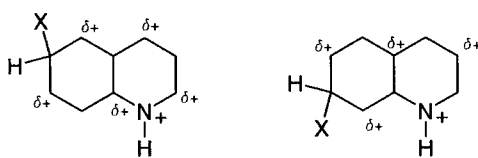

Scheme 2.4

Experimentally, the yields of 5- and 8- derivatives are similar in distribution and one rationalisation for this similarity may be derived from the fact that substitution at the 8-position requires an unfavourable close approach by the attacking electrophile to the adjacent positively charged nitrogen, which may severely hinder the process.¹⁹⁴⁻¹⁹⁶ Furthermore, rate constants for hydrogen exchange and nitration upon the conjugate acid have showed such wide variation that it has been suggested that no unique order of susceptibility to electrophilic attack and that no single reactivity index can be used as a measure of electrophilic reactivity towards quinoline.¹⁹⁶

Electrophilic halogenation of quinoline under neutral conditions appears to be in the order $3 > 6 > 8$, however this is not expected and after the ring nitrogen, which is the most reactive centre towards electrophiles, the positional reactivity is predicted to be $5 > 8 = 6 > 3$. The explanation for this difference in reactivity, is that halogenation under neutral conditions results in the initial reversible formation of a 1,2-addition product (1,4-addition is also possible), which subsequently gives rise to substitution at the 3-, 6-, and

8-positions. This mechanism takes account of the fact that the 3-, 6-, and 8-positions can all conjugate with a lone pair on the ring nitrogen, as shown in scheme 2.5.

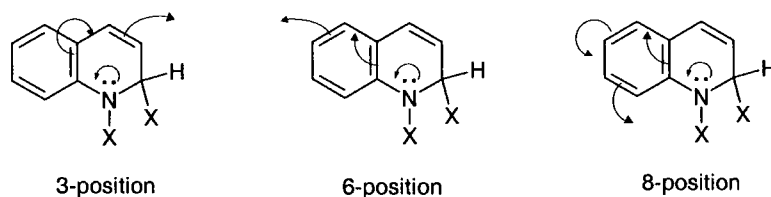

Scheme 2.5

Predicted positional reactivity for the conjugate acid of isoquinoline (44) using similar arguments to quinoline is $5 > 8 > 7 > 6$, and is consistent with the observed products obtained from electrophilic substitution, in the presence of Brønsted or Lewis acids (See Schemes 2.6 to 2.9).^{194, 197} Interestingly, the relative reactivity's of the 6- and 7- positions in isoquinoline (44) are reversed, however this change can be predicted from delocalisation considerations.

It has been found that the positional reactivity of isoquinoline (44) under neutral conditions is $4 > 7 = 5 > 8$ and can be explained in a similar manner to quinoline.

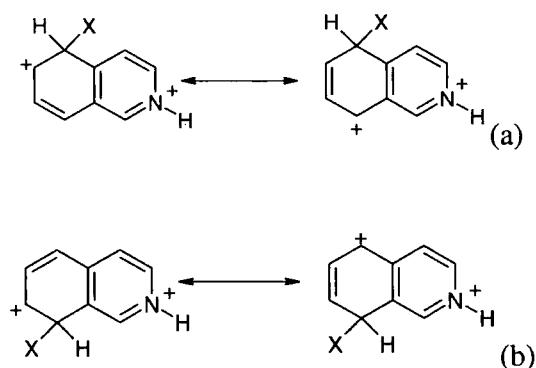

Scheme 2.6: (a) Electrophilic attack at C-5; (b) electrophilic attack at C-8

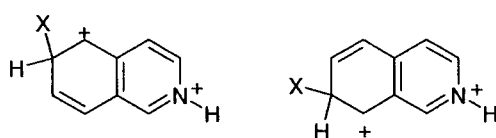

Scheme 2.7: (a) Electrophilic attack at C-6; (b) electrophilic attack at C-7

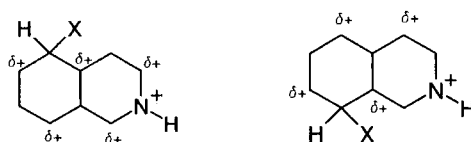

Scheme 2.8

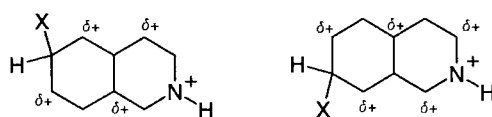

Scheme 2.9

2.2 Methods for Preparing Fluorinated Quinolines/ Isoquinolines

2.2.1 Electrophilic Fluorination

Several accounts describing the electrophilic fluorination of substituted quinolines involving replacement of hydrogen by fluorine have been reported, and these are shown in figure 2.1. Rozen has successfully used acetyl hypofluorite to fluorinate 6-methoxyquinoline (17) at the 5-position to give (18),¹⁸¹ whilst trifluoromethyl hypofluorite has been used by Gershon to prepare 5,7-difluoro-8-hydroxyquinoline from 5-fluoro-8-hydroxyquinoline.¹⁸² O'Neill has recently described the successful fluorination of 6-methoxy-8-nitroquinoline (23) at the 5-position by using N-fluorobenzenesulfonimide (NFSI) to give (24),²³ and xenon difluoride has been used by Anand to prepare 5-fluoro-8-hydroxyquinoline from 8-hydroxyquinoline.¹⁸³ However, all of the above reagents require elemental fluorine for their preparation.

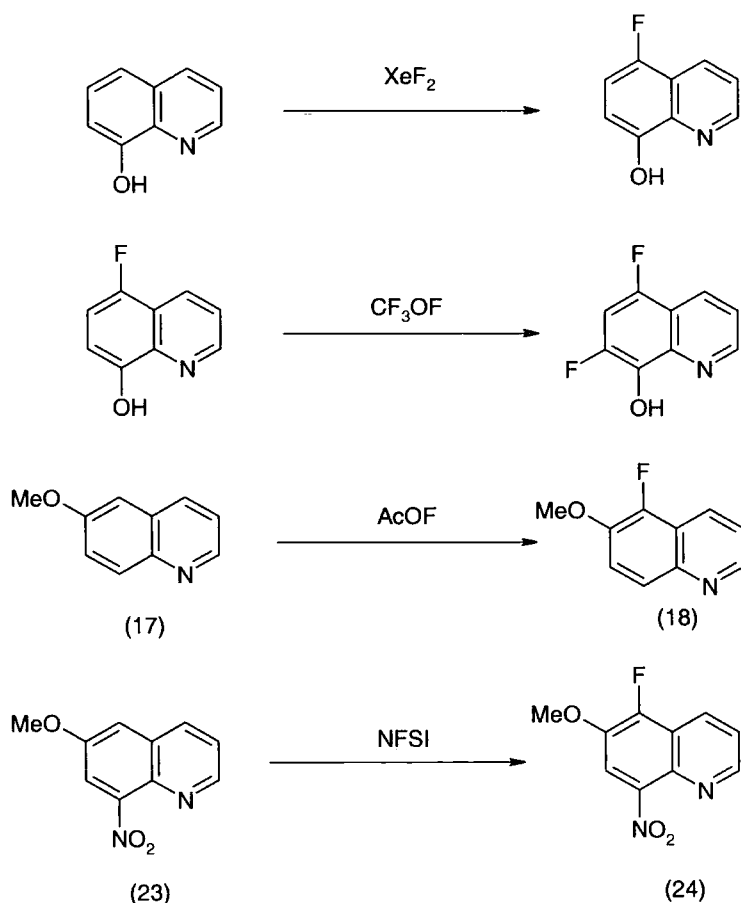

Fig 2.1

2.2.2 Balz-Schiemann Reaction

Many fluorinated quinolines and isoquinolines have been prepared by the Balz-Schiemann reaction, as depicted in figure 2.2.184-186 187, 188, 198 The Balz-Schiemann reaction involves the diazotisation of an aromatic amine in the presence of HBF_4 or other fluorine containing salts. Thermal decomposition of the diazo salt produces the desired fluorine containing aromatic compound in a wide range of yields. This methodology is particularly useful for the exclusive generation of a single fluorinated product, although a major disadvantage is that the required aminoquinoline/isoquinoline must first be synthesised.

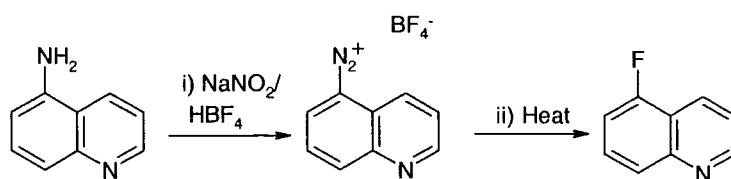

Fig 2.2

2.2.3 Halex Reaction

The halex reaction is a useful method for the introduction of fluorine into pre-halogenated quinoline/ isoquinoline compounds, an example is shown in figure 2.3.¹⁸⁹⁻¹⁹² A pre-chlorinated quinoline derivative is heated in the presence of potassium fluoride. Nucleophilic displacement of the chlorine by fluorine gives rise to fluorinated quinolines/ isoquinolines. The halex reaction is found to be useful for the preparation perfluorinated compounds, however this process may also be used in the preparation of selectively fluorinated products. That being so, a disadvantage is that a chlorinated precursor is required as starting material.

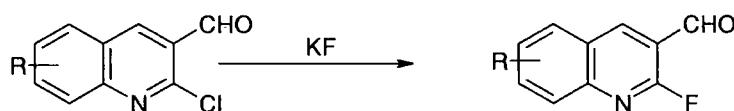

Fig 2.3

2.2.4 Skraup Synthesis and Related Methodology¹⁹⁹

Many cyclisation methods related to the synthesis of quinoline and isoquinoline heterocycles are known. Consequently, this thesis will not describe all existing methods, but instead the reader is directed to any good recent heterocyclic textbook. A few reactions will be described to briefly highlight the general art of heterocyclic synthesis.

2.2.4.1 Skraup Quinoline Synthesis

The Skraup quinoline synthesis, as depicted in figure 2.4, involves heating a mixture of a substituted aniline with glycerol and sulfuric acid. Sulfuric acid acts as the dehydrating agent for glycerol, which results in the *in-situ* formation of propenal. The details of the actual mechanism are not currently known, but it is speculated that after conjugate

addition, the intermediate is cyclised, oxidised, and dehydrated to give the respective substituted quinoline.

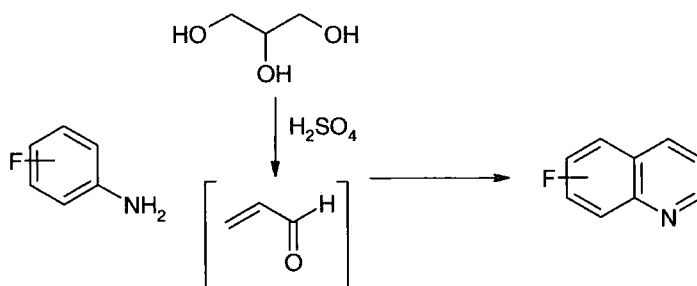

Fig 2.4

2.2.4.2 Doebner-von Miller Quinoline Synthesis

The Doebner-von Miller quinoline synthesis shown in figure 2.5, is very similar to the Skraup synthesis, the slight difference being that α,β -unsaturated aldehydes are used instead of glycerol.

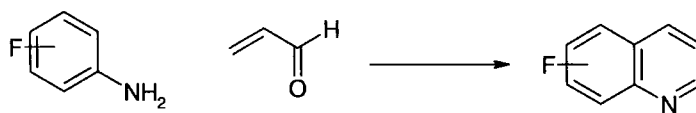

Fig 2.5

2.2.5 Previous Work Involving Elemental Fluorine

At the time of writing, there exists two reports, one by Kobayashi and another by Sato, concerning the direct fluorination of pyridine ring-fused heterocyclics.^{200, 201} Kobayashi, describes that using 10% F₂/Ar and DCM as the reaction solvent, isoquinoline (44) was recovered unchanged. Activation of isoquinoline with respect to fluorination, was achieved by conversion of isoquinoline into its 2-methyl-2-hydroisoquinolin-2-one. Fluorination of 2-methyl-2-hydroisoquinolin-2-one in DCM resulted in the formation of the 4-chloro derivative and not the desired fluoro analogue (See Fig 2.6). The formation of the chloro derivative was rationalised as a consequence of fluorine reacting initially with the solvent and liberating chlorine, which then reacted with

the substrate. Fluorination was finally achieved by the use of ethanoic acid as reaction solvent, and resulted in a 54% isolated yield of the 4-fluoro product.

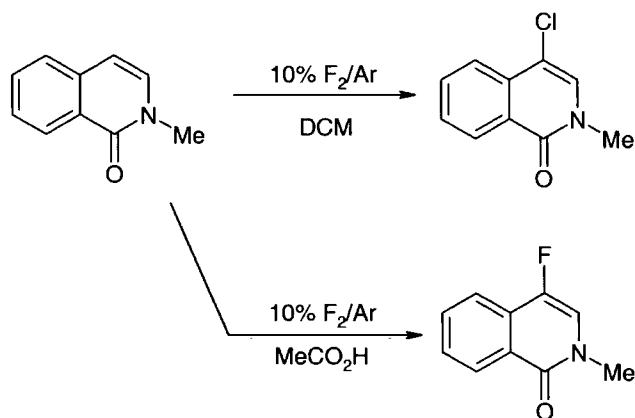

Fig 2.6

Sato has similarly reported the successful fluorination of 4-chloro-1-methyl-2-quinolone, using 5% F₂/N₂ in CCl₃F/CHCl₃/EtOH as reaction solvent, at low temperature. Fluorine was found to add across the 3- and 4- positions and the fluorine addition product could be isolated in 22% yield. However if triethylamine was subsequently used, the fluorine addition product eliminated HCl and the 3,4-difluoroanalogue was obtained in 32% yield.

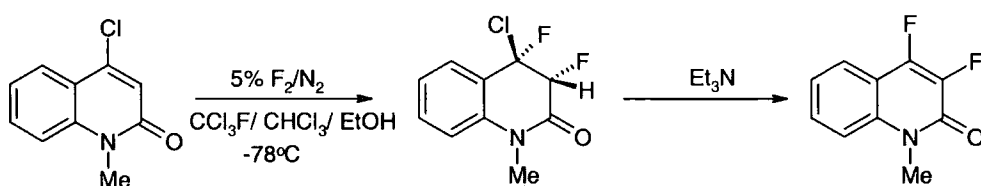

Fig 2.7

Chambers reports that fluorination of quinoline at the 2-position can be achieved if fluorination is performed in the presence of iodine, as described in figure 2.8. Iodine monofluoride, which is formed *in-situ* from the reaction between iodine and elemental fluorine, is thought to be the reactive species. The mechanism of fluorination involves the co-ordination of the iodonium ion to the nitrogen atom, followed by

nucleophilic attack by fluoride ion at C-2 and elimination of HI. The addition of base, such as triethylamine, consistently gave better results when compared to analogous reactions without base, presumably because the addition of base improved the efficiency of HI elimination. Conversions and yields were typically between 56-79% and 54-90% respectively. Moreover, the procedure can be used to introduce fluorine *ortho* to the heterocyclic ring nitrogen, if this position is un-substituted, in other pyridine ring containing compounds.

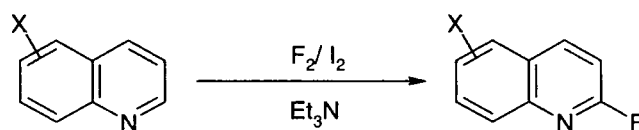

Fig 2.8

Chambers, Streckowski, and van der Puy, have all described that quinoline derivatives can be alkoxyated in moderate yields, if fluorine is passed through a solution of the quinoline derivative in the presence of ROH (where R = H, alkyl, phenyl), as described in figure 2.9.²⁰⁵⁻²⁰⁷ However, in some cases, small amounts of the corresponding 2-fluorinated derivatives were also observed. Also, the formation of 2-acetylquinolines directly from quinoline has been reported by Rozen via the generation of acetyl hypofluorite.²⁰⁸ Formation of these 2-substituted derivatives presumably occurs by the initial formation of a ring nitrogen N-F intermediate, followed by nucleophilic attack by the solvent at C-2, or as in the case of acetyl hypofluorite, ethanoate ion. Elimination of HF would then give rise to the 2-substituted derivatives. The small amounts of 2-fluoro derivatives could conceivably be formed by nucleophilic attack of the N-F intermediate by fluoride ion followed by elimination of HF, which would give rise to the formation of the 2-fluoro derivatives.²⁰⁹

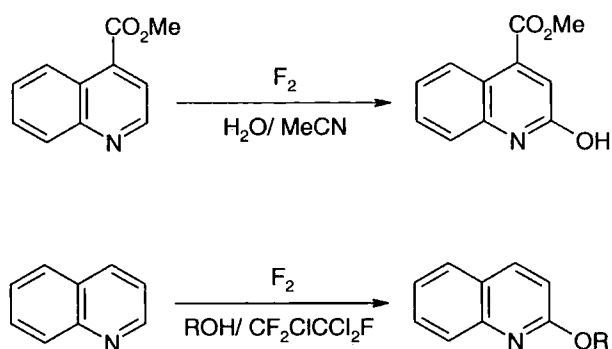

Fig 2.9

2.3 Direct Fluorination of N-Heteroaromatics

2.3.1 Quinoline (1)

2.3.1.1 Solvent Survey

As discussed in chapter 1, section 1.8.2, high permittivity/ acidic reaction media, namely, acetonitrile, methanoic acid, and sulfuric acid, have been shown to be excellent media for promoting direct electrophilic fluorination.⁶⁵ We reasoned therefore, that these types of media should also promote the selective direct fluorination of quinoline substrates. Hence, we have performed a solvent survey to establish the optimum reaction medium.

Acetonitrile - The direct fluorination of (1) in acetonitrile gave significant quantities of dark intractable material. Analysis of the crude product by ¹⁹F NMR, showed the presence of many fluorinated products, which could not be identified. Repeating the experiment using less fluorine resulted in similar results. Consequently, it was concluded that the direct fluorination of (1) in acetonitrile, i.e. under neutral conditions, is unselective, and as a result was not pursued further.

Methanoic acid - The fluorination of (1) in methanoic acid resulted in a crude product which was shown by ¹⁹F NMR analysis to consist of many fluorinated products, however four major products were present (See Fig 2.10). Three of these products were later identified as 5-fluoro (2), 8-fluoro (4), and 5,8-difluoroquinoline (5) by comparison to previously reported electrophilic halogenation experiments,²¹⁰⁻²¹³ and literature ¹H, ¹³C, and ¹⁹F NMR data (See Fig 2.10).^{185, 214, 215}

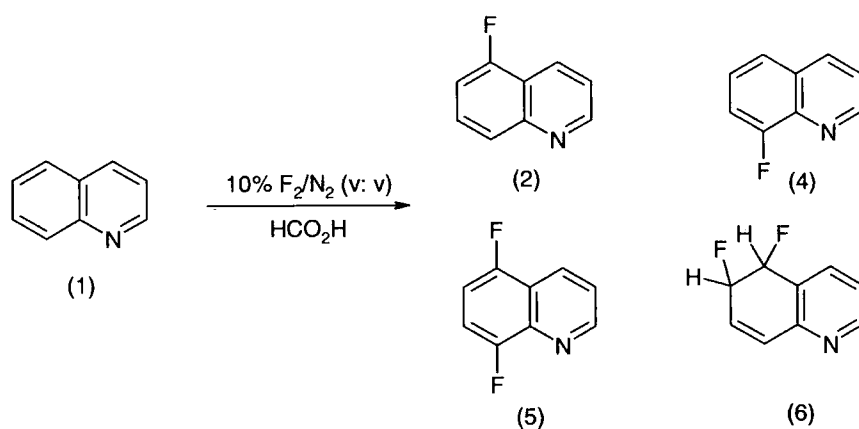

Fig 2.10: (2): (4): (5): (6) ratio was observed to be 3.8: 2.7: 1.0: 3.2

Accompanying (2), (4), and (5) was the addition product (6), observed in the ¹⁹F NMR at around -200 ppm. Addition products could be identified by their distinctive ²J_{HF} couplings (~50Hz), which is characteristic of CHF groups.

The fluorine addition product was characterised as 5,6-difluoro-5,6-dihydroquinoline (6); the assignment of (6) was made on the basis that two ¹⁹F NMR signals were observed, one at 201.1ppm and another at 201.7ppm with coupling constants of 49.6Hz and 48.1Hz respectively, confirming that there are two CHF groups in (6). The ¹³C NMR was found to be particularly useful, since it is known that the C-4α carbon in quinoline is found upfield from its C-8α counterpart,²¹⁶ which is consistent with the C-8α carbon being adjacent the ring nitrogen. Using ¹H-¹³C HETCOR and ¹H-¹H COSY NMR, the C-4α carbon was assigned at 115.2ppm and was found to be a doublet, where the coupling constant was measured at 20.5Hz, which is consistent with a ²J_{CF} coupling. Substitution at the C-4 position was excluded by ¹H and ¹H-¹H COSY NMR, and hence one CHF group is found at C-5. Moreover, the position of the second fluorine may be obtained from the fact that the two CHF groups, both had ¹J_{CF} and ²J_{CF} couplings (¹J_{CF} 180.5Hz, ¹J_{CF} 185.9Hz and ²J_{CF} 17.8Hz, ²J_{CF} 18.2Hz respectively), which indicates that the two fluorines are adjacent to each other. Therefore, as one CHF group is located at the 5-position, then by deduction the other CHF group must be located at the 6-position.

The formation of significant intractable material was also observed in the reaction, to the extent of approximately 25% by weight. The ¹⁹F NMR ratio of the four

major products (2): (4): (5): (6) was observed to be 3.8: 2.7: 1.0: 3.2. It was concluded that methanoic acid is a substantially better fluorination medium than acetonitrile.

Sulfuric acid – It has been reported previously, that the halogenation of (1) with elemental halogen (X_2) (where $X = \text{Br}, \text{Cl}, \text{I}$) occurs readily in sulfuric acid (See Fig 2.11), and that the 5-, 8-, and 5,8-dihalogenated quinolines were the major products.²¹⁰⁻²¹³ Further work, describes that bromination in the presence of aluminium trichloride, which complexes to the quinoline nitrogen, resulted in the formation of the 5-, 8-bromo, and the 5,8-dibromo derivatives. Chlorination under analogous conditions behaves in a similar manner.¹⁹⁷ As discussed in section 2.1.2, electrophilic halogenation of quinoline in sulfuric acid, is consistent with electrophilic attack occurring on the conjugate acid and not on the free base.

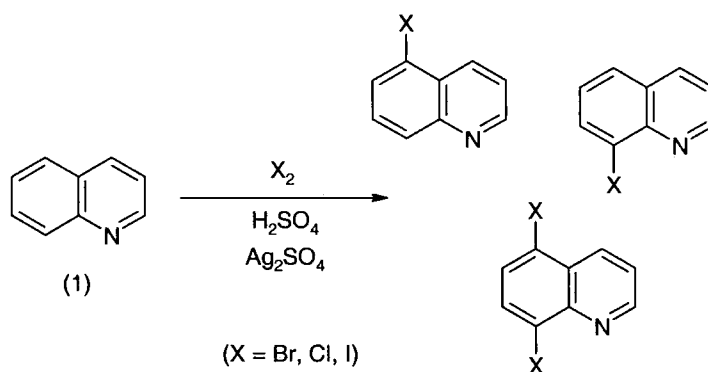

Fig 2.11

In our work it was found that the fluorination of (1) in sulfuric acid took place with the formation of minimal intractable material and resulted in the formation of (2), (3), (4), and (5) as the only major products, (See Fig 2.12) as identified previously. Furthermore, no fluorine addition products were observed in the ^{19}F NMR spectra of the crude product.

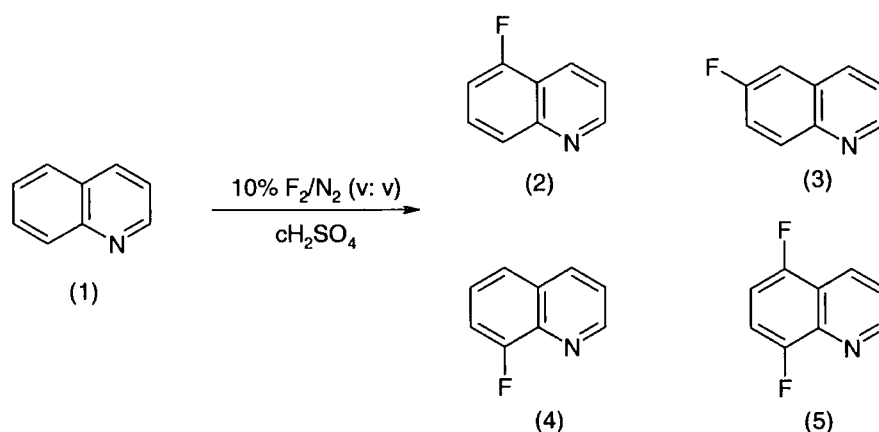

Fig 2.12

2.3.1.2 Solvent Survey Conclusion

The solvent survey has established that sulfuric acid is the solvent of choice for performing direct electrophilic fluorination reactions, and as such, sulfuric acid or its derivatives i.e. oleum, were employed as reaction medium in all successive fluorination experiments. Furthermore, we find that the product distribution is consistent with electrophilic fluorination occurring on the conjugate acid as discussed in section 2.1.2.

2.3.1.3 Quinoline (1) in Sulfuric Acid

Once the preferred reaction solvent was established (See section 2.3.1.1), we have investigated a range of further reaction conditions, the results of which are presented in table 2.1.

Fluorination of (1) at 1°C with six equivalents of fluorine, gave four major products with a total yield of 91% having a conversion of 42%. The four major products were found to be (2), (3), (4), and (5). Fluorination performed at a higher temperature (18°C) increased the conversion slightly to 51%, but had an undesirable effect on the selectivity by reducing the overall yield to 75%. Moreover, the yields of (2) and (4) decreased, while the yield of (5) increased, but unknown polyfluorinated derivatives could also be detected in the ¹⁹F NMR spectra of the crude product. When the reaction was performed at 1°C using twelve equivalents of fluorine, the conversion was found to increase to 67%, although this was accompanied by a decrease in the overall yield (81%).

The effect on product distribution by increasing the amount of fluorine used was similar to the one observed by increasing the reaction temperature.

In order to allow the work-up to be performed in a more convenient manner, the volume of acid was decreased. However, in order to maintain the volume of reaction medium, which is partly used as a heat transfer medium, an inert bulking agent was used, namely perfluoroperhydrophenthrene (PP11). Fluorination performed in a 1:9 sulfuric acid/ PP11 reaction solvent gave a conversion of 34% and a total yield of 94%. A 3% yield of (6) was also unexpectedly obtained, although the formation of (6) could be due to the fact that (1) dissolved in the PP11 layer, where fluorination by addition took place as compared to the work described by Sato.²⁰¹ However, increasing the amount of sulfuric acid used to a 2:8 sulfuric acid/ PP11 reaction medium, completely inhibited the formation of (6), presumably by the protonation of any free base present. Unfortunately, this was achieved at the expense of conversion, which was found to decrease (22%). One possible reason for the observed lower conversions in these two mixed solvent reactions may stem from the fact that sulfuric acid is insoluble in PP11, and the resultant stirred mixture would obviously be an emulsion, which could hinder the fluorination of (1).

Table 2.1: The direct fluorination of quinoline (1) in sulfuric acid and sulfuric acid/ PP11 mediums

Reaction Medium	Temp. (°C)	Equivalents of Fluorine	Conv ^a %	Yield of (2)	% Yield of (3)	% Yield of (4)	% Yield of (5)	% Yield of (6)
cH ₂ SO ₄	1	6	42	44	11	23	13	0
cH ₂ SO ₄	18	6	51	27	8	16	24	0
cH ₂ SO ₄	1	12	67	27	8	14	32	0
10%								
cH ₂ SO ₄ :	1	7.4	35	43	14	26	8	3
PP11								
20%								
cH ₂ SO ₄ :	1	7.4	22	48	11	27	8	0
PP11								

(Conversions and yields were determined from the ¹⁹F NMR by comparison to an internal reference)

(PP11 = perfluoroperhydrophenanthrene)

2.3.1.4 Concluding remarks

We have found that the fluorination of (1) in sulfuric acid gave four major fluorine containing products in good overall yield. Use of a large excess of fluorine resulted in the preferential formation of (5), while the use of a moderate excess resulted in the preferential formation of (2) and (4). The use of higher temperatures was also found to lead to the preferential formation of (5). On the other hand, the reaction represents a poor method for the selective formation of fluorinated products, since a mixture of products was obtained, however, we envisage that substituted quinoline derivatives will be more selective and this will be discussed in the next section.

2.3.2 Heterocyclic and/or Carbocyclic Ring Substituted Quinolines

Having established that the electrophilic fluorination of (1) is possible, we decided to investigate further the affects of substituents on the regioselectivity of fluorination. As such, we divided the task at hand into heterocyclic ring substituted and carbocyclic ring substituted quinolines. Later in light of the work described below, we included quinolines where substituents are present on both rings into the latter discussion.

2.3.2.1 2-Chloroquinoline (7)

We could find no prior reports detailing the halogenation of (7) in the literature. Nevertheless, we carried out the direct fluorination of (7) in an oleum/PP11 mixed solvent, and not sulfuric acid, so as to prevent potential problems associated with the nucleophilic displacement of the 2-chlorine under the reaction conditions. The fluorination of (7) with twelve equivalents of fluorine was found to give a 68% conversion and four major products, which we later characterised as (8), (9), (10), and (11) (See Fig 2.13 and Table 2.2). Identification was made by comparison of the crude ^{19}F NMR data to that obtained from the fluorination of (1), because both sets of ^{19}F NMR data were found to be very similar.

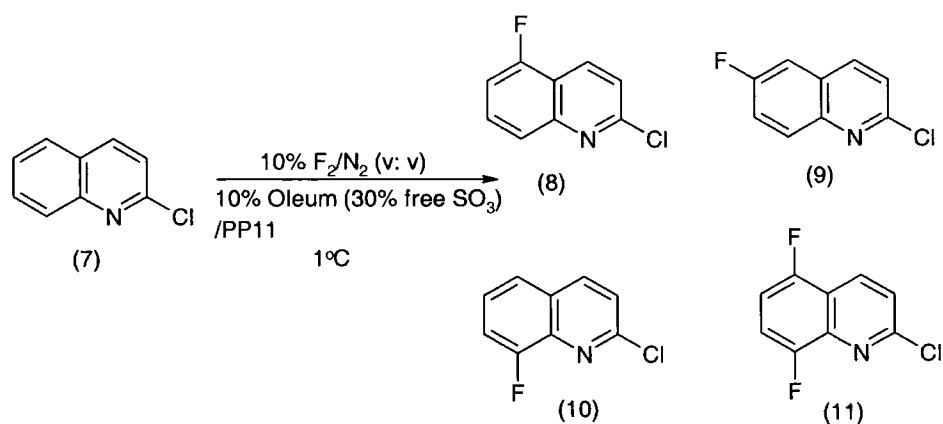

Fig 2.13

Table 2.2: The direct fluorination of 2-chloroquinoline (7) in oleum/PP11

% Conversion	% Yield of (8)	% Yield of (9)	% Yield of (10)	% Yield of (11)
68	25	11	16	21

We observed that the 2-chloro substituent did not increase the selectivity of fluorination at any position, and in fact product distribution between the four major fluoro derivatives is similar to the fluorination of (1) with twelve equivalents of fluorine. However, the yield of (11) was significantly lower than the yield of (5) under similar conditions.

2.3.2.2 4-Methylquinoline (12)

We are not aware of any prior reports in the literature detailing the halogenation of (12). Nonetheless, fluorination of (12) with 3.25 equivalents of fluorine resulted in a conversion of 26% and the formation of four major products, which we later identified as (13), (14), (15), and (16) (See Fig 2.14 and Table 2.3), by comparison of the crude ¹⁹F NMR data with those obtained from the fluorination of (1) and (7). It is worth pointing out, that the chemical shift of the fluorine at the 6- and 8-positions was relatively unperturbed by the introduction of the 4-methyl group. However, the 5-fluorine in

compounds (13) and (16) was shifted downfield by approximately 11ppm in both cases, due to the presence of the 4-methyl group.

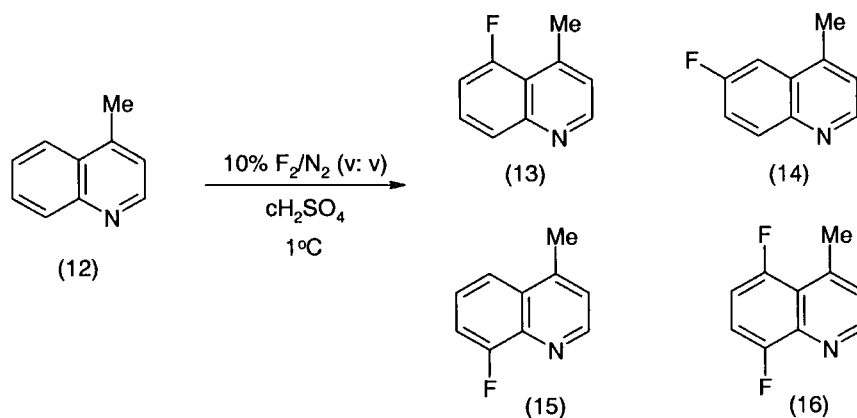

Fig 2.14

Table 2.3: The direct fluorination of 4-methylquinoline (12) in sulfuric acid

% Conversion	% Yield of (13)	% Yield of (14)	% Yield of (15)	% Yield of (16)
26	48	14	23	6

We found that the 4-methyl group gave no increase in the selectivity of fluorination at any position, and in fact, product distribution between the four major fluoro derivatives is similar to the fluorination of (1) with six equivalents of fluorine.

2.3.2.3 Concluding Remarks Concerning Heterocyclic Ring Substituted Quinolines

We have demonstrated that the presence of a substituent in the heterocyclic ring does not influence the regioselectivity for fluorination at any position, at least not to any great extent. Overall, we conclude that the direct fluorination of substituted derivatives where the substituent is present at the 2- or 4- position, will not provide an efficient route to selectively fluorinated quinolines. It follows that in the light of our present work, 3-substituted quinolines will most probably behave in an analogous manner. However,

since the majority of electrophilic substitution occurs in the carbocyclic ring, the use of substituted derivatives where the substituent is present in this ring, may improve the regioselectivity of fluorination. We present our findings in the next section.

2.3.3 Carbocyclic Ring and Carbocyclic-Heterocyclic ring Substituted Quinolines

2.3.3.1 6-Methoxyquinoline (17)

The direct fluorination of (17) using 3.25 equivalents of fluorine occurred readily in sulfuric acid and conversion was found to be 71%. Fluorination took place efficiently with no intractable material being observed.

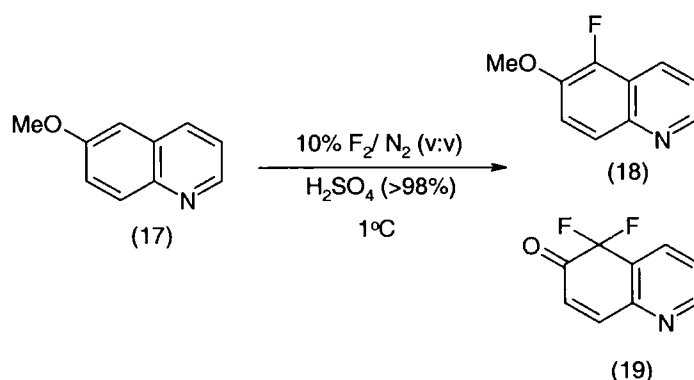

Fig 2.15

The ¹⁹F NMR spectra showed the presence of only two products in the crude product, which were later characterised as (18) and (19) (See Fig 2.15 and Table 2.4), by comparison to literature ¹H and ¹⁹F NMR data¹⁸¹. The ¹⁹F NMR spectra of (19) was similar to that obtained from the naphthalene derivative.^{217, 218} Furthermore, the ¹³C NMR data showed that the C-4 α carbon of (18) and (19) was a doublet (13.7Hz) and a triplet (24.3Hz) respectively. The carbon-fluorine coupling constant measured in each case was indicative of a ²J_{CF} coupling, moreover, the ¹H and ¹H-¹H COSY NMR spectra ruled out substitution at C-4 position. The coupling constants at the C-8 α carbon for (18) and (19) were found to be doublet (7.2Hz) and a triplet (6.1Hz) respectively, which are characteristic of ³J_{CF} couplings. Hence it was concluded that electrophilic fluorination took place at C-5, furthermore the X-ray crystal structure of (19) gave conclusive

evidence and this is presented in figure 2.16. The proposed mechanism for the transformation of (18) into (19) is presented in figure 2.17.

Complementary work has been described by Elderfield concerning the direct chlorination of (17), where chlorination was achieved in ethanoic acid and gave the chlorinated derivative of (18).²¹⁹ Interestingly, this report did not mention the formation of the dichloro derivative of (19), although a later report details its synthesis by passing chlorine through a solution containing the hydrogen chloride salt of (17).²²⁰

Fluorination (17) was repeated in methanoic acid to ascertain whether sulfuric acid was crucial to the reaction when substrates activated towards electrophilic substitution are used. The reaction was subsequently found not to take place efficiently, and whilst conversion was quantitative, a substantially lower yield of (18) was obtained, as well as a slightly lower yield of (19) (See table 2.4). Many other uncharacterised products were also observed in the ¹⁹F NMR spectra.

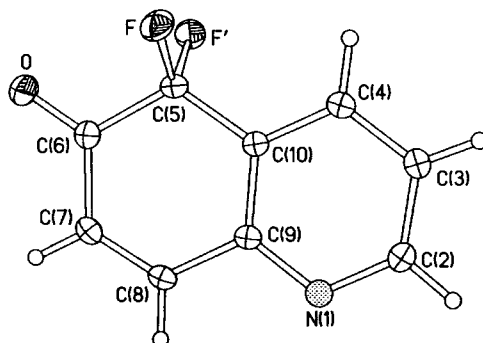

Fig 2.16: X-ray crystal structure of (19) depicted using 50% displacement ellipsoids

Table 2.4: Direct Fluorination of 6-methoxyquinoline (17) in sulfuric acid and methanoic acid

Reaction Medium	% Conversion	% Yield of (18)	% Yield of (19)
cH_2SO_4	71	74	26
HCO_2H	100	27	18

The preparation of (18) has also been described by Rozen who used acetyl hypofluorite to fluorinate (17), as described in section 2.1.¹⁸¹ (Acetyl hypofluorite was generated by bubbling fluorine through a suspension of sodium ethanoate in a 10:1 CCl₃F/ AcOH solvent at low temperature, prior to the addition of (17).) The yield of (18) reported by this method is 75%, therefore fluorination of (17) by elemental fluorine appears to be in a way analogous to acetyl hypofluorite. Consequently, it could be argued that there is no further need invoke the use of acetyl hypofluorite to achieve the aforementioned transformation.

As discussed above, we conclude that the introduction of the 6-methoxy group has had a significant influence on the regioselectivity of electrophilic fluorination, that is it promotes electrophilic attack by fluorine at the 5-position, as no other products, other than the difluoro derivative (19) were detected.

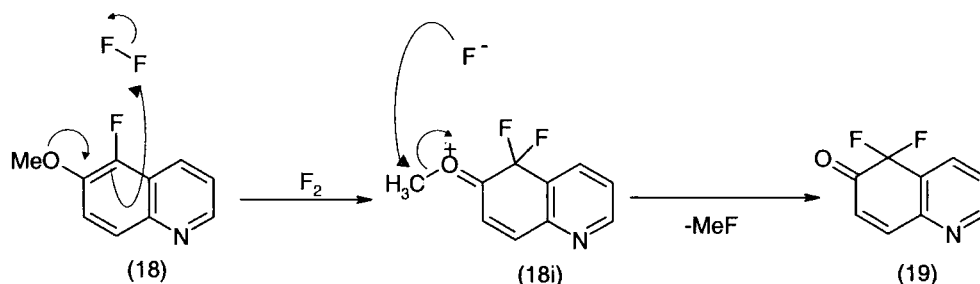

Fig 2.17

2.3.3.2 2-Chloro-6-methoxyquinoline-3-carbaldehyde (20)

Preparation of the bromo and chloro derivatives of (21) has been discussed by Cziáky, via the direct halogenation of (20) with elemental bromine and chlorine. Although the iodo derivative could not be prepared by direct iodination under analogous conditions,²²¹ moreover the formation of dihalogeno adducts similar to (22) were not reported.

We initially performed the direct fluorination of (20) with five equivalents of fluorine in a 10% sulfuric acid/ PP11 solvent mixture, due to doubts concerning the stability of the 2-chloro substituent under solely sulfuric acid reaction conditions, and during aqueous work-up. These concerns were subsequently found to be unfounded and

the 2-chloro group was found to be stable under normal reaction and work-up conditions. The ^{19}F NMR spectra of the crude product showed the presence of only two products, which were identified as (21) and (22) by comparing the ^{19}F NMR shifts to those of (18) and (19) respectively. Further evidence for the formation of (21) and (22) may be obtained by considering the ^{13}C NMR C-4 α carbon couplings as previously described. The C-4 α couplings for (21) and (22) were found to be a doublet (13.7Hz) and a triplet (25.1Hz) respectively, which are characteristic of a $^2\text{J}_{\text{CF}}$ coupling, moreover the ^1H and ^1H - ^1H COSY NMR spectra ruled out substitution at C-4 position. The corresponding C-8 α couplings were found to be a doublet (2.3Hz) and a triplet (5.9Hz), which are suggestive of $^3\text{J}_{\text{CF}}$ coupling. Hence, fluorination occurred at the 5-position. Additionally, the X-ray crystal structures of (21) and (22) were obtained and these are depicted in figures 2.19 and 2.20.

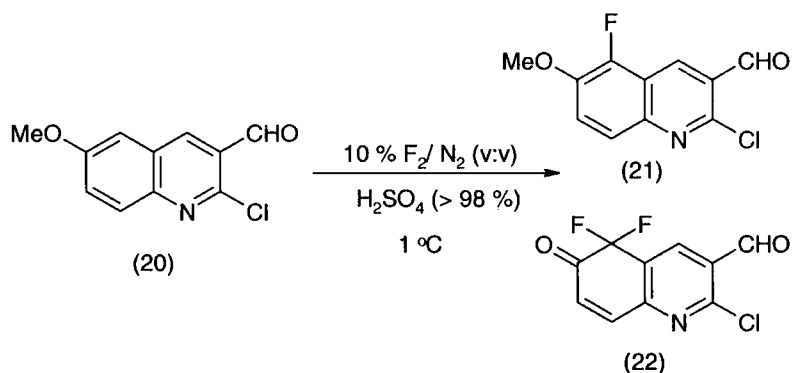

Fig 2.18

Unfortunately, fluorination in the mixed solvent system with five equivalents of fluorine gave a disappointing conversion (27%), although the yield of (21) was very high (97%) with only a trace (3%) of the difluoro adduct (22) being formed (See Fig 2.18 and Table 2.5). The formation of intractable material was not observed, nor was the formation of carboxylic acid derivatives derived from the reaction of fluorine with the aldehyde group, via an acetyl fluoride intermediate.

On the other hand, fluorination performed in sulfuric acid with six equivalents of fluorine, gave a much higher conversion (66%), although while the yield of (21) was found to decrease (73%), the yield of (22) increased accordingly (27%). Furthermore, the

use of twelve equivalents of fluorine resulted in (22) being the major product (84%), while (21) was found to be the minor component (16%), conversion increased slightly to 79%. Fluorination reactions performed with the use of fifteen equivalents of fluorine, were performed on a preparative scale and gave a quantitative yield of (22), which required no further purification. The formation of (22) from (21) is thought to occur via a similar mechanism to that shown in figure 2.17.

Table 2.5: Direct fluorination of 2-chloro-6-methoxyquinoline-3-carbaldehyde (20)

Reaction Medium	Equivalents of F ₂	% Conversion	% Yield of (21)	% Yield of (22)
15 % cH ₂ SO ₄ / 85 % PP11	5	27	97	3
cH ₂ SO ₄	6	66	73	27
cH ₂ SO ₄	12	79	16	84
cH ₂ SO ₄	15	100	0	100 (96) [§]
cH ₂ SO ₄	15	100	0	100 (89) ^ζ

[§] Isolated yield from a 5g scale reaction, ^ζ Isolated yield from a 10g scale reaction.

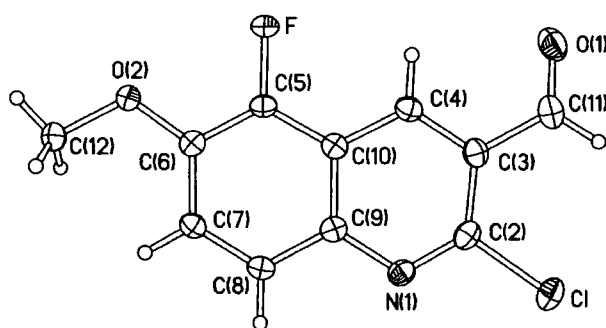

Fig 2.19: X-ray crystal structure of (21) depicted using 50% displacement ellipsoids

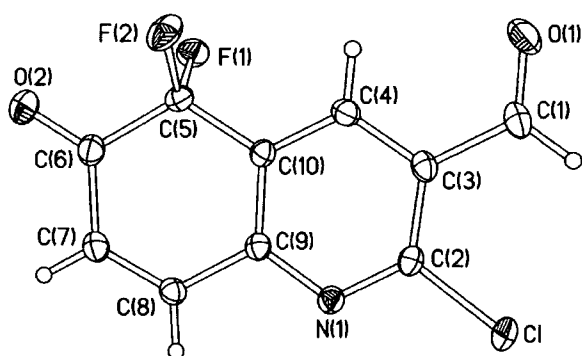

Fig 2.20: X-ray crystal structure of (22) depicted using 50% displacement ellipsoids

As discussed in section 2.3.3.1, the introduction of the 6-methoxy group allows the selective electrophilic fluorination at the 5-position. Moreover, we have found this to be true for the electrophilic fluorination of (20), which was found to give analogous regioselectivity. It may be said that the influence of the heterocyclic ring substituents, other than slightly reducing the reactivity of (20) towards fluorine, upon regioselectivity is negligible. This result is consistent with the findings discussed in section 2.3.2.3.

2.3.3.3 6-Methoxy-8-nitroquinoline (23)

There are several reports concerning the direct halogenation of (23). Direct chlorination has been achieved in ethanoic acid by Tatsuoka who found that the major product was the chlorinated derivative of (24).²²² Moreover the use of diluted chlorine was reported to give better yields, when compared to using neat chlorine. Bromination on the other hand, has been reported by several workers, namely Elderfield and Tatsuoka,²²²⁻²²⁴ to give the bromo derivative of (24).

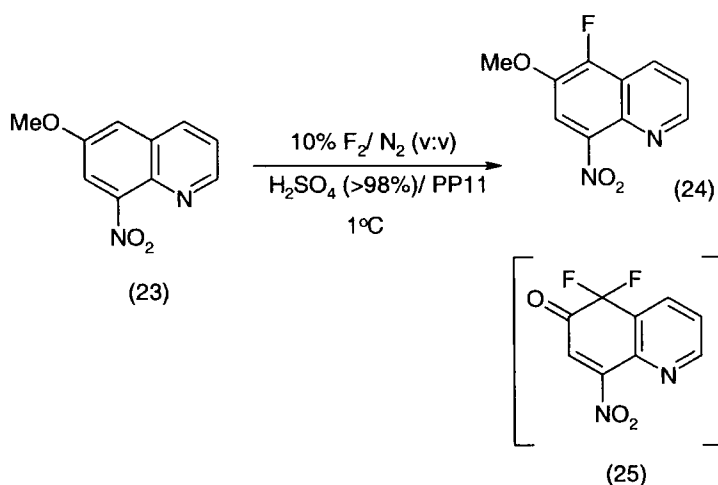

Fig 2.21

The direct fluorination of (23) has not been previously described prior to this work, but several other routes concerning the synthesis of (24) are known. The Skraup synthesis has been reported recently by O'Neill,^{23, 225} who obtained a 30% yield of (24), this yield was found to be significantly higher than the previous yields described by Elderfield, who reported a 5 and 9% yield.²¹⁹ Similarly, the Skraup synthesis of a related compound of (24), namely, the 4-methyl derivative, was also reported to occur in 25% yield. Further work by O'Neill^{23, 225} examined the use of the halox reaction and N-F electrophilic fluorinating agents. A 30% overall yield of (24) was obtained from the halox reaction, and a 38% yield of (24) was obtained by treatment of (23) with NFSI, as described in section 2.1.

We performed the direct fluorination of (23) by using eight equivalents of fluorine in a sulfuric acid medium, as a result conversion was found to be 56% (See Fig 2.21 and Table 2.6). However, the ¹⁹F NMR spectra of the crude product indicated that only one major product was isolated. The product was identified as (24) by comparison to the literature ¹H and ¹⁹F NMR data,²³ consideration of the C-4 α and C-8 α carbon-fluorine coupling constants was also indicative of (24) being the 5-fluoro derivative. Moreover, the X-ray crystal structure of (24) was obtained and is depicted in figure 2.22.

We would expect by analogy with (19) and (22) (discussed in sections 2.3.3.1 and 2.3.3.2.), that the respective gem-difluoro derivative (25) would be produced by a

mechanism analogous to the one presented in figure 2.17, however, it is believed that (25) is unstable with respect to nucleophilic attack by water, due to the presence of the 8-nitro group, and hence, would not be extracted from the aqueous media during work-up. On the other hand, this fact allowed the purification of (24) to be achieved relatively easily.

Table 2.6: Direct fluorination of 6-methoxy-8-nitroquinoline

Reaction Medium	Equivalents of F ₂	Crude Product		% Conversion	% Yield of (24)
		Isolated (g)			
cH ₂ SO ₄	8	0.38		56	>99
cH ₂ SO ₄ / PP11	4	0.97		22	100
cH ₂ SO ₄ / PP11	14	0.45		59	100
cH ₂ SO ₄ / PP11	23	0.11		-	-

Subsequent fluorination reactions were therefore performed using a mixed solvent system, as described previously, and with successive increases in the amount of fluorine used. The mass of isolated product obtained after aqueous work-up was found to decrease with increasing excess of fluorine, which is consistent with the formation of (25), as this product is not isolated upon work-up.

It can be seen therefore, by comparison to published methodology, that the direct fluorination of (23) results in a far higher yield of (24) when compared to any of the previously described synthetic routes to (24).

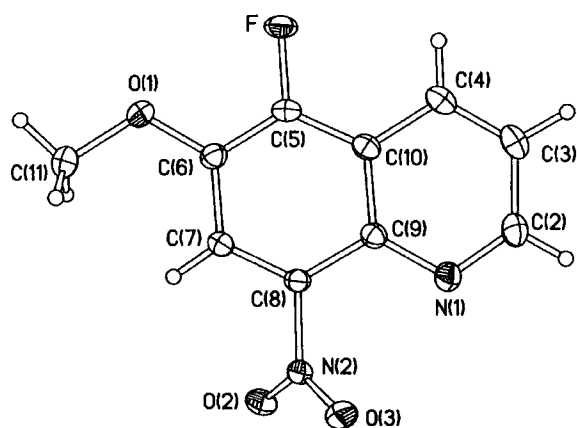

Fig 2.22: X-ray crystal structure of (24) depicted using 50% displacement ellipsoids

As discussed in sections 2.3.3.1 and 2.3.3.2, we have found that the introduction of the 6-methoxy group affects the exclusive formation of 5-fluoro products, namely (18), (21), and in this case (24). Moreover, it can be seen that the influence of the 8-nitro group on the regioselectivity, apart from reducing the overall reactivity of (23) towards electrophilic attack by fluorine, is also negligible. However, the deactivating influence of the nitro group is substantially larger than the effects of the substituent groups in (20).

2.3.3.4 6-Chloroquinoline (26)

We are not aware of any reports in the literature concerning the halogenation of (27). Nevertheless, when the direct fluorination of (26) was performed using twelve equivalents of fluorine, a 59% conversion was observed (See Fig 2.23 and Table 2.7). The ^{19}F NMR spectra showed the presence of two major products in the proportions of 79% and 5%. These were characterised as (27) and (28) respectively, which is consistent with the results obtained from the fluorination of (1).

The identification of (27) was made by examining the ^{13}C NMR data, where the C-4 α carbon was found to be a doublet (15.5Hz) having a coupling constant characteristic of a $^2\text{J}_{\text{CF}}$ coupling, moreover, the C-8 α carbon was a doublet (2.4Hz) where the coupling constant was indicative of a $^3\text{J}_{\text{CF}}$ coupling. The ^1H and ^1H - ^1H COSY NMR spectra also ruled out the possibility of fluorine being present at C-4, hence it was concluded that substitution took place at C-5. The difluoro derivative (28) was identified by comparison to the ^{19}F NMR spectra of (5) and (11), which had similar chemical shifts.

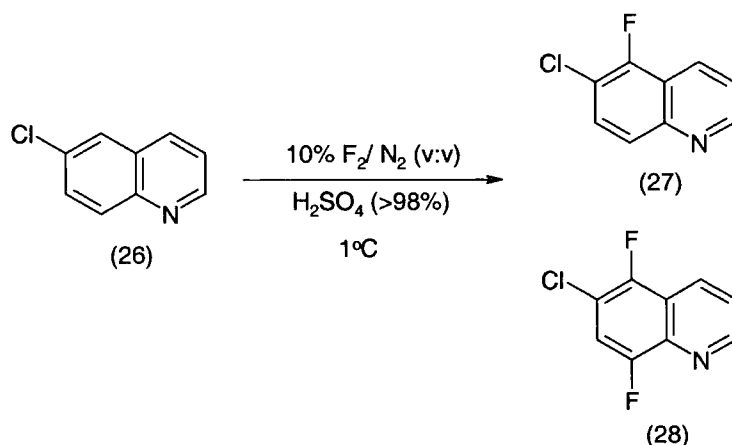

Fig 2.23

Table 2.7: Direct fluorination of 6-chloroquinoline

% Conversion	% Yield of (27)	% Yield of (28)
59	79	5

The selectivity for the 5- position was found to be enhanced by the presence of the 6-chloro substituent, but at the same time a minor effect is that the overall reactivity towards electrophilic attack is reduced, as evidenced by the slightly lower conversion compared to (1) under analogous conditions.

2.3.3.5 6-Methylquinoline (29)

Bromination of (29) by N-bromosuccinimide in sulfuric acid has been discussed by Tochilkin.²²⁶ Bromination occurred readily under the reaction conditions and the bromo derivative of (30) was obtained as the major product, along with the dibromo derivative of (31).

We performed the direct fluorination of (29) using 3.25 equivalents of fluorine, as a result conversion was determined to be 54%. The ¹⁹F NMR spectra showed that two major products were obtained in the proportions of 75% and 5%, which were later characterised as (30) and (31) respectively by comparison to previous experimental data

(See Fig 2.24 and Table 2.8). Identification of (30) was made by examining the carbon-fluorine coupling constants at the C-4 α and C-8 α carbons, the C-4 α carbon was found to be a doublet (14.8Hz) having a coupling constant characteristic of a $^2J_{CF}$ coupling, moreover, the C-8 α carbon was a doublet (2.7Hz) where the coupling constant was indicative of a $^3J_{CF}$ coupling. The 1H and 1H - 1H COSY NMR spectra also ruled out the possibility of fluorine being present at C-4, hence it follows that substitution took place at C-5.

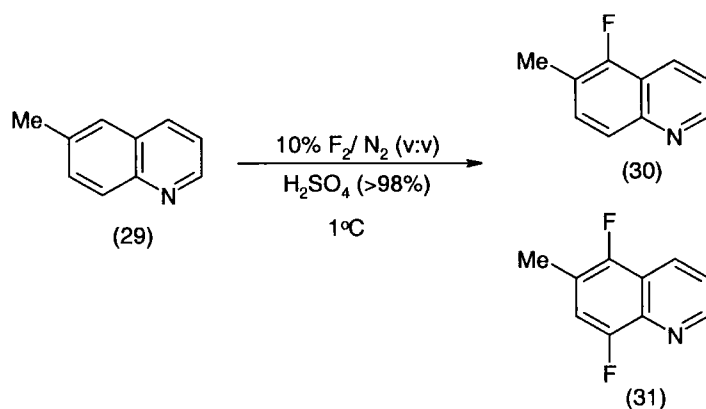

Fig 2.24

The structure of (31) was assigned by comparison of the ^{19}F NMR spectra to that obtained from (5) and (28). Further evidence may be derived from the C-4 α and C-8 α carbons in the ^{13}C NMR spectra, both of which were found to be doublets of doublets, where the $^2J_{CF}$ coupling constants were measured as 20.8Hz, 13.7Hz and the $^3J_{CF}$ coupling constants measured as 5.6Hz, 3.0Hz respectively. Thus, we concluded that fluorination had occurred at both the 5- and 8-positions.

The identification of (32), a very minor product in the ^{19}F NMR spectra, which is shown in figure 2.25, was also concluded. A quartet of doublets observed at -158.1 ppm (qd, $^3J_{HF}$ 21.8 $^3J_{HF}$ 8.3), is similar to the ^{19}F NMR data obtained from compounds (43) - 144.4 ppm (qd, $^3J_{HF}$ 20.3 $^3J_{HF}$ 5.6, F.₈) and (62) -158.6 ppm (qd, $^3J_{HF}$ 22.8 $^3J_{HF}$ 7.5, F.₆), which have been irrefutably identified by X-ray crystallography (See Figs 2.33 and 3.14). Moreover, the ^{19}F NMR data agrees with that of a similar geminal fluoro methyl compound described by Dmowski.²²⁷

Table 2.8: Fluorination of 6-methylquinoline

% Conversion	% Yield of (30)	% Yield of (31)
54	75	5

Repeating the experiment under analogous conditions but using twelve equivalents of fluorine, resulted in the formation of some intractable material and unidentified products in the ^{19}F NMR spectra. However, the presence of (30), (31), and (32) could be identified as minor components of the crude mixture.

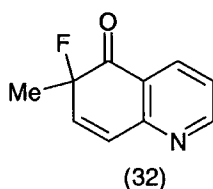

Fig 2.25

The 6-methyl group has been found to encourage electrophilic substitution at the 5-position. However, unlike the 6-methoxy derivatives (17), (20), and (23) described in sections 2.3.3.1 to 2.3.3.3 inclusive, where gem-difluoro products were obtained, (29) gave the difluoro product (31). By comparison of the conversions it may be said that (29) is less reactive than (17), but, is more reactive than (1), and this is what would be expected for an electrophilic process.

2.3.3.6 6-Nitroquinoline (33)

The bromination of (33) by N-bromosuccinimide in sulfuric acid, has been reported by Tochilkin,²²⁶ and the bromo derivative of (34) was obtained as the major product. However, bromination could only be achieved in moderate yield by using harsh conditions, which were 100% sulfuric acid at 60°C.

We found that the direct fluorination of (34) at 1°C with twelve equivalents of fluorine gave a conversion of 13%, although the reaction was very selective resulting in a high yield of (34) (86%) (See Fig 2.26 and Table 2.9).

Compound (34), was identified by comparing the carbon-fluorine coupling on the C-4 α and C-8 α carbons, observed in the ^{13}C NMR spectra. The C-8 α carbon was found to be a doublet with a coupling constant of 12.2Hz, whilst the C-4 α carbon was also a doublet, but with a coupling constant of 3.0Hz. These coupling constants are characteristic of $^2J_{\text{CF}}$ and $^3J_{\text{CF}}$ carbon-fluorine couplings, hence it follows that the fluorine is located at the 8-position. Furthermore, the X-ray crystal structure of (34) was obtained, which gave irrefutable proof for the formation of (34) and this is depicted in figure 2.27. It should be pointed out however, that trace impurities were also observed in the crystal and the possible structures of these are shown in figure 2.28. Information gathered from the X-ray crystal structure data suggests that in addition to the 8-fluorine, 7% of the hydrogen located at position C-3 was fluorine, and 5% of the hydrogen at C-5 was fluorine. This suggests the products 5,8-difluoro-, 3,8-difluoro-, 3,5-difluoro- and 3,5,8-difluoro-6-nitroquinoline could also have been present in the crystal, although the exact product(s) could not be determined.

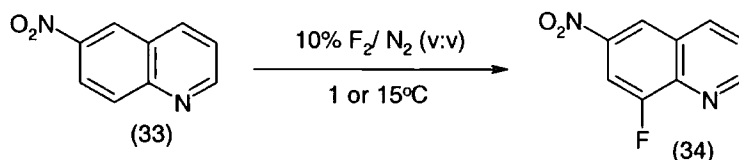

Fig 2.26

Repeating the reaction at 15°C with eighteen equivalents of fluorine, significantly increased the conversion, although the selectivity fell slightly. The use of a sulfuric acid/PP11 mixed solvent system at 15°C also improved the conversion slightly. The use of an oleum/PP11 system, proved to be the best system by far, but at the expense of a significant decrease in selectivity, as determined from the uncharacterised products present in the ^{19}F NMR spectra. Attempted fluorination in methanoic acid at 10°C resulted in the recovery of starting material.

Table 2.9: Direct fluorination of 6-nitroquinoline

Reaction Medium	Equivalents of F ₂	% Conversion	% Yield of (34)
cH ₂ SO ₄ ^ξ	12	13	86
cH ₂ SO ₄ ^γ	18	41	74
cH ₂ SO ₄ / PP11 ^γ	12	38	78
oleum/ PP11 ^γ	15	61	59

^ξ Reaction was performed at 0°C, ^γ Reaction was performed at 15°C.

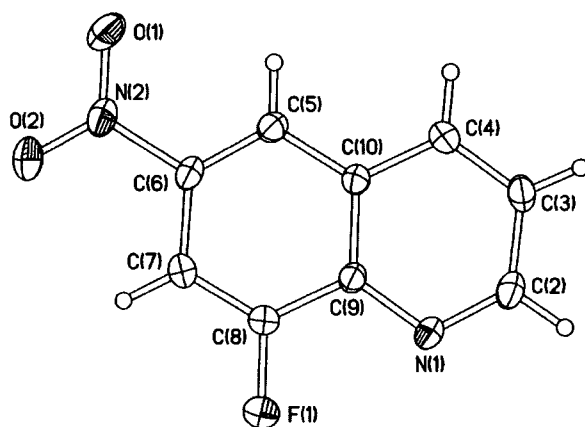

Fig 2.27: X-ray crystal structure of (34) depicted using 50% displacement ellipsoids

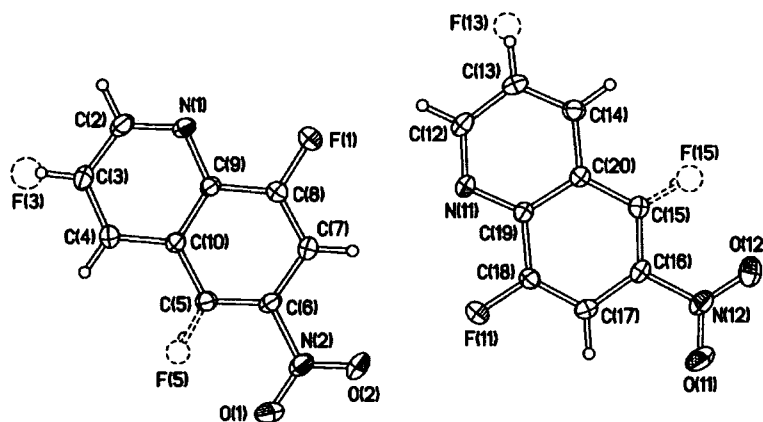

Fig 2.28: Impurities found in the X-ray crystal structure of (34), depicted using 50% displacement ellipsoids

We conclude that the effect of introducing the 6-nitro group is that electrophilic attack by fluorine is directed toward the 8-position. By comparison of the conversions, it may be said that the introduction of a strong electron withdrawing nitro group has deactivated the overall the reactivity of quinoline, which is consistent with an electrophilic process, and (34) can be considered to be less reactive than (1).

2.3.3.7 4,7-Dichloroquinoline (35)

We can find no reports in the literature concerning the halogenation of (35). Nonetheless, we found that the direct fluorination of (35) in sulfuric acid with six equivalents of fluorine resulted in a 19% conversion (See Fig 2.29 and Table 2.10). The ^{19}F NMR spectra showed the presence of two major products in the proportions of 76% and 4%, which were subsequently identified as (36) and (37) respectively.

Evidence for the formation of (36) was obtained from the ^{19}F NMR data, which showed a singlet, and therefore it can be concluded that the fluorine was not adjacent to hydrogen, where one would have expected a doublet. Moreover, the ^1H and ^1H - ^1H COSY NMR spectra showed chiefly that the H-2 and H-3 hydrogens and the H-5 and H-6 hydrogens were adjacent each to other, which is consistent with compound (36). Further more irrefutable proof was obtained from the X-ray crystal structure, which is depicted in figure 2.30, although it should be noted, that the presence of (37) was also detected in the crystal to the extent of ~17%. The ^{13}C NMR data was not found to be particularly informative in this case, due to shifting of the relative positions of the C-4 α and C-8 α carbons. Compound (37) was identified by comparison of the ^{19}F NMR data to that obtained from (5) and (16), which had similarities.

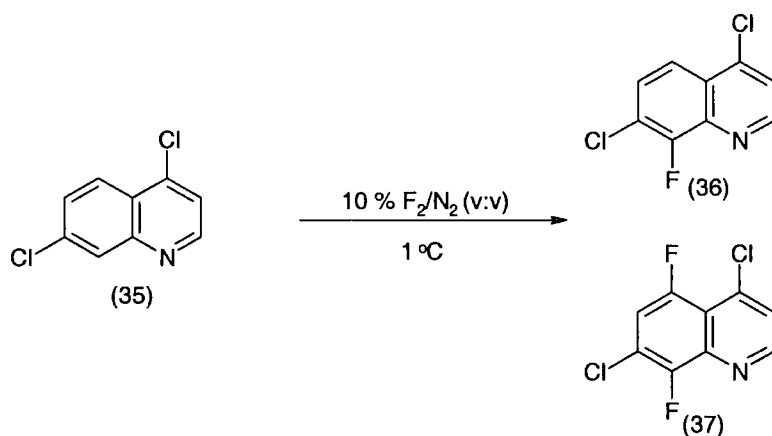

Fig 2.29

Table 2.10: Direct fluorination of 4,7-dichloroquinoline

Reaction Medium	Equivalents of F ₂	% Conversion	% Yield of (36)	% Yield of (37)
cH ₂ SO ₄	6	19	76	4
15% oleum/ PP11	12	62	46	11

The previous section (Section 2.3.3.6) showed that the highest conversion of (33) was obtained when an oleum/ PP11 mixture was used as reaction solvent. It follows then, that as a low conversion of (35) was observed in sulfuric acid, the oleum/ PP11 mixture should also be employed here also. Consequently, the reaction was performed in the this reaction medium, with twelve equivalents of fluorine, whereby the conversion was found to improve. However, the selectivity for (36) fell significantly and several other unidentified products were present, as observed in the ¹⁹F NMR spectra.

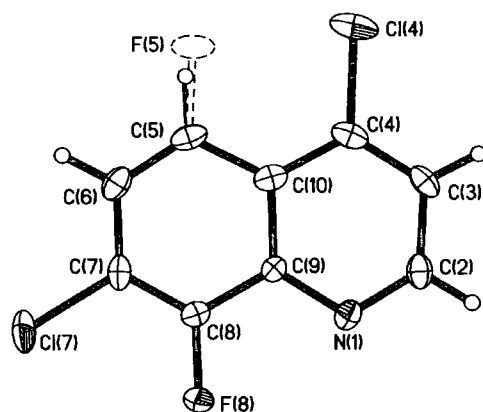

Fig 2.30: X-ray crystal structure of (36) containing some of (37), depicted using 50% displacement ellipsoids

We have found that by introducing the 7-chloro group, electrophilic attack by fluorine is directed toward the 8-position. The heterocyclic ring substituent, namely the 4-chlorine, was not found to influence the regioselectivity, which is consistent with the results obtained in sections 2.3.2.3 and 2.3.3.2.

2.3.3.8 2,7-Dimethylquinoline (38)

We can find no reports in the literature detailing the halogenation of (38). However, the bromination of 7-methylquinoline, a related compound to (38) has been achieved by using N-bromosuccinimide in sulfuric acid.²²⁶ Tochilkin describes that bromination gave the corresponding 8-bromo-7-methylquinoline derivative of (39), and a small amount of 5,8-dibromo-7-methylquinoline, a derivative of (40).

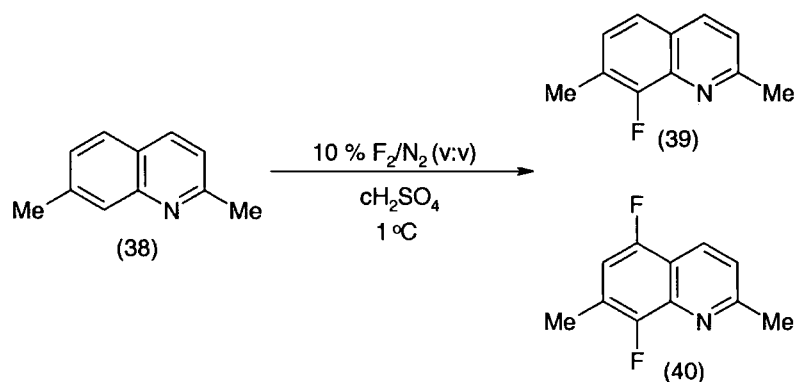

Fig 2.31

We found that the direct fluorination of (38) with 2.5 equivalents of fluorine gave a 40% conversion. The ^{19}F NMR spectra showed the presence of two major products in the proportions of 82% and 12%, which were subsequently identified as (39) and (40) respectively.

Identification of (39) was made by examining the ^{19}F NMR data, which showed the presence of a singlet, and hence indicated that the fluorine was not adjacent to hydrogen. Moreover the ^1H and ^1H - ^1H COSY NMR spectra also confirmed the position of the fluorine. Further evidence was derived from the carbon-fluorine coupling constants observed in the ^{13}C NMR data. The C-8 α carbon was found to be a doublet, with a measured coupling constant of 11.9Hz, the corresponding coupling constant of the C-4 α carbon was measured at 2.4Hz. Hence, the C-8 α carbon has $^2\text{J}_{\text{CF}}$ coupling and the C-4 α carbon $^3\text{J}_{\text{CF}}$ coupling. Based on this data, it may be concluded that fluorination took place the 8-position. Compound (40) was determined by comparison of the ^{19}F NMR data to that obtained from (5), (11), and (37). Furthermore, the ^{13}C NMR spectra showed that both the C-4 α and C-8 α carbons were doublets of doublets possessing $^2\text{J}_{\text{CF}}$ coupling constants of 18.6Hz, 13.7Hz, and $^3\text{J}_{\text{CF}}$ coupling constants of 2.3Hz, 3.8Hz respectively. Hence, fluorine is present at the 5- and 8-positions.

Repeating the reaction with a moderate and large excess of fluorine was found to increase the conversion of (38), however greater proportions of unidentifiable products were obtained, and in the latter case where ten equivalents were used, intractable material was also observed.

Table 2.11: Direct fluorination of 2,7-dimethylquinoline

Equivalents of F_2	% Conversion	% Yield of (39)	% Yield of (40)
2.5	40	82	12
5	51	61	15
10	62	28	23

We have found that the effect of introducing the 7-methyl group, is that electrophilic attack by fluorine is directed toward the 8-position. Moreover, the heterocyclic ring substituent was not found to influence the regioselectivity, at least not to any great extent, which is consistent with all previous results discussed in this thesis. By comparing conversions, (38) has been found to be more reactive than (35), which is what one would expect for an electrophilic process.

2.3.3.9 8-Methylquinoline (41)

The direct bromination, chlorination, and iodination of (41) have all been achieved in sulfuric acid at room temperature. Gracheva and Tochilkin report that the major product in all cases was found to be the 5-halogeno derivatives of (42).^{228, 229} Moreover, (42) was prepared from 5-amino-8-methylquinoline by the Balz-Schiemann reaction in 63% yield. Further work by Tochilkin, demonstrated bromination at the 5-position can be achieved by the use of N-bromosuccinimide in sulfuric acid.²²⁶

We found that the direct fluorination of (41) with 3.25 equivalents of fluorine gave a 40% conversion (See Fig 2.32 and Table 2.12). The ¹⁹F NMR spectra showed the presence of two major products in the proportions of 68% and 16%, which were subsequently identified as (42) and (43) respectively. Unfortunately, the literature report of (42) only describes the m.p. and b.p.,²²⁹ although the m.p. (21.0-21.5°C) is consistent with the fact that at room temperature, (42) was found to be a colourless oil. More convincing evidence may be obtained from the ¹³C NMR data, where the C-4 α carbon was found to be a doublet having a ²J_{CF} coupling constant of 16.3Hz, and the C-8 α carbon a doublet having a ³J_{CF} coupling constant of 4.5Hz. Hence it can be concluded that fluorination occurs at the 5-position. Compound (43) was identified by obtaining the X-ray crystal structure, which proves without doubt the aforementioned structure, moreover the NMR data is consistent with this structure. The ¹³C NMR data showed that the C-8 α carbon had a ²J_{CF} coupling constant of 16.3Hz, whilst the C-4 α carbon was found to have a ³J_{CF} coupling constant of 2.7Hz. Moreover, the 8-methyl group was found to have a ²J_{CF} coupling constant of 28.8Hz.

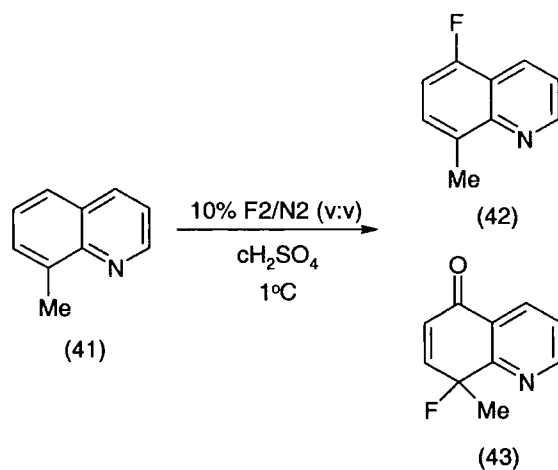

Fig 2.32

Increasing the amount of fluorine used in the reaction was found to increase the conversion of (41), however, the use of twelve equivalents of fluorine led to a higher proportion of unidentifiable products being obtained and intractable material. As can be seen from table 2.12, the use of a small excess of fluorine resulted mainly in the formation of (42). Whereas, the use of a large excess of fluorine mainly resulted in the formation of (43).

Table 2.12: Direct fluorination of 8-methylquinoline

Equivalents of F ₂	% Conversion	% Yield of (42)	% Yield of (43)
3.25	26	68	16
12	47	12	58

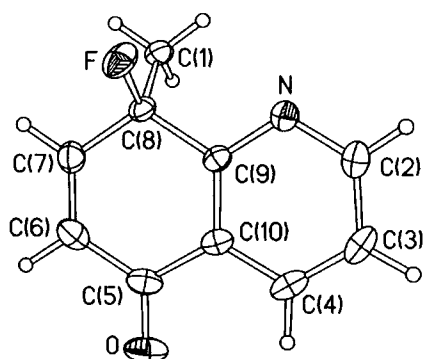

Fig 2.33: X-ray crystal structure of (43) depicted using 50% displacement ellipsoids

The formation of (43) was unexpected, and the exact mechanism is not currently known. However, two mechanisms have been proposed to account for the formation of (43) as shown in figures 2.34 and 2.35.

The first mechanism, which is shown in figure 2.34, involves the generation of a 5-hydroxy derivative (42i), either by electrophilic substitution mediated by the *in-situ* generation of HOF, or by nucleophilic substitution of the 5-fluorine. Fluorination of the intermediate (42i) could then potentially give (43).²³⁰ The residual water in the (>98%) sulfuric acid is assumed to be the source of the water.

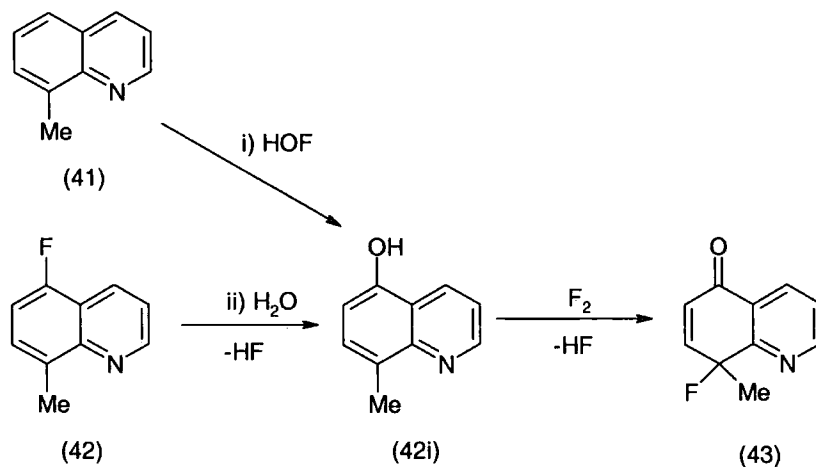

Fig 2.34

The second mechanism, which is shown in figure 2.35, involves initial electrophilic fluorination to give (42), followed by fluorine addition across the 7- and 8-positions to give the intermediate (42ii). Nucleophilic attack by water then occurs, which ultimately leads to the formation of (43), via the loss of two molecules of HF.

The first piece of information obtained about the mechanism is that (43) can be observed in the ^{19}F NMR spectra before work-up, although this does not rule out the possibility of nucleophilic attack upon the intermediate (42ii) in the work-up stage, as depicted in figure 2.35 if present.

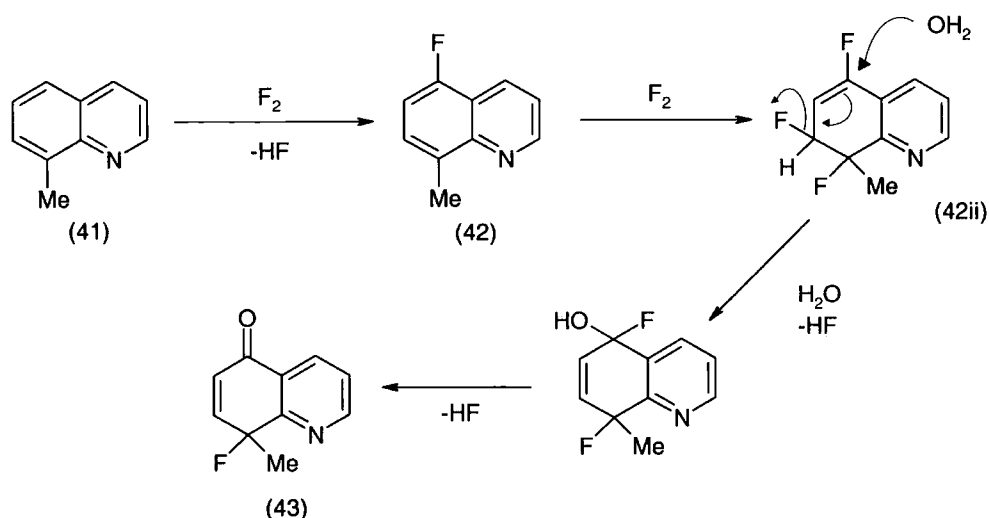
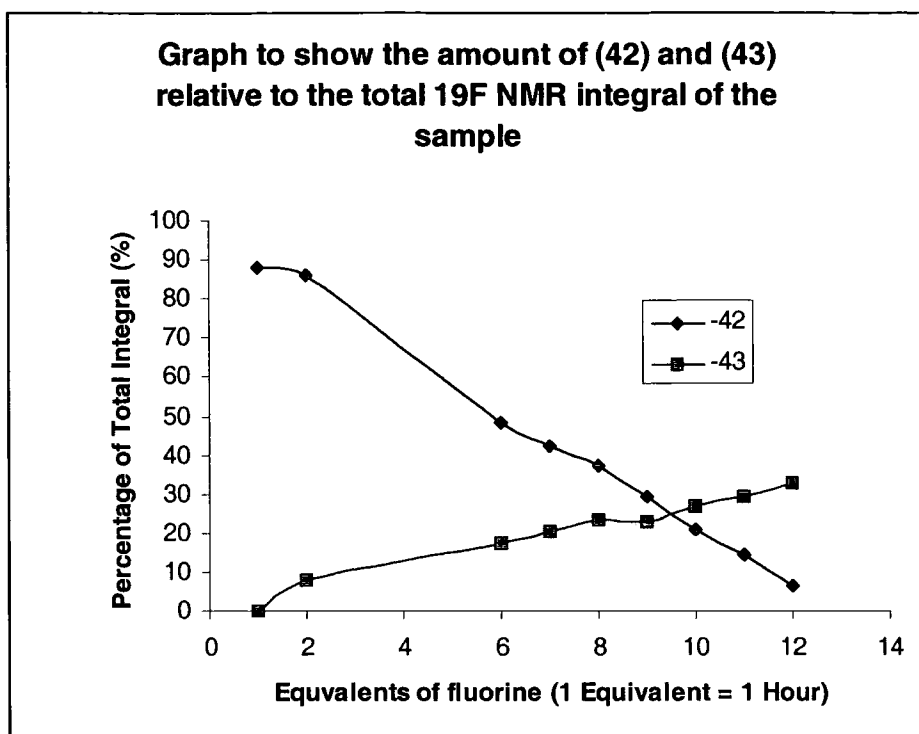

Fig 2.35

The second piece of information gathered was derived from the relative amounts of (42) and (43) present in the reaction mixture over a twelve-hour reaction, which is presented in graph 1; the relative amounts of (42) and (43) were measured by ^{19}F NMR periodically throughout the reaction. As can be seen from graph 1, the amount of (42) decreases with increasing amounts of fluorine, whilst the amount of (43) increases with increasing amounts of fluorine, although unfortunately, this information does not prove or disprove either mechanism but it suggests that (43) may be derived from (42).



Graph 1

A third piece of crucial information is derived from work that will be discussed in chapter 3, section 2.3.2.1. It has been found that the fluorination of (57) gave a minor product, which was determined by X-ray crystallography to be unequivocally (59) (See Fig 3.14). It was subsequently found that the direct fluorination of (57) in 10% water/90% sulfuric acid (v:v) medium, did not increase the yield of (59).

Further evidence can be derived from the facts that the attempted replacement of the 5-fluorine in (42) under nucleophilic conditions, and the attempted replacement of the 5-fluorine in (58) under acidic conditions, was not observed.

Consequently, as a result of these observation, mechanism (i) depicted in figure 2.34, can be ruled out. The reasons for this are that if HOF were generated *in-situ*, then the yield of the respective hydroxy intermediate would increase, and hence the yield of (59) would also be expected to increase, by the use of the aforementioned reaction medium, and this clearly did not occur. Mechanism (ii), also depicted in figure 2.34, which involves nucleophilic displacement of the 5-fluorine can also be ruled out by similar arguments. Moreover, the hydroxy intermediates would be expected to be more

reactive toward electrophilic attack, than the parent compound, and so the possibility that hydroxy compounds are produced and then undergo slow electrophilic substitution is unlikely.

It follows then that the most likely mechanism, is the second mechanism, which is depicted in figure 2.35. The reason for this assumption is that increasing the amount of water would not be expected to increase the formation of (43), since the amount of (42ii) present, depends on the rate of fluorine addition across the 7- and 8- positions. Unfortunately, the existence of the intermediate (42ii) could not be made conclusively due to the numerous other peaks observed in the ^{19}F NMR spectra.

We have shown that the effect of introducing the 8-methyl group is that the regioselectivity for electrophilic attack by fluorine is increased at the 5-position. Furthermore, we have evidence to suggest that (42) undergoes a further reaction with fluorine by addition ultimately giving rise to (43).

2.3.3.10 Concluding Remarks

We have demonstrated that the direct fluorination of quinoline derivatives with elemental fluorine can be achieved, in most cases efficiently, using concentrated sulfuric acid as a reaction medium. Moreover, we have shown that heterocyclic ring substituted quinolines do not influence, at least to any great extent, the regioselectivity of electrophilic substitution. Furthermore, we have found that high regioselectivities can be obtained if carbocyclic ring substituted quinolines are used. Reaction products are consistent with electrophilic fluorination occurring on the conjugate acid as discussed in section 2.1.2. In the large majority of products identified, product distribution mirrors other halogenation work published in the literature. We conclude that in principle, direct fluorination methodology opens up a new route to selectively fluorinated quinoline compounds, and offers a route to novel fluorinated compounds difficult to synthesise by any other means.

2.3.4 Isoquinoline (44)

2.3.4.1 Solvent Survey

As discussed in chapter 1, section 1.8.2, high permittivity/ acidic reaction media, namely, acetonitrile, methanoic acid, and sulfuric acid, have been shown to be excellent media for

promoting direct electrophilic fluorination.⁶⁵ Consequently in this chapter, sections 2.3.1 to 2.3.3, we discussed the fluorination of substituted quinolines, and it was concluded that sulfuric acid was the solvent of choice for performing selective direct fluorination. In the light of these results, we reason, that these types of media may also promote the selective direct fluorination of isoquinoline substrates. Hence, we performed a solvent survey to establish the optimum reaction medium.

Acetonitrile - The direct fluorination of (44) in acetonitrile gave significant quantities of dark intractable material. Analysis of the crude product by ¹⁹F NMR, showed the presence of many fluorinated products which could not be identified. Consequently, it was concluded that the direct fluorination of (44) in acetonitrile was unselective and thus was not pursued further.

Sulfuric acid - The bromination of (44) in the presence of excess aluminium tribromide has been described by Gordon,¹⁹⁷ to give 5-bromo, 8-bromo, and 5,8-dibromo derivatives of (45), (47), (48) respectively.

We found that the fluorination of (44) in sulfuric acid took place with the formation of minimal intractable material and resulted in the formation of (45), (46), (47), and (48) as the only major products (See Fig 2.36). Importantly, no fluorinated addition products were detected in the ¹⁹F NMR of the crude product. Fluorinated products were identified by comparison to literature data^{185, 215, 231} and to previous halogenation work.¹⁹⁷

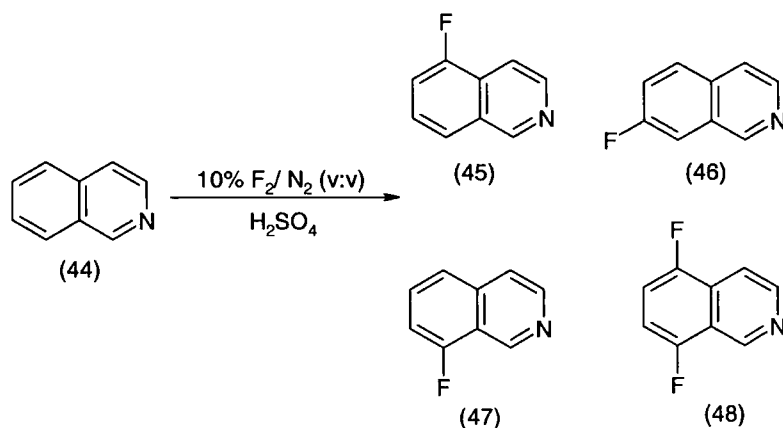

Fig 2.36

Products (45) and (47) were identified by deduction. The ^{19}F NMR data for (45) has been reported as -123.9ppm in the literature.²¹⁵ However, the ^{19}F NMR spectra of the crude product showed the presence of two peaks in this region with similar chemical shifts, at -123.4ppm and -123.6ppm. As a result, (45) could not be identified conclusively from the literature data alone. Fortunately, the compound responsible for the peak at -123.4 in the ^{19}F NMR was isolated, which allowed further analysis by ^{13}C NMR. It is known that in the ^{13}C NMR spectra of (44), the C-4 α carbon is downfield from its C-8 α counterpart.²¹⁶ The ^{13}C NMR data revealed that the C-4 α carbon was a doublet with a coupling constant of 3.8Hz, while the C-8 α carbon was found to be a doublet with a coupling constant of 15.4Hz. Therefore, it was concluded that the C-8 α carbon showed $^2\text{J}_{\text{CF}}$ coupling, whilst the C-4 α carbon showed $^3\text{J}_{\text{CF}}$ coupling, hence it follows that fluorine was present at the 8-position, i.e. (47). By deduction the ^{19}F NMR peak at -123.6 was concluded to be (45).

Compound (48) was identified by the following rationalisation. The ^{19}F NMR spectra showed only one peak at -128.2ppm. However, the mass spectrum in EI mode indicated a molecular ion of 165, which corresponds to an empirical formula of $\text{C}_9\text{H}_5\text{F}_2\text{N}$. The ^1H NMR showed the presence of only five proton signals, moreover the ^{13}C NMR spectra showed the presence of two $^1\text{J}_{\text{CF}}$ coupling constants, indicating the presence of two C-F carbons. Furthermore, the C-4 α and C-8 α carbons are both doublets of doublets with coupling constants attributable to $^2\text{J}_{\text{CF}}$ and $^3\text{J}_{\text{CF}}$ coupling, namely 20.1Hz, 17.4Hz and 4.8Hz, 5.3Hz respectively. As a result of the aforementioned data, structure (48) was concluded. The 5- and 8- fluorines present in (48) have coincidental ^{19}F NMR resonances, moreover this has also been observed in the ^{19}F NMR of a structurally related compound, namely 1,4-difluoronaphthalene where the ^{19}F NMR resonance is quoted as -127.9ppm.²³² It is worth pointing out, that a previous report describes a similar observation for (5),²³¹ however, in the light of this current work we concluded that the ^{19}F NMR chemical shift reported at -128.8ppm is in fact that of (48) and not that of (5).

Compound (47) was identified by comparison to previous halogenation results, and by comparison to the ^{19}F NMR data for 7-fluoroquinoline, which is similar.^{197, 215}

2.3.4.2 Solvent Survey Conclusion

The solvent survey has established that sulfuric acid is the solvent of choice for performing direct electrophilic fluorination reactions, and as such, sulfuric acid has been employed as reaction medium in all successive fluorination experiments. The product distribution is consistent with electrophilic fluorination occurring on the conjugate acid.

2.3.4.3 Isoquinoline (44) in Sulfuric Acid

As the preferred reaction solvent has been established (See section 2.3.4.1), We have investigated the effect of increasing the amount of fluorine used in the reaction, the results of which are presented in table 2.13.

Table 2.13: Direct fluorination of isoquinoline

Equivalents of F_2	Mass of (44) used (g)	% Conversion	% Yield of (45) and (47) (~1:1 ratio)	% Yield of (48)
2	2.5	12	80	8
6	2.0	45	63	20
6	5.0	52	55	17
12	2.6	56	47	32

As can be seen from table 2.13, it was found that by using a small excess of fluorine, the yield of (45) and (47) was high approximately 40% each, while the yield of (48) was relatively low at 8%, conversion was also found to be low at 12%. However, successive increases in the amount of fluorine used, increased the conversion, although the yield of (45) and (47) decreased, whilst the yield of (48) increased. The presence of (46) was also observed in the ^{19}F NMR spectra of the crude products but to the extent of no more than 10% in all cases. At large excesses of fluorine some intractable material was formed and the presence of numerous unidentified products was also observed in the ^{19}F NMR spectra of the crude product.

2.3.4.4 Concluding Remarks

We have found that the fluorination of (44) in sulfuric acid gave four major fluorine containing products in good overall yield. Use of a large excess of fluorine resulted in the preferential formation of (48), while the use of a moderate excess resulted in the preferential formation of (45) and (47). On the other hand, the reaction represents a poor method for the selective formation of fluorinated products, since a mixture of products was obtained. However, whilst not studied in the present work, we envisage that carbocyclic ring substituted isoquinolines have the potential to undergo regioselective direct fluorination, as was found with quinoline derivatives discussed in sections 2.3.1 to 2.3.3 inclusive.

2.4 Chapter 2.0 Summary

We have demonstrated that the direct fluorination of quinoline is possible in concentrated sulfuric acid. Following this observation, we have successfully fluorinated a range of substituted quinolines and have found that the regioselectivity of fluorination is dictated by the substituents in the carbocyclic ring. We have further utilised this methodology in the direct fluorination of isoquinoline, and have demonstrated that direct fluorination can be achieved.

We conclude, that in principle this methodology could be used to prepare a wide range of fluorinated quinoline and isoquinoline derivatives.

Chapter 3.0: The Direct Fluorination of O-Heterocycles

3.1 Introduction

3.1.1 General Introduction

At the time of writing, the synthesis of fluorinated 2H-chromen-2-ones has been accomplished by methods similar to those described in chapter 2, section 2.1.1, namely by the:

- i) Use of N-F and O-F electrophilic fluorinating agents.^{233, 234}
- ii) Balz-Schiemann reactions.²³⁵
- iii) Use of the Halex reaction.²³⁶
- iv) Cyclisation of functionalised pre-fluorinated benzenes, for example, the Pechmann synthesis.²³⁷⁻²⁴¹ Utilisation of pre-fluorinated acyclic components give rise to the corresponding 3- or 4-fluorinated 2H-chromen-2-ones.^{227, 242, 243}

There are a number of disadvantages with the aforementioned routes, for example, with the possible exception of (i), all synthetic methodologies require multistep procedures. Moreover, the N-F and O-F classes of reagents mentioned in (i) cannot be made without involving the use of elemental fluorine.

As a more direct approach, we were therefore interested in exploring the use of elemental fluorine for the preparation of fluorinated 2H-chromen-2-ones, the results of which we will describe in this chapter, and so, literature concerning the preparation of fluorinated 2H-chromen-2-ones derivatives will be reviewed in section 3.2.

3.1.2 Electrophilic halogenation of 2H-chromen-2-one

Electrophilic halogenation of 2H-chromen-2-one (49) is complicated by uncertainties relating to the mechanism and unfortunately, we can find no reports detailing the anticipated regioselectivity of electrophilic substitution.

Under neutral conditions the reactivity order appears to be $3 > 6 > 8$,²⁴⁴⁻²⁴⁶ although, this order is not as simple as it seems since addition across the 3- and 4-

positions^{201, 233, 247, 248} followed by the sequential elimination of HX is also known to give the 3-halogenated product. This reactivity order can be predicted by taking account of the fact that the 3-, 6-, and 8-positions can all conjugate with a lone pair on the ring oxygen, as shown in scheme 3.1.

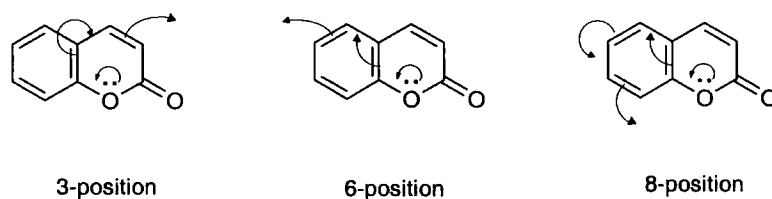

Scheme 3.1

On the other hand, electrophilic substitution under highly acidic conditions (or in the presence of Lewis acids), occurs at the 6- and 8-positions on the protonated form of 2H-chromen-2-one.^{235, 249, 250} Protonation of the carbonyl oxygen results in the involvement of several resonance canonicals, although while theoretically possible, the formation of the benzopyrylium ion and protonation of the heterocyclic ring oxygen were not observed, at least on the NMR timescale (See Scheme 3.2).^{248, 251} Hence, in 2H-chromen-2-one delocalisation of the positive charge over the double bond by an allyl cation type system is preferred over stabilisation by involvement of the ring oxygen lone pairs. It is reasonable to assume, that protonation of the carbonyl group would deactivate the 3- and 4-positions towards electrophilic attack.

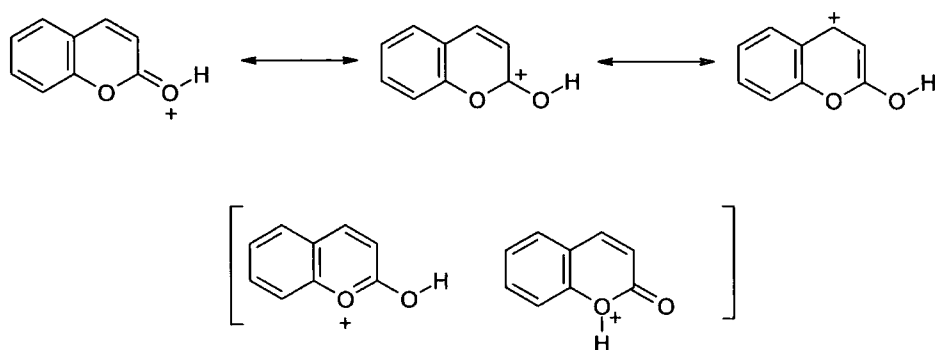

Not Observed in Sulfuric Acid

Scheme 3.2

A somewhat simplified explanation may be obtained by considering the cleavage of the 2H-pyran ring into electron donating and electron withdrawing groups, EDG and EWG respectively. If the positive charge was located at the 4-position then one can divide the pyran ring as shown in scheme 3.3. It is reasonable therefore to anticipate that the 6- and 8-positions would be most reactive towards electrophiles in this system, electrophilic attack occurring *ortho* and *para* to the EDG and *meta* to the EWG.²⁵² However if charge is located at the 2-position or on the carbonyl oxygen, then one can divide the pyran ring as shown in scheme 3.4, where it is anticipated that the 5- and 7-positions would be most reactive. Experimental results would therefore indicate that the former case is more prevalent.

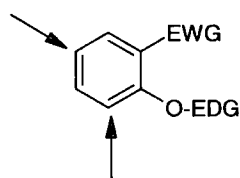

Scheme 3.3

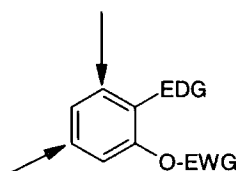

Scheme 3.4

Consideration of charge delocalisation upon electrophilic attack of the protonated 2H-chromen-2-one is more helpful in explaining the observed results, as shown in schemes 3.5 to 3.8. Electrophilic attack at the 5- and 7-positions, as shown in schemes 3.5 and 3.6, would result in some charge delocalisation onto the heterocyclic ring oxygen, and on to the 3-position.

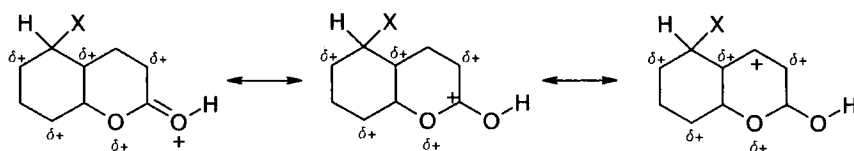

Scheme 3.5

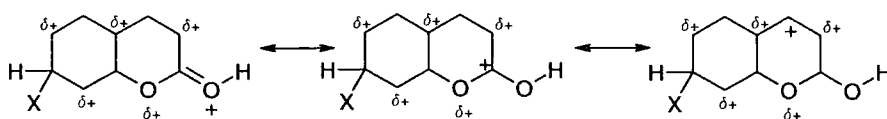

Scheme 3.6

On the other hand, electrophilic attack at the 6- and 8-positions, as depicted in schemes 3.7 and 3.8, would result in some charge delocalisation onto the 2- and 4-positions.

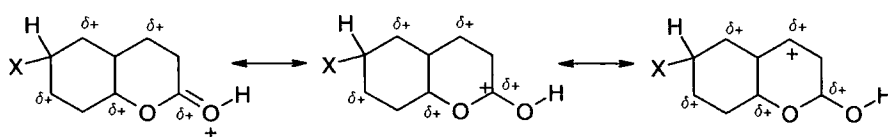

Scheme 3.7

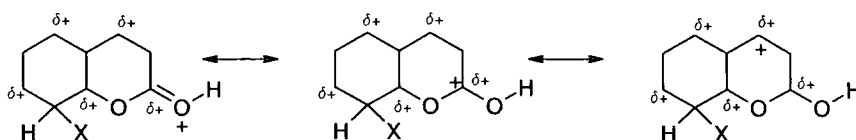

Scheme 3.8

By taking the experimental results of 6- and 8-substitution of 2H-chromen-2-one into consideration, it would seem that the charge delocalisation argument explains the results better than the 2H-pyran ring cleavage argument.^{235, 249, 250} Potential reasons for this are that in the charge delocalisation case (Schemes 3.7 and 3.8), one lone pair on the heterocyclic ring oxygen can stabilise the partial positive charge adjacent to it, furthermore, charge is acquired on existing charged centres in the allyl cation system, namely the 2- and 4- positions which will be stabilised by the presence of the 2-hydroxy group. By comparison, substitution at the 5- and 7- positions would not benefit from these extra stabilisations.

It should be noted that if one were to assume the involvement of the benzopyrylium ion, then by using a similar argument as that described for quinoline (See chapter 2, section 2.1.2), then one would anticipate the electrophilic attack at the 5- and 8-positions.

3.2 Methods for Preparing Fluorinated 2H-Chromen-2-ones

3.2.1 Electrophilic Fluorination

Rozen has described that the reaction between acetyl hypofluorite and (49) gave a 3,4-addition product. Due to rapid enolisation a mixture of *cis* and *trans* isomers was obtained in a 1:1 ratio (See Fig 3.1).²³³ Subsequent elimination of ethanoic acid upon purification or crystallisation resulted in the generation of 3-fluoro-2H-chromen-2-one.

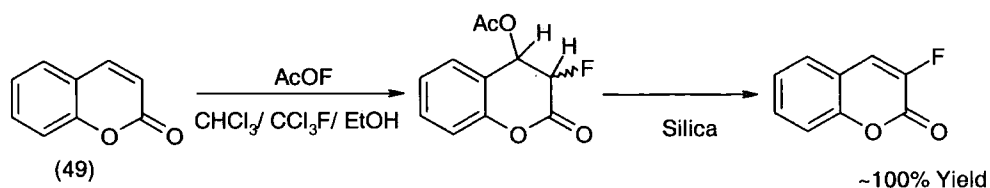

Fig 3.1

Heindel has recently described the selective fluorination of 2H-chromen-2-one derivatives using N-F reagents (See Fig 3.2).²³⁴ Fluorination with Selectfluor[®] was found to occur at the 3-position, albeit in low yield (12-14%), although fluorination using alternative N-F reagents, such as N-fluorobenzenesulfonimide or N-fluoropyridinium triflate, was unsuccessful.

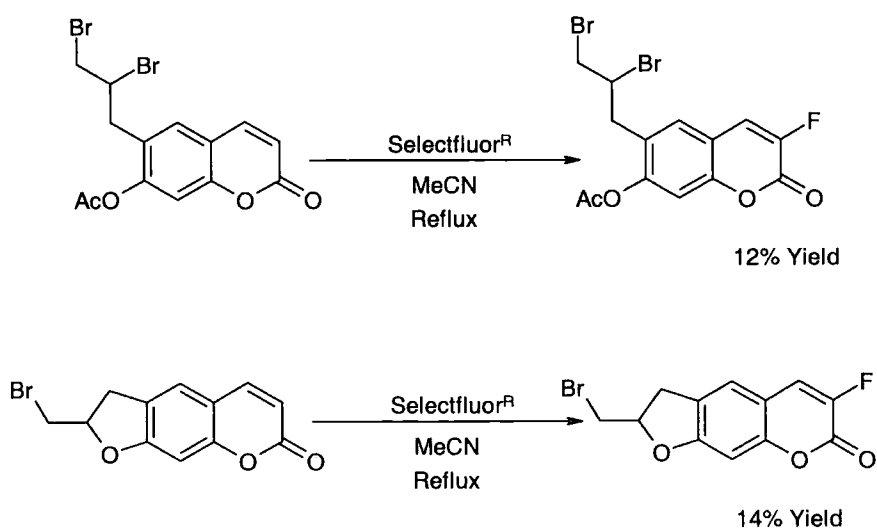

Fig 3.2

3.2.2 Balz-Schiemann Reaction

The Balz-Schiemann reaction has been used to prepare 6- and 8-fluoro-2H-chromen-2-ones from the corresponding amino derivatives as depicted in figure 3.3.²³⁵ The mechanism of fluorination has been described earlier in this thesis (chapter 2, section 2.2.2).

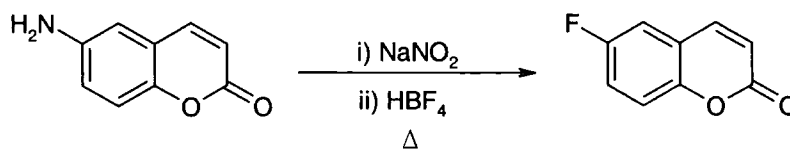

Fig 3.3

3.2.3 Halex Reaction

The halex reaction has been used to prepare substituted 4-fluoro-2H-chromen-2-one derivatives from their respective 4-chloro analogues, as shown in figure 3.4.²³⁶ The mechanism of fluorination has been described earlier in thesis in chapter 2, section 2.2.3.

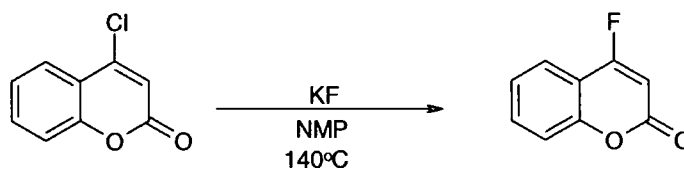

Fig 3.4

3.2.4 Cyclisation Methodology²⁴⁸

Many preparative methods related to the synthesis of 2H-chromen-2-one heterocycles are known. Consequently, this thesis will not describe all existing methods but instead the reader is directed to any good recent heterocyclic textbook. A few reactions will be described to briefly highlight the general art of heterocyclic synthesis.

3.2.4.1 Pechmann Synthesis

The Pechmann reaction involves the acid catalysed reaction between a substituted phenol and a 1,3-ketoester, as shown in figure 3.5. Cyclisation is thought to involve electrophilic aromatic substitution of the phenol, the resulting β -hydroxy ester then cyclised and dehydrates to form the corresponding 2H-chromen-2-one.

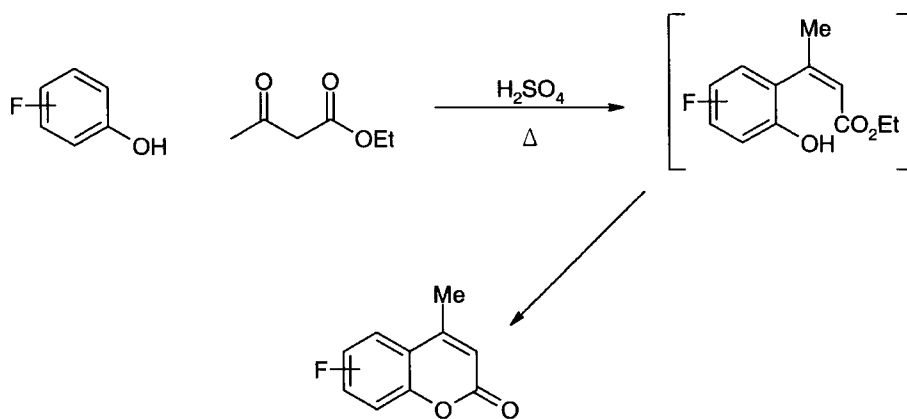

Fig 3.5

3.2.4.2 Knoevenagel Synthesis

The Knoevenagel reaction has been used to prepare 2H-chromen-2-ones. A substituted 2-hydroxybenzaldehyde reacts with an activated methylene compound, such as diethyl malonate, in the presence of piperidine and ethanoic acid, as depicted in figure 3.6, but the mechanism of ring formation is not well defined.

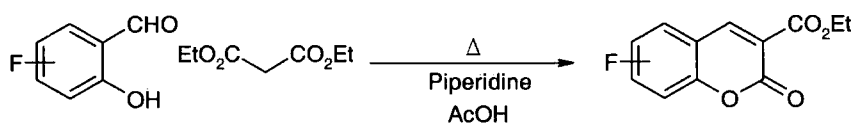

Fig 3.6

3.2.5 Previous Work Involving Elemental Fluorine

An early report describes that the reaction between (49) in CCl_4 , and a deficiency fluorine, resulted in a high amount of fluorine being incorporated into (49).²⁵³ However,

the products were not characterised and one may assume that a complex mixture of fluorinated products would be obtained from such a reaction.

More recent work by Rozen²⁴⁷ details that (49) undergoes addition across the 3,4-positions, giving rise to (55) in moderate yield (See Fig 3.7). Treatment of (55) with silica gel resulted in dehydrofluorination and 3-fluoro-2H-chromen-2-one could be recovered quantitatively. Complementary work undertaken by Sato²⁰¹ showed that fluorine undergoes addition across the 3,4-positions in 4-chloro-2H-chromen-2-one, to give the respective 3,4-difluoro addition product (See Fig 3.7). Treatment of this addition product with silica in an analogous manner was found to result in the formation of 3,4-difluoro-2H-chromen-2-one, by elimination of HCl, in 34% overall yield.

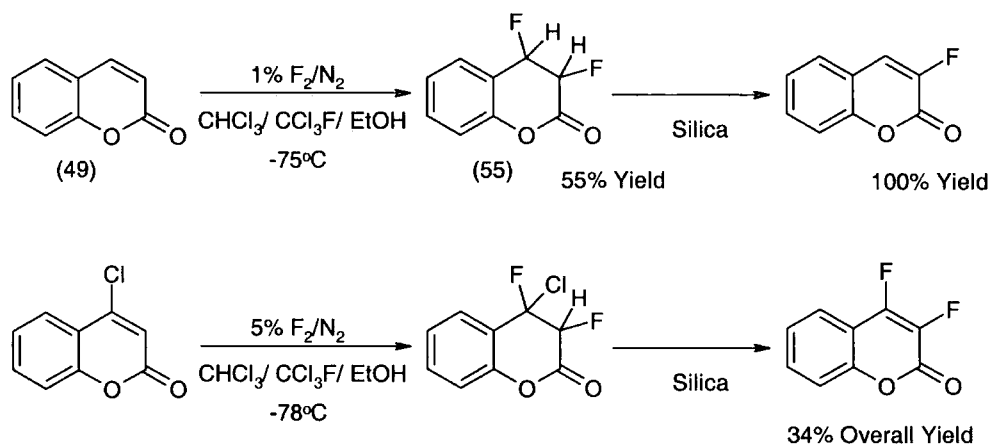

Fig 3.7

3.3 Direct Fluorination of O-Heteroaromatics

3.3.1 2H-Chromen-2-one (49)

3.3.1.1 Solvent Survey

As discussed in chapter 2, sections 2.3.1 and 2.3.4, the selective electrophilic fluorination of (1) and (44) in acetonitrile was unsuccessful. In the light of this, the direct fluorination of (49) was not studied in acetonitrile.

Methanoic acid – The direct fluorination of (49) in methanoic acid gave a mixture of many products, as observed in the ¹⁹F NMR spectrum of the crude product. Within this product mixture were four major products in the proportion of 29%, 11%, 10%, and 22%,

which were later identified as (50), (52), (55), and (56) respectively, as shown in figure 3.8. Identification was made by comparison to literature ^{19}F NMR data^{233, 247, 249} and previous electrophilic substitution work.^{235, 249, 250} The X-ray crystal structure of (52) was established and provides irrefutable proof for its formation, as shown in figure 3.10

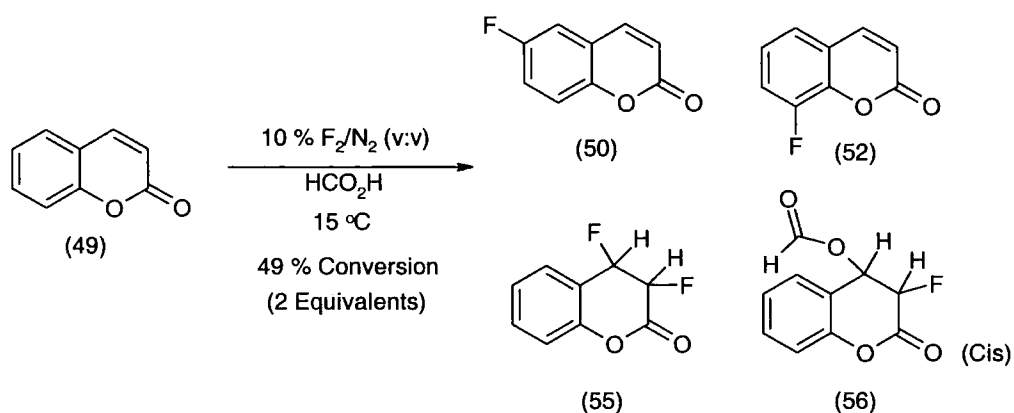

Fig 3.8: (50), (52), (55), (56) in 29%, 11%, 10%, 22% yield respectively

The presence of addition products as well as electrophilic substitution products indicates that fluorination takes place on the un-protonated derivative, although the formation of (50) and (52) could conceivably take place by fluorination on the protonated form.

Sulfuric acid – The direct fluorination of (49) in sulfuric acid gave five major products, four of which were later identified as (50), (52), (53), and (54) by comparison to previous electrophilic substitution work, NMR spectroscopy, and by X-ray crystallography (See Fig 3.9); the fifth product was characterised as (51) and its assignment is discussed later.

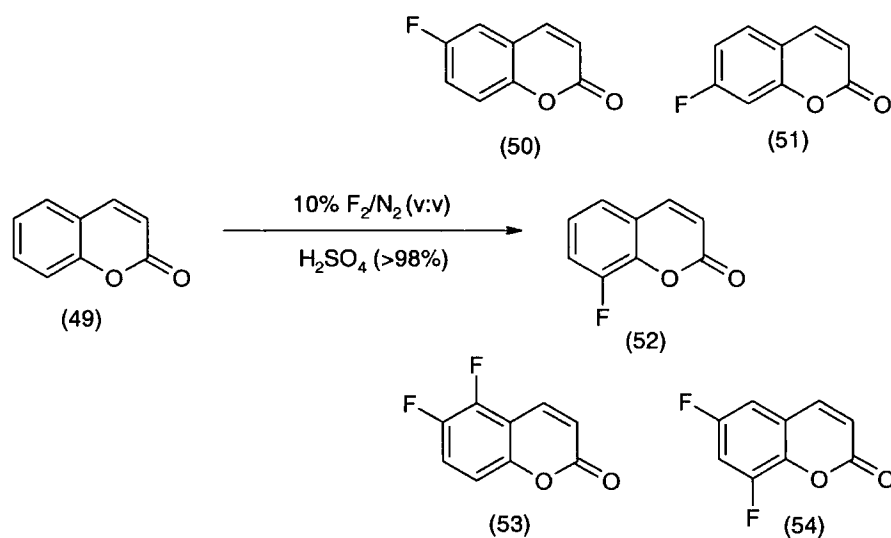

Fig 3.9

Sulfuric acid as reaction medium was found to inhibit the formation of fluorine addition products, which infers the complete protonation of (49), so that electrophilic substitution can only take place on the conjugate acid. Only trace quantities of heterocyclic ring fluorinated products could be detected in the crude ¹⁹F NMR spectrum.

The structure of (53) was derived by NMR analysis, for it is known that in (49), the C-4 α carbon is upfield from the C-8 α carbon.²¹⁶ Using ¹H-¹H COSY and ¹H-¹³C HETCOR NMR, the C-4 α carbon and C-8 α carbon were assigned. The ¹³C NMR spectra showed that the C-4 α was doublet having a ²J_{CF} coupling constant of 16.0Hz, while the C-8 α carbon was a singlet. Hence, it was concluded that one fluorine is present at C-5. Furthermore, both of the fluorine possessing carbons were doublets of doublets, the coupling constants being ¹J_{CF} 246.1Hz, 275.0Hz and ²J_{CF} 11.5, 14.5 respectively. It follows then, that the two fluorines are adjacent to each other, and thus the second fluorine is attached to the C-6 carbon. The X-ray crystal structure of compound (53) confirms the fluorine positions and is depicted in figure 3.11.

We can speculate that the remaining significant product is (51). (However, the ¹⁹F NMR data could not be compared to literature data due to the lack of published ¹⁹F NMR chemical shifts from fluorine atoms in related compounds, although the ¹³C NMR data has been discussed,²⁵⁴ but unfortunately (51) could not be isolated from the product mixture.) The assignment of (51) was made by comparison to ¹⁹F NMR data obtained

from 6- and 7-fluoroquinoline.²¹⁵ The ^{19}F NMR chemical shifts of 6- and 7-fluoroquinoline are -114.2ppm and -110.4ppm respectively. As the ^{19}F NMR shift of (50) is -119.9ppm the peak slightly downfield at -117.9ppm may therefore be from (51). The possibility that this peak is derived from a substituted derivative, such as a sulfonated or hydroxy compound, may also be postulated. However, in an attempt to produce a substituted derivative, a sample of the crude product mixture was agitated in a sodium methoxide/ methanol mixture, and in a separate experiment, in an acidic solution for several days; it should be pointed out that no change in the ^{19}F NMR spectra was observed under either condition. These facts would therefore rule out the formation of a substituted analogue, which would result from nucleophilic attack by water in the reaction solvent or from aqueous work-up upon a difluorinated derivative. Furthermore, as no hydroxylation or sulfonation products have been observed in any preceding experiment, it is unlikely that the ^{19}F NMR resonance is derived from a substituted analogue of (50). The possibility that (51) is 3-fluoro-2H-chromen-2-one may be dismissed by comparison to the literature ^{19}F NMR data, where the 3-fluorine has a chemical shift of \sim -130ppm.^{233, 242, 247}

3.3.1.2 Solvent Survey Conclusion

We have established that sulfuric acid is the preferred solvent for performing direct electrophilic fluorination, since the formation of fluorine addition products is not observed in this medium. Consequently, all further reactions were performed in sulfuric acid.

3.3.1.3 2H-Chromen-2-one (49) in Sulfuric Acid

As discussed in section 3.3.1.2, we have found that the solvent of choice for the direct fluorination of (49) is sulfuric acid. This being so, we have also investigated a range of alternative fluorination reaction conditions, the results of which are presented in table 3.1. Fluorination using two equivalents of fluorine at 15°C, resulted in a 38% conversion, with a 91% total yield of identified products. Increasing the excess of fluorine to six equivalents substantially improved conversion to 76%, however the total yield of identifiable products decreased to 70%. The formation of unknown polyfluorinated

derivatives was also observed in the ^{19}F NMR spectra of the crude product. The yield of the major products can be improved to 96% by lowering the reaction temperature, although this is done at the expense of conversion (53%). However, the ideal situation was determined to be when fluorination was performed at low temperature and with a large excess of fluorine. This reaction gave a good conversion, between 69-72%, with the total yield of major products only decreasing slightly (78-82%).

Table 3.1: Direct fluorination of 2H-chromen-2-one (49) in sulfuric acid

Equivalents of F_2	Reaction Temp ($^{\circ}\text{C}$)	Conversion %	%	%	%	%	%
			Yield of (50)	Yield of (51)	Yield of (52)	Yield of (53)	Yield of (54)
2	15	38	31	30	17	5	7
6	15	76	16	18	7	14	15
6	1	53	27	28	13	13	15
12	1	69	20	22	8	15	17
12	1	72	18	20	7	16	17

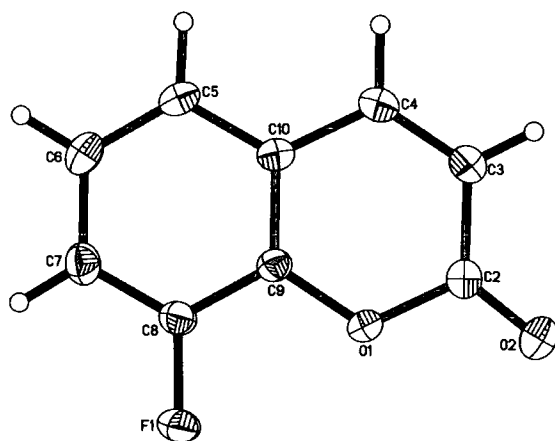

Fig 3.10: X-ray crystal structure of (52) depicted using 50% displacement ellipsoids

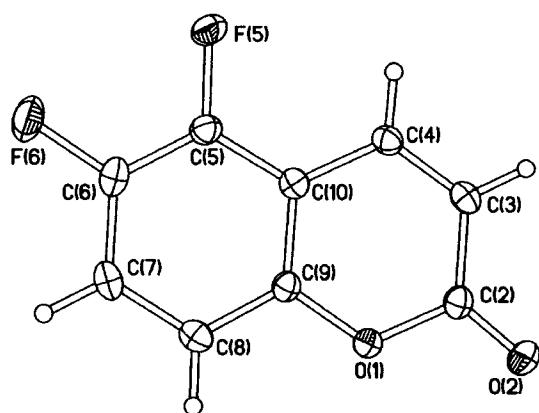

Fig 3.11: X-ray crystal structure of (53) depicted using 50% displacement ellipsoids

3.3.1.4 Concluding Remarks

We have found that the fluorination of (49) in sulfuric acid gave five major fluorinated products in good overall yield. Use of a large excess of fluorine results in high conversion, although the formation of unidentified products increases. Fluorination at lower temperature gave a higher selectivity for the major products.

Unfortunately, the reaction represents a poor method for the selective formation of fluorinated products, since a mixture of products was obtained, but we envisage that substituted derivatives ought to improve the selectivity and this will be discussed in the next section.

3.3.2 Carbocyclic and Carbocyclic/ Heterocyclic Ring Substituted 2H-Chromen-2-ones

3.3.2.1 6-Methyl-2H-chromen-2-one

We are not aware of any reports in the literature describing the direct halogenation of (57). Nevertheless, we have performed the fluorination of (57) in sulfuric acid at 1°C, which gave a 45% conversion and one major product as well as a significant minor product, as observed in the ^{19}F NMR spectrum of the crude product mixture (See Fig 3.12 and Table 3.2). The proportions of these two products were 78% and 8%, which were subsequently identified as (58) and (59) respectively.

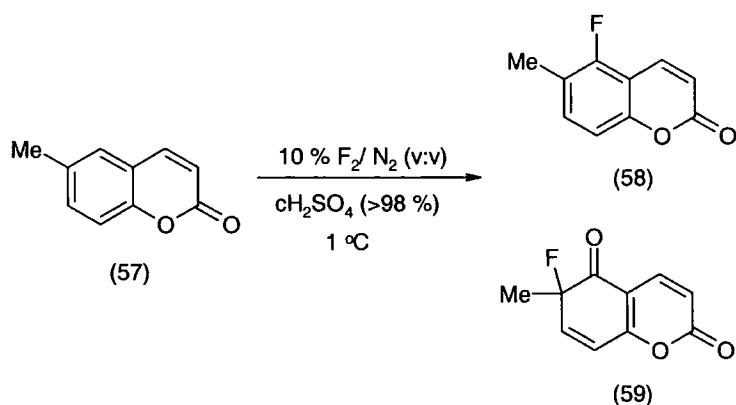

Fig 3.12

Product (58), was assigned by analysis of the ^{13}C and 1H NMR data. The ^{13}C NMR data was particularly useful since the C-8 α carbon was a doublet with a $^3J_{CF}$ coupling constant of 4.6Hz, while the C-4 α carbon was a doublet with a $^2J_{CF}$ coupling constant of 16.0Hz. Thus it was concluded that fluorine was present at C-5. Further evidence for the formation of (58) was obtained from its X-ray crystal structure, which is shown in figure 3.13. The latter of the two products (59), was assigned by comparison to work described in chapter 2, sections 2.3.3.5 and 2.3.3.9. The X-ray crystal structure was obtained, which is depicted in figure 3.14, and provides irrefutable proof for its formation. Moreover, the ^{13}C NMR data is consistent with the structure of (59), the C-5 and C-7 carbons were both found to be doublets of doublets with $^2J_{CF}$ coupling constants of 16.4Hz and 23.3Hz respectively. Furthermore, the 6-methyl group was also found to be a doublet in the ^{13}C NMR with a $^2J_{CF}$ coupling constant of 26.6Hz.



Table 3.2: Direct fluorination of 6-methyl-2H-chromen-2-one (57) using 5 equivalents of fluorine

% Conversion	% Yield of (58)	% Yield of (59)
45	78	8
46	77	9
52*	69	10

* Reaction performed on 5.0g scale; reaction solvent consisted of sulfuric acid (>98%) (90ml) and water (10ml)

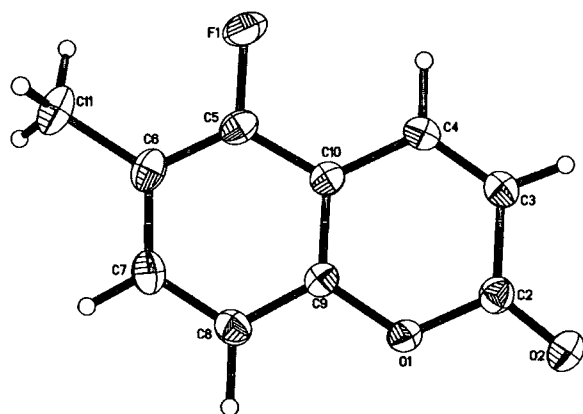

Fig 3.13: X-ray crystal structure of (58) depicted using 50% displacement ellipsoids

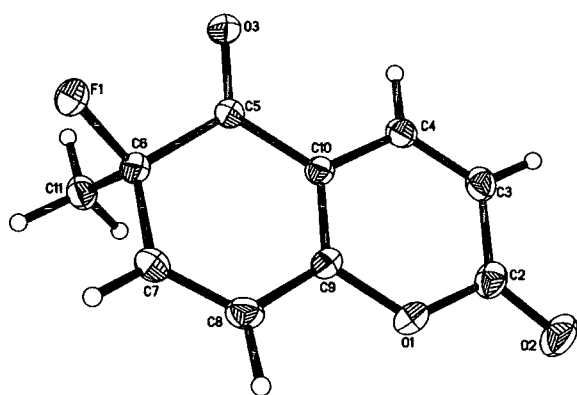

Fig 3.14: X-ray crystal structure of (59) depicted using 50% displacement ellipsoids

The formation of (59) is thought to occur in an analogous manner to the formation of (43) as discussed in chapter 2, section 2.3.3.9. Electrophilic fluorination occurs first at the 5-position to give (58) as shown in figure 3.15, which is followed by the addition of fluorine across the 6- and 7-positions to give (58i). Nucleophilic attack at C-5 in (58i) by water followed by the loss of two molecules of HF, via (58ii) would give (59).

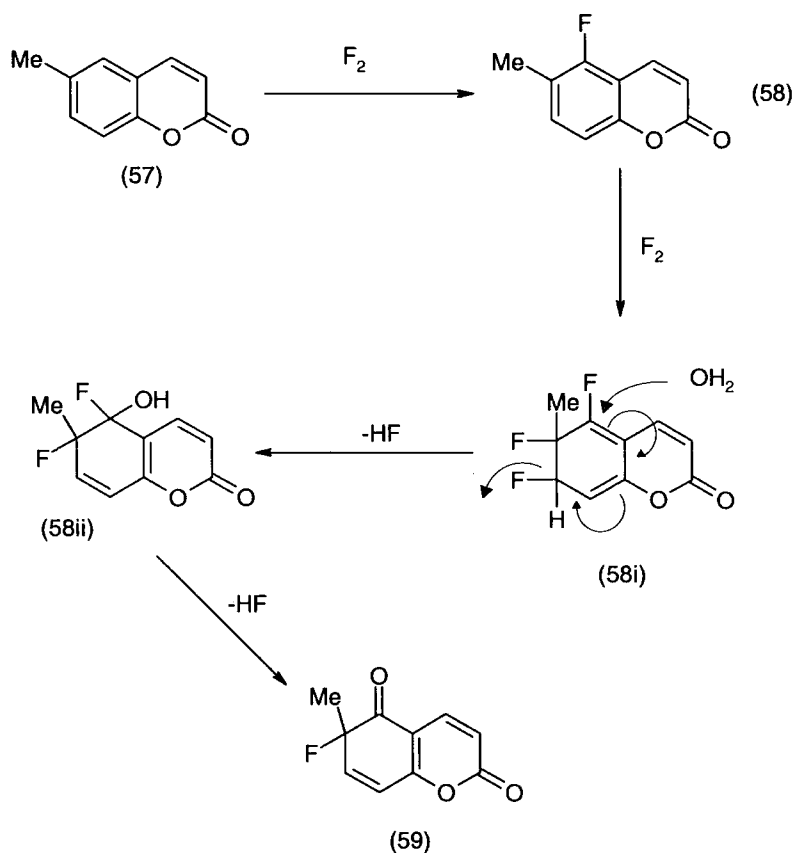

Fig 3.15

In conclusion, we have found that by the introduction of the 6-methyl group, electrophilic fluorination is promoted at the 5-position. Furthermore, we have evidence that (58) undergoes a further reaction with fluorine to eventually give (59).

3.3.2.2 7-Methoxy-2H-chromen-2-one

Dalvi and Lele have reported the bromination and iodination of several 4-methyl derivatives, although these reports will be described in section 3.3.2.3.^{244, 245}

We have found that the direct fluorination of (60) with five equivalents of fluorine gave a conversion of 55% and two major products, which were later identified as (61) and (63) respectively (See Fig 3.16 and Table 3.3). It was subsequently found that if the work-up procedure was changed to include an ethyl ethanoate extraction, then more of the products could be extracted and thus the conversion was calculated to be higher. The formation of (63) is thought to occur via a similar mechanism as shown in chapter 2, section 2.3.3.1, figure 2.17.

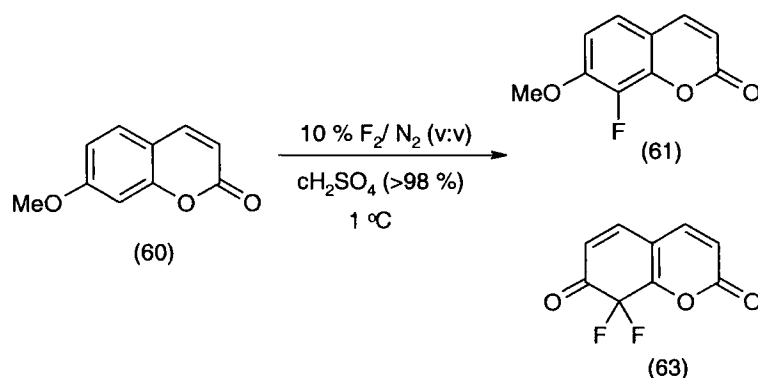

Fig 3.16

The identification of (61) was made by examination of the ¹H-¹H COSY and ¹H-¹³C HETCOR NMR spectra, which allowed the assignment of the C-4 α and C-8 α carbons. The C-8 α carbon was found to be a doublet with a ²J_{CF} coupling constant of 7.4Hz, while the C-4 α carbon was found to be a singlet. It was concluded that the fluorine was present at the C-8 position. Further conclusive proof was obtained from the X-ray crystal structure of (61), which is depicted in figure 3.17. Compound (63) was identified by comparison of the ¹⁹F NMR data to that obtained from compounds (19) and (22). Moreover, analysis of the ¹³C NMR spectra showed the C-8 α carbon to be a triplet having a ²J_{CF} coupling constant of 22.5Hz, while the C-4 α carbon was a triplet with a ³J_{CF} coupling constant of 6.5Hz. Furthermore, the X-ray crystal structure gave irrefutable proof for its formation, as shown in figure 3.18.

Table 3.3: Direct fluorination of 7-methoxy-2H-chromen-2-one (60)

Equivalents of F ₂	% Conversion	% Yield of (61)	% Yield of (63)
5	55	70	20
5	65 ^ζ	66	23
10	75 ^ζ	0	75
10	78 ^ζ	0	75
10*	94 ^ζ	0	72

ζ= Extraction with dichloromethane then ethyl ethanoate, * Reaction performed on a 4.1 g scale.

Fluorination performed with a large excess of fluorine (ten equivalents) only slightly increased the conversion, although the complete transformation of (61) into (63) was observed. Minor products were also detected in the ¹⁹F NMR spectra of the crude product, and were identified as (62) and (64), as shown in figure 3.19. The former product (62) was identified by comparison to literature data obtained from the 4-methyl analogue,²⁴¹ while the latter product was observed as a minor component in the X-ray crystal structure of (63), and by analysis of the ¹⁹F NMR data. The latter product is thought to be derived from (62), via a mechanism analogous to the formation of (63) from (61).

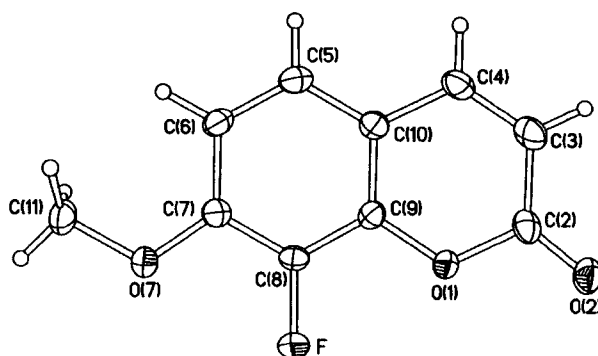

Fig 3.17: X-ray crystal structure of (61) depicted using 50% displacement ellipsoids

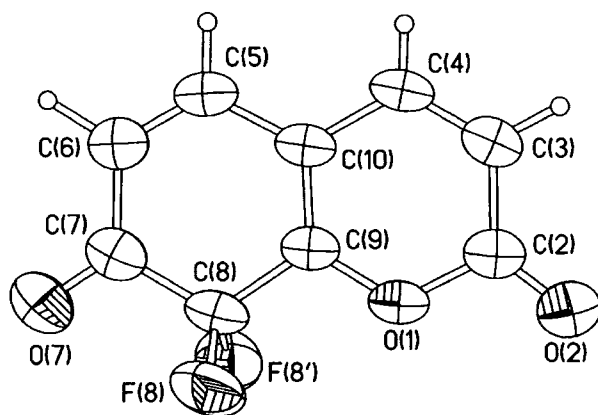

Fig 3.18: X-ray crystal structure of (63) depicted using 50% displacement ellipsoids

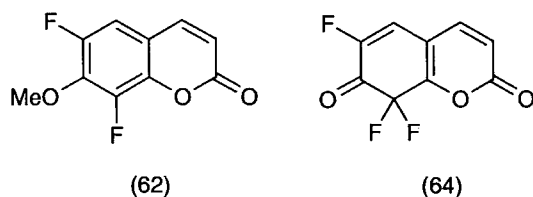

Fig 3.19

We have found that the introduction of the 7-methoxy group increases the regioselectivity of electrophilic fluorination at the C-8 position. Moreover, it has been found that further fluorination preferentially takes place at the C-8 position.

3.3.2.3 7-Ethoxy-4-methyl-2H-chromen-2-one

As briefly described in section 3.3.2.2, the bromination and iodination of 7-hydroxy/methoxy derivatives of (65) has been described by Dalvi and Lele respectively.^{244, 245} Bromination was performed in ethanoic acid with one equivalent of bromine,²⁴⁴ which led to the 3-bromo derivative in all cases studied. However, the use of two equivalents of bromine, led to the formation of 3,6- and 3,8-dibromo derivatives, which upon further bromination gave the 3,6,8-tribromoderivative. On the other hand, iodination of the 7-hydroxy/ methoxy derivatives was studied under a range of conditions.²⁴⁵ Iodination of the 7-hydroxy derivative of (65) with one equivalent of iodine monochloride in ethanoic acid gave the 7-hydroxy-8-iodo derivative of (66) as the only isolatable product in 25% yield. Moreover, iodination using iodine in iodic acid or iodine in a KI solution in the

presence of ammonia, led to the formation of higher yields of the 8-iodo derivative in 40% and 82% respectively. The use of multiple equivalents of reagents resulted in the formation of 3,6-, 3,8-, and 3,6,8-triiodo derivatives.

We have found that using 2.5 equivalents of fluorine, a 60% conversion can be obtained. Analysis of the ^{19}F NMR spectra of the crude product mixture showed that two major products were obtained in 66% and 12% yield, which were later identified as (66) and (68) respectively (See Fig 3.20 and Table 3.4).

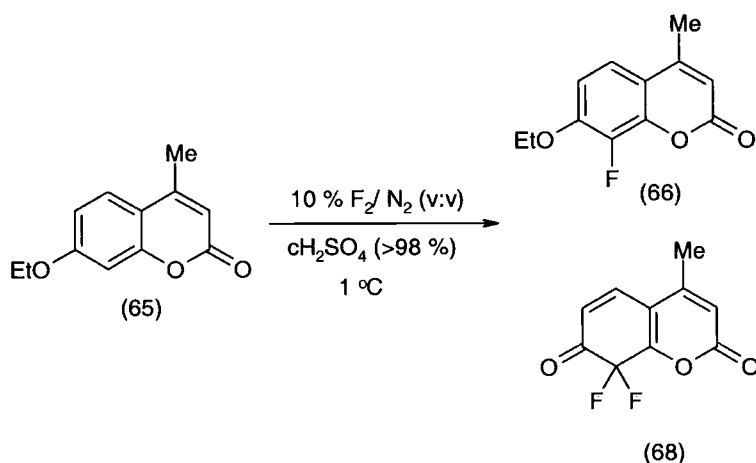

Fig 3.20

Compound (66) was identified by comparison of the ^{19}F NMR data to the literature data obtained from the 7-methoxy derivative of (66).²⁴¹ Further conclusive evidence was obtained from the X-ray crystal structure, which is shown in figure 3.21. The latter product (68) was identified by comparison of the NMR data to that obtained from (63) (See Section 3.3.2.2). The ^{13}C NMR spectra showed the C-4 α carbon to be a triplet with a $^3J_{\text{CF}}$ coupling constant of 6.7Hz, while the C-8 α carbon was a triplet with a $^2J_{\text{CF}}$ coupling constant of 21.5Hz, thus it may be concluded that two fluorines are at the C-8 position.

Table 3.4: Direct fluorination of 7-ethoxy-4-methyl-2H-chromen-2-one (65)

Equivalents of Fluorine	% Conversion	% Yield of (66)	% Yield of (68)
2.5	60	66	12
5.0	76	55	26
10.0	68*	0	80

* Reaction performed on a larger scale

The use of five equivalents of fluorine increased the conversion to 76% at the expense of the yield of (66). However, an increase in the yield of (68) accompanied the decrease in (66). It was found that using a large excess of fluorine, the complete transformation of (66) into (68) could be achieved, although accompanying (68) was the formation of minor products, namely (67) and (69), which are depicted in figure 3.22. These minor products were identified by comparison to literature ^{19}F NMR data²⁴¹ and by comparison to previous experimental data obtained from (62) and (64) respectively.

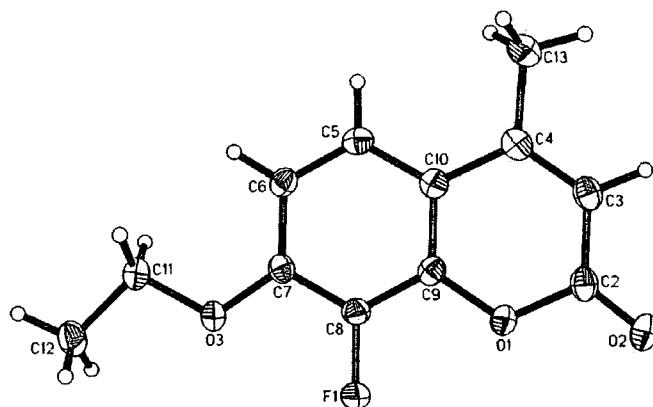

Fig 3.21: X-ray crystal structure of (66) depicted using 50% displacement ellipsoids

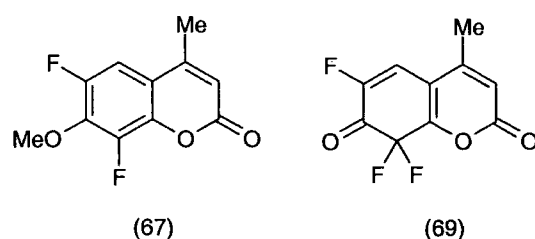

Fig 3.22

We have found that the introduction of the 7-ethoxy group increases the regioselectivity of electrophilic fluorination at the C-8 position. Moreover, it has been found that further fluorination preferentially takes place at the C-8 position. The presence of the 4-methyl substituent was not found to influence the regioselectivity of electrophilic fluorination, which is consistent with the conclusions drawn from heterocyclic ring substituted quinolines discussed in chapter 2, section 2.3.2.3. If the conversions are considered, (65) appears to be more reactive than (60), however this increase in reactivity may partly be due to the 7-ethoxy group and partly due to the 4-methyl group.

3.4 Chapter 3.0 Summary

We have shown that the direct fluorination of 2H-chromen-2-one with elemental fluorine can be achieved, in most cases efficiently, using concentrated sulfuric acid as a reaction medium. Following this observation, we have successfully fluorinated a range of substituted 2H-chromen-2-ones and have found that the regioselectivity of fluorination is dictated by the substituents in the carbocyclic ring. Moreover, we have shown that heterocyclic ring substituted 2H-chromen-2-ones do not influence, at least to any great extent, the regioselectivity of electrophilic substitution. In the large majority of products identified, product distribution mirrors other halogenation work published in the literature. We conclude that in principle, direct fluorination methodology opens up new routes to selectively fluorinated 2H-chromen-2-one compounds, and to novel fluorinated compounds difficult to synthesise by any other means.

Chapter 4.0: General Introduction-Microreactor Technology

4.1 Introduction

Before the advantages associated with utilising microreactor technology are discussed, it is necessary to highlight some important points concerning the manufacture of chemicals and to introduce the concept of process intensification.

4.1.1 Conventional Chemical Manufacturing

Large-scale chemical production is a complicated process²⁵⁵⁻²⁵⁷ and the development of a new process, or more commonly an improved product route, in a laboratory is only the beginning. Commercialisation of the new process requires that a reaction be scaled-up from laboratory scale to larger scale production in order to meet the potential market demand of the product; this development is referred to as process development and can be expensive, laborious, and time consuming.

Objectives that influence the research and development of a chemical process to the manufacturing scale are:²⁵⁸

- Process product safety
- Environmental issues
- Waste minimisation
- Energy minimisation
- Operability and control
- Financial investment minimisation

Therefore, an ideal process should be safe, efficient, easily controlled, and inexpensive; although it should be realised that it is not always possible to achieve all the factors.

An important decision that must be made early in process development is whether the new process will be operated in a batch or continuous manner. Several factors dictate this decision, such as the scale of a process, kinetics, and thermodynamics. Continuous processes are generally desired for large-scale operations (greater than 5,000 tonsy⁻¹) and

generally give high product consistencies, whereas batch processes are desired for smaller outputs (less than 1,000 tons y^{-1} , although used frequently up to 5,000 tons y^{-1}), although variable product consistencies can be obtained.^{256, 257}

Before full-scale production is contemplated, laboratory experimental data is acquired in order to give a better understanding of the reaction. However, insufficient data is frequently collected from these experiments and consequently a pilot plant is required prior to full-scale production (a pilot plant is a small scale version of the full scale plant), as shown in figure 4.1.

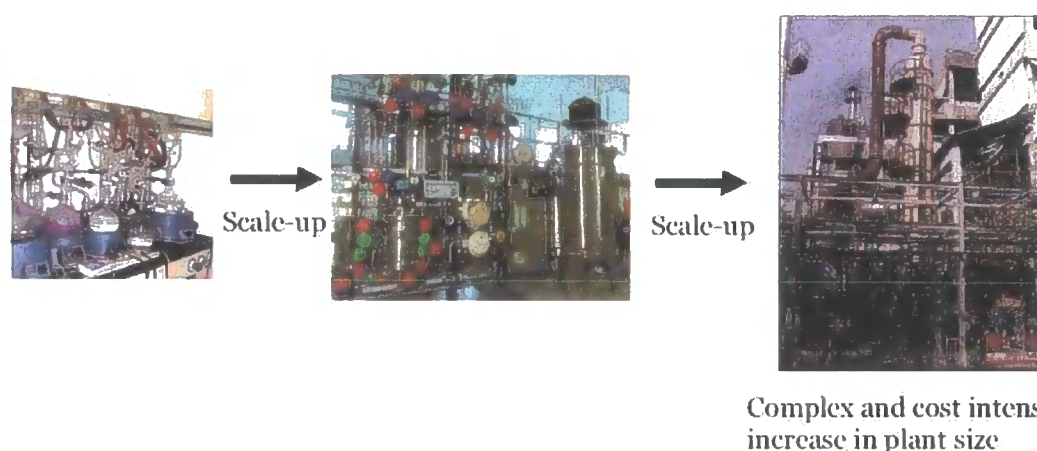

Fig 4.1: Conventional scale-up process: laboratory, to pilot plant, to large industrial scale production

Unsurprisingly, problems are unavoidably encountered by scaling up a reaction, in fact, it is known that increasing the scale of the reaction decreases the control one has. Heat and mass transfer (i.e. mixing) become increasingly difficult over large distances, and huge efforts are applied in order to ensure uniform homogeneity in large reaction vessels. A consequence of poor heat and mass transfer in larger reaction vessels is that unexpected or higher levels of by-products are obtained, when compared to the laboratory scale reaction. As a result, considerable time and resources are applied to solving these problems. One potential solution to these problems has been described²⁵⁹⁻²⁶¹ and involves the intensification of the chemical process, as discussed below.

4.1.2 Process Intensification

As mentioned above, process intensification is one solution to these scale-up problems,²⁵⁹⁻²⁶² and refers to technologies and strategies that enable the physical size of a conventional process to be reduced. This is not a new concept and was originally suggested approximately two decades ago by Ramshaw, who recognised that the financial investment required to install a bulk chemical manufacturing plant could be reduced significantly by reducing the sheer size of the facility. It should be pointed out that approximately 80% of the total cost of installing a chemical facility is derived from its installation, and includes the external pipe work, structural support, and civil engineering expenses.

4.2 Microreactor Definition

Before a discussion concerning the concept of microreactor technology can begin,²⁶³ it is first pertinent to define what is meant by the term 'microreactor'. This term has been used in a broad sense in the literature, for example, small particulate catalysts have been described as microreactors,²⁶⁴ as could be considered biological enzymes. However, the term microreactor in this review refers to chemical reactors having structures less than one millimetre in size but greater than the sub-micrometer, in at least one dimension.

Microreactors may vary in overall size, but can still be classified as microreactors if they possess sub-millimetre structures. The large overall size of a device may be due to the need to sufficiently seal the device or because the device has other apparatus built into the microreactor unit, such as reagent reservoirs, heat exchanger, or pre-mixer systems.

4.2.1 Advantages of Microreactors

Microreactor technology has the potential to revolutionise the chemical industry,^{263, 265, 266} and there are several reasons why microreactors are currently receiving attention, as follows:

- Benefits due to decrease in physical size (volume effects)
- Advantages due to an increase in the number of units
- Potential benefits of microreactor applications

4.2.2.1 Physical Benefits

For a given physical property, decreasing the linear dimension increases the respective temperature, concentration, or pressure gradients.^{263, 266} While an in-depth mathematical proof is not given here in this thesis, simple predictions have been made concerning heat and mass transport.

Heat transfer - Currently, microreactor/ heat exchanger devices contain microchannels with widths between 0.05mm to 0.5mm. If the separating wall material between the reaction and heat transfer medium can be minimised to between 20-50 μ m, then the heat transfer coefficients may be as high as 25,000Wm⁻²K (Watts per square meter per Kelvin).²⁶³ Conventional heat exchangers have heat transfer coefficients by at least one order of magnitude lower, typically around 2,500Wm⁻²K. As a result of improved heat and mass transfer, localised hotspot formation is reduced, as is by-product formation, which is usually caused as a consequence of hotspot formation. In fact improved heat transfer is exemplified in a report by Löwe who designed a microreactor that cools a gas mixture from 1,100°C to 120°C over a distance of 0.3mm in 0.1ms, thus giving a theoretical cooling rate of 10,000,000 Ks⁻¹.^{267, 268}

Mass transfer - A decrease in fluid layer thickness increases the surface-to-volume ratio of the fluid, and hence the specific surface area of microchannels can amount to between 10,000 to 50,000m²m⁻³.^{263, 266} On the other hand, typical laboratory or industrial production vessels do not exceed 1,000m²m⁻³ and 100m²m⁻³ respectively. Moreover, similar benefits are to be expected for multiphase processes, when at least one of the fluid phases has a layer thickness in the micrometer range. Estimations of film thicknesses have showed that the specific interfaces of such multiphase systems can be in the range of 5000 to 30,000m²m⁻³. Indeed, Jähnisch has reported that a gas-liquid falling film microreactor attained a specific interfacial interface of 27,000m²m⁻³, while a microbubble column gave an interface of 9,800m²m⁻³.^{169, 260}

High heat and mass transfer can improve the overall yield of product, by reducing hotspot formation and hence by-product formation. The reaction is therefore more efficient, meaning less waste, and thus product is obtained more cheaply. These gains in efficiency/ waste minimisation are very important when one considers the increasingly stricter environmental legislation.

Operation of highly exothermic reactions can now be accomplished with complete safety and control using microreactor technology. Indeed, reactions may be operated above conventional methodology explosion limits.²⁶⁹

Reactor volume - Decreasing linear dimensions, leads to a decrease in the overall volume of microreactors, the volumes being typically of the order of a few millilitres or less (For example, decreasing all the dimensions by a factor of ten will result in a one thousand fold volume decrease.)^{263, 266} The difference becomes even larger when in combination with reactor miniaturisation, a large-scale batch process may be replaced by continuous flow operation in one or more microdevices. For example, the material hold-up could be decreased from a tank of several thousand litres to a volume of a few millimetres. A smaller reaction vessel obviously infers less reagents are present in the vessel, and hence the potential for thermal runaway is reduced significantly.²⁶⁶ Reducing the size of a chemical process has further benefits associated with on-site production,^{263, 266} and becomes even more important when one considers that hazardous compounds can be produced where required. Hence, safety issues associated with hazardous chemical storage and transport are reduced. This point of on-site production has been highlighted by NASA, who intend to use microreactors to produce propellants, oxygen and other useful chemicals from carbon dioxide and possibly water on Mars.^{261, 270}

4.2.2.2 Scale-Out

The key advantage of microreactors is the ease of potential scale-out by an arithmetic process, instead of scale-up, which refers to an increase in the overall size of the microreactor and is illustrated in figure 4.2.^{263, 266}

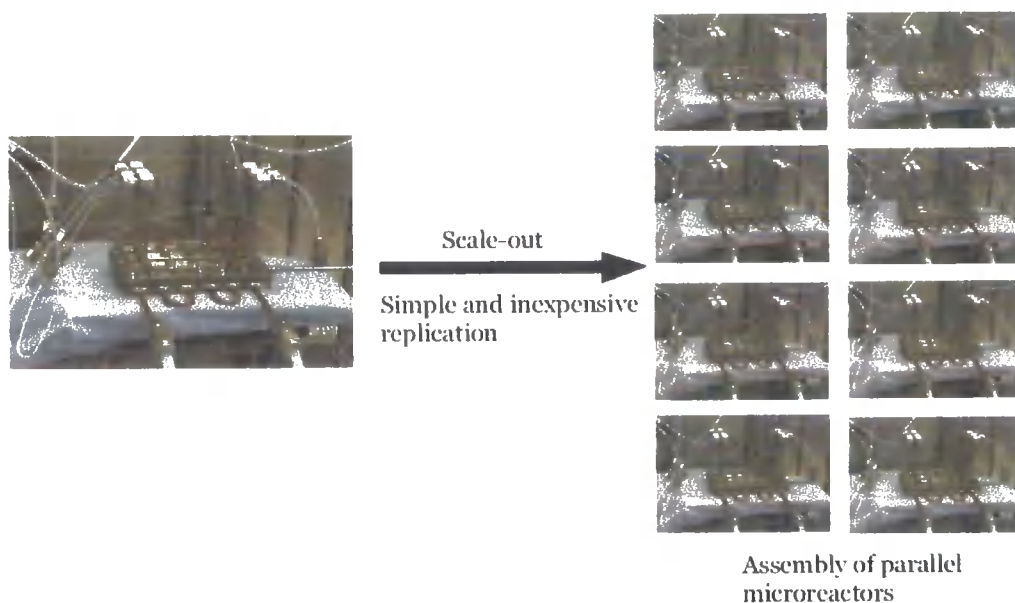

Fig 4.2: General example of the microreactor scale-out concept

Using conventional scale-up theory, a commercially important laboratory bench reaction is scaled-up, eventually to a pilot plant. If still further quantities of material are required then the pilot plant is scaled-up to an industrial plant. In the intermittent period, considerable time, financial investment, and effort is applied to solving the problems caused by poor heat and mass transfer in these large reaction vessels, for example undesired by-product formation and mixing.

On the other hand, once a chemical reaction has been optimised in a microreactor, scale-out theory allows a theoretically infinite increase in parallel microreactor operation. Hence, the desired quantity of product can be obtained by simply scaling-out the number of microreactors until the desired output is obtained.

Conceivably, a microreactor chemical plant could be constructed from many parallel units and thus create the possibility of supply and demand. The desired numbers of reactors are simply selected. Furthermore, if one considers reactor maintenance then downtime while a bulk reactor is repaired will effect production enormously. However, the repair of one microreactor could be achieved without effecting production, and indeed, a replacement reactor could be installed to replace the defective one. Failure of all microreactors simultaneously would be extremely improbable.

In fact, the concept of scale-out has already been demonstrated by Merck KGaA.²⁷¹ They found that the percentage yield of product obtained by the operation of five minireactors, was analogous to the use of one minireactor. For comparison, other reaction vessels have been compared in table 4.1. Moreover, scale-out theory has the benefit that if market conditions change then the production of a chemical can be rapidly changed also by increasing/ decreasing the number of microreactors in operation.

Table 4.1: A comparison of reactor technology

Reactor Type	Temperature °C	Residence Time in Reactor	% Yield
0.5 litre flask	-40	0.5h	88
6m ³ Stirred production vessel	-20	5h	72
Microreactor	-10	<10s	95
Minireactor	-10	<10s	92
5 x Minireactors	-10	<10s	92

4.2.2.3 Disadvantages of Microreactors

It should be pointed out that microreactor technology is not suitable for all reactions. The nature of microreactors having sub-millimetre dimensions requires that solutions are free from particulates, and that the reaction does not produce any insoluble particulate matter that may congeal and block the reactor. However, the use of minireactors as described by Merck KGaA,²⁷¹ can solve this problem and beneficial properties of the much smaller size of the reactor are still observed.

A further problem with microreactors is that rapid reaction rates are required to offset the short residence time within the microreactor, although this can be modified to some extent by incorporating longer reaction channels, which increases the residence time within the microreactor.

A detrimental process that is often overlooked in microreactor design is corrosion. As a result, materials of reactor construction are of paramount importance when considering the lifetime of the reactor. As for conventional bulk reactors, choice of an inappropriate construction material could lead to the reactor becoming rapidly unusable. Consequently, a considerable effort is required in order to determine the most chemically resistant reactor material. In fact, for bulk reactor construction, the thickness of the reactor vessel wall is not only sufficient to allow for the temperature/ pressure of the reaction, but also to allow for the corrosion which will occur over the lifetime of the reactor vessel. For microreactors, their very nature, in that they possess structures with micro-dimensions (<1mm), requires that the rate of corrosion of a particular material has to be taken extremely seriously, if one considers their long term use.

For example, the corrosion rate of stainless steel (type 316) in an unaerated boiling solution of 90% methanoic acid is $0.36\text{mm}\cdot\text{y}^{-1}$;²⁷² under the same conditions, the corrosion rate of Monel alloy 400 is $0.03\text{mm}\cdot\text{y}^{-1}$. It can be argued then that for a bulk reactor with a wall thickness of several tens of millimetres, that both corrosion rates are proportionally insignificant. On the other hand, for a microreactor possessing structures less than one millimetre in size then these corrosion rates are proportionally very significant. Moreover, the increased surface areas within microreactors would be expected to increase the corrosion rate of the material.

Fortunately, a wide range of materials exist from which a relatively resistant material to the particular type of corrosion could be found, furthermore, thin protective layers may also be formed over microreactor structures to prolong the use of the device.²⁶³

Moreover, the fact that microreactor replication should be relatively inexpensive would ensure that corroded devices could be replaced easily, although ideally, one would not want to replace corroded microreactors too frequently.

4.3 Types of Microreactor

Microreactors can be classed into one of three groups: liquid-liquid, gas-liquid, and gas-gas, although microreactors in which solid catalysts are embedded into the channels also exist. Gas-liquid microreactors are relevant to the work discussed in this thesis and the

properties associated with using these types of microreactor will be presented below. Properties of liquid-liquid and gas-gas reactions will not be discussed in this thesis and the reader is directed to the literature and the references cited therein.^{263, 265}

4.3.1 Gas-Liquid Phase Flow in Microchannels

The majority of work concerning gas-liquid flows has been studied on relatively large diameter tubes, typically 50mm in diameter. However, it has been found that gas-liquid flows performed in small (~1mm diameter) tubes, mirror those obtained from larger scale experiments, and hence flow regimes described on the macro scale are equally applicable to those on the micro scale.²⁷³ The only difference observed between the two systems was that the transition from one flow regime into the next occurred under different conditions.

For a two-phase gas-liquid system there are several flow regimes, and it is therefore necessary to define the regimes independently for vertical and horizontal flow. It should be pointed out that these flows are very complex and are not fully understood, although a thorough mathematical treatment has been described by Hewitt concerning two-phase flow in large cylindrical tubes.²⁷⁴ Furthermore, the use of non-cylindrical tubes for two-phase flow further complicates the issue, since the liquid phase will not be distributed evenly around the periphery of the tube.

4.3.1.1 Vertical Gas-Liquid Phase Flows

Several flow regimes are possible in vertical gas-liquid flows, and the regime observed is dependant on the relative rates of liquid and gas flow. If the rate of the liquid flow is kept constant while the rate of the gas flow is changed from relatively low flow rate to a very high flow rate, then the flow regimes shown in figure 4.3 will result.

Bubbly flow: Gas phase is distributed in discrete bubbles within the liquid column.

Slug flow: Some of the gas bubbles have nearly the same cross-section as that of the channel and move along in characteristic bullet shaped bubbles.

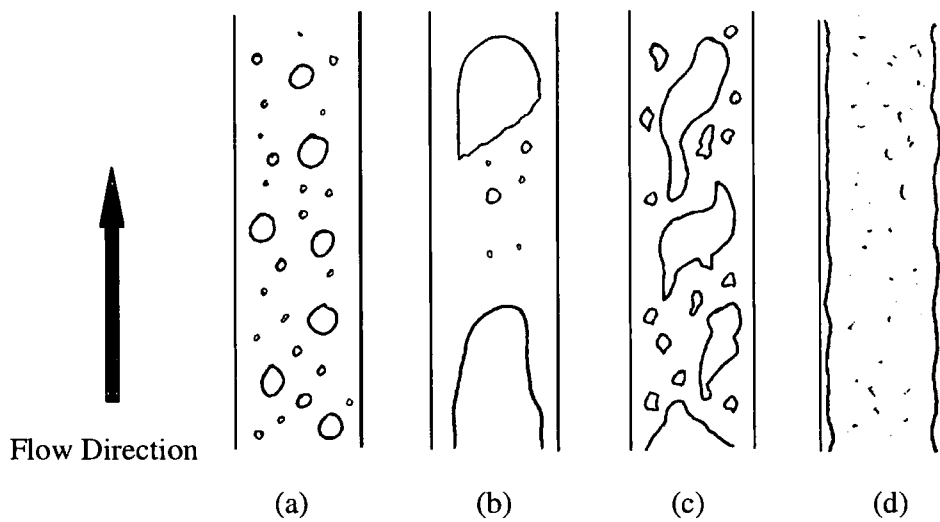

Fig 4.3: (a) Bubbly flow, (b) Slug flow, (c) Churn flow, and (d) Annular flow.

Churn flow: At higher gas velocities, the structure of the gas bubble will eventually become unstable. In wide bore tubes, the instability eventually results in churning, while in narrow tubes, the transition between slug and annular flow is smoother.

Annular flow: The liquid forms a film on the surface of the tube, which is more or less a continuous interface to a stream consisting mainly of gas. The gas flows in the centre of the tube, and may or may not contain liquid droplets, likewise the liquid film may or may not contain gas bubbles. Film thickness in vertical two-phase flow is effectively constant around the periphery of the tube. It is worth pointing out that intrinsic annular flow is only achievable in cylindrical tubes. For cases using non-cylindrical tubes, i.e. square tubes, this term is called channel or pipe flow, due to the liquid film being thicker in the corners.

A falling film is also possible in vertical two-phase flow and occurs where a liquid continuously flows down a vertical surface under the influence of gravity. The gas flow passes over this falling film in either counter-current, or co-current manner.

4.3.1.2 Horizontal Gas-Liquid Flow

Horizontal gas-liquid flow is more complicated than vertical flow, since gravity acts perpendicular to the flow. Consequently, an influence on gas and liquid flow is observed, which causes an asymmetric distribution of the phases, and is depicted in figure 4.4. As described in section 4.3.1.1, liquid flow rate is held constant, while the rate of gas flow is increased.

Bubbly flow: Defined as for vertical flow, however there is a tendency for the bubbles to flow in the upper part of the channel.

Plug flow: Similar to slug flow in the vertical case, although the liquid layer separating the gas bubbles from the surface of the tube tends to be thicker at the bottom of the channel than the top.

Stratified flow: Separation of the liquid and gas is complete, the liquid flowing at the bottom of the channel and the gas at the top.

Wavy flow: Increased gas velocity produces large surface waves in the stratified flow regime.

Slug flow: As the gas flow is increased further, the waves eventually become large enough to reach the top of the tube, and as a result, a film of the liquid is left behind.

Annular flow: At very high gas flows the slugs become pierced with a gas core and the flow is essentially annular, however the effect of gravity results in a thicker film forming at the bottom than at the top of the tube. As described above, it is worth pointing out that intrinsic annular flow is only achieved in cylindrical tubes. For cases using non-cylindrical tubes this term is called channel or pipe flow.

However as already mentioned, horizontal two-phase annular flow displays a more complicated behaviour. Gravity acts in a direction perpendicular to the flow, which produces a circumferential flow in the liquid film. This flow becomes superimposed on

the axial flow, or that is to say, the liquid film becomes thicker at the bottom than at the top. Fortunately, this effect is negligible over short distances (below ~ 0.1 meters from the point of injection), but at large distances (in the order of a couple of meters from the point of injection), significant differences in film thickness are observed and flow eventually becomes laminar.

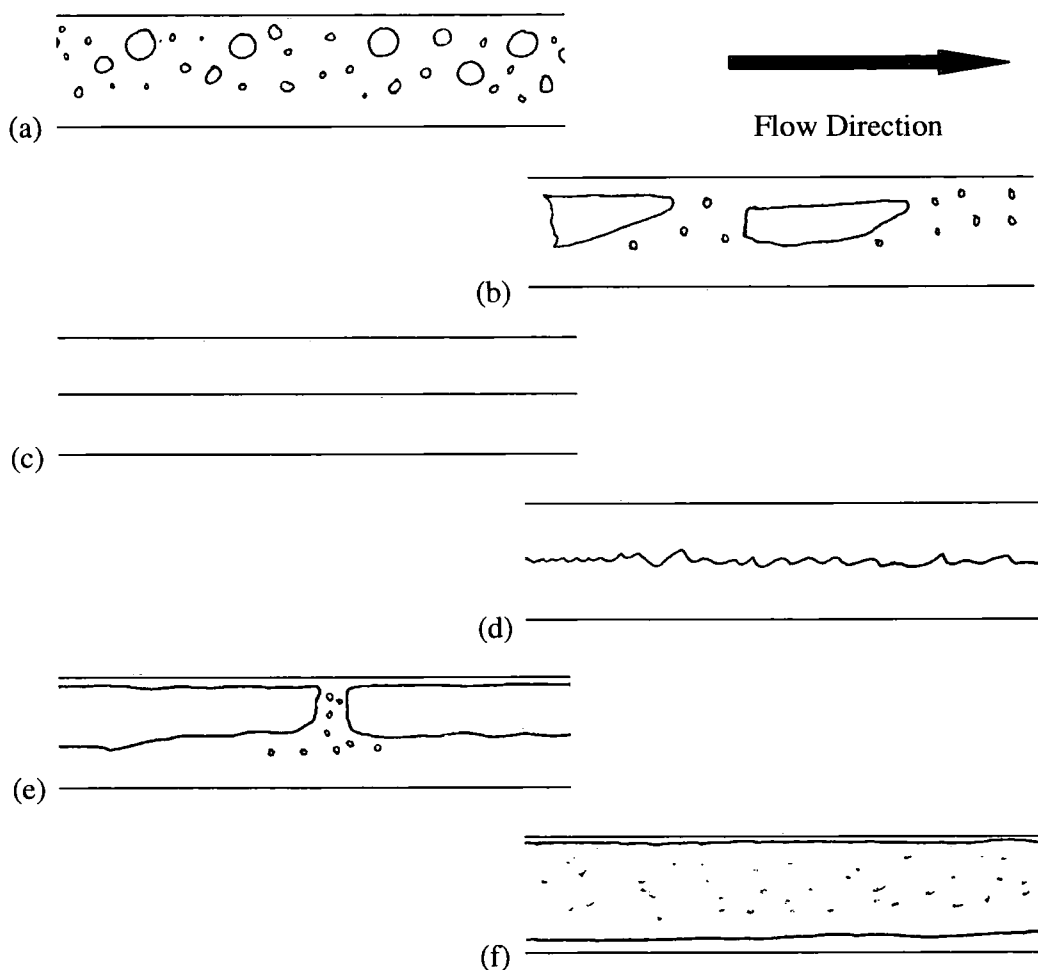

Fig 4.4: (a) Bubbly flow, (b) Plug flow, (c) Stratified flow, (d) Wavy flow, (e) Slug flow, and (f) Annular flow

4.4 Microreactor Fabrication Techniques²⁶³

Microreactor fabrication can be achieved by a number of different engineering techniques, although while conventional engineering techniques can be used to some extent in the construction of microreactors, in most cases these techniques cannot be used

in the generation of more intricate structures. The material of construction often dictates the fabrication technique chosen, although several techniques may still be used for any given material. Other factors, which also have to be considered when choosing a fabrication technique are relative cost, accuracy, and repeatability of the process. The actual construction of a microreactor may involve a range of techniques, chosen from conventional precision engineering to specialist microfabrication techniques.

Currently, there exists a large range of fabrication techniques, and consequently it is not the aim of this thesis to review them all. However, techniques used in the construction of microreactors presented in chapter 5 will be briefly reviewed below.

4.4.1 Computer Aided Design (CAD)

The design of structurally complicated devices has been assisted enormously by the development of computer aided design software (CAD software). This software allows the scale drawing of a device to be realised, whereby design analysis and problem solving can be completed in a much more efficient fashion. Moreover, the general appearance of the device can be obtained even before construction. It is also important to realise that modern engineering fabrication techniques are now computer controlled, by so called CNC controllers (Computer Numerical Control), which has allowed the CAD design schematics of a part to be quickly transferred to CNC controllers. As a result, the fabrication process of a particular part can be nearly fully automated, which has the benefits of higher product quality and consistency, far higher than those obtained by manual operation.^{275, 276}

4.4.2 Conventional Machining Techniques

For drilling, the tool most commonly used is the twist drill, as shown in figure 4.5. The material to be drilled is clamped, while the rapidly rotating drill tool is slowly moved down toward the material surface. The end of the twist drill has two cutting edges. Clearance of removed material from the hole is achieved by the flutes, which are the spiral grooves running up the tool. The essential feature of drilling is that the cutting speed along the cutting edge varies, the maximum cutting speed being found at the edge,

which allows the generation of a cylindrical surface. This technique allows the generation of long cylindrical recesses, as depicted in figure 4.6.

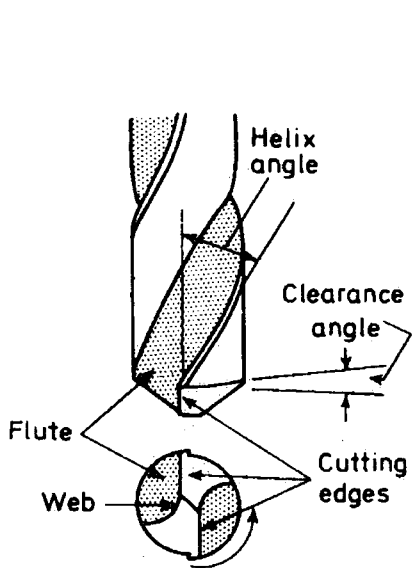

Fig 4.5: A drill tool

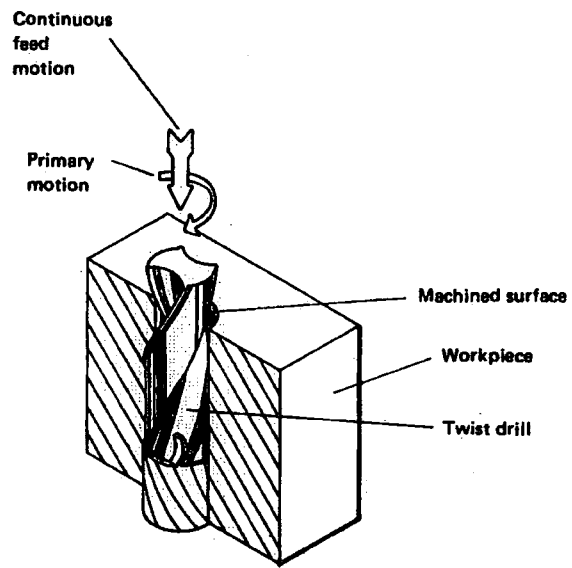

Fig 4.6: The process of drilling

For milling, circular cutting tools which have numerous cutting edges are used, typically between three and one hundred edges, an example is shown in figure 4.7. The rapidly rotating cutting tool is held stationary, while the material to be milled is clamped in position and slowly moved past the cutting tool. The speed at which the material is moved past the milling tool is typically no greater than 0.25mm/ per cutting edge. However, because a large number of cutting edges can be used per tool, then the rate of milling can be quite rapid. This technique is generally used for fabricating grooves and flat surfaces, although other applications are possible.²⁷⁷

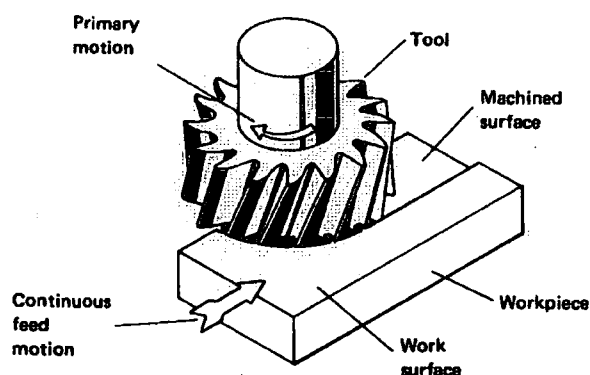

Fig 4.7: Milling of a block of metal

It is worth noting that while conventional machining has been used extensively in the fabrication of microreactors, within the last five years ultra-precise machining techniques have been developed. For example, diamond tipped tools allow precision machining to the nanometer scale.²⁷⁸

4.4.3 Electric Discharge Machining (EDM)

Several derivatives of the same technique exist, namely EDM drilling, EDM wire machining, and EDM die sinking. The principle behind all of the aforementioned techniques involves the generation of a high-energy discharge from an electrode to an electrically conductive material surface, which requires that metal and metal alloys being the only materials that can be fashioned using these techniques. The intense high-energy discharging (or sparking) erodes both the electrode and the metal surface, and consequently, the electrodes have to be replaced from time to time. The electrode is brought to between 0.01-0.5mm from the material surface, where a voltage exceeding the breakdown voltage of the gap is supplied. A channel is ionised at the two closest points, between the electrode and the material, which causes a massive current flow and erosion of a particle of metal. The ionised channel consists of plasma, at between 8000 to 12,000°C, made up from ionised metal atoms; sparking may take place up to 500,000 times second.

EDM drilling involves the use of a small hollow brass tube electrode, slightly smaller than the hole to be drilled, through which a wash fluid flows. The tube is slowly moved in a downward motion toward the metal surface and as the tube gets closer to the

metal surface, the high-energy discharge erodes the surface and produces an indent, which gets deeper as the electrode is moved downwards, until the desired hole depth is reached. The wash fluid passing through the tube washes away debris generated in the process so that the surface to be eroded is constantly cleaned.

EDM wire machining involves a similar principle, but instead of a brass tube, a continually moving brass wire is used, as depicted in figure 4.8. The technique is used to cut unusual shapes from sheet metal.

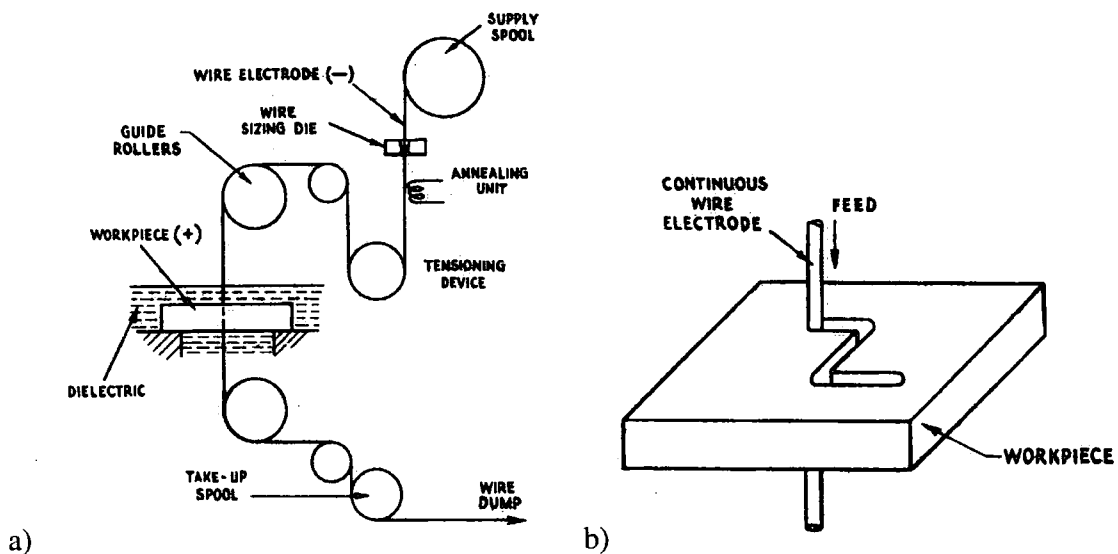

Fig 4.8: (a) Depicts the general set-up of EDM wire machining, while (b) shows a close-up of machining taking place

EDM die sinking involves the use of a three-dimensional electrode which possess the negative image of the structure to be machined, for example the fabrication of a hole in a metal surface would require an electrode with the corresponding raised section, as shown in figure 4.9. It should be pointed out that these two latter techniques are usually performed in a dielectric liquid.^{273, 279}

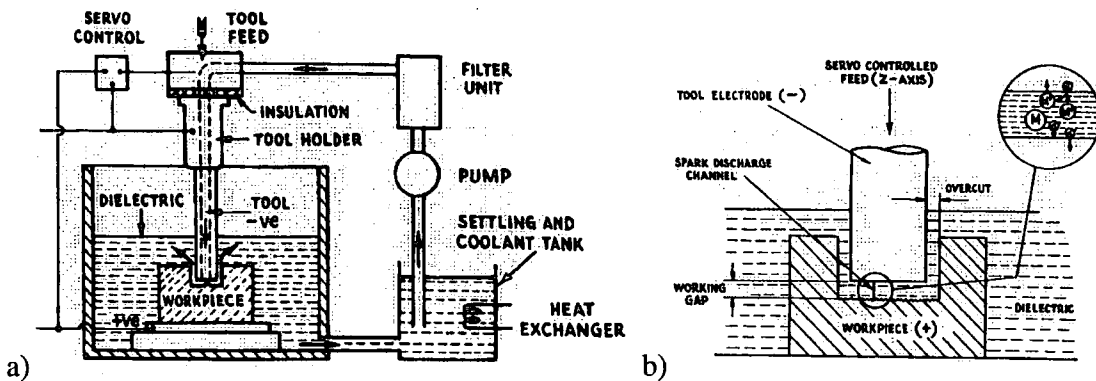

Fig 4.9: (a) Depicts the apparatus of EDM die sinking, while (b) shows a close-up of the erosion process

Recent advancements regarding the EDM technique, have resulted in the development of miniaturised procedures, where micro-drilling and micro-die sinking are achieved. For example, the fabrication of holes $10\mu\text{m}$ in diameter has been achieved using μEDM drilling.²⁶³

4.4.4 Etching

Several etching techniques are known, and were mainly developed for the semiconductor industry. However, some of these techniques have been adapted for use with glass and metal substrates. The common principle behind all the etching techniques is that a protective photoresist material is coated onto the surface of the material to be etched, as shown in figure 4.10. This photoresist is then subjected to UV radiation through a template mask, which results in the exposed photoresist becoming labile to removal. The labile photoresist is removed, for example by a chemical means, thereby exposing the surface of the desired pattern. The material is then etched, leaving behind a recess of the desired shape, time of etching being proportional to the depth of the recess. The photoresist is subsequently removed to leave the patterned surface. Wet etching is the most common technique used, although dry etching with a low pressure plasma is possible.^{263, 280}

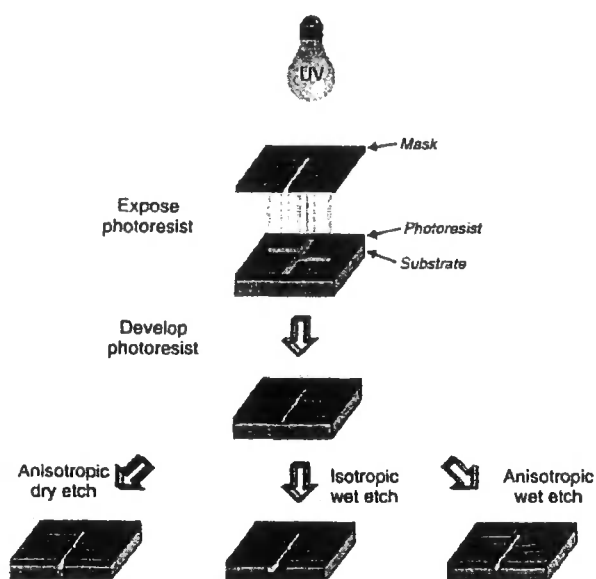

Fig 4.10: Etching process²⁸¹

4.4.5 Laser Cutting

The range of materials that can be cut using lasers is enormous; metals, polymers, and ceramics are to name just a few. The basic mechanism of laser cutting involves focusing the laser light on to the surface of the material to be cut. This focused light beam heats the material and creates a very localised melt region along the depth of the material. A stream of pressurised gas acting in the same direction as the laser beam assists the removal of this molten material. The laser is moved around the sheet to generate the cut. Lasers are generally used to cut two-dimensional shapes from sheet material, but three dimensional depth profiling is possible. The most commonly used lasers, especially in microfabrication, are carbon dioxide (CO₂) and neodymium aluminium garnet lasers (Nd:YAG).^{273, 282, 283}

4.5 Elemental Halogenation Microreactors - A Review

General microreactor technology has been reviewed recently, and hence the reader is directed to that literature and to the references cited therein.^{263, 265, 273, 284-288} However, direct halogenation microreactors are relevant to the work described in this thesis, and therefore these will be reviewed thoroughly.

With the exception of direct iodination, microreactors have been fabricated to perform the bromination, chlorination, and fluorination of organic compounds, and these halogenation microreactors will be discussed below.

4.5.1 Bromination Microreactor

Fabian has reported the use of a microreactor for the direct bromination of 1,3,5-trimethylbenzene.²⁸⁹ Bromine and 1,3,5-trimethylbenzene are both dissolved in CCl_4 and passed into the microreactor at a rate of $10\mu\text{min}^{-1}$ (0.06mlh^{-1}), through separate inlet orifices. In the microreactor, the two streams are mixed in a microchannel where reaction takes place (See Fig 4.11). Conversion was found to be nearly quantitative, with a high selectivity for the monobrominated product. Increasing the flow rate of the reagents to $20\mu\text{min}^{-1}$ (0.12mlh^{-1}) resulted in quantitative conversion, although a significant decrease in the yield of the monobrominated product was observed.

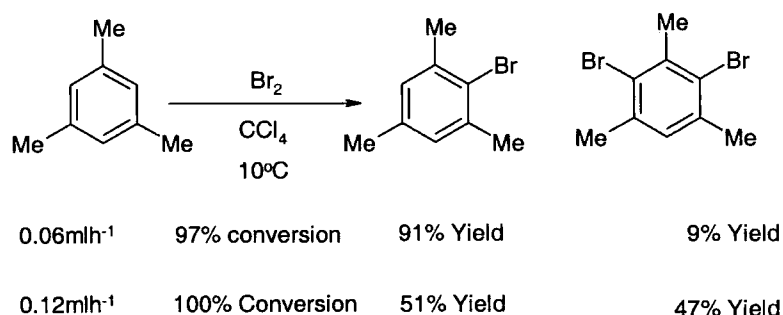

Fig 4.11

4.5.2 Chlorination Microreactor

Wehle and Schuppich have described a heated microreactor for the direct chlorination of organic acids.^{171, 290} The microreactor possesses a highly intricate design (See Fig 4.12), and has several important features. The design of the microreactor allows many reactors to be used back to back, which is useful for scale-out purposes. Moreover, one single microreactor unit has been designed so that reactions can be performed on both sides of the reactor. Furthermore, liquid and gaseous reagents can be distributed to many channels simultaneously via small reservoir structures. Chlorination takes place in small

groves fabricated onto a so-called fluid guidance plate, below which the heating medium flows. Channels have a cross-sectional area of 0.3mm by 1.5mm.

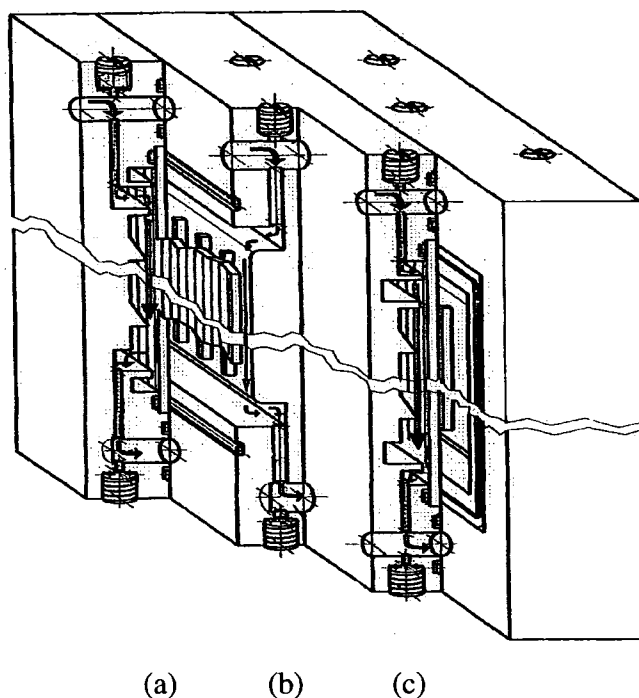

Fig 4.12: Sections through the gas-liquid chlorination microreactor. Cut-away section (a) path of the liquid through the microreactor, (b) path of the coolant medium through the microreactor, (c) path of the gas through the microreactor. It should be noted that gas and liquid flow through the same channels, and not separately as shown in the diagram, which merely highlights the flow from their respective orifices.

In the chlorination examples described by Wehle and Schuppich, the majority of the microreactor was fabricated from graphite, with the exception of the fluid guidance plate, which was constructed from tantalum. It was found that the direct chlorination of ethanoic acid gave an 85% conversion and >99% yield of chloroethanoic acid (See Fig 4.13). Dichlorinated derivatives were found to be present to the extent of <1%. As a result, the purification of chloroethanoic acid is simplified, as ethanoic acid is removed by simple distillation. Chlorination using the aforementioned microreactor was found to be much improved over conventional bubble column methodology, where the formation

The selective and perfluorination of organic compounds directly by elemental fluorine was described, and in both cases, high conversions and yields were obtained (See Fig 4.15). For example, the selective fluorination of ethyl 3-oxobutanoate (70) resulted in the formation of the 2-fluoro derivative (71) in 73% yield, while conversion was reported to be nearly quantitative. Moreover, the perfluorination of a partially fluorinated ether gave the perfluorinated derivative in 91% yield, although it should be pointed out that perfluorination required an additional heated step downstream of the microreactor.

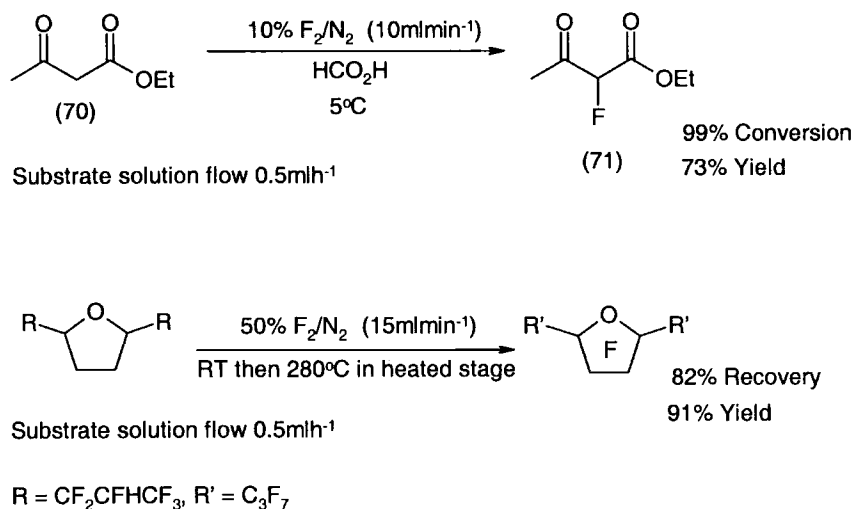

Fig 4.15

Hessel and Jähnisch have designed two microreactors for the direct fluorination of methylbenzene, namely a microbubble column microreactor and a falling thin film microreactor.^{166, 169} Both consist of a stainless steel housing and a nickel so-called fluid guidance or channel plate. Cooling of the reactor is attained by a separate channel system located in close proximity adjacent to the fluid guidance plate.

Fluorination using the microbubble column involves the generation of a continuous stream of small bubbles in a flow of liquid. The microbubble column apparatus and simple diagram of the concept is presented in figures 4.16 and 4.17 while the flow pattern of the gas-liquid flow achieved is depicted in figure 4.18. Two different channel sizes were used, namely 0.3 mm by 0.15 mm and 0.05 mm by 0.05 mm, although the latter reactor dimensions gave superior results.

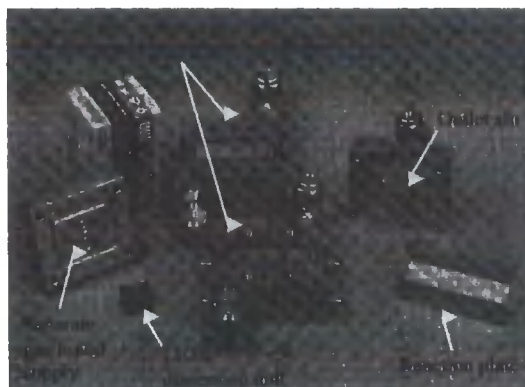

Fig 4.16

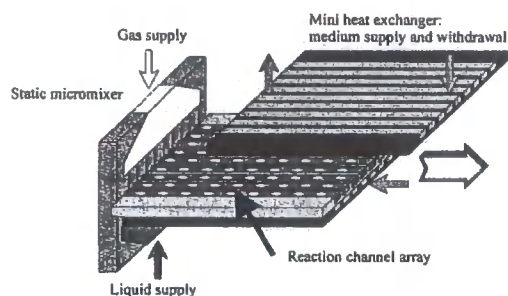

Fig 4.17

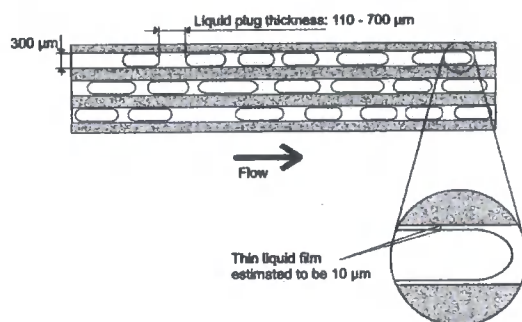

Fig 4.18

The falling film microreactor involves the generation of a thin film contained within microchannels of 0.1mm by 0.3mm cross-sectional area, which is achieved by a slow continuous flow of liquid from many small orifices. Fluorine is simultaneously passed over this thin film, in a headspace above the reactor channels. The design of the reactor requires that the liquid film not in the temperature controlled region be protected from fluorine, so that premature contact and hence reaction is not obtained. As a result a so-called contact zone mask is used to prevent fluorine coming into contact with the liquid phase until in the cooled reaction zone. The falling thin film microreactor apparatus and simple diagram of the concept is presented in figure 4.19.

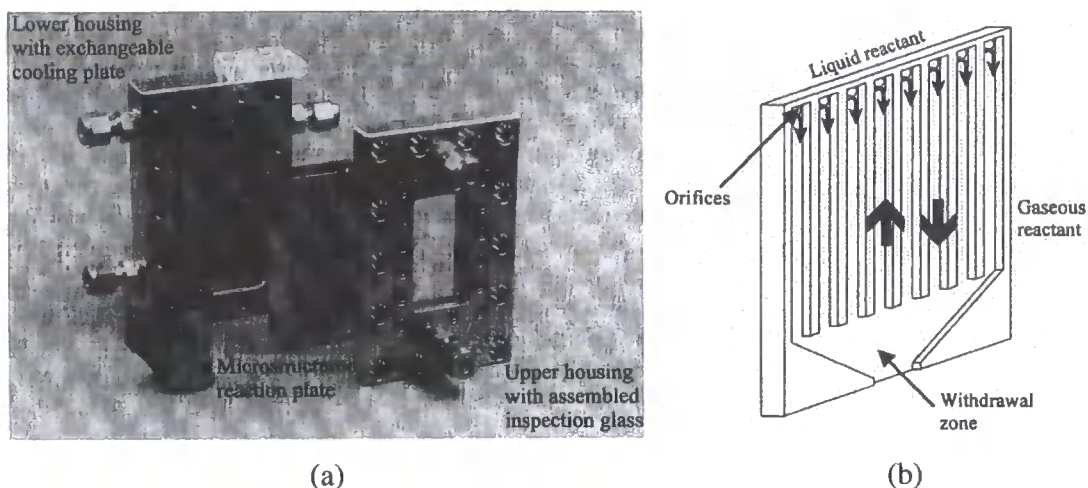

Fig 4.19: (a) Shows a disassembled photograph of the falling thin film microreactor, while (b) shows a simple diagram of the gas-liquid reactor fluid guidance plate.

Direct fluorination of methylbenzene (See Fig 4.20) using these aforementioned microreactors was studied under a range of reaction parameters, the results of which were compared to a laboratory macro bubble column benchmark. Increasing the ratio of fluorine to methylbenzene was found to increase the conversion, as did increasing the reaction temperature. The general conclusion, which was drawn from these experiments was that both the microbubble column and the falling thin film microreactor were far superior to the benchmark reactor, and moreover, higher conversions could be achieved using the falling thin film microreactor.

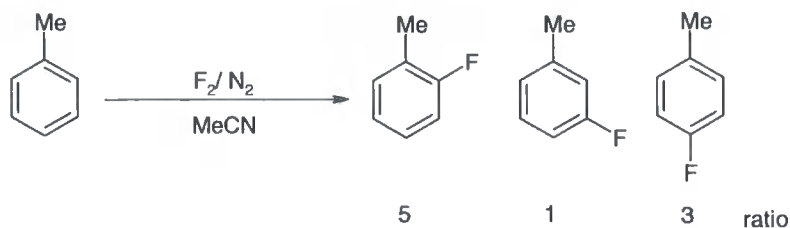

Fig 4.20

A further report by de Mas describes the fluorination of methylbenzene in a microreactor fabricated from a silicon wafer, onto which a thin nickel layer had been deposited.¹⁶⁷ Two parallel prismatic reactor channels of 0.4mm by 0.28mm cross-

sectional area, were fabricated by etching a silicon wafer. Channels are enclosed by the addition of a further nickel coated silicon wafer, which are subsequently bonded together, as shown in figure 4.21. Fluorination was performed under a range of conditions, the results of which were similar to those obtained by Hessel and Jähnisch.^{166, 169} Unfortunately, it was found that after many experiments, the thin nickel films lost their adhesion to the silicon, and hence the reactor would become unusable, due to corrosion, especially by fluorine and HF.

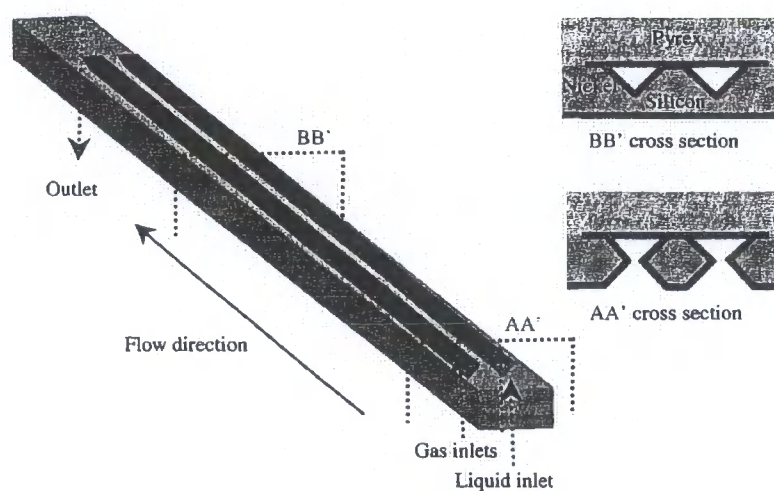

Fig 4.21: Shows a diagram of the two parallel nickel lined reactor channels

A microreactor for the direct fluorination of 4-benzylpyridine has been reported by Scuppich,¹⁷¹ the design being similar to the one described in section 4.5.2, figure 4.13. However, the microreactor is constructed from a nickel/ copper alloy and the reactor channels have a cross-sectional area of 0.05mm by 0.05mm. Fluorination of 4-benzylpyridine was found to give the 2-fluoro derivative in a moderate yield (50%), as shown in figure 4.22.

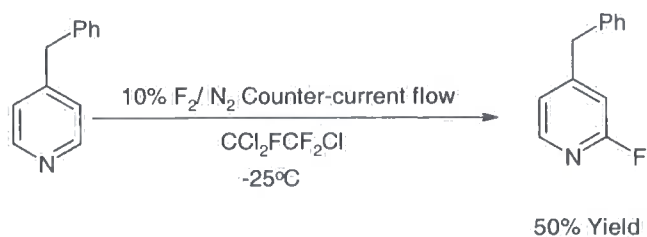

Fig 4.22

Guber has described a microreactor for IR in-line monitoring of the reaction between silicon tetrachloride and fluorine (See Fig 4.23).¹⁶⁸ The reactor was fabricated from stainless steel and the observation windows from AgCl, as shown in figure 4.24. The reaction could be measured along the length of the channel (5mm) and a profile for the formation of SiF₄ could be determined.

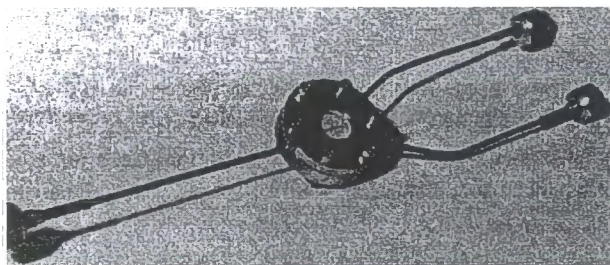

Fig 4.23



Fig 4.24

4.6 Chapter 4.0 Summary

Microreactor technology presents a new important methodology for chemical synthesis. Benefits include improved reaction efficiency, waste minimisation, lower financial investment, improved safety, increased controllability, and theoretically infinite scale-out. Moreover, microreactor technology offers on-site production and may open up new avenues of chemical supply, especially in remote areas, or where presently used conventional methodology is not financially viable.

Microreactor technology also offers the ability to rapidly screen reaction conditions and hence quickly ascertain optimum conditions. As a result, time to market from initial concept is also substantially reduced and thus patent life is effectively extended.

Chapter 5.0: Direct Fluorination Microreactor Design

5.1 Introduction

Direct fluorination using microreactor technology has been proved in concept by Chambers and Harston.^{164, 170} However, substantial development is required before direct fluorination microreactor technology can be applied to commercial applications. Consequently, we will discuss the design of several direct fluorination microreactors under the general aim of scale-out. It should be pointed out that while this project has been in progress, several other halogenation microreactors have been developed as described in chapter 4, and where relevant these alternative microreactors will be discussed along side those developed herein.

5.2 Design of the Three-Channel Microreactor (V-19)

To prove the concept that direct fluorination microreactors can be scaled-out, a microreactor possessing three parallel channels was designed and fabricated (See figs 5.1-5.5). The channels were of an identical cross sectional area, as compared with the single channel microreactor described previously by Chambers and Harston,^{164, 170} although the length of the channels is slightly shorter due to the block of nickel obtained being smaller. Nickel was chosen as reactor material due to the fact that nickel forms a protective passive layer of nickel fluoride when exposed to fluorine, and also displays good resistance to methanoic acid.²⁷² Fabrication of the V-19 was achieved using analogous techniques to the single channel microreactor. Channels were fabricated using a slitting saw, while the rest of the fabrication utilised conventional techniques, as described in chapter 4, section 4.5. To ensure a good seal between the polytrifluorochloroethylene (PTFCE) and the nickel block, the surface of the nickel was highly polished to provide a smooth surface.

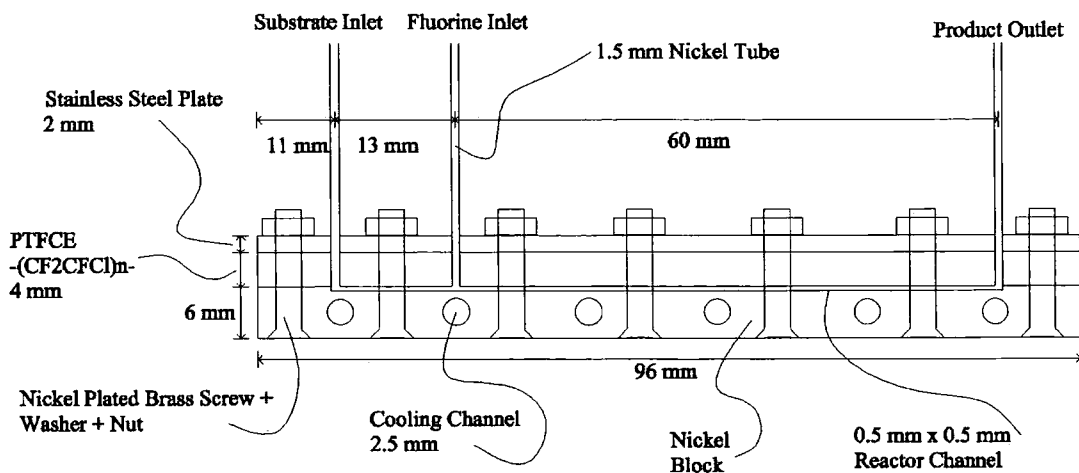

Fig 5.1: Side view of the V-19

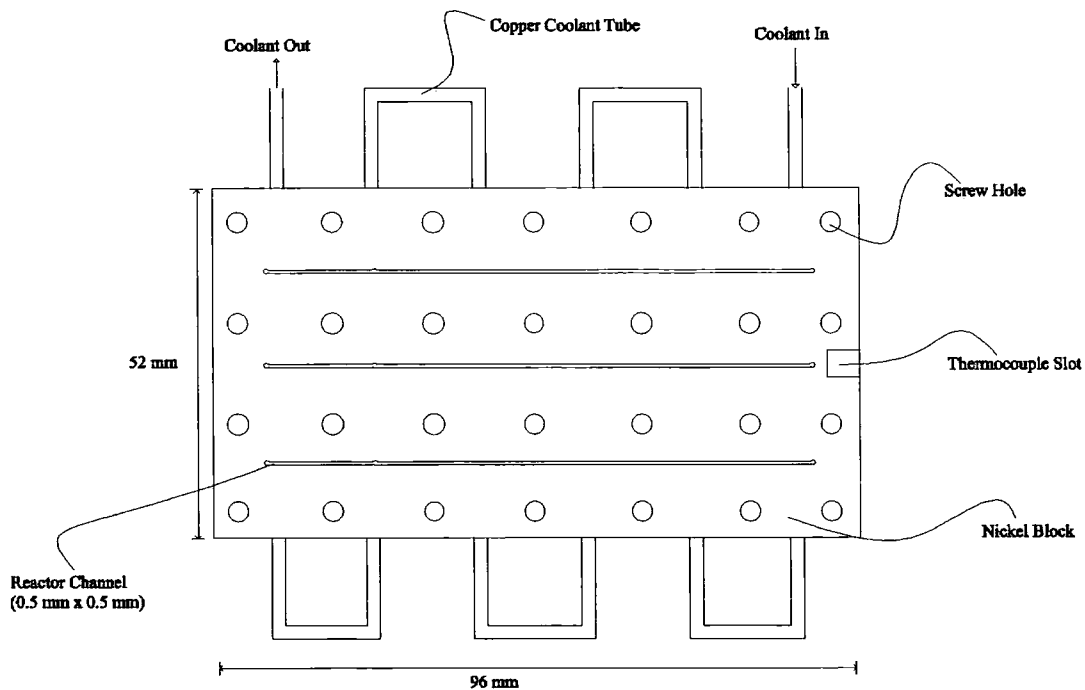

Fig 5.2: Top view of the V-19; PTFCE sheet, stainless steel top plate, and screws not shown for clarity

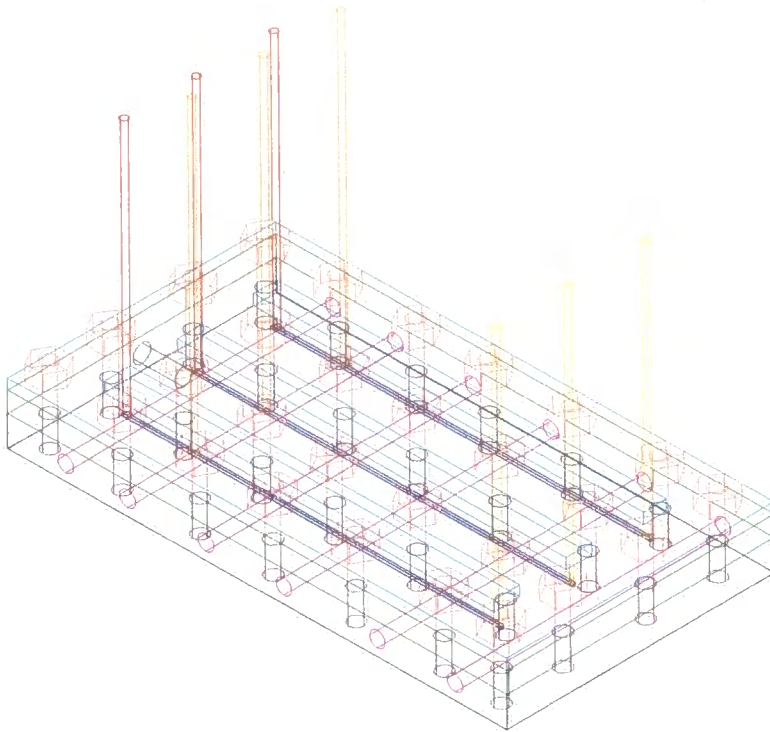
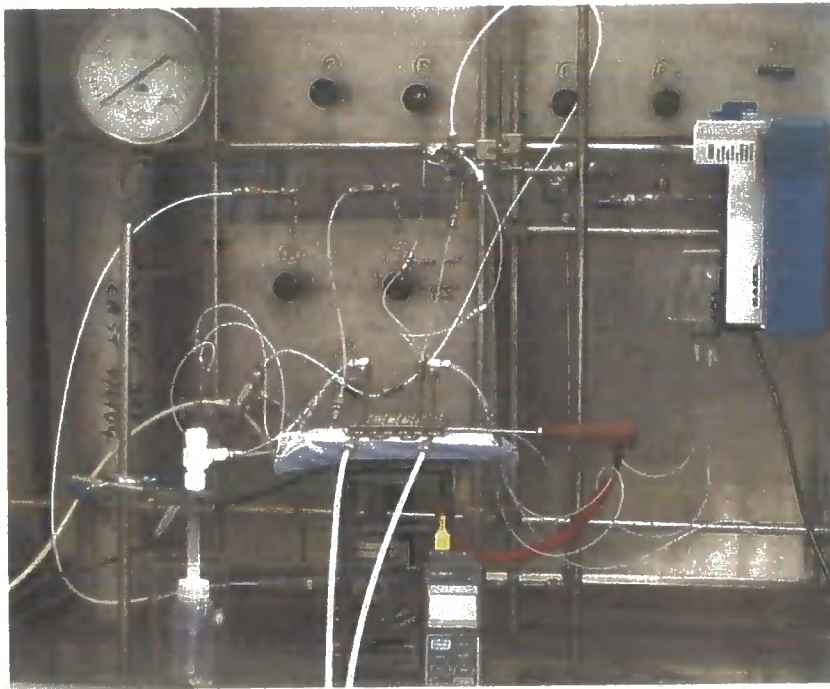
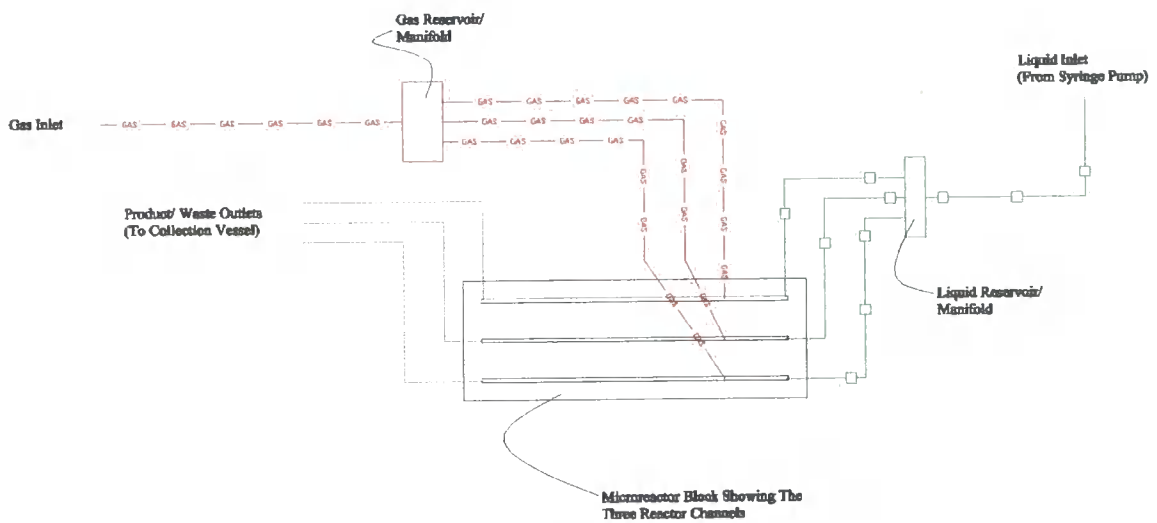

Fig 5.3: Three-dimensional wire frame view of the complete V-19; external copper cooling tubes not shown for clarity



(a)



(b)

Fig 5.4: (a) V-19 operational set-up (before use of external gas and liquid manifolds), and (b) schematic of V-19 operational set-up with external manifolds

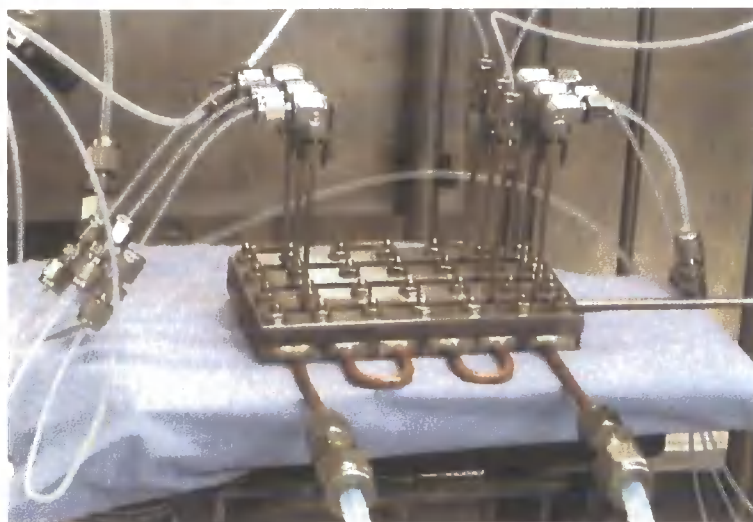

Fig 5.5: A close-up view of the V-19 in operation

Gas and liquid supply to the single channel microreactor^{164, 170} was accomplished without significant difficulty, and measured amounts of gas and liquid reagents could be metered to the channel with high accuracy. However, equal gas and liquid distribution to each of the three channels in the V-19 microreactor is inherently more difficult, due to the need for equal flow to each of the three channels. Distribution of the F_2/N_2 mixture was relatively simple and was achieved by dividing a singular gas flow into three separate sub flows using Swagelok[®] fittings. Tests with nitrogen had previously determined that the flow to each channel was identical. Testing involved the use of an inverted measuring cylinder filled with water. Gas flow from each of the three channel outlet tubes was separately bubbled into the water filled cylinder underwater, whereby the water would be displaced from the cylinder by the nitrogen. The time taken to fill the cylinder was found to be identical, hence gas flow was identical.

Distribution of the liquid reagent equally to each of the three channels posed more of a challenge, and initially, liquid was dispensed to each channel from a separate syringe operated by a syringe pump. Identical liquid flow to each channel was verified by collecting the liquid flow from each channel outlet tube into three separate receiving vessels. The volume collected for the same time period was found to be identical in each receiving vessel, hence liquid flow was identical. This practice of using three separate syringes was found to be cumbersome, and so an external liquid reservoir/ manifold

system was designed, as shown in figure 5.6a, which enabled easier operation. Liquid flow was now derived from one large syringe operating at three times the flow rate, until liquid enters the manifold where it was subsequently divided into three equal flows, verified as previously described. Liquid entry from the syringe to the manifold was located on the underside of the manifold to prevent gas pockets from forming, while liquid exit from the manifold to the channels was located on the upper side of the device. A similar manifold was fabricated for F_2/N_2 distribution, and replaced the one constructed from Swagelok[®] fittings, and is depicted in figure 5.6b.

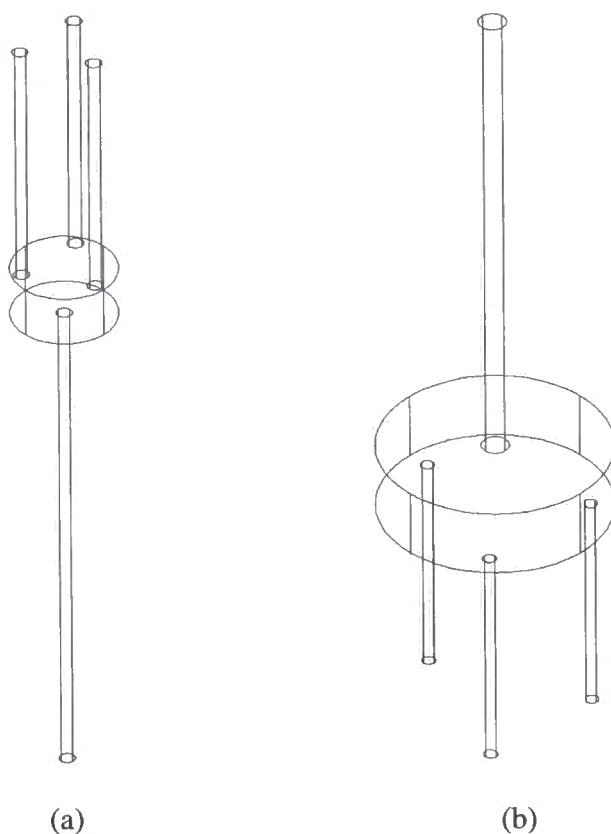

Fig 5.6: (a) Liquid manifold, (b) Gas manifold

Operation of the V-19 microreactor involves using pre-diluted fluorine (10% in nitrogen v:v) at a pressure of one bar typically at a flow rate of $10\text{mlmin}^{-1}\text{ch}^{-1}$; liquid flow through the microreactor is generally less than $8\text{mlh}^{-1}\text{ch}^{-1}$. Liquid enters the microreactor at a predefined rate through the liquid inlet tubes, while simultaneously, gas enters the

microreactor at a predefined rate through the gas inlet tubes as shown in figure 5.1. After coming into contact, gas and liquid pass through the reactor channel and both exit the microreactor through the product outlet tubes which then lead to the collection device as shown in figures 5.7a and 5.8a.

Unfortunately, during operation, blockage problems occurred where the starting material and/or products were solids. The source of the blockage was found to be at the product outlet nozzles, which are located in the collection vessel. Due to the fact that a small volume of liquid flows through each channel ($<8 \text{ mlh}^{-1}\text{ch}^{-1}$) relative to a large excess of the F_2/N_2 gas mixture ($600 \text{ mlh}^{-1}\text{ch}^{-1}$), crystallisation of material at one or more outlet nozzles occurred as a consequence of solvent evaporation. Consequently, uneven distribution of gas and liquid were observed, and in some cases led to the development of secondary blockages within the microreactor channels. To prevent this problem from occurring a simple nozzle cleaning device was designed and subsequently used in reactions involving solid reagents and/ or products, as depicted in figures 5.7b and 5.8b. Blockages were prevented by supplying extra solvent to the outlet nozzles thereby dissolving any crystallised material. The device was constructed by the addition of a PTFCE tube to the original collection device, through which solvent was secreted just above the outlet nozzles. It should be pointed out, that the product outlet tubes are required to touch the end of the PTFCE nozzle in order for the extra solvent to run down to the product outlet nozzles.

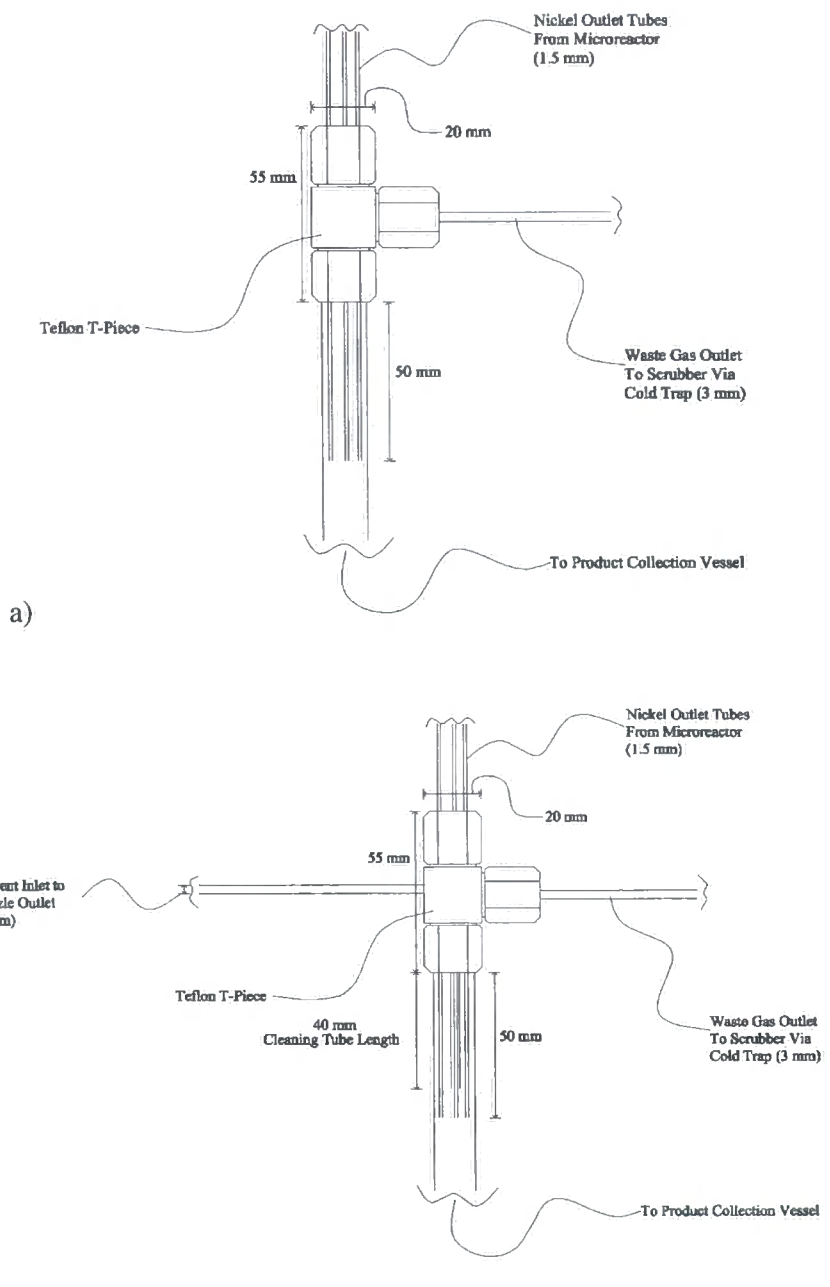

Fig 5.7: (a) Side view of the product collection device; (b) Side view of the nozzle cleaning/ product collection device

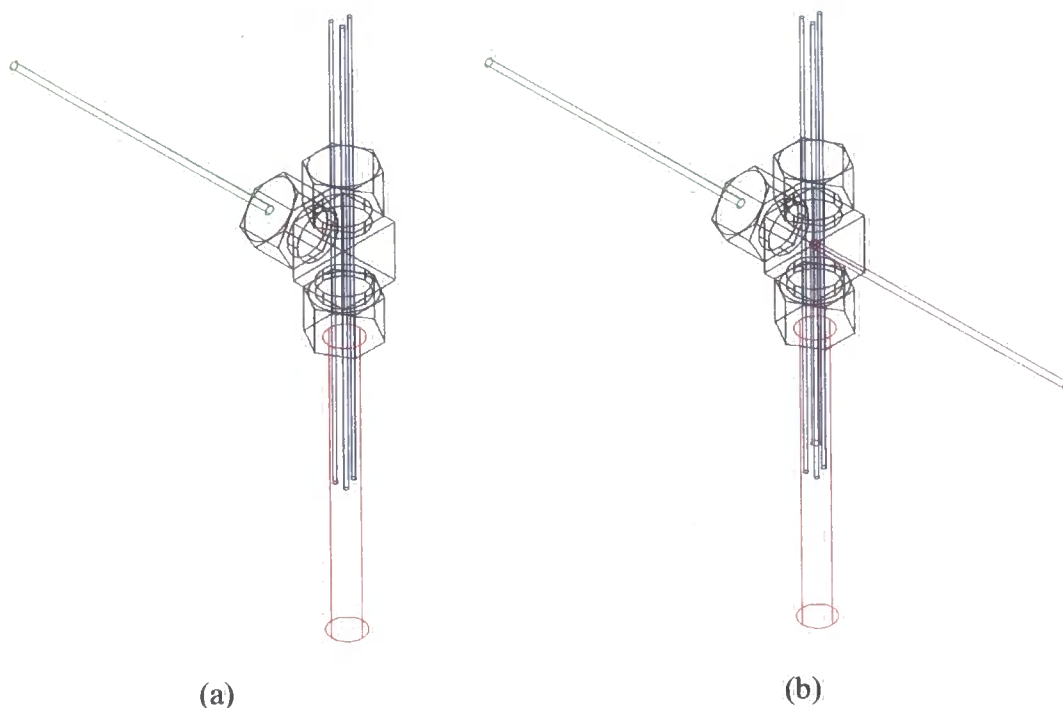

Fig 5.8: (a) Three-dimensional wire frame view of the product collection device, and (b) the nozzle cleaning/ product collection device (Extra solvent supply tube shown in purple)

Critical analysis of the V-19 microreactor design allowed us to identify several problems which require solving, so that scale-out becomes a simpler process, problematic areas were:

- 1) The microreactor block and reagent solution are cooled to the desired reaction temperature, but the F_2/N_2 mixture enters the channel and is allowed to come into contact with the liquid phase at ambient temperature (depicted in figure 5.1), which may cause hotspot formation and hence, for example, product degradation.
- 2) The reactor, manifolds, and collection device are separate entities; consequently, the device is complicated and requires the presence of numerous tubes, which enables all the separate pieces to be linked together, as shown in figure 5.4.

- 3) Nickel inlet/ outlet tubes enter through the PTFCE sheet, and as such, they are not very rigid. Moreover, scale-out would require a large number of these tubes, three per channel, which is not practical.
- 4) The number of channels allowed per unit is not maximised, as only one side of the block surface is used.
- 5) The radii of the slitting saw has to be accommodated at the ends of the channel, which results in channels with slightly rounded ends.²⁹¹ Moreover, the slitting saw is also known to wander slightly in all but very soft materials, and so there will be a significant tolerance in the channel width.

These problems were addressed and as a result, the twelve-channel microreactor was developed and is discussed in the next section.

5.3 Design of the Twelve-Channel Microreactor (V-20)

As described in the last section, several improvements were necessary to the design of the V-19 microreactor, and consequently the V-20 microreactor was developed (See Figs 5.9-5.12).

Problems one, two, and three as described previously, were solved together by the design of a microreactor in which the gas, liquid, and product collection reservoirs were incorporated within the microreactor block. Gas and liquid reservoirs are large to enable the equal distribution of reagents to the channels. However, the product reservoir (or collection point) is significantly smaller because a large reservoir is not required for this purpose. Stainless steel was used as the block material, since it provides a cost effective alternative to nickel in this case due to the relative high cost of using nickel for this purpose. Holes were machined from the respective reservoirs to the channels by the EDM drilling (See Chapter 4, section 4.5.3) of 0.5mm diameter holes, as shown in figure 5.13b.

Problem four was solved by using both sides of the reactor which doubles the number of channels that can be fabricated into one device. Although consequently, the reactor must now to be operated in a vertical position as opposed to a horizontal position. However, a direct benefit of vertical operation is that the gravity effects observed in

horizontal gas-liquid flow are now eliminated (See chapter 4, sections 4.3.1.1 and 4.3.1.2).²⁷⁴

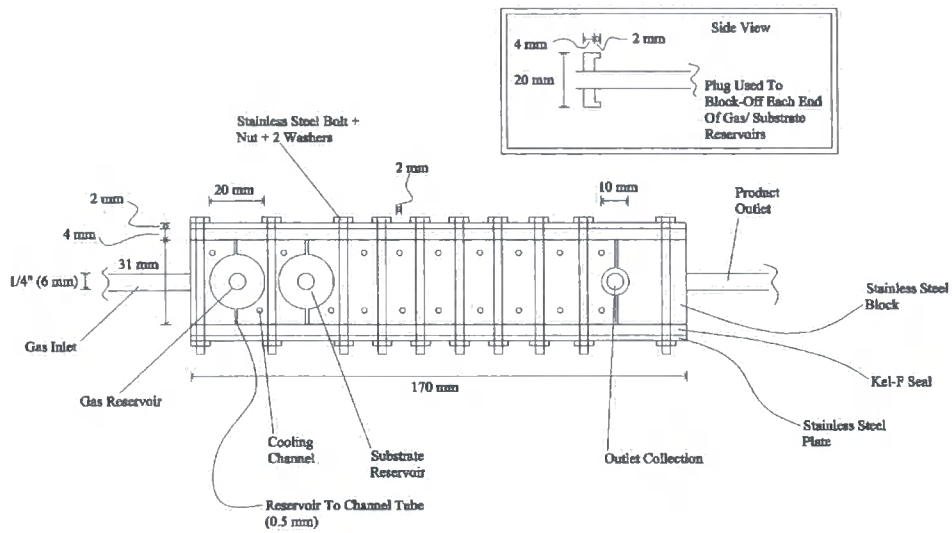

Fig 5.9: Side view of the V-20 in a horizontal position; the operational position is vertical

Hashed Lines Indicate Position Of The Lower
Coolant Tubes Which Are In A Different Position
Compared To The Ones Above

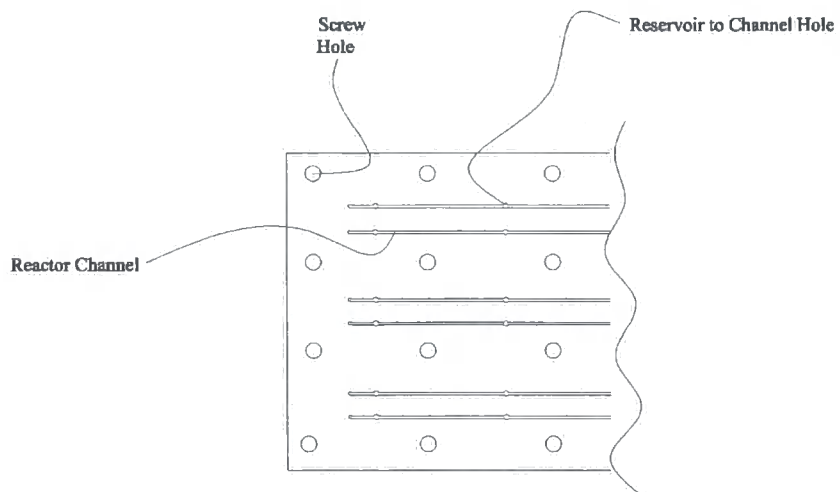
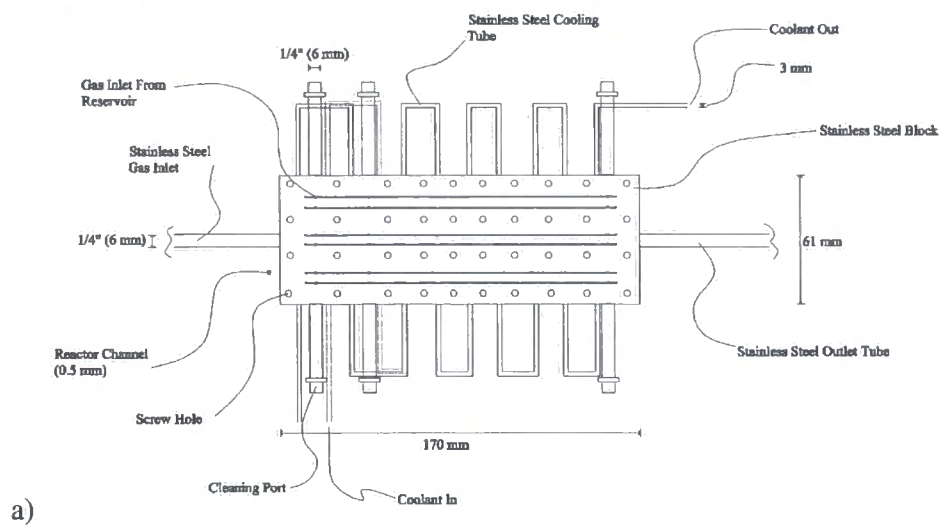

Fig 5.10: (a) Top view of the V-20 in a horizontal position; both sides of the reactor are identical (Six reaction channels per side) and (b) expanded section showing the reservoir to channel holes

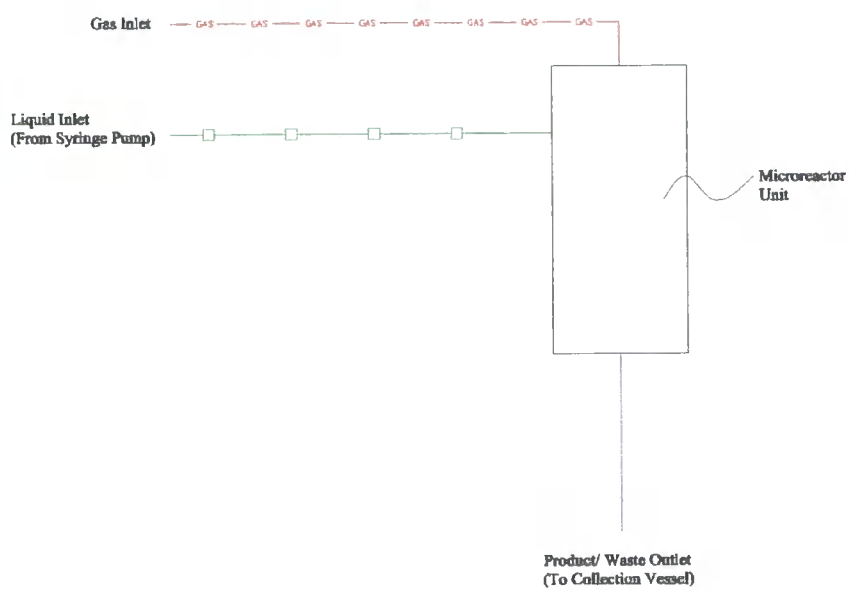
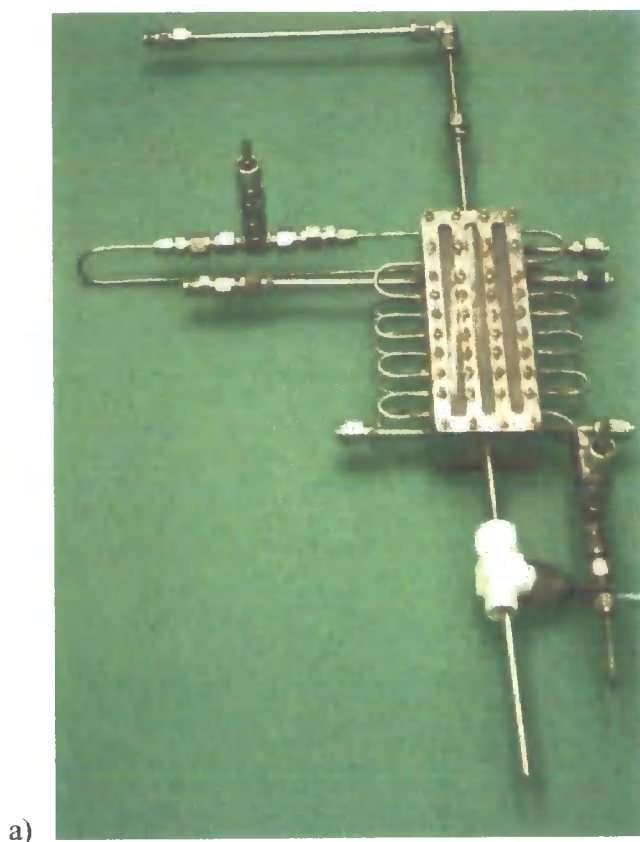

Fig 5.11: (a) Complete V-20; gas inlet located at the top, liquid inlet located on the left, and product outlet located at the bottom, of the photograph; (b) schematic of the V-20 (use of internal gas and liquid manifolds)

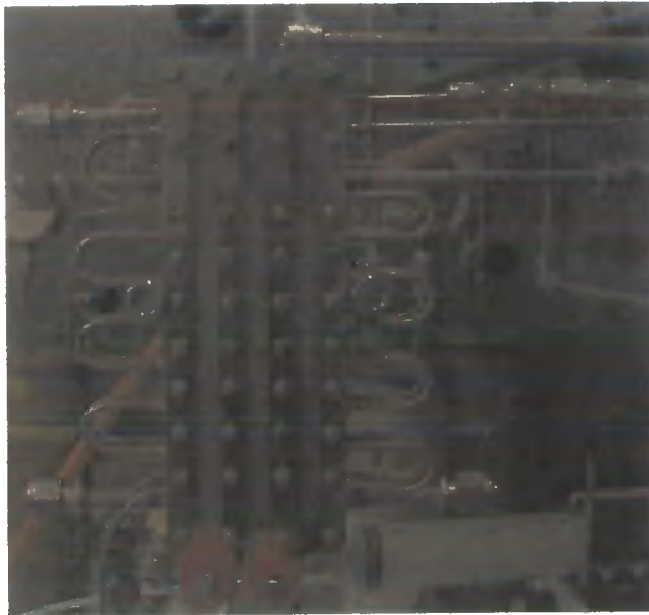
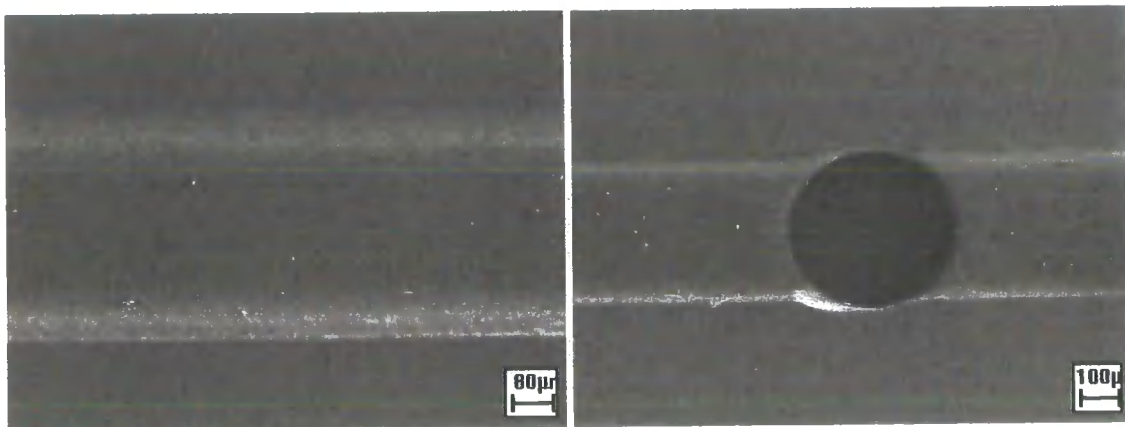

Fig 5.12: V-20 microreactor in vertical operational position

Problem five was solved by the use of an alternative fabrication technique, namely wire EDM. Wires of a highly accurate diameter can be drawn, and hence the accuracy of the channel is correspondingly increased, in fact the accuracy of fabrication using a conventional wire EDM machine is $\pm 0.02\text{mm}$ or 4% (See Fig 5.13a).



(a)

(b)

Fig 5.13: (a) 0.5 by 0.5mm V-20 microreactor channel fabricated using wire EDM; (b) 0.5mm diameter reservoir to channel hole, fabricated by EDM drilling

Preparation of the V-20 prior to operation involves cooling the reactor to the reaction temperature and filling the liquid reservoir with reagent solution. During operation, the reagent solution is continually fed into the liquid reservoir at a pre-determined rate ($<8 \text{ mlh}^{-1}\text{ch}^{-1}$). Simultaneously, gas is fed into the gas reservoir at a pre-determined rate (pre-diluted fluorine (10% in nitrogen v:v) at a pressure of one bar, typically at a flow rate of $10 \text{ mlmin}^{-1}\text{ch}^{-1}$). Both phases are distributed into twelve separate flows and are passed into the reaction channels, where they come into contact and subsequently pass into the product collection reservoir prior to leaving the device through the product outlet tube.

Unfortunately, during operation and maintenance, several significant design defects were soon realised, these were:

- 1) The channels are fabricated into the block, and should corrosion result in the channels, the block will require replacing which can only be accomplished at a relatively high cost.
- 2) The number of channels in the block cannot be changed rapidly, since extra channels can only be added by further EDM machining. Furthermore, a decrease in the number of channels would be impossible.
- 3) The liquid to channel hole was located in the wrong position. It was observed that due to the hole being located in the middle of the reservoir, as shown in figure 5.14, a gas pocket was created within the reservoir and hence liquid flow to the channels was uneven.
- 4) Maintenance of the V-20 proved troublesome and the screw fastening mechanism did not allow the independent removal of one side of the device since the screws pass completely through the block; consequently, maintenance was time consuming.

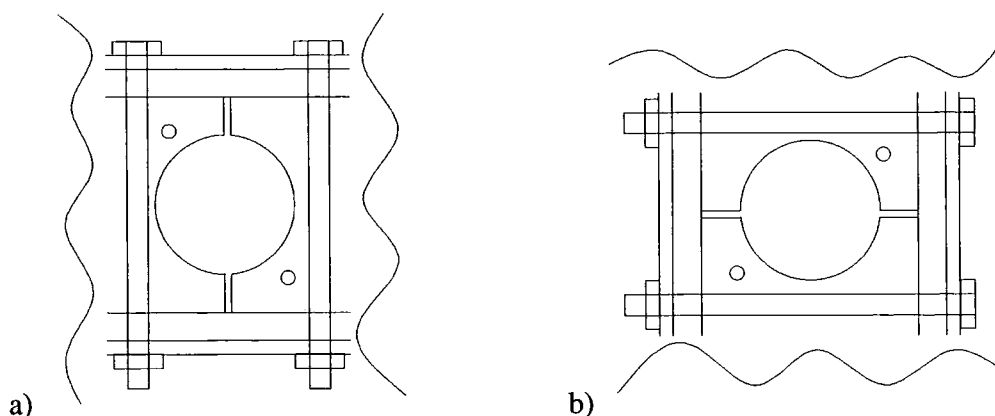

Fig 5.14: V-20 microreactor liquid reservoir (a) in a horizontal position and (b) in a vertical position; gas pocket observed

These design issues were investigated and subsequently solved; these solutions are described in the next section.

5.4 Design Of the Multi-Channel Microreactor (V-21)

As described in the last section, several design improvements needed to be made to the V-20, which has led to the development of the V-21 (See Figs 5.15-5.19).

Problems one and two were solved together by designing a detachable multi-channel system. Channels are created by three plates, namely a bottom plate, a channel plate (or middle plate), and a top plate, which are then sealed together, as shown in figures 5.20 and 5.22. The V-21 block acts only as the heatsink and distribution manifold in this design. Moreover, the plates are relatively cheap to produce relative to the cost of the block, and hence if significant corrosion of the channels occurs, then these plates can be simply removed and replaced. Furthermore, using this system the number of channels can be changed rapidly by selecting the appropriate channel plate (See Figs 5.23-5.26). It should be pointed out that in our research design the top plate was constructed from PTFCE, however in a fully working model, this plate can be fabricated from metal, e.g. nickel or stainless steel. The reason for using PTFCE is that the visual observation of the channels can be made.

Nonetheless, to allow this design change to be realised, the reservoir to channel holes as described in the last section, had to be replaced with one large slot to allow this

flexibility. Hessel and Jähnisch^{166, 169} have also described the use of one large slot for the distribution of a liquid phase into many reaction channels, although the precise location of the slot relative to the reservoir was not disclosed, but presumably it is located in a similar position to the one in the V-21 microreactor.

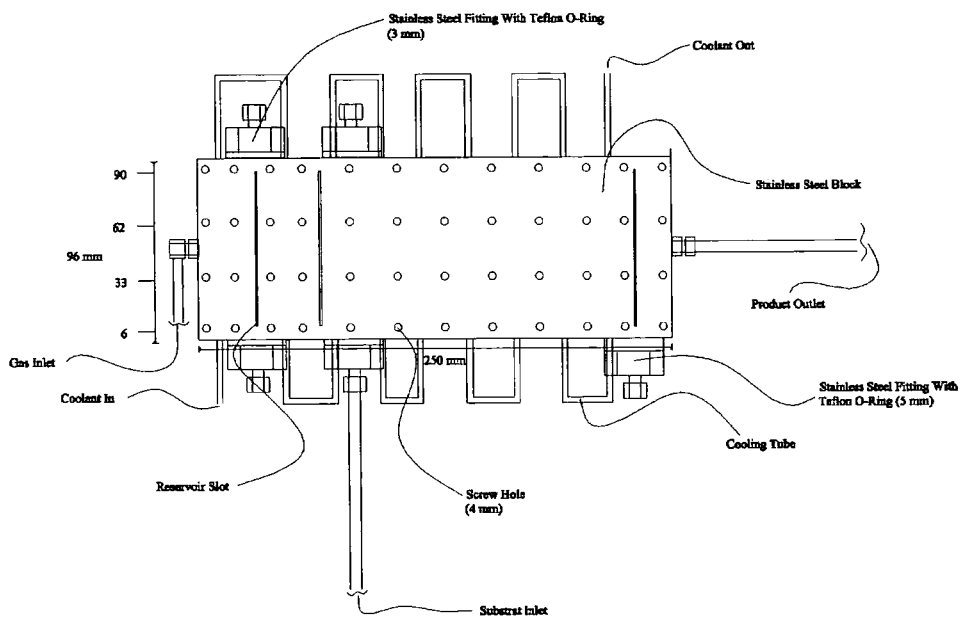

a)

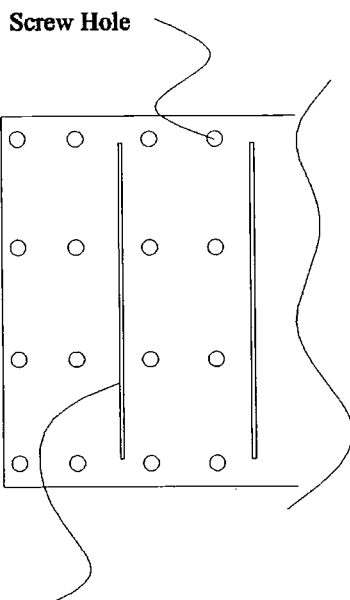

b) Reservoir Slot

Fig 5.15: (a) Top view of the V-21 in a horizontal position and (b) expanded section showing the reservoir to channel slots

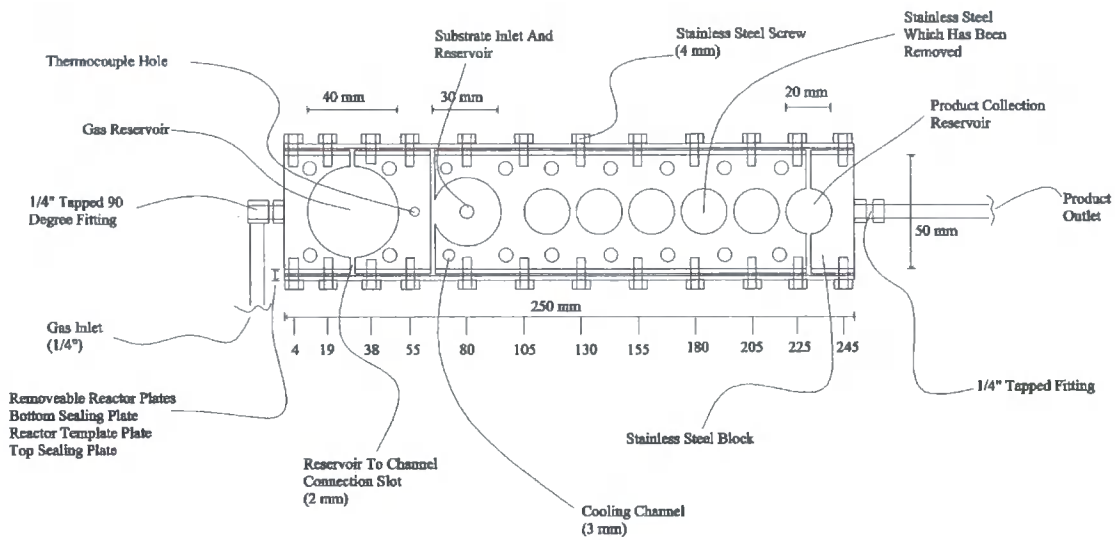

Fig 5.16: Side view of the V-21 showing the relative positions of the reservoir to channel slots

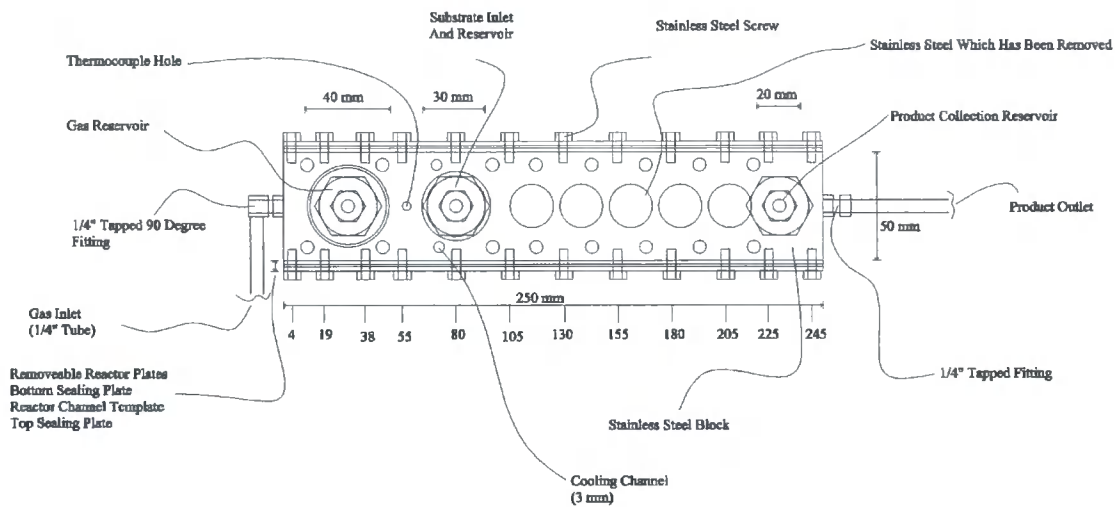

Fig 5.17: Side view of the V-21 with attached Swagelok® fittings

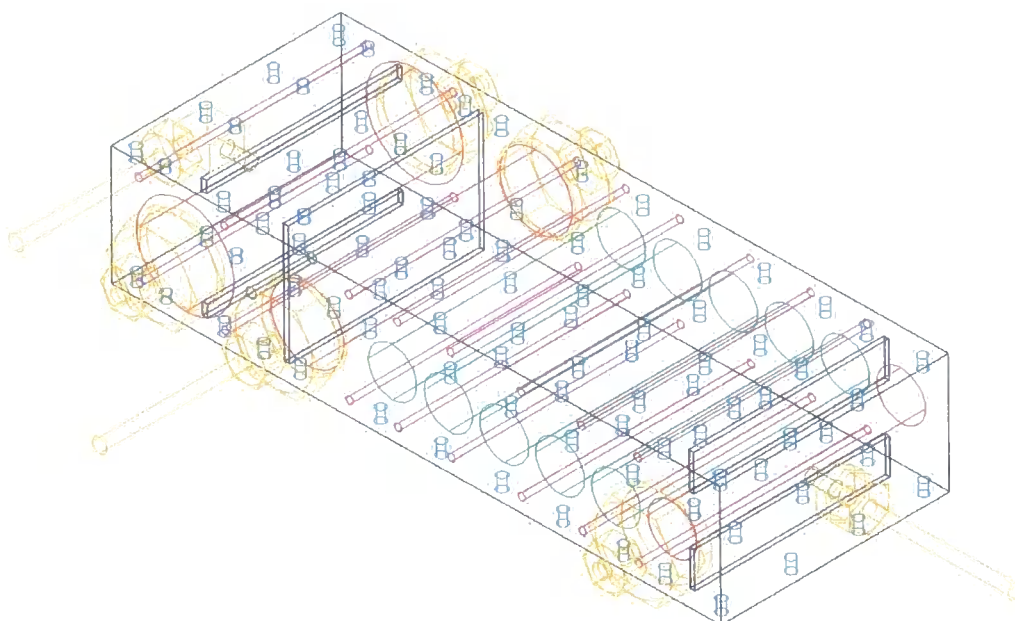

Fig 5.18: Three-dimensional wire frame view of the V-21; external cooling tubes are not shown for clarity

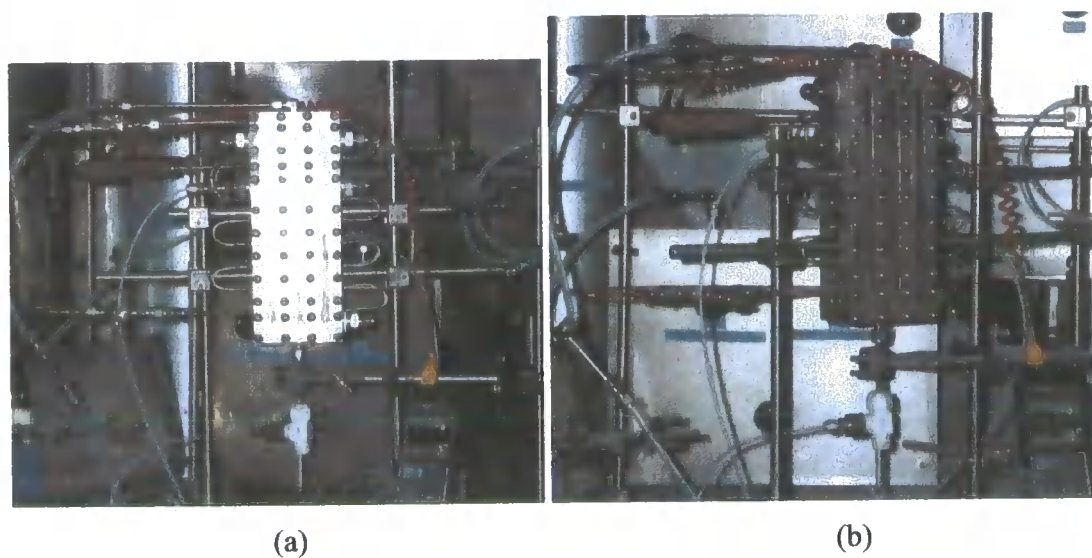

Fig 5.19: The V-21 in operational position; (a) front view, (b) front-side view

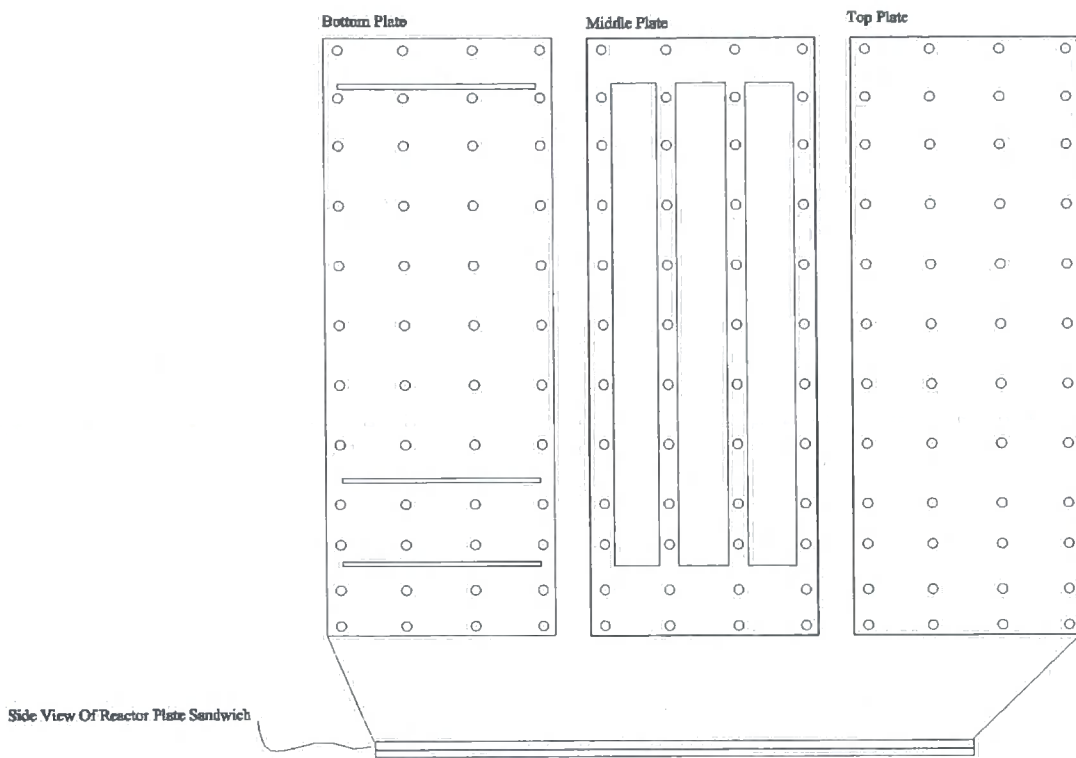

Fig 5.20: General diagram of the three plate channel system

Problem three was solved by locating the liquid reservoir to channel slot at the far left of the reservoir as drawn horizontally, as opposed to in the centre, (compare figures 5.14 and 5.21), so that when the V-21 is in its vertical operating position, this slot is located at the top of the reservoir, and hence gas pockets cannot form.

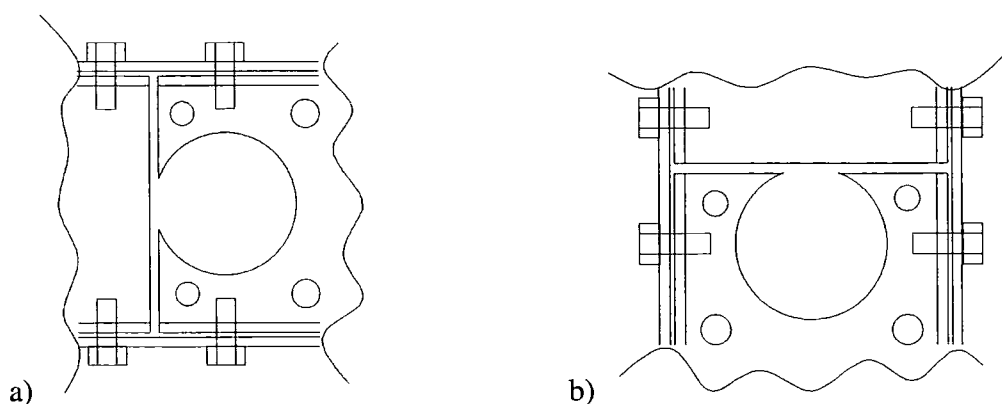

Fig 5.21: V-21 microreactor liquid reservoir (a) in a horizontal position and (b) in a vertical position; no gas pocket observed

Problem four was solved by the independent attachment of each set of channel plates to the side of the block, which allows the simple removal of each set of plates when desired.

Due to the fact that the stainless steel block and the nickel bottom plate are relatively hard materials, sealing between them was unsatisfactory; therefore we used a thin gasket to improve sealing. Copper was our first choice as it is known to be resistant to fluorine.²⁹² The use of a copper gasket completely sealed the device, however the methanoic acid solution and/ or the HF was found to corrode the copper gasket while in use, and as a result further secondary corrosion was observed on the nickel bottom plate a consequence of the copper ions catalysing the corrosion of the nickel.²⁹³ The use of copper as gasket material was therefore ruled out. Lead was tested as an alternative material, however rapid corrosion was also observed. We next turned our attention to PTFE as gasket material, since PTFE is known to have excellent fluorine, methanoic acid, and HF resistance properties. Only one problem with PTFE was envisaged regarding its poor thermal conductivity, which could pose as a barrier to the efficient heat transfer in the microreactor. Contrary to our predictions, as will be discussed in the next chapter, we observed no detrimental effects on product selectivity. Hence, PTFE gaskets have been used in all V-21 microreactor experiments. (The hierarchy of plate attachment to one side of the V-21 microreactor block is shown in figure 5.22.)

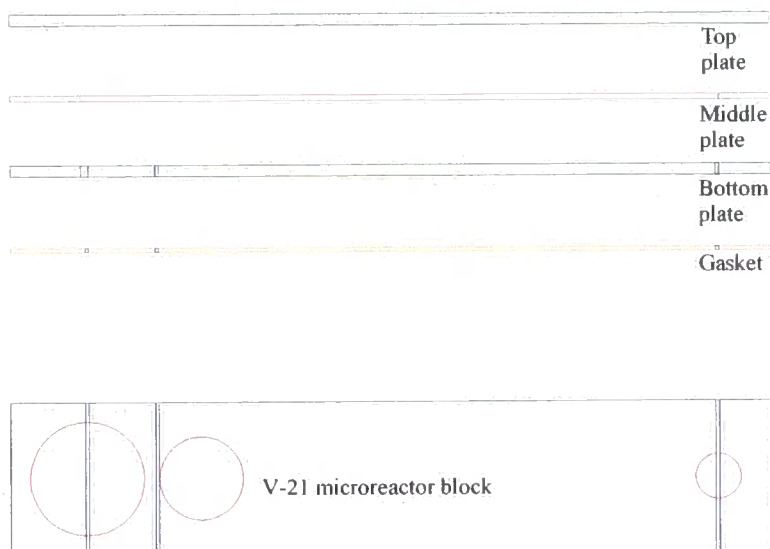
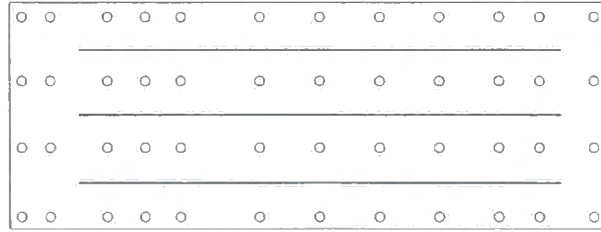

Fig 5.22: Hierarchy of plate attachment

Several different channel plates were fabricated, simultaneously by chemical etching (See Chapter 4, Section 4.4.4), and can be seen in figures 5.23-5.26. Plates possessing three, nine, and thirty channels were found to be rigid structures, however the channel plate possessing fifty-seven channels was not found to be structurally rigid and in fact resembled the strings of a harp, or that is to say that the separating metal between the channels distorted somewhat upon the appliance of a small force. Laser fabrication was also investigated (See Chapter 4, Section 4.4.5), however, heat generated during the process was found to distort the adjacent channels when the metal separating the channels was 0.5mm. Although whilst not investigated, if the distance between the channels is increased then laser fabrication of the channels may be possible.

3 x 1 0.5 mm Slots



a)

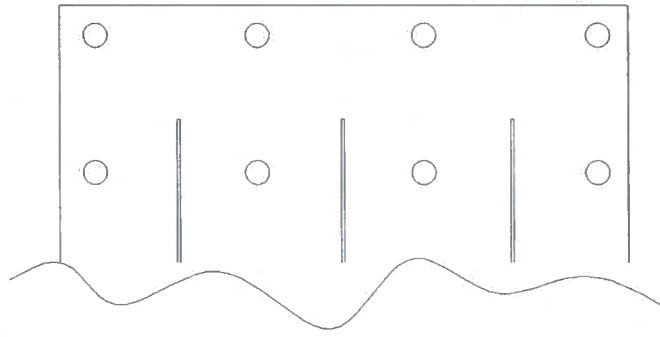

b)

Fig 5.23: Three channels per plate; (a) full plate and (b) enlarged end section

3 x 3 0.5 mm Slots
Separated By 3.5 mm

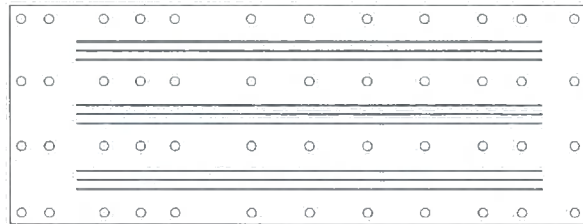

a)

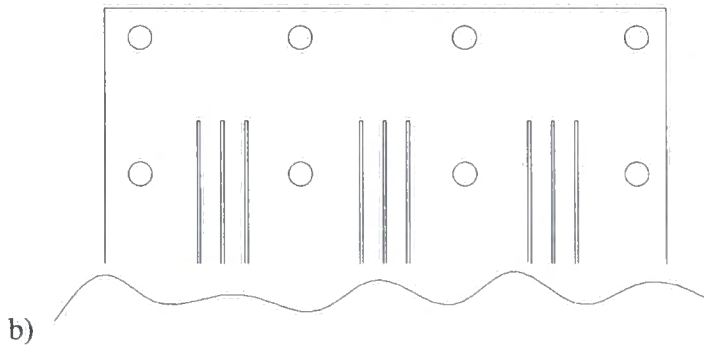

b)

Fig 5.24: Nine channels per plate; (a) full plate and (b) enlarged end section

3 x 10 0.5 mm Slots
Separated By 1.5 mm

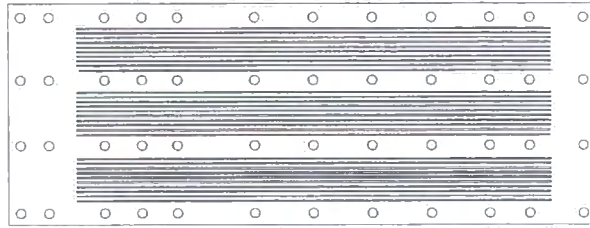

a)

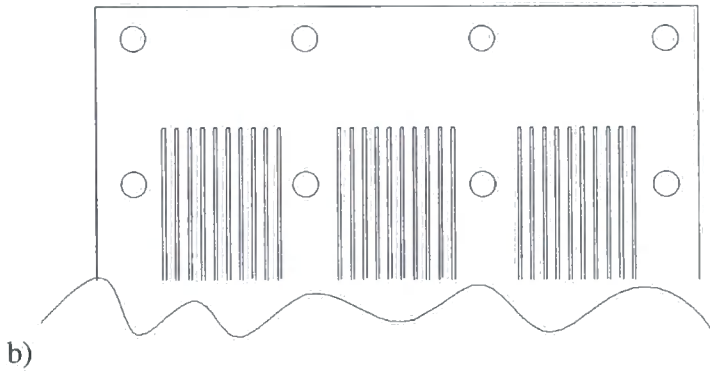

b)

Fig 5.25: Thirty channels per plate; (a) full plate and (b) enlarged end section

3 x 19 0.5 mm Slots
Separated By 0.5 mm

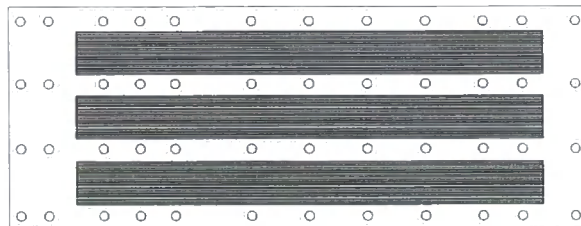

a)

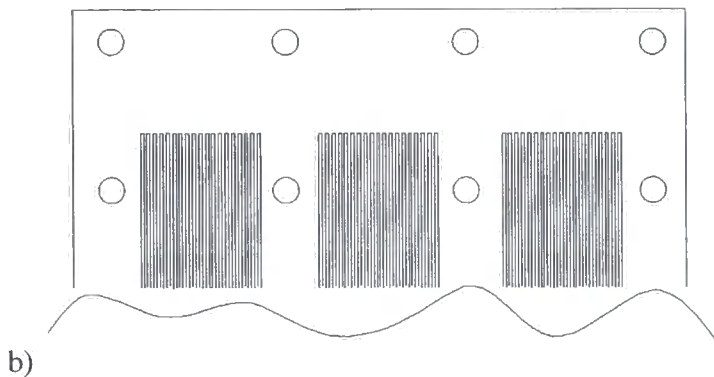

b)

Fig 5.26: Fifty-seven channels per plate; (a) full plate and (b) enlarged end section

Operation of V-21 microreactor involves an analogous procedure as compared with the V-20 (described in section 5.3), in that preparation of the V-21 prior to operation involves the selection of an appropriate channel plate, cooling of the reactor to the reaction temperature, and charging the liquid reservoir with reagent solution. During operation, the reagent solution is continually fed into the liquid reservoir at a pre-determined rate ($<8 \text{ mlh}^{-1}\text{ch}^{-1}$). Simultaneously, gas is fed into the gas reservoir at a pre-determined rate (pre-diluted fluorine (10% in nitrogen v:v) at a pressure of one bar, typically at a flow rate of $10 \text{ mlmin}^{-1}\text{ch}^{-1}$). Both phases are distributed into separate flows by the channel plate where they come into contact and subsequently pass into the product collection reservoir prior to leaving the device through the product outlet tube.

The microreactor design reported by Hessel and Jähnisch^{166, 169} (Chapter 4, Fig 4.19) has some similarities to our design, however and analysis of their design reveals several potential problems to its long term use. These problems are: 1) fluorine and liquid enter the microchannel at room temperature, 2) the reactor template is very close to the reactor cooling channels and 3) the number of channels per block is not optimised.

The first concern is that of the fluorine entering the microreactor at room temperature, although it is well known that microreactors have favourable heat transport properties, it follows that the less heat that has to be removed from the system initially, the greater will be thermal control of the reaction and hence selectivity. In the Hessel and Jähnisch design, the gas and the liquid phases enter the microreactor un-cooled and meet un-cooled in a well cooled microchannel, the reagent gas in this case being fluorine, results in a highly exothermic reaction. It follows then that at the initial point of mixing, the heat exchanger has to remove not only the thermal energy of the reagents entering the microchannel, but also the exothermic energy of the reaction. It is clearly beneficial for the reaction therefore, that the heat exchanger removes only the heat of reaction as this would result in lower hotspot temperature, and hence an increase in selectivity. In fact, work discussed in the next chapter highlights this point.

The second concern relates to the reactor template, in that it is very thin, presumably to maximise heat transport across it to the heat exchanger fluid. During the current and previous work in this laboratories, it has been found the metal surface

corrodes slowly, one probable cause of this being the hydrofluoric acid generated during the reaction of fluorine with organic chemicals, although acidic solvents may also have an effect. Nevertheless, the corrosion has only been found to occur in the reactor channels where the fluorine and organic phase come into contact. The design described in the literature will therefore have potential problems relating to the life of the reactor, as corrosion of the reactor plate could cause heat exchange fluid to enter the microreactor where it is not desired. Our design (V-21) reduces this risk significantly, since the reactor plates are attached to a large cooled metal block of stainless steel, which acts as the heat sink. The reactor plates, and hence corrosion are located a significant distance away from the heat exchanger channels, and therefore the probability of heat exchanger fluid entering the reactor channels is zero. On the other hand, it may be argued that the reactor plates in the literature example may be replaced, however they will need to be replaced more often than those of our design, which is inconvenient. Moreover, there is also the chance that the reactor plate may fail earlier than expected, and therefore it is much safer to use our microreactor design.

The last concern is that of microreactor potential, as the literature example utilises only one side of a possible two sides. To improve the microreactor scale-out potential, our design (V-21) gives the option to utilise both sides of the stainless steel block, thereby effectively doubling the number of channels that can be constructed into one microreactor unit. Recently, Schuppich and Whele have also addressed this problem and have reported the design of a double sided microreactor system.^{171, 290}

5.5 Chapter 5.0 Summary

We have continually developed the concept of a direct fluorination microreactor from a single channel commercially unpractical device, to a scaled-out commercially useful reactor. Furthermore, the final design discussed in this thesis (V-21) has a large degree of flexibility regarding the number, shape, and material of the reactor channel plates, all of which can be changed easily by the simple attachment of an appropriate plate system. The V-21 microreactor has been designed to be a robust device so that little maintenance is required when in operation, which is advantageous for commercial application.

Chapter 6.0: Direct Fluorination of Organic Compounds Using Microreactor Technology

6.1 Introduction

It is well known that using conventional batch liquid phase fluorination methodology, the reaction between fluorine and an organic species occurs mainly at the gas-liquid interface, or that is to say in a heterogeneous manner.²⁹⁴ It has been suggested that increasing the solubility of fluorine in solvents, for example by the *in-situ* generation of reactive intermediates such as acetyl hypofluorite, could lead to the need for less drastic fluorination conditions.²⁹⁵ On the other hand, a more efficient use of fluorine could be achieved by increasing the gas-liquid interfacial area, or in other words, by increasing the surface area of the heterogeneous reaction.

Furthermore, controlling the highly exothermic nature of selectively forming a C-F bond from a C-H bond via direct fluorination has been a crucial development; diluting fluorine and substrate with relatively inert media or by the use of low temperatures, being established current methodology.⁶⁵ Improvements to this methodology are long overdue, and it follows that increasing the rate at which heat is transferred away from the reaction centre could potentially benefit a direct fluorination approach by reducing hotspot formation, and hence by-product formation and/ or product degradation.

Microreactor technology offers an ideal alternative to increasing the fluorine solubility, as microreactors can provide high interfacial gas-liquid contact areas, far higher than those achieved using conventional fluorination methodology.²⁶³ Moreover, the relatively small dimensions of microreactors ensures improved heat transfer away from the reaction centre, and allows much more control over the reaction temperature, as discussed in chapter 4.

Using this approach, we have investigated the potential of microreactor technology as an alternative fluorination methodology; the results of this study are discussed in this chapter.

6.2 Single Channel Microreactor

As discussed in chapter 4, section 4.5.3, Chambers and Harston^{164, 170} have utilised microreactor technology for the fluorination of 1,3-dicarbonyl compounds. Using the same single channel microreactor (See Fig 4.14), we have fluorinated several other related 1,3-dicarbonyl compounds (See Fig 6.1) with elemental fluorine and these results are presented in table 6.1. Products were identified by comparison to literature data,¹⁰⁶ and in each case, difluorinated derivatives accompanying the major monofluorinated product were present.

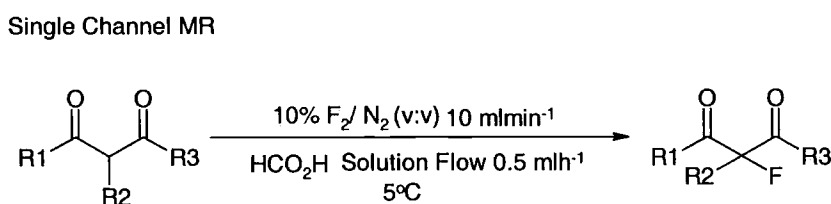

Fig 6.1

Table 6.1: Direct fluorination of 1,3-dicarbonyls using a single channel microreactor

1,3-Dicarbonyl	Substrate Flow [†] mmolh ⁻¹ (gh ⁻¹ of substrate)	Conversion ^a %	Mono-fluoro Product	% Yield ^a (gh ⁻¹ of product)
(70)	2.2 (0.29)	98	(71)	71 (0.23)
(74)	1.9 (0.27)	52	(75)	49 (0.08)
(77)	2.4 (0.31)	66	(78)	95 (0.22)
(80)	1.9 (0.27)	93	(81)	78 (0.22)
(83)	1.7 (0.29)	86	(84)	76 (0.21)

^a Determined by gc; [†] Flow of F₂/ N₂ equals 2.6 mmolh⁻¹

Conversions and yields for the microreactor were found to be similar or higher than those obtained using conventional batch fluorination methodology.¹⁰⁶ For example, using the aforementioned microreactor and only a slight excess of fluorine (1.2 equivalents), a 99% conversion of (70) and a 71% yield of (71) was achieved. By comparison, the direct fluorination of (70) using batch methodology with two equivalents of fluorine, resulted in a 60% conversion and an 80% yield of (71). Evidently, the microreactor performed more efficiently than the bulk phase fluorination. However, it should be noted that Chambers¹²³ has found that nickel (II) salts catalyse the fluorination of 1,3-dicarbonyl compounds, thus it is reasonable to assume that the surface of the fluorinated nickel reactor channel could also provide a catalytic affect. On the other hand, the effect of increased heat and mass transfer (i.e. mixing) upon the reaction cannot be ignored, since we are effectively reacting within the microreactor channel, one equivalent of dicarbonyl compound with 1.2 equivalents of fluorine instantaneously. By comparison to the bulk fluorination process, and by taking into account the improved heat and mass transfer and low inventory of reagents within the microreactor channel, one can conclude that direct fluorination using microreactor technology is a much safer method of selectively introducing fluorine into organic compounds.

Using the single channel microreactor, the un-optimised hourly production rate of monofluorinated 1,3-dicarbonyl derivatives lies between 0.08-0.23gh⁻¹. This small amount of product, while being satisfactory for laboratory scale production, from a commercial point of view, the mass of material per hour is unsatisfactory. Consequently, the fact that microreactors may be scaled-out led to the development of a three channel microreactor (V-19), (as discussed in chapter 5, section 5.2) which theoretically should provide three times the through-put of the single channel microreactor. The direct fluorination results of this scaled-out reactor will be discussed in the next section.

6.3 V-19 Microreactor (Three Channel Microreactor)

6.3.1 1,3-Dicarbonyl Compounds

As previously mentioned, the V-19 microreactor was designed (chapter 5, section 5.2) to increase the throughput of material. Direct fluorination of several 1,3-dicarbonyl

compounds using the three channel microreactor resulted in the formation of monofluorinated derivatives as shown in figure 6.2 and table 6.2.

Three Channel MR

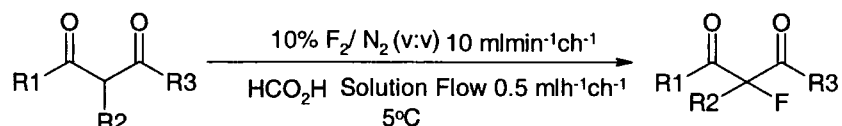
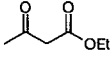
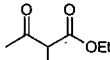

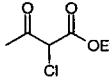

Fig 6.2

Operation of the V-19 microreactor under conditions similar to the single channel microreactor resulted in consistently lower conversions, although yields of the desired monofluorinated products were generally higher. These results can be explained by stressing that the channels of the V-19 microreactor are shorter than the one used in the single channel microreactor. Thus, the residence time within the microreactor is reduced and consequently, the extent of reaction is affected likewise. Product selectivity increases due to lower product degradation/ by-product formation within the reactor. Lengthening the outlet tubes of the reactor, which increases the residence time within the microreactor apparatus, increases the conversion of dicarbonyl compounds. Unfortunately however, the yield of monofluorinated derivatives decreased. One potential reason for the decrease is that the outlet tubes are not cooled, and hence hotspots could potentially form in these areas, thereby causing undesired fluorination/ product degradation.

Table 6.2: Direct fluorination of 1,3-dicarbonyls using three channel microreactor

1,3-Dicarbonyl	Temp. °C	Substrate Flow [†] mmolh ⁻¹ ch ⁻¹	Total Substrate Flow mmolh ⁻¹ (gh ⁻¹ of substrate)	Conv. ^a %	Mono-fluoro Product	% Yield ^a (gh ⁻¹ of fluoro product)
 (70)	18	2.1	6.3 (0.82)	53	(71)	87 (0.43)
	5	2.1	6.3 (0.82)	66		71 (0.44)
	5	2.1	6.3 (0.82)	57		87 (0.46)
	5	2.1	6.3 (0.82)	77		87 (0.62)
	5	2.1	6.3 (0.82)	91 ^ξ		65 (0.55) ^ξ
	0	2.1	6.3 (0.82)	79		94 (0.69)
	0	2.1	6.3 (0.82)	70		96 (0.63)
 (74)	5	2.0	6.0 (0.84)	47	(75)	38 (0.17)
	5	0.8	2.4 (0.35)	67 ^ξ		40 (0.10) ^ξ
 (83)	5	2.0	6.0 (0.84)	53	(81)	75 (0.38)
	5	1.5	4.5 (0.63)	95 ^ξ		67 (0.45) ^ξ
	5	1.9	5.7 (0.80)	99 ^ξ		65 (0.58) ^ξ
 (85)	5	0.9	2.7 (0.44)	59 ^ξ	(86)	74 (0.22) ^ξ

^a Determined by gc; [†] Flow of F₂/ N₂ equals 2.6 mmolh⁻¹ch⁻¹; ^ξ Reaction performed by using 50mm longer outlet tubes

6.3.2 Aromatic Compounds

Fluorinated aromatic derivatives are compounds of considerable importance. Therefore, to further highlight the potential of microreactor technology we have fluorinated some representative examples.

6.3.2.1 1-Methyl-4-nitrobenzene (87)

Direct fluorination of (87) (See Fig 6.3) under several reaction conditions was investigated using the V-19 microreactor, and the results are presented in table 6.3; products were identified by comparison to literature data.⁸¹ Fluorination of (87) in acetonitrile at room temperature ($<20^{\circ}\text{C}$) resulted in low conversion (15%), although a good selectivity for (88) was achieved (71%). Unfortunately, (87) was not found to be very soluble in methanoic acid (generally the solvent of choice for the fluorination of aromatic derivatives), and hence, an acetonitrile/ methanoic acid mixed solvent was used. Good conversions and yields were obtained using this solvent system; for example, at 5°C , with a flow rate of $2\text{mlh}^{-1}\text{ch}^{-1}$, using approximately three equivalents of fluorine, a substantially better conversion (53%) was observed, although the yield of (88) decreased slightly. Reducing the reaction temperature to 0°C , led to further improvements in conversion (53%), while the yield was relatively unaffected.

By comparison,⁸¹ conventional bulk liquid phase fluorination of (87) with two equivalents of fluorine, at 10°C in methanoic acid, gave a 63% conversion and a 50% yield of (88).

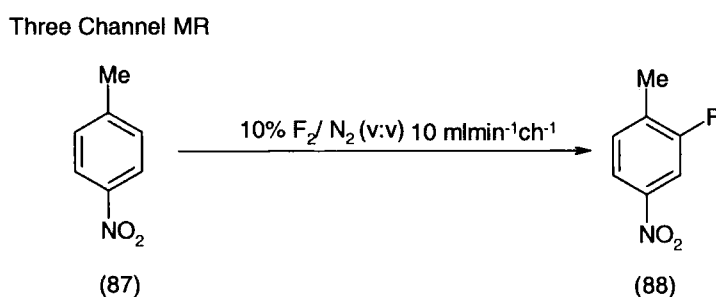

Fig 6.3: Flow of F_2/N_2 equals $2.6 \text{ mmolh}^{-1}\text{ch}^{-1}$

Table 6.3: Direct fluorination of 1-methyl-4-nitrobenzene (87) using a triple channel microreactor

Solvent	Temperature °C	Substrate Flow mlh ⁻¹ ch ⁻¹ (mmolh ⁻¹ ch ⁻¹)	Total Substrate Flow mmolh ⁻¹ (gh ⁻¹ of substrate)	Conversion ^a %	% Yield ^a of (88) (gh ⁻¹ of fluoro product)
MeCN	RT	2.0 (1.5)	4.5 (0.62)	15	71 (0.07)
3:2 MeCN/ HCO ₂ H	5	2.0 (0.9)	2.7 (0.37)	53	60 (0.13)
3:2 MeCN/ HCO ₂ H	0	2.0 (0.9)	2.7 (0.37)	77	66 (0.21)
3:2 MeCN/ HCO ₂ H	5	1.0 (0.9)	2.7 (0.37)	44	78 (0.14)
3:2 MeCN/ HCO ₂ H	0	1.0 (0.9)	2.7 (0.37)	66	71 (0.20)
3:2 MeCN/ HCO ₂ H	0	2.0 (0.9)	2.7 (0.37)	80 ^ξ	51 (0.17) ^ξ
3:2 MeCN/ HCO ₂ H	0	2.0 (0.9)	2.7 (0.37)	80 ^ξ	56 (0.19) ^ξ
3:2 MeCN/ HCO ₂ H	0	2.0 (0.9)	2.7 (0.37)	86 ^ξ	54 (0.19) ^ξ

^a Determined by gc; ^ξ Reactions performed by using 50mm longer outlet tubes

Increasing the residence time within the V-19 microreactor apparatus by increasing the length of the outlet tubes was also found to be beneficial to the conversion, but selectivity fell somewhat, presumably because of similar reasons as described in section 6.3.1.

In view of the experiments detailed in table 6.4, it can be argued that the V-19 microreactor operates in a much more improved manner over conventional direct

fluorination methodology. It is reasoned that efficient mixing (by maximising the gas-liquid interfacial area) and heat transfer are the main reasons for the improvements.

6.3.2.2 1-Methyl-2,4-dinitrobenzene (89)

Following the direct fluorination of (87) as described in section 6.3.2.1, we next turned our attention to the direct fluorination of (89) (See Fig 6.4), a compound that is highly deactivated towards electrophilic substitution. Reaction conditions were similar to those described for the fluorination of (87) (See Fig 6.3 and Table 6.3), and these are shown in figure 6.4 and table 6.4. The reaction was performed at 5 and 0°C respectively, although it should be noted that longer outlet tubes were used in the latter experiments. The major product (90), was identified by comparison to literature data.²⁹⁶

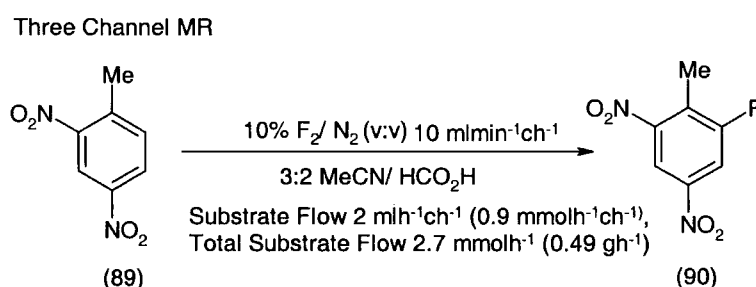

Fig 6.4

Table 6.4: Direct fluorination of 1-methyl-2,4-dinitrobenzene (89) in 3:2 acetonitrile/methanoic acid using a three channel microreactor

Temperature °C	Conversion ^a %	% Yield ^a of (90) (gh ⁻¹ of fluoro product)
5	40	70 (0.15)
5	40	66 (0.14)
0	48 ^ξ	68 (0.18) ^ξ
0	51 ^ξ	61 (0.18) ^ξ

^a Determined by gc; ^ξ Reaction performed by using 50mm longer outlet tubes

Several experiments were performed using the V-19 microreactor; for example, the fluorination of (89) in a 3:2 acetonitrile/ methanoic acid solvent system gave a 40% conversion and a 70% yield of (90). By comparison, Grakauskas²⁹⁶ has reported that the fluorination of (89), using conventional fluorination methodology in acetonitrile at low temperature (-35°C), gave a 5% yield of (90). A direct comparison indicates that the microreactor performs in a far superior manner, however it is anticipated that some degree of the improvement is also attributable to the use of methanoic acid as co-solvent.

In contrast to previous experiments where utilising longer outlet tubes increased conversion while at the same time decreasing the selectivity, in this present example the attachment of longer outlet tubes to the V-19 microreactor apparatus was found to slightly increase the conversion of (89), without significantly decreasing the selectivity towards (90). It is thought that the relative inertness of (89) towards electrophilic substitution by fluorine is a possible explanation for this observation.

6.3.3 3-Nitrophenyl Disulfide (91)

The direct fluorination of (91) with elemental fluorine has been described recently by Philp.¹⁴⁴ However, the very nature of the -SF₅ group requires that a high molar ratio of fluorine be used, and in fact when conventional batch fluorination methodology is used, approximately fifteen equivalents of fluorine is required to convert (91) into the -SF₅ derivative (93), albeit in moderate yield (39%). Moreover, the fluorination reaction is found to give better results if the reaction mixture is warmed to room temperature part way through the process.

To further highlight reactions that can be performed using microreactor technology, the direct fluorination of (91) (See Figs 6.5 and 6.6) was performed using the V-19 microreactor apparatus in a two-step and one-step manner, and these results are shown in tables 6.5 and 6.6. The one step procedure involves the fluorination of (91) to (93) directly within the microreactor, while the two-stage process involves first the bulk fluorination of (91) to (92), subsequently followed by the fluorination of (92) to (93) in the V-19 microreactor. Both methods have been described by Chambers and Harston.¹⁶⁴

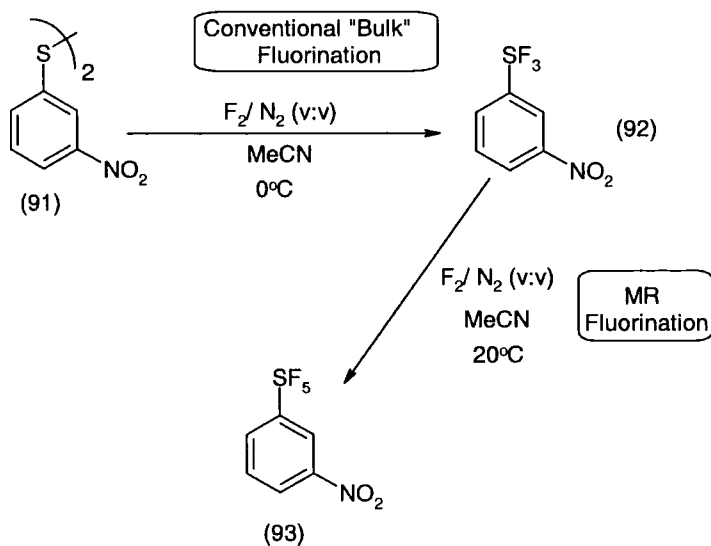

Fig 6.5: Two-step procedure; flow rate through the microreactor equals $7.3 \text{ mlh}^{-1} \text{ch}^{-1}$

Table 6.5: Two-step direct fluorination of 3-nitrophenyl disulfide (91) using (i) bulk fluorination methodology, followed (ii) V-19 microreactor

% Yield* of (92)	% Yield* of (93)
75	41
62	56
56	52

* Determined by ^{19}F NMR and all reactions were performed by using 50mm longer outlet tubes

Using the two-stage approach (See Fig 6.5 and Table 6.5), the majority of (91) is prefluorinated to give the intermediate (92). Consequently, a high flow rate of the solution of (92) can be obtained (compared to the analogous flow rate of a solution of (91) through the microreactor) because of the lower amount of fluorine required to complete the reaction.

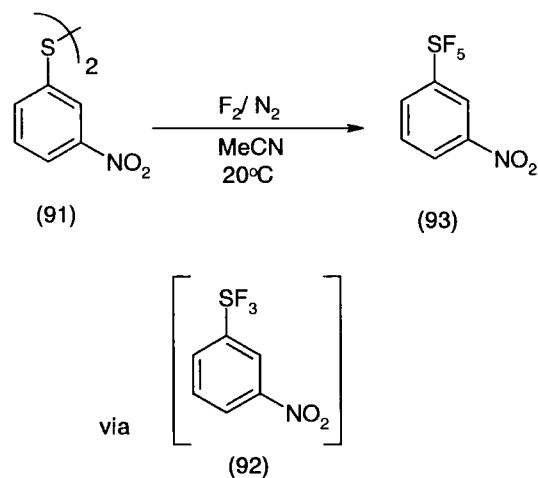

Fig 6.6: One-step fluorination

Table 6.6: One-step direct fluorination of 3-nitrophenyl disulfide (91) using a triple channel microreactor

Substrate Flow $\text{mlh}^{-1}\text{ch}^{-1}$ $(\text{mmolh}^{-1}\text{ch}^{-1})$	Total Substrate Flow mmolh^{-1} $(\text{gh}^{-1} \text{ of substrate})$	Fluorine Concentration (%) $(\text{mmolh}^{-1}\text{ch}^{-1})$	% Yield ^a of (93) $(\text{gh}^{-1} \text{ of fluoro}$ product)
2.0 (0.12)	0.36 (0.11)	10 (2.6)	60 (0.11)
1.0 (0.06)	0.18 (0.06)	10 (2.6)	40 (0.04)
2.5 (0.15)	0.45 (0.14)	20 (5.2)	55 (0.12)
3.5 (0.21)	0.63 (0.19)	20 (5.2)	52 (0.16)
2.0 (0.12)	0.36 (0.11)	20 (5.2)	42 (0.08)

^a Determined by ^{19}F NMR and all reactions were performed by using 50mm longer outlet tubes

The one-step fluorination of (91) was investigated under a range of conditions (See Fig 6.6 and Table 6.6); for example, using a substrate flow of $2 \text{ mlh}^{-1}\text{ch}^{-1}$ ($0.12 \text{ mmolh}^{-1}\text{ch}^{-1}$) and a twenty-two fold excess of fluorine resulted in a 60% yield of (93). To increase the throughput of substrate through the microreactor 20% fluorine was utilised, and as a result, using a substrate flow rate of $3.5 \text{ mlh}^{-1}\text{ch}^{-1}$ ($0.21 \text{ mmolh}^{-1}\text{ch}^{-1}$) and a

twenty-five fold excess of fluorine, a 52% yield of (93) was obtained. It is worth pointing out that accompanying (93) in all experiments (in both procedures) was also detected the presence of (92) to the extent of between 14-35%, as a result of incomplete fluorination of the disulfide.

It is reasonable to conclude that other than the increased flow rate of material through the reactor, there was no other significant benefit observable by performing the reaction in a two-stage manner. On the other hand, the effect of the huge advantages of increased heat and mass transfer (i.e. mixing) upon both reaction processes cannot be ignored, since we are effectively reacting within the microreactor, one equivalent of (91) (or (92)) with between 6-43 fold excesses of fluorine instantaneously.

By comparison, the bulk fluorination of (91),¹⁴⁴ on an 81 mmol scale, takes 6hrs to complete the addition of the required amount of fluorine, (rate of 10% fluorine/nitrogen addition in the bulk phase is $\sim 750 \text{ mlmin}^{-1}$ or 0.195 mmolh^{-1}) at a rate of approximately 2.5 equivalents an hour.

6.3.4 V-19 Microreactor Conclusion

We have demonstrated that the concept of scale-out can be achieved for gas-liquid fluorination microreactors. Furthermore, by the aid of several different types of fluorination reaction, we have demonstrated that fluorination microreactors give conversions and yields which are at least comparable to or better than conventional bulk liquid phase fluorination. Using the V-19 microreactor, the unoptimised hourly production rate of monofluorinated compound lies between $0.07\text{-}0.69\text{gh}^{-1}$. This small amount of product, while being higher than the hourly production rate using the single channel microreactor, from a commercial point of view, the mass of material per hour is still unsatisfactory.

Reactor dimensions have also been found to be important with regard to reaction outcome, since conversions can be improved by extending the length of the outlet tubes (by increasing the contact/ residence time within the reactor apparatus).

Improvements to the design of the V-19 microreactor led initially to the development of the V-20 microreactor and then subsequently to the V-21 microreactor (See chapter 5), which will be discussed in the following section.

6.4 V-21 Microreactor (Multi-Channel Microreactor)

As mentioned above, before the development of the V-21 microreactor, the V-20 microreactor was designed and fabricated. However, due to a design flaw in the V-20 microreactor, we will not discuss the few results obtained from this microreactor, and consequently, we describe next the results obtained from its successor, the V-21 microreactor.

As discussed in chapter 5, section 5.4, the V-21 microreactor has been designed with detachable channel templates in mind, and as a result several different channel templates were fabricated.

6.4.1 Three Channel Template Plate (V-21-3)

Direct fluorination of (71) (See Fig 6.7) using the V-21 microreactor and the three-channel template (V-21-3) was repeated several times under identical conditions, as shown in table 6.7. Using a substrate flow of $0.5 \text{ mlh}^{-1}\text{ch}^{-1}$ and a $10 \text{ mlmin}^{-1}\text{ch}^{-1}$ fluorine flow, an average a conversion of 74% and a yield of 91% of (72) was obtained. Moreover, it should be pointed out that these reactions were effectively the result of continuous operation for seven days, apart from the fact that due to physical limits on the amount of fluorine and substrate that can be stored, a thirty minute down time was required to replenish fluorine and liquid stocks and purge the system with nitrogen.

Increasing the flow of fluorine was found to increase the conversion of (71) without substantially affecting the selectivity towards (72). Reducing the liquid flow rate (thereby increasing the residence time within reactor) was also found to be highly beneficial, although the selectivity for (72) was reduced to 80%.

V-21-3 MR

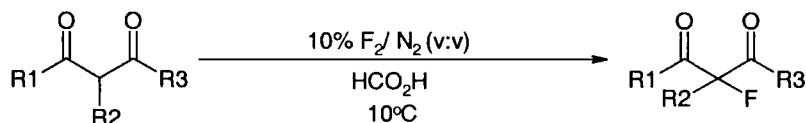
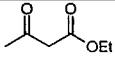



Fig 6.7

A further example was studied, namely the direct fluorination of (77). It was found that a 74% conversion and a 98% yield of (78) could be achieved by using a liquid flow rate of $0.5 \text{ mlh}^{-1}\text{ch}^{-1}$ and a fluorine flow rate of $10 \text{ mlmin}^{-1}\text{ch}^{-1}$. Moreover, increasing the residence time within the reactor apparatus, improved the conversion without perturbing the selectivity of the reaction towards (78).

By comparison to previous microreactor results, described in sections 6.2 and 6.3.1, the V-21-3 microreactor system can be seen to be analogous to or better than these aforementioned microreactors. Moreover, we have demonstrated that consistent results may be obtained over a substantial operation period.

Table 6.7: Direct fluorination of 1,3-dicarbonyls using a multi-channel microreactor with a three -channel template

1,3-Dicarbonyl	Substrate Flow mlh ⁻¹ ch ⁻¹ (mmolh ⁻¹ ch ⁻¹)	10% F ₂ Flow mlmin ⁻¹ ch ⁻¹	Total Substrate Flow mmolh ⁻¹ (gh ⁻¹ of substrate)	Conversion ^a %	% Yield ^a of monofluoro product (gh ⁻¹ of fluoro product)
 (71)	0.5	10	5.4 (0.70)	75	92 (0.55)
	0.5	10	5.4 (0.70)	62	90 (0.45)
	0.5	10	5.4 (0.70)	76	92 (0.56)
	0.5	10	5.4 (0.70)	77	91 (0.56)
	0.5	10	5.4 (0.70)	74	90 (0.53)
	0.5	10	5.4 (0.70)	86	94 (0.65)
	0.5	10	5.4 (0.70)	71	91 (0.52)
	0.5	15	5.4 (0.70)	91	87 (0.63)
	0.5	15	5.4 (0.70)	93	86 (0.64)
	0.25	10	2.7 (0.35)	100	80 (0.32)
 (77)	0.5	10	6.0 (0.71)	74	98 (0.64)
	0.25	10	3.0 (0.36)	95	96 (0.40)

^a Determined by gc

6.4.2 Nine Channel Template Plate (V-21-9)

To further demonstrate the scale-out potential of the V-21 microreactor, we next turned our attention to the use of a nine-channel template (V-21-9). The fluorination of (71) (See Fig 6.8) was performed under analogous conditions to those used with the V-21-3 microreactor system. Overall results using a 10 mlmin⁻¹ch⁻¹ flow of fluorine and a 0.5

mlh⁻¹ch⁻¹ flow of substrate solution (See Table 6.8) gave an average conversion of 74% and a yield of (72) of 92%, which are similar to those obtained from the V-21-3 system.

Increasing the concentration of fluorine was also found to increase the conversion of (71), while not affecting the yield of (72) to any great extent.

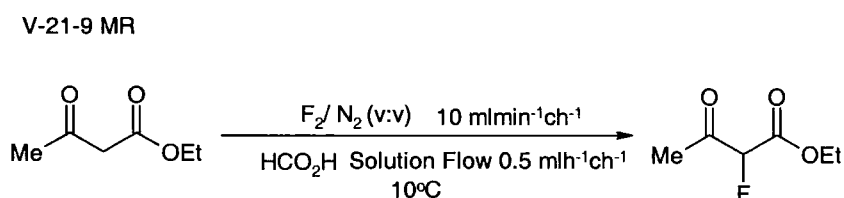

Fig 6.8

Table 6.8: Direct fluorination of ethyl 3-oxobutanoate (71) using a multi-channel microreactor with a nine-channel template

1,3-Dicarbonyl	Fluorine Concentration %	Conversion ^a %	% Yield ^a of (72) (gh ⁻¹ of fluoro product)
 (71)	10	74	91 (1.61)
	10	74	91 (1.61)
	10	63	92 (1.39)
	10	76	91 (1.66)
	10	75	91 (1.64)
	10	80	95 (1.82)
	10	78	91 (1.70)
	20	83	87 (1.73)
20	93	94 (2.10)	

^a Determined by gc

6.4.3 V-21 Microreactor Conclusion

We have demonstrated that the V-21 microreactor system offers a practical solution for a commercial fluorination device, although further modifications could still be made to the V-21 microreactor design. It has also been demonstrated that scale-out by changing the three-channel template for a nine-channel template is possible without affecting the reaction outcome.

Using the V-21-3 microreactor system, the un-optimised hourly production rate of monofluorinated 1,3-dicarbonyl compound lies between $0.32\text{-}0.65\text{gh}^{-1}$; for the V-21-9 microreactor system, the un-optimised hourly production rate of monofluorinated 1,3-dicarbonyl compound lies between $1.61\text{-}2.10\text{gh}^{-1}$. Since it has been demonstrated that scale-out by changing the three-channel template for a nine-channel template is possible without affecting the reaction outcome, one can anticipate that changing the nine-channel plate for a thirty-channel plate would result in an analogous situation. Furthermore, the use of both sides of the reactor would effectively double the amount of material produced by one device. A simple extrapolation of the results to say a sixty-channel reactor device (thirty channels each side of the block) would result in an hourly production rate of between $10.7\text{-}14.0\text{gh}^{-1}$ for (71). Further extrapolation to a weeks production gives values of between $\sim 1.8\text{-}2.4\text{Kg}$ per week, which could theoretically be extrapolated to a years continual production of between $93\text{-}122\text{Kg}$ per year from one device. It follows then that ten sixty-channel microreactor devices can produce approximately one ton of material per year, which is comparable to small scale pilot plant operation, or enough to satisfy a fine chemical manufacturer. (It should be pointed out that a small error is introduced upon start-up of the microreactor due to starting material being sent through the microreactor unconverted. Hence the small discrepancy between the values concerning the V-21-3 and V-21-9 results is observed. Operation of the experiment for long periods of time, or disposal of the first half hour of material could remove this error.)

It should be pointed out that this has not yet been demonstrated due to restraints concerning the scale of reactions which can be performed in our current laboratories, although one anticipates that this is merely a case of when this will be demonstrated rather than if it is demonstrated.

6.5 Chapter 6 Summary

Overall, we have found that direct fluorination performed using microreactor technology gave results which are comparable to or better than conventional bulk fluorination methodology. Improved heat and mass transfer are the major benefits of using microreactor technology, although one cannot forget that associated closely with these benefits, is the improved safety that can be achieved by using this technology.

Chapter 7.0: Experimental to Chapter 2.0

7.1 Instrumentation

Reagents, Materials, and Solvents

Unless otherwise stated, chemicals were supplied by Aldrich, Air Products, Avocado, Lancaster, or Fluorochem. All solvents were dried according to literature methods. Column chromatography was performed using silica gel supplied by Fluorochem.

Gas Liquid Chromatography

Chromatographic analyses were performed on a Hewlett Packard 5890 Series II gas liquid chromatograph equipped with a 25 m cross-linked methyl silicone capillary column with a flame ionisation detector.

Elemental Analysis

Carbon, hydrogen and nitrogen analysis were obtained using an Exeter Analytical CE-440 Elemental Analyser.

NMR Spectroscopy

^1H , ^{13}C , and ^{19}F spectra were obtained from the following spectrometers: Varian Mercury 200, Bruker AM-250, Varian Unity 300, Varian VXR400, Varian Mercury 400 Spectrometer, and Varian Inora 500. ^1H spectra were recorded at 200, 300, 400, 500MHz, ^{13}C spectra were recorded at 75, 100, 126 MHz and ^{19}F spectra were recorded at 188, 376, 470 MHz. All spectra were obtained using either $(\text{CH}_3)_4\text{Si}$, $(\text{CH}_3)_2\text{SO}$, CHCl_3 and/or CFCl_3 as internal references. J values are given in Hertz.

Mass Spectroscopy

Mass spectra were obtained from a VG Trio 1000 mass spectrometer (electronic and chemical ionisation) coupled to a GLC as above. Mass spectra were also obtained from a Finigan Trace MS mass spectrometer (electronic ionisation). Accurate mass determinations were performed on a Micromass Autospec mass spectrometer and at the EPSRC national mass spectrometry centre, Swansea.

IR Spectra

Infrared spectra were recorded on a Perkin-Elmer 1600 FT-IR using KBr discs or thin film liquid between KBr plates.

X-Ray Analysis

Crystal structures were obtained from a Bruker Smart 1K CCD diffractometer or a Bruker Smart 6K CCD diffractometer. Structure solution (direct methods) and least-squares refinement (non-H atoms anisotropic, all H refined isotropically, against F^2 of all data) with SHELX-97 software (G. M. Sheldrick, University of Göttingen, Germany, 1997)

Melting Point Analysis

Melting points were obtained from a Gallenkamp melting point apparatus and are not corrected.

7.2 The Use of Elemental Fluorine in the Laboratory

Elemental fluorine is an extremely reactive and very toxic chemical; hence, it is necessary to use apparatus, which has been specially designed to enable the use of elemental fluorine in a safe and controllable manner (See Fig A).

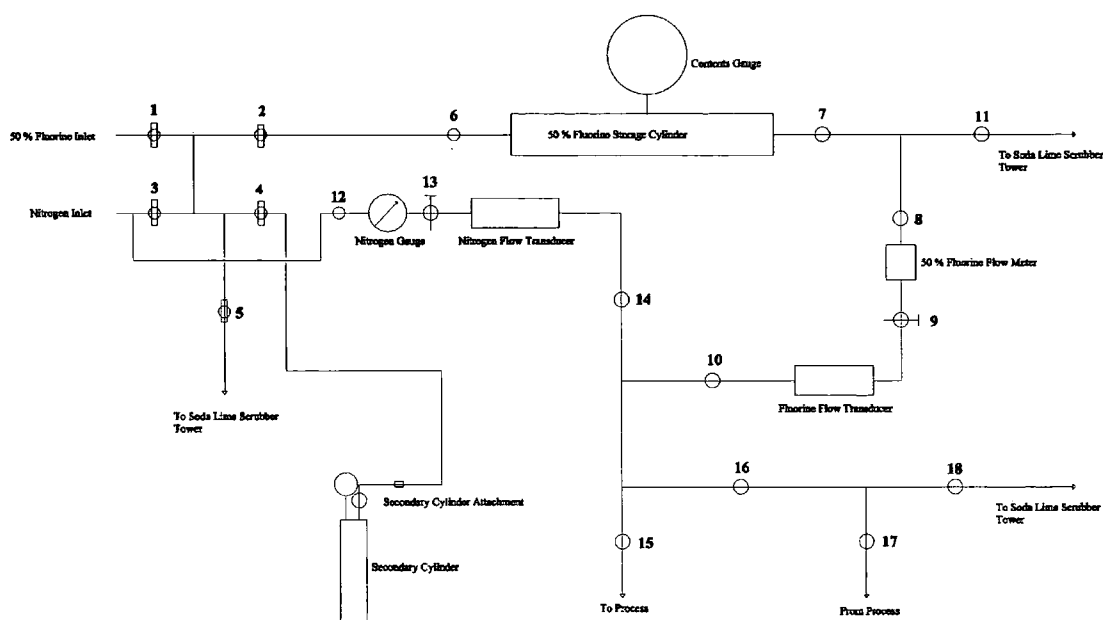

Fig A

Cylinders of 50 % fluorine/ nitrogen are obtained from air products, and shipped in high-pressure cylinders (size K). The cylinder contains 1.4 m^3 of the gas mixture, at a pressure of 2.76 MPa (approximately 27 bar). The fluorine is regulated from the primary cylinder pressure to 4 bar, by the use of a regulator.

The fluorine cylinder is situated inside a vented gas cabinet (not Shown), and is attached to a manifold equipped via a metal-metal connection with a pneumatic shut-off valve (See Fig B), which is operated remotely. It is important that organic materials, such as PTFE, are not used in this connection as reaction of elemental fluorine with the aforementioned material is possible because of the relatively high pressure and concentration of fluorine at this point. The safe use of elemental fluorine is covered by the university safety policy (**Appendix R**) and will not be discussed further. Fluorine is supplied to two rigs, the microreactor rig and the right-hand rig. Using the right-hand rig

it is possible to fill portable 3.7 litre cylinders up to a maximum pressure of 5 bar. These portable cylinders can be detached from the right-hand rig and installed in to other fumehoods possessing fluorine handling apparatus. Under no circumstances should reactions be performed directly from the main fluorine cylinder.

Nitrogen is supplied from a high-pressure cylinder (size K) at a pressure of approximatley 230 bar, which is regulated to 10 bar by a regulator (See Fig C).

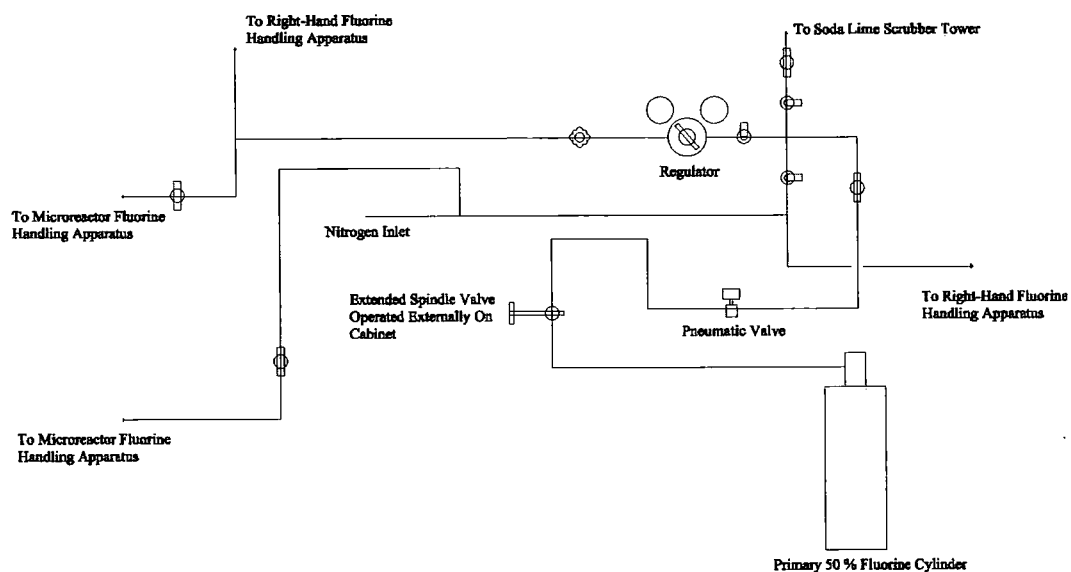

Fig B

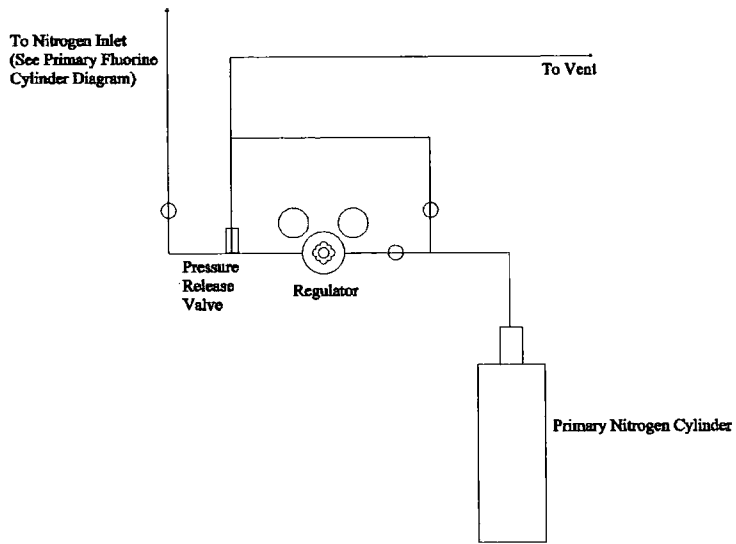

Fig C

The Right-Hand Rig Fluorine Gas Handling Apparatus

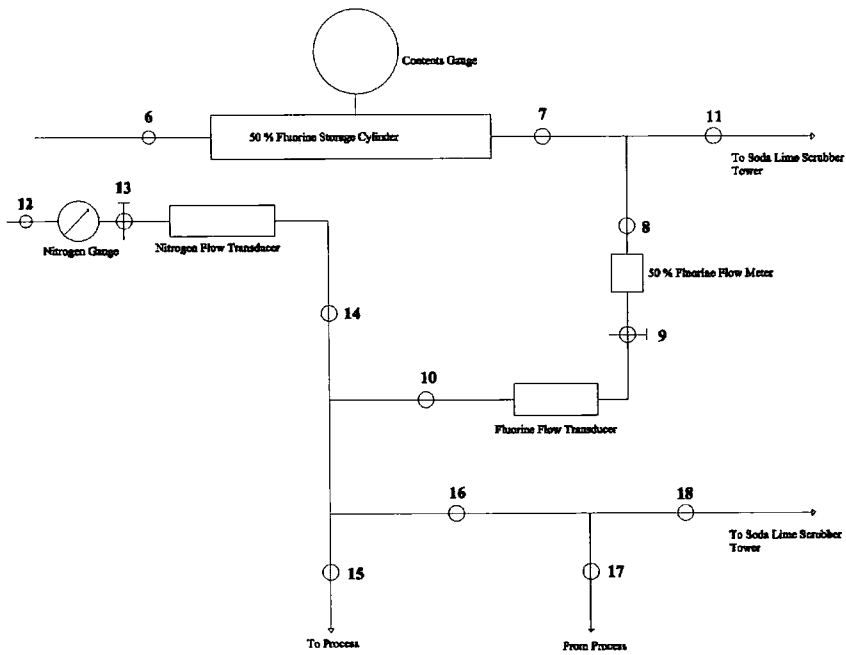

Fig D

Apparatus Construction

The apparatus is constructed from stainless steel pipe work and is fitted with Monel swagelok[®] valves (valves 9 and 13: metering valves, Valves 1 to 5: Severe service union bonnet valves, and all other valves being Integral bonnet needle valves). The storage cylinder is constructed from stainless steel (5L).

Filling Secondary Cylinders (See Fig D and E)

When filling secondary cylinders with fluorine, at least two members of the group must be present and each person must be equipped with a face-shield and nitrile or PVC gauntlets (In addition to the standard personal protective equipment worn in a laboratory.). The following procedure is used to fill the portable secondary cylinders:

- 1) Ensure all valves are closed
- 2) The primary fluorine cylinder is turned on following usual procedure
- 3) The secondary cylinder is attached to the apparatus
- 4) Valves 4 and 5 are opened followed by the secondary cylinder valve (SCV)
- 5) The SCR is closed as-well as valve 5
- 6) Valve 1 is opened, the SCV is opened slowly until the required amount of fluorine is collected
- 7) The SCV is closed, followed by valve 1
- 8) Valve 5 is opened and closed after a few seconds
- 9) Valve 3 is opened and the SCV slowly opened until the required amount of nitrogen is collected (maximum of 5 bar in total)
- 10) The SCR is closed, followed by valve 3
- 11) Valve 5 is opened and closed after a few seconds
- 12) The secondary cylinder is detached from the apparatus
- 13) Steps 3-12 are repeated for successive secondary cylinders, afterwards the primary fluorine cylinder is shut off following usual procedure

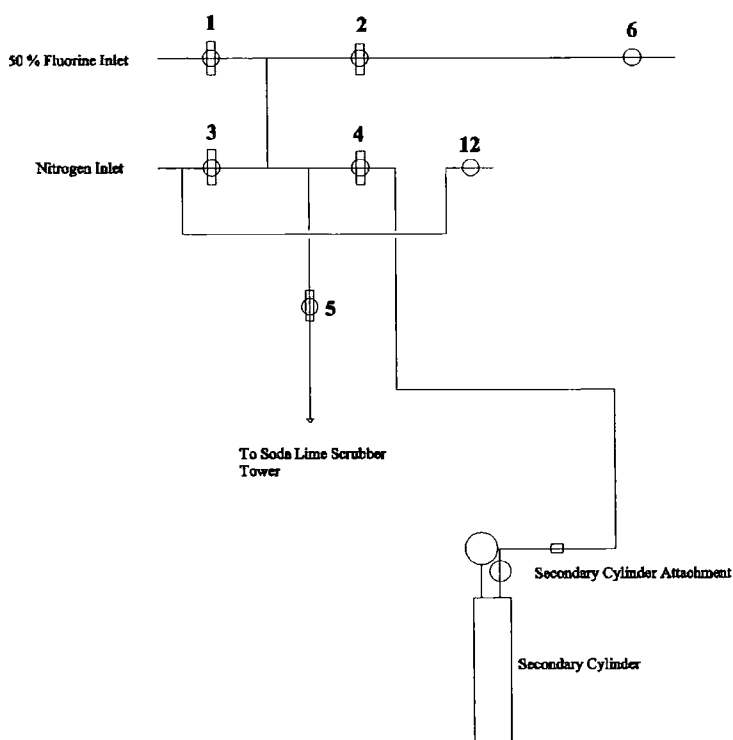

Fig E

50 % Fluorine Storage Cylinder Filling Procedure (See Fig D)

- 1) Ensure all valves are closed
- 2) The primary fluorine cylinder is turned on following the usual procedure
- 3) Open valves 1 and 2
- 4) Slowly open valve 6 until the storage cylinder is full (maximum 4 bar)
- 5) Close valve 6 followed by valves 1 and 2
- 6) Open valve 5, then close valve 5
- 7) Isolate primary fluorine cylinder following usual procedure

Operation of Right-Hand Rig Fluorination Procedure

- 1) Ensure all valves are closed
- 2) The reaction vessel to be used is attached to the "To Process and From Process" connectors
- 3) Open valves 15, 17, and 18

- 4) Open valve 12, and then slowly open valve 13 until the desired flow of nitrogen is obtained as indicated by the nitrogen flow meter
- 5) After purging the reaction vessel, open valves 7, 8, and 10
- 6) Slowly open valve 9 until the desired flow of 50 % fluorine is obtained, as indicated by the flow transducer
- 7) Termination of the experiment, involves closing valves 7 and 8
- 8) Valves 9 and 10 are closed when the flow of 50 % fluorine has fallen to zero
- 9) Reaction is thoroughly purged, then valves 12, 13, 14, 15, 17, and 18 are closed

The Microreactor Fluorine Gas Handling Apparatus

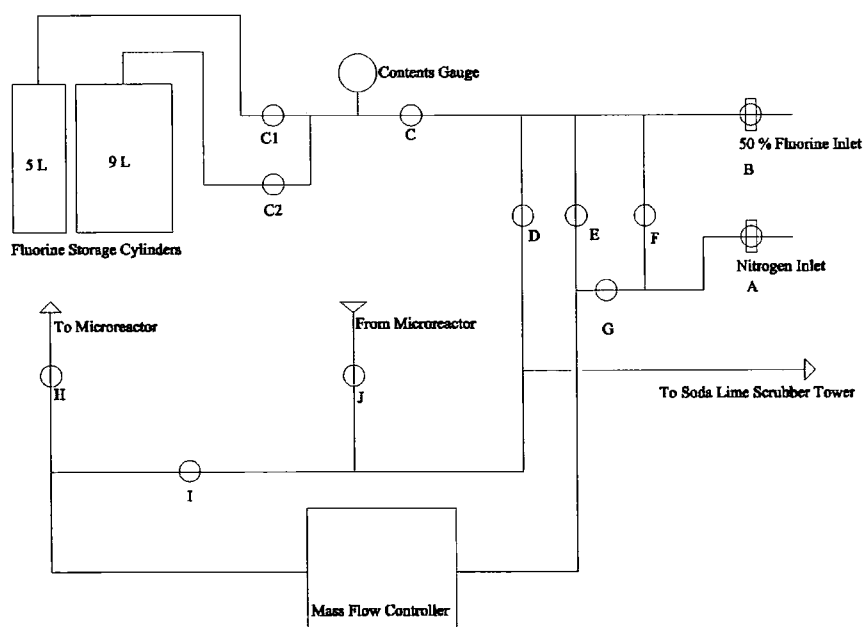

Fig F

Apparatus Construction

The apparatus is constructed from stainless steel pipe work and is fitted with Monel swagelok[®] valves (valves C to J: Integral bonnet needle valves, Valves A and B: Severe service union bonnet valves). The storage cylinders are constructed from stainless steel (5L) and mild steel (9L). The mass flow controller is a Brooks 5850S and is controlled by

a DDE computer program obtained from Flotech Solutions® linked to a PC operating in Microsoft® Excel.

Microreactor Storage Cylinder Filling Procedure (See Fig F)

- 1) Ensure all valves are closed
- 2) The primary fluorine cylinder is turned on following usual procedure
- 3) Ensure storage tanks are empty (Open C1, C2, C, and D; then when empty close C1, C2, C, and D)
- 4) Open valve B
- 5) Open valve C1. Open valve C and slowly fill tank with required amount of Fluorine
- 6) Close valve C and then valve C1
- 7) Open valve C2 and then valve C, Slowly fill tank with the required amount of Fluorine
- 8) Close valve C, close valve C2
- 9) Close valve B. Isolate primary fluorine cylinder following usual procedure
- 10) Open valve D and then Close Valve D
- 11) Open valve A, open valve F
- 12) Repeat steps 5 to 8 with Nitrogen
- 13) Close valve F and valve A

Operation of Microreactor Rig Fluorination Procedure

- 1) Ensure all valves are closed
- 2) Open valves A, G, H, and I
- 3) Set flow at desired level using mass flow, purge with nitrogen for 15 minutes
- 4) Close valves A and G
- 5) Open valves C1, C2, C and then valve E, allow fluorine to flow for 5 minutes, before starting flow of liquid substrate through microreactor
- 6) Termination of the experiment, involves closing valves C1, C2, C and then E
- 7) Open valves A and G and purge for 15 minutes; close all valves

Bulk Fluorination Apparatus

All bulk fluorinations, which are described in this thesis, were performed in a glass reactor having the design shown in fig G. Fluorine was supplied to the bottom of the reaction vessel using a PTFE dip-pipe having an outlet diameter of 1/16"; waste gases exited the reaction vessel to scrubber tower, which was filled with soda lime granules.

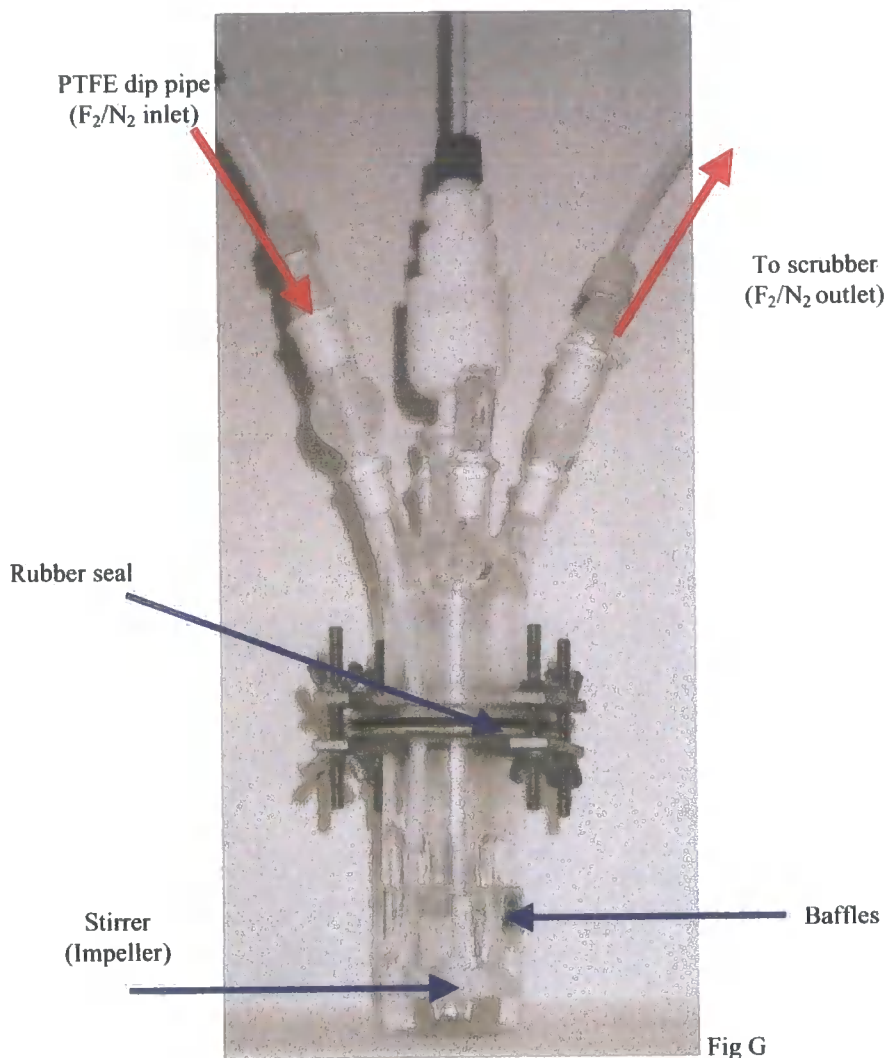

7.3 General Procedure

The reactions below follow the procedure described, unless otherwise stated. Reaction apparatus was purged with nitrogen thoroughly, before and after fluorination. The reaction was cooled in a salt water bath to 0-1°C by an external cryostat. Reactant was charged into a glass reaction vessel containing sulfuric acid (> 98%) (100 ml). The solution was rapidly stirred using an overhead stirrer, typically at 350 revolutions min⁻¹. Fluorine, diluted to 10% with dry nitrogen (v:v) was bubbled through the solution at a rate of 50 mlmin⁻¹ (13 mmolh⁻¹). Conversions and yields were determined from the ¹⁹F NMR of the crude product, by comparison of the peak integrals with the integral of an internal reference (trifluoromethylbenzene). A typical work-up involves pouring the reaction onto ice-slush (1500 ml), followed by neutralisation with sodium hydrogencarbonate. The mixture was subsequently filtered, and the filtrate extracted with dichloromethane; the combined extracts were dried over magnesium sulfate. Solvent was removed by rotary evaporation to leave crude reaction product.

Reactions involving PP11 use the following work-up procedure. The reaction is poured onto ice-water (400 ml) and the PP11 portion separated. The PP11 layer was further washed with water (50 ml), then dichloromethane, which were then added to the previously separated aqueous layer. The aqueous phase was neutralised with sodium hydrogencarbonate and subsequently filtered, filtrate was extracted with dichloromethane; the combined extracts were dried over magnesium sulfate. Solvent was removed by rotary evaporation to leave crude reaction product.

Crystals suitable for X-ray analysis were grown by the slow evaporation of a dichloromethane solution of the compound.

7.3.1 Direct Fluorination of quinoline (1)

Experiment 1 (Acetonitrile): Quinoline (2.0 g, 15 mmol) and fluorine (47 mmol, 3 equivalents). Gave a dark oil 13.0 g. Conversion was not determined due to significant tar being present in the crude reaction mixture. Analysis of the ¹⁹F NMR showed that a complex mixture of uncharacterised products was produced.

Experiment 2 (Methanoic acid): Quinoline (6.0 g, 45 mmol), methanoic acid (150 ml), and fluorine (90 mmol, 2 equiv., 20 mlmin⁻¹) cooled to 10°C. Gave a dark oil 7.84 g.

Conversion was not determined due to significant tar being present in the crude reaction mixture (~25%). Analysis of the ^{19}F NMR showed that four major products produced; later identified as 5-fluoroquinoline, 8-fluoroquinoline, 5,8-difluoroquinoline, and 5,6-difluoro-5,6-dihydroquinoline in the following proportions 3.8: 2.7: 1: 3.2 respectively.

Experiment 3: Quinoline (4.0 g, 30 mmol) and fluorine (180 mmol, 6 equivalents). Gave a dark yellow oil 5.91 g. Conversion was found to be 42%, which consisted of: 44% yield of 5-fluoroquinoline, 11% yield of 6-fluoroquinoline, 23% yield of 8-fluoroquinoline, and 13% yield of 5,8-difluoroquinoline (As compared to literature data.^{185, 215}).

Experiment 4: Quinoline (4.0 g, 30 mmol) and fluorine (180 mmol, 6 equivalents) cooled to 18°C. Gave a dark yellow oil 4.27 g. Conversion was found to be 51%, which consisted of: 27% yield of 5-fluoroquinoline, 8% yield of 6-fluoroquinoline, 16% yield of 8-fluoroquinoline, and 24% yield of 5,8-difluoroquinoline.

Experiment 5: Quinoline (4.0 g, 30 mmol) and fluorine (360 mmol, 12 equivalents). Gave a dark yellow oil 4.97 g. Conversion was found to be 67%, which consisted of: 27% yield of 5-fluoroquinoline, 8% yield of 6-fluoroquinoline, 14% yield of 8-fluoroquinoline, and a 32% yield of 5,8-difluoroquinoline was obtained.

Experiment 6: Quinoline (4.0 g, 30 mmol) was dissolved in sulfuric acid (10 ml)/ PP11 (90 ml); fluorine (221 mmol, 7.4 equivalents). Gave a dark yellow oil 5.93 g. Conversion was found to be 35%, which consisted of: 43% yield of 5-fluoroquinoline, 14% yield of 6-fluoroquinoline, 26% yield of 8-fluoroquinoline, 8% yield of 5,8-difluoroquinoline, and 3% yield of 5,6-difluoro-5,6-dihydroquinoline.

Experiment 7: Quinoline (4.0 g, 30 mmol) was dissolved sulfuric acid (20 ml)/ PP11 (80 ml); fluorine (221 mmol, 7.4 equivalents). Gave a dark yellow oil 8.26 g. 22% Conversion was found to be 22%, which consisted of: 48% yield of 5-fluoroquinoline, 11% yield of 6-fluoroquinoline, 27% yield of 8-fluoroquinoline, and 8% yield of 5,8-difluoroquinoline.

Purification was achieved using chromatography on silica, diethyl ether as elutant; 5,8-difluoroquinoline was further purified by recrystallisation from hexane.

5-Fluoroquinoline (2): Yellow oil; 0.1 g; $\delta^1\text{H}$ (500 MHz; CDCl_3) 8.77 (dd, 1H, $^3\text{J}_{\text{HH}}$ 4.5 $^4\text{J}_{\text{HH}}$ 1.5, H₂), 8.23 (dm, 1H, $^3\text{J}_{\text{HH}}$ 8.5, H₄), 7.77 (d, 1H, $^3\text{J}_{\text{HH}}$ 8.5, H₈), 7.46 (td, 1H, $^3\text{J}_{\text{HH}}$ 8.0 $^4\text{J}_{\text{HF}}$ 6.0, H₇), 7.25 (dd, 1H, $^3\text{J}_{\text{HH}}$ 8.5 $^3\text{J}_{\text{HH}}$ 4.0, H₃), 7.03 (m, 1H, H₆); $\delta^{19}\text{F}$ (470 MHz;

CDCl₃) -123.3 (dd, ³J_{HF} 9.4 ⁴J_{HF} 5.6, F₅); δ¹³C (126 MHz; CDCl₃) 157.5 (d, ¹J_{CF} 255.0, C₅), 150.9 (s, C₂), 148.6 (d, ⁴J_{CF} 3.0, C_{8α}), 129.0 (d, ³J_{CF} 4.5, C₄), 128.7 (d, ³J_{CF} 8.9, C₇), 125.0 (s, C₈), 120.9 (d, ⁴J_{CF} 6.9, C₃), 118.8 (d, ²J_{CF} 16.5, C_{4α}), 109.8 (d, ²J_{CF} 18.9, C₆); m/z (EI⁺) 147 (M⁺, 100 %); found: M⁺ 147.048546. C₉H₆FN requires M⁺ 147.048427.

6-Fluoroquinoline (not isolated) (3): δ¹⁹F (188 MHz; CDCl₃) -114.3 (d, ³J_{HF} 4.7, F₆).

8-Fluoroquinoline (4): Yellow oil; 0.1 g; δ¹H (500 MHz; CDCl₃) 8.81 (dm, 1H, ³J_{HH} 4.0, H₂), 8.00 (dm, 1H, ³J_{HH} 8.5, H₄), 7.43 (dm, 1H, ³J_{HH} 8.0, H₆), 7.33-7.21 (m, 3H, H₃ H₅ H₇); δ¹⁹F (470 MHz; CDCl₃) -126.2 (dd, ³J_{HF} 10.3 ⁴J_{HF} 4.7, F₈); δ¹³C (126 MHz; CDCl₃) 157.6 (d, ¹J_{CF} 257.0, C₈), 150.1 (s, C₂), 138.0 (d, ²J_{CF} 12.0, C_{8α}), 135.6 (s, C₄), 129.4 (d, ³J_{CF} 2.5, C_{4α}), 126.0 (m, C₃), 123.1 (d, ⁴J_{CF} 4.5, C₅), 121.7 (d, ³J_{CF} 7.6, C₆), 113.1 (d, ²J_{CF} 18.5, C₇); m/z (EI⁺) 147 (M⁺, 100 %); found: M⁺ 147.048437. C₉H₆FN requires M⁺ 147.048427.

5,8-Difluoroquinoline (5): 0.25 g; White solid; mp 59-61°C; δ¹H (500 MHz; CDCl₃) 9.02 (dd, 1H, ³J_{HH} 4.0 ⁴J_{HH} 1.0, H₂), 8.43 (dm, 1H, ³J_{HH} 8.5, H₄), 7.55 (dd, 1H, ³J_{HH} 8.5 ³J_{HH} 4.0, H₃), 7.35 (td, 1H, ³J_{HF} 9.5 ³J_{HH} 4.5, H₇), 7.16 (td, 1H, ³J_{HF} 8.5 ³J_{HH} 4.0, H₆); δ¹⁹F (470 MHz; CDCl₃); -127.4 (ddd, 1F, ⁵J_{FF} 21.6 ³J_{HF} 9.4 ⁴J_{HF} 5.2, F₅), -130.2 (ddd, 1F, ⁵J_{FF} 22.1 ³J_{HF} 9.9 ⁴J_{HF} 3.3, F₈); δ¹³C (75 MHz; CDCl₃) 154.3 (dd, ¹J_{CF} 251.2 ⁴J_{CF} 3.8, C₈), 153.5 (dd, ¹J_{CF} 250.1 ⁴J_{CF} 3.8, C₅), 151.3 (d, ⁴J_{CF} 1.6, C₂), 138.3 (m, C_{8α}), 129.5 (dd, ³J_{CF} 3.7 ⁴J_{CF} 2.4, C₄), 122.1 (d, ⁴J_{CF} 2.1, C₃), 120.0 (dd, ²J_{CF} 18.3 ³J_{CF} 2.7, C_{4α}), 112.6 (dd, ²J_{CF} 21.6 ³J_{CF} 9.1, C₇), 109.5 (dd, ²J_{CF} 22.0 ³J_{CF} 7.7, C₆); ν_{max} (KBr disc)/cm⁻¹ 3054, 1683, 1654, 1639, 1597, 1506; m/z (EI⁺) 165 (M⁺, 100 %); M⁺, 165.038984. C₉H₅F₂N requires M, 165.039006.

5,6-Difluoro-5,6-dihydroquinoline (not isolated) (6): δ¹H (400 MHz; CDCl₃) 5.28 (1H, ddt, ¹J_{HF} 49.2 ³J_{FF} 17.2 ³J_{HF} 4.4, H₆), 5.58 (1H, ddd, ¹J_{HF} 48.8 ³J_{FF} 21.6 ³J_{HF} 4.0, H₅), 6.39 (1H, m, H₇), 6.86 (1H, dd, ³J_{HH} 10.0 ⁴J_{HF} 2.8, H₈), 7.23 (1H, dd, ³J_{HH} 7.6 ³J_{HH} 4.8, H₃), 7.78 (1H, d, ³J_{HH} 7.6, H₄), 8.56 (1H, d, ³J_{HH} 4.8, H₂); δ¹⁹F (376 MHz; CDCl₃) -201.1 (dm, 1F, ²J_{HF} 49.6, F₆), -201.7 (dd, 1F, ²J_{HF} 48.1 ³J_{FF} 11.7, F₅); δ¹³C (100 MHz; CDCl₃) 84.5 (dd, ¹J_{CF} 180.5 ²J_{CF} 17.8, C₆), 87.7 (dd, ¹J_{CF} 185.9 ²J_{CF} 18.2, C₅), 115.2 (d, ²J_{CF} 20.5, C_{4α}), 122.9 (s, C₃), 127.2 (dd, ²J_{CF} 18.2 ³J_{CF} 6.1, C₇), 129.9 (d, ³J_{CF} 7.9, C_{8α}), 133.3 (dd, ³J_{CF} 9.2 ⁴J_{CF} 1.6, C₈), 134.4 (d, ³J_{CF} 6.1, C₄), 150.2 (d, ⁵J_{CF} 2.2, C₂).

7.3.2 Direct Fluorination of 2-Chloroquinoline (7)

2-Chloroquinoline (2.5 g, 15 mmol) was added to an oleum (10 ml)/ PP11 (90 ml) medium; fluorine (180 mmol, 12 equivalents). Gave a yellow oil 3.4 g. Conversion was found to be 68%, which consisted of: 25% yield of 2-chloro-5-fluoroquinoline, 11% yield of 2-chloro-6-fluoroquinoline, 16% yield of 2-chloro-8-fluoroquinoline, and 21% yield of 2-chloro-5,8-difluoroquinoline.

2-Chloro-5-fluoroquinoline (not isolated) (8): $\delta^{19}\text{F}$ (188 MHz; CDCl_3) -122.4 (dd, $^3\text{J}_{\text{HF}}$ 10.2 $^4\text{J}_{\text{HF}}$ 6.4, F₅).

2-Chloro-6-fluoroquinoline (not isolated) (9): $\delta^{19}\text{F}$ (188 MHz; CDCl_3) -113.2 (m, F₆).

2-Chloro-8-fluoroquinoline (not isolated) (10): $\delta^{19}\text{F}$ (188 MHz; CDCl_3) -125.5 (dd, $^3\text{J}_{\text{HF}}$ 9.0 $^4\text{J}_{\text{HF}}$ 4.5, F₈).

2-Chloro-5,8-difluoroquinoline (not isolated) (11): $\delta^{19}\text{F}$ (188 MHz; CDCl_3) -126.5 (ddd, 1F, $^5\text{J}_{\text{FF}}$ 21.1 $^3\text{J}_{\text{HF}}$ 8.3 $^4\text{J}_{\text{HF}}$ 4.5, F₅), -129.6 (ddd, 1F, $^5\text{J}_{\text{FF}}$ 22.0 $^3\text{J}_{\text{HF}}$ 9.2 $^4\text{J}_{\text{HF}}$ 2.8, F₈).

7.3.3 Direct Fluorination of 4-Methylquinoline (12)

4-Methylquinoline (1.70 g, 12 mmol) and fluorine (39 mmol, 3.25 equivalents). Gave a dark oil 2.18 g. Conversion was found to be 26%, which consisted of: 48% yield of 5-fluoro-4-methylquinoline, 14% yield of 6-fluoro-4-methylquinoline, 23% yield of 8-fluoro-4-methylquinoline, and 6% yield of 5,8-difluoro-4-methylquinoline.

5-Fluoro-4-methylquinoline (not isolated) (13): $\delta^{19}\text{F}$ (188 MHz; CDCl_3) -112.1 (m, F₅).

6-Fluoro-4-methylquinoline (not isolated) (14): $\delta^{19}\text{F}$ (188 MHz; CDCl_3) -113.7 (m, F₆).

8-Fluoro-4-methylquinoline (not isolated) (15): $\delta^{19}\text{F}$ (188 MHz; CDCl_3) -125.7 (dd, $^3\text{J}_{\text{HF}}$ 10.0 $^4\text{J}_{\text{HF}}$ 5.5, F₈).

5,8-Difluoro-4-methylquinoline (not isolated) (16): $\delta^{19}\text{F}$ (188 MHz; CDCl_3) -116.2 (m, 1F, F₅), -129.0 (ddd, 1F, $^5\text{J}_{\text{FF}}$ 22.0 $^3\text{J}_{\text{HF}}$ 9.2 $^4\text{J}_{\text{HF}}$ 3.8, F₈).

7.3.4 Direct Fluorination of 6-Methoxyquinoline (17)

Experiment 1 (Methanoic acid): 6-Methoxyquinoline (2.4 g, 15 mmol) and fluorine (49 mmol, 3.25 equiv.) was cooled to 10 °C. Gave a dark oil 3.15 g. Conversion was found to be 100% and consisted of 27% 5-fluoro-6-methoxyquinoline and 18% 5,5-difluoro-5-hydro-6-oxoquinoline.

Experiment 2: 6-Methoxyquinoline (2.50 g, 16 mmol) and fluorine (52 mmol, 3.25 equivalents). Gave an orange oil 3.43 g. Conversion was found to be 71%, which consisted of: 74% yield of 5-fluoro-6-methoxyquinoline, and a 26% yield of 5,5-difluoro-5-hydroquinoline-6-one (As compared to literature data.¹⁸¹).

Purification was achieved using chromatography on silica, using diethyl ether as elutant.

5-Fluoro-6-methoxyquinoline (18): White solid; 1.1 g; m.p. 44-46°C; $\delta^1\text{H}$ (400 MHz; CDCl_3) 8.78 (dd, 1H, $^4\text{J}_{\text{HH}}$ 4.0 $^3\text{J}_{\text{HH}}$ 1.6, H₂), 8.31 (dm, 1H, $^3\text{J}_{\text{HF}}$ 8.4, H₄), 7.85 (dm, 1H, $^3\text{J}_{\text{HH}}$ 9.2, H₃), 7.48 (t, 1H, $^3\text{J}_{\text{HH}}$ $^4\text{J}_{\text{HF}}$ 9.2, H₇), 7.36 (dd, 1H, $^3\text{J}_{\text{HH}}$ 8.4 $^5\text{J}_{\text{HF}}$ 4.0, H₈); $\delta^{19}\text{F}$ (376 MHz; CDCl_3) -147.5 (s, F₅); $\delta^{13}\text{C}$ (100 MHz; CDCl_3) 149.0 (s, C₂), 145.1 (d, $^1\text{J}_{\text{CF}}$ 250.0, C₅), 143.2 (d, $^3\text{J}_{\text{CF}}$ 7.2, C_{8 α}), 143.1 (d, $^2\text{J}_{\text{CF}}$ 14.4, C₆), 128.0 (d, $^4\text{J}_{\text{CF}}$ 5.3, C₄), 125.4 (d, $^4\text{J}_{\text{CF}}$ 4.5, C₈), 121.2 (d, $^3\text{J}_{\text{CF}}$ 3.1, C₃), 119.6 (d, $^2\text{J}_{\text{CF}}$ 13.7, C_{4 α}), 118.5 (d, $^3\text{J}_{\text{CF}}$ 2.7, C₇), 57.4 (d, $^4\text{J}_{\text{CF}}$ 1.1, MeO); ν_{max} (KBr disc)/ cm^{-1} 3091, 3075, 3057, 3021, 2993, 2967, 2943, 2913, 2859, 2839, 1646, 1637, 1595, 1506; m/z (EI⁺) 177 (M⁺, 100 %), 134 (76.40); found C, 67.76; H, 4.56; N, 8.03. C₁₀H₈FNO requires C, 67.79; H, 4.55; N, 7.91 %.

5,5-Difluoro-5-hydroquinolin-6-one (19): Yellow solid; 0.44 g; m.p. 105-107°C; $\delta^1\text{H}$ (400 MHz; CDCl_3) 8.75 (dq, 1H, $^3\text{J}_{\text{HH}}$ 4.8 $^4\text{J}_{\text{HH}}$ 1.2, H₂), 8.10 (dm, 1H, $^4\text{J}_{\text{HF}}$ 8.1, H₄), 7.64 (d, 1H, $^3\text{J}_{\text{HH}}$ 10.4, H₈), 7.44 (dd, 1H, $^3\text{J}_{\text{HH}}$ 7.6 $^4\text{J}_{\text{HH}}$ 9.2, H₃), 6.46 (dt, 1H, $^3\text{J}_{\text{HH}}$ 10.4 $^4\text{J}_{\text{HF}}$ 4.0, H₇); $\delta^{19}\text{F}$ (376 MHz; CDCl_3) -102.4 (s, 2F, F₅); $\delta^{13}\text{C}$ (100 MHz; CDCl_3) 186.2 (t, $^2\text{J}_{\text{CF}}$ 24.2, C₆), 152.8 (t, $^5\text{J}_{\text{CF}}$ 1.9, C₂), 149.3 (t, $^3\text{J}_{\text{CF}}$ 6.1, C_{8 α}), 146.9 (s, C₈), 134.7 (t, $^3\text{J}_{\text{CF}}$ 2.7, C₄), 129.7 (t, $^2\text{J}_{\text{CF}}$ 24.3, C_{4 α}), 126.8 (t, $^3\text{J}_{\text{CF}}$ 2.7, C₇), 124.4 (s, C₃), 104.9 (t, $^1\text{J}_{\text{CF}}$ 245.0, C₅); ν_{max} (KBr disc)/ cm^{-1} 3149, 3090, 3069, 3060, 3027, 3010, 2978, 1699, 1575; m/z (EI⁺) 181 (M⁺, 100 %), 153 (82.10); found C, 59.68; H, 2.77; N, 7.82. C₉H₅FNO requires C, 59.68; H, 2.78; N, 7.73 %; X-ray crystallography (selected data) Temp.

100(2) K, $\lambda = 0.71073 \text{ \AA}$, Orthorhombic, Pnma, $a = 12.2462(9) \text{ \AA}$, $b = 6.6912(5) \text{ \AA}$, $c = 9.1757(7) \text{ \AA}$, $\alpha=90^\circ$, $\beta=90^\circ$, $\gamma=90^\circ$, $V = 751.87(10) \text{ \AA}^3$, Density (calc.) = 1.600 g/cm^3 , $R(\text{int}) = 0.0527$, Crystal size = $0.4 \times 0.4 \times 0.4 \text{ mm}^3$, $R1 = 0.033$, $wR2 = 0.103$.

7.3.5 Direct Fluorination of 2-Chloro-6-methoxyquinoline-3-carbaldehyde (20)

Experiment 1: 2-Chloro-6-methoxyquinoline-3-carbaldehyde (1.0 g, 4.5 mmol) was dissolved in sulfuric acid (10 ml)/ PP11 (90 ml) medium. Fluorine (22.5 mmol, 5 equiv). Gave 1.1 g of a yellow solid. (Conversion was found to be 23%, which consisted of: 97 % yield of 2-chloro-5-fluoro-6-methoxyquinoline-3-carbaldehyde and 3% yield of 2-chloro-5,5-difluoro-6-oxo-5-hydroquinoline-3-carbaldehyde)

Experiment 2: 2-Chloro-6-methoxyquinoline-3-carbaldehyde (2.0 g, 9 mmol) and fluorine (108 mmol, 12 equiv). Gave 2.02 g of a yellow solid. (Conversion was found to be 79%, which consisted of: 16% yield of 2-chloro-5-fluoro-6-methoxyquinoline-3-carbaldehyde and 84% yield of 2-chloro-5,5-difluoro-6-oxo-5-hydroquinoline-3-carbaldehyde)

Experiment 3: 2-Chloro-6-methoxyquinoline-3-carbaldehyde (1.5 g, 8 mmol) and fluorine (48 mmol, 6 equiv). Gave 1.6 g of a yellow solid (Conversion was found to be 66%, which consisted of: 73% yield of 2-chloro-5-fluoro-6-methoxyquinoline-3-carbaldehyde and 27% yield of 2-chloro-5,5-difluoro-6-oxo-5-hydroquinoline-3-carbaldehyde).

Experiment 4: 2-Chloro-6-methoxyquinoline-3-carbaldehyde (5.2 g, 23 mmol) and fluorine (345 mmol, 15 equiv.). Gave a yellow solid 5.36 g, analytical data comparable to that obtained previously from a pure sample. Conversion was found to be 100 %, which consisted of 100% 2-chloro-5,5-difluoro-6-oxo-5-hydroquinoline-3-carbaldehyde (96 % isolated yield) No further purification was necessary.

Experiment 5: 2-Chloro-6-methoxyquinoline-3-carbaldehyde (10.4 g, 47 mmol) was dissolved in sulfuric acid (150 ml); fluorine (707 mmol, 15 equiv.). Gave a yellow solid 10.23 g, analytical data comparable to that obtained previously from a pure sample. Conversion was found to be 100%, which consisted of 100% 2-chloro-5,5-difluoro-6-oxo-5-hydroquinoline-3-carbaldehyde (89 % isolated yield) No further purification was necessary.

Purification was achieved using chromatography on silica, 7: 3 hexane: diethyl ether as elutant to remove faster moving minor components; followed by chromatography on silica, dichloromethane as elutant. Crystals of 2-chloro-5-fluoro-6-methoxyquinoline-3-carbaldehyde were grown by the slow diffusion of hexane into a dichloromethane solution of 2-chloro-5-fluoro-6-methoxyquinoline-3-carbaldehyde, followed by the slow evaporation of the resultant dichloromethane/ hexane solution.

2-chloro-5-fluoro-6-methoxyquinoline-3-carbaldehyde (21): Yellow solid; 0.25 g; m.p. 146-147°C; $\delta^1\text{H}$ (500 MHz; CDCl_3) 10.52 (s, 1H, CHO), 8.91 (s, 1H, H_4), 7.83 (d, 1H, $^3\text{J}_{\text{HH}}$ 9.9, H_8), 7.66 (t, 1H, $^3\text{J}_{\text{HH}}$ $^4\text{J}_{\text{HF}}$ 9.0, H_7), 4.06 (s, 3H, OMe); $\delta^{19}\text{F}$ (376 MHz; CDCl_3) -141.8 (d, $^4\text{J}_{\text{HF}}$ 8.6, F_5); $\delta^{13}\text{C}$ (126 MHz; CDCl_3) 188.6 (m, C_3), 148.5 (s, CHO), 146.7 (d, $^1\text{J}_{\text{CF}}$ 257.3, C_5), 144.4 (d, $^2\text{J}_{\text{CF}}$ 8.7, C_6), 143.6 (s, C_2), 133.2 (d, $^4\text{J}_{\text{CF}}$ 4.5, C_4), 126.4 (d, $^3\text{J}_{\text{CF}}$ 2.3, $\text{C}_{8\alpha}$), 124.6 (d, $^4\text{J}_{\text{CF}}$ 4.5, C_8), 122.7 (d, $^3\text{J}_{\text{CF}}$ 2.8, C_7), 118.3 (d, $^2\text{J}_{\text{CF}}$ 13.7, $\text{C}_{4\alpha}$), 57.5 (d, $^4\text{J}_{\text{CF}}$ 1.0, OMe); ν_{max} (KBr disc)/ cm^{-1} 3077, 3057, 3002, 2953, 2881, 1693, 1635, 1581, 1558, 1504; m/z (EI^+) 241 (M^+ [^{37}Cl], 75 %), 240 (66), 239 (M^+ [^{35}Cl], 100), 241 (75), 238 (74), 224 (78), 196 (82), 175 (86), 168 (70), 132 (86); found C, 54.87; H, 2.91; N, 5.80. $\text{C}_{11}\text{H}_7\text{ClFNO}_2$ requires C, 55.14; H, 2.94; N, 5.85%; X-ray crystallography (selected data) Temp. 120(2) K, $\lambda = 0.71073 \text{ \AA}$, Monoclinic, $P2_1/c$ (No. 14), $a = 3.8149(4) \text{ \AA}$, $b = 20.997(2) \text{ \AA}$, $c = 12.275(1) \text{ \AA}$, $\alpha=90^\circ$, $\beta=91.12(1)^\circ$, $\gamma=90^\circ$, $V = 978.38(16) \text{ \AA}^3$, Density (calc.) = 1.627 g/cm^3 , $R(\text{int}) = 0.0482$, Crystal size = 0.41 x 0.12 x 0.08 mm^3 , $R1 = 0.038$, $wR2 = 0.097$.

2-chloro-5,5-difluoro-6-oxo-5-hydroquinoline-3-carbaldehyde (22): Yellow solid; 1.30 g; m.p. 122-123°C; $\delta^1\text{H}$ (500 MHz; CDCl_3) 10.45 (s, 1H, CHO), 8.58 (s, 1H, H_4), 7.64 (d, 1H, $^3\text{J}_{\text{HH}}$ 10.5, H_8), 6.64 (dt, 1H, $^3\text{J}_{\text{HH}}$ 10.0 $^4\text{J}_{\text{HF}}$ 2.5, H_7); $\delta^{19}\text{F}$ (376 MHz; CDCl_3) -102.4 (s, 2F, F_5); $\delta^{13}\text{C}$ (126 MHz; CDCl_3) 187.2 (m, C_3), 184.9 (t, $^2\text{J}_{\text{CF}}$ 24.3, C_6), 156.1 (s, CHO), 153.3 (t, $^3\text{J}_{\text{CF}}$ 5.9, $\text{C}_{8\alpha}$), 143.9 (s, C_8), 136.7 (t, $^3\text{J}_{\text{CF}}$ 2.3, C_4), 130.0 (t, $^3\text{J}_{\text{CF}}$ 2.8, C_7), 129.1 (t, $^2\text{J}_{\text{CF}}$ 25.1, $\text{C}_{4\alpha}$), 128.5 (s, C_2), 104.1 (t, $^1\text{J}_{\text{CF}}$ 248.1, C_5); ν_{max} (KBr disc) / cm^{-1} 3049, 2962, 1699, 1587, 1557; m/z (EI^+) 245 (M^+ [^{37}Cl], 74 %), 243 (M^+ [^{35}Cl], 100), 217 (60), 216 (67), 215 (80), 214 (97), 186 (86), 179 (51), 152 (68), 151 (88), 125 (65), 100 (52), 99 (67), 75 (81); found C, 49.13; H, 1.59; N, 5.71. $\text{C}_{10}\text{H}_4\text{ClF}_2\text{NO}$ requires C, 49.31; H, 1.66; N, 15.60 %; X-ray crystallography (selected data) Temp. 120(2) K, $\lambda =$

0.71073 Å, Monoclinic, $P2_1/c$ (No. 14), $a = 8.893(2)$ Å, $b = 6.105(2)$ Å, $c = 17.259(4)$ Å, $\alpha=90^\circ$, $\beta=91.56(1)^\circ$, $\gamma=90^\circ$, $V = 936.7(4)$ Å³, Density (calc.) = 1.727 g/cm³, $R(\text{int}) = 0.020$, Crystal size = 0.28 x 0.45 x 0.60 mm³, $R1 = 0.028$, $wR2 = 0.079$.

7.3.6 Direct Fluorination of 6-Methoxy-8-nitroquinoline (23)

Experiment 1: 6-Methoxy-8-nitroquinoline (0.5 g, 2.5 mmol) and fluorine (22 mmol, 9 equivalents). Gave a yellow solid 0.38 g; Conversion was found to be 56%, which consisted of 99% 5-fluoro-6-methoxy-8-nitroquinoline (As compared to literature data. 23, 219).

Experiment 2: 6-Methoxy-8-nitroquinoline (0.5 g, 2.5 mmol) was dissolved sulfuric acid (15 ml)/ PP11 (85 ml); fluorine (36 mmol, 14 equivalents). Gave a yellow/ orange solid 0.45 g; Conversion was found to be 59%, which consisted of 100% 5-fluoro-6-methoxy-8-nitroquinoline.

Experiment 3: 6-Methoxy-8-nitroquinoline (0.5 g, 2.5 mmol) was dissolved sulfuric acid (15 ml)/ PP11 (85 ml); fluorine (59 mmol, 23 equivalents). Gave a yellow/ orange solid 0.11 g; Conversion and yield were not calculated, due to the small amount of material recovered, although conversion is thought to be high.

Experiment 4: 6-Methoxy-8-nitroquinoline (0.5 g, 2.5 mmol) was dissolved sulfuric acid (15 ml)/ PP11 (85 ml); fluorine (17 mmol, 4 equivalents). Gave a yellow solid 0.97 g; Conversion was found to be 22%, which consisted of 100% 5-fluoro-6-methoxy-8-nitroquinoline.

Purification was achieved using chromatography on silica, 9: 1 diethyl ether: hexane as elutant.

5-Fluoro-6-methoxy-8-nitroquinoline (24): Yellow solid; 0.28 g; m.p. 154-155°C; $\delta^1\text{H}$ (400 MHz; CDCl_3) 9.01 (dd, 1H, $^3\text{J}_{\text{HH}} 4.4$ $^4\text{J}_{\text{HH}} 1.6$, H₂), 8.44 (d, 1H, $^3\text{J}_{\text{HH}} 8.4$ $^4\text{J}_{\text{HH}} 1.6$, H₄), 8.01 (d, 1H, $^4\text{J}_{\text{HF}} 8.0$, H₇), 7.57 (dd, 1H, $^3\text{J}_{\text{HH}} 8.8$ $^3\text{J}_{\text{HH}} 4.4$, H₃), 4.01 (d, 3H, $^5\text{J}_{\text{HF}} 0.8$, OMe); $\delta^{19}\text{F}$ (376 MHz; CDCl_3) -136.5 (d, $^4\text{J}_{\text{HF}} 7.9$, F₅); $\delta^{13}\text{C}$ (100 MHz; CDCl_3) 151.4 (s, C₂), 147.2 (d, $^1\text{J}_{\text{CF}} 259.7$, C₅), 143.6 (s, C₈), 142.1 (d, $^2\text{J}_{\text{CF}} 10.6$, C₆), 134.8 (d, $^3\text{J}_{\text{CF}} 2.8$, C_{8 α}), 128.4 (d, $^3\text{J}_{\text{CF}} 5.1$, C₄), 122.8 (d, $^4\text{J}_{\text{CF}} 3.6$, C₃), 119.9 (d, $^2\text{J}_{\text{CF}} 14.2$, C_{4 α}), 114.4 (d, $^3\text{J}_{\text{CF}} 3.6$, C₇), 57.8 (s, OMe); ν_{max} (KBr disc)/cm⁻¹ 3091, 2991, 2949, 2857, 1643, 1597, 1561, 1536; m/z (EI⁺) 222 (M⁺ 100 %), 192 (84), 133 (52); found C, 53.76; H,

3.01; N, 12.36. $C_{10}H_7FNO_3$ requires C, 54.06; H, 3.17; N, 12.61 %; X-ray crystallography (selected data) Temp. 120(2) K, $\lambda = 0.71073 \text{ \AA}$, Monoclinic, $P2_1/c$ (No. 14), $a = 7.416(1) \text{ \AA}$, $b = 16.246(6) \text{ \AA}$, $c = 8.008(1) \text{ \AA}$, $\alpha = 90^\circ$, $\beta = 108.19(2)^\circ$, $\gamma = 90^\circ$, $V = 916.6(4) \text{ \AA}^3$, Density (calc.) = 1.610 g/cm^3 , $R(\text{int}) = 0.0295$, Crystal size = $0.58 \times 0.33 \times 0.1 \text{ mm}^3$, $R1 = 0.033$, $wR2 = 0.097$.

7.3.7 Direct Fluorination of 6-Chloroquinoline (26)

6-Chloroquinoline (2.35 g, 14 mmol) and fluorine (168 mmol, 12 equivalents). Gave a dark brown oil 3.29 g. Conversion was found to be 59%, which consisted of: 79% yield of 6-chloro-5-fluoroquinoline, and 5% yield of 6-chloro-5,8-difluoroquinoline.

Purification was achieved using chromatography on silica, diethyl ether as elutant.

6-Chloro-5-fluoroquinoline (27): White solid; 0.1 g; $\delta^1\text{H}$ (500 MHz; CDCl_3) 8.94 (dd, 1H, $^3J_{\text{HH}} 4.0$ $^4J_{\text{HH}} 1.5$, H₂), 8.39 (dm, 1H, $^3J_{\text{HH}} 8.5$, H₄), 7.86 (dm, 1H, $^3J_{\text{HH}} 9.0$, H₈), 7.65 (dd, 1H, $^3J_{\text{HH}} 9.0$ $^4J_{\text{HF}} 8.0$, H₇), 7.48 (dd, 1H, $^3J_{\text{HH}} 8.5$ $^3J_{\text{HF}} 4.5$, H₃); $\delta^{19}\text{F}$ (470 MHz; CDCl_3) -124.2 (s, F₅); $\delta^{13}\text{C}$ (126 MHz; CDCl_3) 152.9 (d, $^1J_{\text{CF}} 257.5$, C₅), 151.2 (d, $^5J_{\text{CF}} 4.5$, C₂), 147.2 (d, $^3J_{\text{CF}} 2.4$, C_{8 α}), 130.3 (d, $^3J_{\text{CF}} 2.9$, C₇), 128.8 (d, $^4J_{\text{CF}} 4.0$, C₄), 126.1 (d, $^4J_{\text{CF}} 4.5$, C₈), 121.7 (d, $^4J_{\text{CF}} 7.9$, C₃), 119.4 (d, $^2J_{\text{CF}} 15.5$, C₆), 116.5 (d, $^2J_{\text{CF}} 16.5$ C_{4 α}); m/z (EI^+) 183 ($\text{M}^+\{^{37}\text{Cl}\}$, 53.35 %), 181 ($\text{M}^+\{^{35}\text{Cl}\}$, 100 %), 180 (66.45); $\text{M}^+, 183.006533$. $\text{C}_9\text{H}_5^{37}\text{ClFN}$ requires M, 183.006505; $\text{M}^+, 181.009566$. $\text{C}_9\text{H}_5^{35}\text{ClFN}$ requires M, 181.009540.

6-Chloro-5,8-difluoroquinoline (not isolated) (28): $\delta^{19}\text{F}$ (188 MHz; CDCl_3) -128.3 (dd, 1F, $^5J_{\text{FF}} 19.9$ $^3J_{\text{HF}} 9.6$, F₈), -129.1 (dd, 1F, $^5J_{\text{FF}} 19.9$ $^4J_{\text{HF}} 3.8$, F₅).

7.3.8 Direct Fluorination of 6-Methylquinoline (29)

Experiment 1: 6-Methylquinoline (2.86 g, 20 mmol) and fluorine (240 mmol, 12 equivalents). Gave a yellow oil (9.61 g, including dichloromethane washings). ^{19}F NMR results showed that a complex mixture was obtained with unknown products.

Experiment 2: 6-Methylquinoline (2.86 g, 20 mmol) and fluorine (65 mmol, 3.25 equivalents). Gave an orange oil (3.55 g). Conversion was found to be 54%, which consisted of: 75 % yield of 5-fluoro-6-methylquinoline, and 5% yield of 5,8-difluoro-6-methylquinoline.

Purification was achieved using chromatography on silica, 4: 1 diethyl ether: hexane as elutant.

5-Fluoro-6-Methylquinoline (30): Pale yellow oil; 0.2g; $\delta^1\text{H}$ (400 MHz; CDCl_3) 8.83 (br. m, 1H, H₂), 8.27 (dd, 1H, $^3\text{J}_{\text{HH}}$ 8.4 $^4\text{J}_{\text{HH}}$ 2.0, H₄), 7.77 (dd, 1H, $^3\text{J}_{\text{HH}}$ 8.8 H₃ $^5\text{J}_{\text{HF}}$ 2.0, H₈), 7.45 (td, 1H, $^4\text{J}_{\text{HH}}$ 8.0 $^4\text{J}_{\text{HF}}$ 3.2, H₇), 7.33 (m, 1H, H₃), 2.37 (m, 3H, Me); $\delta^{19}\text{F}$ (376 MHz; CDCl_3) -128.2 (d, $^4\text{J}_{\text{HF}}$ 8.6, F₅); $\delta^{13}\text{C}$ (100 MHz; CDCl_3) 156.6 (d, $^1\text{J}_{\text{CF}}$ 250.4, C₅), 149.9 (s, C₂), 147.2 (d, $^4\text{J}_{\text{CF}}$ 2.7, C_{8 α}), 131.9 (d, $^3\text{J}_{\text{CF}}$ 6.1, C₇), 128.5 (d, $^3\text{J}_{\text{CF}}$ 5.4, C₄), 124.3 (d, $^4\text{J}_{\text{CF}}$ 4.2, C₈), 120.8 (d, $^4\text{J}_{\text{CF}}$ 3.0, C₃), 119.4 (d, $^2\text{J}_{\text{CF}}$ 14.8, C_{4 α}), 118.6 (d, $^2\text{J}_{\text{CF}}$ 16.7, C₆), 14.0 (d, $^3\text{J}_{\text{CF}}$ 3.5, Me); ν_{max} (KBr plates)/ cm^{-1} 3071, 3023, 2959, 2926, 2863, 1639, 1595, 1568; m/z (EI⁺) 161 (M⁺, 91.76 %), 160 (100), 133 (62.75); found: [M + H]⁺ 162.0719. C₁₀H₉FN requires [M + H]⁺ 162.0719.

5,8-Difluoro-6-Methylquinoline (31): Pale yellow solid; 0.2 g; m.p. 81-82°C; $\delta^1\text{H}$ (400 MHz; CDCl_3) 8.93 (dm, 1H, $^3\text{J}_{\text{HH}}$ 4.4, H₂), 8.35 (dm, 1H, $^3\text{J}_{\text{HH}}$ 7.2, H₄), 7.48 (dd, 1H, $^3\text{J}_{\text{HH}}$ 8.4 $^3\text{J}_{\text{HH}}$ 4.4, H₃), 7.22 (dd, 1H, $^3\text{J}_{\text{HF}}$ 10.8 $^4\text{J}_{\text{HF}}$ 6.4, H₇), 2.43 (d, 3H, $^4\text{J}_{\text{HF}}$ 2.4, Me); $\delta^{19}\text{F}$ (376 MHz; CDCl_3) -131.6 (dd, 1F, $^5\text{J}_{\text{FF}}$ 21.8 $^4\text{J}_{\text{HF}}$ 10.2, F₈), -132.3 (dm, 1F, $^5\text{J}_{\text{FF}}$ 21.8, F₅); $\delta^{13}\text{C}$ (100 MHz; CDCl_3) 153.6 (dd, $^1\text{J}_{\text{CF}}$ 250.7 $^4\text{J}_{\text{CF}}$ 3.0, C₈), 150.7 (dd, $^1\text{J}_{\text{CF}}$ 246.2 $^4\text{J}_{\text{HF}}$ 3.1, C₅), 150.3 (d, $^4\text{J}_{\text{CF}}$ 1.6, C₂), 136.9 (dd, $^2\text{J}_{\text{CF}}$ 13.7 $^3\text{J}_{\text{CF}}$ 3.0, C_{8 α}), 128.9 (dd, $^3\text{J}_{\text{CF}}$ 4.6 $^4\text{J}_{\text{CF}}$ 2.7, C₄), 122.0 (d, $^4\text{J}_{\text{CF}}$ 2.3, C₃), 119.8 (d, $^2\text{J}_{\text{CF}}$ 18.3, C₆), 119.7 (dd, $^2\text{J}_{\text{CF}}$ 18.2 $^3\text{J}_{\text{CF}}$ 5.0, C₇), 115.6 (dd, $^2\text{J}_{\text{CF}}$ 20.8 $^3\text{J}_{\text{CF}}$ 5.6, C_{4 α}), 14.4 (d, $^3\text{J}_{\text{CF}}$ 3.4 $^4\text{J}_{\text{CF}}$ 0.8, Me); ν_{max} (KBr disc)/ cm^{-1} 3071, 3026, 2927, 2861, 1643, 1595, 1500; m/z (EI⁺) 179 (M⁺, 100 %), 178 (90.95); found: M⁺ 179.0549. C₁₀H₇F₂N requires M⁺ 179.0547.

6-Fluoro-6-methyl-6-hydroquinolin-5-one (32): $\delta^{19}\text{F}$ (188 MHz, CDCl_3) -158.1 (qd, $^3\text{J}_{\text{HF}}$ 21.8 $^3\text{J}_{\text{HF}}$ 8.3, F₆).

7.3.9 Direct Fluorination of 6-Nitroquinoline (33)

Experiment 1: 6-Nitroquinoline (7.83 g, 45 mmol) was dissolved in methanoic acid (150 ml); fluorine (143 mmol, 3 equiv.). The solution was cooled to 9 °C. Gave a yellow solid (6.8 g).

Experiment 2: 6-Nitroquinoline (3.50 g, 20 mmol) and fluorine (240 mmol, 12 equiv.). Gave a yellow oil (3.42 g). Conversion was found to be 13%, which consisted of 86% yield of 8-fluoro-6-nitroquinoline.

Experiment 3: 6-Nitroquinoline (2.8 g, 16 mmol) was dissolved in an oleum (10 ml)/PP11 (90 ml) medium; fluorine (240 mmol, 15 equiv) and cooled to 15°C. Gave 3.4 g of a yellow solid. Conversion was found to be 61%, which consisted of 59 % yield of 8-fluoro-6-nitroquinoline.

Experiment 4: 6-Nitroquinoline (2.8 g, 16 mmol) and fluorine (273 mmol, 18 equiv) at a rate of 25 mlmin⁻¹ and cooled to 15°C. Gave 2.0 g of a yellow solid. Conversion was found to be 41%, which consisted of 74% yield of 8-fluoro-6-nitroquinoline.

Experiment 5: 6-Nitroquinoline (2.8 g, 16 mmol) was dissolved in sulfuric acid (10 ml)/PP11 (90ml) medium; fluorine (192 mmol, 12 equiv) and cooled to 15°C. Gave 3.9 g of a yellow solid. Conversion was found to be 38%, which consisted of 78% yield of 8-fluoro-6-nitroquinoline.

Purification was achieved using chromatography on silica, 96:4 dichloromethane:methanol as elutant.

8-Fluoro-6-nitroquinoline (34): Yellow solid; 0.2 g; $\delta^1\text{H}$ (500 MHz; CDCl_3) 9.13 (dd, 1H, $^3\text{J}_{\text{HH}}$ 4.0 $^4\text{J}_{\text{HH}}$ 1.5, H₂), 8.62 (t, 1H, $^4\text{J}_{\text{HH}}$ $^5\text{J}_{\text{HF}}$ 2.0, H₅), 8.41 (dm, 1H, $^3\text{J}_{\text{HH}}$ 8.5, H₄), 8.17 (dd, 1H, $^3\text{J}_{\text{HF}}$ 10.0 $^4\text{J}_{\text{HH}}$ 2.5, H₇), 7.67 (dd, 1H, $^3\text{J}_{\text{HH}}$ 8.5 $^3\text{J}_{\text{HH}}$ 4.5, H₃); $\delta^{19}\text{F}$ (470 MHz; CDCl_3) -119.5 (d, $^3\text{J}_{\text{HF}}$ 9.9, F₈); $\delta^{13}\text{C}$ (100 MHz; CDCl_3) 158.0 (d, $^1\text{J}_{\text{CF}}$ 260.7, C₈), 153.8 (d, $^4\text{J}_{\text{CF}}$ 1.5, C₂), 145.0 (d, $^3\text{J}_{\text{CF}}$ 8.7, C₆), 140.8 (d, $^2\text{J}_{\text{CF}}$ 12.2, C_{8 α}), 137.7 (d, $^4\text{J}_{\text{CF}}$ 3.1, C₄), 128.2 (d, $^3\text{J}_{\text{CF}}$ 3.0, C_{4 α}), 123.9 (s, C₃), 120.0 (d, $^4\text{J}_{\text{CF}}$ 4.9, C₅), 108.0 (d, $^2\text{J}_{\text{CF}}$ 24.8, C₇); m/z (EI⁺) 192 (M⁺, 100 %), 146 (62), 134 (54), 126 (60); found: M⁺ 192.0336. C₉H₅FNO₂ requires M⁺ 192.0335; X-ray crystallography (selected data) Temp. 120(2) K, $\lambda = 0.71073 \text{ \AA}$, Triclinic, $P\bar{1}$ (No. 2), $a = 8.808(3) \text{ \AA}$, $b = 9.767(3) \text{ \AA}$, $c = 10.416(3) \text{ \AA}$, $\alpha = 86.12^\circ$, $\beta = 65.30^\circ$, $\gamma = 77.07^\circ$, $V = 793.1(4) \text{ \AA}^3$, Density (calc.) = 1.628 g/cm³, R(int) = 0.0284, Crystal size = 0.6 x 0.39 x 0.08 mm³, R1 = 0.049, wR2 = 0.130 {H atoms at C(3), C(5), C(13), C(15) partially substituted by fluorine. H/F ratio estimated as 93:7 at C(3) and C(13), 95:5 at C(5) and C(15)}.

7.3.10 Direct Fluorination of 4,7-Dichloroquinoline (35)

Experiment 1: 4,7-Dichloroquinoline (2.4 g, 15 mmol) was added to an oleum (15 ml)/PP11 (85 ml) medium; fluorine (180 mmol, 12 equiv.). Gave an orange solid (3.3 g). Conversion was found to be 62%, which consisted of: 46 % yield of 4,7-dichloro-8-fluoroquinoline and 11% 4,7-dichloro-5,8-difluoroquinoline.

Experiment 2: 4,7-Dichloroquinoline (2.6 g, 13 mmol) and fluorine (78 mmol, 6 equiv.). Gave a yellow solid 2.3 g. Conversion was found to be 19 %, which consisted of: 76% 4,7-dichloro-8-fluoroquinoline and 4% 4,7-dichloro-5,8-difluoroquinoline.

Purification was achieved using chromatography on silica, 2: 1 diethyl ether: hexane as elutant.

4,7-Dichloro-8-fluoroquinoline (36): White solid; 0.5 g; $\delta^1\text{H}$ (400 MHz; CDCl_3) 8.82 (d, 1H, $^3\text{J}_{\text{HH}}$ 4.0, H₂), 7.92 (dd, 1H, $^3\text{J}_{\text{HH}}$ 9.2 $^5\text{J}_{\text{HF}}$ 2.0, H₅), 7.58 (dd, 1H, $^3\text{J}_{\text{HH}}$ 9.2 $^4\text{J}_{\text{HF}}$ 6.4, H₆), 7.54 (d, 1H, $^3\text{J}_{\text{HH}}$ 4.4, H₃); $\delta^{19}\text{F}$ (376 MHz; CDCl_3) -124.5 (s, F₈); $\delta^{13}\text{C}$ (100 MHz; CDCl_3) 153.6 (d, $^1\text{J}_{\text{CF}}$ 257.5, C₈), 150.8 (s, C₂), 142.7 (d, $^4\text{J}_{\text{CF}}$ 3.8, C₄), 139.7 (d, $^3\text{J}_{\text{CF}}$ 11.4, C_{4 α}), 128.7 (s, C₅), 123.1 (s, C₃), 121.3 (d, $^2\text{J}_{\text{CF}}$ 16.3, C₇), 119.9 (d, $^3\text{J}_{\text{CF}}$ 6.0, C₆), 114.0 (d, $^2\text{J}_{\text{CF}}$ 27.3, C_{8 α}); m/z (EI⁺) 217 (M⁺ { $^{35},^{37}\text{Cl}$ }, 75 %), 215 (M⁺ { $^{35},^{35}\text{Cl}$ }, 100 %), 180 (91), 145 (69); M⁺ { $^{35},^{35}\text{Cl}$ }, 214.971234. C₉H₄³⁵Cl₂FN requires M, 214.970483; X-ray crystallography (selected data) Temp. 120(2) K, $\lambda = 0.71073 \text{ \AA}$, Orthorhombic, Pna2₁ (No. 33), a = 23.382(4) \AA , b = 3.7793(4) \AA , c = 9.6206(16) \AA , $\alpha=90^\circ$, $\beta=90^\circ$, $\gamma=90^\circ$, V = 850.1(2) \AA^3 , Density (calc.) = 1.711 g/cm³, R(int) = 0.0665, Crystal size = 0.52 x 0.12 x 0.01 mm³ {Solid solution of the target compound and the product of fluorination at C-5; 83.3(8) % and 16.7(8) % respectively}.

4,7-Dichloro-5,8-difluoroquinoline (not isolated) (37): $\delta^{19}\text{F}$ (376 MHz; CDCl_3) -114.8 (dd, 1F, $^5\text{J}_{\text{FF}}$ 20.3 $^3\text{J}_{\text{HF}}$ 11.7, F₅), 127.7 (d, 1F, $^5\text{J}_{\text{FF}}$ 20.3, F₈); m/z (EI⁺) 235 (M⁺ { $^{35},^{37}\text{Cl}$ }, 54 %), 233 (M⁺ { $^{35},^{35}\text{Cl}$ }, 100 %), 198 (67); M⁺ { $^{35},^{35}\text{Cl}$ }, 232.961345. C₉H₃³⁵Cl₂F₂N requires M, 232.961061.

7.3.11 Direct Fluorination of 2,7-Dimethylquinoline (38)

Experiment 1: 2,7-Dimethylquinoline (2.7 g, 17 mmol) and fluorine (43 mmol, 2.5 equiv.). Gave a yellow oil 4.9 g. Conversion was found to be 40%, which consisted of: 82% 8-fluoro-2,7-dimethylquinoline and 12% 5,8-difluoro-2,7-dimethylquinoline.

Experiment 2: 2,7-Dimethylquinoline (1.5 g, 10 mmol) and fluorine (50 mmol, 5 equiv.). Gave a yellow solid 1.5 g. Conversion was found to be 51%, which consisted of 61% 8-fluoro-2,7-dimethylquinoline and 15% 5,8-difluoro-2,7-dimethylquinoline.

Experiment 3: 2,7-Dimethylquinoline (1.5 g, 10 mmol) and fluorine (100 mmol, 10 equiv.). Gave a yellow oil 3.8 g. Conversion was found to be 62%, which consisted of 28% 8-fluoro-2,7-dimethylquinoline and 23% 5,8-difluoro-2,7-dimethylquinoline.

Purification was achieved using chromatography on silica; diethyl ether/ hexane (4: 1) was used as elutant.

8-Fluoro-2,7-dimethylquinoline (39): White solid; 0.47 g; m.p. 90-92°C; $\delta^1\text{H}$ (500 MHz; CDCl_3) 7.89 (dd, 1H, $^3\text{J}_{\text{HH}}$ 8.5 $^4\text{J}_{\text{HH}}$ 1.5, H₄), 7.34 (d, 1H, $^3\text{J}_{\text{HH}}$ 4.0, H₅), 7.20-7.14 (m, 2H, H₃ and H₆), 2.68 (s, 3H, 2-Me), 2.38 (d, 3H, $^4\text{J}_{\text{HF}}$ 2.5, 7-Me); $\delta^{19}\text{F}$ (376 MHz; CDCl_3) -131.8 (s, F₈); $\delta^{13}\text{C}$ (126 MHz; CDCl_3) 159.2 (d, $^4\text{J}_{\text{CF}}$ 6.0, C₂), 155.1 (d, $^1\text{J}_{\text{CF}}$ 251.0, C₈), 137.9 (d, $^2\text{J}_{\text{CF}}$ 11.9, C_{8 α}), 135.6 (d, $^4\text{J}_{\text{CF}}$ 3.4, C₄), 128.4 (d, $^3\text{J}_{\text{CF}}$ 4.8, C₆), 126.2 (d, $^3\text{J}_{\text{CF}}$ 2.4, C_{4 α}), 123.3 (d, $^2\text{J}_{\text{CF}}$ 15.8, C₇), 122.1 (d, $^4\text{J}_{\text{CF}}$ 5.3, C₅), 122.0 (s, C₃), 25.5 (s, 2-Me), 14.6 (d, $^3\text{J}_{\text{CF}}$ 4.3, 7-Me); ν_{max} (KBr plates)/ cm^{-1} 3050, 2923, 1636, 1603, 1501; m/z (EI⁺) 175 (M⁺, 100 %), 174 (79); M⁺, 175.079991. C₁₁H₁₀FN requires M, 175.079728; found C, 74.91; H, 5.59; N, 7.87. C₁₁H₁₀FN requires C, 75.41; H, 5.75; N, 7.99 %.

5,8-Difluoro-2,7-dimethylquinoline (40): White solid; 0.06 g; $\delta^1\text{H}$ (400 MHz; CDCl_3) 8.21 (d, 1H, $^3\text{J}_{\text{HH}}$ 8.8, H₄), 7.31 (d, 1H, $^3\text{J}_{\text{HH}}$ 8.8, H₃), 6.95 (dd, 1H, $^3\text{J}_{\text{HF}}$ 10.0 $^4\text{J}_{\text{HF}}$ 5.2, H₆), 2.78 (s, 3H, 2-Me), 2.46 (d, 3H, $^4\text{J}_{\text{HF}}$ 2.4, 7-Me); $\delta^{19}\text{F}$ (376 MHz; CDCl_3) -129.2 (dd, 1F, $^5\text{J}_{\text{FF}}$ 21.8 $^3\text{J}_{\text{HF}}$ 9.4, F₅), 135.9 (d, 1F, $^5\text{J}_{\text{FF}}$ 21.1, F₈); $\delta^{13}\text{C}$ (100 MHz; CDCl_3) 160.4 (s, C₂), 152.8 (dd, $^1\text{J}_{\text{CF}}$ 249.0 $^4\text{J}_{\text{CF}}$ 3.8, C₈), 151.4 (dd, $^1\text{J}_{\text{CF}}$ 246.3 $^4\text{J}_{\text{CF}}$ 3.8, C₅), 137.9 (dd, $^2\text{J}_{\text{CF}}$ 13.7 $^3\text{J}_{\text{CF}}$ 3.8, C_{8 α}), 129.3 (t, $^3\text{J}_{\text{CF}}$ $^4\text{J}_{\text{CF}}$ 2.7, C₄), 123.1 (dd, $^2\text{J}_{\text{CF}}$ 18.0 $^3\text{J}_{\text{CF}}$ 8.4, C₇), 122.1 (d, $^4\text{J}_{\text{CF}}$ 2.2, C₃), 116.3 (dd, $^2\text{J}_{\text{CF}}$ 18.6 $^3\text{J}_{\text{CF}}$ 2.3, C_{4 α}), 111.5 (dd, $^2\text{J}_{\text{CF}}$ 21.4 $^3\text{J}_{\text{CF}}$ 4.6, C₆), 25.6 (s, 2-Me), 14.9 (d, $^3\text{J}_{\text{CF}}$ 3.1, 7-Me); m/z (EI⁺) 193 (M⁺, 100 %); M⁺, 193.070315. C₁₁H₉F₂N requires M, 193.070306.

7.3.12 Direct Fluorination of 8-Methylquinoline (41)

Experiment 1: 8-Methylquinoline (2.86 g, 20 mmol) and fluorine (65 mmol, 3.25 equivalents). Gave an orange oil (3.98 g). Conversion was found to be 26%, which

consisted of: 68% yield of 5-fluoro-8-methylquinoline and 16% yield of 8-fluoro-8-methyl-8-hydroquinoline-5-one.

Experiment 2: 8-Methylquinoline (2.02 g, 14 mmol) and fluorine (170 mmol, 12 equivalents). Gave an orange oil (4.76 g). 47% Conversion was found to be 47%, which consisted of: 12 % yield of 5-fluoro-8-methylquinoline and 58 % yield of 8-fluoro-8-methyl-8-hydroquinoline-5-one.

Experiment 3: 8-Methylquinoline (1.86 g, 13 mmol) and fluorine (156 mmol, 12 equivalents). Periodically, over twelve hours, fluorine was stopped and the reaction vessel purged for a few minutes with dry nitrogen. Using a 1 ml syringe, a 1 ml sample was removed from the reaction vessel under a nitrogen atmosphere, and the ^{19}F NMR taken. The flow of fluorine was initiated immediately after sample removal.

Purification was achieved using chromatography on silica, 4: 1 diethyl ether: hexane as elutant.

5-Fluoro-8-methylquinoline (42): Colourless oil; 0.1 g; $\delta^1\text{H}$ (400 MHz; CDCl_3) 8.96 (dd, 1H, $^4\text{J}_{\text{HH}}$ 4.4 $^3\text{J}_{\text{HH}}$ 2.0, H₂), 8.38 (dd, 1H, $^4\text{J}_{\text{HF}}$ 8.4 $^3\text{J}_{\text{HH}}$ 1.6, H₄), 7.43 (m, 2H, H₃ and H₇), 7.08 (dd, 1H, $^3\text{J}_{\text{HH}}$ 8.0 $^3\text{J}_{\text{HF}}$ 9.6, H₆), 2.74 (s, 3H, Me); $\delta^{19}\text{F}$ (376 MHz; CDCl_3) -126.9 (m, F₅); $\delta^{13}\text{C}$ (100 MHz; CDCl_3) 156.2 (d, $^1\text{J}_{\text{CF}}$ 250.7, C₅), 149.9 (s, C₂), 147.3 (d, $^4\text{J}_{\text{CF}}$ 2.7, C₈), 132.7 (d, $^3\text{J}_{\text{CF}}$ 4.5, C_{8 α}), 129.3 (d, $^3\text{J}_{\text{CF}}$ 5.0, C₄), 128.4 (d, $^3\text{J}_{\text{CF}}$ 8.4, C₇), 120.7 (d, $^4\text{J}_{\text{CF}}$ 3.0, C₄), 118.9 (d, $^2\text{J}_{\text{CF}}$ 16.3, C_{4 α}), 109.4 (d, $^2\text{J}_{\text{CF}}$ 18.6, C₆), 17.6 (s, Me); ν_{max} (KBr disc)/ cm^{-1} 3068, 3012, 2957, 2923, 2891, 2851, 1629, 1597, 1579; m/z (EI⁺) 161 (M⁺, 100 %), 160 (76.85); found: [M + H]⁺ 162.0719. C₁₀H₉FN requires [M + H]⁺ 162.0719.

8-Fluoro-8-methyl-8-hydroquinolin-5-one (43): White solid; m.p. 68-70°C; 0.3 g; $\delta^1\text{H}$ (400 MHz; CDCl_3) 8.89 (dd, 1H, $^3\text{J}_{\text{HH}}$ 4.8 $^4\text{J}_{\text{HH}}$ 2.0, H₂), 8.36 (ddd, 1H, $^3\text{J}_{\text{HH}}$ 7.6 $^4\text{J}_{\text{HH}}$ 1.6 $^5\text{J}_{\text{HF}}$ 0.8, H₄), 7.49 (ddd, 1H, $^3\text{J}_{\text{HH}}$ 8.0 $^3\text{J}_{\text{HH}}$ 4.8 $^6\text{J}_{\text{HF}}$ 0.8, H₃), 7.16 (dd, 1H, $^3\text{J}_{\text{HH}}$ 10.4 $^3\text{J}_{\text{HF}}$ 7.2, H₇), 6.44 (dd, 1H, $^3\text{J}_{\text{HH}}$ 10.4 $^4\text{J}_{\text{HF}}$ 1.2, H₆), 1.90 (d, 3H, $^3\text{J}_{\text{HF}}$ 21.2, Me); $\delta^{19}\text{F}$ (376 MHz; CDCl_3) -144.4 (qd, $^3\text{J}_{\text{HF}}$ 20.3 $^3\text{J}_{\text{HF}}$ 5.6, F₈); $\delta^{13}\text{C}$ (100 MHz; CDCl_3) 183.9 (d, $^4\text{J}_{\text{CF}}$ 3.4, C₅), 158.6 (d, $^2\text{J}_{\text{CF}}$ 16.3, C_{8 α}), 153.5 (d, $^4\text{J}_{\text{CF}}$ 1.6, C₂), 147.4 (d, $^2\text{J}_{\text{CF}}$ 22.0, C₇), 134.6 (s, C₄), 128.1 (d, $^3\text{J}_{\text{CF}}$ 7.6, C₆), 125.2 (d, $^3\text{J}_{\text{CF}}$ 2.7, C_{4 α}), 124.4 (d, $^5\text{J}_{\text{CF}}$ 1.9, C₃), 87.4 (d, $^1\text{J}_{\text{CF}}$ 169.9, C₈), 26.3 (d, $^2\text{J}_{\text{CF}}$ 28.8, Me); ν_{max} (KBr disc)/ cm^{-1} 3087, 3061, 3054, 3006,

2990, 2940, 1671, 1633, 1583; m/z (EI^+) 177 (M^+ , 29.76 %), 159 (100), 158 (78.57); ($C_{10}H_8FNO$ requires 67.79 C, 4.55 H, 7.91 N; found 67.49 C, 4.51 H, 7.97 N %); X-ray crystallography (selected data) Temp. 110(2) K, $\lambda = 0.71073 \text{ \AA}$, Orthorhombic, Pbcn (No. 61), $a = 11.448(1) \text{ \AA}$, $b = 6.7394(4) \text{ \AA}$, $c = 21.629(2) \text{ \AA}$, $\alpha=90^\circ$, $\beta=90^\circ$, $\gamma=90^\circ$, $V = 1668.7(2) \text{ \AA}^3$, Density (calc.) = 1.410 g/cm^3 , $R(\text{int}) = 0.0376$, Crystal size = $0.17 \times 0.19 \times 0.66 \text{ mm}^3$, $R1 = 0.042$, $wR2 = 0.115$.

Attempted Nucleophilic Attack by Sodium Methoxide

5-Fluoro-8-methylquinoline (62 mg, 0.09 mmol) was dissolved in anhydrous methanol (10 ml). Sodium methoxide (0.05 g, 0.93 mmol) was then added and the mixture heated under reflux for 24 hours. The reaction was poured onto water (200 ml), extracted with dichloromethane, and the combined extracts dried over magnesium sulfate. Solvent was removed by rotary evaporation to leave a yellow oil (59 mg) Analysis by ^{19}F NMR and GCMS showed that no products arising from nucleophilic displacement of fluorine by methoxide were present in the product.

7.3.13 Direct Fluorination of Isoquinoline (44)

Experiment 1 (Acetonitrile): Isoquinoline (2.0 g, 15 mmol) and fluorine (47 mmol). Gave a dark oil 4.12 g. Conversion was not determined due to significant tar being present in the crude reaction mixture. Analysis of the ^{19}F NMR showed that a complex mixture of uncharacterised products was produced.

Experiment 2: Isoquinoline (2.0 g, 16 mmol) and fluorine (96 mmol, 6 equivalents). Gave a dark oil 3.87 g; Conversion was found to be 45%, which consisted of: 63% 5-/ 8-fluoroisoquinoline (1: 1 ratio) and 20% 5,8-difluoroisoquinoline.

Experiment 3: Isoquinoline (2.6 g, 20 mmol) and fluorine (240 mmol, 12 equivalents). Gave a dark oil 3.75 g; Conversion was found to be 56%, which consisted of: 47% 5-/ 8-fluoroisoquinoline (1: 1 ratio) and 32% 5,8-difluoroisoquinoline

Experiment 4: Isoquinoline (2.5 g, 19 mmol) and fluorine (39 mmol, 2 equivalents). Gave a dark oil 2.71 g; Conversion was found to be 12%, which consisted of: 80% 5-/ 8-fluoroisoquinoline (1: 1 ratio) and 8% 5,8-difluoroisoquinoline.

Experiment 5: Isoquinoline (5.0 g, 39 mmol) and fluorine (233 mmol, 6 equivalents). Gave a dark oil 8.81 g; Conversion was found to be 52%, which consisted of: 55% 5-/8-fluoroisoquinoline (1: 1 ratio) and 17% 5,8-difluoroisoquinoline.

Purification was achieved using chromatography on silica 4: 1 diethyl ether as elutant; 5,8-difluoroisoquinoline was further purified by sublimation.

5-Fluoroisoquinoline (not isolated) (45): $\delta^{19}\text{F}$ (376 MHz; CDCl_3); -123.6 (dd, $^3\text{J}_{\text{HF}}$ 10.2 $^4\text{J}_{\text{HF}}$ 5.3, F₅); m/z (EI⁺) 147 (M⁺, 100 %).

7-Fluoroisoquinoline (not isolated) (46): $\delta^{19}\text{F}$ (376 MHz; CDCl_3) -111.5 (td, $^3\text{J}_{\text{HF}}$ $^4\text{J}_{\text{HF}}$ 9.0 $^4\text{J}_{\text{HF}}$ 5.3, F₇).

8-Fluoroisoquinoline (47): Yellow oil; 0.12 g; $\delta^1\text{H}$ (500 MHz; CDCl_3) 9.51 (s, 1H, H₁), 8.58 (d, 1H, $^3\text{J}_{\text{HH}}$ 6.0, H₃), 7.60 (d, 1H, $^3\text{J}_{\text{HH}}$ 5.5, H₄), 7.53-7.59 (m, 2H, H₅ and H₆), 7.18 (m, 1H, H₇); $\delta^{19}\text{F}$ (376 MHz; CDCl_3) -123.4 (m, F₈); $\delta^{13}\text{C}$ (126 MHz; CDCl_3) 158.8 (d, $^1\text{J}_{\text{CF}}$ 256.8, C₈), 145.9 (d, $^3\text{J}_{\text{CF}}$ 4.8, C₁), 143.7 (d, $^5\text{J}_{\text{CF}}$ 1.0, C₃), 136.7 (d, $^3\text{J}_{\text{CF}}$ 3.8, C_{4a}), 130.4 (d, $^3\text{J}_{\text{CF}}$ 8.7, C₆), 122.1 (d, $^4\text{J}_{\text{CF}}$ 4.4, C₅), 119.6 (d, $^4\text{J}_{\text{CF}}$ 2.8, C₄), 118.8 (d, $^2\text{J}_{\text{CF}}$ 15.4, C_{8a}), 110.8 (d, $^2\text{J}_{\text{CF}}$ 19.3, C₇); ν_{max} (KBr plates)/cm⁻¹ 3053, 1639, 1585, 1573, 1500; m/z (EI⁺) 147 (M⁺, 100 %), 50 (61); M⁺, 147.0485. C₉H₆FN requires M⁺, 147.0484.

5,8-Difluoroisoquinoline (48): Pale yellow solid; 0.40 g; m.p. 79-80°C; $\delta^1\text{H}$ (500 MHz; CDCl_3) 9.51 (s, 1H, H₁), 8.67 (d, 1H, $^3\text{J}_{\text{HH}}$ 6.0, H₃), 7.84 (d, 1H, $^3\text{J}_{\text{HH}}$ 6.0, H₄), 7.28 (td, 1H, $^3\text{J}_{\text{HF}}$ $^3\text{J}_{\text{HH}}$ 9.0 $^4\text{J}_{\text{HF}}$ 4.0, H₇), 7.15 (td, 1H, $^3\text{J}_{\text{HF}}$ $^3\text{J}_{\text{HH}}$ 9.0 $^4\text{J}_{\text{HF}}$ 4.0, H₆); $\delta^{19}\text{F}$ (376 MHz; CDCl_3) -128.2 (m, 2F, F₅ and F₈); $\delta^{13}\text{C}$ (126 MHz; CDCl_3) 154.9 (dd, $^1\text{J}_{\text{CF}}$ 249.6 $^4\text{J}_{\text{CF}}$ 6.3, C₈), 153.4 (dd, $^1\text{J}_{\text{CF}}$ 246.7 $^4\text{J}_{\text{CF}}$ 13.0, C₅), 146.0 (dd, $^4\text{J}_{\text{CF}}$ 3.9 $^5\text{J}_{\text{CF}}$ 2.4, C₁), 144.3 (s, C₃), 126.8 (dd, $^2\text{J}_{\text{CF}}$ 20.1 $^3\text{J}_{\text{CF}}$ 4.8, C_{4a}), 119.2 (dd, $^2\text{J}_{\text{CF}}$ 17.4 $^3\text{J}_{\text{CF}}$ 5.3, C_{8a}), 113.5 (dd, $^2\text{J}_{\text{CF}}$ 21.7 $^3\text{J}_{\text{CF}}$ 9.1, C₇), 113.1 (t, $^3\text{J}_{\text{CF}}$ $^4\text{J}_{\text{CF}}$ 2.4, C₄), 110.4 (dd, $^2\text{J}_{\text{CF}}$ 21.7 $^3\text{J}_{\text{CF}}$ 8.2, C₆); ν_{max} (KBr disc)/cm⁻¹ 3055, 1683, 1649, 1581, 1590, 1579; m/z (EI⁺) 165 (M⁺, 100 %), 138 (76); M⁺, 165.038940. C₉H₅F₂N requires M⁺, 165.039006.

Chapter 8.0: Experimental Section to Chapter 3.0

8.1 General Procedure

The reactions below follow the procedure described, unless otherwise stated. Reaction apparatus was purged with nitrogen thoroughly, before and after fluorination. The reaction was cooled in a salt water bath to 0-1°C by an external cryostat. Reactant was charged into a glass reaction vessel containing sulfuric acid (> 98%) (100 ml). The solution was rapidly stirred using an overhead stirrer, typically at 350 revolutions min⁻¹. Fluorine, diluted to 10% with dry nitrogen (v:v) was bubbled through the solution at a rate of 50 mlmin⁻¹ (13 mmolh⁻¹). Conversions and yields were determined from the ¹⁹F NMR of the crude product, by comparison of the peak integrals with the integral of an internal reference (trifluoromethylbenzene). A typical work-up involves pouring the reaction onto ice-slush (1000 ml), followed by neutralisation with sodium hydrogencarbonate. The mixture was subsequently filtered, and the filtrate extracted with dichloromethane; the combined extracts were dried over magnesium sulfate. Solvent was removed by rotary evaporation to leave crude reaction product.

8.1.1 Direct fluorination of 2H-chromen-2-one (49)

Experiment 1: 2H-Chromen-2-one (5.0 g, 34 mmol) and methanoic acid cooled to 15 °C; fluorine (68 mmol, 2 equiv.). Gave an orange solid 5.74 g. Homogenised to 27.32 g in dichloromethane.

Conversion determined to be 49%; of which, 6-fluoro-2H-chromen-2-one 29%, 8-fluoro-2H-chromen-2-one 11%, 3,4-difluorochroman-2-one 10%, and 3-fluoro-2-oxochroman-4-yl methanoate 22%.

Experiment 2: 2H-Chromen-2-one (5.0 g, 34 mmol) cooled to 15 °C and fluorine (68 mmol, 2 equiv.). Gave an orange solid 6.16 g. Homogenised to 23.81 g in dichloromethane.

Conversion determined to be 38%; of which, 6-fluoro-2H-chromen-2-one 31%, 7-fluoro-2H-chromen-2-one 30%, 8-fluoro-2H-chromen-2-one 17%, 5,6-difluoro-2H-chromen-2-one 5%, and 6,8-difluoro-2H-chromen-2-one 7%.

Experiment 3: 2H-Chromen-2-one (5.0 g, 34 mmol) cooled to 15 °C and fluorine (204 mmol, 6 equiv.). Gave an orange oil 11.51 g. Homogenised to 24.91 g in dichloromethane.

Conversion determined to be 76%; of which, 6-fluoro-2H-chromen-2-one 16%, 7-fluoro-2H-chromen-2-one 18%, 8-fluoro-2H-chromen-2-one 7%, 5,6-difluoro-2H-chromen-2-one 14%, and 6,8-difluoro-2H-chromen-2-one 15%.

Experiment 4: 2H-Chromen-2-one (5.0 g, 34 mmol) and fluorine (204 mmol, 6 equiv.). Homogenised to 27.32 g in dichloromethane; gave yellow solution.

Conversion determined to be 53%; of which, 6-fluoro-2H-chromen-2-one 27%, 7-fluoro-2H-chromen-2-one 28%, 8-fluoro-2H-chromen-2-one 13%, 5,6-difluoro-2H-chromen-2-one 13%, and 6,8-difluoro-2H-chromen-2-one 25%.

Experiment 5: 2H-Chromen-2-one (2.5 g, 17 mmol) and fluorine (204 mmol, 12 equiv.). Homogenised to 30.65 g in dichloromethane; gave a yellow solution.

Conversion determined to be 69%; of which, 6-fluoro-2H-chromen-2-one 20%, 7-fluoro-2H-chromen-2-one 22%, 8-fluoro-2H-chromen-2-one 8%, 5,6-difluoro-2H-chromen-2-one 15%, and 6,8-difluoro-2H-chromen-2-one 17%.

Experiment 6: 2H-Chromen-2-one (2.5 g, 17 mmol) and fluorine (204 mmol, 12 equiv.). Homogenised to 17.59 g in dichloromethane; gave a yellow solution.

Conversion determined to be 72%; of which, 6-fluoro-2H-chromen-2-one 18%, 7-fluoro-2H-chromen-2-one 20%, 8-fluoro-2H-chromen-2-one 7%, 5,6-difluoro-2H-chromen-2-one 16%, and 6,8-difluoro-2H-chromen-2-one 17%.

Purification of 5,6-difluoro-2H-chromen-2-one and 8-fluoro-2H-chromen-2-one was achieved by chromatography on silica, diethyl ether/ hexane (2:1) as elutant; further purification on some of the fractions by preparative HPLC (using a 21.4 cm Hypersil (semi) preparative column, water/ methanol (3:2) as elutant, 10mlmin⁻¹ flow rate.). Crystals suitable for X-ray analysis were obtained by the slow evaporation of the water/ methanol solvent.

6-Fluoro-2H-chromen-2-one (not isolated) (50): $\delta^{19}\text{F}$ (376MHz; CDCl_3) -119.9 (dd, $^3\text{J}_{\text{HF}}$ 8.3 $^3\text{J}_{\text{HF}}$ 6.8, F₆).

7-Fluoro-2H-chromen-2-one (not isolated) (51): $\delta^{19}\text{F}$ (376MHz; CDCl_3) -117.9 (td, $^3\text{J}_{\text{HF}}$ 8.3 $^4\text{J}_{\text{HF}}$ 5.3, F₇).

8-Fluoro-2H-chromen-2-one (52): $\delta^{19}\text{F}$ (376MHz; CDCl_3) -134.0 (dd, $^3\text{J}_{\text{HF}}$ 9.4 $^4\text{J}_{\text{HF}}$ 4.5, F₈); X-ray crystallography (selected data) Temp. 120(2) K, $\lambda = 0.71073$ Å, Monoclinic, Pc, $a = 3.7260(2)$ Å, $b = 8.2531(4)$ Å, $c = 11.3619(5)$ Å, $\alpha = 90^\circ$, $\beta = 96.227(2)^\circ$, $\gamma = 90^\circ$, $V = 347.33(3)$ Å³, Density (calc.) = 1.569 g/cm³, R(int) = 0.0187, Crystal size = 0.82 x 0.08 x 0.07 mm³, R1 = 0.034, wR2 = 0.094.

5,6-Difluoro-2H-chromen-2-one (53): White solid; 0.02 g; $\delta^1\text{H}$ (500MHz; CDCl_3) 7.95 (dd, 1H, $^3\text{J}_{\text{HH}}$ 10.0, H₄), 7.35 (dt, 1H, $^4\text{J}_{\text{HF}}$ 8.5 $^3\text{J}_{\text{HH}}$ $^3\text{J}_{\text{HF}}$ 9.5, H₇), 7.10 (ddd, 1H, $^3\text{J}_{\text{HH}}$ 9.5 $^4\text{J}_{\text{HF}}$ 3.5 $^5\text{J}_{\text{HF}}$ 2.0, H₈), 6.52 (d, 1H, $^3\text{J}_{\text{HH}}$ 10.0, H₃); $\delta^{19}\text{F}$ (376MHz; CDCl_3) -142.6 (ddd, 1F, $^3\text{J}_{\text{FF}}$ 20.7 $^3\text{J}_{\text{HF}}$ 9.8 $^4\text{J}_{\text{HF}}$ 3.8, F₆), -143.5 (ddd, 1F, $^3\text{J}_{\text{FF}}$ 20.7 $^4\text{J}_{\text{HF}}$ 8.3 $^5\text{J}_{\text{HF}}$ 1.5, F₅); $\delta^{13}\text{C}$ (126 MHz; CDCl_3) 159.4 (s, C₂), 149.7 (s, C_{8a}), 146.2 (dd, $^1\text{J}_{\text{CF}}$ 246.1 $^2\text{J}_{\text{CF}}$ 11.5, C₅), 145.6 (dd, $^1\text{J}_{\text{CF}}$ 257.0 $^2\text{J}_{\text{CF}}$ 14.5, C₆), 135.4 (s, C₄), 120.0 (d, $^2\text{J}_{\text{CF}}$ 20.0, C₇), 117.8 (s, C₃), 112.5 (s, C₈), 110.2 (d, $^2\text{J}_{\text{CF}}$ 16.0, C_{4a}); m/z (EI⁺) 182 (M⁺, 85%), 154 (100), 125 (54); M⁺, 182.017612. C₉H₄F₂O₂ requires M⁺, 182.017936; X-ray crystallography (selected data) Temp. 120(2) K, $\lambda = 0.71073$ Å, Monoclinic, P2₁/c (No. 14), $a = 7.071(1)$ Å, $b = 8.522(6)$ Å, $c = 12.291(1)$ Å, $\alpha = 90^\circ$, $\beta = 105.54(1)^\circ$, $\gamma = 90^\circ$, $V = 713.57(14)$ Å³, Density (calc.) = 1.705 g/cm³, R(int) = 0.0481, Crystal size = 0.25 x 0.20 x 0.08 mm³, R1 = 0.050, wR2 = 0.125.

6,8-Difluoro-2H-chromen-2-one (not isolated) (54): $\delta^{19}\text{F}$ (376MHz; CDCl_3) -124.6 (ddd, 1F, $^4\text{J}_{\text{FF}}$ 17.7 $^3\text{J}_{\text{HF}}$ 8.3 $^3\text{J}_{\text{HF}}$ 4.5, F₆), -138.3 (ddd, 1F, $^4\text{J}_{\text{FF}}$ 17.3 $^3\text{J}_{\text{HF}}$ 12.0 $^5\text{J}_{\text{HF}}$ 2.3, F₈).

3,4-Difluorochroman-2-one (not isolated) (55): $\delta^{19}\text{F}$ (188MHz; CDCl_3) -177.0 (ddd, 1F, $^2\text{J}_{\text{HF}}$ 54.0 $^3\text{J}_{\text{FF}}$ 29.3 $^3\text{J}_{\text{HF}}$ 15.6, F₃), -206.8 (ddd, 1F, $^2\text{J}_{\text{HF}}$ 44.7 $^3\text{J}_{\text{FF}}$ 15.4 $^3\text{J}_{\text{HF}}$ 6.4, F₄).

3-Fluoro-2-oxochroman-4-yl Methanoate (not isolated) (56): $\delta^{19}\text{F}$ (188MHz; CDCl_3) -205.2 (dd, $^2\text{J}_{\text{HF}}$ 45.7 $^3\text{J}_{\text{HF}}$ 5.5, F₃).

8.1.2 Direct fluorination of 6-methyl-2H-chromen-2-one (57)

Experiment 1: 6-Methyl-2H-chromen-2-one (2.5 g, 17 mmol) and fluorine (78 mmol, 5 equiv.). Gave a yellow solid 2.70 g. Conversion determined to be 45%; of which, 78% yield of 5-fluoro-6-methyl-2H-chromen-2-one and an 8% yield of 6-fluoro-6-methyl-6-hydro-2H-chromene-2,5-dione.

Experiment 2: 6-Methyl-2H-chromen-2-one (2.5 g, 17 mmol) and fluorine (78 mmol, 5 equiv.). Gave a yellow solid 9.76g (in DCM). Conversion determined to be 46%; of which, 77% yield of 5-fluoro-6-methyl-2H-chromen-2-one and a 9% yield of 6-fluoro-6-methyl-6-hydro-2H-chromene-2,5-dione.

Experiment 3: 6-Methyl-2H-chromen-2-one (5.0 g, 34 mmol) and fluorine (170 mmol, 5 equiv.) dissolved in sulfuric acid (> 98%) (90 ml) and water (10ml). Gave a yellow oil 15.45g (in DCM). Conversion determined to be 52%; of which, 69% yield of 5-fluoro-6-methyl-2H-chromen-2-one and a 10% yield of 6-fluoro-6-methyl-6-hydro-2H-chromene-2,5-dione.

Purification of 5-fluoro-6-methyl-2H-chromen-2-one was achieved by using chromatography on silica, using diethyl ether/ hexane (1:1 ratio) as elutant; crystals suitable for x-ray analysis were obtained by the slow evaporation of ethanol/ water (1:1 ratio). Purification of 6-fluoro-6-methyl-6-hydro-2H-chromene-2,5-dione was achieved by using chromatography on silica, using diethyl ether/ hexane (1:1 ratio) as elutant, subsequently followed by using chromatography on silica, diethyl ether/ hexane (3:7 ratio) as elutant; crystals suitable for x-ray analysis were obtained by the slow evaporation of diethyl ether/ hexane (3:7 ratio).

5-Fluoro-6-methyl-2H-chromen-2-one (58): White solid; 0.52g; m.p. 78-79°C; $\delta^1\text{H}$ (400MHz; CDCl_3) 7.93 (d, 1H, $^3\text{J}_{\text{HH}}$ 9.6, H₄), 7.32 (t, 1H, $^3\text{J}_{\text{HH}}$ $^4\text{J}_{\text{HF}}$ 8.4, H₇), 7.02 (d, 1H, $^3\text{J}_{\text{HH}}$ 8.8, H₈), 6.42 (d, 1H, $^3\text{J}_{\text{HH}}$ 9.6, H₃), 2.30 (d, 3H, $^4\text{J}_{\text{HF}}$ 2.0, Me); $\delta^{19}\text{F}$ (376MHz; CDCl_3) -123.8 (d, $^4\text{J}_{\text{HF}}$ 8.3, F₅); $\delta^{13}\text{C}$ (100MHz; CDCl_3) 160.1 (s, C₂), 156.2 (d, $^1\text{J}_{\text{CF}}$ 251.6, C₅), 152.6 (d, $^3\text{J}_{\text{CF}}$ 4.6, C_{8a}), 136.4 (d, $^3\text{J}_{\text{CF}}$ 4.6, C₄), 134.0 (d, $^3\text{J}_{\text{CF}}$ 6.8, C₇), 119.7 (d, $^2\text{J}_{\text{CF}}$ 16.0, C_{4a}), 116.5 (d, $^4\text{J}_{\text{CF}}$ 1.9, C₃), 112.0 (d, $^4\text{J}_{\text{CF}}$ 4.2, C₈), 108.6 (d, $^2\text{J}_{\text{CF}}$ 19.8, C₆), 13.8 (d, $^3\text{J}_{\text{CF}}$ 3.5, Me); ν_{max} (KBr disc)/ cm^{-1} 3059, 1744, 1637, 1611, 1578; m/z (EI⁺) 178 (M⁺, 82%), 150 (63), 149 (90); M⁺, 178.042877. C₁₀H₇FO₂ requires M⁺, 178.043008; X-ray crystallography (selected data) Temp. 120.0(2) K, $\lambda = 0.71073 \text{ \AA}$, Orthorhombic, Pna2₁, a = 20.0846(5) \AA , b = 3.7945(1) \AA , c = 10.4322(4) \AA , $\alpha = 90^\circ$, $\beta = 90^\circ$, $\gamma = 90^\circ$, V = 795.05(4) \AA^3 , Density (calc.) = 1.488 g/cm³, R(int) = 0.0220, Crystal size = 0.40 x 0.18 x 0.18 mm³, R1 = 0.031, wR2 = 0.088.

6-Fluoro-6-methyl-6-hydro-2H-chromene-2,5-dione (59): Yellow solid; 0.16g; m.p. 128-130°C; $\delta^1\text{H}$ (400MHz; CDCl_3) 7.76 (d, 1H, $^3\text{J}_{\text{HH}}$ 9.6, H₄), 6.70 (dd, 1H, $^3\text{J}_{\text{HH}}$ 10.4

$^3J_{\text{HF}}$ 7.6, H₇), 6.42 (d, 1H, $^3J_{\text{HH}}$ 10.4, H₈), 6.23 (d, 1H, $^3J_{\text{HH}}$ 9.6, H₃), 1.57 (d, 3H, $^3J_{\text{HF}}$ 22.0, Me); $\delta^{19}\text{F}$ (376MHz; CDCl_3) -158.6 (qd, $^3J_{\text{HF}}$ 22.8 $^3J_{\text{HF}}$ 7.5, F₆); $\delta^{13}\text{C}$ (100MHz; CDCl_3) 191.9 (d, $^2J_{\text{CF}}$ 16.4, C₅), 165.2 (d, $^4J_{\text{CF}}$ 3.4, C_{8a}), 158.6 (s, C₂), 143.7 (d, $^2J_{\text{CF}}$ 23.3, C₇), 138.9 (s, C₄), 120.6 (d, $^3J_{\text{CF}}$ 8.8, C₈), 114.4 (s, C₃), 110.0 (d, $^3J_{\text{CF}}$ 4.2, C_{4a}), 90.4 (d, $^1J_{\text{CF}}$ 180.3, C₆), 24.2 (d, $^2J_{\text{CF}}$ 26.6, Me); ν_{max} (KBr disc)/ cm^{-1} 3091, 3059, 3022, 2995, 2939, 1756, 1736, 1689, 1602, 1545; m/z (EI⁺) 194 (M⁺, 82%), 100 (100); M⁺, 194.038471. C₁₀H₇FO₃ requires M⁺, 194.037922; X-ray crystallography (selected data) Temp. 120.0(2) K, $\lambda = 0.71073 \text{ \AA}$, Monoclinic, P2₁/c, a = 9.4545(3) \AA , b = 10.7328(4) \AA , c = 8.2003(3) \AA , $\alpha = 90^\circ$, $\beta = 94.737(2)^\circ$, $\gamma = 90^\circ$, V = 829.27(5) \AA^3 , Density (calc.) = 1.555 g/cm^3 , R(int) = 0.0168, Crystal size = 0.35 x 0.26 x 0.22 mm^3 , R1 = 0.037, wR2 = 0.106.

Attempted displacement of fluorine in 5-fluoro-6-methyl-2H-chromen-2-one (58)

5-Fluoro-6-methyl-2H-chromen-2-one (50 mg, 0.28 mol) was weighed into a NMR tube. To this was added absolute ethanol (0.5ml) and concentrated sulfuric acid (>98%) (0.5 ml). A known amount of trifluoromethylbenzene was also weighed into the NMR tube and the ^{19}F NMR was taken. Thereafter, ^{19}F NMRs were taken regularly for a period of four days. In between, the NMR tube was agitated at a rate of 10 revolutions min^{-1} . After four days no change in the ^{19}F NMR integrals was observed.

8.1.3 Direct fluorination of 7-methoxy-2H-chromen-2-one (60)

Experiment 1: 7-Methoxy-2H-chromen-2-one (2.5 g, 14 mmol) and fluorine (70 mmol, 5 equiv.). Gave a yellow solid 2.48 g. Conversion determined to be 55%; of which, 70% yield of 8-fluoro-7-methoxy-2H-chromen-2-one and 20% yield of 8,8-difluoro-8-hydro-2H-chromene-2,7-dione.

Experiment 2: 7-Methoxy-2H-chromen-2-one (4.1 g, 23 mmol) and fluorine (234 mmol, 10 equiv.). Extracted with several portions of dichloromethane and separately, several portions of ethyl ethanoate. Gave a yellow solid 4.64 g. Homogenised to 102.54 g in ethyl ethanoate.

Conversion determined to be 75%; of which, 75% yield of 8,8-difluoro-8-hydro-2H-chromene-2,7-dione.

Experiment 3: 7-Methoxy-2H-chromen-2-one (2.5 g, 14 mmol) and fluorine (70 mmol, 5 equiv.). Extracted with several portions of dichloromethane and separately, several portions of ethyl ethanoate. Gave a yellow solid 3.53 g. Homogenised to 85.53 g in acetonitrile.

Conversion determined to be 65%; of which, 66% yield of 8-fluoro-7-methoxy-2H-chromen-2-one and 23% yield of 8,8-difluoro-8-hydro-2H-chromene-2,7-dione.

Experiment 4: 7-Methoxy-2H-chromen-2-one (4.1 g, 23 mmol) and fluorine (234 mmol, 10 equiv.). Extracted with several portions of dichloromethane and separately, several portions of ethyl ethanoate. Gave a yellow solid 3.97 g. Conversion determined to be 78%; of which, 75% yield of 8,8-difluoro-8-hydro-2H-chromene-2,7-dione.

Experiment 5: 7-Methoxy-2H-chromen-2-one (4.1 g, 23 mmol) and fluorine (234 mmol, 10 equiv.). Extracted with several portions of dichloromethane and separately, several portions of ethyl ethanoate. Gave a yellow solid 4.70 g. Conversion determined to be 94%; of which, 72% yield of 8,8-difluoro-8-hydro-2H-chromene-2,7-dione.

Work-up did not involve neutralisation. Purification of 8-fluoro-7-methoxy-2H-chromen-2-one was achieved by recrystallisation from acetonitrile; crystals suitable for x-ray analysis were obtained by the slow evaporation of acetonitrile. The purification of 8,8-difluoro-8-hydro-2H-chromene-2,7-dione was achieved by crystallisation from dichloromethane; crystals suitable for x-ray analysis were obtained in a similar manner. An enriched sample of 6,8-difluoro-7-methoxy-2H-chromen-2-one was obtained from run 4 by repeatedly washing the sample with saturated sodium hydrogen carbonate solution.

8-Fluoro-7-methoxy-2H-chromen-2-one (61): White solid; 0.16 g; m.p. 190-192 °C; $\delta^1\text{H}$ (500MHz; DMSO- d_6 ; 50°C) 7.97 (d, 1H, $^3J_{\text{HH}}$ 9.5, H₄), 7.46 (d, 1H, $^3J_{\text{HH}}$ 8.5, H₅), 7.17 (t, 1H, $^3J_{\text{HH}}$ $^4J_{\text{HF}}$ 8.0, H₆), 6.32 (d, 1H, $^3J_{\text{HH}}$ 9.5, H₃), 3.94 (s, 3H, OMe); $\delta^{19}\text{F}$ (470MHz; DMSO- d_6 ; 50°C) -158.0 (d, $^4J_{\text{HF}}$ 8.0, F₈); $\delta^{13}\text{C}$ (126MHz; DMSO- d_6 ; 50°C) 158.6 (s, C₂), 149.8 (d, $^2J_{\text{CF}}$ 7.4, C_{8a}), 144.0 (s, C₄), 143.7 (s, C_{4a}), 142.3 (d, $^2J_{\text{CF}}$ 8.6, C₇), 138.2 (d, $^1J_{\text{CF}}$ 247.6, C₈), 123.4 (s, C₅), 113.2 (s, C₃), 109.5 (s, C₆), 56.6 (s, OMe); ν_{max} (KBr disc)/ cm^{-1} 3084, 3027, 2987, 2842, 1719, 1628, 1568, 1508; m/z (EI⁺) 194 (M⁺, 82%), 166 (61), 151 (100); M⁺, 194.038008. C₁₀H₇FO₃ requires M⁺, 194.037922; X-ray crystallography (selected data) Temp. 150(2) K, $\lambda = 0.71073 \text{ \AA}$, Orthorhombic, Pna2₁

(No. 33), $a = 6.9083(12) \text{ \AA}$, $b = 18.576(2) \text{ \AA}$, $c = 6.5029(12) \text{ \AA}$, $\alpha = 90^\circ$, $\beta = 90^\circ$, $\gamma = 90^\circ$, $V = 834.5(2) \text{ \AA}^3$, Density (calc.) = 1.545 g/cm^3 , $R(\text{int}) = 0.0435$, Crystal size = $0.53 \times 0.17 \times 0.01 \text{ mm}^3$, $R1 = 0.041$, $wR2 = 0.107$.

6,8-Difluoro-7-methoxy-2H-chromen-2-one (not isolated) (62): $\delta^1\text{H}$ (400MHz; CDCl_3) 7.59 (dd, 1H, $^3J_{\text{HH}} 10.0$ $^4J_{\text{HH}} 1.6$, H_4), 7.01 (dd, 1H, $^3J_{\text{HF}} 10.0$ $^4J_{\text{HH}} 2.0$, H_5), 6.40 (d, 1H, $^3J_{\text{HH}} 9.6$, H_3), 4.13 (dd, 3H, $^5J_{\text{HF}} 1.6$ $^5J_{\text{HF}} 1.2$, OMe); $\delta^{19}\text{F}$ (376 MHz; CDCl_3) -133.0 (m, 1F, F_6), -148.3 (m, 1F, F_8).

8,8-Difluoro-8-hydro-2H-chromene-2,7-dione (63): Yellow solid; 0.3 g; m.p. 133-135°C; $\delta^1\text{H}$ (400MHz; CDCl_3) 7.37 (dm, 1H, $^3J_{\text{HH}} 9.6$, H_4), 7.21 (d, 1H, $^3J_{\text{HH}} 10.4$, H_5), 6.55 (dm, 1H, $^3J_{\text{HH}} 10.0$, H_3), 6.25 (dm, 1H, $^3J_{\text{HH}} 10.0$, H_6); $\delta^{19}\text{F}$ (376MHz; CDCl_3) -112.3 (s, 2F, $\text{F}_{8\alpha}$); $\delta^{13}\text{C}$ (100MHz; CDCl_3) 184.4 (t, $^2J_{\text{CF}} 22.5$, C_7), 157.3 (s, C_2), 152.1 (t, $^2J_{\text{CF}} 22.5$, $\text{C}_{8\alpha}$), 141.5 (s, C_4), 140.0 (s, C_5), 122.1 (t, $^3J_{\text{CF}} 3.4$, C_6), 119.9 (s, C_3), 112.7 (t, $^3J_{\text{CF}} 6.5$, $\text{C}_{4\alpha}$), 100.1 (d, $^1J_{\text{CF}} 248.2$, C_8); m/z (EI^+) 198 (M^+ , 21%), 63 (100); ν_{max} (KBr disc)/ cm^{-1} 3066, 1753, 1698, 1589; M^+ , 198.012302. $\text{C}_9\text{H}_4\text{F}_2\text{O}_3$ requires M^+ , 198.012851; X-ray crystallography (selected data) Temp. 293(2) K, $\lambda = 0.71073 \text{ \AA}$, Monoclinic, $\text{P2}_1/\text{m}$ (No.), $a = 7.020(1) \text{ \AA}$, $b = 6.503(1) \text{ \AA}$, $c = 8.748(1) \text{ \AA}$, $\alpha = 90^\circ$, $\beta = 96.73(1)^\circ$, $\gamma = 90^\circ$, $V = 396.60(9) \text{ \AA}^3$, Density (calc.) = 1.659 g/cm^3 , $R(\text{int}) = 0.0261$, Crystal size = $0.55 \times 0.25 \times 0.09 \text{ mm}^3$, $R1 = 0.046$, $wR2 = 0.151$.

6,8,8-Triifluoro-8-hydro-2H-chromene-2,7-dione (not isolated) (64): $\delta^{19}\text{F}$ (188MHz; CDCl_3) -111.2 (d, 2F, $^4J_{\text{FF}} 8.1$ $\text{F}_{8\alpha}$), -133.1 (q, 1F, $^3J_{\text{HF}}$ $^4J_{\text{FF}} 8.3$, F_6).

8.1.4 Direct fluorination of 7-ethoxy-4-methyl-2H-chromen-2-one (65)

Experiment 1: 7-Ethoxy-4-methyl-2H-chromen-2-one (3.3 g, 16 mmol) and fluorine (40 mmol, 5 equiv.). Gave a yellow solid 2.7 g. Homogenised to 31.83g in dichloromethane. Conversion determined to be 60%; of which, 66% yield of 8-fluoro-7-ethoxy-4-methyl-2H-chromen-2-one and 12% yield of 8,8-difluoro-4-methyl-8-hydro-2H-chromene-2,7-dione.

Experiment 2: 7-Ethoxy-4-methyl-2H-chromen-2-one (3.3 g, 16 mmol) and fluorine (80 mmol, 5 equiv.). Gave a yellow solid 2.8 g. Homogenised to 39.40g in dichloromethane. Conversion determined to be 76%; of which, 55% yield of 8-fluoro-7-

ethoxy-4-methyl-2H-chromen-2-one and 26% yield of 8,8-difluoro-4-methyl-8-hydro-2H-chromene-2,7-dione.

Experiment 3: 7-Ethoxy-4-methyl-2H-chromen-2-one (6.6 g, 32 mmol) and fluorine (320 mmol, 10 equiv.). Gave a yellow solid 6.2 g. Homogenised to 114.11g in dichloromethane. Conversion determined to be 68%; of which, 80% yield of 8,8-difluoro-4-methyl-8-hydro-2H-chromene-2,7-dione.

Work-up did not involve neutralisation. Purification of 7-ethoxy-8-fluoro-4-methyl-2H-chromen-2-one was achieved by washing the crude product with diethyl ether; the insoluble material was further purified by chromatography on silica, using dichloromethane as elutant; crystals suitable for x-ray analysis were obtained by the slow evaporation of dichloromethane. Purification of 8,8-difluoro-4-methyl-8-hydro-2H-chromene-2,7-dione was achieved by dissolving the crude reaction mixture in minimum hot dichloromethane, subsequently followed by the addition of cold hexane, product was removed by filtration; this procedure was repeated several times.

7-Ethoxy-8-fluoro-4-methyl-2H-chromen-2-one (66): White solid; 0.15g; m.p. 149-151°C; $\delta^1\text{H}$ (500MHz; CDCl_3) 7.22 (d, 1H, $^3\text{J}_{\text{HH}}$ 8.5, H₆), 6.83 (m, 1H, H₅), 6.08 (s, 1H, H₃), 4.13 (q, 2H, $^3\text{J}_{\text{HH}}$ 7.0, OCH_2CH_3), 2.33 (s, 3H, 4-Me), 1.42 (t, 3H, $^3\text{J}_{\text{HH}}$ 7.0, CH_2CH_3); $\delta^{19}\text{F}$ (376MHz; CDCl_3) -155.7 (d, $^4\text{J}_{\text{HF}}$ 6.8, F₈); $\delta^{13}\text{C}$ (126MHz; CDCl_3) 159.7 (s, C₂), 152.3 (d, $^3\text{J}_{\text{CF}}$ 2.4, C_{4a}), 149.6 (d, $^2\text{J}_{\text{CF}}$ 7.7, C₇), 142.9 (d, $^2\text{J}_{\text{CF}}$ 9.2, C_{8a}), 139.7 (d, $^1\text{J}_{\text{CF}}$ 251.0, C₈), 119.2 (d, $^3\text{J}_{\text{CF}}$ 4.8, C₆), 114.6 (s, C₄), 112.6 (s, C₃), 109.6 (s, C₅), 65.5 (s, OCH_2CH_3), 18.7 (s, 4-Me), 14.7 (s, CH_2CH_3); ν_{max} (KBr disc)/ cm^{-1} 3071, 2979, 2899, 2871, 1738, 1628, 1570, 1519; m/z (EI⁺) 222 (M⁺, 52%), 194 (52), 166 (100); found C, 64.59; H, 4.99. C₁₂H₁₁FO₃ requires C, 64.86; H, 4.99; N, 5.85%; X-ray crystallography (selected data) Temp. 120(2) K, $\lambda = 0.71073 \text{ \AA}$, Monoclinic, P2₁/n, a = 4.8635(5) \AA , b = 18.235(2) \AA , c = 11.854(1) \AA , $\alpha = 90^\circ$, $\beta = 92.82(3)^\circ$, $\gamma = 90^\circ$, V = 1050.0(2) \AA^3 , Density (calc.) = 1.406 g/cm^3 , R(int) = 0.0327, Crystal size = 0.80 x 0.14 x 0.04 mm^3 , R1 = 0.046, wR2 = 0.123.

7-Ethoxy-6,8-difluoro-4-methyl-2H-chromen-2-one (not isolated) (67): $\delta^{19}\text{F}$ (376 MHz; CDCl_3) -132.3 (m, 1F, F₆), -147.4 (d, 1F, $^4\text{J}_{\text{FF}}$ 5.3, F₈).

8,8-Difluoro-4-methyl-8-hydro-2H-chromene-2,7-dione (68): Yellow solid; 1.06g; m.p. 138-140°C; $\delta^1\text{H}$ (500MHz; DMSO-d_6) 7.75 (d, 1H, $^3\text{J}_{\text{HH}}$ 10.5, H₅), 6.58 (s, 1H, H₃),

6.36 (d, 1H, $^3J_{\text{HH}}$ 10.5, H₆), 2.35 (s, 3H, Me); $\delta^{19}\text{F}$ (376MHz; DMSO-d₆) -111.6 (s, 2F, F₈); $\delta^{13}\text{C}$ (126MHz; DMSO-d₆) 185.6 (t, $^2J_{\text{CF}}$ 22.2, C₇), 158.7 (s, C₂), 154.8 (s, C₄), 151.2 (t, $^2J_{\text{CF}}$ 21.5, C_{8a}), 140.9 (s, C₅), 121.6 (t, $^3J_{\text{CF}}$ 2.8, C₆), 117.0 (s, C₃), 115.1 (t, $^3J_{\text{CF}}$ 6.7, C_{4a}), 101.6 (t, $^1J_{\text{CF}}$ 247.2, C₈), 19.5 (s, Me); ν_{max} (KBr disc)/cm⁻¹ 3072, 1747, 1693, 1592; m/z (EI⁺) 212 (M⁺, 100%), 184 (82), 128 (67); [M-NH₄]⁺, 230.0630. C₁₀H₁₀F₂NO₂ requires [M-NH₄]⁺, 230.0629.

6,8,8-Trifluoro-4-methyl-8-hydro-2H-chromene-2,7-dione (not isolated) (69): $\delta^{19}\text{F}$ (376MHz; DMSO-d₆) -110.0 (d, 2F, $^4J_{\text{FF}}$ 9.0 F₈), -135.6 (m, 1F, F₆).

Chapter 9.0: Experimental Section to Chapter 5.0

9.1 Fabrication of the Microreactors

Stainless steel was supplied from R.G.B. Stainless Ltd, polytrifluorochloroethylene was supplied by Fluorocarbon. Polytetrafluoroethylene, nickel, copper, and lead sheet were obtained from Goodfellows, fittings were obtained from Swagelok[®]; screws and washers were obtained from RS. Electric discharge machining was performed by Dow Tooling, while stainless steel chemical etching was performed by Photofabrication Ltd. Laser machining of stainless steel sheet was performed by Hydram Engineering and Micrometric Techniques Ltd.

9.1.1 Fabrication of the Three-Channel Microreactor (V-19) and Accompanying Apparatus

A nickel sheet 52mm by 96mm by 6mm (width x length x height) was acquired from a commercial supplier. Using a milling machine possessing a slitting saw attachment, three parallel 0.5mm by 0.5mm by 73mm channel slots were cut into the nickel sheet, as depicted in figure 9.1. Screw holes of 3mm diameter are drilled into the nickel sheet using a milling machine, at positions as shown in figure 9.2. At each screw hole position on the reverse side of the sheet to the channel slots, is machined a conical indent which matches the head size of the screw. This allows the head of the screw to be accommodated within the nickel block, hence providing a planar lower surface. Cooling channels of 2.5mm diameter are then drilled through the nickel sheet, down the middle of the width axis. Both ends of the cooling channels are enlarged to 3mm in diameter by 5mm deep to allow the attachment of the copper cooling tubes, as shown in figure 9.3. A 3mm diameter by 10mm deep hole was drilled at one end of the block, so that a thermocouple probe could be inserted. The channel side of the sheet is subsequently polished using silicon carbide/ water paste on a glass surface, in a figure of eight movement until the surface is uniform. Copper cooling tubes are then attached to the cooling channel holes by silver soldering.

A 6mm thick polytrifluorochloroethylene (PTFCE) sealing plate is cut to the same size as the nickel sheet, and screw holes are fabricated into analogous positions as described above. Likewise, a 2mm stainless steel sheet is fabricated to the same

specifications as the PTFCE sheet, however three parallel 5mm wide viewing slots are fabricated by milling, into the stainless steel, so the channel slots are centred in the middle of the viewing slot as depicted in figure 9.4.

Finally, 1.5mm diameter holes are machined through the PTFCE to allow the insertion of 1.5mm nickel tubes, namely the liquid inlet, the fluorine inlet, and the product outlet tubes. The separate components are attached together using twenty-eight 3mm nickel-plated brass screws, washers and nuts, as shown in figure 9.5. A torque wrench was used to ensure that equal pressure was applied to each screw. Swagelok[®] fittings were added to the various tubes so that the microreactor can be attached to the fluorination gas handling apparatus. The outlet tubes were fabricated from 1.5mm diameter nickel and PTFCE tubing and have a total length of 250mm.

Prior to use, the reactor was leak tested and passivated using 10%, 20%, and 50% F₂/N₂ mixtures. When the microreactor is in use, it is positioned in a horizontal orientation.

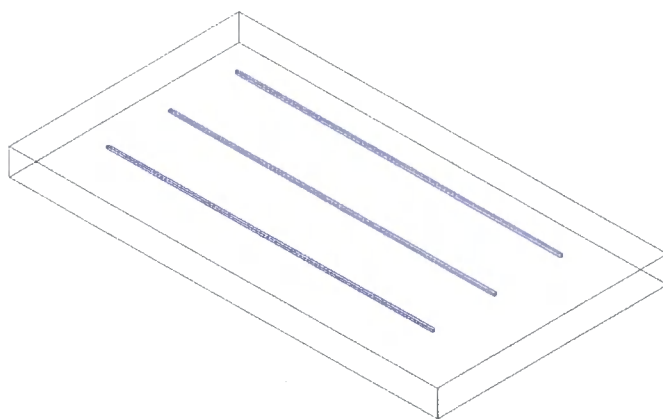

Fig 9.1. Nickel sheet and three channel slots

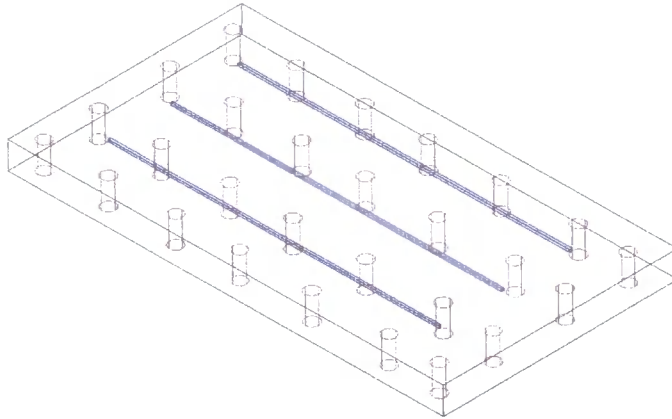

Fig 9.2: Depicts the addition of twenty-eight screw holes

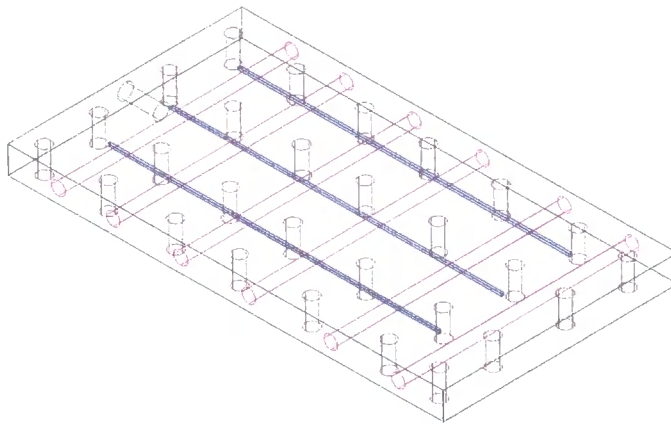

Fig 9.3: Diagram showing the addition of cooling channels

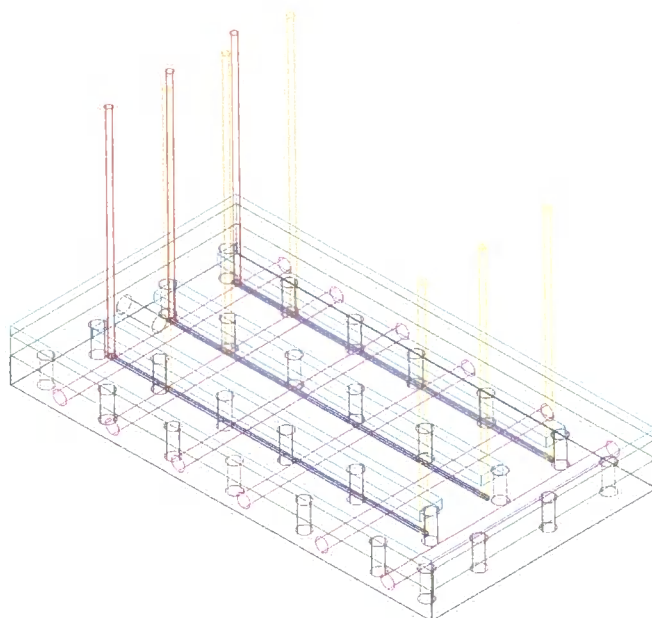

Fig 9.4: Depicts the addition of PTFCE sheet and stainless steel (in green) sheet with channel viewing slots (in blue). Nickel liquid inlet (in red), gas inlet (in orange), and product outlet tubes (in yellow) are also shown

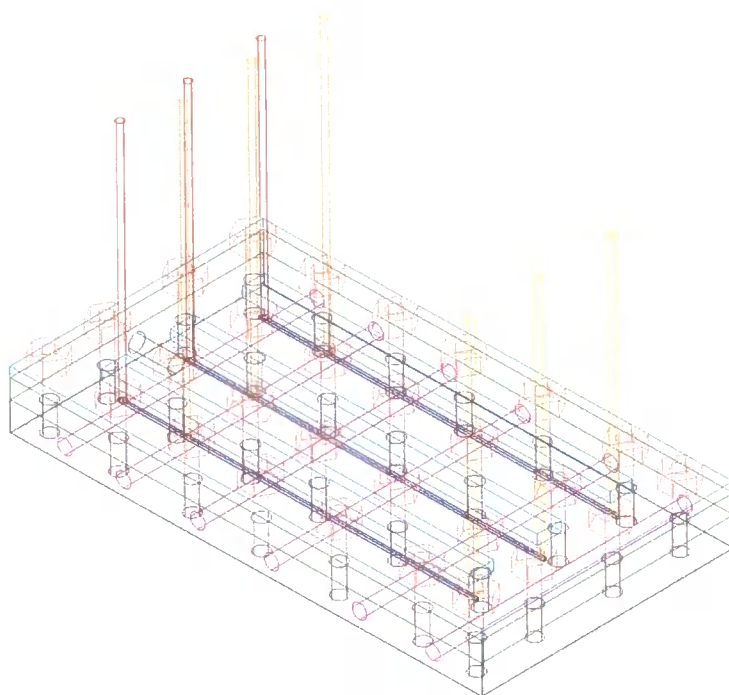

Fig 9.5: Final assembly of triple-channel microreactor (N.B. External cooling tubes are not shown for clarity.)

The gas/ liquid reservoirs were fabricated from stainless steel tube and sheet, as shown in figure 9.6. The liquid reservoir was fabricated from a 10mm length of 20mm diameter tube. At one side of the tube section was welded a 20mm diameter by 2mm thick circle possessing in the middle, a single 3mm diameter inlet tube; while at the other side was welded a 20mm diameter by 2mm thick circle possessing three 3mm diameter outlet tubes, located at $\sim 120^\circ$ from each other. The gas reservoir was fabricated in a similar manner, however a 15mm length of 50mm diameter stainless steel tube was used and the inlet tube is 6mm in diameter. Both reservoirs are shown in figures 9.7 and 9.8.

The nozzle cleaning device was fabricated from a polytetrafluoroethylene T-piece fitting, as shown in figures 9.9 and 9.10. The three 1.5mm diameter nickel outlet tubes pass through a 4mm thick PTFE stopper, located at the top of the T-piece. These outlet tubes pass through the T-piece and out of the opposite opening for a further 50mm. Through the centre of the PTFE middle section opposite the waste gas outlet orifice was

drilled a 3mm diameter hole, through which a 3mm diameter PTFCE tube was inserted. The end of the tube is located 10mm above the end of the nickel outlet tubes.

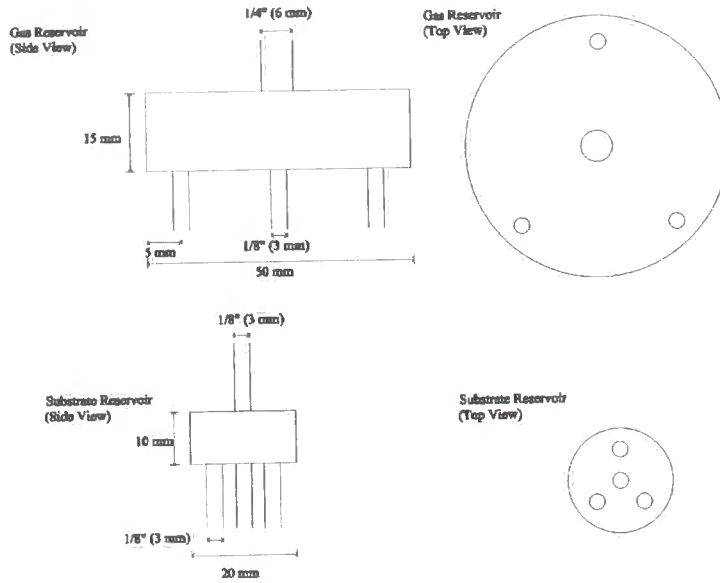
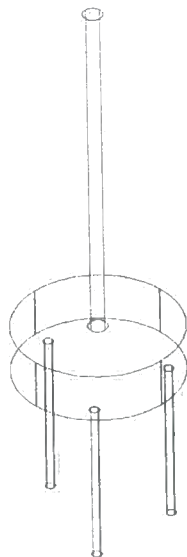
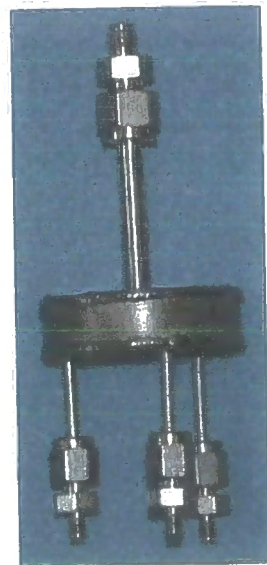

Fig 9.6: Dimensions of the gas and liquid reservoirs



(a)



(b)

Fig 9.7: (a) Three-Dimensional wire frame diagram of the gas reservoir; (b) Photograph of the gas reservoir

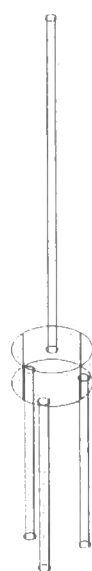

(a)



(b)

Fig 9.8: (a) Three-dimensional wire frame diagram of the liquid reservoir;
(b) Photograph of the liquid reservoir

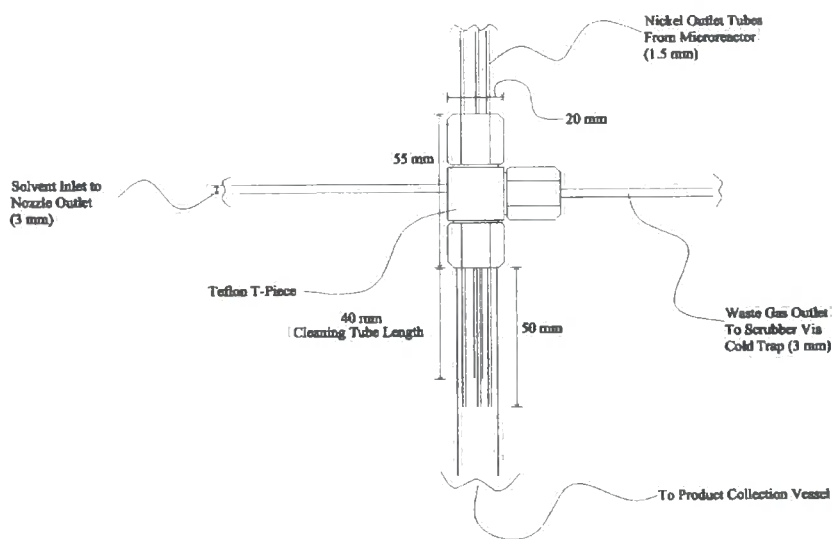

Fig 9.9: Diagram of the nozzle cleaning device

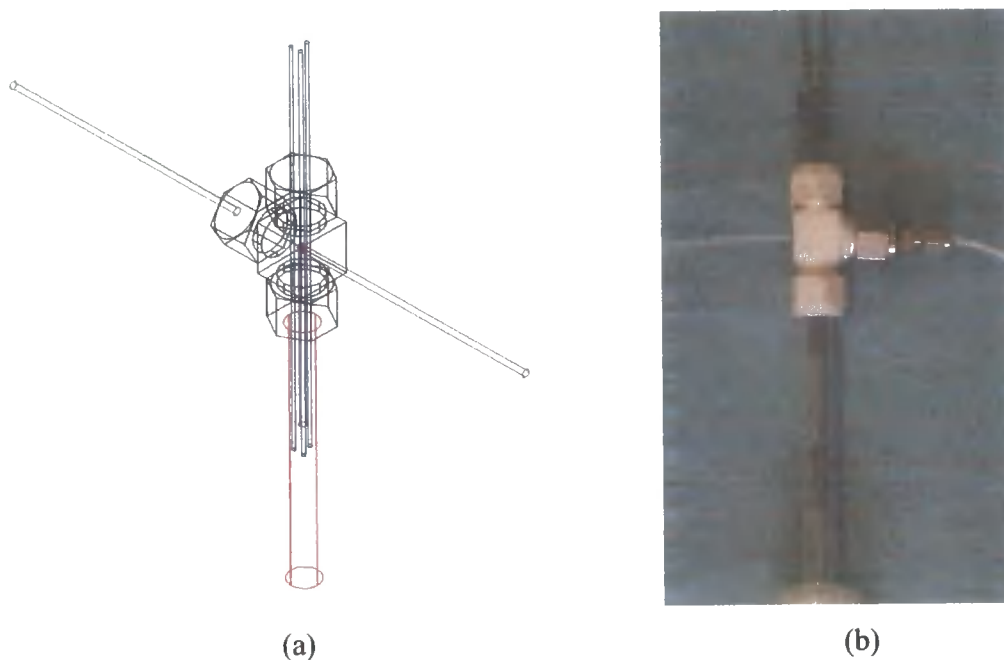

Fig.9.10: (a) Depicts nickel tubes (in blue), T-piece (in black), waste gas tube (in green), solvent wash tube (in purple), and product collection vessel (in red); (b) Photograph of the Nozzle cleaning device

9.1.2 Fabrication of the Twelve-Channel Microreactor (V-20)

A block of stainless steel (321 grade) measuring by 61mm by 170mm by 31mm was fabricated by milling, from a larger block of stainless steel (See Figs 9.11 and 9.12a). A 20mm diameter gas reservoir, a 20mm diameter liquid reservoir, and a 10mm diameter product collection reservoir were drilled into the stainless steel block. Perpendicular to the gas and product collection reservoirs, was drilled in both cases a 6mm diameter tapped hole, so as to provide entry and exit openings to these reservoirs. A further forty 3mm holes were drilled through the block for screws. Channels measuring 0.5mm by 0.5mm were cut into the surface of the stainless steel block using wire EDM; six channels per-side were machined. The channels were closed at either end by spot welding, and were linked to the reservoirs of 0.5mm diameter holes drilled by EDM drilling.

Hashed Lines Indicate Position Of The Lower
Coolant Tubes Which Are In A Different Position
Compared To The Ones Above

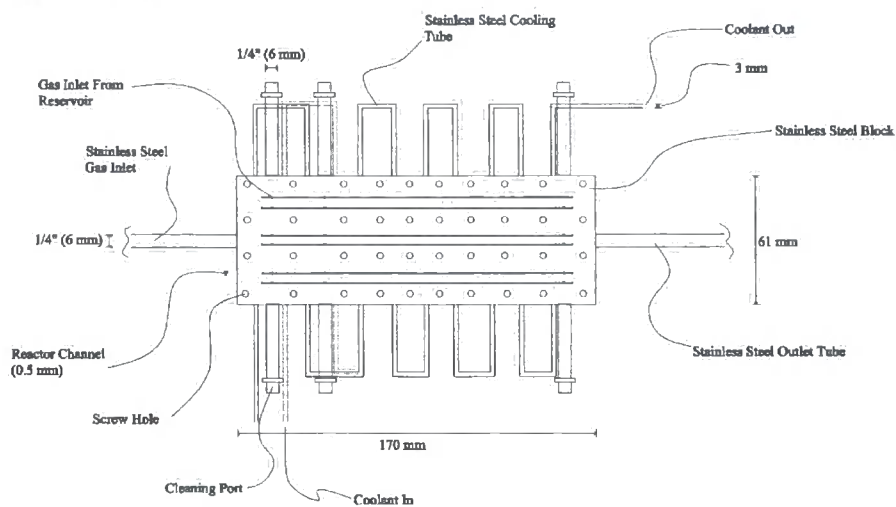
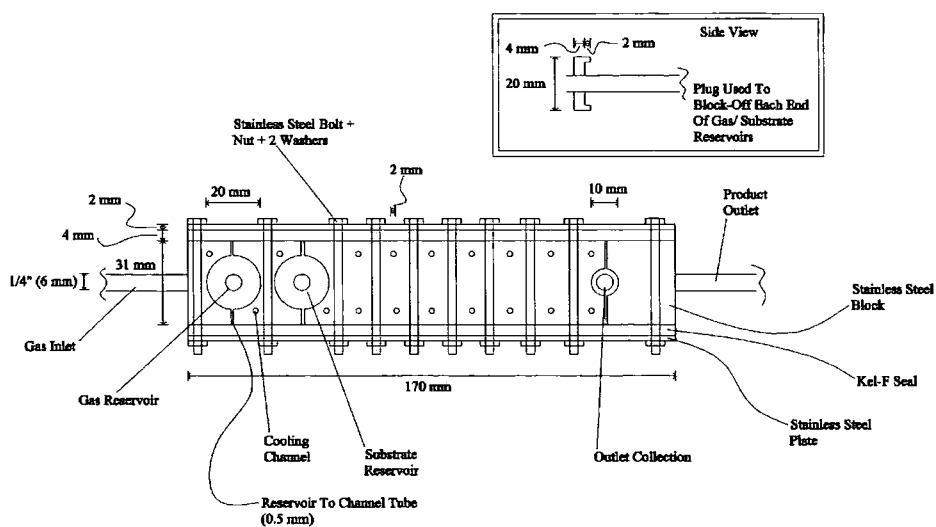

Fig 9.11: Top view of the V-20 microreactor



(a)

Plug Used To Block-Off Each End Of Gas/ Substrate Reservoirs

Side View

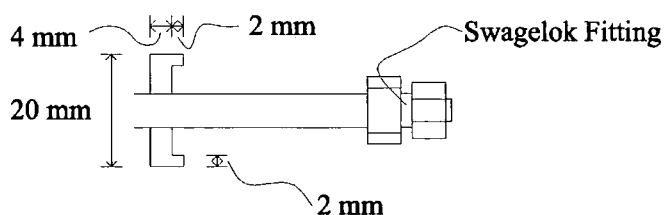

(b)

Fig 9.12: (a) Side view of the V-20 microreactor; (b) Expanded view of the V-20 reservoir plugs

Cooling channels of 2.5mm diameter are then drilled through the stainless steel block. Both ends of the cooling channel holes are enlarged to 3mm in diameter by 5mm deep to allow the attachment of the stainless steel cooling tubes. A 3mm diameter by 20mm deep hole was drilled at one side of the block, so that a thermocouple probe could be inserted. Both sides of the block were subsequently polished using silicon carbide/water paste on a glass surface, in a figure of eight movement until the surface was uniform. Stainless steel cooling tubes were then attached to the cooling channel holes by silver soldering. Access ports for the reservoirs were welded to the block and these were

fabricated from machined stainless steel plugs, 6mm diameter stainless steel tubing, and stainless steel Swagelok[®] unions, as shown in figure 9.12b. Screws were fabricated from 3mm diameter threaded bar, which was cut into forty 50mm lengths. A stainless steel washer and nut per screw were then attached to one end of the threaded bar by spot welding. A torque wrench was used to ensure that equal pressure was applied to each screw.

The sealing plates were fabricated from 6mm thick PTFCE sheet, while the cover plates were fabricated from 2mm thick stainless steel sheet. Viewing slots were machined into the cover plates by the use of a milling machine. To allow the apparatus to be used in a vertical position, a stand was fabricated from 10mm thick stainless steel bar, which was subsequently welded together, and this is shown in figure 9.13.

Prior to use, the reactor was leak tested and passivated using 10%, 20%, and 50% F₂/N₂ mixtures.

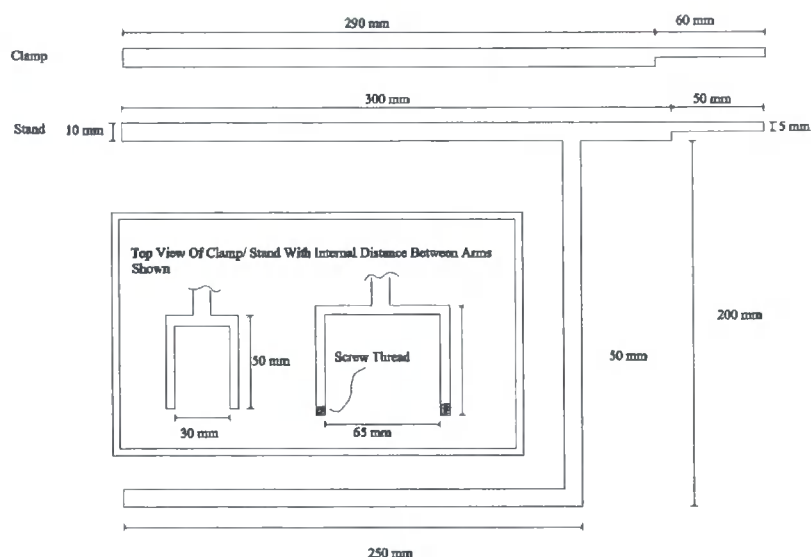

Fig 9.13: Depicts the V-20 microreactor stand

9.1.3 Fabrication of the Multi-Channel Microreactor (V-21)

A block of stainless steel (321 grade) measuring 96mm by 250mm by 50mm was machined from a larger block of stainless steel. A 40mm diameter gas reservoir, a 30mm diameter liquid reservoir, and a 20mm diameter product collection reservoir were drilled

through the stainless steel block. A further five 20mm diameter holes were drilled into the block to allow the block to be supported when in use, as shown in figures 9.14 to 9.16. The block surface and reservoirs were joined together by slots machined by wire EDM, as shown in figure 9.17. These slots in the gas and product collection reservoirs are located in the centre of the reservoir, while the slot in the liquid reservoir is located to the extreme left hand side of the reservoir as drawn horizontally, to prevent the formation of gas pockets. Perpendicular to the gas reservoir and product collection reservoir was drilled in both cases a 6mm diameter tapped hole, so as to provide entry and exit openings to these reservoirs. Cooling channel holes are then drilled through the block, both ends of which were enlarged to 3mm by 5mm deep to allow for the stainless steel cooling channel tubes to be attached, as shown in figure 9.18. Screw holes of 4mm diameter by 5mm deep are drilled into the block, which are then subsequently tapped with an appropriate thread, as depicted in figure 9.19. Tapped stainless steel plugs were then welded into the gas and liquid reservoirs so that the Swagelok[®] fittings could be inserted. The stainless steel cooling tubes were silver soldered into position, and finally, the necessary Swagelok[®] fittings are added to all of the reservoir openings. PTFE O-rings were used in between the block and Swagelok[®] reservoir fittings to ensure that the reservoirs are sealed and to prevent the fitting from partially blocking the reservoir slots.

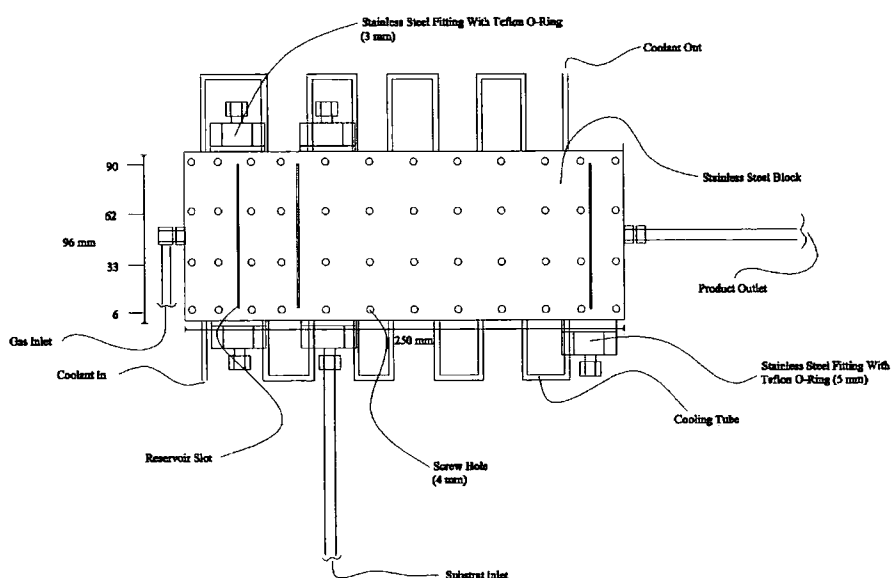

Fig 9.14: Top view of the V-21 microreactor

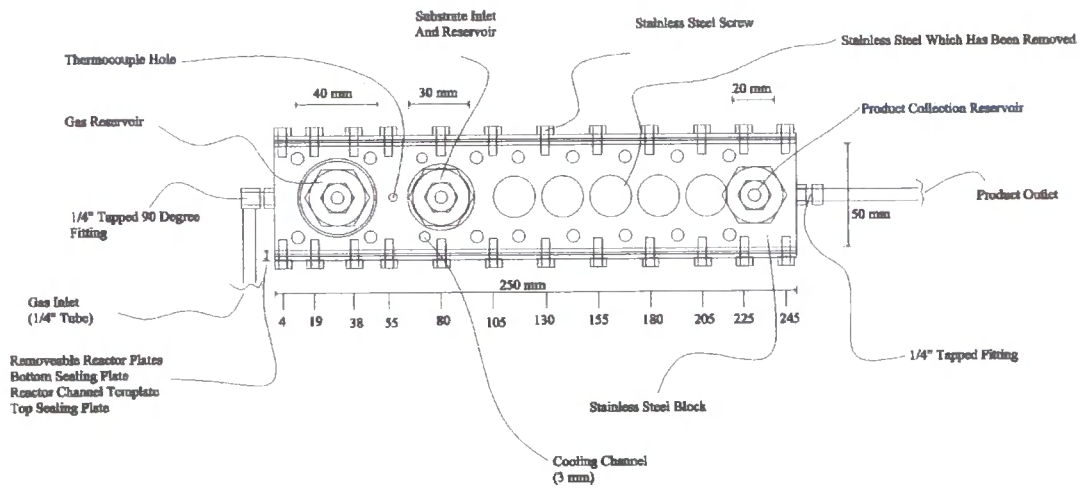

Fig 9.15: Side view of the V-21 microreactor

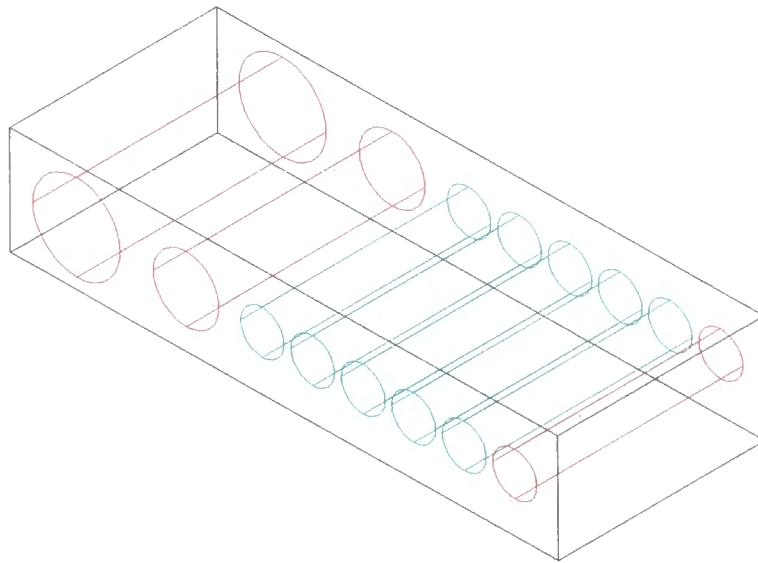

Fig 9.16: Diagram showing the stainless steel block (in black), reservoirs (in red), and support holes (in green)

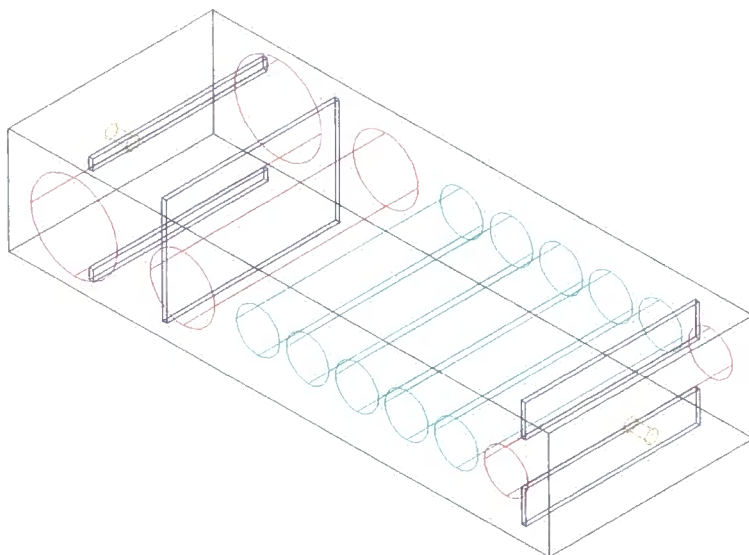

Fig 9.17: Depicts addition of reservoir to block surface slots (in blue) and gas/ product collection reservoir inlet/ outlet (in yellow)

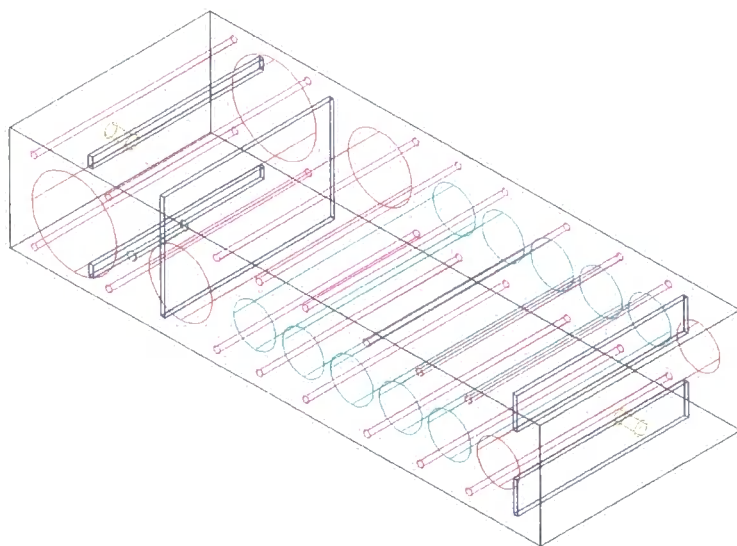

Fig 9.18: Diagram showing the addition of cooling channel holes (in purple)

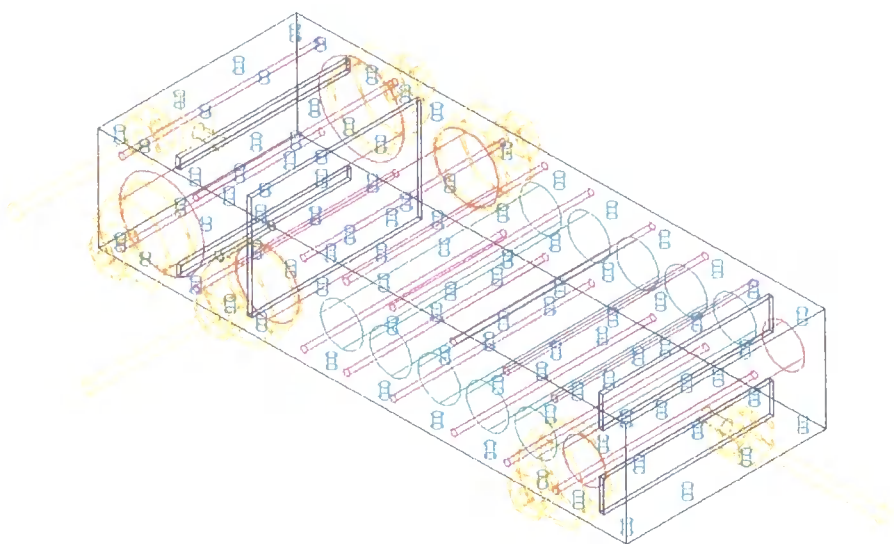

Fig 9.19: Depicts addition of fittings (in orange); the final assembly of the microreactor block. (N.B. external cooling tubes not shown for clarity.)

The nickel bottom plate was fabricated from 2mm thick nickel sheet, while slots were machined using wire EDM, as shown in figure 9.20. The channel template plate was fabricated from 0.5mm thick stainless steel sheet. Channels were added to the template plate by the use of chemical etching, depicted in figures 9.21 to 9.24. The top sealing plate was fabricated from a 6mm PTFCE sheet. The cover plate was fabricated from a 2mm thick stainless steel sheet, and view slots were machined into the cover sheet using a milling machine. The reverse side of the reactor was sealed with a 6mm PTFCE sheet and 2mm thick stainless steel sheet. All other sheet dimensions were analogous to the size of the reactor surface. To ensure that all the screw holes were drilled in exactly the same position as the reactor block, a screw hole template was fabricated from heavy gauge 8mm thick steel, which is shown in figures 9.25 and 9.26. Gaskets were made from 0.15mm thick copper, 0.15mm thick lead, or 0.05mm thick PTFE; the copper gaskets were subsequently annealed prior to use by heating to redness and then plunging into a methanol bath immediately. Stainless steel screws of 4mm diameter were used to attach the plates to the reactor block. A torque wrench was used to ensure that equal pressure was applied to each screw.

Prior to use, the reactor was leak tested and passivated using 10%, 20%, and 50% F_2/N_2 mixtures. When in use, the microreactor was held in a vertical position by two stainless steel bars, which were inserted through the holes in the block and clamped at either end.



Fig 9.20: Nickel bottom plate; gasket directly analogous

3 x 1 0.5 mm Slots



Fig 9.21: Channel template plate with three channels

**3 x 3 0.5 mm Slots
Separated By 3.5 mm**

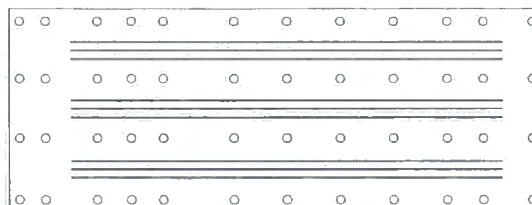

Fig 9.22: Channel template plate with nine channels

3 x 10 0.5 mm Slots
Separated By 1.5 mm

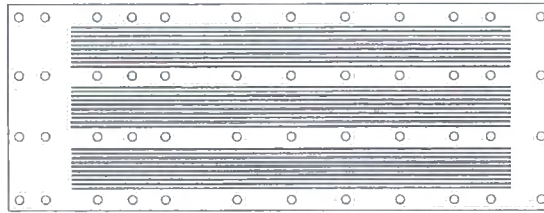

Fig 9.23: Channel template with thirty channels

3 x 19 0.5 mm Slots
Separated By 0.5 mm

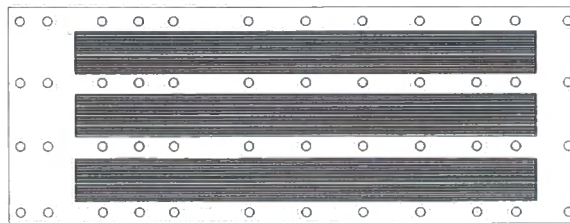

Fig 9.24: Channel template with fifty-seven channels

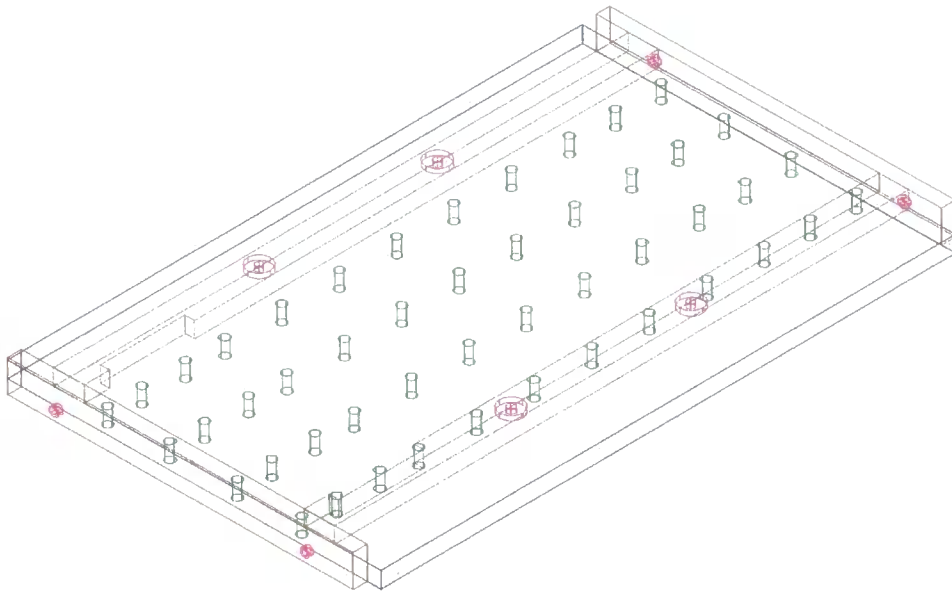

Fig 9.24: Diagram of the reactor hole template design

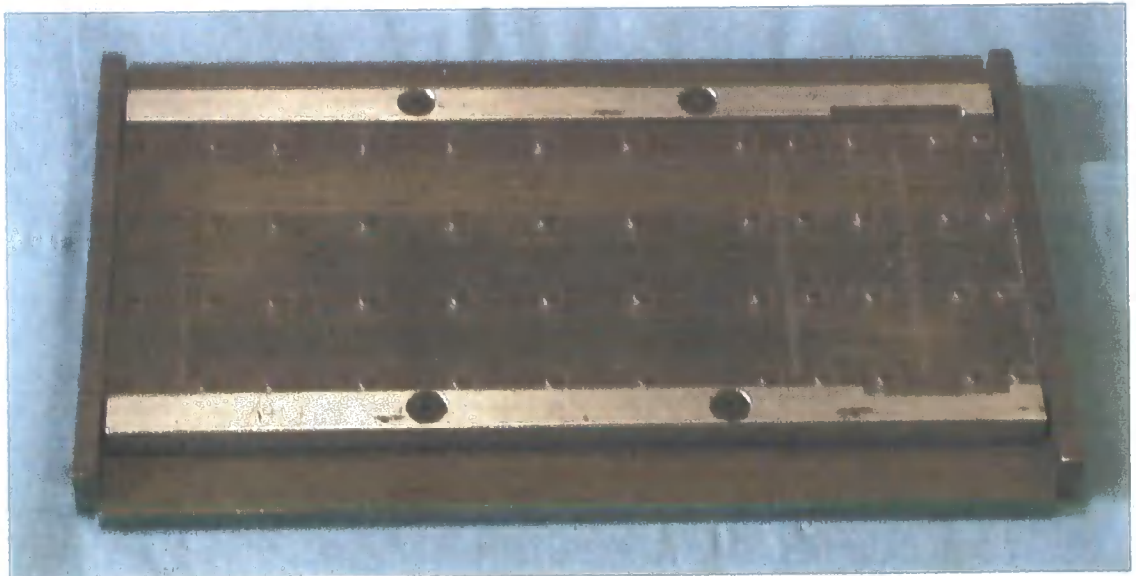

Fig 9.25: Photograph of the reactor hole template

Chapter 10.0: Experimental Section to Chapter 6.0

10.1 Direct Fluorination Using Microreactor Technology

10.1.1 General Procedure

The reactions below follow the procedure described, unless otherwise stated. Reaction apparatus was purged with nitrogen thoroughly, before and after fluorination. Fluorine as a 10 % mixture in nitrogen (v:v) is passed through the MR at a rate of $10 \text{ mlmin}^{-1}\text{ch}^{-1}$ ($2.6 \text{ mmolh}^{-1}\text{ch}^{-1}$); gas flow controlled by a mass flow controller (Brooks[®] Instruments). Reaction mixture was passed through the microreactor at a rate of $0.5 \text{ mlh}^{-1}\text{ch}^{-1}$; flow controlled by a syringe pump. Microreactor cooled to reaction temperature by an external cryostat, the main collection vessel was also cooled to reaction temperature; a secondary collection vessel located down-stream of the main collection vessel was cooled by dry ice. Analysis of the crude product by g.c. and g.c.m.s. analysis gave the % conversion and % yield. ($\text{mlmin}^{-1}\{\text{h}^{-1}\}\text{ch}^{-1}$ = millilitres per minute {per hour}, per channel) ($\text{mmolh}^{-1}\text{ch}^{-1}$ = millimoles per hour, per channel)

10.2 Single Channel Microreactor General Procedure

The reactions below follow the procedure described, unless otherwise stated. Microreactor (MR) was cooled to reaction temperature (5°C) by an external cryostat. Fluorine was passed through the MR at a rate of $10 \text{ mlmin}^{-1}/2.6 \text{ mmolh}^{-1}$ in total. Reaction mixture was passed through the microreactor at a rate of 0.5 mlh^{-1} in total. General work-up involves pouring the reaction mixture onto water (20 ml), followed by extraction by several portions of dichloromethane, these are combined and washed with saturated sodium hydrogen carbonate solution (10 ml), after which, the organic phase was dried over magnesium sulfate. Solvent is removed by rotary evaporation, giving the crude product.

10.2.1 Direct fluorination of ethyl 3-oxobutanoate (70)

Ethyl 3-oxobutanoate (2.0g, 15 mmol) was dissolved in methanoic acid (2.0g, 43 mmol) and passed through the MR at a rate of $2.2 \text{ mmolh}^{-1}\text{ch}^{-1}$ (0.29gh^{-1}). Gave a colourless oil 2.0g; conversion was found to be 98%, which consisted of, 71% ethyl 2-fluoro-3-

oxobutanoate (0.23gh^{-1}), 12% ethyl 2,4-difluoro-3-oxobutanoate, and 3% 2,2-difluoro-3-oxobutanoate. (As compared to literature data.¹⁰⁶)

Ethyl 2-fluoro-3-oxobutanoate was separated on silica using dichloromethane as elutant.

Ethyl 2-fluoro-3-oxobutanoate (71): 0.2 g; Colourless oil; $\delta^1\text{H}$ (200MHz; CDCl_3) 1.29 (t, 3H, $^3\text{J}_{\text{HH}}$ 7.0, CH_2CH_3), 2.31 (d, 3H, $^4\text{J}_{\text{HF}}$ 4.0, CH_3CO), 4.28 (q, 2H, $^3\text{J}_{\text{HH}}$ 7.2, OCH_2), 5.18 (d, 1H, $^2\text{J}_{\text{HF}}$ 49.4, CHF); $\delta^{19}\text{F}$ (188 MHz; CDCl_3) -193.7 (dq, $^2\text{J}_{\text{HF}}$ 49.3, $^4\text{J}_{\text{HF}}$ 3.8); $\delta^{13}\text{C}$ (100MHz; CDCl_3) 198.9 (d, $^2\text{J}_{\text{CF}}$ 23.5, C_2), 163.9 (d, $^2\text{J}_{\text{CF}}$ 23.9, C_4), 91.4 (d, $^1\text{J}_{\text{CF}}$ 196.9, C_3), 62.6 (s, C_5), 25.9 (s, C_1), 13.9 (s, C_6); ν_{max} (KBr plates)/ cm^{-1} 3650, 3463, 2986, 2943, 2912, 1765, 1737; found: C, 48.55; H, 6.0. $\text{C}_6\text{H}_9\text{FO}_3$ requires: C, 48.65; H, 6.08%; m/z (CI) 166 ($[\text{M}-\text{NH}_4]^+$, 100%).

Ethyl 2,4-difluoro-3-oxobutanoate (not isolated) (72): $\delta^{19}\text{F}$ (188MHz; CDCl_3) -203.2 (d, $^2\text{J}_{\text{HF}}$ 47.6, F_2), -235.2 (td, $^2\text{J}_{\text{HF}}$ 43.8, $^4\text{J}_{\text{HF}}$ 2.8, F_4); m/z (CI) 184 ($[\text{M}-\text{NH}_4]^+$, 66%), 166 (100), 148 (53), 52 (97).

Ethyl 2,2-difluoro-3-oxobutanoate (not isolated) (73): $\delta^{19}\text{F}$ (188MHz; CDCl_3) -113.8 (s).

10.2.2 Direct fluorination of ethyl 2-methyl-3-oxobutanoate (74)

Ethyl 2-methyl-3-oxobutanoate (2.0g, 14 mmol) was dissolved in methanoic acid (2.0g, 43 mmol) and passed through the MR at a rate of $1.9\text{mmolh}^{-1}\text{ch}^{-1}$ (0.27gh^{-1}). Gave a yellow oil 1.9g; conversion was found to be 52%, which consisted of, 49% ethyl 2-fluoro-2-methyl-3-oxobutanoate (0.08gh^{-1}) and 11% ethyl 2,4-difluoro-2-methyl-3-oxobutanoate. (As compared to literature data.¹⁰⁶)

Ethyl 2-fluoro-3-oxobutanoate (not isolated) (75): $\delta^{19}\text{F}$ (188MHz, CDCl_3) -157.4 (qq, $^3\text{J}_{\text{HF}}$ 22.0, $^4\text{J}_{\text{HF}}$ 4.5); m/z (CI) 180 ($[\text{M}-\text{NH}_4]^+$, 100%); $[\text{M}-\text{NH}_4]^+$, 180.1035. $\text{C}_7\text{H}_{15}\text{FNO}_3$ requires $[\text{M}-\text{NH}_4]^+$, 180.1036.

Ethyl 2,4-difluoro-3-oxobutanoate (not isolated) (76): $\delta^{19}\text{F}$ (188MHz, CDCl_3) -166.4 (1F, q, $^3\text{J}_{\text{HF}}$ 22.0, F_2), -236.0 (1F, td, $^2\text{J}_{\text{HF}}$ 45.7, $^5\text{J}_{\text{HF}}$ 3.6, F_4); m/z (CI) 198 ($[\text{M}-\text{NH}_4]^+$, 57%), 180 (70), 52 (100).

10.2.3 Direct fluorination of 3-acetyl-3,4,5-trihydrofuran-2-one (77)

3-Acetyl-3,4,5-trihydrofuran-2-one (2.0g, 12 mmol) was dissolved in methanoic acid (2.3g, 49 mmol) and passed through the MR at a rate of $2.4 \text{ mmolh}^{-1}\text{ch}^{-1}$ (0.31 gh^{-1}). Gave a yellow oil 1.8g; conversion was found to be 66%, which consisted of, 95% 3-acetyl-3-fluoro-3,4,5-trihydrofuran-2-one (0.22 gh^{-1}) and 4% 3-fluoro-3-(2-fluoroacetyl)-3,4,5-trihydrofuran-2-one. 3-Acetyl-3-fluoro-3,4,5-trihydrofuran-2-one was isolated on silica using dichloromethane as elutant. (As compared to literature data.¹⁰⁶)

3-Acetyl-3-fluoro-3,4,5-trihydrofuran-2-one (78): 0.3g; Colourless oil; $\delta^1\text{H}$ (200MHz; CDCl_3) 2.44 (3H, d, $^4\text{J}_{\text{HF}}$ 5.0, CH_3), 2.61 (1H, m), 2.82 (1H, m), 4.47 (2H, m, CH_2O); $\delta^{19}\text{F}$ (188MHz; CDCl_3) -162.6 (m); $\delta^{13}\text{C}$ (100MHz; CDCl_3) 203.1 (d, $^2\text{J}_{\text{CF}}$ 31.1, C_6), 169.1 (d, $^2\text{J}_{\text{CF}}$ 23.9, C_2), 96.2 (d, $^1\text{J}_{\text{CF}}$ 203.2, C_3), 65.6 (d, $^3\text{J}_{\text{CF}}$ 5.0, C_5), 31.9 (d, $^2\text{J}_{\text{CF}}$ 20.8, C_4), 25.8 (s, C_7); ν_{max} (KBr plates)/ cm^{-1} 2990, 2928, 1792, 1725; found C, 49.39, H, 4.99. $\text{C}_6\text{H}_7\text{FO}_3$ requires: C, 49.31, H, 4.79%; m/z (EI^+) 104 ($[\text{M}-\text{C}_2\text{H}_2\text{O}]^+$, 24%), 59 (11), 43 (100).

3-Fluoro-3-(2-fluoroacetyl)-3,4,5-trihydrofuran-2-one (not isolated) (79): $\delta^{19}\text{F}$ -172.9 (m, 1F, F_3), -236.8 (td, 1F, $^2\text{J}_{\text{HF}}$ 46, $^4\text{J}_{\text{FF}}$ 7, COCH_2F), m/z (EI^+) 136 ($[\text{M}-\text{CO}]^+$, 4%), 87 (100).

10.2.4 Direct fluorination of 2-acetylcyclohexan-1-one (80)

2-Acetylcyclohexan-1-one (2.0g, 14 mmol) was dissolved in methanoic acid (2.0g, 43 mmol) and passed through the MR at a rate of $1.9 \text{ mmolh}^{-1}\text{ch}^{-1}$ (0.27 gh^{-1}). Gave a yellow oil 2.1g; conversion was found to be 93%, which consisted of, 78% 2-acetyl-2-fluorocyclohexan-1-one (0.22 gh^{-1}) and 9% 2-fluoro-2-(2-fluoroacetyl)-cyclohexan-1-one. 2-Acetyl-2-fluorocyclohexan-1-one was separated on silica using dichloromethane as elutant. (As compared to literature data.¹⁰⁶)

2-Acetyl-2-fluoro-cyclohexan-1-one (81): 0.3 g; yellow oil; $\delta^1\text{H}$ (500MHz; CDCl_3) 2.67 (m, 2H), 2.31-2.41 (m, 1H), 2.29 (d, 3H, $^4\text{J}_{\text{HF}}$ 5.5, CH_3), 1.76-2.04 (m, 5H); $\delta^{19}\text{F}$ (188MHz; CDCl_3) -157.7 (m); $\delta^{13}\text{C}$ (126MHz; CDCl_3) 204.6 (d, $^2\text{J}_{\text{CF}}$ 31.0, C_7), 202.6 (d, $^2\text{J}_{\text{CF}}$ 18.0, C_1), 101.4 (d, $^1\text{J}_{\text{CF}}$ 196.6, C_2), 40.1 (s, C_6), 35.8 (d, $^2\text{J}_{\text{CF}}$ 21.0, C_3), 26.4 (s, C_5),

26.1 (s, C₈), 21.1 d, ³J_{CF} 6.9, C₄); m/z (EI) 158 (M⁺, 0.87%), 43 (100); M⁺, 158.0739. C₈H₁₁FO₂ requires M⁺, 158.0743.

2-Fluoro-2-(2-fluoroacetyl)-cyclohexan-1-one (not isolated) (82): δ¹⁹F (188MHz; CDCl₃) -169.6 (br.s), -236.4 (td, ²J_{HF} 46.8 ⁴J_{FF} 7.3, COCH₂F); m/z (EI) 176 (M⁺, 3%), 95 (100), 42 (85).

10.2.5 Direct fluorination of ethyl 2-oxocyclohexane carboxylate (83)

Ethyl 2-oxocyclohexane carboxylate (2.0g, 12 mmol) was dissolved in methanoic acid (2.0g, 43 mmol) and passed through the MR at a rate of 1.7 mmolh⁻¹ch⁻¹ (0.29gh⁻¹). Gave a yellow oil 2.0g; conversion was found to be 86%, which consisted of, 76% ethyl 1-fluoro-2-oxocyclohexane carboxylate (0.21gh⁻¹). Ethyl 1-fluoro-2-oxocyclohexane carboxylate was isolated on silica using dichloromethane as elutant. (As compared to literature data.¹⁰⁶)

Ethyl 1-fluoro-2-oxocyclohexane carboxylate (84): 0.3g; yellow oil; δ¹H (200MHz; CDCl₃) 1.28 (t, 3H, ³J_{HH} 7.0, CH₃), 1.86 (m, 4H), 1.98-2.77 (m, 4H), 4.25 (q, 2H, ³J_{HH} 7.0, CH₂); δ¹⁹F (188MHz; CDCl₃) -161.2 (tm, ³J_{HF} 17.3); δ¹³C (100MHz; CDCl₃) 201.7 (d, ²J_{CF} 19.7, C₂), 166.7 (d, ²J_{CF} 24.6, C₇), 96.2 (d, ¹J_{CF} 195.3, C₁), 62.2 (s, C₈), 39.5 (s, C₃), 35.8 (d, ²J_{CF} 21.6, C₆), 26.4 (s, C₄), 20.8 (d, ³J_{CF} 6.1, C₅), 13.8 (s, C₉); ν_{max} (KBr plates)/cm⁻¹ 2949, 2871, 1757, 1734; found: C, 57.19, H, 6.94. C₉H₁₃FO₃ requires: C, 57.45, H, 6.91%; m/z (EI⁺) 188 (M⁺, 2%), 67 (98), 55 (55), 39 (73), 29 (100), 27 (69).

10.3 Triple Channel Microreactor General Procedure

The reactions below follow the procedure described, unless otherwise stated. Microreactor (MR) was cooled to reaction temperature (5°C) by an external cryostat. Fluorine was passed through the MR at a rate of 30 mlmin⁻¹/ 7.8 mmolh⁻¹ in total. Reaction mixture was passed through the microreactor at a rate of 1.5 mlh⁻¹ in total. General work-up involves pouring the reaction mixture onto water (100 ml), followed by extraction by several portions of dichloromethane, these are combined and washed with saturated sodium hydrogen carbonate solution (25 ml), after which, the organic phase was dried over magnesium sulfate. Solvent is removed by rotary evaporation, giving the crude product.

10.3.1 1,3-Dicarbonyl Compounds

10.3.1.1 Direct fluorination of ethyl 3-oxobutanoate (70)

Experiment 1: Ethyl 3-oxobutanoate (6.0g, 46 mmol) was dissolved in methanoic acid (6.0g, 130 mmol) and passed through the MR maintained at 18°C, at a rate of 2.1 mmolh⁻¹ch⁻¹ (0.82gh⁻¹), for a period of 4.0hrs. Gave a colourless oil 3.6g; conversion was found to be 53%, which consisted of, 87% ethyl 2-fluoro-3-oxobutanoate (0.43gh⁻¹).

Experiment 2: Ethyl 3-oxobutanoate (6.0g, 46 mmol) was dissolved in methanoic acid (6.0g, 130 mmol) and passed through the MR at a rate of 2.1 mmolh⁻¹ch⁻¹ (0.82gh⁻¹) for a period of 5.0hrs. Gave a colourless oil 7.2g; conversion was found to be 66%, which consisted of, 71% ethyl 2-fluoro-3-oxobutanoate (0.44gh⁻¹).

Experiment 3: Ethyl 3-oxobutanoate (15.0g, 115 mmol) was dissolved in methanoic acid (15.0g, 326 mmol) and passed through the MR at a rate of 2.1 mmolh⁻¹ch⁻¹ (0.82gh⁻¹) for a period of 18.0hrs. Gave a colourless oil 13.1g; conversion was found to be 77%, which consisted of, 87% ethyl 2-fluoro-3-oxobutanoate (0.62gh⁻¹).

Experiment 4: (Utilised product outlet tubes which were 50 mm longer) Ethyl 3-oxobutanoate (24.0g, 185 mmol) was dissolved in methanoic acid (24.0g, 522 mmol) and passed through the MR at a rate of 2.1 mmolh⁻¹ch⁻¹ (0.82gh⁻¹) for a period of 24.0hrs. Gave a colourless oil 25.0g; conversion was found to be 91%, which consisted of, 65% ethyl 2-fluoro-3-oxobutanoate (0.55gh⁻¹).

Experiment 5: Ethyl 3-oxobutanoate (20.0g, 154 mmol) was dissolved in methanoic acid (20.0g, 435 mmol) and passed through the MR maintained at 0°C, at a rate of 2.1 mmolh⁻¹ch⁻¹ (0.82gh⁻¹) for a period of 6.0hrs. Gave a colourless oil 5.5g; conversion was found to be 79%, which consisted of, 94% ethyl 2-fluoro-3-oxobutanoate (0.69gh⁻¹).

Experiment 6: Ethyl 3-oxobutanoate (22.0g, 169 mmol) was dissolved in methanoic acid (22.0g, 478 mmol) and passed through the MR maintained at 0°C, at a rate of 2.1 mmolh⁻¹ch⁻¹ (0.82gh⁻¹) for a period of 18.6hrs. Gave a colourless oil 24.1g; conversion was found to be 70%, which consisted of, 96% ethyl 2-fluoro-3-oxobutanoate (0.63gh⁻¹).

10.3.1.2 Direct fluorination of ethyl 2-methyl-3-oxobutanoate (74)

Experiment 1: Ethyl 2-methyl-3-oxobutanoate (13.0g, 90 mmol) was dissolved in methanoic acid (12.4g, 270 mmol) and passed through the MR at a rate of 2.0 mmolh⁻¹ch⁻¹

¹ (0.86gh⁻¹) for a period of 12.0hrs. Gave a yellow oil 10.9g; conversion was found to be 47%, which consisted of, 38% ethyl 2-fluoro-2-methyl-3-oxobutanoate (0.17gh⁻¹).

Experiment 2: (Utilised product outlet tubes which were 50 mm longer) Ethyl 2-methyl-3-oxobutanoate (6.6g, 46 mmol) was dissolved in methanoic acid (22.8g, 496 mmol) and passed through the MR at a rate of 0.8 mmolh⁻¹ch⁻¹ (0.35gh⁻¹) for a period of 9.0hrs. Gave a yellow oil 6.3g; conversion was found to be 67%, which consisted of, 40% ethyl 2-fluoro-2-methyl-3-oxobutanoate (0.10gh⁻¹).

10.3.1.3 Direct fluorination of 2-acetylcyclohexan-1-one (80)

Experiment 1: 2-Acetylcyclohexan-1-one (9.8g, 70 mmol) was dissolved in methanoic acid (9.8g, 213 mmol) and passed through the MR at a rate of 2.0 mmolh⁻¹ch⁻¹ (0.84gh⁻¹) for a period of 10.0hrs. Gave a yellow oil 9.6g; conversion was found to be 53%, which consisted of, 75% 2-acetyl-2-fluorocyclohexan-1-one (0.38gh⁻¹).

Experiment 2: (Utilised product outlet tubes which were 50 mm longer) 2-Acetylcyclohexan-1-one (10.0g, 71 mmol) was dissolved in methanoic acid (15.0g, 326 mmol) and passed through the MR at a rate of 1.5 mmolh⁻¹ch⁻¹ (0.63gh⁻¹) for a period of 8.0hrs. Gave a yellow oil 9.6g; conversion was found to be 95%, which consisted of, 67% 2-acetyl-2-fluorocyclohexan-1-one (0.45gh⁻¹).

Experiment 3: (Utilised product outlet tubes which were 50 mm longer) 2-Acetylcyclohexan-1-one (8.7g, 62 mmol) was dissolved in methanoic acid (13.0g, 283 mmol) and passed through the MR at a rate of 1.9 mmolh⁻¹ch⁻¹ (0.80gh⁻¹) for a period of 11.0hrs. Gave a yellow oil 9.0g; conversion was found to be 99%, which consisted of, 65% 2-acetyl-2-fluorocyclohexan-1-one (0.58gh⁻¹).

10.3.1.4 Direct fluorination of ethyl 2-chloro-3-oxobutanoate (85)

(Utilised product outlet tubes which were 50 mm longer) Ethyl 2-chloro-3-oxobutanoate (14.0g, 86 mmol) was dissolved in methanoic acid (31.8g, 691 mmol) and passed through the MR at a rate of 0.9 mmolh⁻¹ch⁻¹ (0.44gh⁻¹) for a period of 14.0hrs. Gave a colourless oil 9.2g; conversion was found to be 59%, which consisted of, 74% ethyl 2-chloro-2-fluoro-3-oxobutanoate (0.22gh⁻¹). (As compared to literature data.¹⁰⁶)

Ethyl 2-chloro-2-fluoro-3-oxobutanoate (not purified) (86): δ_F (188 MHz; $CDCl_3$) – 123.4 (s); m/z (EI^+) 183 ($M^+\{^{35}Cl\}$, 3 %), 140 (76), 112, (92), 109 (74), 91 (58), 44 (52), 43 (100), 29 (73), 27 (68); $M^+\{^{35}Cl\}$, 182.0151. $C_6H_8^{35}ClFO_3$ requires M^+ , 182.0146.

10.3.2 Aromatic Compounds

10.3.2.1 1-Methyl-4-nitrobenzene General Procedure

The reactions below follow the procedure described, unless otherwise stated. Reaction solvent consists of acetonitrile/ methanoic acid in a 3:2 ratio; typically, 50ml. The solution was passed through the MR for a period of 18.0hrs.

Direct fluorination of 1-methyl-4-nitrobenzene (87)

Experiment 1: 1-methyl-4-nitrobenzene (9.8g, 72 mmol) was dissolved in acetonitrile (48ml) and passed through the MR maintained at 20°C, at a rate of 1.0 $mlh^{-1}ch^{-1}$ (3.0 mlh^{-1} in total), 1.5 $mmolh^{-1}ch^{-1}$ (0.62 gh^{-1}), for a period of 14.0hrs. Gave a yellow oil 11.2g; conversion was found to be 15%, which consisted of, 71% 1-fluoro-2-methyl-5-nitrobenzene (0.07 gh^{-1}). (As compared to literature data.⁸¹)

Experiment 2: 1-methyl-4-nitrobenzene (5.9g, 43 mmol), at a rate of 1.0 $mlh^{-1}ch^{-1}$ (3.0 mlh^{-1} in total), 0.9 $mmolh^{-1}ch^{-1}$ (0.37 gh^{-1}). Gave a yellow oil 14.3g; conversion was found to be 44%, which consisted of, 78% 1-fluoro-2-methyl-5-nitrobenzene (0.14 gh^{-1}).

Experiment 3: 1-methyl-4-nitrobenzene (5.9g, 43 mmol), passed through the MR maintained at 0°C, at a rate of 1.0 $mlh^{-1}ch^{-1}$ (3.0 mlh^{-1} in total), 0.9 $mmolh^{-1}ch^{-1}$ (0.37 gh^{-1}). Gave a yellow oil 16.6g; conversion was found to be 66%, which consisted of, 71% 1-fluoro-2-methyl-5-nitrobenzene (0.20 gh^{-1}).

Experiment 4: 1-methyl-4-nitrobenzene (3.0g, 22 mmol), at a rate of 2.0 $mlh^{-1}ch^{-1}$ (6.0 mlh^{-1} in total), 0.9 $mmolh^{-1}ch^{-1}$ (0.37 gh^{-1}). Gave a yellow oil 6.2g; conversion was found to be 53%, which consisted of, 60% 1-fluoro-2-methyl-5-nitrobenzene (0.13 gh^{-1}).

Experiment 5: 1-methyl-4-nitrobenzene (3.0g, 22 mmol), passed through the MR maintained at 0°C, at a rate of 2.0 $mlh^{-1}ch^{-1}$ (6.0 mlh^{-1} in total), 0.9 $mmolh^{-1}ch^{-1}$ (0.37 gh^{-1}). Gave a yellow oil 4.5g; conversion was found to be 86%, which consisted of, 54% 1-fluoro-2-methyl-5-nitrobenzene (0.19 gh^{-1}).

Experiment 6: 1-methyl-4-nitrobenzene (3.0g, 22 mmol), passed through the MR maintained at 0°C, at a rate of 2.0 mlh⁻¹ch⁻¹ (6.0 mlh⁻¹ in total), 0.9 mmolh⁻¹ch⁻¹ (0.37gh⁻¹). Gave a yellow oil 3.5g; conversion was found to be 77%, which consisted of, 66% 1-fluoro-2-methyl-5-nitrobenzene (0.21gh⁻¹).

Experiment 7: (Utilised product outlet tubes which were 50 mm longer) 1-methyl-4-nitrobenzene (3.0g, 22 mmol), passed through the MR maintained at 0°C, at a rate of 2.0 mlh⁻¹ch⁻¹ (6.0 mlh⁻¹ in total), 0.9 mmolh⁻¹ch⁻¹ (0.37gh⁻¹), for a period of 6.5hrs. Gave a yellow oil 4.9g; conversion was found to be 80%, which consisted of, 51% 1-fluoro-2-methyl-5-nitrobenzene (0.17gh⁻¹).

Experiment 8: (Utilised product outlet tubes which were 50 mm longer) 1-methyl-4-nitrobenzene (3.0g, 22 mmol), passed through the MR maintained at 0°C, at a rate of 2.0 mlh⁻¹ch⁻¹ (6.0 mlh⁻¹ in total), 0.9 mmolh⁻¹ch⁻¹ (0.37gh⁻¹), for a period of 8.0hrs. Gave a yellow oil 4.5g; conversion was found to be 86%, which consisted of, 56% 1-fluoro-2-methyl-5-nitrobenzene (0.19gh⁻¹).

1-Fluoro-2-methyl-5-nitrobenzene (not isolated) (88): δ_F (188 MHz; CDCl₃) -113.5 (m); m/z (EI⁺) 155 (M⁺, 100 %), 125 (82), 109, (96), 107 (66), 97 (58), 83 (93), 63 (54), 57 (58); M⁺, 155.038678. C₇H₆FNO₂ requires M⁺, 155.038257.

10.3.2.2 1-Methyl-2,4-dinitrobenzene General Procedure

The reactions below follow the procedure described, unless otherwise stated. Reaction solvent consists of acetonitrile/ methanoic acid in a 3:2 ratio; typically, 50ml. The solution was passed through the MR at a rate of 2 mlh⁻¹ch⁻¹ (6.0 mlh⁻¹ in total), 0.9 mmolh⁻¹ch⁻¹ (0.49gh⁻¹) for a period of 18.0hrs.

Direct fluorination of 1-methyl-2,4-dinitrobenzene (89)

Experiment 1: 1-methyl-2,4-dinitrobenzene (4.0g, 22 mmol). Gave a yellow oil 7.9g; conversion was found to be 40%, which consisted of, 70% 1-fluoro-2-methyl-3,5-dinitrobenzene (0.15gh⁻¹).

Experiment 2: 1-methyl-2,4-dinitrobenzene (4.0g, 22 mmol). Gave a yellow oil 4.6g; conversion was found to be 40%, which consisted of, 66% 1-fluoro-2-methyl-3,5-dinitrobenzene (0.14gh⁻¹).

Experiment 3: (Utilised product outlet tubes which were 50 mm longer) 1-methyl-2,4-dinitrobenzene (4.0g, 22 mmol), passed through the MR maintained at 0°C, for a period of 6.5hrs. Gave a yellow oil 3.8g; conversion was found to be 48%, which consisted of, 68% 1-fluoro-2-methyl-3,5-dinitrobenzene (0.18gh⁻¹).

Experiment 4: (Utilised product outlet tubes which were 50 mm longer) 1-methyl-2,4-dinitrobenzene (4.0g, 22 mmol), passed through the MR maintained at 0°C, for a period of 8.0hrs. Gave a yellow oil 5.5g; conversion was found to be 51%, which consisted of, 66% 1-fluoro-2-methyl-3,5-dinitrobenzene (0.18gh⁻¹). 1-Fluoro-2-methyl-3,5-dinitrobenzene was isolated on silica using 40-60 petroleum ether/ diethyl ether (1:1) as elutant. (As compared to literature data.²⁹⁶)

1-Fluoro-2-methyl-3,5-dinitrobenzene (90): 0.4 g; yellow oil; $\delta^1\text{H}$ (200 MHz; CDCl₃) 2.59 (d, 3H, ⁴J_{HF} 2.2, Me), 8.16 (dd, 1H, ³J_{HF} 8.4, ⁴J_{HH} 2.4, H₅), 8.61 (br.s, 1H, H₃); $\delta^{19}\text{F}$ (188 MHz; CDCl₃) -106.2 (d, ³J_{HF} 8.3); $\delta^{13}\text{C}$ (100 MHz; CDCl₃) 161.0 (d, ¹J_{CF} 252.2, C6), 150.1 (s, C3), 146.0 (d, ³J_{CF} 9.8, C4), 129.2 (d, ²J_{CF} 20.8, C5), 115.5 (d, ³J_{CF} 3.8, C2), 114.6 (d, ²J_{CF} 28.9, C1), 11.7 (d, ³J_{CF} 4.9, C7); ν_{max} (KBr plates)/cm⁻¹ 3106, 2852, 1590, 1538; m/z (EI⁺) 200 (M⁺, 56 %), 183 (100), 137, (71), 108 (70), 107 (94), 96 (54), 81 (74), 57 (53), 30 (66); M⁺, 200.023858. C₇H₅FN₂O₄ requires M⁺, 200.023335.

10.3.2.3 Direct fluorination of 3-nitrophenyl disulfide (91)

Two-Step (Bulk and Microreactor) General Procedure

The reactions below follow the procedure described, unless otherwise stated. 3-Nitrophenyl disulfide (2.0g, 6 mmol) was dissolved in acetonitrile (100ml) and cooled to 0°C. The solution was rapidly stirred using an overhead stirrer, typically at 350 revolutions min⁻¹. Fluorine (24 mmol, 4 equivalents) was bubbled through the solution at a rate of 25 mlmin⁻¹ (6.5 mmolh⁻¹). A sample was removed for ¹⁹F NMR analysis to determine 1-(trifluorosulfur)-3-nitrobenzene concentration. The resultant solution of 1-(trifluorosulfur)-3-nitrobenzene was passed through the microreactor maintained at 20°C, at a rate of 7.3 mlh⁻¹ch⁻¹. General work-up involves shaking the reaction mixture with potassium fluoride (~1g), solvent is removed by rotary evaporation, giving the crude product. All reactions were performed using product outlet tubes, which were 50 mm longer.

Preliminary experiment: At regular intervals, the flow of fluorine was stopped and the fluorination apparatus purged with nitrogen for 5 minutes. A 1ml sample was taken and this was compared to a known reference of trifluoromethylbenzene. This was repeated for several hours.

Experiment 1: Analysis showed a 75% yield of 1-(trifluorosulfur)-3-nitrobenzene (0.09 molml^{-1}) ($0.65 \text{ mmolh}^{-1}\text{ch}^{-1}$). Solution passed through the microreactor for a period of 2.8hrs. Gave an orange oil 2.4g; a 41% yield of 1-(pentafluorosulfur)-3-nitrobenzene (0.20gh^{-1}) was obtained.

Experiment 2: Analysis showed a 62% yield of 1-(trifluorosulfur)-3-nitrobenzene (0.07 molml^{-1}) ($0.51 \text{ mmolh}^{-1}\text{ch}^{-1}$). Solution passed through the microreactor for a period of 2.8hrs. Gave an orange oil 4.3g; a 56% yield of 1-(pentafluorosulfur)-3-nitrobenzene (0.24gh^{-1}) was obtained.

Experiment 3: Analysis showed a 56% yield of 1-(trifluorosulfur)-3-nitrobenzene (0.07 molml^{-1}) solution of 1-(trifluorosulfur)-3-nitrobenzene was passed through the microreactor at a rate of $5.0 \text{ mlh}^{-1}\text{ch}^{-1}$. ($0.34 \text{ mmolh}^{-1}\text{ch}^{-1}$). Solution passed through the microreactor for a period of 3.5hrs. Gave an orange oil 3.4g; a 52% yield of 1-(pentafluorosulfur)-3-nitrobenzene (0.14gh^{-1}) was obtained.

3-Nitrophenyl Disulfide One-Step (Microreactor) General Procedure

The reactions below follow the procedure described, unless otherwise stated. 3-Nitrophenyl disulfide (1.0g, 3 mmol) was dissolved in acetonitrile (50ml) and passed through the MR maintained at 20°C . General work-up involves shaking the reaction mixture with potassium fluoride (~1g), solvent is removed by rotary evaporation, giving the crude product. All reactions were performed using product outlet tubes, which were 50 mm longer.

Experiment 1: Solution passed through the microreactor at a rate of $2.0 \text{ mlh}^{-1}\text{ch}^{-1}$ (6.0 mlh^{-1} in total), $0.12 \text{ mmolh}^{-1}\text{ch}^{-1}$ (0.11gh^{-1}), for a period of 7.0hrs. Gave a yellow oil 7.5g; a 60% yield of 1-(pentafluorosulfur)-3-nitrobenzene (0.11gh^{-1}) was obtained.

Experiment 2: Solution passed through the microreactor at a rate of $1.0 \text{ mlh}^{-1}\text{ch}^{-1}$ (3.0 mlh^{-1} in total), $0.06 \text{ mmolh}^{-1}\text{ch}^{-1}$ (0.06gh^{-1}), for a period of 8.7hrs. Gave a yellow oil 5.8g; a 40% yield of 1-(pentafluorosulfur)-3-nitrobenzene (0.04gh^{-1}) was obtained.

Experiment 3: Solution passed through the microreactor at a rate of $2.5 \text{ mlh}^{-1}\text{ch}^{-1}$ (7.5 mlh^{-1} in total), $0.15 \text{ mmolh}^{-1}\text{ch}^{-1}$ (0.14gh^{-1}), for a period of 5.7hrs. 20% Fluorine was passed through the microreactor at a rate of $5.2 \text{ mmolh}^{-1}\text{ch}^{-1}$. Gave a yellow oil 7.7g; a 55% yield of 1-(pentafluorosulfur)-3-nitrobenzene (0.12gh^{-1}) was obtained.

Experiment 4: Solution passed through the microreactor at a rate of $3.5 \text{ mlh}^{-1}\text{ch}^{-1}$ (10.5 mlh^{-1} in total), $0.21 \text{ mmolh}^{-1}\text{ch}^{-1}$ (0.19gh^{-1}), for a period of 4.2hrs. 20% Fluorine was passed through the microreactor at a rate of $5.2 \text{ mmolh}^{-1}\text{ch}^{-1}$. Gave a yellow oil 4.8g; a 52% yield of 1-(pentafluorosulfur)-3-nitrobenzene (0.16gh^{-1}) was obtained.

Experiment 5: Solution passed through the microreactor at a rate of $2.0 \text{ mlh}^{-1}\text{ch}^{-1}$ (6.0 mlh^{-1} in total), $0.12 \text{ mmolh}^{-1}\text{ch}^{-1}$ (0.11gh^{-1}), for a period of 6.7hrs. 20% Fluorine was passed through the microreactor at a rate of $5.2 \text{ mmolh}^{-1}\text{ch}^{-1}$. Gave a yellow oil 7.4g; a 42% yield of 1-(pentafluorosulfur)-3-nitrobenzene (0.08gh^{-1}) was obtained.

Purification was achieved by chromatography on silica with dichloromethane as elutant. (As compared to literature data.¹⁴⁴)

1-(Pentafluorosulfur)-3-nitrobenzene (93): 0.4g; orange oil; $\delta^1\text{H}$ (500MHz; CDCl_3) 7.73 (1H, t, $^3\text{J}_{\text{HF}}$ 8.0, H₅), 8.11 (1H, dd, $^3\text{J}_{\text{HF}}$ 8.5 $^4\text{J}_{\text{HF}}$ 1.5, H₆), 8.42 (1H, d, $^3\text{J}_{\text{HF}}$ 8.5, H₄), 8.65 (1H, t, $^4\text{J}_{\text{HF}}$ 2.0, H₂); $\delta^{19}\text{F}$ (470MHz; CDCl_3) 80.7 (1F, p, $^2\text{J}_{\text{FF}}$ 150.4, SF_{ax}), 62.4 (4F, d, $^2\text{J}_{\text{FF}}$ 150.4, SF_{eq}); $\delta^{13}\text{C}$ (100MHz; CDCl_3) 154.1 (p, $^2\text{J}_{\text{CF}}$ 19.7, C₋₁), 148.1 (s, C₃), 131.7 (p, $^3\text{J}_{\text{CF}}$ 4.7, C₆), 130.1 (s, C₅), 126.4 (s, C₄), 121.8 (p, $^3\text{J}_{\text{CF}}$ 4.7, C₂); m/z (EI⁺) 249 (M⁺, 96%), 203 (87), 95, (100), 89 (94), 83 (69), 76 (85), 75 (94), 74 (77), 50 (78), 30 (59); M⁺, 248.9886. C₆H₄F₅NO₂S requires M⁺, 248.9883.

10.4 V-21-3 General Procedure

The reactions below follow the procedure described, unless otherwise stated. Microreactor (MR) was cooled to reaction temperature (10°C) by an external cryostat. Fluorine was passed through the MR at a rate of 30 mlmin^{-1} / 7.8 mmolh^{-1} in total. Reaction mixture was passed through the microreactor at a rate of 1.5 mlh^{-1} in total; $1.8 \text{ mmolh}^{-1}\text{ch}^{-1}$ (0.70gh^{-1}). General work-up involves pouring the reaction mixture onto water (300 ml), followed by extraction by several portions of dichloromethane, these are combined and washed with saturated sodium hydrogen carbonate solution (50 ml), after

which, the organic phase was dried over magnesium sulfate. Solvent is removed by rotary evaporation, giving the crude product.

10.4.1 Direct fluorination of ethyl 3-oxobutanoate (70)

Several identical reagent solutions were prepared; a typical solution consisted of ethyl 3-oxobutanoate (135.0g, 1.04 mmol) and methanoic acid (195.0g, 4.24 mol) (1:4.1 ratio respectively).

Experiment 1: Reaction duration 20.5hrs. Gave a colourless oil 24.47 g; conversion was found to be 75%, which consisted of, 92% ethyl 2-fluoro-3-oxobutanoate (0.55gh^{-1}).

Experiment 2: Reaction duration 20.0hrs. Gave a colourless oil 30.42 g; conversion was found to be 62%, which consisted of, 90% ethyl 2-fluoro-3-oxobutanoate (0.45gh^{-1}).

Experiment 3: Reaction duration 23.5hrs. Gave a colourless oil 31.63 g; conversion was found to be 76%, which consisted of, 92% ethyl 2-fluoro-3-oxobutanoate (0.56gh^{-1}).

Experiment 4: Reaction duration 23.0hrs. Gave a colourless oil 24.63 g; conversion was found to be 77%, which consisted of, 91% ethyl 2-fluoro-3-oxobutanoate (0.56gh^{-1}).

Experiment 5: Reaction duration 23.8hrs. Gave a colourless oil 26.66 g; conversion was found to be 74%, which consisted of, 90% ethyl 2-fluoro-3-oxobutanoate (0.53gh^{-1}).

Experiment 6: Reaction duration 24.0hrs. Gave a colourless oil 27.18 g; conversion was found to be 86%, which consisted of, 94% ethyl 2-fluoro-3-oxobutanoate (0.65gh^{-1}).

Experiment 7: Reaction duration 48.0hrs. Gave a colourless oil 42.83 g; conversion was found to be 71%, which consisted of, 91% ethyl 2-fluoro-3-oxobutanoate (0.52gh^{-1}).

Experiment 8: Fluorine was passed through the MR at a rate of $15\text{ mlmin}^{-1}\text{ch}^{-1}$ / $3.9\text{ mmolh}^{-1}\text{ch}^{-1}$ (45 mlmin^{-1} / 11.7 mmolh^{-1} in total). Reaction duration 18.0hrs. Gave a colourless oil 34.98 g; conversion was found to be 91%, which consisted of, 87% ethyl 2-fluoro-3-oxobutanoate (0.63gh^{-1}).

Experiment 9: Fluorine was passed through the MR at a rate of $15\text{ mlmin}^{-1}\text{ch}^{-1}$ / $3.9\text{ mmolh}^{-1}\text{ch}^{-1}$ (45 mlmin^{-1} / 11.7 mmolh^{-1} in total). Reaction duration 29.8hrs. Gave a colourless oil 47.09 g; conversion was found to be 93%, which consisted of, 86% ethyl 2-fluoro-3-oxobutanoate (0.64gh^{-1}).

Experiment 10: Reaction mixture was passed through the microreactor at a rate of $0.25\text{ mlh}^{-1}\text{ch}^{-1}$ (0.75 mlh^{-1} in total) $0.9\text{ mmolh}^{-1}\text{ch}^{-1}$ (0.35gh^{-1}). Reaction duration 23.0hrs.

Gave a colourless oil 26.66 g; conversion was found to be 77%, which consisted of, 91% ethyl 2-fluoro-3-oxobutanoate (0.32gh^{-1}).

10.4.2 Direct fluorination of 3-acetyl-3,4,5-trihydrofuran-2-one (77)

Several identical reagent solutions were prepared; a typical solution consisted of 3-acetyl-3,4,5-trihydrofuran-2-one (119.0g, 0.93 mmol) and methanoic acid (168.0g, 3.72 mol) (1:4 ratio respectively), $2.0\text{ molh}^{-1}\text{ch}^{-1}$ (0.71gh^{-1}).

Experiment 1: Reaction duration 28.0hrs. Gave a yellow oil 36.55 g; conversion was found to be 74%, which consisted of, 98% 3-acetyl-3-fluoro-3,4,5-trihydrofuran-2-one (0.64gh^{-1}).

Experiment 2: Reaction mixture was passed through the microreactor at a rate of $0.25\text{ mlh}^{-1}\text{ch}^{-1}$ (0.75 mlh^{-1} in total), $1.0\text{ mmolh}^{-1}\text{ch}^{-1}$ (0.35gh^{-1}). Reaction duration 50.0hrs. Gave a yellow oil 22.89 g; conversion was found to be 96%, which consisted of, 95% 3-acetyl-3-fluoro-3,4,5-trihydrofuran-2-one (0.40gh^{-1}).

10.5 General Procedure (V-21-9)

As previously described for the V-21-3. Fluorine was passed through the MR at a rate of $90\text{ mlmin}^{-1}/23.4\text{ mmolh}^{-1}$ or 46.8 mmolh^{-1} , 10% and 20% F_2 in total respectively. Reaction mixture was passed through the microreactor at a rate of 4.5 mlh^{-1} in total, $1.8\text{ mmolh}^{-1}\text{ch}^{-1}$ (2.11gh^{-1}).

10.5.1 Direct fluorination of ethyl 3-oxobutanoate (70) (10 % fluorine)

Several identical reagent solutions were prepared; a typical solution consisted of ethyl 3-oxobutanoate (270 g, 2.077 mol) and methanoic acid (380 g, 8.261 mol). The solution was passed through the MR for a period of 19 hrs in all experiments.

Experiment 1: Gave a colourless oil 115.16 g; conversion was found to be 74%, which consisted of, 91% ethyl 2-fluoro-3-oxobutanoate (1.61gh^{-1}).

Experiment 2: Gave a colourless oil 93.17 g; conversion was found to be 74%, which consisted of, 91% ethyl 2-fluoro-3-oxobutanoate (1.61gh^{-1}).

Experiment 3: Gave a colourless oil 42.00 g; conversion was found to be 63%, which consisted of, 92% ethyl 2-fluoro-3-oxobutanoate (1.39gh^{-1}).

Experiment 4: Gave a colourless oil 90.75 g; conversion was found to be 76%, which consisted of, 91% ethyl 2-fluoro-3-oxobutanoate (1.66gh^{-1}).

Experiment 5: Gave a colourless oil 41.61 g; conversion was found to be 75%, which consisted of, 91% ethyl 2-fluoro-3-oxobutanoate (1.64gh^{-1}).

Experiment 6: Gave a colourless oil 105.45 g; conversion was found to be 80%, which consisted of, 95% ethyl 2-fluoro-3-oxobutanoate (1.82gh^{-1}).

Experiment 7: Gave a colourless oil 100.91 g; conversion was found to be 78%, which consisted of, 91% ethyl 2-fluoro-3-oxobutanoate (1.70gh^{-1}).

Direct fluorination of ethyl 3-oxobutanoate (70) (20 % fluorine)

Experiment 1: Gave a colourless oil 136.45 g; conversion was found to be 83%, which consisted of, 87% ethyl 2-fluoro-3-oxobutanoate (1.73gh^{-1}).

Experiment 2: Gave a colourless oil 132.83 g; conversion was found to be 93%, which consisted of, 94% ethyl 2-fluoro-3-oxobutanoate (2.10gh^{-1}).

Appendix

References

- 1 J. Buckingham, 'Dictionary of Natural Products', Chapman and Hall, 1994.
- 2 D. B. Harper and D. O'Hagan, *Natural Product Reports*, 1994, 123.
- 3 D. O'Hagan and D. B. Harper, *J. Fluorine Chem.*, 1999, **100**, 127.
- 4 G. W. Gribble, 'Progress in the Chemistry of Organic Natural Products', Springer-Verlag, 1996.
- 5 N. N. Greenwood and A. Earnshaw, 'Chemistry of the Elements', Butterworth-Heinemann Ltd, 1995.
- 6 J. H. Simons, 'Fluorine Chemistry', Academic Press, 1964.
- 7 A. Jorissen, V. V. Smith, and D. L. Lambert, *Astron. Astrophys.*, 1992, **261**, 164.
- 8 D. A. Neufeld, J. Zmuidzinas, P. Schilke, and T. G. Phillips, *Astrophys. J.*, 1997, **488**, L141.
- 9 L. M. Ziurys, A. J. Apponi, and T. G. Phillips, *Astrophys. J.*, 1994, **433**, 729.
- 10 F. X. Timmes, S. E. Woosley, and T. A. Weaver, *Astrophys. J. Suppl. Ser.*, 1995, **98**, 617.
- 11 G. Wallerstein, I. Icko, P. Parker, A. M. Boesgaard, G. M. Hale, A. E. Champagne, C. A. Barnes, F. Kappeler, V. V. Smith, R. D. Hoffman, F. X. Timmes, C. Sneden, R. N. Boyd, B. S. Meyer, and D. L. Lambert, *Rev. Mod. Phys.*, 1997, **69**, 995.
- 12 G. Meynet and M. Arnould, *Astron. Astrophys.*, 2000, **355**, 176.
- 13 D. D. DesMarteau, *J. Fluorine Chem.*, 1982, **21**, 3.
- 14 J. E. Huheey, E. A. Keiter, and R. L. Keiter, 'Inorganic Chemistry', Harper Collins, 1993.
- 15 J. K. Nagle, *J. Am. Chem. Soc.*, 1990, **112**, 4741.
- 16 A. Bondi, *J. Phys. Chem.*, 1964, **68**, 441.
- 17 R. D. Chambers, *Chim. Ind. (Milan)*, 1997, **79**, 325.
- 18 K. C. Lowe, *J. Fluorine Chem.*, 2001, **109**, 59.

- 19 J. G. Riess, *J. Fluorine Chem.*, 2002, **114**, 119.
- 20 J. G. Riess, *Tetrahedron*, 2002, **58**, 4113.
- 21 B. K. Park, N. R. Kitteringham, and P. M. O'Neill, *Annu. Rev. Pharmacol. Toxicol.*, 2001, **41**, 443.
- 22 C. Ford, *Chem. in Britain*, 2001, **37**, 22.
- 23 P. M. O'Neill, R. C. Storr, and B. K. Park, *Tetrahedron*, 1998, **54**, 4615.
- 24 R. E. Krebs, 'The History And Use Of Our Earths Chemical Elements: a reference guide', Greenwood Press, 1998.
- 25 A. J. Rudge, 'Fluorine: Manufacture and Uses.', Oxford University Press, 1962.
- 26 J. H. Simons, 'Fluorine Chemistry', Academic Press, 1958.
- 27 W. C. Schumb, R. C. Young, and K. J. Radimer, *Ind. Eng. Chem.*, 1947, **39**, 244.
- 28 J. T. Pinkston, *Ind. Eng. Chem.*, 1947, **39**, 255.
- 29 R. L. Murray, S. G. Osborne, and M. S. Kircher, *Ind. Eng. Chem.*, 1947, **39**, 249.
- 30 J. F. Gall and H. C. Miller, *Ind. Eng. Chem.*, 1947, **39**, 262.
- 31 R. D. Fowler, W. B. Burford, H. C. Anderson, J. M. Hamilton, and C. E. Weber, *Ind. Eng. Chem.*, 1947, **39**, 266.
- 32 J. F. Ellis and G. F. May, *J. Fluorine Chem.*, 1986, **33**, 133.
- 33 M. J. Stephenson, W. Golliher, and P. Haas, in 'Thermal Process for the Conversion of Uranium Hexafluoride', WO 9745371 A1, 1997.
- 34 D. Hage and D. C. Merkel, in 'Process to Produce Commercial Grade Anhydrous Hydrogen Fluoride (AHF) and Uranium Oxide from the Defluorination of Uranium Hexafluoride (UF₆)', WO 9746483 A1, 1997.
- 35 H. Goldwhite, *J. Fluorine Chem.*, 1986, **33**, 109.
- 36 A. A. Kolmakov, V. N. Bezmelnitsyn, and A. V. Bezmelnitsyn, *J. Fluorine Chem.*, 1996, **77**, 9.
- 37 T. E. Mallouk, C. M. Wang, Q.-C. Mir, and S. Malekina, *J. Am. Chem. Soc.*, 1988, **110**, 3710.
- 38 D. J. Gardiner, *J. Fluorine Chem.*, 1973/74, **3**, 226.

- 39 A. G. Streng, *Chem. Rev.*, 1963, **63**, 607.
- 40 K. O. Christe, *Inorg. Chem.*, 1986, **25**, 3721.
- 41 K. O. Christe, C. J. Schack, and R. D. Wilson, in 'Self-Clinkering NF₄⁺ Compositions for NF₃-F₂ Gas Generators and Method of Producing Same', US 4172884, 1979.
- 42 K. O. Christe, in 'Pure Fluorine Gas Generation', US 4711680, 1987.
- 43 D. Pilipovich, in 'Oxidiser Compatible Solid Propellant Fluorine Atom Gas Generator', US 3963542, 1976.
- 44 M. J. Orlett and A. J. Saraceno, in 'Method for Directly Recovering Fluorine from Gas Streams', US 4292287, 1981.
- 45 L. W. Wakefield and B. J. Whyte, in 'Process for the Production of Active Fluorine and Intermediates Involved in Active Fluorine Production and Uses of this Active Fluorine', WO 9827006 A1, 1998.
- 46 R. N. Compton, R. L. Hettich, A. A. Tuinman, P. Mukherjee, and J. L. Adcock, *J. Phys. Chem.*, 1992, **96**, 7584.
- 47 S. D. Taylor, C. C. Kotoris, and G. Hum, *Tetrahedron*, 1999, **55**, 12431.
- 48 S. Rozen, *Chem. Rev.*, 1996, **96**, 1717.
- 49 J. A. Wilkinson, *Chem. Rev.*, 1992, **92**, 505.
- 50 G. P. Pez, G. S. Lal, and R. G. Syvret, *Chem. Rev.*, 1996, **96**, 1737.
- 51 R. E. Banks and J. C. Tatlow, *J. Fluorine Chem.*, 1986, **33**, 227.
- 52 F. G. Drakesmith, *Topp. Curr. Chem.*, 1997, **193**, 197.
- 53 P. Sartori and N. Ignat'ev, *J. Fluorine Chem.*, 1998, **87**, 157.
- 54 R. E. Banks, B. E. Smart, and J. C. Tatlow, 'Organofluorine Chemistry: Principles and Commercial Applications', Plenum Press, 1994.
- 55 J. M. Tedder, *Adv. Fluorine Chem.*, 1961, **2**, 104.
- 56 R. J. Lagow and J. L. Margrave, *Prog. Inorg. Chem.*, 1979, **26**, 161.
- 57 W. T. Miller and A. L. Dittman, *J. Am. Chem. Soc.*, 1956, **78**, 2793.

- 58 W. T. Miller, S. D. Koch, and F. W. McLafferty, *J. Am. Chem. Soc.*, 1956, **78**, 4992.
- 59 W. T. Miller and S. D. Koch, *J. Am. Chem. Soc.*, 1957, **79**, 3084.
- 60 M. Cartwright and A. A. Woolf, *J. Fluorine Chem.*, 1981, **19**, 101.
- 61 M. M. Cartwright and A. A. Woolf, *J. Fluorine Chem.*, 1984, **25**, 263.
- 62 K. O. Christe, *J. Fluorine Chem.*, 1983, **22**, 519.
- 63 K. O. Christe, *J. Fluorine Chem.*, 1984, **25**, 269.
- 64 G. A. Olah and L. Heiliger, *J. Am. Chem. Soc.*, 1990, **112**, 3920.
- 65 G. Sandford. and J. Hutchinson, *Top. Curr. Chem.*, 1997, **193**, 1.
- 66 G. Cotti, S. A. Cooke, C. M. Evans, J. H. Holloway, and A. C. Legon, *Chem. Phys. Lett.*, 1996, **260**, 388.
- 67 A. C. Legon, *Chem. Commun.*, 1998, 2737.
- 68 S. Fornarini, R. Cipollini, and M. Elisa, *J. Am. Chem. Soc.*, 1997, **119**, 9499.
- 69 S. Fornarini, B. Chiavario, and M. E. Crestoni, *Adv. Mass Spectro.*, 1998, **14**, A01 MOPO010.
- 70 P. Kollman and S. Rothenburg, *J. Am. Chem. Soc.*, 1977, **99**, 1333.
- 71 J. E. D. Bene, M. J. Frisch, K. Raghavacharl, and J. A. Pople, *J. Phys. Chem.*, 1982, **86**, 1529.
- 72 R. L. Dekock, A. Rauk, R. Dutler, and R. D. van Zee, *Inorg. Chem.*, 1986, **25**, 3329.
- 73 G. A. Olah, Y. Li, X. Wang, F. Jensen, and K. N. Houk, *J. Am. Chem. Soc.*, 1990, **112**, 3922.
- 74 I. Frank and D. Aktah, *J. Am. Chem. Soc.*, 2002, **124**, 3402.
- 75 C.-H. Wong, S. P. Vincent, M. D. Burkart, C.-Y. Tsai, and Z. Zhang, *J. Org. Chem.*, 1999, **64**, 5264.
- 76 G. S. Lal and G. Pez, *Abstr. Pap. Am. Chem. Soc.*, 2000, **220**, 290.
- 77 R. D. Chambers, C. J. Skinner, J. Hutchinson, and J. Thomson, *J. Chem. Soc., Perkin Trans. 1*, 1996, 605.

- 78 S. T. Purrington, B. S. Kagen, and T. B. Patrick, *Chem. Rev.*, 1986, **86**, 997.
- 79 S. Rozen, *Acc. Chem. Res.*, 1996, **29**, 243.
- 80 L. A. Bigelow, *Chem. Rev.*, 1947, **40**, 51.
- 81 R. D. Chambers, J. Hutchinson, M. E. Sparrowhawk, G. Sandford, J. S. Moilliet, and J. Thomson, *J. Fluorine Chem.*, 2000, **102**, 169.
- 82 J. S. Moilliet, *J. Fluorine Chem.*, 2001, **109**, 13.
- 83 J. R. Barrio, N. Satyamurthy, M. Namavari, and M. E. Phelps, in 'Process for Producing 8-Fluoropurines', US 5861503, 1999.
- 84 J. S. Moilliet, in 'Fluorination of Carbonyl-Substituted Aromatic Compounds', WO 9824740 A1, 1998.
- 85 C. J. Skinner, J. Hutchinson, J. Thompson, and R. D. Chambers, in 'Fluorination Process', US 5900502, 1999.
- 86 S. Pasenok and W. Appel, in 'Process for Preparing Fluorinated Aromatics', US 5756834, 1998.
- 87 S. Pasenok and W. Appel, in 'Verfahren zur Herstellung von Fluorierten Aromaten', EP 773210 A1, 1997.
- 88 R. D. Bowden and J. S. Moilliet, in 'Fluorination Method', WO 0179143 A1, 2001.
- 89 R. Chirakal, N. Vasdev, G. J. Schrobilgen, and C. Nahmias, *J. Fluorine Chem.*, 1999, **99**, 87.
- 90 R. Chirakal, N. Vasdev, G. J. Schrobilgen, and C. Nahmias, *J. Fluorine Chem.*, 2001, **111**, 17.
- 91 R. D. Chambers and C. J. Skinner, in 'Preparation of Nitrofluoroaromatic Compounds', GB 2291871 A, 1996.
- 92 P. L. Coe, A. M. Stuart, and D. J. Moody, *J. Chem. Soc., Perkin Trans. 1*, 1998, 1807.
- 93 A. M. Stuart, P. L. Coe, and D. J. Moody, *J. Fluorine Chem.*, 1998, **88**, 179.
- 94 M. P. Greenhall, A. K. Joel, and J. S. Moilliet, in 'Fluorination Method', WO 0222525 A1, 2002.

- 95 N. S. Chilingarov, A. V. Nikitin, J. V. Rau, I. V. Golyshevsky, A. V. Kepman, F. M. Spiridonov, and L. N. Sidorov, *J. Fluorine Chem.*, 2002, **113**, 219.
- 96 H. Touhara, J. Inahara, T. Mizuno, Y. Yokoyama, S. Okanao, K. Yanagiuchi, I. Mukopadhyay, S. Kawasaki, F. Okino, H. Shirai, W. H. Xu, T. Kyotani, and A. Tomita, *J. Fluorine Chem.*, 2002, **114**, 181.
- 97 R. D. Chambers, C. J. Skinner, M. J. Atherton, and J. S. Moilliet, *J. Chem. Soc., Perkin Trans. I*, 1996, 1659.
- 98 R. D. Chambers, C. J. Skinner, M. J. Atherton, and J. S. Moilliet, in 'Halogenation Reactions', WO 9603356 A1, 1996.
- 99 J. R. Barrio, M. Namavari, P. M. E, and N. Satyamurthy, *J. Am. Chem. Soc.*, 1996, **118**, 10408.
- 100 J. R. Barrio, M. Namavari, M. E. Phelps, and N. Satyamurthy, *J. Org. Chem.*, 1996, **61**, 6084.
- 101 J. R. Barrio, N. Satyamurthy, M. Namavari, and M. E. Phelps, in '8-Fluoropurine Compounds', US 6262254 B1, 2001.
- 102 R. D. Chambers, M. Parsons, G. Sandford, and R. Bowden, *Chem. Commun.*, 2000, 959.
- 103 R. D. Chambers and D. J. Goddard, in 'Preparation of Selectively Fluorinated Organic Compounds', WO 0128959 A1, 2001.
- 104 R. D. Chambers, P. Parsons, and G. Sandford, in 'Selective Nitrogen Functionalisation of Organic Compounds', WO 0153234 A1, 2001.
- 105 G. V. Lagodzinskaya, L. T. Eremenko, and G. V. Oreshko, *Spectrochim. Acta Part A*, 2001, **57**, 1663.
- 106 R. D. Chambers, M. P. Greenhall, and J. Hutchinson, *Tetrahedron*, 1996, **52**, 1.
- 107 R. D. Chambers, J. Hutchinson, M. P. Greenhall, J. S. Moilliet, and J. Thomson, in 'Preparation of Fluorinated Dicarbonyls', US 6020502, 2000.
- 108 R. D. Chambers, J. Hutchinson, and J. Thomson, *J. Fluorine Chem.*, 1996, **78**, 165.

- 109 R. D. Chambers, J. Hutchinson, and J. Thomson, in 'A Process for the Preparation of Esters', WO 9700848 A1, 1997.
- 110 R. D. Chambers, J. Hutchinson, and J. Thomson, in 'Process for the Preparation of Esters', US 5847198, 1998.
- 111 S. Ishihara and K. Adachi, in 'Process for the Production of Fluorodicarbonyl Compounds', WO 0130740 A1, 2001.
- 112 W. J. Casteel and W. H. Bailey, in 'Direct Fluorination Process for Preparing High Purity Alpha-Fluoro-Beta-Dicarbonyl Compounds', EP 1095928 A2, 2001.
- 113 T. Umemoto and G. Tomizawa, in 'Process for Preparing Fluorine-Containing Dicarbonyl Compound', US 5569778, 1996.
- 114 T. Umemoto and G. Tomizawa, in 'Process for Preparing Fluorine-Containing Dicarbonyl Compound', EP 781752 A1, 1997.
- 115 K. Nuki, S. Fukami, and K. Kawada, in 'Process for the Preparation of Fluorinated Dicarbonyl Compounds', WO 9735824 A1, 1997.
- 116 R. D. Chambers and J. Hutchinson, in 'Preparation of Fluorinated Compounds', WO 9905080 A1, 1999.
- 117 R. D. Chambers, J. Hutchinson, A. S. Bastanov, C. W. Lehmann, and D. Naumov, *J. Chem. Soc., Perkin Trans. 1*, 1996, 2271.
- 118 M. Sato, C. Kaneko, and H. Kamaya, *Tetrahedron Lett.*, 1997, **38**, 587.
- 119 R. D. Chambers and J. Hutchinson, *J. Fluorine Chem.*, 1998, **89**, 229.
- 120 J. Hutchinson and R. D. Chambers, in 'Preparation of Alpha-Fluoroketones', WO 9746508 A1, 1997.
- 121 J. Hutchinson and R. Chambers, in 'Preparation of alpha fluoroketones', US 6031139, 2000.
- 122 R. D. Chambers, J. Hutchinson, and J. Thomson, in 'Fluorination of Ketoamides', WO 9805628 A1, 1998.
- 123 R. D. Chambers and J. Hutchinson, *J. Fluorine Chem.*, 1998, **92**, 45.
- 124 R. D. Chambers, J. Hutchinson, and J. S. Moilliet, in 'Catalysed Fluorination of Carbonyl Compounds', WO 9903802 A1, 1999.

- 125 A. Toyota, M. Uchiyama, and C. Kaneko, *Tetrahedron*, 1997, **53**, 6327.
- 126 R. D. Chambers, W. K. Gray, G. Sandford, and J. F. S. Vaughan, *J. Fluorine Chem.*, 1999, **94**, 213.
- 127 A. E. Feiring, S. Rozen, and E. R. Wonchoba, *J. Fluorine Chem.*, 1998, **89**, 31.
- 128 D. D. Moldavskii, T. A. Bispen, G. I. Kaurova, and G. G. Furin, *J. Fluorine Chem.*, 1999, **94**, 157.
- 129 F. Prati, A. Forni, I. Moretti, G. Torre, V. V. Rozhkov, K. N. Makarov, I. I. Chervin, and R. G. Kostyanovsky, *J. Fluorine Chem.*, 1998, **89**, 177.
- 130 R. G. Syvret, R. E. Banks, V. Murtagh, and H. M. Marsden, *J. Fluorine Chem.*, 2001, **112**, 271.
- 131 R. E. Banks, M. K. Besheesh, S. N. Mohialdin-Khaffaf, and I. Sharif, *J. Fluorine Chem.*, 1997, **81**, 157.
- 132 A. J. Poss and G. A. Shia, *Tetrahedron Lett.*, 1999, **40**, 2673.
- 133 T. Umemoto and M. Nagayoshi, *Bull. Chem. Soc. Jpn.*, 1996, **69**, 2287.
- 134 R. E. Banks, *J. Fluorine Chem.*, 1996, **78**, 39.
- 135 R. E. Banks, M. K. Besheesh, N. J. Lawrence, and D. J. Tovell, *J. Fluorine Chem.*, 1999, **97**, 79.
- 136 T. Umemoto, M. Nagayoshi, K. Adachi, and G. Tomizawa, *J. Org. Chem.*, 1998, **63**, 3379.
- 137 Y. Takeuchi, A. Satoh, T. Suzuki, A. Kameda, M. Dohrin, T. Satoh, T. Koizumi, and K. L. Kirk, *Chem. Pharm. Bull.*, 1997, **45**, 1085.
- 138 F. A. Davis, P. Zhou, C. K. Murphy, G. Sundarababu, H. Qi, W. Han, R. M. Przeslawski, B.-C. Chen, and P. J. Carroll, *J. Org. Chem.*, 1998, **63**, 2273.
- 139 S. Rozen, *Pure Appl. Chem.*, 1999, **71**, 481.
- 140 S. Rozen, S. Dayan, and Y. Bareket, *Tetrahedron*, 1999, **49**, 3657.
- 141 R. D. Chambers, J. Hutchinson, G. Sandford, A. Shah, and J. F. S. Vaughan, *Tetrahedron*, 1997, **53**, 15833.
- 142 R. D. Chambers and G. Sandford, in 'The Preparation of Organic Compounds', WO 9604229 A1, 1996.

- 143 R. D. Bowden, M. P. Greenhall, J. S. Moilliet, and J. Thomson, in 'The Preparation of Fluorinated Organic Compounds', WO 9705106 A1, 1997.
- 144 D. Philp, R. D. Bowden, P. J. Comina, M. P. Greenhall, B. M. Kariuki, and A. Loveday, *Tetrahedron*, 2000, **56**, 3399.
- 145 T. M. Klapotke and M.-J. Crawford, *J. Fluorine Chem.*, 1998, **92**, 153.
- 146 A. Toyota, Y. Ono, C. Kaneko, and I. Hayakawa, *Tetrahedron Lett.*, 1996, **37**, 8507.
- 147 R. D. Chambers, G. Sandford, M. E. Sparrowhawk, and M. J. Atherton, *J. Chem. Soc., Perkin Trans. 1*, 1996, 1941.
- 148 R. D. Chambers and G. Sandford, in 'Selectively Fluorinated Organic Compounds', WO 9603357 A1, 1996.
- 149 R. D. Chambers and G. Sandford, in 'Selectively Fluorinated Organic Compounds', US 5789580, 1998.
- 150 A. Sekiya, H.-D. Quan, M. Tamura, J. Murata, and R.-X. Gao, *J. Fluorine Chem.*, 2000, **106**, 121.
- 151 M. Ue, Y. Sasaki, R. Ebara, N. Nanbu, and M. Takehara, *J. Fluorine Chem.*, 2001, **108**, 117.
- 152 R. J. Lagow, H.-C. Wei, and S. Corbelin, *J. Org. Chem.*, 1996, **61**, 1643.
- 153 R. D. Chambers, A. K. Joel, and A. J. Rees, *J. Fluorine Chem.*, 2000, **101**, 97.
- 154 R. J. Lagow and H.-C. Wei, *Chem. Commun.*, 2000, 2139.
- 155 R. J. Lagow, H.-C. Wei, and V. M. Lynch, *J. Org. Chem.*, 1997, **62**, 1527.
- 156 J. L. Adcock and H. Zhang, *J. Org. Chem.*, 1996, **61**, 1975.
- 157 R. J. Lagow, T.-Y. Lin, and H.-C. Chang, *J. Org. Chem.*, 1999, **64**, 8127.
- 158 T. Okazoe, K. Watanabe, M. Itoh, D. Shirakawa, and S. Tatematsu, *J. Fluorine Chem.*, 2001, **112**, 109.
- 159 D. S. Pashkevich, D. A. Muhortov, E. A. Podpalkina, and V. G. Barabanov, *J. Fluorine Chem.*, 1999, **96**, 3.
- 160 D. S. Pashkevich, D. A. Mukhortov, Y. I. Alekseev, V. S. Asovich, and O. V. Rozhdestvenskaya, *Russ. J. Applied Chem. (Engl. Transl.)*, 2001, **74**, 1151.

- 161 R. E. Banks and J. C. Tatlow, *J. Fluorine Chem.*, 1986, **33**, 198.
- 162 M. B. Smith and J. March, 'March's Advanced Organic Chemistry Reactions, Mechanisms, and Structure.', John Wiley and Sons, Inc., 2001.
- 163 V. Grakauskas, *Intra.-Sci. Chem. Reports*, 1971, **5**, 85.
- 164 R. D. Chambers and R. C. H. Spink, *Chem. Commun.*, 1999, 883.
- 165 R. D. Chambers, D. Holling, R. C. H. Spink, and G. Sandford, *Lab on a Chip*, 2001, **1**, 132.
- 166 V. Hessel, W. Ehrfeld, K. Golbig, V. Haverkamp, H. Lowe, M. Storz, and C. Wille, *Microreaction Technology Industrial Prospects. IMRET 3: Proceedings of the Third International Conference on Microreaction Technology*, Berlin, 2000, p. 526.
- 167 N. de Mas, R. J. Jackman, M. A. Schmidt, and K. F. Jensen, *Microreaction Technology. IMRET 5: Proceedings of the Fifth International Conference on Microreaction Technology*, Strasbourg, 2001, p. 60.
- 168 A. E. Guber and W. Bacher, *Microreaction Technology Industrial Prospects. IMRET 3: Proceedings of the Third International Conference on Microreaction Technology*, Berlin, 2000, p. 617.
- 169 K. Jahnisch, V. Hessel, M. Baerns, W. Ehrfeld, V. Haverkamp, H. Lowe, C. Wille, and A. Guber, *J. Fluorine Chem.*, 2000, **105**, 117.
- 170 P. Harston, M. J. Atherton, R. G. Holmes, R. D. Chambers, and R. Spink, in 'A Method of Performing a Chemical Reaction', WO 9922857 A1, 1999.
- 171 H. Schuppich, K. Golbig, and B. Dittmann, in 'Micro-Reactor for Reactions Between Gases and Liquids', WO 0209866 A2, 2002.
- 172 K. V. Scherer, K. Yamanouchi, and T. Ono, *J. Fluorine Chem.*, 1990, **50**, 47.
- 173 L. A. Bigelow and D. S. Young, *J. Am. Chem. Soc.*, 1940, **62**, 1171.
- 174 L. A. Bigelow and A. R. Gilbert, *J. Am. Chem. Soc.*, 1950, **72**, 2411.
- 175 L. A. Bigelow and E. A. Tyczkowski, *J. Am. Chem. Soc.*, 1953, **75**, 3523.
- 176 W. K. R. Musgrave and F. Smith, *J. Chem. Soc.*, 1949, 3026.
- 177 L. A. Bigelow and E. A. Tyczkowski, *J. Am. Chem. Soc.*, 1955, **77**, 3007.

- 178 L. A. Bigelow, A. F. Maxwell, and F. E. Detoro, *J. Am. Chem. Soc.*, 1960, **82**, 5827.
- 179 R. J. Lagow and R. E. Aikman, *J. Org. Chem.*, 1982, **47**, 2789.
- 180 J. L. Adcock, K. Horita, and E. B. Renk, *J. Am. Chem. Soc.*, 1981, **103**, 6937.
- 181 S. Rozen, O. Lerman, Y. Tor, and D. Hebel, *J. Org. Chem.*, 1984, **49**, 806.
- 182 H. Gershon, M. W. McNeil, R. Parmegiani, and P. K. Godfrey, *J. Med. Chem.*, 1972, **15**, 987.
- 183 S. P. Anand and R. Filler, *J. Fluorine Chem.*, 1976, **7**, 179.
- 184 A. Roe and G. F. Hawkins, *J. Am. Chem. Soc.*, 1949, **71**, 1785.
- 185 K.-I. Saeki, A. Hakura, H. Kawai, and Y. Kawazoe, *Biol. Pharm. Bull.*, 1997, **20**, 646.
- 186 K.-I. Saeki, T.-A. Kato, Y. Kawazoe, and A. Hakura, *Mutation Research*, 1999, **439**, 149.
- 187 A. Roe and C. E. Teague Jr, *J. Am. Chem. Soc.*, 1951, **73**, 687.
- 188 J. C. Belsten and S. F. Dyke, *J. Chem. Soc.*, 1964, 22.
- 189 M. Bellas and H. Suschitzky, *J. Chem. Soc.*, 1964, 4561.
- 190 M. Kidwai, P. Sapra, and K. R. Bhushan, *Indian J. Chem.*, 1999, **38B**, 114.
- 191 R. D. Chambers, M. Hole, W. K. R. Musgrave, and R. A. Storey, *J. Chem. Soc. (C)*, 1966, 2328.
- 192 H. Yoshioka, Y. Uchibori, and M. Umeno, *Heterocycles*, 1992, **34**, 1507.
- 193 V. D. Shteingarts and I. I. Oleynik, *J. Fluorine Chem.*, 1998, **91**, 25.
- 194 A. R. Katritzky and R. Taylor, *Adv. Heterocycl. Chem.*, 1990, **47**.
- 195 J. A. Joule and G. F. Smith, 'Heterocyclic Chemistry', Van Nostrand Company, 1978.
- 196 G. Jones, 'Quinolines: Part 1', John Wiley and Sons, Inc., 1979.
- 197 M. Gordon and D. E. Pearson, *J. Org. Chem.*, 1964, **29**, 329.

- 198 F. Dolle, M. Karramkam, H. Valette, L. Besret, Y. Bramouille, F. Hinnen, F. Vaufrey, C. Franklin, S. Bourg, C. Coulon, M. Ottaviani, M. Delaforge, C. Loch, M. Bottlaender, and C. Crouzel, *Bioorg. Med. Chem.*, 2002, **10**, 2611.
- 199 T. L. Gilchrist, 'Heterocyclic Chemistry', Longman Scientific and Technical, 1993.
- 200 Y. Kobayashi, I. Kumadaki, and T. Yamashita, *Heterocycles*, 1982, **17**, 429.
- 201 M. Sato, T. Taniguchi, T. Hirokawa, and C. Kaneko, *Tetrahedron Lett.*, 1995, **36**, 6705.
- 202 R. D. Chambers, M. Parsons, G. Sandford, C. J. Skinner, M. J. Atherton, and J. S. Moillet, *J. Chem. Soc., Perkin Trans. 1*, 1999, 803.
- 203 R. D. Chambers and G. Sandford, in 'Process for the Preparation of Fluorinated Heterocyclic Compounds', US 5859255, 1999.
- 204 R. D. Chambers and G. Sandford, in 'Process for the Preparation of Fluorinated Heterocyclic Compounds', WO 9619456 A1, 1996.
- 205 M. van der Puy, *Tetrahedron Lett.*, 1988, **29**, 4389.
- 206 L. Streckowski and A. N. Parker, *Heterocycl. Commun.*, 1998, **4**, 493.
- 207 R. D. Chambers, C. J. Skinner, and G. Sandford, in 'The Alkoxylation of Heterocyclic Compounds in the Presence of Fluorine', WO 9603379 A1, 1996.
- 208 S. Rozen, D. Hebel, and D. Zamir, *J. Am. Chem. Soc.*, 1987, **109**, 3789.
- 209 T. Umemoto and G. Tomizawa, *J. Org. Chem.*, 1989, **54**, 1726.
- 210 P. B. D. de la Mare, M. Kiamuddin, and J. H. Ridd, *Chem. Ind. (London)*, 1958, 361.
- 211 P. B. D. de la Mare, M. Kiamuddin, and J. H. Ridd, *J. Chem. Soc.*, 1960, 561.
- 212 M. Kiamuddin and A. K. Choudhury, *Chem. Ind. (London)*, 1963, 1840.
- 213 M. Kiamuddin and M. E. Haque, *Chem. Ind. (London)*, 1964, 1753.
- 214 D. Doddrell, M. Barfield, W. Adcock, M. Aurangzeb, and D. Jordan, *J. Chem. Soc., Perkin Trans. 2*, 1976, 402.
- 215 M. J. S. Dewar and J. Kelemen, *J. Chem. Phys.*, 1968, **49**, 499.

- 216 H.-O. Kalinowski, S. Berger, and S. Braun, 'Carbon-13 NMR Spectroscopy', John Wiley and Sons, 1988.
- 217 R. E. Banks and M. K. Besheesh, *J. Fluorine Chem.*, 1996, **76**, 161.
- 218 M. Zupan, J. Iskra, and S. Stavber, *Bull. Chem. Soc. Jpn*, 1995, **68**, 1655.
- 219 R. Elderfield, W. J. Gensler, T. A. Williamson, J. M. Griffing, S. M. Kupchan, J. T. Maynard, F. J. Kreysa, and J. B. Wright, *J. Am. Chem. Soc.*, 1946, **68**, 1584.
- 220 H. Auterhoff and H. J. Pankow, *Ger. Arch. Pharm. Ber. Dtsch. Pharm. Ges.*, 1967, **300**, 103.
- 221 Z. Cziaky, *Synth. Commun.*, 1991, **21**, 1929.
- 222 S. Tatsuoka, J. Ueyanagi, and T. Kinoshita, *J. Pharma. Soc. Japan*, 1949, **69**, 33.
- 223 R. C. Elderfield, H. E. Mertel, R. T. Mitch, I. M. Wempen, and E. Werble, *J. Am. Chem. Soc.*, 1955, **77**, 4816.
- 224 R. C. Elderfield, W. R. Vaughan, B. B. Millward, and J. H. Ross, *J. Org. Chem.*, 1958, **23**, 1378.
- 225 P. M. O'Neill, M. D. Tingle, R. Mahmud, R. C. Storr, S. A. Ward, and B. K. Park, *Bioorg. Med. Chem. Lett.*, 1995, **5**, 2309.
- 226 A. I. Tochilkin, I. R. Kovel'man, E. P. Prokof'ev, I. N. Gracheva, and M. V. Levinskii, *Chem. Heterocycl. Compd. (Engl. Trans.)*, 1989, **24**, 892.
- 227 W. Dmowski, *J. Fluorine Chem.*, 1982, **20**, 589.
- 228 A. I. Tochilkin, I. N. Gracheva, I. R. Kovel'man, and E. P. Prokof'ev, *Chem. Heterocycl. Compd. (Engl. Trans.)*, 1983, 1093.
- 229 I. N. Gracheva and A. I. Tochilkin, *Chem. Abstr.*, 1980, **93**, 71504y.
- 230 S. Misaki, *J. Fluorine Chem.*, 1981, **17**, 159.
- 231 C. A. Franz, R. T. Hall, and C. E. Kaslow, *Tetrahedron Lett.*, 1967, **20**, 1947.
- 232 M. Rabinovitz, I. Agranat, H. Selig, and C.-H. Lin, *J. Fluorine Chem.*, 1977, **10**, 159.
- 233 S. Rozen, O. Lerman, M. Kol, and D. Hebel, *J. Org. Chem.*, 1985, **50**, 4753.

- 234 N. D. Heindel, I. Jabin, R. D. Rapp, and J. D. Laskin, *J. Heterocycl. Chem.*, 2000, **37**, 31.
- 235 F. M. E. Abdel-Megeid, M. A. F. El-Kaschef, and A. A. G. Ghattas, *Egypt J. Chem.*, 1977, **20**, 453.
- 236 H.-J. Bertram, S. Bohm, and L. Born, *Synthesis*, 1991, 937.
- 237 J. P. Edwards, S. J. West, K. B. Marschke, D. E. Mais, M. M. Gottardis, and T. K. Jones, *J. Med. Chem.*, 1998, **41**, 303.
- 238 H. Heaney and A. P. Price, *J. Chem. Soc., Perkin Trans. I*, 1972, 2911.
- 239 M. Hudlicky, *Chem. Abstr.*, 1964, **61**, 1824f.
- 240 H.-Y. Li and G. A. Boswell, *Tetrahedron Lett.*, 1996, **37**, 1551.
- 241 W.-C. Sun, K. R. Gee, and R. P. Haugland, *Bioorg. Med. Chem. Lett.*, 1998, **8**, 3107.
- 242 M. Schlosser, Q. Wang, and G.-Q. Shi, *Tetrahedron*, 1996, **52**, 4403.
- 243 E. D. Bergmann and I. Shahak, *J. Chem. Soc.*, 1961, 4033.
- 244 V. J. Dalvi and S. Sethna, *J. Indian Chem. Soc.*, 1949, **26**, 359.
- 245 S. S. Lele and S. Sethna, *J. Org. Chem.*, 1958, **23**, 1731.
- 246 J. Jonas, *Chem. Abstr.*, 1972, **76**, 99430u.
- 247 S. Rozen and M. Brand, *J. Org. Chem.*, 1986, **51**, 3607.
- 248 A. R. Katritzky and C. W. Rees, 'Comprehensive Heterocyclic Chemistry', Pergamon Press, 1984.
- 249 A. Clayton, *J. Chem. Soc.*, 1910, 2102.
- 250 D. E. Pearson, W. E. Stamper, and B. R. Suthers, *J. Org. Chem.*, 1963, **28**, 3147.
- 251 S. A. Sojka, *J. Org. Chem.*, 1975, **40**, 1175.
- 252 I. Fleming, 'Frontier Orbitals and Organic Chemical Reactions', John Wiley and Sons, Inc., 1998.
- 253 in 'Verfahren zur Fluorierung Organischer Verbindungen durch Verwendung von Fluor', DE 651049, 1937.
- 254 T. N. Huckerby, *J. Mol. Struct.*, 1979, **54**, 289.

- 255 C. A. Heaton, 'An Introduction to Industrial Chemistry', Leonard Hill, 1984.
- 256 M. D. Wynne, 'Chemical Processing in Industry', Royal Institute of Chemistry, 1970.
- 257 D. G. Jones, 'Chemistry and Industry', Clarendon Press, 1967.
- 258 J. J. Lerou and K. M. Ng, *Chem. Eng. Sci.*, 1996, **51**, 1595.
- 259 A. Green, *Chem. Ind.*, 1998, 168.
- 260 A. R. Oroskar, K. M. van den Bussche, and S. F. Abdo, Microreaction Technology. IMRET 5: Proceedings of the Fifth International Conference on Microreaction Technology, Strasbourg, 2001, p. 153.
- 261 R. S. Wegeng, M. K. Drost, and D. L. Brenchley, Microreaction Technology Industrial Prospects. IMRET 3: Proceedings of the Third International Conference on Microreaction Technology, Berlin, 2000, p. 2.
- 262 A. M. Rouhi, *Chem. Eng. News*, 2002, **March 4**, 36.
- 263 W. Ehrfeld, V. Hessel, and H. Lowe, 'Microreactors', Wiley-VCH, 2000.
- 264 G. Weickert, G. B. Meier, J. T. M. Pater, and K. R. Westerterp, *Chem. Eng. Sci.*, 1999, **54**, 3291.
- 265 S. J. Haswell, P. D. I. Fletcher, E. Pombo-Villar, B. H. Warrington, P. Watts, S. Y. F. Wong, and X. Zhang, *Tetrahedron*, 2002, **58**, 4735.
- 266 T. McCreedy, *Chem. Ind.*, 1999, 588.
- 267 H. Lowe and W. Ehrfeld, *Electrochimica Acta*, 1999, **44**, 3679.
- 268 V. Hessel, W. Ehrfeld, K. Golbig, C. Hofmann, S. Jungwirth, H. Lowe, T. Richter, M. Storz, and A. Wolf, Microreaction Technology Industrial Prospects. IMRET 3: Proceedings of the Third International Conference on Microreaction Technology, Berlin, 2000, p. 151.
- 269 H. Kestenbaum, A. Lange de Oliveira, W. Schmidt, F. Schuth, W. Ehrfeld, K. Gebauer, H. Lowe, and T. Richter, Microreaction Technology Industrial Prospects. IMRET 3: Proceedings of the Third International Conference on Microreaction Technology, Berlin, 2000, p. 207.

- 270 D. L. Brenchley, *Microreaction Technology. IMRET 5: Proceedings of the Fifth International Conference on Microreaction Technology*, Strasbourg, 2001, p. 343.
- 271 H. Krummradt, U. Koop, and J. Stoldt, *Microreaction Technology Industrial Prospects. IMRET 3: Proceedings of the Third International Conference on Microreaction Technology*, Berlin, 2000, p. 181.
- 272 'Corrosion Resistance of Nickel-Containing Alloys in Organic Acids and Related Compounds', The International Nickel Company Inc, 1979.
- 273 A. Gavriilidis, P. Angeli, E. Cao, K. K. Yeong, and Y. S. S. Wan, *Trans. IChemE*, 2002, **80**, 3.
- 274 G. F. Hewitt and N. S. Hall-Taylor, 'Annular Two Phase Flow', Pergamon Press L.T.D., 1970.
- 275 R. L. Timings, 'Manufacturing Technology', Longman Scientific and Technical, 1994.
- 276 C. McMahon and J. Browne, 'CAD/CAM: Principles, Practice and Manufacture', Addison-Wesley, 1998.
- 277 E. M. Trent, 'Metal Cutting', Butterworth, Heinemann, 1991.
- 278 W. Ehrfeld and U. Ehrfeld, *Microreaction Technology. IMRET 5: Proceedings of the Fifth International Conference on Microreaction Technology*, Strasbourg, 2001, p. 3.
- 279 A. J. Lissaman and S. J. Martin, 'Principles of Engineering Production', Hodder and Stoughton, 1982.
- 280 T. McCreedy, *Trends in Analytical Chemistry*, 2000, **19**, 396.
- 281 M. U. Kopp, H. J. Crabtree, and A. Manz, *Current Opinion in Chemical Biology*, 1997, **1**, 410.
- 282 J. Powell, 'CO₂ Laser Cutting', Springer-Verlag, 1993.
- 283 E. Bremus, A. Gillner, D. Hellrung, H. Hocker, F. Legewie, R. Poprawe, M. Wehner, and M. Wild, *Microreaction Technology Industrial Prospects. IMRET 3: Proceedings of the Third International Conference on Microreaction Technology*, Berlin, 2000, p. 80.

- 284 A. de Mello and R. Wootton, *Lab on a Chip*, 2002, **2**, 7N.
- 285 S. J. Haswell, R. J. Middleton, B. O'Sullivan, V. Skelton, P. Watts, and P. Styring, *Chem. Commun.*, 2001, 391.
- 286 H. Maeda, K. Kusakabe, and S. Morooka, *Korean J. Chem. Eng.*, 2001, **18**, 271.
- 287 S. J. Haswell and V. Skelton, *Trends in Analytical Chemistry*, 2000, **19**, 389.
- 288 K. F. Jensen, *AIChE Journal*, 1999, **45**, 2051.
- 289 K. Fabian, J. Stoldt, H. Wurziger, and N. Schwesinger, in 'Die Folgenden Angaben Sind Den Vom Anmelder Eingereichten Unterlagen Entnommen', DE 19946367 A1, 2001.
- 290 D. Wehle, M. Dejmek, J. Rosenthal, H. Ernst, D. Kampmann, S. Trautschold, and R. Pechatschek, in 'Method for Selective Chlorination in Microreactors', WO 0210094 A1, 2002.
- 291 P. M. Martin, D. W. Matson, and W. D. Bennett, *Chem. Eng. Commun.*, 1999, **173**, 245.
- 292 H. Leidheiser, 'The Corrosion of Copper, Tin, and their Alloys', John Wiley and Sons, Inc., 1971.
- 293 H. H. Uhlig, 'Corrosion and Corrosion Control', John Wiley and Sons, Inc., 1971.
- 294 G. P. Gambaretto, L. Conte, M. Napoli, E. Legnaro, and F. M. Carlini, *J. Fluorine Chem.*, 1993, **60**, 19.
- 295 M. Napoli, L. Conte, G. P. Gambaretto, C. Fraccaro, and E. Legnaro, *J. Fluorine Chem.*, 1995, **70**, 175.
- 296 V. Grakauskas, *J. Org. Chem.*, 1970, **35**, 723.

Compact Disc Disclaimer

While great care has been employed to avoid the presence of viral and other malicious programming on this compact disc, the author accepts no liability for loss or damage caused to computer systems by using this disc however caused. The thesis material, accept where referenced, remains the copyright of the author and transfer or storage by any means without prior consent of the author is prohibited. By using the compact disc the user hereby agrees to these terms.

