

# LSE Research Online



Discussion paper

---

## Human hand-walkers : five siblings who never stood up

Nicholas Humphrey; John R. Skoyles and Roger Keynes

LSE has developed LSE Research Online so that users may access research output of the School. Copyright © and Moral Rights for the papers on this site are retained by the individual authors and/or other copyright owners. Users may download and/or print one copy of any article(s) in LSE Research Online to facilitate their private study or for non-commercial research. You may not engage in further distribution of the material or use it for any profit-making activities or any commercial gain. You may freely distribute the URL (<http://eprints.lse.ac.uk>) of the LSE Research Online website.

**Cite this version:**

Humphrey, N.; Skoyles, J.R. & Keynes, R. (2005). *Human hand-walkers : five siblings who never stood up* [online]. London: LSE Research Online.

Available at: <http://eprints.lse.ac.uk/archive/00000463>

This is a copy of a discussion paper produced by the Centre for Philosophy of Natural and Social Science, CPNSS © 2005 London School of Economics and Political Science.

<http://www.lse.ac.uk/collections/CPNSS/>

<http://eprints.lse.ac.uk>

Contact LSE Research Online at: [Library.Researchonline@lse.ac.uk](mailto:Library.Researchonline@lse.ac.uk)

# Centre for Philosophy of Natural and Social Science

## Discussion Paper Series

DP 77/05

Human Hand-Walkers: Five Siblings Who Never Stood Up

Nicholas Humphrey, John R. Skoyles  
LSE

Roger Keynes  
University of Cambridge

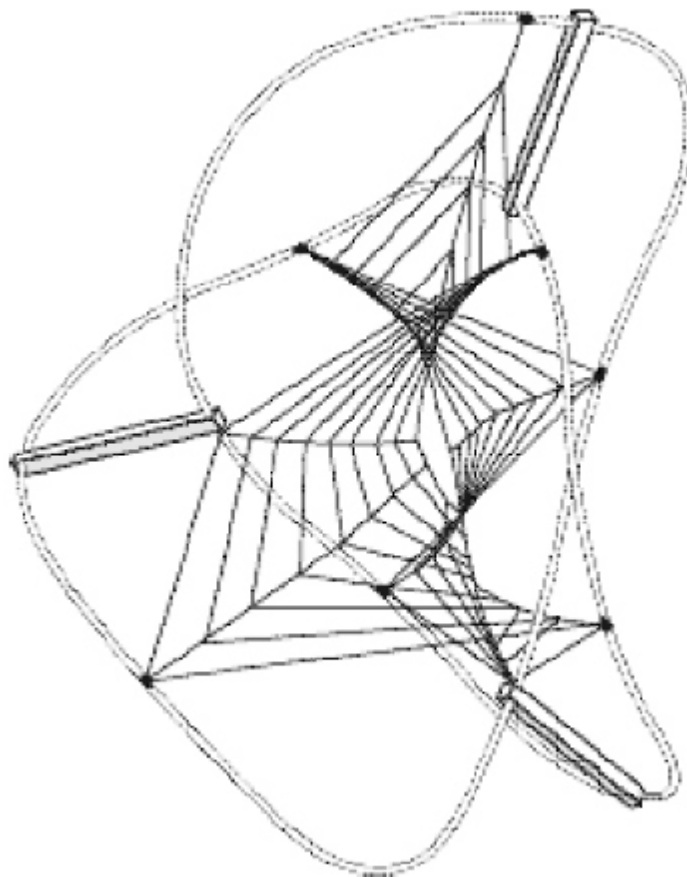

Editor: Max Steuer

## **Human Hand-Walkers: Five Siblings Who Never Stood Up**

Nicholas Humphrey<sup>1</sup>, John R. Skoyles<sup>2</sup>, & Roger Keynes<sup>3</sup>

<sup>1,2</sup> Centre for Philosophy of Natural and Social Science, London School of Economics,  
London WC2 2AE, UK

<sup>3</sup> Department of Anatomy, University of Cambridge, Downing Street, Cambridge CB2 3DY,  
UK

Paper presented at the LSE “Darwin Work in Progress Group”, 3<sup>rd</sup> October 2005.

## **Abstract**

Human beings begin life as quadrupeds, crawling on all fours, but none has ever been known to retain this gait and develop it into a proficient replacement for adult bipedality. We report the case of a family in which five siblings, who suffer from a rare form of cerebellar ataxia, are still quadrupeds as adults - walking and running on their feet and wrists. We describe the remarkable features of this gait, discuss how it has developed in the members of this family, and consider whether a similar gait may have been used by human ancestors.

## **1. Introduction**

At about one year old, human infants typically take a step that distinguishes them from – and raises them above – all other primates. Driven by psycho-neurological imperatives that have yet to be explained, they abandon the safety of crawling on all fours and lift themselves onto their back legs<sup>1</sup>. Thereafter they never revert to the ancestral quadrupedal gait.

We report here the case of five children, of a single large family, who did not make this transition and who as adults have continued to walk – highly effectively – on hands and feet. Their gait appears to be a development of the “bear crawl” which they adopted as infants, and which sometimes occurs as a transitional stage on the way to bipedality in normal infants. But it is highly unusual for this gait to persist beyond the first three or four years. Moreover the gait they show as adults has novel and – so far as we know – unprecedented features. Of particular note, the hands are placed palm-down, with all the forward weight being taken on the wrists. Such “wrist walking”, as we shall call it, is not seen in normal infants. It is quite different from the knuckle-walking of the great apes. Whether human ancestors ever walked like this is open to debate.

All five of the quadruped siblings – and also one of their biped brothers – have a congenital condition of under-development of the cerebellum, which has resulted in a nonprogressive ataxia<sup>2</sup>, suggestive of the rare condition of Disequilibrium Syndrome<sup>3</sup>. However this condition cannot provide a sufficient explanation for the quadrupedality. In general human beings with cerebellar ataxia, even if they have difficulty with balance and coordination, learn to walk bipedally, albeit with an unsteady rolling gait (as indeed the affected brother has done). But, if the ataxia is so severe as to prevent bipedalism, then it also rules out effective quadrupedalism. Quadruped animals, such as cats and dogs, with cerebellar hypoplasia are typically wobbly<sup>4</sup>. These quadruped humans, however, are well balanced.

We first describe these individuals and the characteristics of their gait, next we consider the reasons that may have been responsible for this remarkable development, and lastly we discuss the implications for theories about human evolution.

## 2. Description

The five affected siblings belong to a family of nineteen children who live in a village in Southern Turkey. Their existence was well known in their neighbourhood, and they had several times been the subject of news reports in the local media. Who else may have visited them for research purposes is unclear, but Osman Demirhan and Uner Tan (both of the Faculty of Medicine, University of Cukurova, Adana) began genetic and neurological studies in 2004. Tan contacted NH and JS, and together we visited the family in June 2005.

The genealogy of the family is shown in Fig 1. Of sixteen surviving children, ten are unaffected and walk in a normal biped way, five (four females, one male, aged now from 19 to 35) walk quadrupedally, and one (male, age 33) has cerebellar symptoms but walks upright. Another male child also walked quadrupedally but died aged 5.

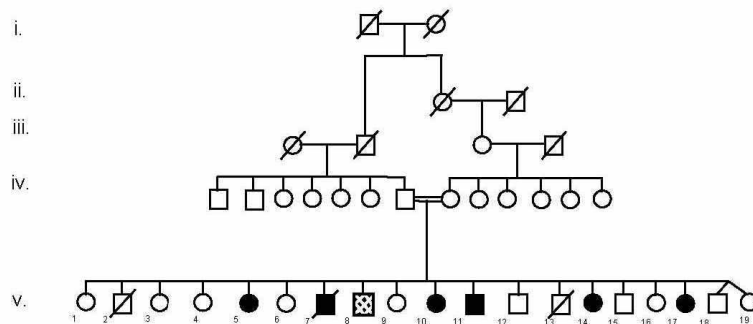

Figure 1

Pedigree of the affected subjects and their unaffected siblings. Squares represent males, and circles females. A slash line indicates the individual is deceased. The eldest quadruped, sibling #5, was born in 1969, the youngest, #17, in 1986. Black circles and squares represent subjects with cerebellar ataxia who walk quadrupedally. The hatched square represents the brother with cerebellar ataxia who walks bipedally

DNA analysis has not yet been completed and will be published separately (Demirhan and Mundlos, in preparation). However the pattern of inheritance strongly suggests that the

abnormal brain development is the result of an autosomal recessive mutant gene, presumably present in both parents, and combined homozygously in a proportion of the children (expected 25%, observed 37%). (We note that Dysequilibrium Syndrome, in the Hutterite population of the USA, has been shown to be just such an autosomal recessive disorder<sup>5</sup>.)

Behavioural observations were made at their home and farmyard, and in a hospital. (Besides the figures below, a video film can be downloaded at [www.humphrey.org.uk/handwalkers.htm](http://www.humphrey.org.uk/handwalkers.htm) ). When they are at rest the quadrupeds either sit upright or squat on their haunches. They are able to stand upright, without support, if they concentrate on doing so, and they lock their knees in a normal human way; but they become unsteady if they try to walk bipedally, and soon go down onto their hands. Their preferred form of locomotion, even when climbing or descending steps, is on all fours (Figs. 2-3). They move in this way fluently and effectively, and seemingly without discomfort. This contrasts markedly with normal adult humans who find such a gait – if and when they try it – tiring and uncomfortable even after practice<sup>6</sup>.

They step with their hands and feet in both diagonal and lateral sequence gaits<sup>7</sup>. The hands are placed palm down, with the weight taken on the wrists and lower ulnar area of the palm. The fingers are either arched so that the finger-tips make light contact with the ground or else are raised entirely clear (so that they can in fact hold objects while walking). The arms and also the back legs are nearly straight and stiff during the stance phase, with the bottom raised high, and the backbone remaining straight throughout the gait. Even as they step with their feet, the knees show relatively little flexion, so that the leg movements actually resemble those of normal human bipedal locomotion. The females splay their back legs apart, the male, however, who is the strongest and most active of the five, plants his feet closely together.

The local villagers laugh at and tease them. Because of this, the females tend to stay close to the house, but the male sometimes wanders for several kilometres. He helps raise money for his family by collecting cans and bottles, which he carries home in a pouch made from his shirt, held by his teeth. He is remarkably agile. We watched him moving easily across rough terrain in search of collectibles. While he searched ahead, his hands anticipated the contours of the rocks, so that he placed them deftly without looking down. He was able to run ahead of us, carrying his mouth bag – while at the same time, to show off, he kicked one of his legs in the air (Fig. 2d).



A



B



C



D

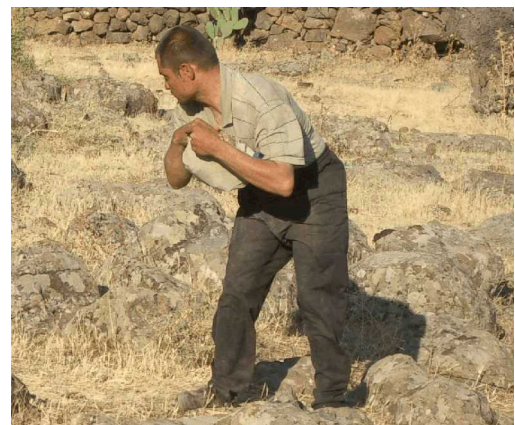

E

Figure 2

(A) Subject # 5 walking near her family home. (B) Subject # 10. (C) Subjects # 5 and #10 entering the hospital. (D) Subject # 11 kicking out with his foot, to show off. (E) Subject # 11 standing semi-erect, while he scans for objects to pick up and put into his pouch.





Figure 3

Subject # 11 walking fast in the yard of his home. (The video frames are 160 ms apart.)

The male, like his sisters, can stand upright with his legs straight. But, while he was out in the field, we also saw him adopt a more ape-like stance: as he stood to scan his surroundings, he leant forward with his knees bent and his back arched (Fig. 2e). The muscles of his lower back appear to be exceptionally well developed.

All their hands are heavily callused in the area of the ulnar palm and wrist where they make contact with the ground (Fig. 4). But their fingers have been protected by being raised off the ground and show little extra wear. Even though their hands are used for locomotion, they retain considerable dexterity. They are slower than normal at manual tasks, and apparently must give the task their full attention. Nonetheless, the females are able to thread needles and do delicate crochet-work (Fig. 5). One of them was observed to use both hands to perform the complex sequence of actions needed to tie her headscarf neatly in a knot above



her head. The male, mimicking one of the investigators smoking a cigarette, broke off a twig to make a pretend cigarette, held it to his lips between two fingers, and flicked off the ash.



Figure 4

The hands of Subject # 11 showing calluses where he walks on his posterior palms

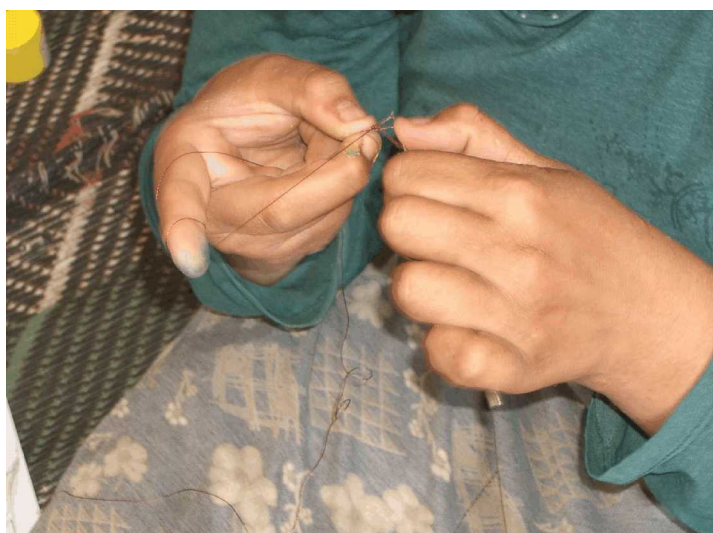

Figure 5

Subject #17, working with needle and thread.

They have not attended school and have had limited exposure to the world beyond their home compound. They are mentally retarded, to differing degrees. Although we heard rumours – still repeated by their neighbours – that they do not speak a human language and make only animal-like noises, they can all speak and understand Kurdish well enough to communicate within their own family, and three of them also speak some Turkish; but their articulation is poor, and it seems they have a restricted vocabulary and difficulties with syntax. They have reasonably good interpersonal skills. They interacted with us as visitors in a friendly and courteous way; and when we took them in a bus to the hospital in the local town, for medical tests, they were alert and interested.

All five show signs of cerebellar dysfunction including: intention tremor, dysdiadochokinesis (inability to execute rapidly alternating movements particularly of the limbs), dysmetria (lack of coordination of movement typified by under- or over-shooting the intended position), and nystagmus (involuntary rhythmic eye movement, with the eyes moving quickly in one direction, and then slowly in the other). However, the cerebellar signs are relatively mild, and they are no more pronounced in the quadrupeds than in the one affected brother who walks bipedally.

MRI scans of the brain confirm, as expected, that all the affected individuals have cerebellar hypoplasia, particularly affecting the vermis (Fig. 6). The cerebral cortex also shows mild atrophy and the corpus callosum is reduced.

In general muscles and joints appear to have been little affected by walking quadrupedally. However the male in particular has reduced flexion in his wrists and restricted movement of his neck (compared to one of his bipedal brothers). X-rays of the skeleton, undertaken for a medical check-up, revealed no obvious abnormalities in wrists, neck or pelvis.

### **3. Developmental Origins**

The continuation of quadrupedal walking into adulthood has not to our knowledge ever been reported previously (with the possible exception of anecdotal accounts of “feral children”<sup>8</sup>). The discovery of these five quadrupedal siblings therefore presents a considerable theoretical challenge.

Whatever else may be going on, the explanation must presumably begin with the dysfunction of the cerebellum. Without the cerebellar problem, these individuals would surely have learned to walk bipedally, like their unaffected siblings. And yet, even *with* the cerebellar



Figure 6

MRI of Subject #11, midline sagittal section. Note reduction of cerebellar vermis, and thinning of corpus callosum.

problem, it might have been expected they would have achieved bipedal walking in some manner. The capacity for walking upright is highly resilient in human beings. In fact humans typically remain bipedal in the face of much greater obstacles to balance and coordination than those experienced by the subjects we have described here. Individuals with bilateral labyrinthine dysfunction<sup>9</sup>, and loss of lower limb proprioceptive sensation<sup>10</sup> are nonetheless typically bipedal. Bipedality can even occur in the complete absence of the cerebellum. There is a recent report of a young man with congenital agenesis of the cerebellum who nevertheless learned to walk and ride a bicycle<sup>11</sup>.

Given all this evidence that, other things being equal, bipedality is indeed the norm, it seems fair to assume that in this particular family other things were not equal. That is to say, additional factors must have been at work, operating in the childhood environment, that combined with the ataxia to produce the unprecedented outcome. Since we do not have reliable evidence about how the gait developed, we can only speculate as to what these other factors may have been. But we do have clues.

The majority of human beings as infants go through a stage of crawling on hands and knees. But a small proportion go on to use a form of crawl in which they support themselves on their hands and feet with their bodies raised above the ground. In the general population this so-called “bear crawl” is not common (a study of 150 infants in the USA reported just 5% using it as a dominant gait<sup>12</sup>); but it tends to run in families, suggesting it may be a heritable trait<sup>13</sup>.

The bear-crawl has several advantages over more typical knee-crawling, and it can temporarily prove to be an especially good way of getting around. Indeed Ales Hrdlicka, who seventy five years ago wrote a definitive (though now largely forgotten) treatise on this kind of crawling, *Children Who Run on All Fours*, remarked that “The most common effect of the all-fours method of progression appears to be more or less of a delay in walking erect. . . These children are quite satisfied with their easy and rapid on-all-fours, and were they left to their own devices and not influenced by other examples, they might possibly keep on, on hands and feet, for a longer time if not indefinitely”<sup>14</sup>.

Normal infants who crawl this way nonetheless almost always make the transition to bipedal walking within a few months. However, suppose now that an infant who was a bear-crawler were also to have a congenital brain condition which made balancing on two legs unusually difficult. Suppose moreover that such an infant were, in Hrdlicka’s words, to be less than usual “influenced by other examples” (or, more to the point, more than usual influenced by similar examples within its own family), and furthermore that the infant were to be more than usual “left to its own devices” by its caretakers. The stage might well be set for a version of the bear-crawl gait to be carried on into later life, becoming modified and improved until it did in fact become an effective substitute for bipedalism.

Such a scenario is hypothetical and, unless new cases are found, it has to remain so. But, in its support, we can at least mention some suggestive evidence. (i) The mother of the quadrupeds informed us that all nineteen of her children – the normal ones as well as the quadrupeds -- were in fact bear-crawlers as infants. (ii) We know as a fact that in this family, after the first such child, there were other quadrupedal children to serve as models. (iii) We were told by the father that he regarded his “crippled children” as a gift, sent by God so as to provide him with the opportunity to prove his capacity to love and take care of them. (iv) A local doctor, whom we called to examine them, said he thought the attitude of the family to their children’s disability would have been one of passive acceptance, and that so far as he

could tell there had never been any attempt at physiotherapy (something, which even at this late stage, might still be able to get them on their feet).

#### **4. Evolutionary Implications**

If the persistence of quadrupedal walking in these five siblings has been the result not simply of a cerebellar problem but of a combination of unusual factors – genetic, physiological, psychological and social – then, to the extent that the conjunction of these factors in one family is highly improbable, it is a syndrome that may never be seen again. However, even if it is indeed a one-off pathological condition, we think there may be anthropological lessons to be learned from it. For, as we stressed at the start, the gait of these adult quadrupeds has unprecedented features, not seen either in human infants or in other primates: notably, it is a case of wrist-walking, combined with a typically human bipedal use of the back-legs.

Given that all five individuals developed the same adult gait, as if following the same developmental programme, there are grounds for asking: where could the “memory” for such a programme have come from? Does it in fact represent an atavistic trait, that has been exposed – possibly for the first time in recent human history – by the remarkable conjunction of circumstances?

There are two main theories about how the human bipedal gait evolved. One is that human ancestors evolved from being quadrupedal tree-climbers to being bipedal ground-dwellers<sup>15</sup>; the other is that they went through an intermediary stage of being quadrupedal knuckle-walkers who were also climbers, like the great apes<sup>16</sup>. But there is a third possibility, originally suggested by Russel Tuttle<sup>19</sup>, which is that they went from being quadrupedal climbers to being quadrupedal wrist-walkers with a restricted repertory of climbing abilities. Wrist-walking might have been an especially adaptive gait for early terrestrial hominids who, while still quadrupedal, were on the way to becoming bipedal, since it would have protected the fingers and allowed them to evolve greater dexterity. Knuckle-walking, by contrast, would have put limits on the evolution of dexterity<sup>17</sup>.

The debate about whether or not the australopithecines were knuckle-walkers has, till now, been biased by the fact that there has been no living example of a quadrupedal hominid other than the apes. But the discovery of these human wrist-walkers changes the situation. We think it arguable that, in these modern human quadrupeds, we are indeed seeing the “rediscovery” of something very like the quadrupedal gait used by our ancestors. At the very

least we would say this discovery presents a challenge to proponents of knuckle-walking to show why it is not unparsimonious to model the gait of the australopithecines on the gait of chimpanzees when we now have a model in the gait of living humans who are not only closer genetically to the australopithecines but are their direct descendants.

### **Acknowledgments**

We are glad to thank Uner Tan for encouraging us to investigate the family, and for providing contacts and support, and him and Osman Demirhan for their scientific comments. Tan and Demirhan were invited to share authorship of this paper, but this did not prove workable. We are grateful to Defne Aruoba, who played a key role as interpreter counsellor and friend to the family, and to Jon Lane who took the video films on behalf of Passionate Productions. The research was partly supported by a grant from Trinity College, Cambridge, to RK. A documentary film relating to the family will be broadcast by the BBC in early 2006.

### **Informed Consent**

The father of the family signed a statement in Turkish which was explained to him by Defne Aruoba. In this statement he consented to his children undergoing medical and other tests related to research on their quadrupedal gait, said he understood that all information of relevance to their welfare would be shared with him, and acknowledged that he had no objections to the research being published. He signed a further statement for the BBC, consenting to film and photographs of his film of his family being broadcast.

### **References**

1. Adolph, K. E. Learning in the development of infant locomotion. *Monogr Soc Res Child Dev* **62**, I-VI, 1-158 (1997).
2. Steinlin, M. Non-progressive congenital ataxias. *Brain Dev* **20**, 199-208 (1998).
3. Hagberg, B., Sanner, G. & Steen, M. The dysequilibrium syndrome in cerebral palsy. Clinical aspects and treatment. *Acta Paediatr Scand Suppl* **226**, 1-63 (1972).
4. Kornegay, J. N. Ataxia, dysmetria, tremor. Cerebellar diseases. *Probl Vet Med* **3**, 409-16 (1991).



5. Schurig, V., Orman, A. V. & Bowen, P. Nonprogressive cerebellar disorder with mental retardation and autosomal recessive inheritance in Hutterites. *Am J Med Genet* **9**, 43-53 (1981).
6. Sparrow, W. A. Creeping patterns of human adults and infants. *Am J Phys Anthropol* **78**, 387-401 (1989).
7. Hildebrand, M. Symmetrical gaits of primates. *Am J Phys Anthropol* **26**, 119 -130 (1967).
8. Singh, J. A. L., Zingg, R. M. & Feuerbach, P. J. A. *Wolf-children and feral man* (Archon Books, [Hamden, Conn.], 1966).
9. Glasauer, S., Amorim, M. A., Vitte, E. & Berthoz, A. Goal-directed linear locomotion in normal and labyrinthine-defective subjects. *Exp Brain Res* **98**, 323-35 (1994).
10. Bloem, B. R., Allum, J. H., Carpenter, M. G., Verschuur, J. J. & Honegger, F. Triggering of balance corrections and compensatory strategies in a patient with total leg proprioceptive loss. *Exp Brain Res* **142**, 91-107 (2002).
11. Titomanlio, L., Romano, A. & Del Giudice, E. Cerebellar agenesis. *Neurology* **64**, E21 (2005).
12. Trettien, A. Creeping and walking. *Am J Psychol* **12**, 1-57 (1900)
13. Hrdlicka, A. *Children who run on all fours, and other animal-like behaviors in the human child* (McGraw-Hill, New York, 1931).
14. Ibid., p.48.
15. Tuttle, R. Knuckle-walking and the evolution of hominoid hands. *Am J Phys Anthropol* **26**, 171-206 (1967).
16. Richmond, B. G. & Strait, D. S. Evidence that humans evolved from a knuckle-walking ancestor. *Nature* **404**, 382-5 (2000)
17. Tuttle, R. H. Quantitative and functional studies on the hands of the Anthropoidea. I. The Hominoidea. *J Morphol* **128**, 309-63 (1969)