

Supercritical carbon dioxide as solvent in the lipase-catalyzed ethanolysis of fish oil: kinetic study

Rodrigo Melgosa^a, M. Teresa Sanz^{*a}, Ángela G. Solaesa^a, Esther de Paz^a, Sagrario Beltrán^a, Daniela L. Lamas^b

^aDepartment of Biotechnology and Food Science (Chemical Engineering Section), University of Burgos, Burgos, Spain

^bInstituto Nacional de Investigación y Desarrollo Pesquero (INIDEP), Buenos Aires, Argentina

*tersanz@ubu.es Fax: 0034947258831

Abstract

Supercritical carbon dioxide (SC-CO₂) has been used as green solvent in the lipase-catalyzed ethanolysis of fish oil by Lipozyme RM IM at mild, non-oxidative conditions and with no solvent residues. The effect of experimental conditions, initial substrate ethanol/oil molar ratio (2-38), pressure (7.5-30 MPa), and temperature (323.15-353.15 K) on equilibrium conversion, reaction rate and oxidative status of the products has been studied. No ethanol inhibition has been observed at high concentrations of ethanol, when putting in contact first the fish oil with the enzyme avoiding direct contact between the biocatalyst and ethanol. Operating pressure affected positively the reaction performance in the range investigated. Visual observation of the phase behaviour of the initial reaction mixture showed an “expanded liquid phase” that helped enhancing reaction rate, and a gas phase. Raising temperature accelerated the reaction up to a limit (343.15 K), observing higher enzyme thermal stability than in other reaction media (313.15 K). However, lipid oxidation increases with temperature. Up to 86 ± 1 % FAEE yield has been found at MR = 6:1, 30 MPa and

323.15 K. Kinetic data have been correlated by using a mathematical model based on the elementary reactions of the 3-step transesterification. Kinetic rate constants, apparent activation volumes and energies are reported for the first time for a lipase-catalyzed ethanolysis reaction in SC-CO₂.

Keywords

Omega 3, lipase, ethanolysis, supercritical carbon dioxide.

1. Introduction

Fish oil is a natural source of omega-3 polyunsaturated fatty acids (n-3 PUFAs) such as eicosapentaenoic acid (EPA, 20:5 n-3) and docosahexaenoic acid (DHA, 22:6 n-3). Health benefits of these compounds have been well established in the literature [1]. As a consequence, functional foods enriched with n-3 PUFAs have been the type of functional food products whose production in Europe and USA has increased the most in the last years [2]. Nevertheless, in a recently published review it has been found that the excess of oxidation in commercial n-3 PUFA supplements affects between 11-62% of the analysed supplements [3]. Traditional methods for production of n-3 PUFA concentrates from their natural sources have been recently reviewed, and a number of novel techniques have been proposed [2]. Among the latest, enzymatic modification of oils rich in n-3 PUFAs in supercritical fluids (SCFs) rises as an alternative for obtaining less oxidized fish oil derivatives, compared to conventional methods.

Several studies have been carried out on enzymatic reactions in different SCF media. A comprehensive review on this subject was carried out by Knez [4], with references on different enzymatic reactions in dense gases, such as oxidation, hydrolysis, esterification and

transesterification. Supercritical carbon dioxide (SC-CO₂) is probably the most used SCF due to its benefits (non-toxic, non-flammable, readily available at high purities and low costs, and relatively mild critical conditions, easily separated from the reaction products by simple depressurization) that are appealing when choosing environmental replacement for organic solvents. Besides, by varying the temperature and pressure it allows the fractionation of the products.

Some previous studies of enzymatic ethanolysis of natural lipid sources in SC-CO₂ have been reported in the literature. Different immobilized lipases have been used as biocatalyst, such as the non-specific lipase Novozyme 435 from *Candida Antarctica* [5-8] and the *sn*-1,3-regiospecific lipase Lipozyme TL-IM from *Thermomucor lanuginosa* [9, 10]. In this work, Lipozyme RM IM from *Rhizomucor miehei*, a *sn*-1,3 specific lipase, has been used as biocatalyst. Ethanolysis of palm kernel oil in SC-CO₂ by the homologous Lipozyme IM was studied by Oliveira and Oliveira [7]. Although the biocatalyst was reported to be *sn*-1,3-specific, it did not behave as a regiospecific lipase and considerable amounts of glycerol were found in the reaction products. Furthermore, the reaction conversion was followed in terms of glycerol production, not taking into account the reaction intermediates (di- and monoacylglycerides). Kondo *et al.* [11] carried out the synthesis of fatty acid ethyl esters (FAEEs) from SC-CO₂-extracted canola oil in a continuous supercritical extraction-reaction (SFE-SFR) system by using Lipozyme RM IM as biocatalyst, observing a decrease in the FAEE production at high ethanol concentration.

Enzymatic reactions in SC-CO₂ can be affected by operating pressure in different ways. According to transition state theory and standard thermodynamics, operating pressure can affect the reaction rate constants. Besides, density-related changes in the physical parameters of SC-CO₂ may indirectly affect the enzyme catalytic activity, and thus the reaction

performance [12]. Loss *et al.* [13] have recently reviewed different applications of supercritical fluids as alternative solvent for biocatalysis processes, concluding that there seems to be no “rule of thumb” for predicting the effect of pressure on enzyme activity in SC-CO₂.

Direct effects of pressure on enzyme residual activity and stability of Lipozyme RM IM have been previously investigated, finding that almost no changes occurred in the range between 10 and 25 MPa at 323.15 K [14]. Different results have been found in the literature regarding the effect of pressure on Lipozyme RM IM-catalyzed reactions in SC-CO₂. For instance, in the study of esterification of stearic acid with ethanol catalyzed by Lipozyme IM in SC-CO₂ in the range from 6 to 20 MPa at 323.15 K, Nakaya *et al.* [15] found an increase in esterification rate with an increase in pressure, but a maximum was found in the hydrolysis rate of the corresponding ethyl stearate. Laudani *et al.* [16] performed a detailed kinetic and thermodynamic study of the esterification of oleic acid with 1-octanol catalyzed by Lipozyme RM IM in dense carbon dioxide. These authors reported a positive effect of increasing pressure from 8 to 10 MPa at 323.15 K. Further increase in pressure up to 30 MPa led to a decrease in reaction conversion from 84 % to 77 %. Therefore, the effect of pressure on enzyme activity in CO₂ is very dependent not only on the specific enzyme, but also on the reaction studied and the phase behaviour of the system at different pressure and temperature conditions.

In this work, the effect of the initial molar ratio of substrates, pressure, and temperature on equilibrium yield and reaction rate has been studied for the ethanolysis of fish oil in SC-CO₂, covering a wider range than previous works reported in the literature. Additionally, oxidation parameters of the refined fish oil and the reaction products obtained from the reactions in SC-CO₂ have been determined and compared with those obtained from reactions performed in

conventional organic solvents and in solvent-free media at atmospheric pressure. This way, optimal reaction conditions considering kinetic aspects and quality of the products can be determined. Experimental data have been satisfactorily correlated by a simple semi-empirical kinetic model based on the elementary reactions that may occur in this system and taking into account reaction intermediates.

2. Material and Methods

2.1. Materials

Lipozyme RM IM, a lipase from *Rhizomucor miehei* immobilized on a macroporous resin, was purchased from Novozymes A/S (Denmark). Refined fish oil was kindly provided by AFAMSA S.A. (Spain) being a mixture of tuna (*Thunnus* sp.) and sardine (*Sardina pilchardus*) oil. Fatty acid profile of the fish oil has been previously reported with a 24 % mol of docosahexaenoic acid (DHA) and 7 % mol of eicosapentanoic acid (EPA) [17]. Absolute ethanol (99.9 %) was purchased from Merck KGaA. Carbon dioxide (99.9%) was supplied by Air Liquide S.A. (Spain). All other chemicals used in different analyses were of analytical or HPLC grade.

2.2. Ethanolysis of fish oil in SC-CO₂

The ethanolysis reaction has been performed in a high pressure batch stirred tank reactor (HP-BSTR) made of stainless steel (SS-316) and having an internal volume of 100 mL. A schematic diagram of the experimental apparatus is shown in Figure 1.

In a typical experiment, a weighed amount of enzyme (5.0 % wt. of substrates) was added into the reactor together with a known amount of fish oil. Subsequently, ethanol was added according to the established initial substrate molar ratio. This procedure was adopted in order

to avoid direct contact of ethanol with the enzyme, which may cause inactivation of the catalyst. The reactor was then closed, connected to the pressure circuit and placed in a thermostatic water bath at the desired operating temperature. Subsequently, SC-CO₂ was fed into the reactor by means of a high pressure pump (ISCO 260 D) up to the desired pressure, which was maintained by a digital pressure controller. A Bourdon pressure gauge also provided a secondary lecture. Once the established conditions have been reached, magnetic stirring was connected and the reaction was initiated.

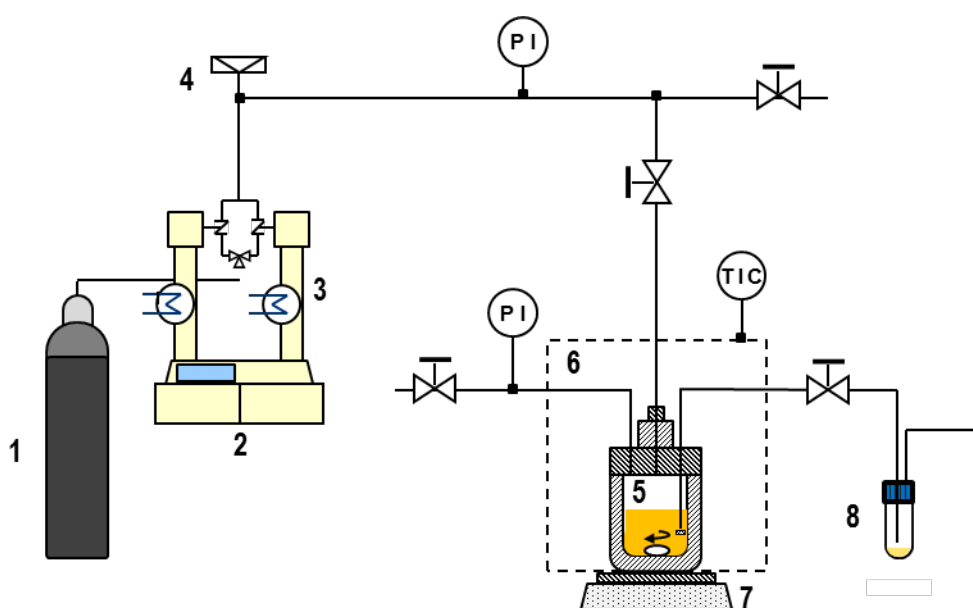

Figure 1. Schematic diagram of the high pressure apparatus used for the ethanolysis reactions in SC-CO₂. 1: CO₂ reservoir; 2: syringe pump; 3: cryostat; 4: rupture disk; 5: high pressure batch stirred tank reactor; 6: thermostatic water bath; 7: magnetic stirrer; 8: sampling device.

Operating temperature and pressure have been varied in the range between 323.15-353.15 K and 7.5-30 MPa, respectively. The effect of the initial substrate molar ratio has been studied in the range from 2:1 to 38:1 (ethanol:fish oil). Samples were taken periodically during 24 h through a siphoned capillary equipped with a microfilter made of sintered steel, which prevented the withdrawal of the enzyme from the reaction mixture. Samples were collected in

glass screw-top vials immersed in a cold trap and stored at -18 °C up to analysis. Pressure drops up to 0.5 MPa were observed during the withdrawal of the samples, which were compensated by feeding fresh SC-CO₂ at the desired pressure into the reactor. According to the low mass of the samples (*ca.* 0.1 g) compared with the initial loading of the HP-BSTR, disturbances of the batch process were considered negligible.

2.3. Determination of the composition

Neutral lipid profile of the samples (fatty acid ethyl esters, FAEEs; Monoacylglycerides, MAGs; diacylglycerides, DAGs; and unreacted triacylglycerides, TAGs) has been determined by normal phase HPLC. Chromatographic equipment, method and calibration procedure have been previously described in detail [18].

Chromatographic analysis of glycerol (GLY) content in the reaction samples was performed using High-Temperature Gas Chromatography (HTGC). Method and calibration procedure have been previously described [17]. GLY content in the reaction samples was also theoretically calculated by a balance of the glycerol backbone, as proposed by Sovová *et al.* for the enzymatic hydrolysis of blackcurrant oil in SC-CO₂ [19]. A modified expression for an ethanolysis reaction gives:

$$n_{\text{GLY}_t} = (n_{\text{FAEE}} - n_{\text{DAG}} - 2 \cdot n_{\text{MAG}})/3 \quad (1)$$

where n_{FAEE} , n_{DAG} , and n_{MAG} are the FAEE, DAG and MAG mole content in the reaction samples and n_{GLY_t} is the theoretical GLY mole content. Theoretical calculation deviated less than 10% from experimental data, thus HT-GC determination of GLY and neutral lipid profile analysis were satisfactorily related.

Unreacted EtOH was theoretically calculated considering the reaction stoichiometry, in which the production of 1 mol of FAEE consumes 1 mol of EtOH, giving:

$$n_{\text{EtOH}} = n_{\text{EtOH},0} - n_{\text{FAEE}} \quad (2)$$

where $n_{\text{EtOH},0}$ is the initial mole content of ethanol.

2.4. Measurement of lipid oxidation

Determination of the peroxide value (PV), p-anisidine value (p-AnV), and acid value (AV) of the samples before and after the kinetic experiments have been performed in order to evaluate potential lipid oxidation processes during the ethanolsis reactions. The peroxide value, PV, measures the concentration of peroxides and hydroperoxides formed in the initial stages of lipid oxidation (primary oxidation). The p-anisidine value (p-AnV) is an estimation of the concentration of secondary oxidation products. Determination of the acid value (AV) has been also performed as an estimation of the hydrolytic rancidity of the fish oil and the reaction samples. All determinations were performed according to standard methods [20-22]. In the case of reaction samples, lipid fractions were obtained by means of evaporation of unreacted ethanol in a vacuum rotary evaporator (Heidolph).

2.5. Kinetic model

Lipase-catalyzed ethanolsis of triacylglycerides (TAG) of fish oil can be considered as a 3-step transesterification. At each step, one molecule of FAEE and a glyceride containing one fewer ester bond are obtained. Glycerides involved in the reaction are di- and monoacylglycerides (DAG and MAG), and glycerol (GLY) as the last product. Following the proposed model, the reaction takes place through the following steps:

1. Conversion of tri- to diacylglycerides:

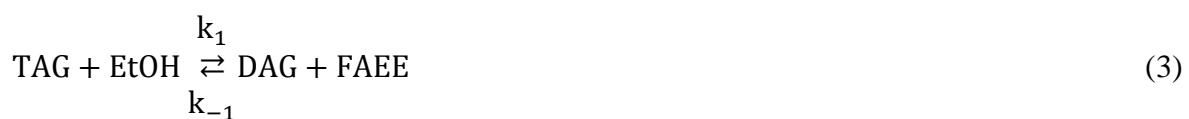

2. Conversion of di- to monoacylglycerides:



3. Conversion of monoacylglycerides to glycerol:



To correlate the experimental kinetic data, a semi-empirical model based on the mass balance equations of all the species in the reaction system has been employed. Although the *sn*-1,3-specific catalyst cannot deacylate the *sn*-2 position of the acylglyceride, step 3 (Eq. 5) should be considered because isomerization of 2-MAG to 1(3)-MAG (acyl-migration) may occur. As the regioisomers 1,2- and 1,3-DAG; and 1(3)- and 2-MAG could not be distinguished with the applied analytical procedure, no difference was made between them in the model. Hydrolysis reaction has not been taken into account since no free fatty acids were detected (<0.1%). The kinetic equations involved in the ethanolysis system are the following:

$$d(n_{\text{TAG}}/n_{\text{total}})/dt = -k'_1 \cdot X_{\text{TAG}} \cdot X_{\text{EtOH}} + k'_{-1} \cdot X_{\text{DAG}} \cdot X_{\text{FAEE}} \quad (6.1)$$

$$d(n_{\text{DAG}}/n_{\text{total}})/dt = k'_1 \cdot X_{\text{TAG}} \cdot X_{\text{EtOH}} - k'_{-1} \cdot X_{\text{DAG}} \cdot X_{\text{FAEE}} - k'_2 \cdot X_{\text{DAG}} \cdot X_{\text{EtOH}} + k'_{-2} \cdot X_{\text{MAG}} \cdot X_{\text{FAEE}} \quad (6.2)$$

$$d(n_{\text{MAG}}/n_{\text{total}})/dt = k'_2 \cdot X_{\text{DAG}} \cdot X_{\text{EtOH}} - k'_{-2} \cdot X_{\text{MAG}} \cdot X_{\text{FAEE}} - k'_3 \cdot X_{\text{MAG}} \cdot X_{\text{EtOH}} + k'_{-3} \cdot X_{\text{GLY}} \cdot X_{\text{FAEE}} \quad (6.3)$$

$$d(n_{\text{GLY}}/n_{\text{total}})/dt = k'_3 \cdot X_{\text{MAG}} \cdot X_{\text{EtOH}} - k'_{-3} \cdot X_{\text{GLY}} \cdot X_{\text{FAEE}} \quad (6.4)$$

$$d(n_{\text{FAEE}}/n_{\text{total}})/dt = k'_1 \cdot X_{\text{TAG}} \cdot X_{\text{EtOH}} - k'_{-1} \cdot X_{\text{DAG}} \cdot X_{\text{FAEE}} + k'_2 \cdot X_{\text{DAG}} \cdot X_{\text{EtOH}} - k'_{-2} \cdot X_{\text{MAG}} \cdot X_{\text{FAEE}} + k'_3 \cdot X_{\text{MAG}} \cdot X_{\text{EtOH}} - k'_{-3} \cdot X_{\text{GLY}} \cdot X_{\text{FAEE}} \quad (6.5)$$

$$d(n_{\text{EtOH}}/n_{\text{total}})/dt = -k'_1 \cdot X_{\text{TAG}} \cdot X_{\text{EtOH}} + k'_{-1} \cdot X_{\text{DAG}} \cdot X_{\text{FAEE}} - k'_2 \cdot X_{\text{DAG}} \cdot X_{\text{EtOH}} + k'_{-2} \cdot X_{\text{MAG}} \cdot X_{\text{FAEE}} - k'_3 \cdot X_{\text{MAG}} \cdot X_{\text{EtOH}} + k'_{-3} \cdot X_{\text{GLY}} \cdot X_{\text{FAEE}} \quad (6.6)$$

$$n_{\text{total}} = n_{\text{TAG}} + n_{\text{DAG}} + n_{\text{MAG}} + n_{\text{FAEE}} + n_{\text{GLY}} + n_{\text{EtOH}} \quad (6.7)$$

The three reversible reactions have been considered as elementary reactions; therefore forward and reverse reactions are expected to follow a second order kinetic, being k'_1 , k'_2 and k'_3 the forward rate constant and k'_{-1} , k'_{-2} and k'_{-3} the reverse rate constants for the lipase catalyzed reaction. Concentrations of reaction products are expressed as mole fraction. The effective forward and reverse rate constants, k'_i and k'_{-i} , have been simultaneously estimated except when varying the molar ratio, MR. In this work, the differential equations were solved numerically with a fourth-order Runge-Kutta method and by reducing the experimental kinetic data minimizing the following objective function (O.F.):

$$\text{O.F.} = \left(\sum_{\text{all samples}} \sum_{i=1}^n (x_{i,\text{exp}} - x_{i,\text{calc}})^2 \right) / n_{\text{samples}} \cdot 100 \quad (7)$$

by using the Simplex-Nelder-Mead method. The subscript i refers to the different components in the ethanolysis system. The subscripts “exp” and “calc” refer to the experimental and calculated mole fraction of the different components for each experimental kinetic data (n_{samples}).

3. Results and Discussion

In this section, the effect of various operating variables, such as pressure (p), temperature (T) and initial molar ratio of substrates (MR) on the performance of the enzymatic ethanolysis of fish oil in SC-CO₂ is presented. Besides, an evaluation of the oxidative and hydrolytic rancidity of the fish oil used as a substrate and of the reaction products obtained in different reaction media (SC-CO₂, *tert*-pentanol and solvent-free) is performed.

Figure 2 shows the time course of the ethanolysis reaction of tuna and sardine oil by Lipozyme RM IM in SC-CO₂ at MR = 38:1, 10 MPa and 323.15 K. From this figure, it can be

seen that production of FAEE is very rapid at the beginning of the reaction and then it becomes slower, reaching a plateau at the equilibrium conversion.

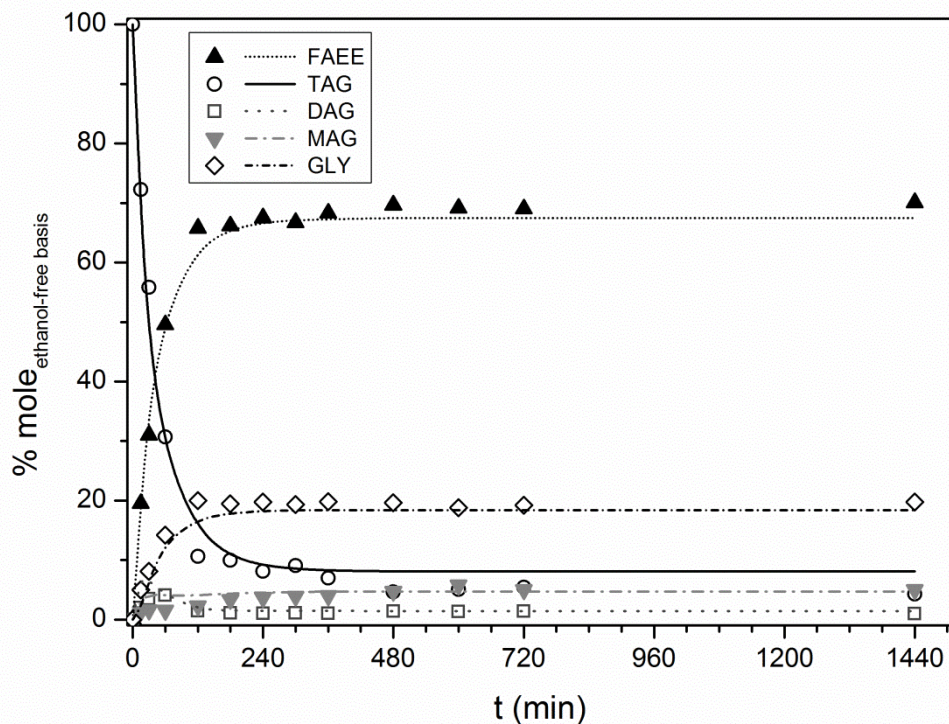

Figure 2. Components profile in the ethanolysis of fish oil catalyzed by Lipozyme RM IM in SC-CO₂ medium. Experimental conditions: MR = 38:1, p = 10 MPa, T = 323.15 K and enzyme loading 5 % wt. of substrates. FAEE: fatty acid ethyl esters, TAG: triacylglycerides, DAG: diacylglycerides, MAG: monoacylglycerides, GLY: glycerol. Lines represent the fitting of the proposed kinetic model to the experimental data.

Lipozyme RM IM is reported to act preferentially towards the *sn*-1,3 positions of the glycerol backbone, thus the reaction was supposed to stop at step 2 (Eq. 4) with accumulation of MAG and an almost negligible GLY production. However, Figure 2 shows low concentration of MAG and a high production of GLY. A similar trend was observed in all the kinetic experiments. An explanation may be provided considering the acyl-migration phenomenon, which may have been enhanced by the catalyst support, Duolite A568, which is a macroporous hydrophilic weak base anion resin, and it has been reported to promote acyl-

migration [23]. Reaction time, temperature, solvents and water content in the medium may also play an important role in the acyl-migration phenomenon [24].

In order to consider the small amounts of the intermediates, MAG and DAG in the reaction medium, as well as the unreacted TAG, FAEE conversion yields have been calculated as a fraction of all the lipid compounds detected in the reaction sample:

$$\text{FAEE yield (\%)} = x_{\text{FAEE}} / (x_{\text{TAG}} + x_{\text{DAG}} + x_{\text{MAG}} + x_{\text{FAEE}}) \cdot 100 \quad (8)$$

Table 1 summarizes the results obtained in this work in terms of FAEE yield at equilibrium conditions and initial reaction rate in the experimental range investigated. Initial reaction rate, expressed as production of FAEE per mass of catalyst and reaction time, was calculated by linear regression of experimental data in the early stages of the kinetics, when a constant reaction rate can be observed.

Table 1. Experimental conditions (initial molar ratio of substrates, MR; pressure, p; temperature, T) for the ethanolysis of fish oil by Lipozyme RM IM in SC-CO₂. Observed initial reaction rate and yield of fatty acid ethyl esters (FAEE) at equilibrium conditions for the ethanolysis reactions at different experimental conditions.

Exp.	MR (ethanol:oil)	T (K)	p (MPa)	Initial reaction rate ($\mu\text{mol} \cdot \text{g}_{\text{enz}}^{-1} \cdot \text{min}^{-1}$)	Eq. FAEE Yield* (%)
1	2:1	323.15	10	34 ± 2	57 ± 3
2	4:1	323.15	10	43 ± 5	70 ± 2
3	6:1	323.15	10	71 ± 5	82 ± 2
4	10:1	323.15	10	79 ± 3	84 ± 1
5	38:1	323.15	10	130 ± 10	86 ± 1
6	6:1	323.15	7.5	51 ± 7	51.4 ± 0.3
7	6:1	323.15	9	67 ± 6	80 ± 3
8	6:1	323.15	20	110 ± 10	82.1 ± 0.7
9	6:1	323.15	30	210 ± 20	86 ± 1
10	6:1	338.15	10	110 ± 10	82.3 ± 0.5
11	6:1	343.15	10	160 ± 20	82 ± 1
12	6:1	353.15	10	64 ± 5	75.0 ± 0.3

Catalyst loading: 5 % wt. of substrates

* Eq. FAEE yield (%) = $x_{\text{FAEE}} / (x_{\text{TAG}} + x_{\text{DAG}} + x_{\text{MAG}} + x_{\text{FAEE}}) \cdot 100$

3.1. Effect of the initial substrate molar ratio

Initial substrate molar ratio (MR) has been studied in the range from 2:1 to 38:1 (ethanol:fish oil) at 10 MPa, 323.15 K and enzyme loading of 5% wt. of substrates. Figure 3 shows a positive effect of increasing MR on the FAEE yield in the covered range. Based on the mutual solubility data of the substrates (ethanol + oil), which have been previously investigated [17], experiments performed at MR = 10:1 and 38:1 form a two-phase reaction mixture at atmospheric pressure. However, initial reaction rate steadily increases when increasing MR (Table 1) in SC-CO₂ as reaction medium, thus no mass transfer limitations occurred. Visual observation of the ternary system in a High-Pressure View Cell (Eurotechnica GmbH) showed that the incorporation of SC-CO₂ as a reaction solvent promoted the reaction bulk to become homogeneous, as it has been also observed by Ciftci and Temelli [25] in the system corn oil, methanol and CO₂. Besides, the rapidly produced FAEE and the reaction intermediates may also act as mutual solvents.

Inhibition of Lipozyme RM IM by high concentration of low-molecular-weight alcohols has been reported in various studies and it has been attributed to a stripping effect of the essential water from the enzyme structure [26]. However, this phenomenon has not been observed in the MR range covered in this work (2:1-38:1 ethanol:oil). It could have been avoided by charging the catalyst and the fish oil together in the HP-BSTR, because fish oil surrounds the enzyme and ethanol would diffuse through the oil layer, not being at high concentration in the enzyme environment. An additional kinetic experiment (data not shown) showed that preventing the catalyst from being in direct contact with ethanol may be a suitable strategy to avoid inhibition. This additional experiment was performed at the same conditions as exp. 5 (MR = 38:1; T = 323.15; p = 10 MPa) except for the order of addition of the reactants. In this case, weighted quantities of fish oil and ethanol were placed together into the HP-BSTR. At

this MR and atmospheric pressure, the system is partially immiscible [17]. Subsequently, the catalyst was added depositing in the interphase. Then, reaction was carried out as reported in the experimental section for a typical experiment. However, maximum FAEE yield of this experiment was found to be as low as 6.50 % mole, showing that special care should be taken when loading the substrates and the catalyst.

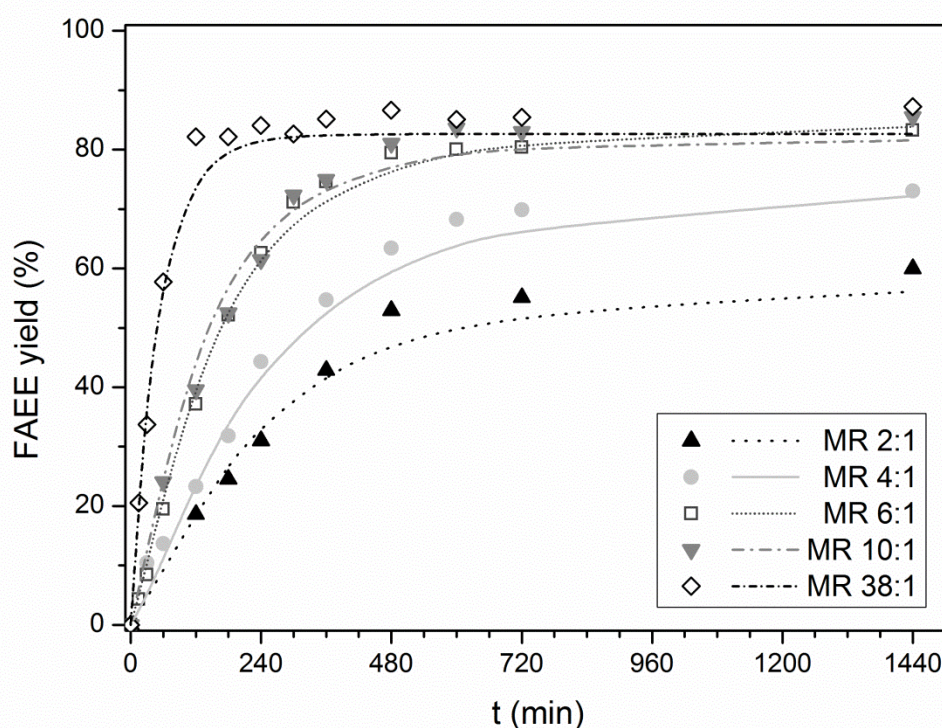

Figure 3. Effect of initial molar ratio of substrates (MR) on the FAEE yield in the ethanolysis of fish oil catalyzed by Lipozyme RM IM in SC-CO₂ medium. Experimental conditions: $p = 10$ MPa, $T = 323.15$ K and enzyme loading 5 % wt. of substrates. Lines represent the fitting of the proposed kinetic model to the experimental data.

In the literature, different results have been reported regarding the effect of ethanol on Lipozyme RM IM. Kondo *et al.* [11] found that FAEE production was inhibited by a large excess of ethanol in a continuous supercritical extractor-reactor, favouring an increase in the

DAG content, the first reaction intermediate of TAG ethanolysis, at the highest concentration of ethanol studied (10% wt. of the CO₂ feed). On the other hand, several authors [27,28] have found appreciable conversion yields (around 80% wt.) in the ethanolysis of different natural lipid sources by Lipozyme RM IM in solvent-free media at MR higher than the stoichiometric (4:1 and 6:1 ethanol:oil). Oliveira and Oliveira [7] reported MR in the range 1:1 to 10:1 (ethanol:oil) as the variable that most positively affected the conversion yield of the enzymatic ethanolysis of palm kernel oil in SC-CO₂ by Lipozyme IM. They pointed at migration of ethanol to the vapour phase as the responsible for this positive effect and the lack of inhibition. However, it must be highlighted that the lipid substrate and the catalyst was firstly placed together into the reactor and then a pre-established amount of ethanol was introduced, following a similar experimental procedure as the one described in this work.

The FAEE yield at equilibrium is represented as a function of MR in Figure 4a. From this figure, it can be noticed that the FAEE yield at equilibrium exhibits an asymptotic dependence on MR remaining practically constant at MR higher than 10:1. A similar expression of the one proposed by Chesterfield *et al.* for the ethanolysis of waste cooking oil [29] gives the following relationship for the FAEE yield at equilibrium and MR:

$$\text{Eq. FAEE yield (\%)} = a/(1+\exp((MR_0 - MR)/b)) \quad (9)$$

Non-linear regression was performed by using the Marquardt algorithm (Statgraphics) giving $a = 85.81 \%$ defined as the limiting equilibrium FAEE yield [29], $b = 2.14$ and $MR_0 = 0.518$ with $R^2 = 0.982$. Figure 4b shows that a double-logarithmic relationship can be established between initial reaction rate and MR ($\ln r_o = 0.4644 \cdot \ln MR + 3.2461$; $R^2 = 0.9463$).

Table 2 lists the kinetic rate constants (k'_i) calculated from the proposed model (Eqs. 6.1-6.7), as well as the value of the O.F. (Eq. 7) for the kinetic experiments performed at different MR.

Equilibrium constants for each reaction step, evaluated as $K_i = k'_i/k_{-i}$, are also reported. To our knowledge, this is the first time that kinetic rate constants are reported for the three steps of a lipase-catalyzed ethanolysis in SC-CO₂.

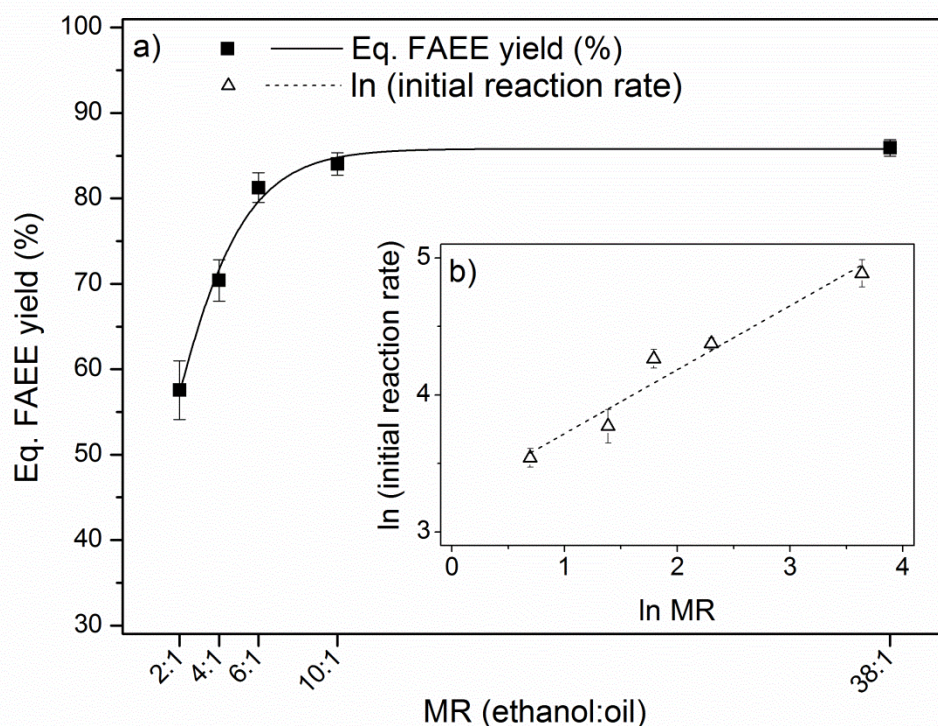

Figure 4. a) Equilibrium FAEE yield (%) vs. MR (ethanol :oil) in the ethanolysis of fish oil catalyzed by Lipozyme RM IM in SC-CO₂ medium. Solid line is from the non-linear regression of the experimental data (Eq. 9). b) Logarithmic relationship between initial reaction rate and MR. Dashed line is from the linear regression of the experimental data. Experimental conditions: $p = 10$ MPa, $T = 323.15$ K and enzyme loading 5 % wt. of substrates

As it can be observed from Table 2, the forward and reverse rate constants follow the order $k'_3 > k'_2 > k'_1$ and $k'_{-2} > k'_{-3} > k'_{-1}$. An increase in MR leads to an increase in both the forward and the reverse rate constants. In the MR range studied, the forward rate constant of the third step (MAG to produce FAEE, k'_3) is larger than the other two forward rate constants, being the initial breakdown of TAG the slowest step and therefore the rate-limiting step of the

ethanolysis reaction. This behaviour has been also described in the literature for either acid or base-catalyzed transesterification [30]. It can be also noticed that equilibrium constants monotonously decreased with increasing MR due to the excess of ethanol employed. Besides, the equilibrium constant of the third reaction step, K_3 , is one order of magnitude higher than those of the other two steps. In the literature, different mechanisms have been proposed for lipase-catalyzed transesterification systems, most of them based on Ping-Pong Bi-Bi models [31]. Comparison with these studies is difficult since in most cases thermodynamic parameters are not provided. In this work, a simple model was adopted and surprisingly, leads to kinetic and equilibrium parameters of the same order as those reported by chemical-catalysis [30].

Table 2. Effective forward (k'_i) and reverse (k'_{-i}) reaction rate constants, equilibrium constants (K_i) and objective function (O.F.) values of the proposed kinetic model for the ethanolysis of fish oil by Lipozyme RM IM in SC-CO₂ at different initial molar ratio of substrates (MR). Reactions were performed at $p = 10$ MPa, $T = 323.15$ K, enzyme loading 5 % wt. of substrates.

MR (ethanol:oil)	k'_1 (min ⁻¹)	k'_{-1} (min ⁻¹)	K_1	k'_2 (min ⁻¹)	k'_{-2} (min ⁻¹)	K_2	k'_3 (min ⁻¹)	k'_{-3} (min ⁻¹)	K_3	O.F.
2:1	0.0971	0.5998	0.1543	1.3972	2.4197	0.5511	3.7926	0.9194	4.1315	0.1704
4:1	0.1703	0.8898	0.1786	1.5682	4.0452	0.3684	5.3823	1.3874	4.0460	0.0592
6:1	0.4764	1.3465	0.4867	3.2605	5.9020	0.5290	7.4221	2.5333	2.6911	0.0309
10:1	0.5177	6.7735	0.0946	22.2968	164.8420	0.1426	11.5229	7.5545	2.1538	0.0137
38:1	3.5370	34.7671	0.0152	16.3786	158.3258	0.1178	27.8656	56.5390	0.2191	0.0047

3.2. Pressure effect

Pressure has been varied in the range from 7.5 to 30 MPa at fixed MR = 6:1 (ethanol:fish oil), 323.15 K and an enzyme loading of 5 % wt. of substrates. Table 1 shows that initial reaction rate steadily increases with pressure from 7.5 to 30 MPa, and FAEE yield at equilibrium increases from 51.4 % near the critical pressure (7.5 MPa) to 80 % at 9 MPa, showing a

plateau around 81-85 % at higher pressures up to 30 MPa (Figure 5). In the range investigated (7.5-30 MPa), no decay in the reaction performance was observed when increasing pressure.

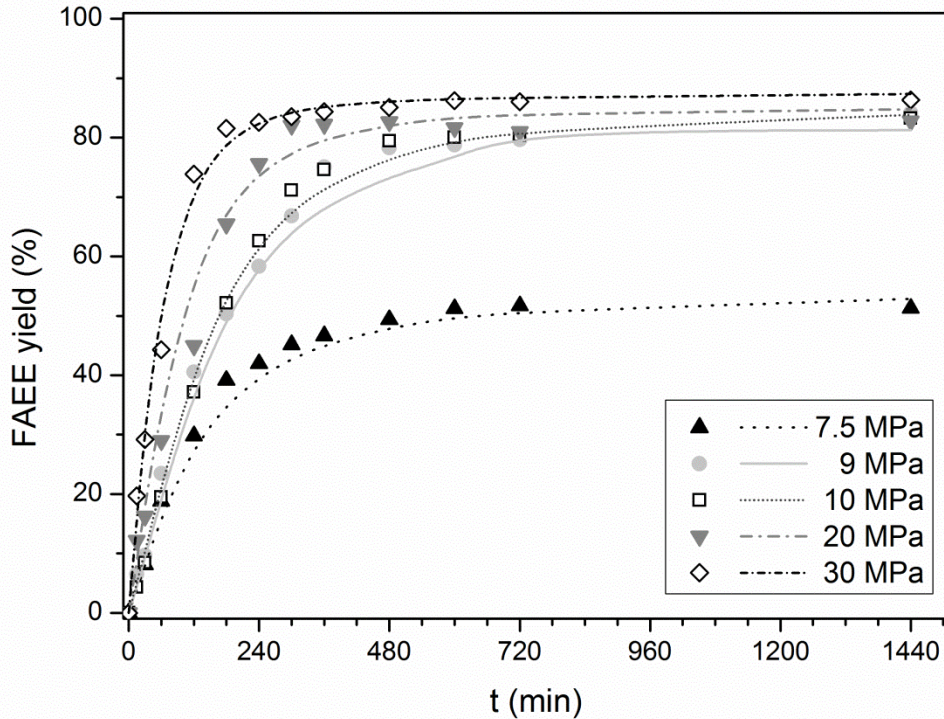

Figure 5. Effect of operating pressure (p) on the ethanolsis of fish oil catalyzed by Lipozyme RM IM in SC- CO_2 medium. Experimental conditions: MR = 6:1, $T = 323.15$ K and enzyme loading 5 % wt. of substrates. Lines represent the fitting of the proposed kinetic model to the experimental data

Figure 6 shows that a semi-logarithmic relationship can be established between initial reaction rate and operating pressure (dashed line, $\ln r_o = 0.4220 \cdot \ln p_r + 3.6157$; $R^2 = 0.9774$). Besides, a similar expression to the one proposed in Eq. 9 can be established to describe the effect of pressure on the equilibrium FAEE yield. Operating pressure was expressed in terms of reduced pressure ($p_r = p/p_c$). Non-linear regression was performed by using the Marquardt algorithm (Statgraphics) giving a limiting equilibrium FAEE yield of 83.47 %, $b = 0.079$ and

$p_{r0} = 0.982$ ($p_0 = 7.22$ MPa) with $R^2 = 0.973$. The continuous line in Figure 6 corresponds to this adjustment.

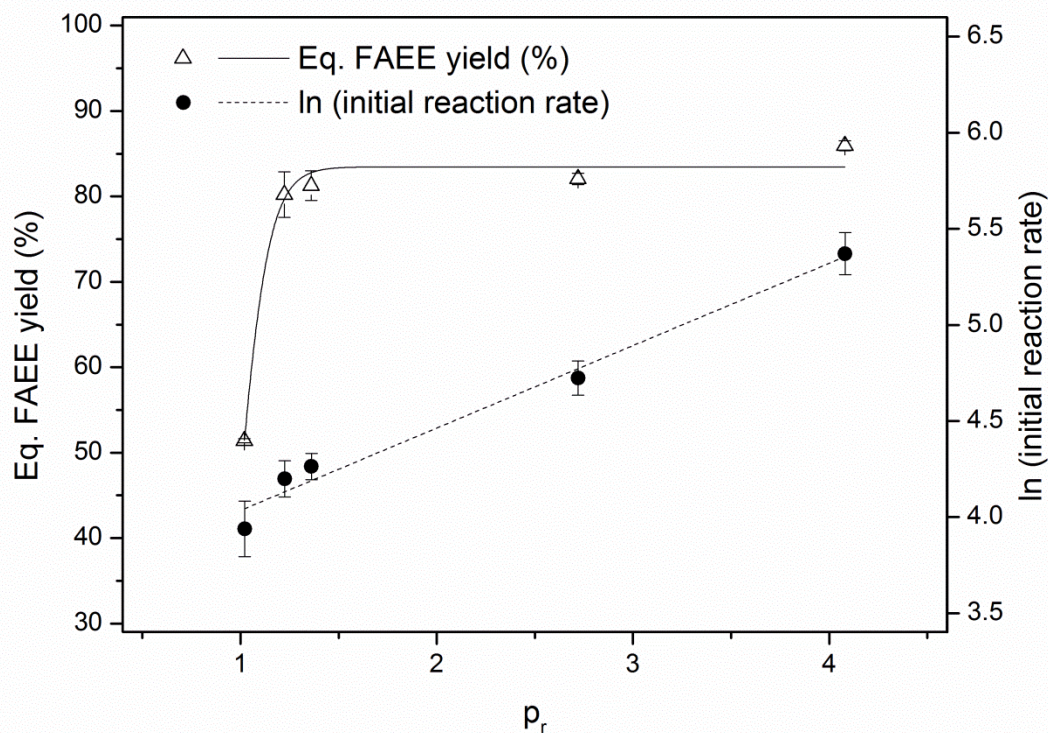

Figure 6. Open triangles: Equilibrium FAEE yield (%) vs. reduced operating pressure ($p_r = p/p_c$) in the ethanolsis of fish oil catalyzed by Lipozyme RM IM in SC-CO₂ medium. Solid line is from the non-linear regression of the experimental data (Eq. 9). Filled circles: logarithmic relationship between initial reaction rate and p_r . Dashed line is from the linear regression of the experimental data. Experimental conditions: MR = 6:1, T = 323.15 K and enzyme loading 5 % wt. of substrates

The effect of operating pressure on the ethanolsis of fish oil by Lipozyme RM IM in SC-CO₂ could be explained considering the phase behaviour of the fish oil/ethanol reaction mixture in SC-CO₂. Visual observations of the initial reaction mixture at the different pressures assayed in this work showed that the reaction system consisted of an “expanded” liquid and a gas phase. At the conditions studied in this work, solubility of CO₂ in ethanol is high [32],

whereas Borch-Jensen and Mollerup [33] reported moderate solubility of CO₂ in fish oil at pressures from 6 to 65 MPa and temperatures from 293.15 to 393.2 K. At none of the temperatures, carbon dioxide and fish oil were completely miscible, but at each temperature, CO₂ solubility in fish oil was found to increase with increasing pressure [33]. This increase in CO₂ solubility with pressure may correspond to the increase in the reaction rate with pressure as shown in Figure 6, since CO₂ solvation results in a better mass transfer reaction medium due to an increase in diffusivity and a reduction of medium viscosity.

The different effects of pressure depending on the phase behaviour of the system can be noted when comparing the results obtained in this work with those from the esterification of oleic acid with *n*-octanol in SC-CO₂ [16]. Phase behaviour of the system oleic acid + *n*-octanol + CO₂ shows that CO₂ is highly soluble in the reaction mixture (oleic acid and ethanol) and the liquid phase can contain up to 70 % mole of CO₂ near the critical point of CO₂ [16]. Further increase in operating pressure promoted a decrease in conversion due to more CO₂ solvating in the reaction bulk and leading to dilution of the substrates. On the contrary, the mixture fish oil + ethanol can dissolve a much lower amount of CO₂ (30 % mole at MR = 6:1, 10 MPa and 323.15 K, according to analytical determination of the phase behaviour in a high pressure view cell). Therefore, dilution of the substrates at high pressure is not supposed to strongly affect the reaction performance in the fish oil + ethanol + CO₂ reaction system.

Oliveira and Oliveira [7] adopted a Taguchi experimental design to assess the influence of the process variables on the ethanolysis of palm kernel oil in SC-CO₂ catalyzed by Lipozyme IM. According to their results, Lipozyme IM was positively affected by pressure, although MR was the variable that more strongly affected the conversion. For this enzyme they found an optimum at 14.6 MPa. On the contrary, in the present work, no maximum in the pressure was

found in the range from 7.5 to 30 MPa, although similar phase behaviour could be expected for both reaction mixtures (fish oil + ethanol + CO₂ or palm kernel oil + ethanol + CO₂).

The effect of pressure on the kinetic rate constants has been taken into account by using the transition-state theory and classical thermodynamics. Following this approach, the variation of the reaction rate constant k'_i with pressure for a bimolecular reaction “A + B = M* = products” can be expressed as follows [12]:

$$(\partial \ln(k)/\partial p)_T = -\Delta V^*/RT \quad (10.1)$$

where k is the rate constant of the reaction expressed in pressure-independent concentration units, ΔV^* is the apparent activation volume, T is the operating temperature and R is the gas constant. The direct integration of Eq 10.1 is not straightforward since activation volume changes with pressure [12]. However, within a small range of pressure it can be assumed that ΔV^* does not change with pressure and Eq. 10.1 can be easily integrated, giving:

$$k'_i = k_{0,i} \cdot \exp(-p \cdot \Delta V_i^*/RT) \quad (10.2)$$

where the subscript i refers to the different steps in the ethanolysis reaction. Following this expression, pre-exponential kinetic constants, $k_{0,i}$, and apparent activation volumes, ΔV_i^* , have been simultaneously estimated for the experiments performed in the range 9-30 MPa. Results obtained are listed in Table 3. Kinetic parameters for the experiment performed at $p = 7.5$ MPa were estimated separately because of the marked changes in the physical properties of the solvent near the critical region ($p_r = 1.02$). In the pressure range 9-30 MPa, apparent activation volumes were negative ($\Delta V_i^* < 0$) for all the reaction steps, which indicates that reaction rate constants will increase with increasing pressure. It can be observed that ΔV^* for the forward first and third reaction steps are lower (or higher in absolute value) than the corresponding ΔV^* for the reverse reaction, being this steps more sensitive to an

increase in operating pressure. On the contrary, the DAG to MAG conversion shows similar ΔV^* values for the forward and reverse reactions, which suggest little influence of pressure in this step. Overall consideration of ΔV^* values indicates that FAEE production may be favoured by increasing pressure, as it can be observed from the experimental results.

To our knowledge, no ΔV^* values have been previously reported for lipase-catalyzed ethanolysis in SC-CO₂. However, a similar ΔV^* value of *ca.* -206 cm³·mol⁻¹ was reported by He *et al.* [34] for the transesterification of soybean oil without catalyst in sub- and supercritical methanol between 8.7 MPa and 36 MPa (553 K and MR methanol:soy bean oil = 42:1). In any case, Kamat *et al.* [12] stated that the use of ΔV^* in enzyme-catalyzed reactions must be treated with caution, since changes in pressure will result in multiple variables being changed that also influence the ability of the enzyme to catalyse a given reaction. Therefore ΔV^* should not be used to compare the effects of pressure for catalyzed and uncatalyzed reactions. For an uncatalyzed reaction, data are only dependent of direct pressure-effects and no indirect effects of pressure are transmitted via the enzyme.

Table 3. Values for the forward ($k_{0,i}$) and reverse ($k_{0,-i}$) pre-exponential constants, apparent activation volume of each forward (ΔV^*_{i}) and reverse (ΔV^*_{-i}) reaction step and values of the objective function (O.F.) of the proposed kinetic model for the ethanolysis of fish oil by Lipozyme RM IM in SC-CO₂ at 7.5 MPa and in the range 9-30 MPa. Reactions were performed at MR = 6:1, T = 323.15 K, enzyme loading 5 % wt. of substrates.

p (MPa)	k_{0,1} (min ⁻¹)	k_{0,-1} (min ⁻¹)	ΔV[*]₁ (cm ³ mol ⁻¹)	ΔV[*]₋₁ (cm ³ mol ⁻¹)	k_{0,2} (min ⁻¹)	k_{0,-2} (min ⁻¹)	ΔV[*]₂ (cm ³ mol ⁻¹)	ΔV[*]₋₂ (cm ³ mol ⁻¹)	k_{0,3} (min ⁻¹)	k_{0,-3} (min ⁻¹)	ΔV[*]₃ (cm ³ mol ⁻¹)	ΔV[*]₋₃ (cm ³ mol ⁻¹)	O.F.
9 – 30	0.2366	1.1770	-158.0394	-47.6628	1.5824	2.6906	-126.3835	-127.7673	3.0135	1.7217	-145.7125	-88.7143	0.0889
7.5	k' ₁ = 0.3099		k' ₋₁ = 43.1938		k' ₂ = 2.3257		k' ₋₂ = 12.1366		k' ₃ = 43.8870		k' ₋₃ = 45.9396		0.0087

3.3. Temperature effect

To assess the effect of temperature on the kinetics of the ethanolysis of fish oil by Lipozyme RM IM in SC-CO₂, operating temperature has been varied between 323.15 and 353.15 K. Initial substrate molar ratio (6:1 ethanol:fish oil), pressure (10 MPa) and enzyme loading (5% wt. of substrates) remained unchanged.

Figure 7 shows that FAEE yield at equilibrium was similar in the temperature range from 323.15 to 343.15 K. The heat of reaction is generally small for many transesterification systems; therefore the equilibrium conversion observed for the ethyl esters is essentially temperature independent [35]. Raising temperature from 323.15 to 343.15 K resulted in an increase of the initial reaction rate (Table 1 and Figure 8), probably because of a higher kinetic energy of the molecules. Besides, lower viscosity and higher diffusivity of the solvent at higher temperatures may lead to lower mass transfer limitations [4]. The highest temperature assayed in this work (353.15 K) led to lower equilibrium FAEE yield (Table 1 and Figure 7), which may be due to thermal deactivation of the catalyst. The effect of temperature on initial reaction rate is shown in the Arrhenius plot (Figure 8). From this figure, it can be seen that the Arrhenius dependence is no longer valid at temperatures higher than 343.15 K. As it has been previously mentioned, this behaviour may correspond to thermal deactivation of the catalyst.

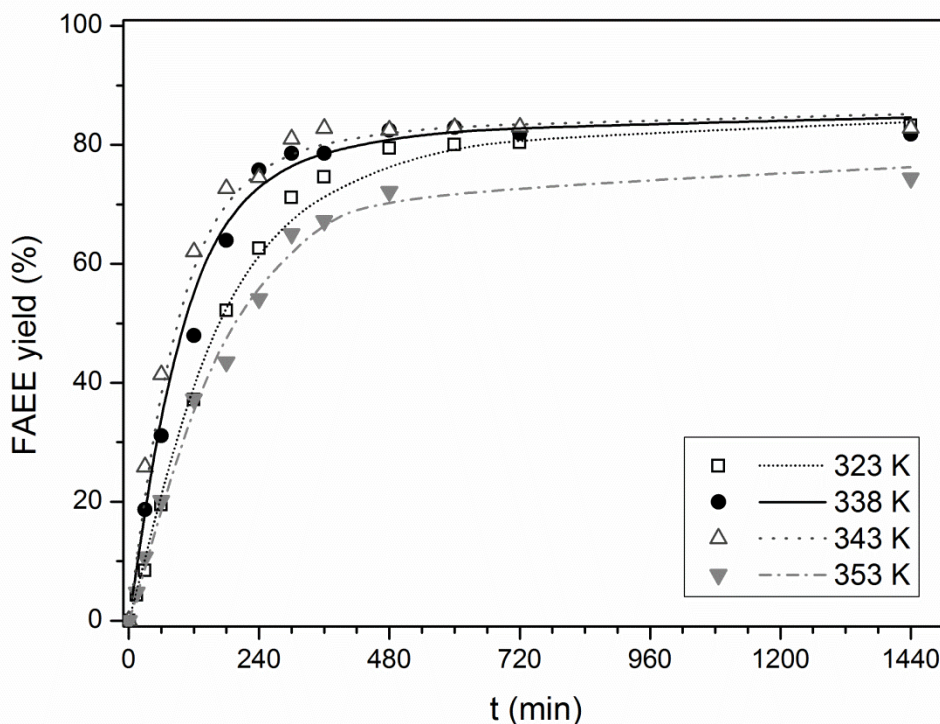

Figure 7. Effect of operating temperature (T) on the ethanolsis of fish oil catalyzed by Lipozyme RM IM in SC-CO₂ medium. Experimental conditions: MR = 6:1, p = 10 MPa and enzyme loading 5 % wt. of substrates. Lines represent the fitting of the proposed kinetic model to the experimental data.

Similar results for thermal behaviour of Lipozyme RM IM have been reported in the literature for the synthesis of *n*-octyl oleate in SC-CO₂ [16]. Conversion around 80 % was observed in the range 308.15-333.15 K at 10 MPa, whereas higher temperatures (343.15 and 353.15 K) led to lower conversion (around 65 %) yet slightly higher initial reaction rates, which may indicate that thermal deactivation is not immediate. Oliveira and Oliveira [7] reported T = 324 K as the optimum temperature for the ethanolsis of palm kernel oil by Lipozyme IM in SC-CO₂, whereas 313.15 K was found to be the optimum for the same reaction in *n*-hexane [8]. Recently, Calero *et al.* [28] have found the same operating temperature (T = 313.15 K) as the optimum for the ethanolsis of sunflower oil by Lipozyme RM IM in solvent-free media

(MR = 6:1) and different amounts of biocatalysts. According to the manufacturer of the catalyst, optimum activity temperature for Lipozyme RM IM catalyzed reactions is 313.15 K [36]. Based on these results, it could be concluded that higher thermal stability of the catalyst may be obtained in SC-CO₂ than in organic or solvent-free media [14,16,37]. In any case, it must be highlighted that optimum temperature in reactions involving easily oxidizable compounds such as n-3 PUFAs must consider not only the thermodynamic or kinetic criteria, but also the effect of operating temperature towards lipid oxidation, as it will be discussed in section 3.5. *Lipid oxidation*.

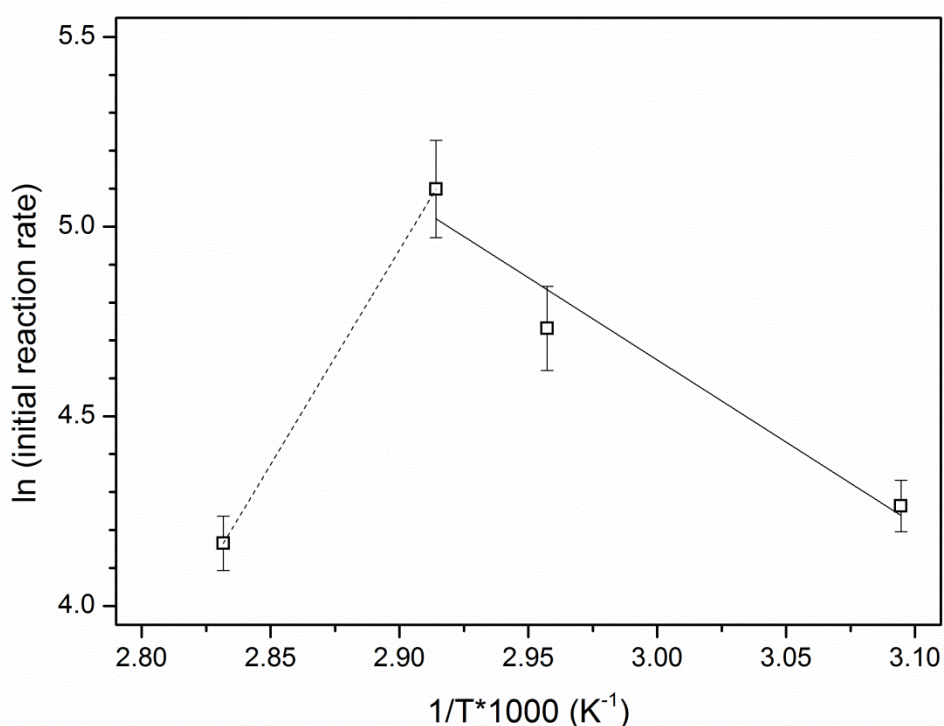

Figure 8. Arrhenius plot for the ethanolysis of fish oil catalyzed by Lipozyme RM IM in SC-CO₂ medium. Lines are from the linear regression of the experimental data. Reactions were performed at MR = 6:1, p = 10 MPa and enzyme loading 5 % wt. of substrates.

The effect of temperature on the kinetic rate constants of the 3-step reaction has been described by the Arrhenius equation in the temperature range from 323.15 to 343.15 K:

$$k'_i = k_{0,i} \cdot \exp(-E_{a,i}/RT) \quad (11)$$

where k_0 is the preexponential factor, E_a is the activation energy of the reaction, T is the operating temperature and R is the gas constant. The subscript i accounts for the different steps of the ethanolysis reaction. Combining this expression and the proposed kinetic model (Eqs. 3-6), experimental data from experiments performed at 323.15, 338.15, and 343.15 K were simultaneously and satisfactorily correlated. The experiment performed at 353.15 K has been excluded from the simultaneous fitting because of thermal inactivation of the catalyst. Estimated pre-exponential constants and activation energies for the ethanolysis of fish oil by Lipozyme RM IM in SC-CO₂ in the temperature range 323.15–343.15 K are listed in Table 4. It can be observed that the first forward step of the reaction, which is also the rate-limiting step, presented the highest estimated value for the activation energy and therefore the highest sensitivity to the reaction temperature.

Table 4. Values for the forward ($k_{0,i}$) and reverse ($k_{0,-i}$) pre-exponential constants, activation energy of each forward ($E_{a,i}$) and reverse ($E_{a,-i}$) reaction step and values of the objective function (O.F.) of the proposed kinetic model for the ethanolysis of fish oil by Lipozyme RM IM in SC-CO₂ in the range 323.15-343.15 K and at 353.15 K. Reactions were performed at MR = 6:1, p = 10 MPa, enzyme loading 5 % wt. of substrates.

T (K)	$k_{0,1}$ (min⁻¹)	$k_{0,-1}$ (min⁻¹)	E_{a1} (kJ mol⁻¹)	E_{a-1} (kJ mol⁻¹)	$k_{0,2}$ (min⁻¹)	$k_{0,-2}$ (min⁻¹)	E_{a2} (kJ mol⁻¹)	E_{a-2} (kJ mol⁻¹)	$k_{0,3}$ (min⁻¹)	$k_{0,-3}$ (min⁻¹)	E_{a3} (kJ mol⁻¹)	E_{a-3} (kJ mol⁻¹)	O.F.
323.15-343.15	59947	85	31.83	10.10	718	1396	14.07	13.95	968	426	12.32	12.67	0.1085
353.15	$k'_{1} = 0.3583$		$k'_{-1} = 2.9463$		$k'_{2} = 2.7859$		$k'_{-2} = 9.9535$		$k'_{3} = 8.6937$		$k'_{-3} = 6.6718$		0.0608

3.4. Comparison of supercritical carbon dioxide, *tert*-pentanol and solvent-free media

Ethanolysis has been carried out at atmospheric pressure in *tert*-pentanol (TP) and in solvent-free medium (SF). For the kinetic performed in *tert*-pentanol, an optimized amount of solvent (20 wt%) was added, based on the liquid-liquid equilibrium of the reaction system [17]. In the kinetic performed in SF medium, no solvent was added to the reaction system and ethanol acted simultaneously as solvent and reactant. Experiments were performed with the same enzyme concentrations as the experiments performed in SC-CO₂ (5wt% of substrates) and MR = 6:1 (ethanol:oil) and T = 323.15 K were chosen to compare the results. Figure 9 allows comparison of the FAEE yields obtained in the three reaction media: TP and SF at atmospheric pressure and SC-CO₂ at two different operating pressures (10 and 30 MPa).

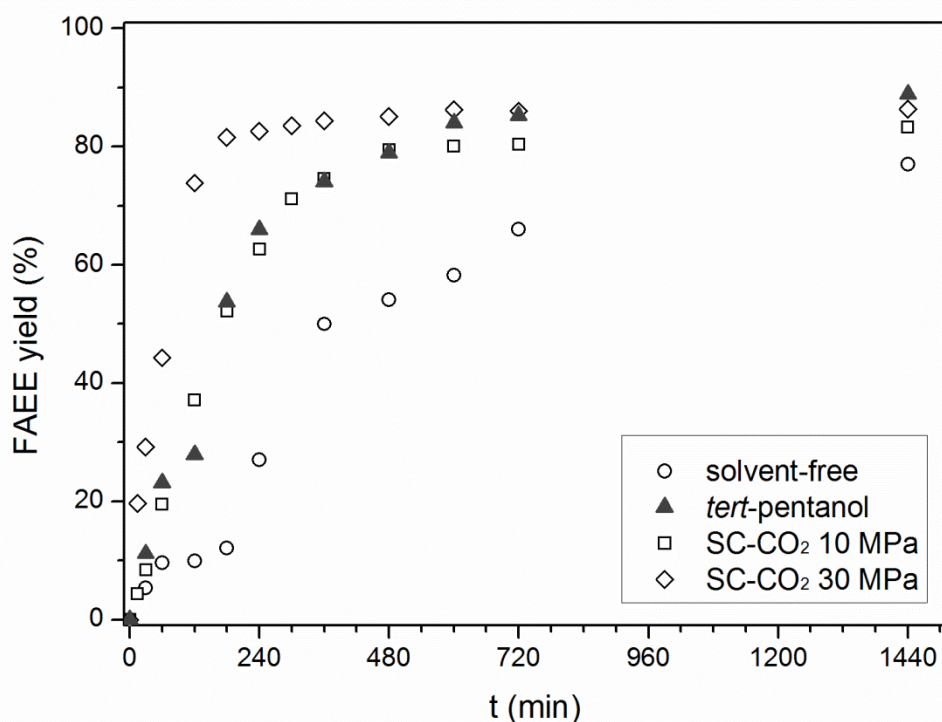

Figure 9. Effect of solvent media on the ethanolysis of fish oil catalyzed by Lipozyme RM IM. Experimental conditions: MR = 6:1, T = 323.15 K and enzyme loading 5 % wt. of substrates (SC-CO₂ at two operating pressure, SF: solvent-free media and 20 wt% of TP).

SF medium presents the lowest reaction rate probably due to higher viscosities of the reaction mixture. Kinetic performance in TP is comparable to the results obtained in SC-CO₂ at 10 MPa. According to the results presented in Figure 9, higher reaction rates are obtained when working in SC-CO₂ at 30 MPa than in TP. This proves that CO₂ dissolved in the reaction mixture plays an important role in the reaction performance by enhancing reaction rates due to better mass transfer properties.

3.5. Lipid oxidation

Peroxide (PV), p-Anisidine (p-AnV), and Acid (AV) Values have been determined for the supplied refined fish oil and for some of the reaction mixtures obtained after 24 h of reaction. AV and PV for the refined fish oil were 0.56 ± 0.01 % oleic acid and 4.99 ± 0.01 meq O₂ kg⁻¹, respectively. AV fulfilled the guidance set by the FDA for food-grade triglycerides rich in n-3 PUFA (1.0 % oleic acid), whereas PV is exactly on the recommended limit [38]. Results obtained for AV and PV after different reaction conditions are plotted in Figures 10 and 11, respectively.

In general, at the same operating temperature (T = 323.15 K) AV and PV in samples from the reactions in SC-CO₂ are lower than the ones from the reactions performed at atmospheric pressure, in which no significant difference is observed between organic solvent (*tert*-pentanol) and solvent-free media. Temperature is the parameter that most negatively affects the oxidation of the final mixture since both PV and AV increase with operating temperature. The highest values were obtained at 353.15 K, the highest T assayed in this work. Although higher reaction rates were obtained with an increase in temperature from 323.15 to 343.15 K, lipid oxidation increases with temperature. Therefore, the optimum operating temperature was the lowest temperature assayed in this work, 323.15 K. On the contrary, operating pressure

affects in a lesser extent the AV and PV of the reaction samples in SC-CO₂ in the range investigated.

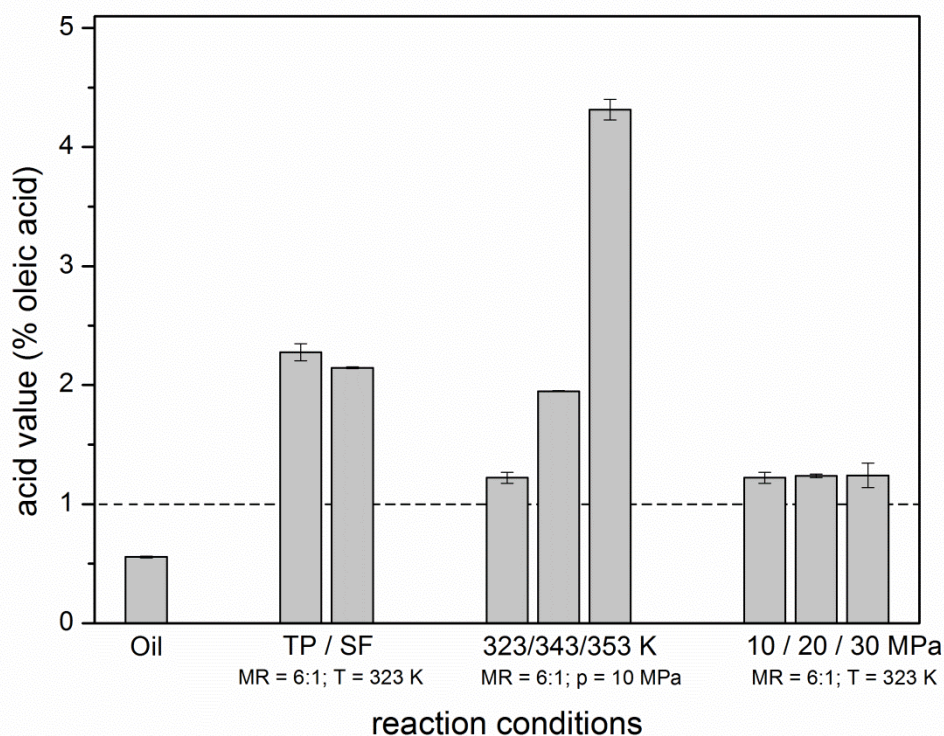

Figure 10. Effect of the ethanolsis of fish oil catalyzed by Lipozyme RM IM on the acid value (AV) in different reaction media: SC-CO₂ at different operating pressure, SF (solvent-free media) and 20 wt% of TP. Dashed line represents the recommended limit set by the FDA [38].

p-AnV for the refined fish oil was found to be 44 ± 1 . This value exceeds the limit recommended by the FDA [38]. Therefore the supplied fish oil was already partially oxidized. However, this value did not change significantly after the ethanolsis reaction either in SC-CO₂ or in conventional organic solvent (*tert*-pentanol) or solvent-free media. Indeed, p-AnV has been reported to be a good measurement of secondary oxidation processes, which are unlikely to happen in the short period of time in which the reaction took place.

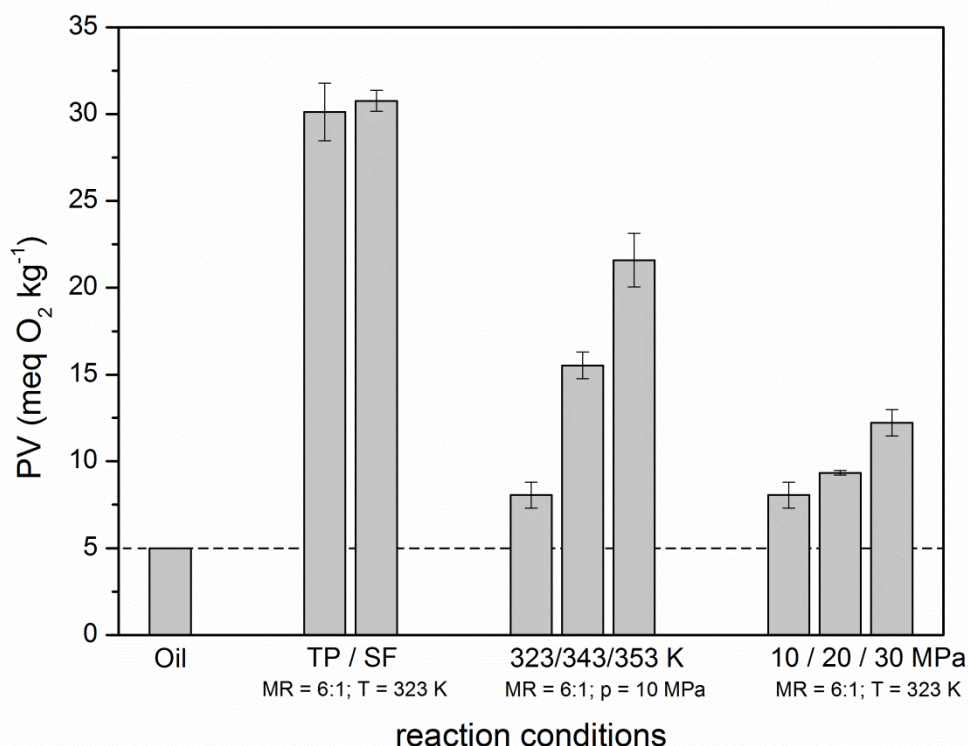

Figure 11. Effect of the ethanolsis of fish oil catalyzed by Lipozyme RM IM on the peroxide value (PV) in different reaction media: SC-CO₂ at different operating pressure, SF (solvent-free media) and 20 wt% of TP. Dashed line represents the recommended limit set by the FDA [38].

To our knowledge, no other studies in the literature assessed lipid oxidation processes during enzymatic ethanolsis of fish oil in SC-CO₂. Park *et al.* [39] determined PV and conjugated diene (CD) content of commercial salmon oil before and after enzymatically (Lipozyme IM) and chemically catalyzed ethanolsis at atmospheric pressure and *n*-hexane as the reaction media. They found that both methods increased PV and CD, yet little oxidation and isomerization of PUFAs were found when Lipozyme IM was used as the catalyst [39]. Results obtained in this work show that enzymatic ethanolsis of fish oil in SC-CO₂ can be considered a suitable method to obtain less oxidized reaction products compared to those obtained by enzymatic ethanolsis in conventional organic solvents or in solvent-free media at atmospheric pressure.

4. Conclusions

SC-CO₂ has been used as a green solvent in the transesterification of fish oil by Lipozyme RM IM, providing an environmentally benign reaction medium. Advantages of using SC-CO₂ include replacing organic solvents, enhancing reaction kinetics by reducing mass transfer limitations and preventing oxidation due to displacement of oxygen. The latter is especially important when working with easily oxidizable compounds such as n-3 PUFAs.

Enzyme and phase behaviour are key parameters to understand bioconversion in SC-CO₂. The lipase showed higher thermal stability in SC-CO₂ reaction medium than in other conventional reaction media. Besides, no ethanol inhibition has been observed when avoiding high concentrations of ethanol in the enzyme environment. Operating pressure affected positively the reaction performance due to solvation of CO₂ in the reaction mixture, which reduces viscosity and improves diffusion coefficients. Lipase-catalyzed ethanolysis in SC-CO₂ has been shown as suitable method to obtain less oxidized n-3 PUFA FAEE compared to other reaction media.

Correlation of the kinetic data to a semi-empirical model showed that the rate-limiting step is the breakdown of triacylglycerides. Similar trends of kinetic and equilibrium parameters have been observed as those reported by chemical-catalysis.

Acknowledgements

To the Spanish Government (MINECO) and the European Regional Development Fund (ERDF) for financial support of the project CTQ2012-39131-C02-01. Financial support from the Junta de Castilla y León and European Regional Development Fund (ERDF) through project BU055U16 is also gratefully acknowledged. RM acknowledges MINECO for a grant

(BES-2013-063937). AGS acknowledges University of Burgos for a fellowship. EP acknowledges MINECO for a fellowship (FJCI-2014-19850).

References

- [1] C. H. S. Ruxton, S. C. Reed, M. J. A. Simpson and K. J. Millington, *Journal of Human Nutrition and Dietetics*, 2004, **17**, 449–459.
- [2] N. Rubio-Rodríguez, S. Beltrán, I. Jaime, S. M. de Diego, M. T. Sanz and J. R. Carballido, *Innovative Food Science and Emerging Technologies*, 2010, **11**, 1–12.
- [3] B. B. Albert, D. Cameron-Smith, P. L. Hofman and W. S. Cutfield, *BioMed Research International*, 2013, **2013**, 464921.
- [4] Ž. Knez, *Journal of Supercritical Fluids*, 2009, **47**, 357–372.
- [5] H. Gunnlaugsdottir and B. Sivik, *Journal of American Oil Chemists' Society*, 1995, **72**, 399–405.
- [6] H. Gunnlaugsdottir, J. Mattias and B. Sivik, *Journal of Supercritical Fluids*, 1998, **12**, 85–93.
- [7] J. V. Oliveira and D. Oliveira, *Industrial and Engineering Chemistry Research*, 2000, **39**, 4450–4454.
- [8] D. Oliveira and J. V. Oliveira, *Journal of Supercritical Fluids*, 2001, **19**, 141–148.
- [9] S.-K. Shin, J.-E. Sim, H. Kishimura, B.-S. Chun, *Journal of Industrial and Engineering Chemistry*, 2012, **18**, 546–550.
- [10] H.-Y. Lee, Tanbirul Haque A.S.M., S.-B. Kim, Y.-B. lee, B.-S. Chun, *Journal of Industrial and Engineering Chemistry*, 2014, **20**, 1097–1102.
- [11] M. Kondo, K. Rezaei, F. Temelli and M. Goto, *Industrial and Engineering Chemical Research*, 2002, **41**, 5770–5774.
- [12] S. V Kamat, E. J. Beckman and A. J. Russell, *Critical Reviews in Biotechnology*, 1995, **15**, 41–71.
- [13] R. Loss, L. Lerin, J. V. Oliveira and D. Oliveira, eds. M. A. Z. Coelho and B. D. Ribeiro, *White Biotechnology for Sustainable Chemistry*, The Royal Society of Chemistry, 2015, 104–135.
- [14] R. Melgosa, M. T. Sanz, Á. G. Solaesa, S. L. Bucio and S. Beltrán, *Journal of Supercritical Fluids*, 2015, **97**, 51–62.
- [15] H. Nakaya, K. Nakamura and O. Miyawaki, *Journal of the American Oil Chemists' Society*, 2002, **79**, 23–27.
- [16] C. G. Laudani, M. Habulin, Ž. Knez, G. Della Porta and E. Reverchon, *Journal of Supercritical Fluids*, 2007, **41**, 92–101.
- [17] S. L. Bucio, A. G. Solaesa, M. T. Sanz, S. Beltrán and R. Melgosa, *Journal of*

- Chemical and Engineering Data*, 2013, **58**, 3118–3124.
- [18] A.G. Solaesa, S.L. Bucio, M. T. Sanz, S. Beltrán, and S. Rebolleda, *Journal of Oleo Science*, 2014, **63**, 449–460.
- [19] H. Sovová, M. Zarevúcka, P. Bernášek and M. Stamenić, *Chemical Engineering Research and Design*, 2008, **86**, 673–681.
- [20] American Oil Chemist' Society, AOCS Official Method Cd 3d-63, 2009.
- [21] AOAC International, AOAC Official Method 965.33, 2002.
- [22] American Oil Chemist' Society, AOCS Official Method Cd 18-90, 2011.
- [23] A. Millqvist Fureby, C. Virto, P. Adlercreutz and B. Mattiasson, *Biocatalysis and Biotransformation*, 1996, **14**, 89–111.
- [24] X. Xu, A. R. H. Skands, C. E. Høy, H. Mu, S. Balchen and J. Adler-Nissen, *Journal of the American Oil Chemists' Society*, 1998, **75**, 1179–1186.
- [25] O. N. Ciftci and F. Temelli, *Journal of Supercritical Fluids*, 2011, **58**, 79–87.
- [26] W. Piyatheerawong, Y. Iwasaki, X. Xu and T. Yamane, *Journal of Molecular Catalysis B: Enzymatic*, 2004, **28**, 19–24.
- [27] V. Kumari, S. Shah and M. N. Gupta, *Energy & Fuels*, 2007, **21**, 368–372.
- [28] J. Calero, C. Verdugo, D. Luna, E. D. Sancho, C. Luna, A. Posadillo, F. M. Bautista and A. A Romero, *New Biotechnology*, 2014, **31**, 596–601.
- [29] D. M. Chesterfield, P. L. Rogers, E. O. Al-Zaini and A. A. Adesina, *Chemical Engineering Journal*, 2012, **207-208**, 701–710.
- [30] A. Sivasamy, K. Y. Cheah, P. Fornasiero, F. Kemausuor, S. Zinoviev and S. Miertus, *ChemSusChem*, 2009, **2**, 278–300.
- [31] B. Cheirsilp, A. H-Kittikun and S. Limkatanyu, *Biochemical Engineering Journal*, 2008, **42**, 261–269.
- [32] J. S. Lim, Y. Y. Lee and H. S. Chun, *Journal of Supercritical Fluids*, 1994, **7**, 219–230.
- [33] C. Borch-Jensen and J. Mollerup, *Fluid Phase Equilibria*, 1997, **138**, 179–211.
- [34] H. He, S. Sun, T. Wang and S. Zhu, *Journal of the American Oil Chemists' Society*, 2007, **84**, 399–404.
- [35] S. L. Bucio, Á. G. Solaesa, M. T. Sanz, R. Melgosa, S. Beltrán and H. Sovová, *Journal of Oleo Science*, 2015, **64**, 431–441.
- [36] D. Oliveira, A. C. Feihmann, A. F. Rubira, M. H. Kunita, C. Dariva and J. V. Oliveira, *Journal of Supercritical Fluids*, 2006, **38**, 373–382.
- [37] R. C. Rodrigues and R. Fernandez-Lafuente, *Journal of Molecular Catalysis B: Enzymatic*, 2010, **66**, 15–32.
- [38] U.S. Department of Health and Human Services, Food and Drug Administration. GRAS Notice 000200, 2006.
- [39] S.-B. Park, Y. Endo, K. Maruyama and K. Fujimoto, *Food Science and Technology*

Research, 2000, **6**, 192–195.