

DIAGNOSIS



The measurement and normalisation of dielectric dissipation factor for diagnostics of transformer insulation

Introduction

The Dielectric Dissipation Factor (DDF) is known as the loss factor or tangent delta of the insulation. The combined transformer insulation includes oil-impregnated cellulose materials and oil. When one of the insulating zones of the transformer is placed between two electrodes (either between windings or between the winding and a metal construction such as the core, frame or tank) under applied voltage, leakage current will flow. This cur-

rent flowing through the insulation has two components – a reactive and an active one. The angle between vectors of these currents, which is close to 90° , and the ratio between them is equal to tangent of the angle ($\text{tg}\delta$) between the vector of the reactive current and the vector of the full leakage current.

The Dielectric Dissipation Factor (DDF)/Tangent Delta ($\text{tg}\delta$) measurement of the transformer insulation is a traditional

ABSTRACT

This article describes additional features of the method of Dielectric Dissipation Factor (DDF)/Tangent Delta ($tg\delta$) measurement for a more accurate diagnosis of the condition of the transformer solid insulation. The proposed method is based on determining the DDF weight of solid insulation and oil in the measured value of DDF for the proper insulation zone of the transformer. The article proposes normalisation of DDF values according to the rated voltage of the transformer, and the analysis of the impact of design combining insulation and its condition on recalculation of DDF measurement results at a given temperature to the base temperature.

KEYWORDS

transformer, dielectric dissipation factor (DDF), transformer insulation

method used for estimation of the transformer insulation condition [1]. The differences between measured DDF values for different transformer insulation zones depend on the construction, condition and temperature of the insulation. Insulation zones are composed of transformer oil and oil impregnated cellulose materials (paper, pressboard, wood and laminated wood) (OIP). Dielectric parameters of oil sample and insulation zones, e.g. high to low voltage windings or windings to the core and tank, can be measured but the parameters of the solid material can only be estimated using special methods. The design of the insulation zones varies for different transformers, and the contribution of the DDF value for each elementary insulation material to the DDF value of the insulation zone is individual for each transformer type. Therefore, using uniform acceptance DDF values for all insulating zones and a uniform correction factor [1] for temperature recalculation is not correct. This article proposes a method of measurement and calculation of DDF and capacitance for different insulating zones of transformers. The interpretation of these results promotes a better diagnostics and estimation of the condition of transformer insulation during the following stages: at the acceptance test of new transformers and after repair, at the test after change or reclaiming of oil, at the test after drying process, during the periodical test.

As a rule, normalisation of the DDF value for a new transformer should not exceed 1 % at the temperature of 20 °C. Some customer requirements limit DDF to a different value according to the rated voltage of the transformer.

” DDF measurement of the transformer insulation is a traditional method used for estimation of the transformer insulation condition

” The design of the insulation zones varies for different transformers and using uniform acceptance DDF values for all zones and a uniform correction factor for temperature recalculation is incorrect

Model of the transformer insulation

Figure 1 presents one of the capacitance models of a transformer where each elementary insulating zone ($C_1 \div C_8$) is the capacitance between relevant parts of the transformer. An equivalent scheme of the elementary insulating zone is shown in Figure 2. The simplified equivalent circuit diagram of the insulation consists of the following capacitances: C_1 with $tg\delta_1$ and C_2 with $tg\delta_2$ for the oil-impregnated cellulose materials, and C_3 with $tg\delta_3$ for the oil. Assuming that $tg\delta_1 = tg\delta_2$, because it is the $tg\delta$ of the same insulating materials, the resulting $tg\delta$ can be presented by equation (1), where coefficients K_1 and K_2 are specific weight factors of $tg\delta_1$ and $tg\delta_3$ in $tg\delta$ of each corresponding insulating zone.

$$tg\delta = K_1 tg\delta_1 + K_3 tg\delta_3 \quad (1)$$

The correctness of calculation of K_1 and K_2 may be checked with equation (2).

$$K_1 + K_2 = 1 \quad (2)$$

The measurements of $tg\delta/C$ are carried out for each insulating zone (Figure 1) at a given temperature in two conditions: transformer with oil and without oil [2]. The relative dielectric permittivity ϵ and $tg\delta_3$ of the oil sample from the transformer are measured at the same temperature.

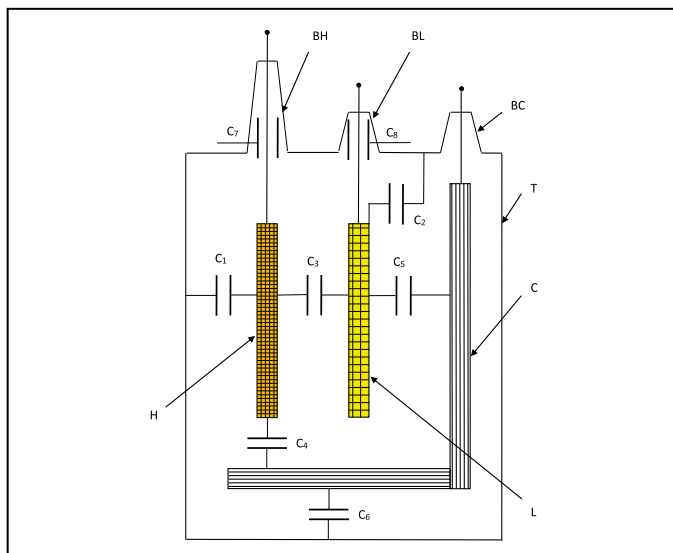

Figure 1. Capacitance model of the transformer

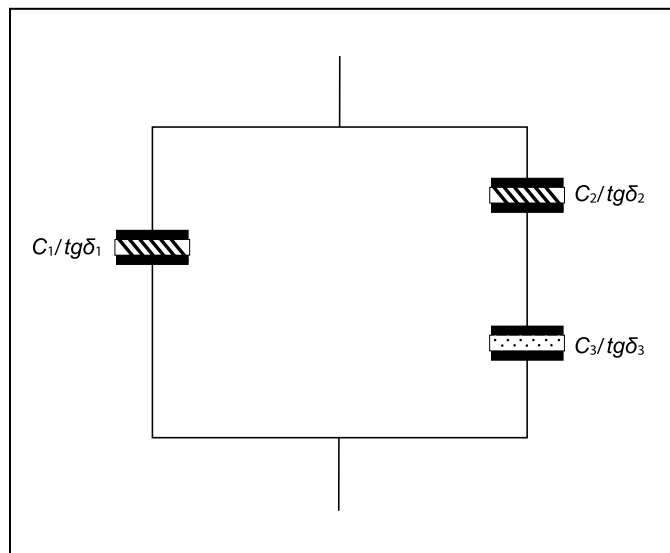

Figure 2. Equivalent scheme of the transformer insulating zone

The system of equations for the equivalent scheme (Figure 2) is presented by (3) and (4), where $j=1$ refers to transformer without oil and $j=2$ to transformer with oil.

$$C_{Xj} = C_1 + \frac{1}{1/C_2 + 1/C_3 \epsilon_j} \quad (3)$$

$$C_{Xj} \text{tg}\delta_{Xj} = C_1 \text{tg}\delta_1 + \frac{\text{tg}\delta_1/C_2 + \text{tg}\delta_3/C_3 \epsilon_j}{(1/C_2 + 1/C_3 \epsilon_j)^2} \quad (4)$$

The definition of unknown parameters C_1, C_2, C_3 (Figure 2) and $\text{tg}\delta_1$ makes it possible to calculate coefficients K_1 and K_2 :

” To estimate the condition of the insulation, it is proposed to calculate the DDF value of solid insulation for each elementary zone and compare it to the proposed limits

$$K_1 = (C_1 + 1 / (C_2 (1/C_2 + 1/C_3 \epsilon)^2)) / C_x \quad (5)$$

$$K_2 = (1 / (C_3 (1/C_2 + 1/C_3 \epsilon)^2)) / C_x \quad (6)$$

Table 1. Test and calculation results for three-phase transformer 50 MVA, 161/24 kV with inner LV winding

Scheme of measurement	T	C_{x1}	C_{x2}	$\text{tg}\delta_{x1}$	$\text{tg}\delta_{x2}$	$\text{tg}\delta_3$	ϵ	C_1	C_2	C_3	$\text{tg}\delta_1$	K_1	K_2
	$^{\circ}\text{C}$	nF	nF	%	%	%		nF	nF	nF	%		
H-T, L+C+G	18	2.92	3.59	0.32	0.28	0.01	2.10	2.27	17.51	0.68	0.41	0.66	0.34
H-C, L+T+G	18	0.33	0.39	1.02	1.16	0.01	2.10	0.10	0.37	0.63	1.38	0.83	0.17
H-L, C+T+G	18	3.05	5.29	0.25	0.21	0.01	2.10	0.75	39.56	2.44	0.85	0.24	0.76
L-T, H+C+G	18	1.08	1.70	0.39	0.34	0.01	2.10	0.41	7.58	0.73	0.90	0.37	0.63
L-C, H+T+G	18	4.24	6.95	0.29	0.31	0.01	2.10	0.99	24.78	3.73	0.88	0.35	0.65
H-T, L+C+G	18	1.30	1.97	0.31	0.35	0.01	2.10	0.38	4.59	1.16	0.72	0.47	0.53

Table 2. Test and calculation results for three-phase transformer 50 MVA, 161/36 kV with inner HV winding

Scheme of measurement	T	C_{x1}	C_{x2}	$\text{tg}\delta_{x1}$	$\text{tg}\delta_{x2}$	$\text{tg}\delta_3$	ϵ	C_1	C_2	C_3	$\text{tg}\delta_1$	K_1	K_2
	$^{\circ}\text{C}$	nF	nF	%	%	%		nF	nF	nF	%		
H-T, L+C+F+G	18	0.20	0.30	0.26	0.30	0.01	2.10	0.06	0.64	0.19	0.58	0.50	0.50
H-F, L+T+C+G	18	0.23	0.27	0.71	0.85	0.01	2.10	0.02	0.31	0.59	1.04	0.81	0.19
H-C, L+T+F+G	18	3.08	4.97	0.24	0.23	0.01	2.10	0.90	18.92	2.47	0.63	0.36	0.64
H-L, C+T+G	18	3.86	5.29	0.27	0.21	0.01	2.10	2.44	35.02	1.48	0.41	0.50	0.50
L-T, H+C+G	18	1.43	2.67	0.12	0.12	0.01	2.10	0.19	24.96	1.31	0.68	0.16	0.84
L-C, H+T+G	18	0.23	0.25	0.90	1.17	0.01	2.10	0.32	-0.06	0.14	1.26	0.93	0.07

” Differences between DDF values for different zones can be explained by the use of different materials, their combination and condition

It is enough to make measurements and calculations for one typical transformer and then use them for all series of the given transformer type. From the equation (1) and (2), it follows that $tg\delta_1$ corresponds to the solid insulation. This can be calculated by equation (7):

$$tg\delta_1 = \frac{tg\delta_{x2} + K_2 tg\delta_3}{1 - K_2} \quad (7)$$

Test results and calculation of insulating parameters

The measurements of $tg\delta/C$ were carried out on a transformer at the factory during the type test in two conditions: with oil and without oil in the tank. The test and calculation results are shown in Tables 1 and 2, where $tg\delta_{x1}/C_{x1}$ represents the capacitance of the insulating zone without oil, and $tg\delta_{x2}/C_{x2}$ the capacitance of the insulating zone with oil, while ϵ is the relative dielectric permittivity of oil sample from the transformer.

The procedure for preparing the transformer for measurement included filling the oil tank with the active part for the routing or type test (including $tg\delta/C$ measurement). The $tg\delta/C$ measurements were performed after draining of oil. This procedure does not require significant costs if transportation of the transformer without oil is provided. A similar procedure could be used after transformer repair.

The measurement insulating zones are as follows: between HV winding (H) and Tank (T); between HV winding (H) and LV winding (L); between HV winding (H) and Core (C); between HV winding (H) and Frame (F); between LV (L) and Core (C); between LV (L) and Frame (F).

During the measurement of each zone all other elements, including the tap measurement of bushings, were connected to the

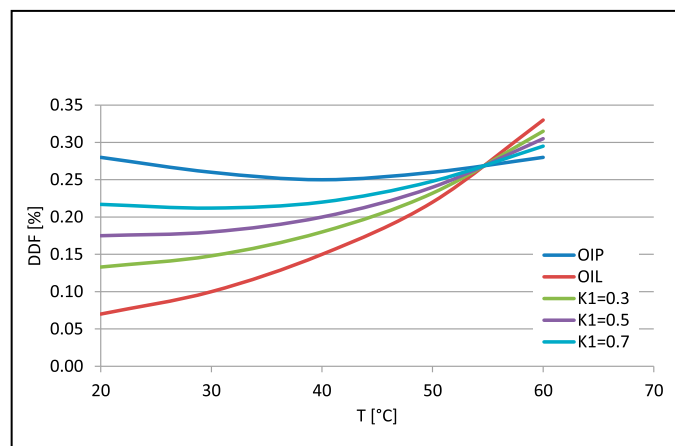

Figure 3. DDF of good oil-impregnated cellulose materials (OIP) and good oil (OIL)

guard (G) of the measurement instrument. Only the current through the relevant insulating zone is measured as the currents flowing through other insulating zones will return on the guard lead of the instrument.

The results showed that the coefficients K_1 and K_2 are different for each zone, which can be attributed to different combination of materials and their geometric dimensions. Some difference between values of $tg\delta$ for different zones can be explained by using different materials, their combination and condition. The use of laminated wood could explain higher values of $tg\delta$ for the zones between the end of the winding and core/frame, because laminated wood includes high polarity substances such as glue.

DDF dependence on temperature

The dependence of DDF on temperature for different zones of insulation is different and defined by the condition of solid insulation and oil. The graphs in the Figures 3 to 6 depicting dependence of DDF on temperature show the influence of the construction (coefficient K_1) and condition of materials [3]. The graphs of oil-impregnated cellulose materials (OIP) and oil (OIL) typically illustrate good/poor conditions of insulation materials. The values for combined insulation with a difference in coefficient K_1 lie in between the values for OIP and OIL.

The test results of $tg\delta$ measured with the decreasing temperature of the transformer 50 MVA, 161/36 kV are presented in Table 3 and Figure 7. The temperature correction factors are different for different zones and illustrated in Figure 8.

Recalculation of the measured $tg\delta$ values at a given temperature to the base temperature performed using the uniform correction factor leads to a significant error.

” The dependence of DDF on temperature is different for different zones of insulation and defined by the condition of solid insulation and oil

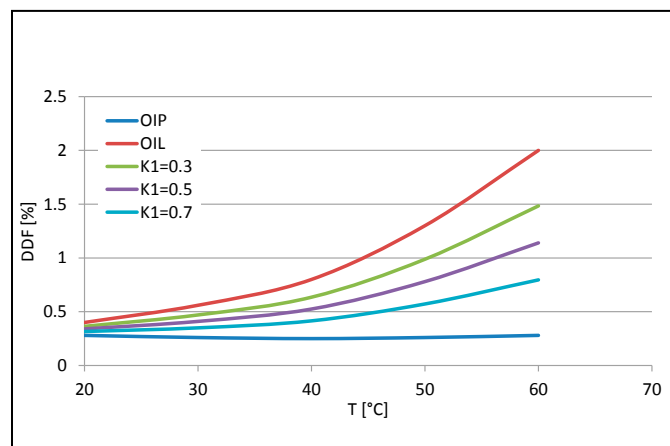

Figure 4. DDF of good oil-impregnated cellulose materials (OIP) and poor oil (OIL)

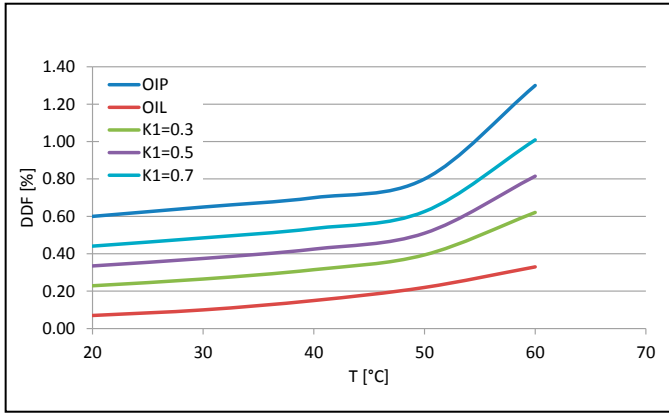

Figure 5. DDF of poor oil-impregnated cellulose materials OIP and good oil (OIL)

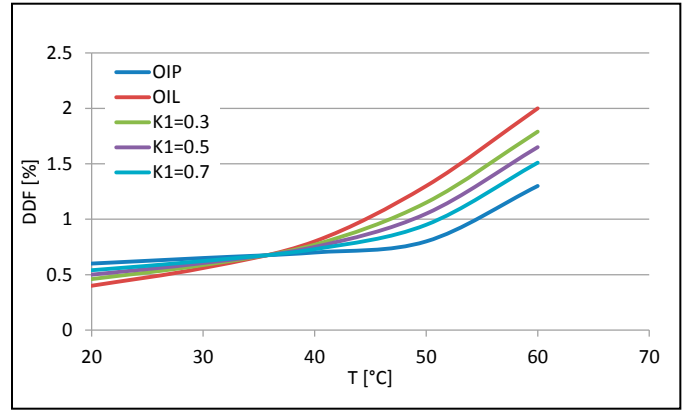

Figure 6. DDF of poor oil-impregnated cellulose materials OIP and poor oil (OIL)

Table 3. Test results of $tg\delta$ measured with the decreasing temperature on a transformer 50 MVA, 161/36 kV

zone/graph T, °C	series						
	H-T	H-F	H-C	H-L	L-T	L-C	C-T
23	0.30	1.24	0.23	0.25	0.14	1.75	0.83
28	0.35	1.44	0.24	0.27	0.14	2.09	0.95
33	0.42	1.69	0.24	0.27	0.15	2.44	1.09
38	0.53	2.00	0.24	0.31	0.16	2.99	1.20
43	0.64	2.18	0.24	0.32	0.16	3.32	1.40
48	0.76	2.37	0.24	0.34	0.19	3.73	1.58
53	0.86	2.54	0.25	0.33	0.21	4.19	1.81
58	0.93	2.67	0.26	0.34	0.26	4.48	2.12
63	1.04	2.75	0.29	0.34	0.35	4.58	2.27
66.5	1.06	2.79	0.31	0.35	0.40	4.62	2.40

Normalisation of DDF values

The results of the $tg\delta$ measurements (as presented in Tables 1 and 2) show that in some insulating zones with a small coefficient K_1 , the $tg\delta$ values are lower than 0.5 %, but calculating the $tg\delta$ for OIP yields several times higher values. This may indicate, for example, that insulation is not dry enough.

For normalisation of DDF values for the transformer insulation, limits for oil [4] and for solid insulating materials need to be used.

The DDF limits may be recommended at the temperature of 20 °C and are presented in Table 4.

If DDF calculation values for solid insulation exceed the limits or if there is a significant difference between the values for different insulating zones of the transformer, the reason for these changes must be investigated.

Conclusion

The suggested method to define coefficients K_1 and K_2 can be implemented during transformer manufacturing, at a repair shop or a place of installation.

The parameters of insulation are measured once for a typical transformer with oil and a typical transformer without oil, and the calculated coefficients K_1 and K_2 for the corresponding type of transformer can then be used to define DDF of solid insulation of similar transformers.

The use of uniform coefficients for recalculation of measured $tg\delta$

Recalculation of the measured DDF values at a given temperature to the base temperature performed using the uniform correction factor leads to a significant error

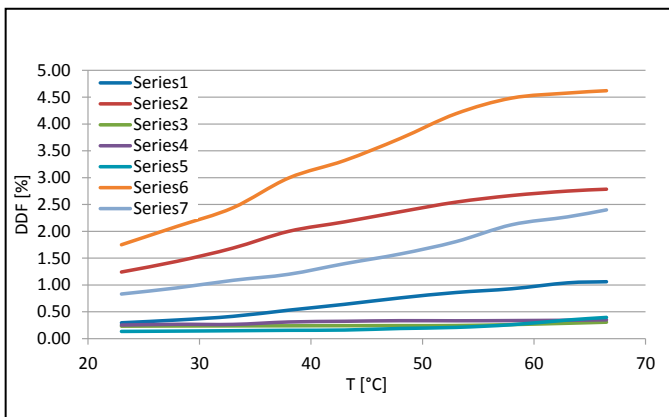

Figure 7. DDF (%) vs. temperature (°C) for different zones

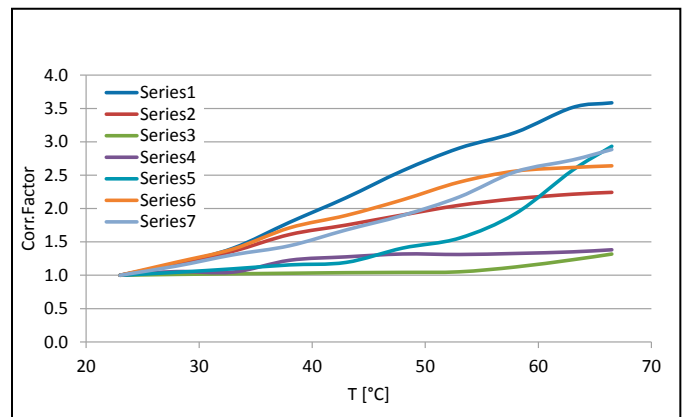

Figure 8. Correction factor vs. temperature (°C) for different zones

Table 4. DDF limits for oil impregnated cellulose materials

Condition of transformer	DDF (%) for oil-impregnated pressboard and paper	DDF (%) for laminated wood
New	0.6	1
In operation at the rated voltage		
Un ≤ 110 kV	1	1.5
110 kV < Un ≤ 170 kV	0.8	1.3
Un > 170 kV	0.7	1.2

values at a given temperature to base temperature leads to significant errors. To estimate the condition of the insulation, it is proposed to calculate the $tg\delta$ value of solid insulation for each elementary zone and compare it to the proposed limits.

Bibliography

- [1] IEEE Std. C57.12.90. *IEEE Standard Test Code for Liquid-Immersed Distribution, Power, and Regulating Transformers*
- [2] A.Shkolnik, *The Dielectric Dissipation Factor Method for Transformer Diagnosis*, D1-205, CIGRE 2006
- [3] A.Shkolnik. *The Normalization of the Dielectric Dissipation Factor Method for Transformer Insulation*, D1-214, CIGRE 2008
- [4] IEC 60422, *Mineral Insulating Oil in Electrical Equipment*

Authors



Anatoly Shkolnik received his M.Sc. degree in electronic engineering (physics of dielectrics and semiconductors) from the Kiev Polytechnic University (Ukraine) in 1973 and a PhD in electrical engineering (electrical stations, electrical machines) from the Electric Power Research Institute (Moscow, Russia) in 1990. He has experience in production, repair, testing and diagnosis of the power and instrument transformers. Currently, he is a senior specialist of the Central Electrical Laboratory at the Israel Electric Corporation, and a member of CIGRE SC A2 (TRANSFORMERS).



Baoding Tianwei Baobian Electric Co., Ltd.
Tel: 0086-312-8630395
Fax: 0086-312-8630342
E-mail: im@btwgroup.com

North America
Contact: Sim Zhang
Tel: 001-(201)365-8273
E-mail: zhangpengyuan@btwgroup.com

India
Contact: Ma Gui (Mark)
Tel: 0091-9971663156
E-mail: magui@btwgroup.com

Southeast Asia
Contact: Wang Zhao
Tel: 0086-13933251921
E-mail: wangzho@btwgroup.com

Africa
Contact: Donald Li
Tel: 0027-792829509
E-mail: lixiaodong@btwgroup.com



The largest capacity for single phase product and highest voltage Autotransformer (1500MVA / 1000kV)



Web: www.btwgroup.com