

EUR 4816 e

COMMISSION OF THE EUROPEAN COMMUNITIES

IRRADIATION BEHAVIOUR OF UO_2 FUEL
RODS CONTAINING GADOLINIUM OXIDE
AS CONSUMABLE POISON

by

R. KLERSY, A. SCHÜRENKÄMPER,
O. SIMONI and K.H. SCHRADER

1972



Joint Nuclear Research Centre
Ispra Establishment - Italy

LEGAL NOTICE

This document was prepared under the sponsorship of the Commission of the European Communities.

Neither the Commission of the European Communities, its contractors nor any person acting on their behalf:

make any warranty or representation, express or implied, with respect to the accuracy, completeness, or usefulness of the information contained in this document, or that the use of any information, apparatus, method or process disclosed in this document may not infringe privately owned rights; or

assume any liability with respect to the use of, or for damages resulting from the use of any information, apparatus, method or process disclosed in this document.

This report is on sale at the addresses listed on cover page 4

at the price of B.Fr. 70.—

**Commission of the
European Communities**
D.G. XIII - C.I.D.
29, rue Aldringen
L u x e m b o u r g

October 1972

This document was reproduced on the basis of the best available copy.

EUR 4816 e

IRRADIATION BEHAVIOUR OF UO_2 FUEL RODS CONTAINING GADOLINIUM OXIDE AS CONSUMABLE POISON by R. KLERSY, A. SCHÜRENKÄMPER, O. SIMONI and K.H. SCHRADER

Commission of the European Communities
Joint Nuclear Research Centre - Ispra Establishment (Italy)
Luxembourg, October 1972 - 48 Pages - 24 Figures - B.Fr. 70.—

Eight UO_2 /SS fuel pins poisoned with Gd_2O_3 in form of molybdenum coated microspheres have been irradiated at burn-up values of 6 500, 9 400 and 14 000 MWD/T_U. The linear power was of about 500 W/cm and the central temperature of the fuel varied from 2 000 to 2 600° C.

Post-irradiation analysis showed that the molybdenum coated microspheres of Gd_2O_3 remain intact when the temperature of the fuel does not exceed 1 600 °C. Above this temperature the Mo-coating is progressively destroyed which results in the reaction between UO_2 and Gd_2O_3 . In the experiment no influence of burn-up on the behaviour of the microspheres could be observed.

EUR 4816 e

IRRADIATION BEHAVIOUR OF UO_2 FUEL RODS CONTAINING GADOLINIUM OXIDE AS CONSUMABLE POISON by R. KLERSY, A. SCHÜRENKÄMPER, O. SIMONI and K.H. SCHRADER

Commission of the European Communities
Joint Nuclear Research Centre - Ispra Establishment (Italy)
Luxembourg, October 1972 - 48 Pages - 24 Figures - B.Fr. 70.—

Eight UO_2 /SS fuel pins poisoned with Gd_2O_3 in form of molybdenum coated microspheres have been irradiated at burn-up values of 6 500, 9 400 and 14 000 MWD/T_U. The linear power was of about 500 W/cm and the central temperature of the fuel varied from 2 000 to 2 600° C.

Post-irradiation analysis showed that the molybdenum coated microspheres of Gd_2O_3 remain intact when the temperature of the fuel does not exceed 1 600 °C. Above this temperature the Mo-coating is progressively destroyed which results in the reaction between UO_2 and Gd_2O_3 . In the experiment no influence of burn-up on the behaviour of the microspheres could be observed.

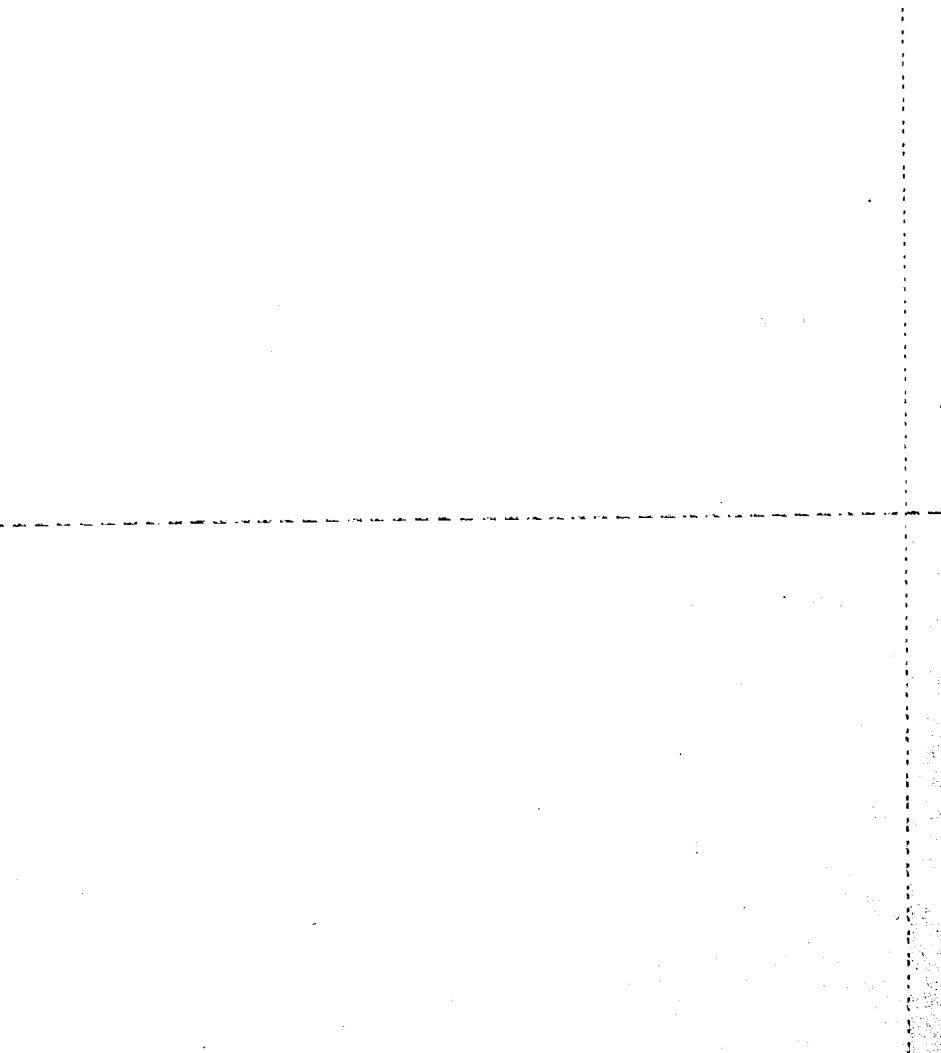

EUR 4816 e

COMMISSION OF THE EUROPEAN COMMUNITIES

**IRRADIATION BEHAVIOUR OF UO_2 FUEL
RODS CONTAINING GADOLINIUM OXIDE
AS CONSUMABLE POISON**

by

**R. KLERSY, A. SCHÜRENKÄMPER,
O. SIMONI and K.H. SCHRADER**

1972



ABSTRACT

Eight UO_2/SS fuel pins poisoned with Gd_2O_3 in form of molybdenum coated microspheres have been irradiated at burn-up values of 6 500, 9 400 and 14 000 MWD/TU . The linear power was of about 500 W/cm and the central temperature of the fuel varied from 2 000 to 2 600° C.

Post-irradiation analysis showed that the molybdenum coated microspheres of Gd_2O_3 remain intact when the temperature of the fuel does not exceed 1 600° C. Above this temperature the Mo-coating is progressively destroyed which results in the reaction between UO_2 and Gd_2O_3 . In the experiment no influence of burn-up on the behaviour of the microspheres could be observed.

KEYWORDS

FUEL PINS	COATING
URANIUM DIOXIDE	IRRADIATION
BURNABLE POISON	RADIATION EFFECTS
GADOLINIUM OXIDES	BURNUP
SPHERES	TEMPERATURE
MOLYBDENUM	CHEMICAL REACTIONS

C O N T E N T S *)

1. INTRODUCTION	7
2. DESCRIPTION OF THE EXPERIMENT	8
2.1. Irradiation facility	8
2.2. Test section	
2.3. Fuel rods	9
3. IRRADIATION	12
4. POST-IRRADIATION EXAMINATION	14
4.1. Gamma-scanning measurements	14
4.2. Fission gas release measurements	17
4.3. Dimensional measurements	21
4.4. Metallographic examination of fuel pellets.	21
5. CONCLUSION.	23

*) Manuscript received on March 10, 1972

LIST OF TABLES

- Table 1 : Characteristics of the fuel rods
- Table 2 : Poison charge in the fuel
- Table 3 : Irradiation conditions
- Table 4 : Irradiation times
- Table 5 : Power and calculated burn-up
- Table 6 : Puncture test
Gas analysis by mass-spectrometry
- Table 7 : Puncture test
Isotopic composition of fission gases.
- Table 8 : Fission gas release of the fuel rods 1 C and 2 C.

LISTE OF ILLUSTRATIONS

- Fig. 1 : Section through the reactor vessel
- Fig. 2 : Test section assembly
- Fig. 3 : Fuel assembly
- Fig. 4 : Cross-section of the fuel rod
- Fig. 5 : Components of a standard fuel rod
- Fig. 6 : Fuel rods 1 A and 1 B after assembly
- Fig. 7 : Poison distribution in the UO_2 pellets
- Fig. 8 : Radial temperature distribution in the fuel
- Fig. 9 : Gamma-scanning equipment
- Fig. 10 : Gamma-scanning measurements, rod 1 C
- Fig. 11 : Gamma-scanning measurements, rod 2 C
- Fig. 12 : Gamma-scanning measurements, rod 1 A
- Fig. 13 : Gamma-scanning measurements, rod 3 A
- Fig. 14 : Typical gamma spectrum
- Fig. 15 : Gamma spectrum measured on the lower end of the fuel rod 3 A
- Fig. 16 : Metallographic aspect of microspheres in different radial positions of the fuel rod 1 C
- Fig. 17 : Metallographic aspect of microspheres in different radial positions of the fuel rod 3 B
- Fig. 18 : Metallographic aspect of microspheres in different radial positions of the fuel rod 3 A
- Fig. 19 : Macrographic and micrographic aspect of a deformed microsphere in the columnar grain zone of UO_2
- Fig. 20 : Macrographic and micrographic aspect of a deformed microsphere in the columnar grain zone of UO_2

Fig. 21 : View of an intact microsphere near the surface
of the UO_2 pellet

Fig. 22 : View of a microsphere located at the boundary
of the columnar grain zone

Fig. 23 : Reaction between UO_2 and Gd_2O_3 in different sections
of a microsphere

Fig. 24 : Influence of temperature and burn-up on the integrity
of the microspheres.

1. INTRODUCTION

It has been assest that the addition to reactor fuels of parasitic neutron-capturing elements in small amounts may be of great advantage for the reactor design and control.

The depletion of these elements, usually designated as burnable poisons, during the reactor operation compensates for reactivity losses due to fuel depletion and accumulation of stable fission products.

The main advantages wich could be obtained through the use of burnable poisons are [1] : extension of reactor endurance, improved core performance through better flux factors, and reduced mechanical control of the reactor. The concentration and the geometrical shape of burnable poison must be calculated such that its consumption rate follows the fuel depletion and that no poison residue remains at the end of the reactor core life.

These requirements could be satisfied by the use of self-shielded poisons consisting of microspheres of different diameters wich should be burned completely at the end of the core life-time.

In the frame of a program sponsered by EURATOM, Fiat Nucleare and Ansaldo * for the development of a naval reactor, the use of burnable poison has been considered of particular advantage, mainly for reasons of reactor control. Therefore a development program of fuel elements containing burnable poisons has been undertaken. Fiat Nucleare has **developed** a technique of preparation of burnable poison consisting in microspheres of gadolinium oxide (Gd_2O_3) coated with a thin molybdenum layer wich acts as diffusion barrier between UO_2 and Gd_2O_3 . The microspheres are incorporated in the UO_2 powder and sintered together in form of fuel pellets [2].

* Contrat d'association EUR/C/3622/6/61. -

The scope of the present work was to investigate the irradiation behavior of fuel rods containing this type of burnable poison and especially the metallurgical behavior of the microspheres incorporated in the UO_2 fuel.

Nine fuel rods have been irradiated at a heat rating and at temperatures representative of the peak values in the naval reactor-core. The rods were assembled in three trefoils which reached three different burn-up values, in the range of 6.500 to 14.000 MWD/Tu. The concentration of burnable poison varied from 700 to 4.000 ppm, the diameter of the microspheres was of 300 and 500 microns. In addition some pellets contained burnable poisons in form of fine distributed powder.

2. DESCRIPTION OF THE EXPERIMENT

2.1. Irradiation facility

The test section, containing nine fuel rods, has been irradiated in the organic loop DIRCE, which is located in the central channel of the reactor ISPRA-1. The unperturbed thermal neutron flux (maximum axial) integrated between 0 and 0,58 eV is :

$$\phi_0 \text{ max.} = 1.2 \cdot 10^{14} \text{ n.cm}^{-2} \cdot \text{sec.}^{-1}$$

The schematic location of the in pile section inside the reactor channel is shown in fig. 1.

2.2. Test section

The test section, shown in fig. 2, consists of a fuel assembly suspended at a shielding plug.

The fuel assembly is composed of three ZR-2 fillers (A, B, C), each containing three fuel rods. The coolant flows within the annuli existing between the fuel rods and the fillers. The three fillers are connected through a screwed central rod, which can be operated at the head of the test section. With this system the three fillers can be discharged separately after different irradiation time, in order to obtain three different burn-ups. The three upper fuel rods are instrumented with two CR/Al thermocouples each on the sheath. One rod is instrumented with a W-Re thermocouple in the center of the fuel. A view of the fuel assembly is shown in figure 3. A more detailed description of the test section with the design data has been given in the irradiation proposal [3].

2.3. Fuel rods

The nine fuel rods have been denominated as follows :

- | | |
|-----------------|-----------------|
| - 1 A, 2 A, 3 A | upper trefoil |
| - 1 B, 2 B, 3 B | central trefoil |
| - 1 C, 2 C, 3 C | lower trefoil. |

The rods are similar except for the 1 A which is instrumented with a central thermocouple as shown in figure 4. Each rod consists of seven sintered UO_2 pellets S.S sheathed and closed by two S.S plugs TIG welded, with air filling.

The lower pellet is thermally insulated by an Al_2O_3 disc; a Nimonic 90 spring ensures the positioning of the fuel column. Figures 5 and 6 show fuel rods before and after assembly. In table 1 the main characteristic data for the fuel rods are listed.

Table 1 : Characteristics of the fuel rods

COMPONENT	PARAMETER	VALUE	UNIT
<u>SHEAT</u> (AISI 348)	Inner diameter	8.6 \pm 0.025	mm
	Thickness	0.6 \pm 0.03	mm
	Outer diameter	9.8 - 0.000 + 0.015	mm
<u>FUEL</u> sintered UO ₂ 11 W% enriched in U - 235	Standard pellet diameter	8.48 \pm 0.01	mm
	pellet diameter of rod* 1C	8.40 \pm 0.01	mm
	height of 1 pellet	13 \pm 0.25	mm
	UO ₂ density	93 \pm 94.5	% T.D
	surface rugosity	0.5 \pm 1.2	μ mm
<u>POISON</u> monoclinic Gd ₂ O ₃	density	97 \pm 99	% T.D

* The larger gap between fuel and sheath in the rod 1 C has been foreseen to reach a central temperature higher than the melting point of the Gd₂O₃.

The poisons have been mixed to the UO_2 powder in form of powder or in form of microspheres. The microspheres, obtained with the sol-gel method, are coated with a 30μ molybdenum layer in a fluidised bed [2].

The rod 1 A contains pure UO_2 with a central hole for thermocouple insertion.

The poison charge in the different fuel rods is described in table 2.

Table 2 : Poison charge

R O D	μ spheres diameter μ	Gd_2O_3 concentration ppm
2 A	500	1400
3 A	500	2100
1 B	powder	300
2 B	300	700
3 B	300	1200
1 C	powder	300
	500	4000
2 C	300	700
3 C	500	1400

Fig. 7 shows the poison distribution inside the UO_2 pellet. The detailed description of fuel rods fabrication and characteristics has been given in reference [4].

3. IRRADIATION

The test section has been irradiated during 6 cycles of the reactor, under the conditions listed in table 3.

Table 3 : Irradiation conditions

Coolant in pile flow	:	$G = 8 \text{ m}^3/\text{h}$
Coolant average pressure	:	$\bar{P} = 10 \text{ kg/cm}^2$
Coolant velocity	:	$V = 9,5 \text{ m/sec.}$
Coolant inlet temperature	:	$T_i = 280^\circ\text{C}$
Coolant outlet temperature	:	$T_o = 290^\circ\text{C}$
Measured sheath average temp. of the rods A	:	$\bar{T}_s = 430^\circ\text{C}$
Measured central temperature of the rod 1 A	:	$T_c = 2000^\circ\text{C}$

The three sets of fuel rods have been irradiated for different times as indicated in table 4.

Table 4 : Irradiation times

Fuel rods	A	B	C
Irradiation time (days)	135.2	81.9	59.5

The experimental values of sheath and fuel temperature and of power (determined by thermal balance) were in agreement within 5% with the design data. In table 5 are listed the power and the calculated burn-up for the different rods.

Table 5 : Power and calculated burn-up

	A	B	C
Specific thermal power (average radial and axial) w/gru	96	105	100
Linear power (average axial) w/cm.	500	546	515
Specific fission power w/gru	105	115	110
Calculated Burn-up MWD/Tu	14000	109400	6500

In fig. 8 the temperature distribution inside the fuel for the different fuel rods is shown.

N.B. : The six sheath-thermocouples have worked satisfactorily for the whole irradiation period. A very good performance was also given by the central T.C. of the rod 1 A, in W-Re, which has worked for 70 days at 2.000°C, with 30 thermal cycles.

4. POST-IRRADIATION EXAMINATION

The post-irradiation examination included the following operations :

- gamma scanning of fuel elements
- determination of fission gas release
- dimensional measurements of fuel elements
- metallographic investigation of fuel pellets.

4.1. Gamma-scanning measurements

The used apparatus consists of a mechanical part installed inside the hot cell (fig. 9), a collimator system mounted in the concrete wall of the cell and the equipment for γ -ray analysis outside the cell. An electronic control unit allows to run measurements automatically following a pre-selected program for the displacement of the fuel rod and for the counting time. In the described experiments the fuel rod rotating during counting was in a fixed position with regard to the axial direction. The used collimator has an aperture of 0.5 mm. height and 20 mm. width.

The total γ -activity in the energy range from about 50 KeV to 2500 KeV has been measured in steps of 0.5 mm. using a NaI-crystal.

The measurement of the γ -activity of some single isotopes has been carried out in steps of 5 mm. using a Ge-Li crystal. For the measurements of the rods 1 A and 3 A a steel shielding of 55 mm. thickness was placed between the fuel and the γ -ray detector in order to lower the very high γ -activity. Therefore in the following results the absolute values of the rods 1 C and 2 C can not be compared with the absolute values obtained for the rods 1 A and 3 A. The results of the γ -scanning measurements are reported in the figures 10 to 13.

The total γ -activity distribution is roughly representative for the thermal neutron flux distribution in the irradiation facility if one is not considering the increase of the flux at the end of the fuel stacks. Fuel rod 2 C with the lowest burn-up and the lowest irradiation temperature shows in some points an abrupt decrease of activity. These points correspond to the interfaces of two pellets with a dishing, which was originally present for each pellet. It cannot be observed for the rods 1 C, 1 A, 3 A. Temperature and irradiation effects have smoothed out the activity concentrations. In agreement with the irradiation conditions the profiles of the total activity of the rods 1 A and 3 A are very similar.

The activities of the single isotopes obtained with the Ge-Li crystal are plotted, too, in the figures 10-13. The values have been calculated from the corresponding peaks in the spectra. An example is given in fig. 14. The peak of the Nb 95 is not considered quantitatively, because it is not well separated from the Zr 95.

Due to the relatively short irradiation time only the Ru 103 and the Zr-95 could be measured for the fuel rods 1 C and 2 C. The activity distribution seems homogeneous over the whole length of the fuel stack in the case of the rod 2 C. Fuel rod 1 C shows an increase in activity near the upper end of the fuel, where the temperature was highest. Migration of the fission products may be the reason for this increase.

For the rods 1 A and 3 A also the Cs 137 could be measured, due to the higher burn-up. At the bottom of the fuel stack where the neutron flux and consequently the temperature were highest, a higher activity of Cs in comparison with the activities of Zr-95 and Ru 103 can be observed.

This is demonstrated very clearly with the spectra of the figures 14 and 15. Fig. 15 shows the spectrum measured on the lower end of the rod 1 A. There is a significant peak of the Cs 137 and the two peaks of the Cs 134 are recognized. The spectrum of the fig. 14 is a typical one for a measurement of the fission products inside the fuel stack. Only a small peak of the Cs 137 can be seen. The ratio between the quantity of Cs 137 and Zr-95 is much lower in the case of the spectrum of the fig. 15 than the corresponding of the fig. 14. Furthermore the fuel rods 1 A and 3 A show a rather high scattering of the Cs and Ru activities (Fig. 12 and 13). These observations indicate a migration of these isotopes inside the fuel.

4.2. Fission gas release measurements

The fuel rods 1 C and 2 C have been punctured under vacuum. Using a stepwise expansion of the fission gases released from the element into the vacuum system, samples for Kr-85 measurements (a known fraction of about 10^{-4} of the total quantity of gas) and for mass-spectrometric analysis (about 0.1 of the total quantity of gas) have been prepared.

Table 6 shows the composition of the gas samples measured by mass spectrometry. [It must be mentioned, that the capsules were filled originally with air. It cannot be excluded that some air entered in the flask of the rod 2 C during preparation of the gas sample. Therefore the value of 81.3 % may be too high, but it can be assumed that this has no influence on the determination of Kr and Xe].

The isotopic composition of the Kr and Xe of the gas samples is given in table 7. The measured values are nearly the same for the two rods. In the table there are also reported the theoretical compositions of the fission gases which are created during irradiation inside the fuel. There is a good agreement between these calculated values and the observed values for the released fission gases.

The amount of the released Kr-85 has been measured by γ -spectrometry. The spectrometer was calibrated with a known standard sample of Kr-85. Using these results and the mass spectrometric analysis of table 7 the amount of released fission gases have been calculated. Furthermore the total amount of the Kr and Xe created during irradiation have been determined by theoretical calculation. The results are compared in table 8 with the observed fission gas release. The fuel rod 1 C with the higher temperature shows a slightly higher gas release.

Table 6 : Puncture test
Gas analysis by mass-spectrometry

Gas	Quantity [%]	
	rod 1 C	rod 2 C
H ₂	3.8	1.7
He	0.6	0.3
Ar	0.1	0.1
Kr	3.2	2.3
Xe	22.3	14.3
Air	70.0	81.3

Table 7 : Puncture test. Isotopic composition of fission gases

Isotopes	Fission gas released		Fission gas created	
	rod 1 C	[%] rod 2 C	[%]	
Kr	83	14.0	14.3	14.1
	84	27.5	27.3	25.9
	85	7.1	7.1	7.5
	86	51.3	51.3	52.4
Xe	129	0.2	0.2	$1,7 \cdot 10^{-3}$
	130	0.1	0.1	$1,1 \cdot 10^{-3}$
	131	10.9	10.9	9.8
	132	17.7	17.3	16.8
	134	30.2	30.2	31.4
	136	40.9	41.3	41.8

Created quantity cm ³		Released quantity cm ³		Fraction released [%]
1 C : Kr	1.09	0.27		24.8
Xe	7.72	1.87		24.2
Kr + Xe	8.81	2.14		24.3
2 C : Kr	1.10	0.27		24.5
Xe	7.73	1.66		21.5
Kr + Xe	8.83	1.93		21.9

Table 8 : Fission gas release of the fuel rods 1 C and 2 C.

4.3. Dimensional measurements

The diameter of the fuel rods has been measured each 20 mm of length, in two angular positions. The measured values are all included in the range between 9,79 and 9,81 mm. From the comparison with the values before irradiation which varied from 9,800 mm to 9,815 mm it appears that the outer diameter of the fuel pins did not change during irradiation. Length measurements of the fuel pins showed no change due to the irradiation.

4.4. Metallographic examination of fuel pellets

The main objective of this experiment was to investigate the behavior of molybdenum coated microspheres of Gd_2O_3 in contact with the UO_2 , under irradiation. It is known that Gd_2O_3 reacts with UO_2 at temperatures above 1.500°C forming a solid solution over the entire composition range. The molybdenum coating should act as a diffusion barrier between UO_2 and Gd_2O_3 . An extensive metallographic investigation has been made on selected fuel pellets which differed by the burn-up, the central temperature, the concentration of Gd_2O_3 , and the diameter of the microspheres. Pellets containing burnable poison in form of powder were also examined. Longitudinal and transversal sections of the pellets have been prepared. By successive steps of polishing the Mo-coated microspheres of Gd_2O_3 distributed in the fuel pellets could be observed. The radial position of the observed microspheres has been measured with a low magnification optical microscope. Taking into consideration the radial temperature distribution in the pellets shown in fig. 8 it was possible to determine the mean irradiation temperature of the single microspheres.

Eighty-six sections from pellets of the fuel rods 3 A, 3 B, 1 C and 3 C have been polished and submitted to metallographic examination. A total number of about 72 microspheres could be observed in these fuel sections. Fig. 16 to 18 show the metallographic aspect of microspheres in function of their radial position in the fuel pellets for the elements 1 C, 3 B and 3 A. In the same figures the radial temperature distribution is indicated, which permits to determine for each microsphere its mean irradiation temperature. One can observe that the microspheres remained intact in the temperature range below 1.500 - 1.600°C. Above this temperature the molybdenum coating is more or less destroyed and the reaction between UO_2 and Gd_2O_3 takes place.

In most cases the spherical shape of the gadolinium oxide remains and one can assume that the self shielding effect of the poison spheres is not suppressed.

In some cases the microspheres are deformed when they are located in the zone of the columnar grains of the UO_2 . It may be that the mechanical deformation of the microspheres due to the grain growth of the UO_2 contributes to the rupture of the molybdenum coating.

Fig. 19 and 20 show two examples of deformed microspheres in the zone of the columnar grains of UO_2 .

Fig. 21 shows an example of an intact microsphere near the surface of the UO_2 pellet.

Fig. 22 shows a microsphere located at the limit of the columnar grain zone. The ondular appearance of the molybdenum surface seems to indicate the beginning of a reaction between the constituents. This effect results finally in the destruction of the coating with the subsequent reaction between the UO_2 and the Gd_2O_3 .

Fig. 23 illustrates this reaction in different sections of a microsphere. The porous zone in the different photographs could be considered as the reaction boundary. At this stage of the reaction a large number of small metallic inclusions (probably Mo) can be observed in the ceramic material. In order to illustrate the behaviour of the microspheres we have plotted in fig. 24 the total number of intact and defected microspheres in function of their irradiation temperature and of the burn-up of the fuel elements.

The influence of the temperature on the integrity of the microspheres appears very clearly in this figure, while the burn-up does not seem to have any influence.

5. CONCLUSION

The present experiment has demonstrated that the molybdenum coated microspheres of Gd_2O_3 incorporated into UO_2 pellets behave satisfactorily under irradiation until a temperature of about 1.500 to 1.600°C. Above this temperature the molybdenum coating is progressively destroyed with results in the reaction between the UO_2 and the Gd_2O_3 . No influence of burn-up on this effect could be detected, for burn-up values ranging from 6.500 MWD/ T_U to 14.000 MWD/ T_U .

ACKNOWLEDGEMENTS

The authors are grateful :

to G. Abate-Daga, I. Amato and D. Martorana (Fiat Nucleare) for their contribution to the definition of the experiment,

to J. De Greeff, N. Mariani, R. Pagani (CCR Ispra) and M. Ravizza (Fiat Nucleare) for the preparation of the irradiation experiment,

to G. Buscaglia, A. Frigo, E. Ghezzi, P. Knappik and A. Parisotto (CCR Ispra) for the post-irradiation analysis.

R E F E R E N C E S

- [1] A. RADKOVSKY :
- Theory and application of burnable poisons.
Peaceful uses of Atomic Energy.
Geneva 1958, Vol. 13.
- [2] G. ABATE-DAGA, I. AMATO, G. GRAPPIOLO :
- Nuclear fuel with burnable poison.
- Part. 1 :
- Gd₂O₃ microspheres preparation from the sol-gel method.
EUR 4550 e.
- Part. 2 :
- Preparation and out of pile evaluation of UO₂ pellets Gd₂O₃ poisoned.
EUR 4551 e.
- [3] R. KLERSY, O. SIMONI :
- DIRCE-005 - Proposta di irraggiamento di UO₂ contenente veleno consumabile (Gd₂O₃).
Comunicazione Euratom n° 2493 (1970).
(non available)
- [4] M. RAVIZZA, J. DE GREEFF, R. PAGANI, O. SIMONI :
- DIRCE-005 - Procedure di costruzione e collaudo di nove barre combustibili contenenti UO₂ e veleno consumabile (Gd₂O₃).
Comunicazione Euratom n° 2554 (1970).
(non available)

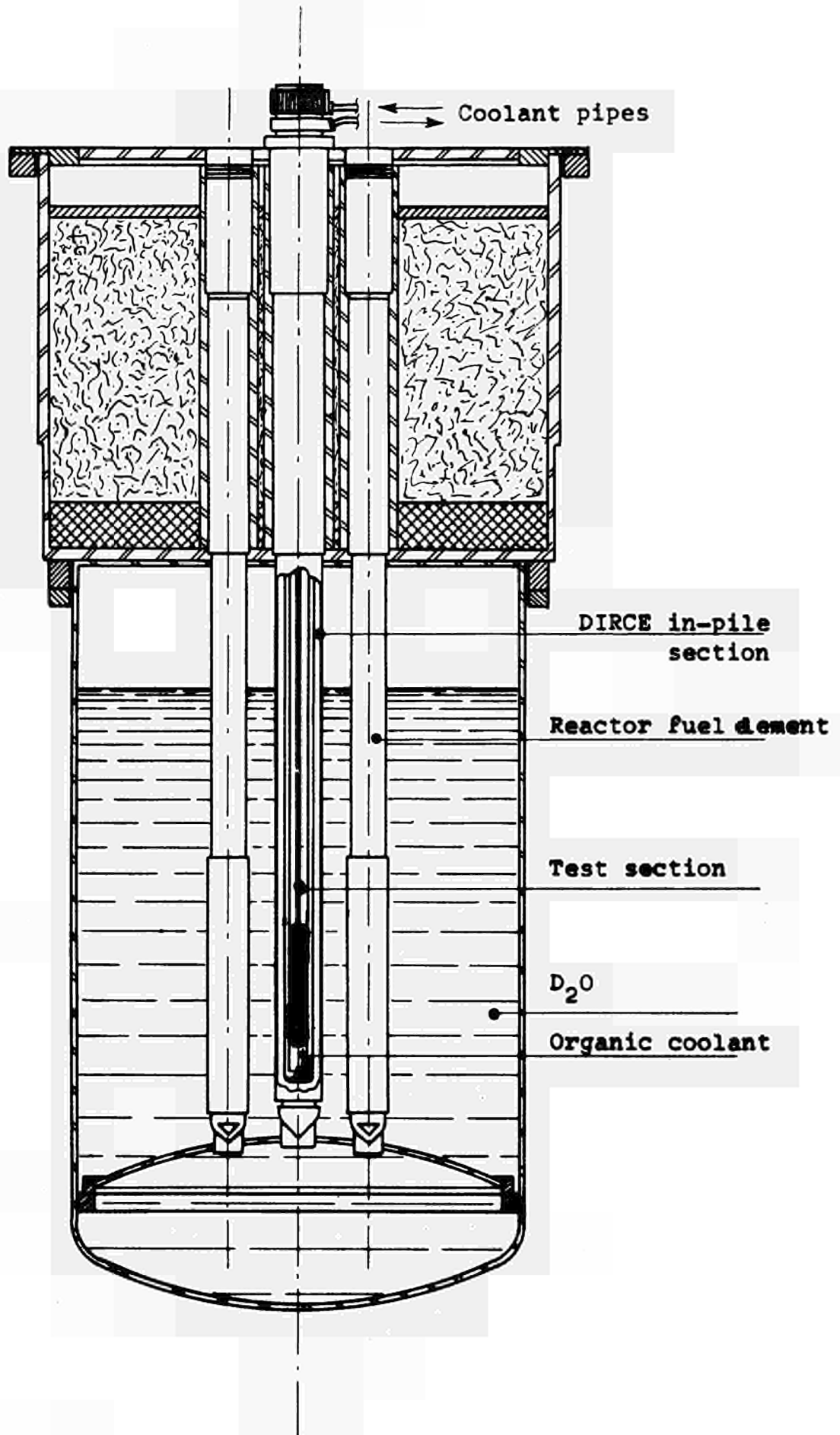

FIG. 1 - Section through the reactor vessel.

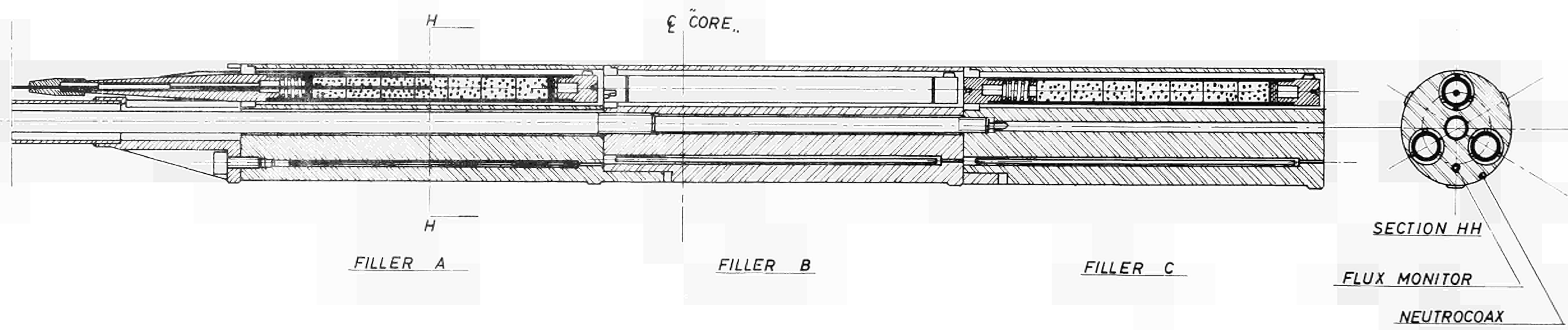
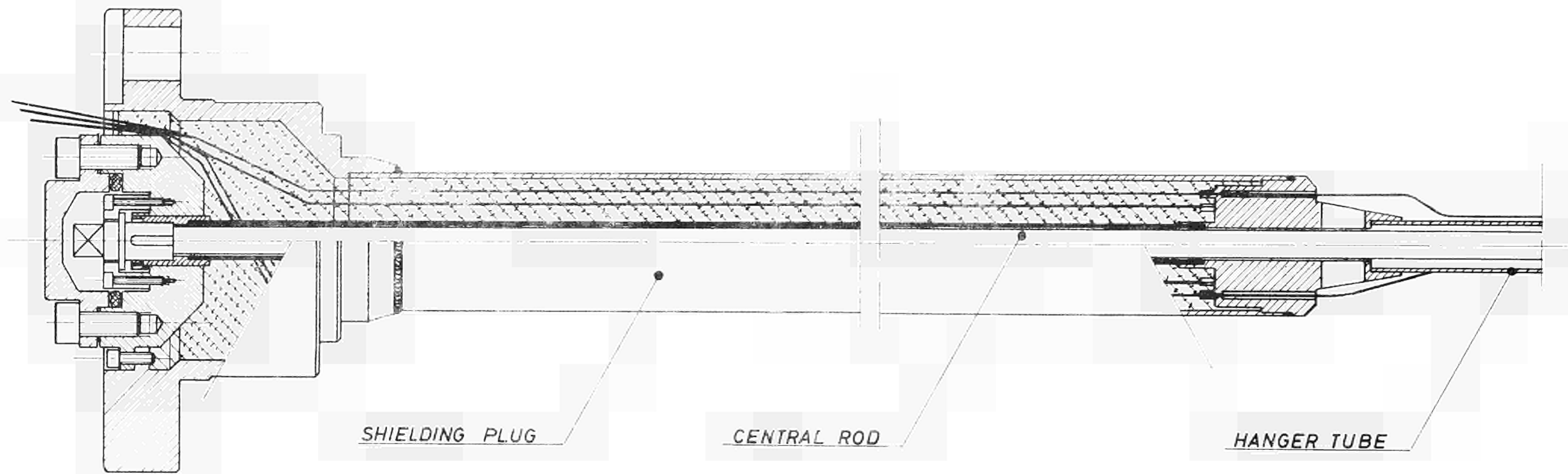

FIG. 2 TEST SECTION ASSEMBLY

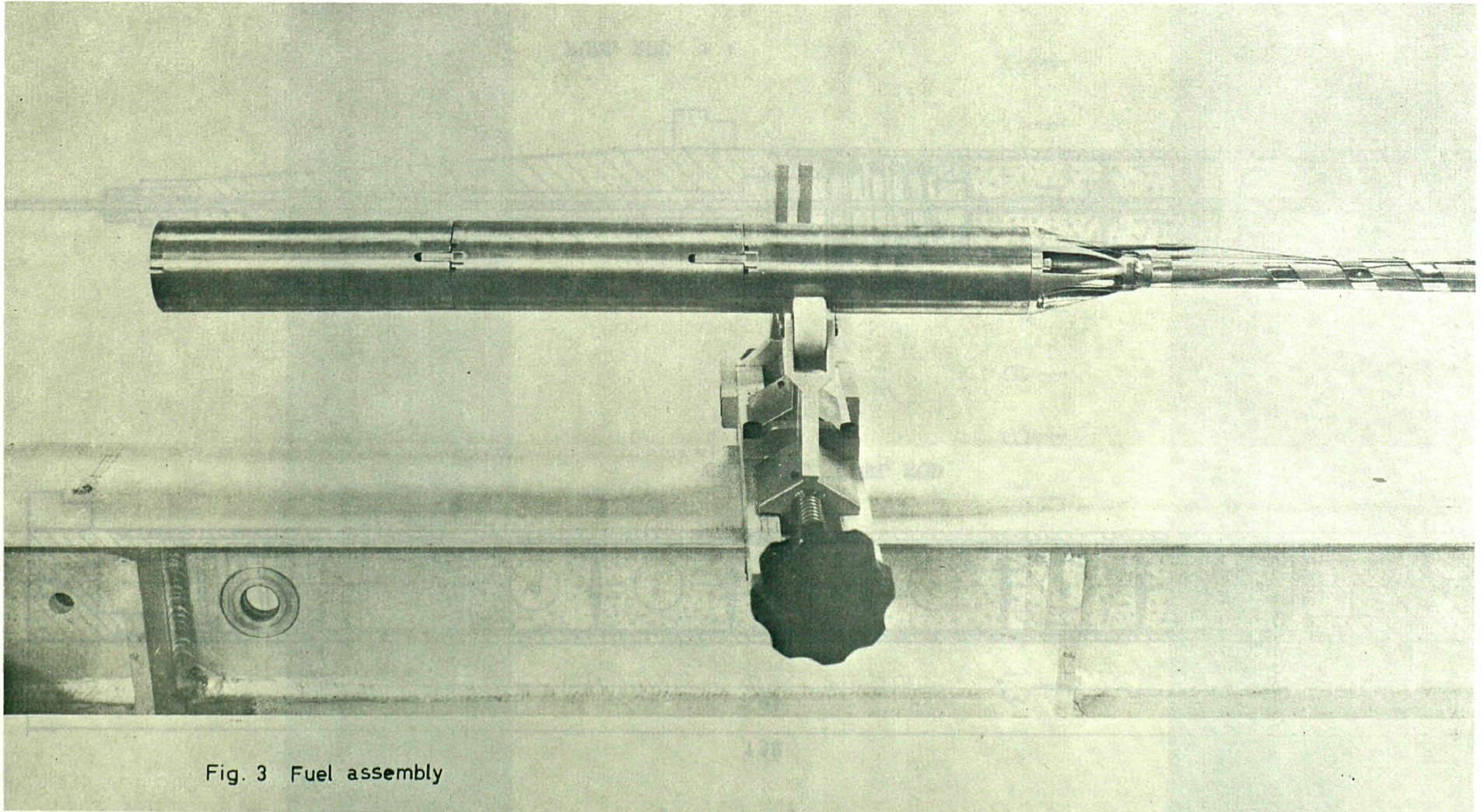
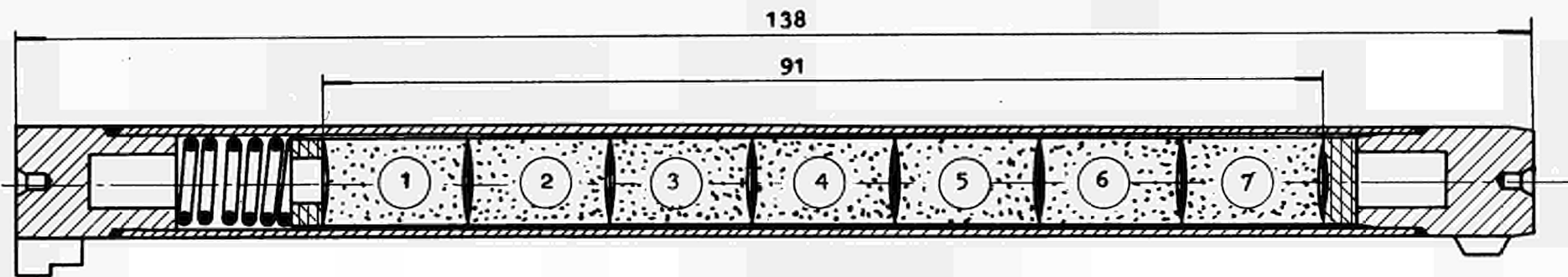
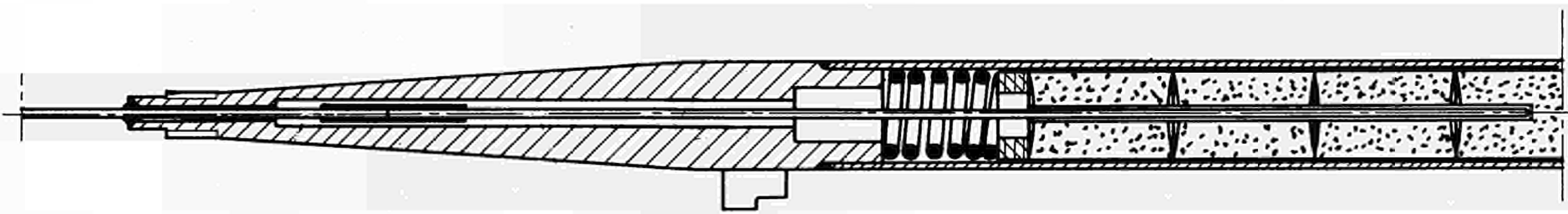

Fig. 3 Fuel assembly



STANDARD FUEL ROD



FUEL ROD 1 A

FIG. 4 - CROSS SECTION OF THE FUEL ROD

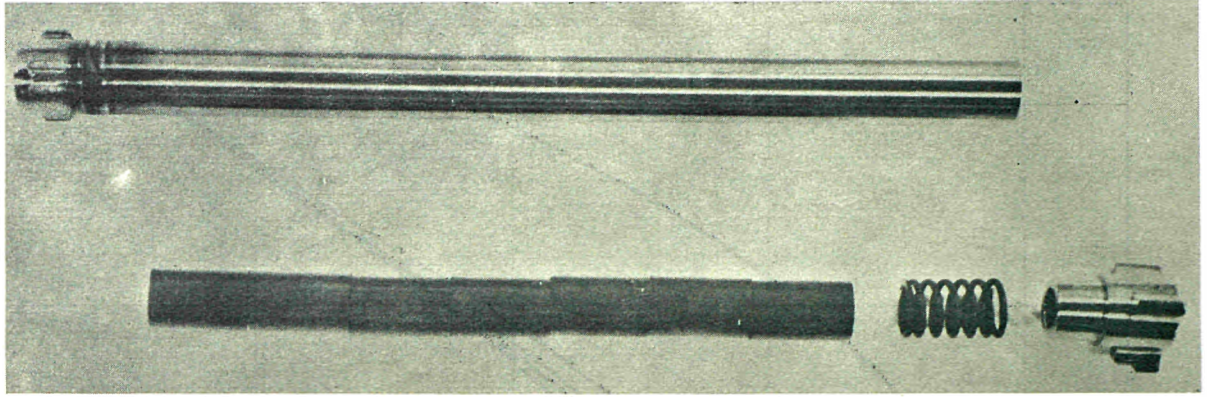

0 1 2 3 4 5 6 7 8 9 10 11 12 13

Fig.5-Components of a standard fuel rod

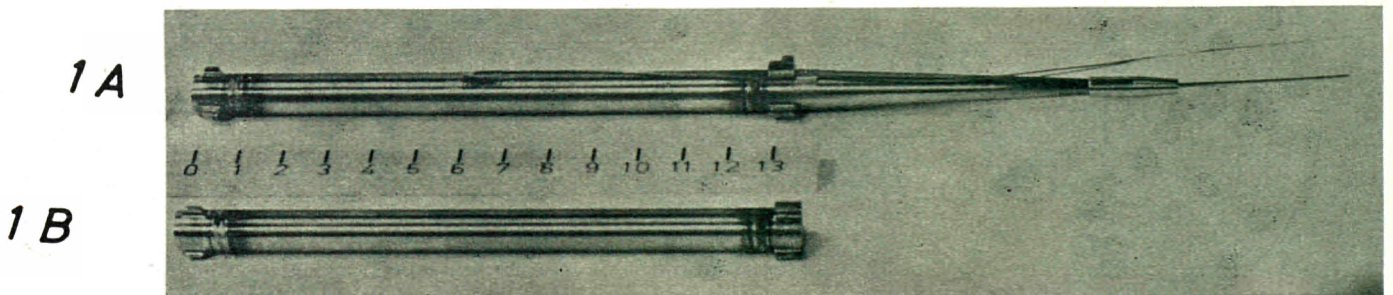

Fig.6-Fuel rods 1A and 1B after assembly

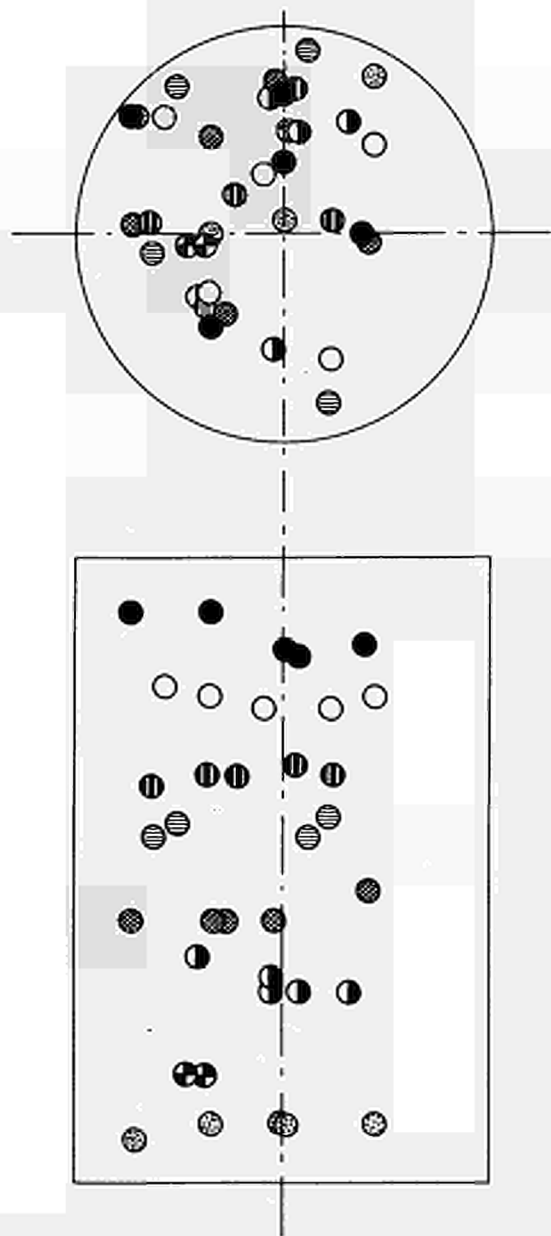

Fig.7- Poison distribution inside UO_2 pellet
(1200 ppm, $\phi = 300\mu$)

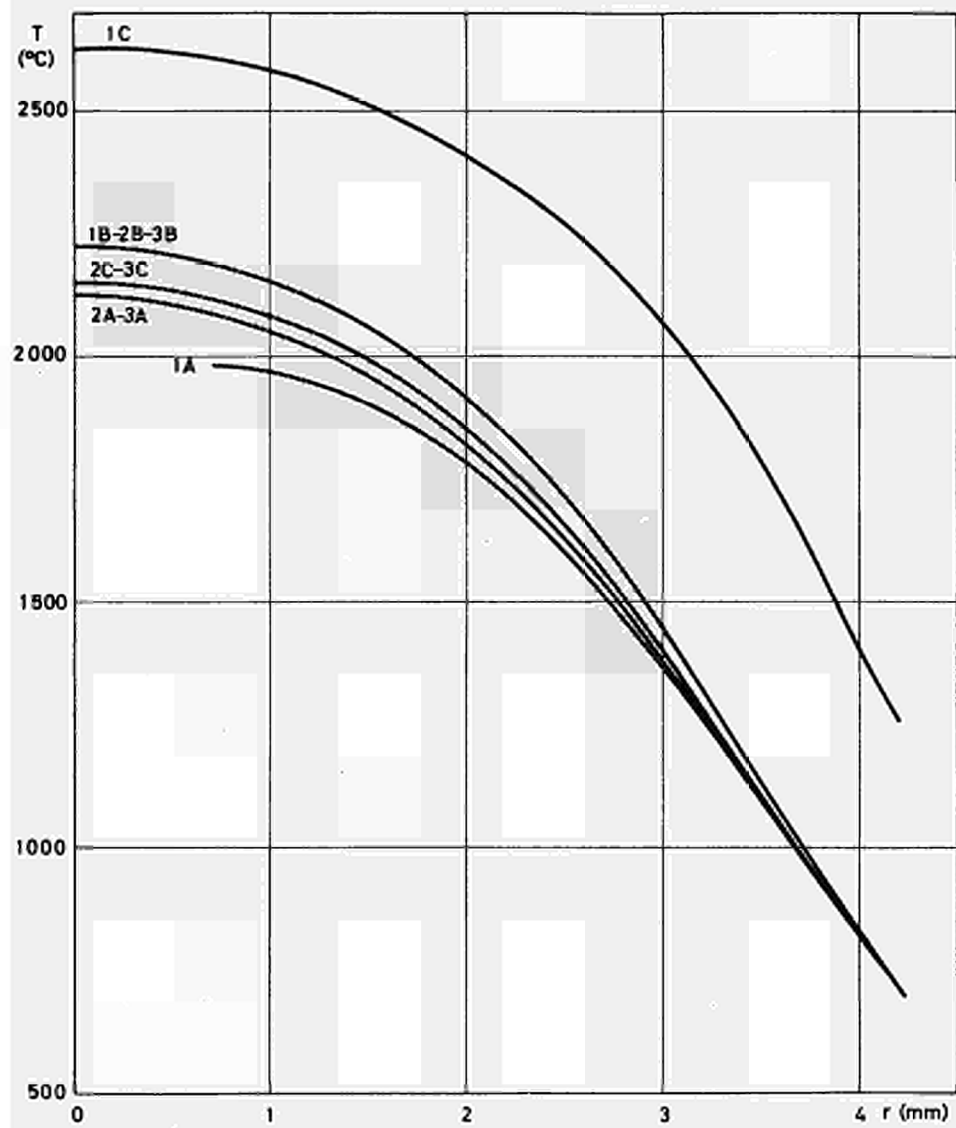

Fig.8- Radial temperature distribution
in the fuel

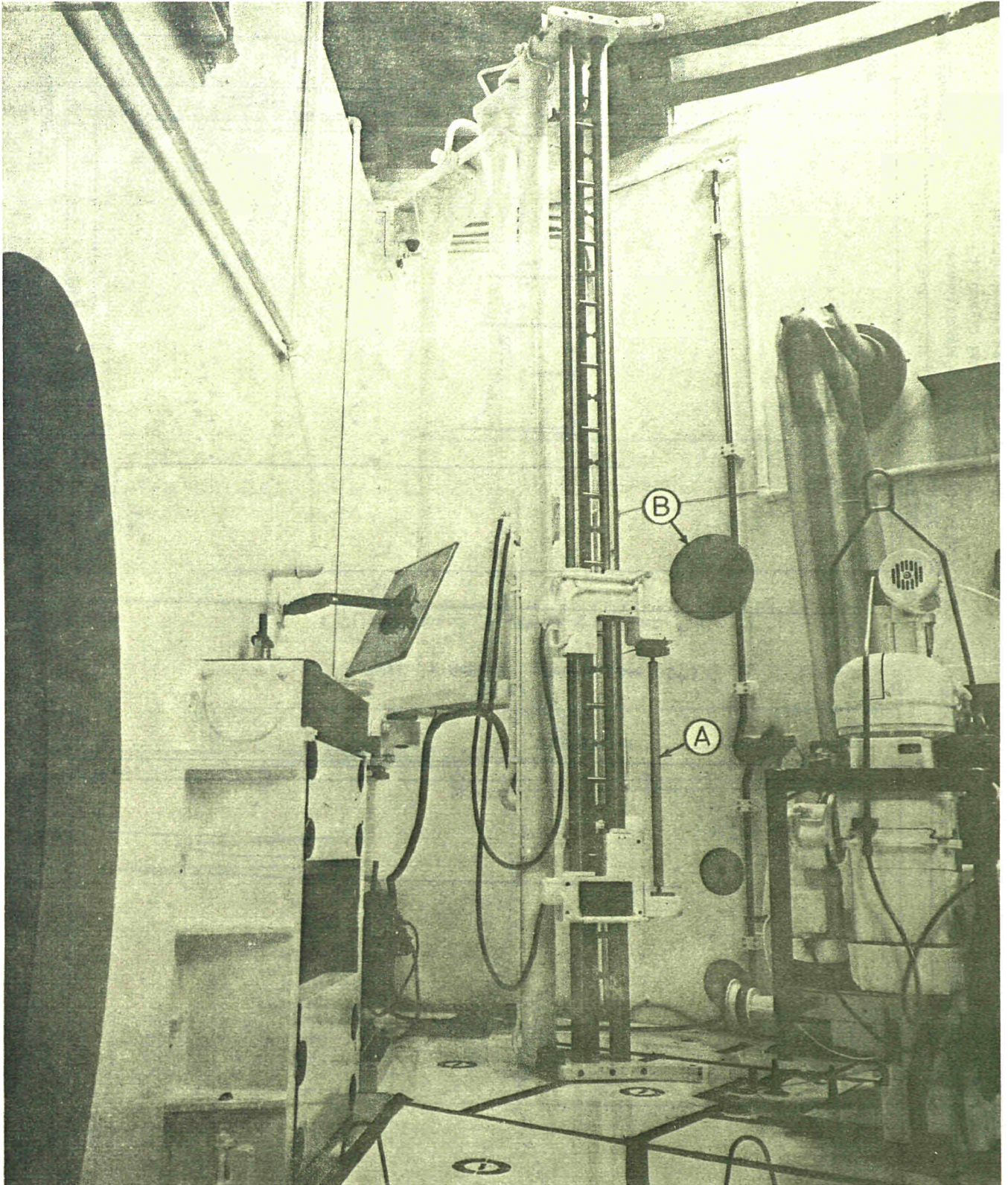

Fig.9 - Gamma-scanning equipment

A: fuel element
B: collimator

x Zr 95 - 724 KeV
 • Ru 103 - 497 KeV

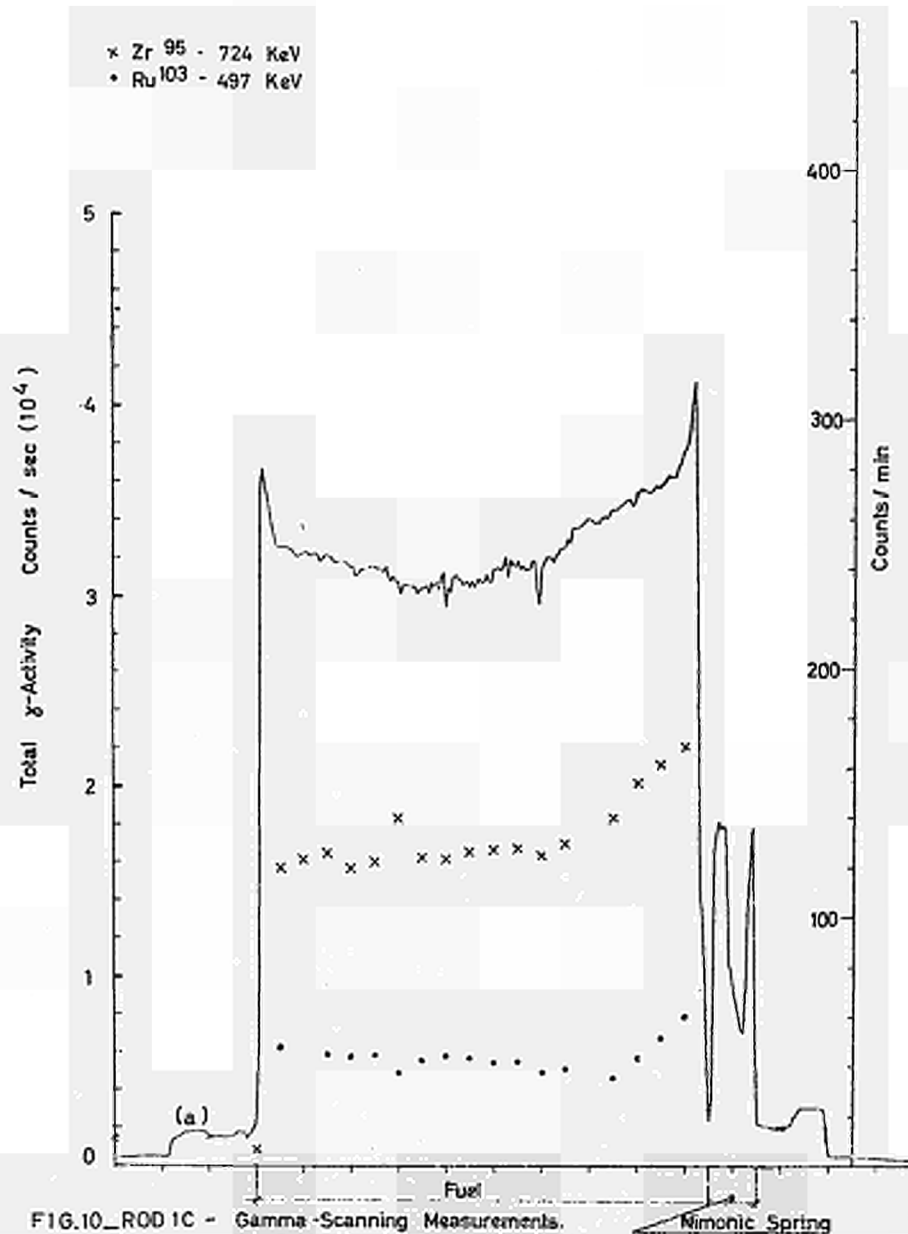

FIG.10 ROD 1C - Gamma-Scanning Measurements.
 Total Activity - NaI Crystal. (a)
 Activity of Isotopes - Ge-Li Crystal.

x Zr 95 - 724 KeV
 • Ru 103 - 497 KeV

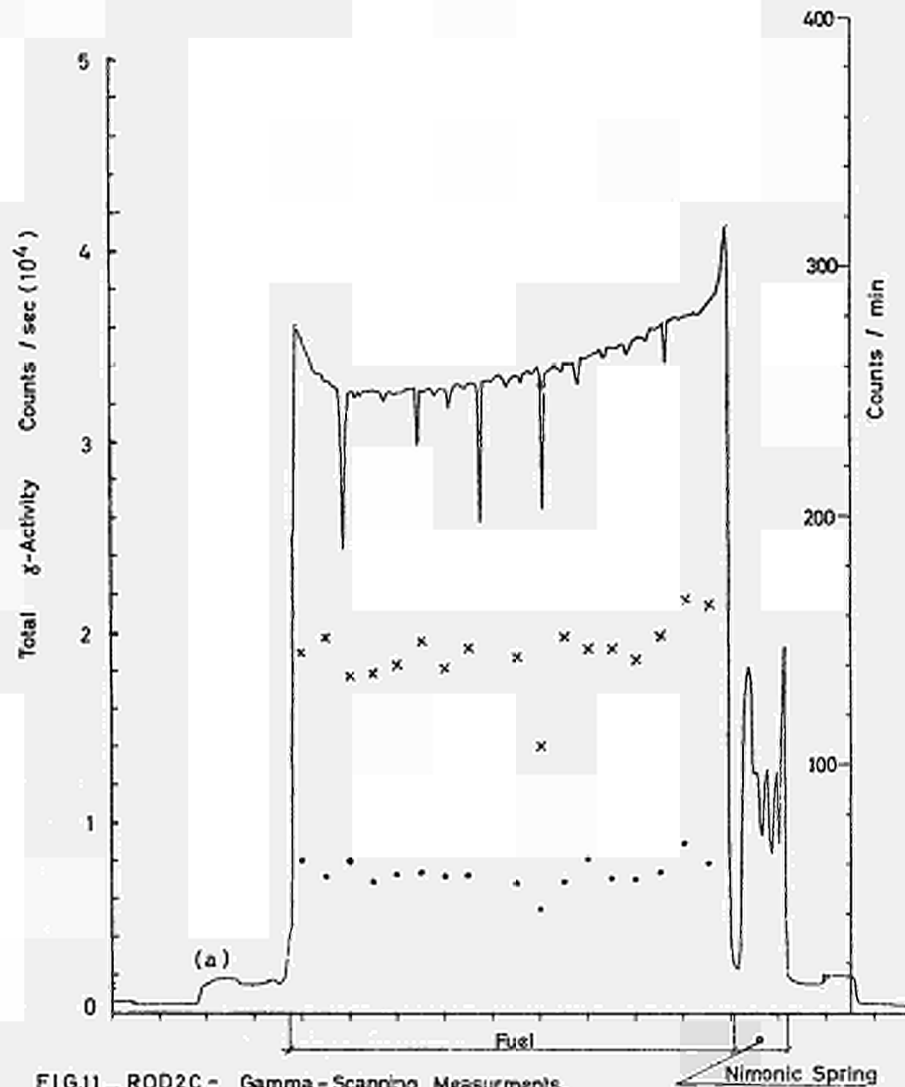
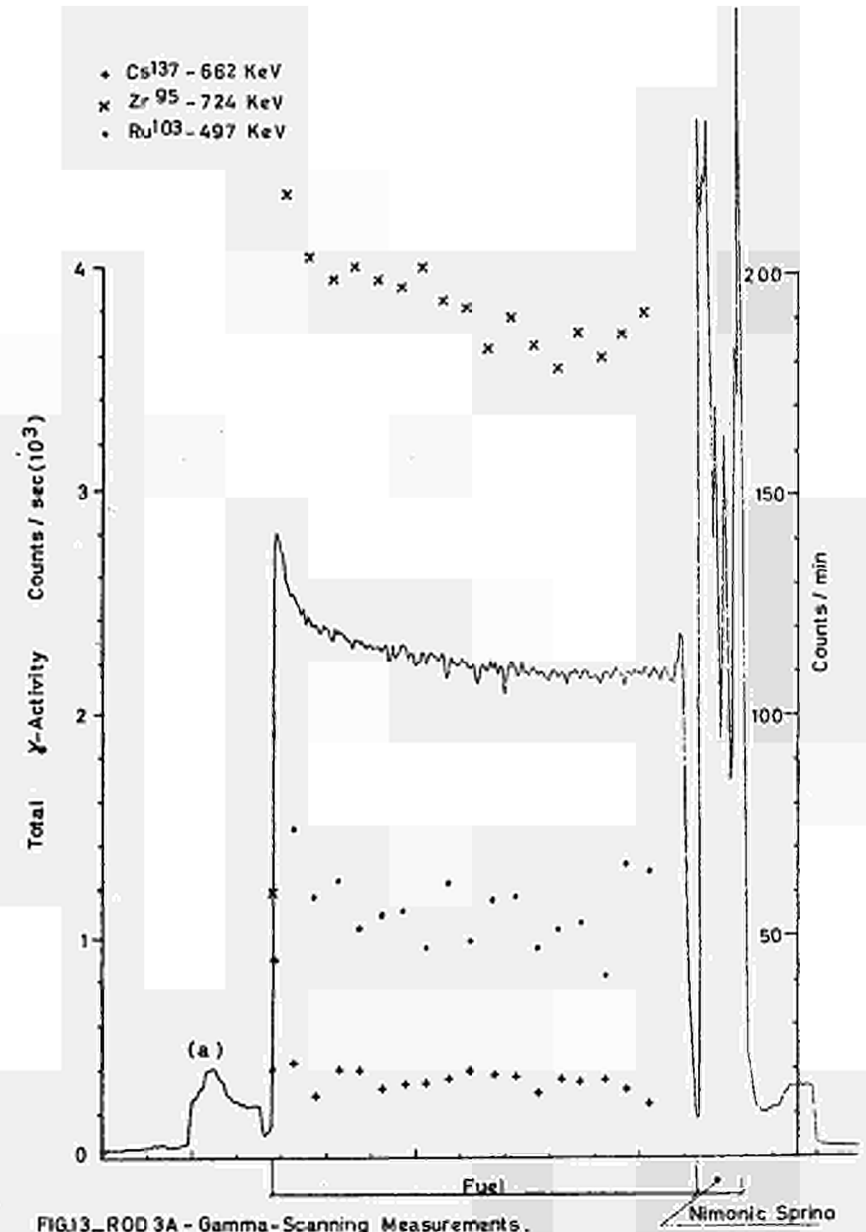
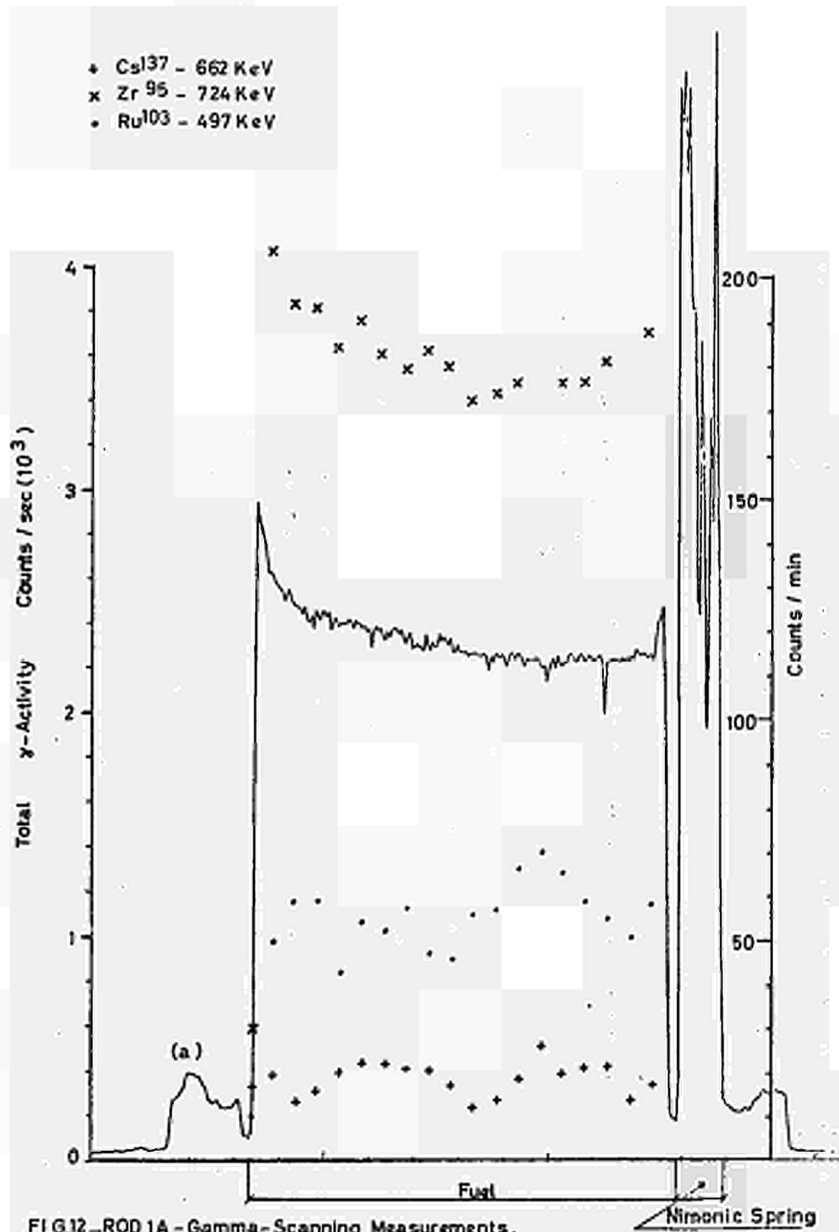

FIG.11 ROD 2C - Gamma-Scanning Measurements.
 Total Activity - NaI Crystal. (a)
 Activity of Isotopes - Ge-Li Crystal.



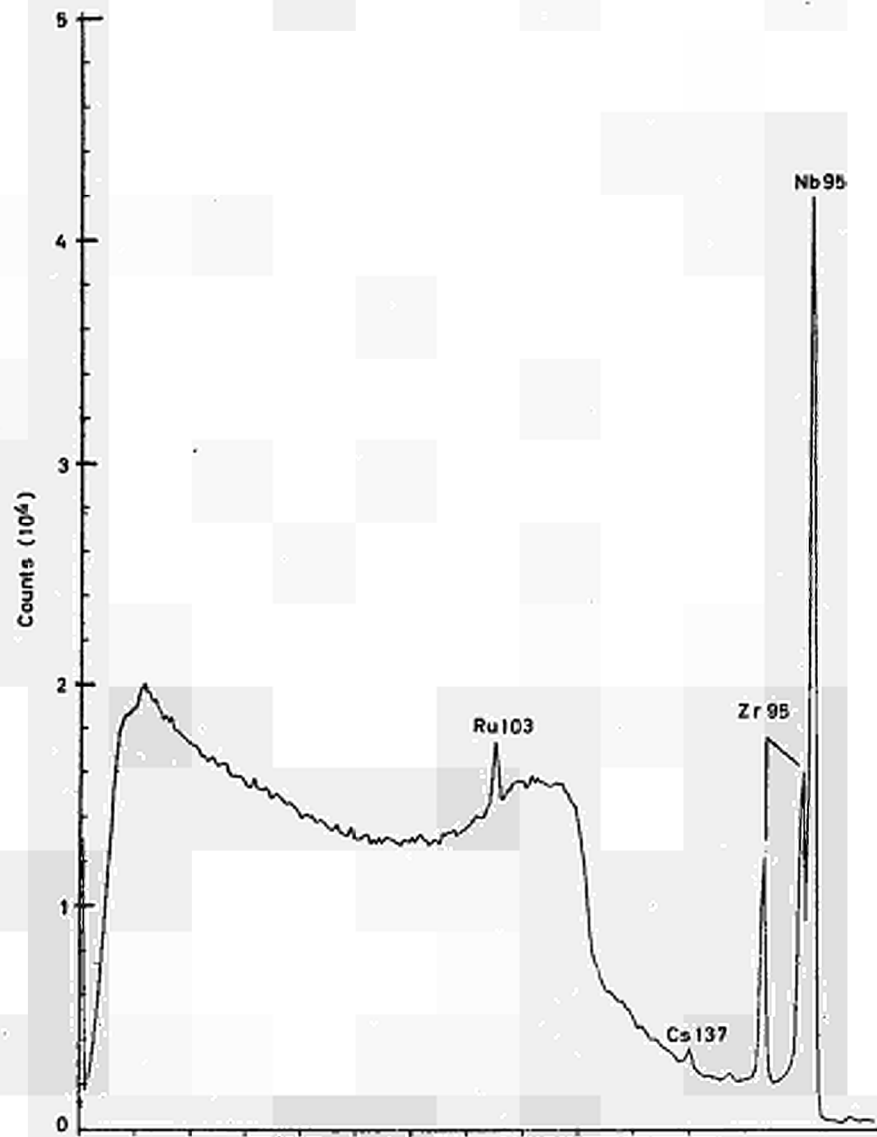

FIG.14 Typical γ -Spectrum rod 3A

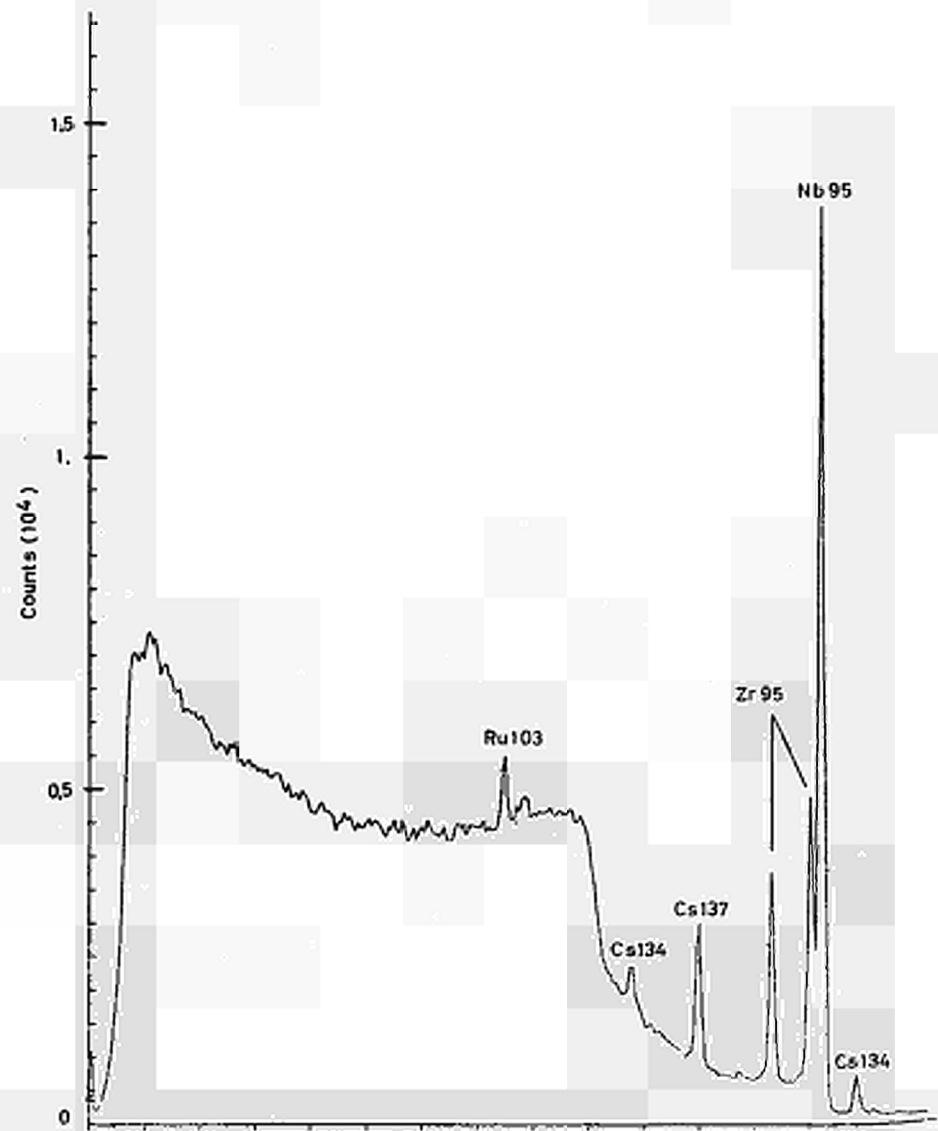

FIG.15 γ -Spectrum measured on the lower end of the fuel rod 3A

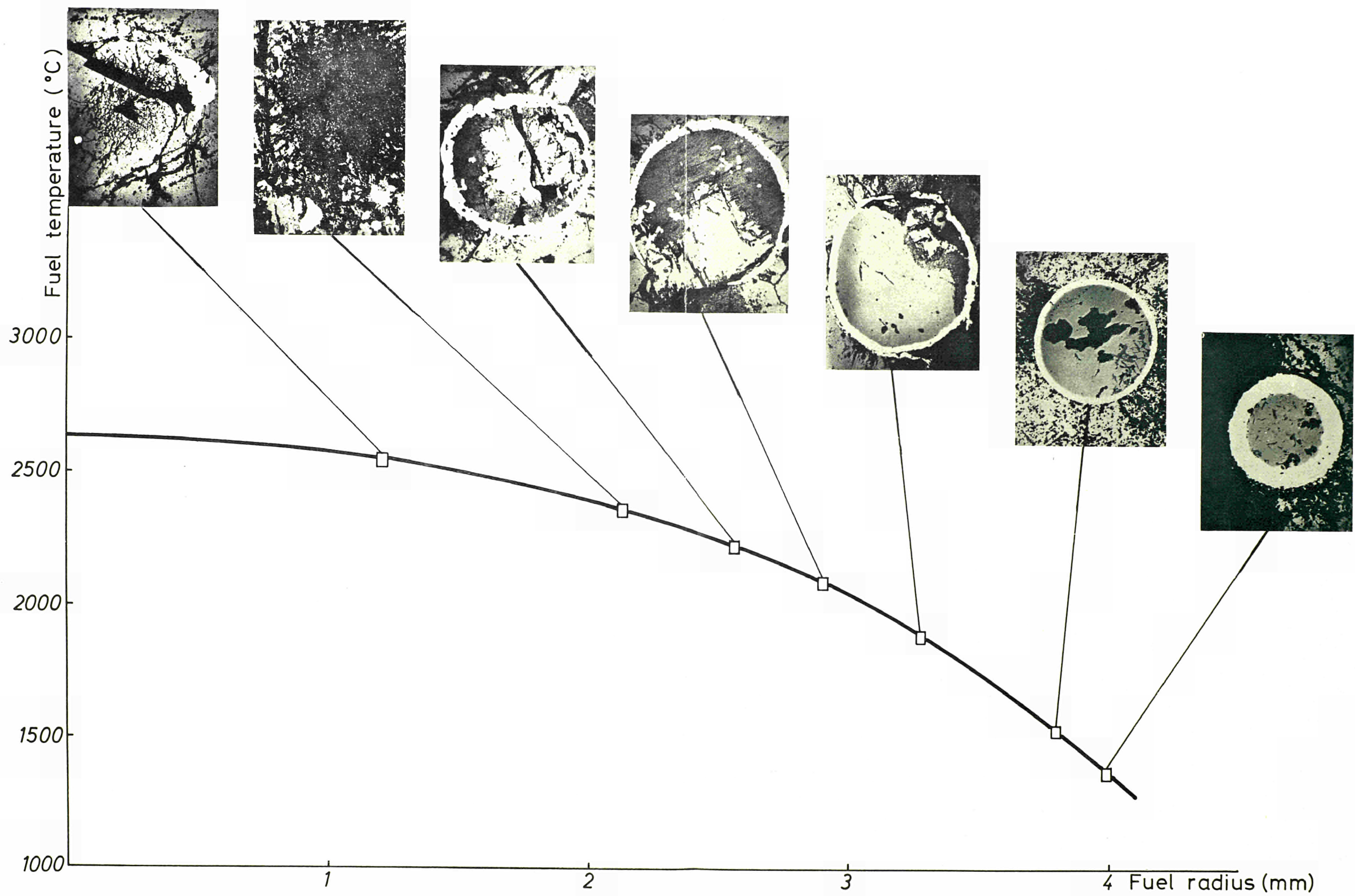

Fig: 16 Metallographic aspect of microspheres in different radial positions of the fuel rod 1C (b.up: 6500 MWD/T_U)
96 X

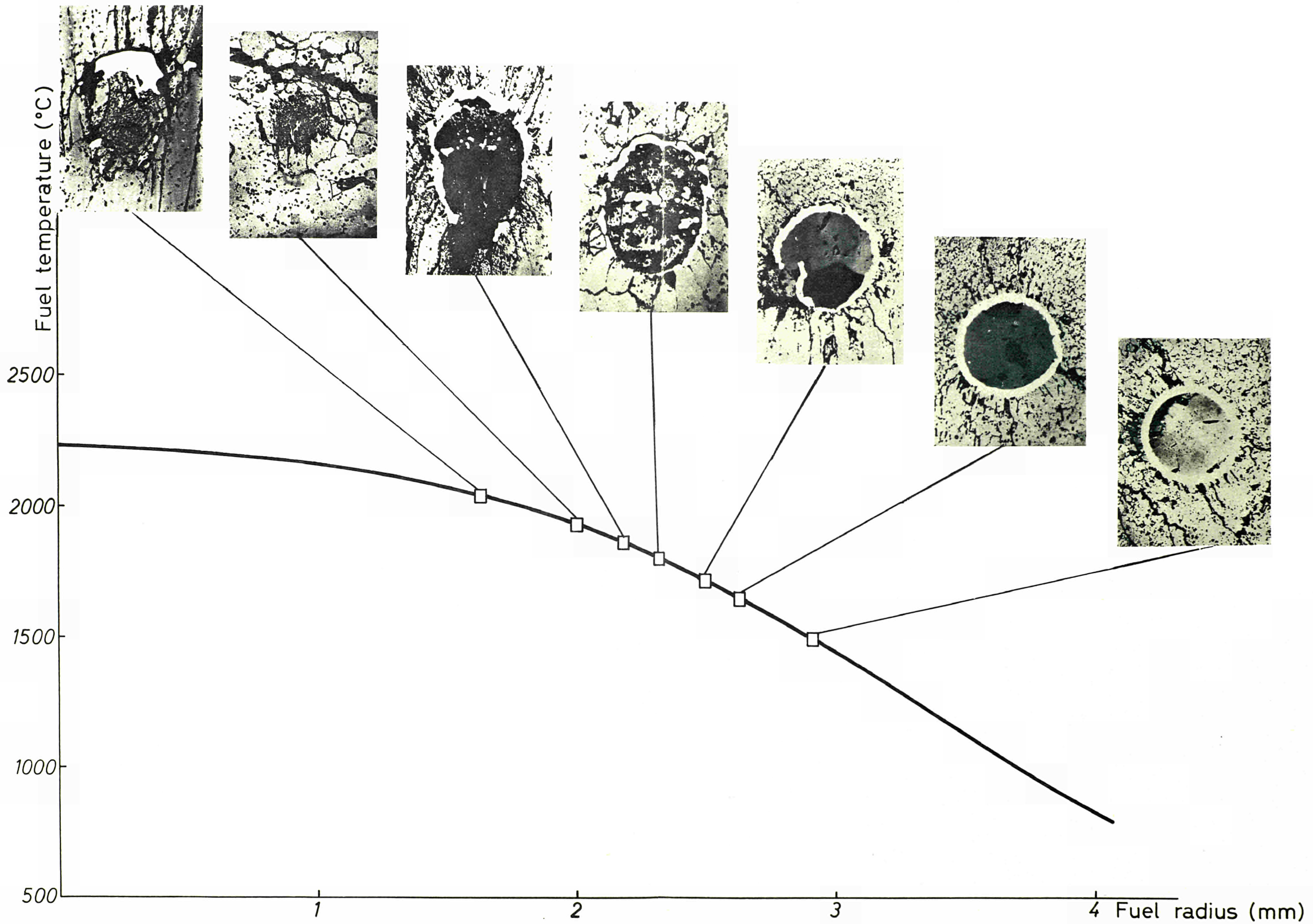

Fig: 17 Metallographic aspect of microspheres in different radial positions of the fuel rod 3B (b.up 9400 MWD/T_U)
96 X

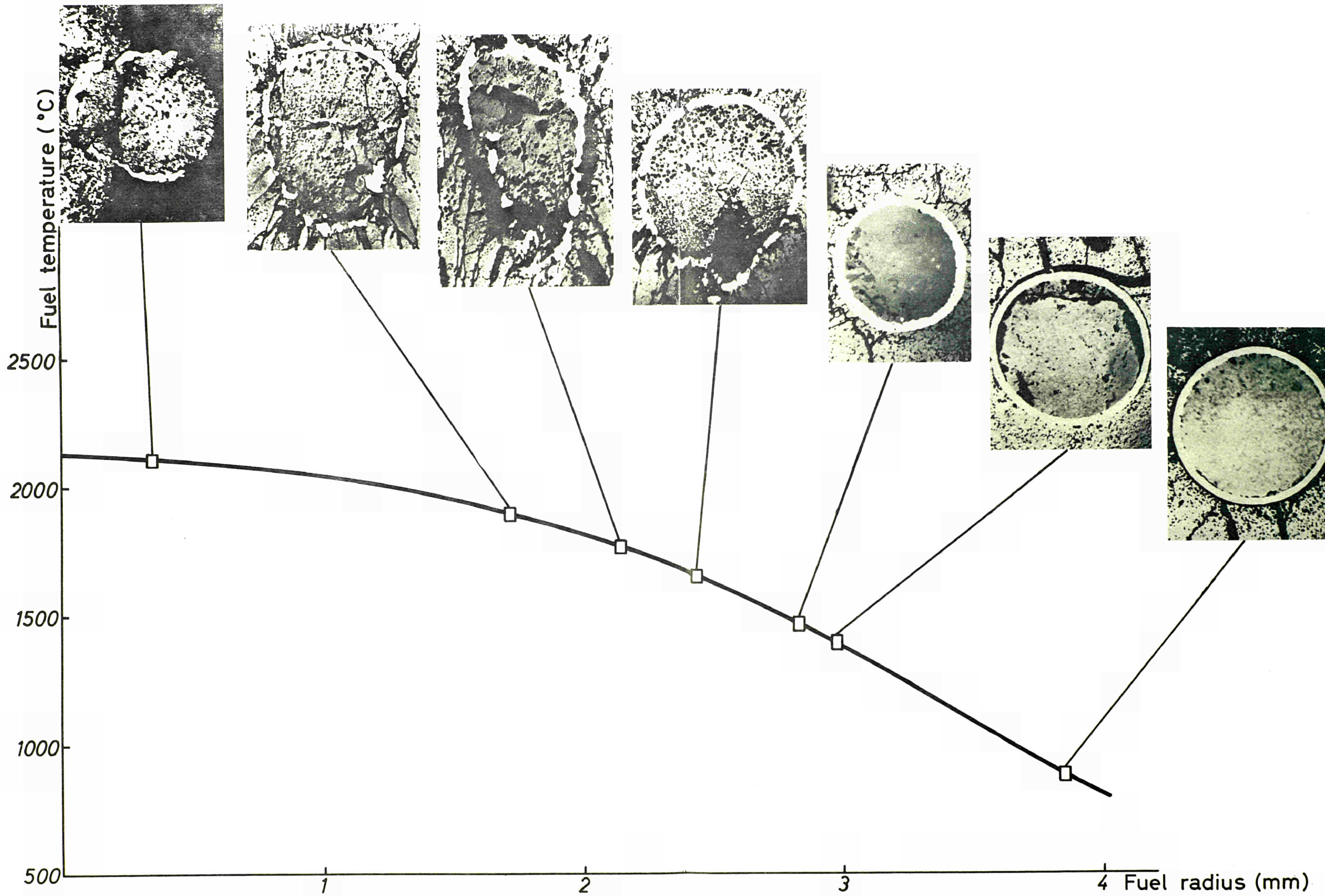
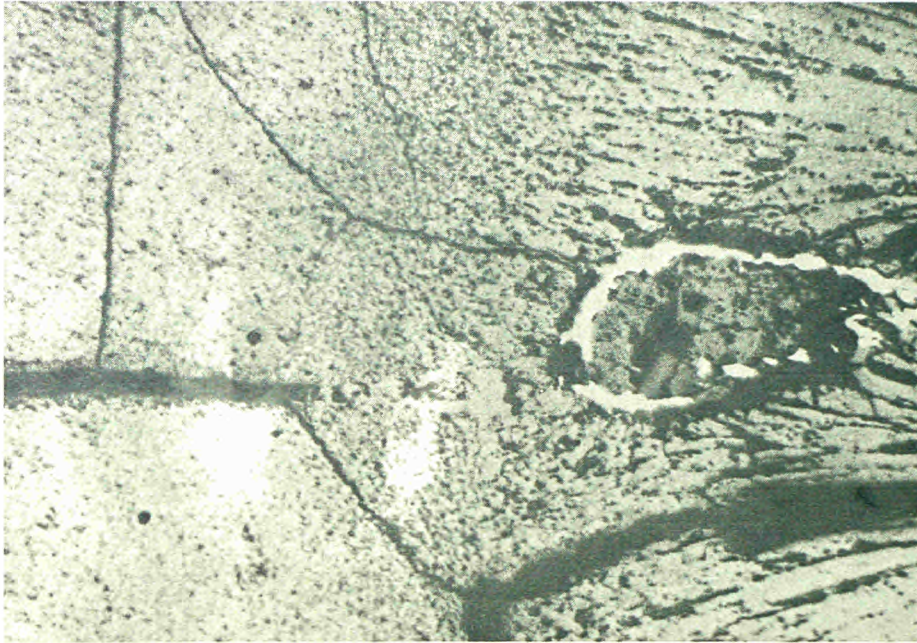
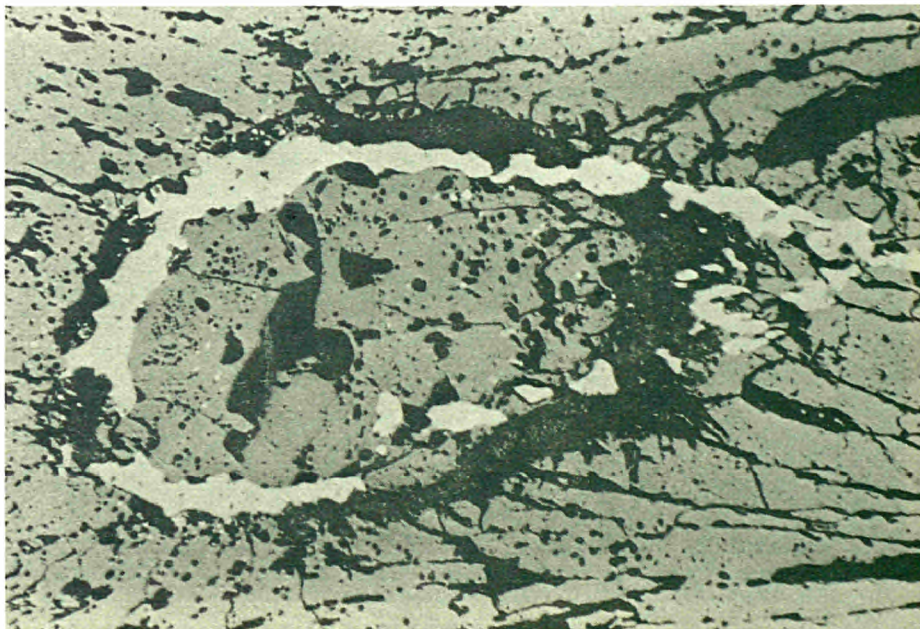

Fig:18 Metallographic aspect of microspheres in different radial positions of the fuel rod 3A (b.up 14000 MWD/T_U)
96 X





50 X



128 X

Fig. 19 : Macrographic and micrographic aspect of a deformed microsphere in the columnar grain zone of UO₂ (burn-up 14.000 MWD/T_U, temperature 1770°C).

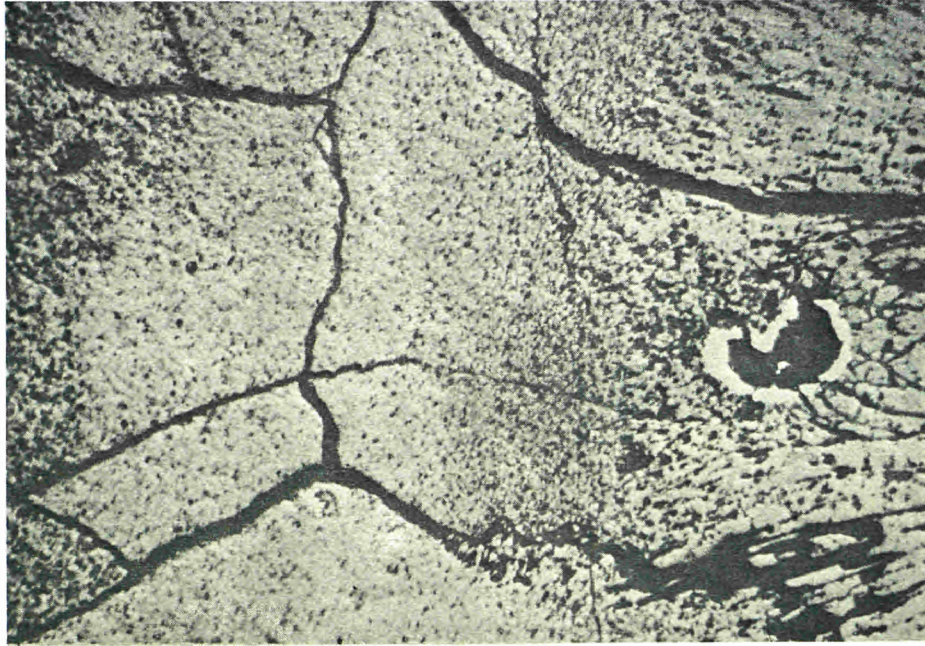

50 X

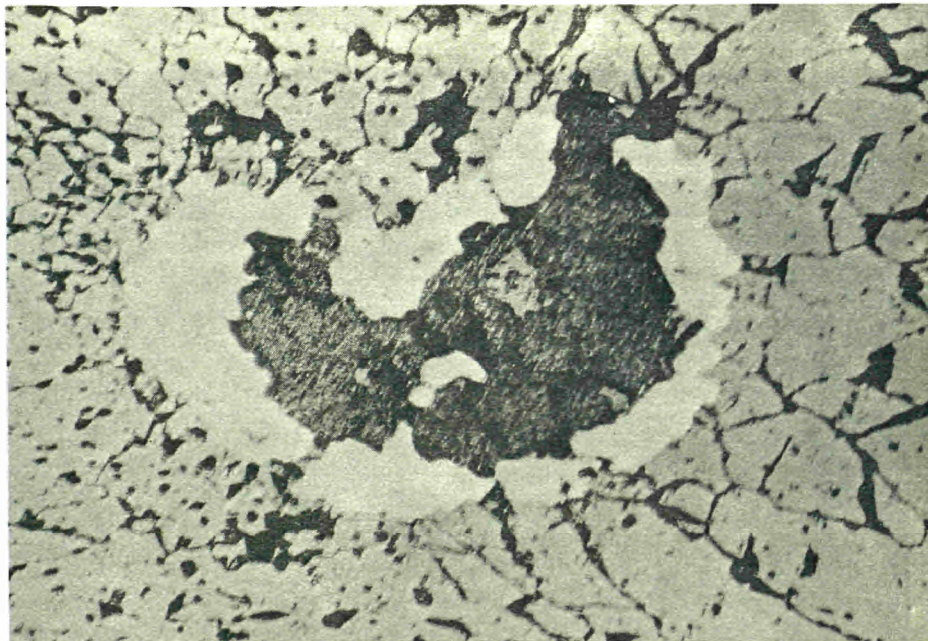

200 X

Fig. 20 : Macrographic and micrographic aspect of a deformed microsphere in the columnar grain zone of UO_2 (burn-up 14.000 MWD/ T_U , temperature 1730°C).

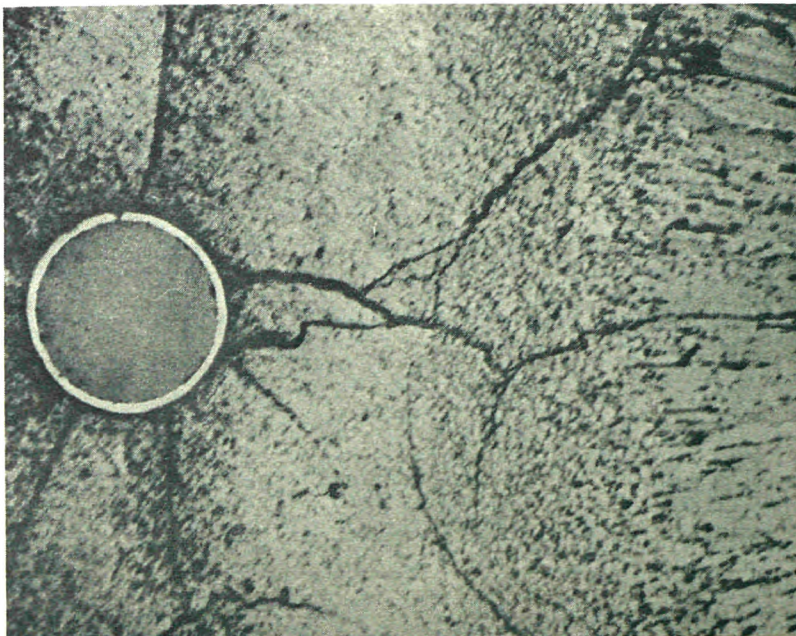

50 X

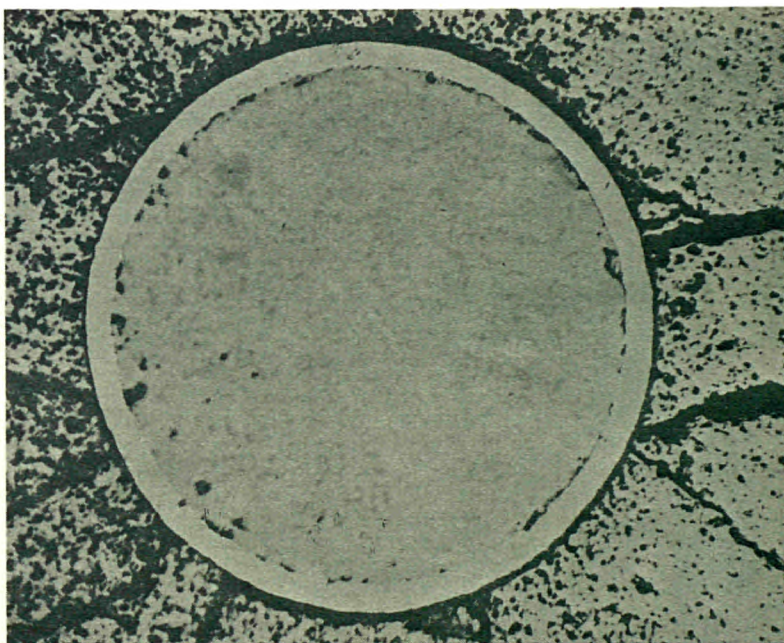

150 X

Fig. 21 : View of an intact microsphere near the surface of the UO_2 pellet (burn-up 14.000 MWD/T_U , irradiation temperature 890°C).

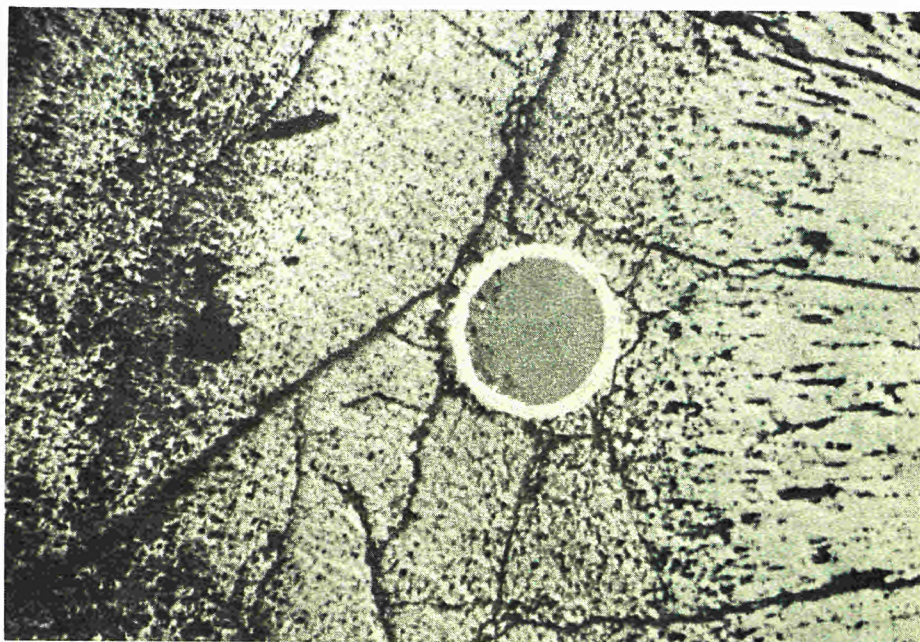

55 X

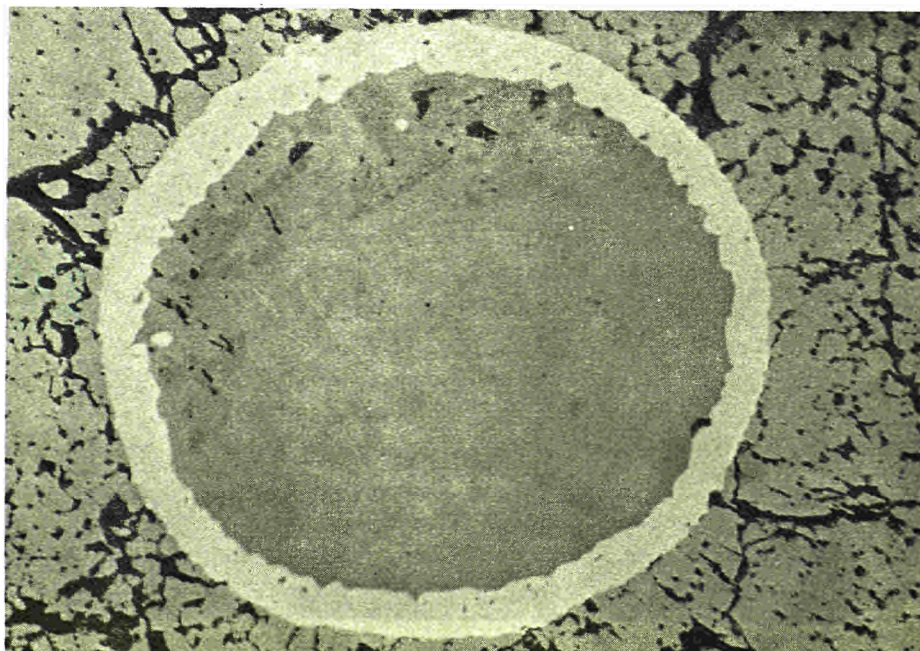

200 X

Fig. 22 : View of a microsphere located at the boundary of the columnar grain zone (burn-up 14.000 MWD/T_U, temperature 1460°C).

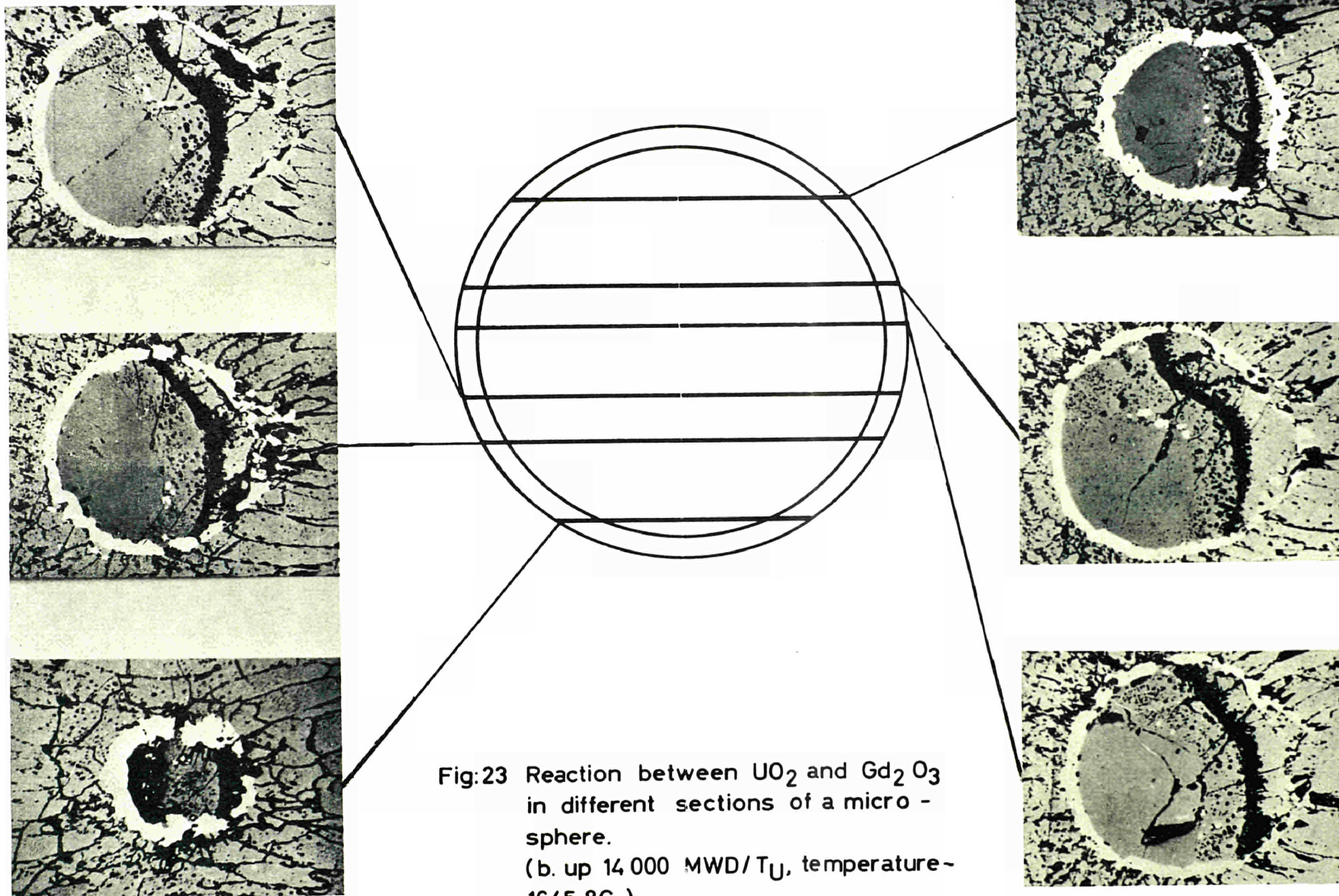

Fig:23 Reaction between UO_2 and Gd_2O_3 in different sections of a micro-sphere.
(b. up 14 000 MWD/ T_U , temperature - 1645 °C)

128 X

NOTICE TO THE READER

All scientific and technical reports published by the Commission of the European Communities are announced in the monthly periodical "euro-abstracts". For subscription (1 year: B.Fr. 1 025,—) or free specimen copies please write to:

Office for Official Publications
of the European Communities
Case postale 1003
Luxembourg 1
(Grand-Duchy of Luxembourg)

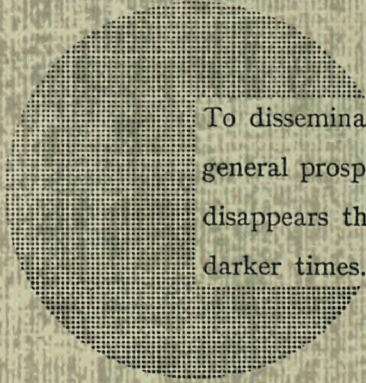

To disseminate knowledge is to disseminate prosperity — I mean general prosperity and not individual riches — and with prosperity disappears the greater part of the evil which is our heritage from darker times.

Alfred Nobel

SALES OFFICES

The Office for Official Publications sells all documents published by the Commission of the European Communities at the addresses listed below, at the price given on cover. When ordering, specify clearly the exact reference and the title of the document.

GREAT BRITAIN AND THE COMMONWEALTH

H.M. Stationery Office
P.O. Box 569
London S.E. 1

UNITED STATES OF AMERICA

European Community Information Service
2100 M Street, N.W.
Suite 707
Washington, D.C. 20 037

BELGIUM

Moniteur belge — Belgisch Staatsblad
Rue de Louvain 40-42 — Leuvenseweg 40-42
1000 Bruxelles — 1000 Brussel — Tel. 12 00 26
CCP 50-80 — Postgiro 50-80

Agency :
Librairie européenne — Europese Boekhandel
Rue de la Loi 244 — Wetstraat 244
1040 Bruxelles — 1040 Brussel

GRAND DUCHY OF LUXEMBOURG

*Office for official publications
of the European Communities*
Case postale 1003 — Luxembourg 1
and 29, rue Aldringen, Library
Tel. 4 79 41 — CCP 191-90
Compte courant bancaire : BIL 8-109/6003/200

FRANCE

*Service de vente en France des publications
des Communautés européennes*
26, rue Desaix
75 Paris-15^e — Tel. (1) 306.5100
CCP Paris 23-96

GERMANY (FR)

Verlag Bundesanzeiger
5 Köln 1 — Postfach 108 006
Tel. (0221) 21 03 48
Telex : Anzeiger Bonn 08 882 595
Postcheckkonto 834 00 Köln

ITALY

Libreria dello Stato
Piazza G. Verdi 10
00198 Roma — Tel. (6) 85 09
CCP 1/2640

Agencies :
00187 Roma — Via del Tritone 61/A e 61/B
00187 Roma — Via XX Settembre (Palazzo
Ministero delle finanze)
20121 Milano — Galleria Vittorio Emanuele 3
80121 Napoli — Via Chiaia 5
50129 Firenze — Via Cavour 46/R
16121 Genova — Via XII Ottobre 172
40125 Bologna — Strada Maggiore 23/A

NETHERLANDS

Staatsdrukkerij- en uitgeverijbedrijf
Christoffel Plantijnstraat
's-Gravenhage — Tel. (070) 81 45 11
Giro 425 300

IRELAND

Stationery Office
Beggar's Bush
Dublin 4

SWITZERLAND

Librairie Payot
6, rue Grenus
1211 Genève
CCP 12-236 Genève

SWEDEN

Librairie C.E. Fritze
2, Fredsgatan
Stockholm 16
Post Giro 193, Bank Giro 73/4015

SPAIN

Libreria Mundi-Prensa
Castello, 37
Madrid 1

OTHER COUNTRIES

*Sales Office for official publications
of the European Communities*
Case postale 1003 — Luxembourg 1
Tel. 4 79 41 — CCP 191-90
Compte courant bancaire ; BIL 8-109/6003/200