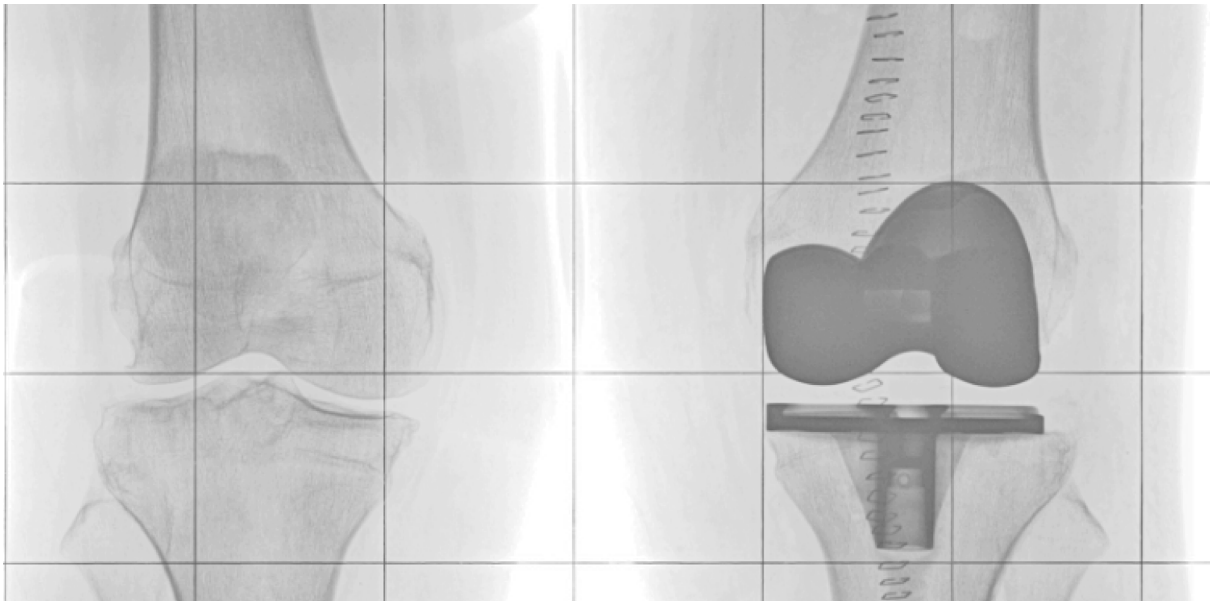


# THE TIBIO-FEMORAL JOINT LINE

*WHAT IS THE BIOMECHANICAL AND CLINICAL EFFECT OF SURGICAL  
MODIFICATIONS?*



Thomas LUYCKX, MD







Joint Degree KU Leuven/UGent  
Biomedical Sciences Group  
Faculty of Medicine  
Department of Development and  
Regeneration



# THE TIBIO-FEMORAL JOINT LINE

*WHAT IS THE BIOMECHANICAL AND CLINICAL EFFECT OF SURGICAL  
MODIFICATIONS?*

Thomas LUYCKX, MD

Promotors: Philippe Debeer, MD, PhD (KU Leuven)  
Jan Victor, MD, PhD (UGent)

Jury

Chair: Rik Lories, MD, PhD (KU Leuven)  
Secretary: Koen Peers, MD, PhD (KU Leuven)

Internal Jury members: Koen Peers, MD, PhD (KU Leuven)  
René Westhovens, MD, PhD (KU Leuven)  
Catherine Van Der Straeten, MD, PhD (UGent)  
Jacob Sukumaran, Ir, PhD (UGent)

External Jury members: Fabio Catani, MD, PhD (Mondena; IT)  
Ate Wymenga, MD, PhD (Nijmegen; NE)

Doctoral Thesis in Biomedical Sciences  
Leuven, 20<sup>th</sup> March 2015

*"The best way to have a good idea is to have a lot of ideas"*  
Linus Pauling

*"If we knew what it was we were doing, it would not be called research, would it?"*  
Albert Einstein

# TABLE OF CONTENTS

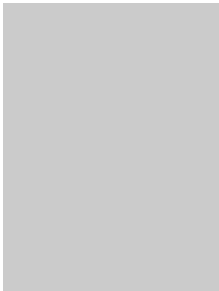
<b>Chapter 1: Introduction and Objectives</b>	7
<b>1.1 Preface</b>	9
<b>1.2 The Tibio-Femoral Joint line of the knee</b>	12
1.2.1 <i>Joint line in the native knee</i>	12
1.2.2 <i>Joint line in the replaced knee</i>	17
1.2.3 <i>Conclusion</i>	23
<b>1.3 Aims of the thesis</b>	24
<b>Chapter 2: The tibio-femoral joint line in the native knee</b>	29
<b>2.1 The tibio-femoral Joint line in the coronal plane</b>	31
2.1.1 <i>The position of the joint line in the normal knee</i>	31
2.1.2 <i>The orientation of the joint line in the osteo-arthritic knee</i>	43
<b>2.2 The tibio-femoral Joint line in the axial plane</b>	60
<b>Chapter 3: The biomechanical effect of joint line elevation in TKA</b>	71
<b>3.1 The effect of elevating the level of the patellofemoral joint line</b>	73
<b>3.2 The effect of joint line elevation on strain in the medial collateral ligament</b>	89
3.2.1 <i>Development of a new method for strain measurement in human tendon tissue.</i>	89
A. <i>Validation of digital image correlation as a tool for strain analysis in human tendon tissue.</i>	89
B. <i>Application of digital image correlation for 3D strain analysis of the superficial medial collateral ligament of the knee</i>	102
3.2.2 <i>The effect of joint line elevation on strain in the medial collateral ligament</i>	119
<b>3.3 The effect of joint line elevation on coronal plane stability of the knee</b>	131
<b>3.4 Development and validation of a geometrical model of the knee to predict the effect of joint line changes on the coronal plane stability</b>	146
3.4.1 <i>Rationale</i>	146
3.4.2 <i>Development of a geometrical model of the knee</i>	146
3.4.3 <i>Predicting the effect of joint line changes</i>	152
3.4.4 <i>Discussion</i>	158
3.4.5 <i>Conclusion</i>	160

<b>Chapter 4: The tibio-femoral joint line in the replaced knee</b>	163
<b>4.1 The orientation of the tibio-femoral joint line in the axial plane</b>	165
<b>4.2 The orientation of the tibiofemoral joint line in the coronal plane</b>	176
<i>4.2.1 The effect of joint line orientation on alignment after TKA</i>	176
<i>4.2.2 The effect of joint line orientation on clinical outcome after TKA</i>	187
<b>Chapter 5: Concluding discussion and future perspectives</b>	199
<b>Summary</b>	211
<b>Samenvatting</b>	213
<b>Curriculum Vitae</b>	215
<b>Dankwoord</b>	221

# **CHAPTER 1: INTRODUCTION AND OBJECTIVES**

---

**1**



# *CHAPTER 1: CONTENTS*

---

<b>1.1 Preface</b>	<b>9</b>
<b>1.2 The Tibio-Femoral Joint line of the knee</b>	<b>12</b>
1.2.1 Joint line in the native knee	12
1.2.2 Joint line in the replaced knee	17
1.2.3 Conclusion	23
<b>1.3 Aims of the thesis</b>	<b>24</b>

# CHAPTER 1: INTRODUCTION AND OBJECTIVES

---

## 1.1 PREFACE

Total knee arthroplasty (TKA) is generally considered a very successful procedure to treat patients with end-stage osteoarthritis (OA) of the knee. It continues to enhance the quality of life and alleviate pain for a large number of patients. This surgical procedure carries such a high success rate that it has become one of the most frequently performed orthopaedic procedures, with more than 600 000 procedures performed per year in the United States alone. These numbers are expected to further increase as we are faced with an aging population with increased life expectancy, increasing body mass index and increasing functional demands. Simulations show that the number of primary total knee arthroplasties performed per year is projected to grow by 673% to 3.48 million procedures in the United States in 2030 [5]. Total knee revisions are projected to grow by 601% between 2005 and 2030 [5]. The impact of these procedures on health care resources will therefore become huge.

Previous studies have shown a high survivorship for TKA, with more than 90% of the prosthetic knees being in place at 10 years and beyond [1, 6, 7]. The majority of published studies evaluate the outcome of TKA using survivorship of the implant as the primary end point. Although these results are encouraging, they only tell part of the story. Equally important for the patient, if not more important, is how well a TKA functions during its survival and whether it is considered successful by the patient himself.

Most surgeons who perform TKA are aware that some patients with seemingly well-fixed, well-positioned and well-aligned components continue to complain of pain. In fact, recent studies show us that as many as 15% to 20% of patients either feel dissatisfied or very dissatisfied about their TKA and only 60% report their knee to feel normal [2, 9, 13]. Persistent pain is the major reason for the dissatisfaction. In addition, it has been demonstrated that function post-TKA in young patients (40-50 years) is even worse with a patient satisfaction rate of only 75% [11, 16]. Thus a significant number of patients are dissatisfied with their TKA. Therefore, a good survival does not always equal a good function of the implant.

Unmet or unrealistic expectations could be a possible explanation for dissatisfaction in some patients [17, 18]. However, other studies show that higher preoperative expectations *per se* are associated

with better outcomes [19, 20]. Further studies suggest that the actual post-treatment status with regards to symptoms or function more strongly governs whether the patient is satisfied with the result, regardless of their prior expectations. In one study, knee pain at 2 years after surgery, was found to be the strongest predictor of patient satisfaction [21].

The functional results of the TKA contrast those of the total hip arthroplasty (THA) that show both excellent survival and function and as a result a high patient satisfaction rate. Also the unicompartmental knee arthroplasty (UKA) scores a lot better in terms of function and patient satisfaction than the TKA [10, 15]. There is in other words a 'function gap' between the UKA on the one side and the TKA on the other side. But why is this true and what can be done about it?

Companies and engineers have provided us with new TKA designs in an attempt to bridge the 'function gap'. If we look into the mechanisms for failure of a TKA between 1986 and 2000, many of them failed early due to implant-associated factors including wear, loosening and instability. More recent studies show us that today, with improvements in implant and polyethylene manufacture, polyethylene wear is no longer a leading cause of failure. Nowadays, 60% of the failures occur in the first five years and those early failures are primarily the consequence of technical errors [21]. In other words, the positioning of the implant by the surgeon has a major impact on its long-term survival.

Secondly, evidence shows us that patient satisfaction rates were remarkably consistent over a 15 year period which suggests that the functional results were sustained, and that innovation in TKA technology has had little effect on functional outcome [4, 8]. At the same time, recent evidence is showing us the importance of the surgeon himself as a variable for the functional result. How an implant is inserted can be considered of equal, if not of greater, importance than the implants itself [3, 12, 14]. However, despite the high number of TKAs that is performed yearly, there is still no consensus on what the 'optimal' position for a TKA might be. As long as this enigma has not been solved, new prosthetic designs serve no purpose.

This work therefore represents my quest for the 'optimal' position of the artificial tibio-femoral joint interface in an attempt to bridge part of the function gap. The tibio-femoral joint line will be used as tool to describe the position and orientation of that joint interface in the three-dimensional space.

By the end of this work, we hope to be able to provide some insights on the biomechanical and clinical effect of component position in TKA that might improve patient outcome.



## References

1. Argenson J-NA, Parratte S, Ashour A, Saintmard B, Aubaniac J-M (2012) The outcome of rotating-platform total knee arthroplasty with cement at a minimum of ten years of follow-up. *J. Bone Joint Surg. Am.* 94:638–44
2. Bourne RB, Chesworth BM, Davis AM, Mahomed NN, Charron KDJ (2010) Patient satisfaction after total knee arthroplasty: who is satisfied and who is not? *Clin. Orthop. Relat. Res.* 468:57–63
3. Dossett HG, Estrada N a, Swartz GJ, LeFevre GW, Kwasman BG (2014) A randomised controlled trial of kinematically and mechanically aligned total knee replacements: Two-year clinical results. *Bone Joint J.* 96-B:907–13
4. Dunbar MJ, Richardson G, Robertsson O (2013) I can't get no satisfaction after my total knee replacement: rhymes and reasons. *Bone Joint J.* 95-B:148–52
5. Kurtz S, Ong K, Lau E, Mowat F, Halpern M (2007) Projections of primary and revision hip and knee arthroplasty in the United States from 2005 to 2030. *J. Bone Joint Surg. Am.* 89:780–5
6. Lachiewicz PF, Soileau ES (2009) Fifteen-year survival and osteolysis associated with a modular posterior stabilized knee replacement. A concise follow-up of a previous report. *J. Bone Joint Surg. Am.* 91:1419–1423
7. Ma H-M, Lu Y-C, Ho F-Y, Huang C-H (2005) Long-term results of total condylar knee arthroplasty. *J. Arthroplasty Elsevier* 20:580–4
8. Nam D, Nunley RM, Barrack RL (2014) Patient dissatisfaction following total knee replacement: a growing concern? *Bone Joint J.* 96-B:96–100
9. Noble PC, Conditt M a, Cook KF, Mathis KB (2006) The John Insall Award: Patient expectations affect satisfaction with total knee arthroplasty. *Clin. Orthop. Relat. Res.* 452:35–43
10. Noticewala MS, Geller JA, Lee JH, Macaulay W (2012) Unicompartmental knee arthroplasty relieves pain and improves function more than total knee arthroplasty. *J. Arthroplasty* 27:99–105
11. Parvizi J, Nunley RM, Berend KR, Lombardi A V, Ruh EL, Clohisy JC, Hamilton WG, Della Valle CJ, Barrack RL (2014) High level of residual symptoms in young patients after total knee arthroplasty. *Clin. Orthop. Relat. Res.* 472:133–7
12. Ritter MA, Davis KE, Farris A, Keating EM, Faris PM (2014) The Surgeon's Role in Relative Success of PCL-Retaining and PCL-Substituting Total Knee Arthroplasty. *HSS J.* 10:107–15
13. Robertsson O, Dunbar M, Pehrsson T, Knutson K, Lidgren L (2000) Patient satisfaction after knee arthroplasty: a report on 27,372 knees operated on between 1981 and 1995 in Sweden. *Acta Orthop. Scand.* 71:262–267
14. Vanlommel L, Vanlommel J, Claes S, Bellemans J (2013) Slight undercorrection following total knee arthroplasty results in superior clinical outcomes in varus knees. *Knee Surg. Sports Traumatol. Arthrosc.* 21:2325–30
15. Wiik A V., Manning V, Strachan RK, Amis AA, Cobb JP (2013) Unicompartmental knee arthroplasty enables near normal gait at higher speeds, unlike total knee arthroplasty. *J. Arthroplasty* 28:176–178
16. HSCIC. Provisional Monthly Patient Reported Outcome Measures (PROMs) in England - April 2012 to March 2013.
17. Payer CK (2004) Expectations and outcomes in cataract surgery: a prospective test of 2 models of satisfaction. *Arch Ophthalmol* 122:1788-1792.
18. Ross CK, Frommelt G, Hazelwood L, Chang RW (1987) The role of expectations in patient satisfaction with medical care. *J Health Care Mark* 7:16-26.
19. Gonzalez Saenz de Tejada M, Escobar A, Bilbao A, Herrera-Espiñeira C, García-Perez L, Aizpuru F, et al. A prospective study of the association of patient expectations with changes in health-related quality of life outcomes, following total joint replacement. *BMC Musculoskelet Disord* 2014;15:248.
20. Mahomed NN, Liang MH, Cook EF, Daltroy LH, Fortin PR, Fossel AH, et al. The importance of patient expectations in predicting functional outcomes after total joint arthroplasty. *J Rheumatol* 2002;29(6):1273–1279.
21. Mannion AF, Kämpfen S, Munzinger U, Kramers-de Quervain I. The role of patient expectations in predicting outcome after total knee arthroplasty. *Arthritis Res Ther* 2009;11(5):R139.
21. Lombardi JV., Berend KR, Adams JB. Why knee replacements fail in 2013: patient, surgeon, or implant? *Bone Joint J* 2014;96-B(11):101–104.

## 1.2 THE TIBIO-FEMORAL JOINT LINE OF THE KNEE

### ***Adapted from:***

***T Luyckx, J Victor (2012) Alignment and biomechanics: a surgeon's perspective. In: Thienpont E (ed) Improving Accuracy in Knee Arthroplasty, 1st edn. Ajanta, New Delhi, pp 85-94***

Geometry, orientation and position of the tibiofemoral joint interface determine knee function. This is intimately related to knee kinematics, kinetics and stability. The tibiofemoral joint interface is shaped to work in synergy with the ligaments that surround the knee, some of which are isometric in nature, some not [51]. This complex interaction between ligaments and joint interface is still insufficiently understood and remains a major challenge for ligament and joint reconstruction. In the field of knee arthroplasty, the joint interface has often been called the 'joint line', which is a significant two-dimensional simplification of the complex three-dimensional (3D) characteristics, induced by a 'radiological' visualization of the joint. Still, this simplified two-dimensional description of the three-dimensional reality offers the advantage of practicality in use for surgical procedures. For this reason, we will use the term joint line in this text, well aware of the conceptual restrictions associated with this dimensional reduction.

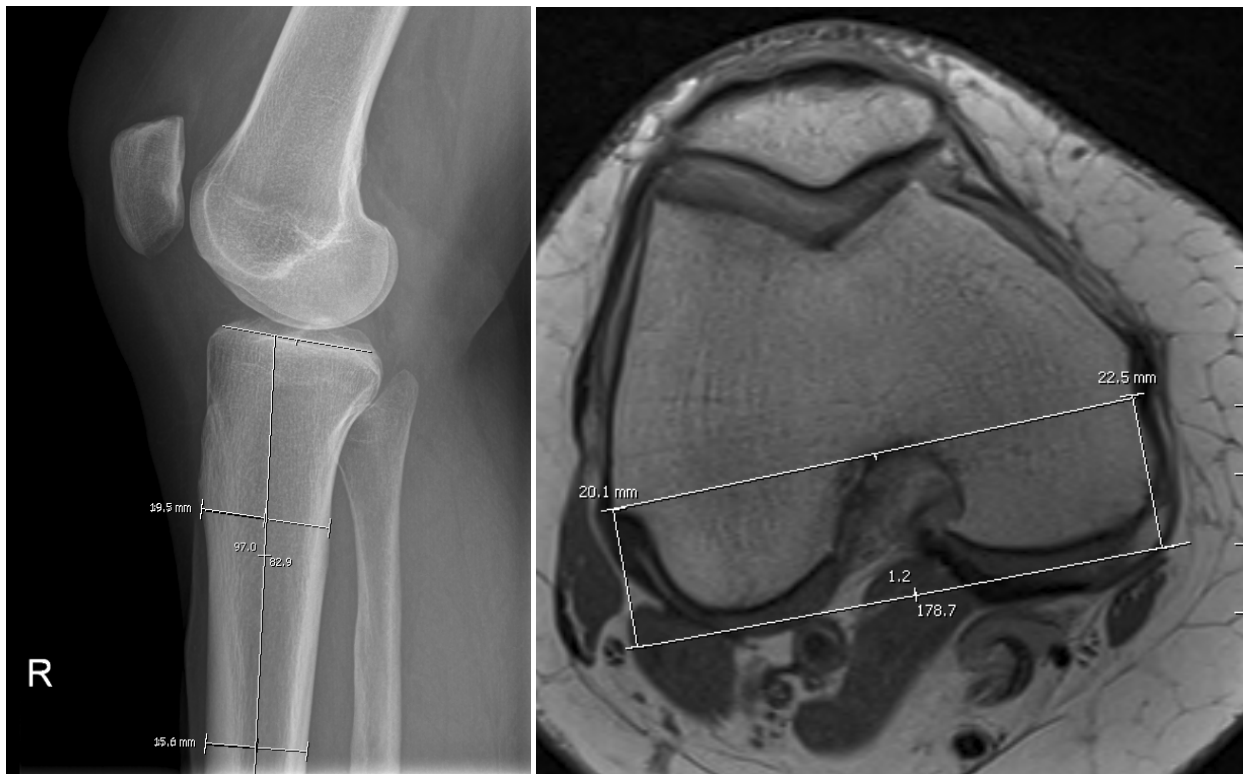
In the coronal plane, joint line position (cranial-caudal) and joint line orientation (varus-valgus) should be distinguished [28]. In the sagittal plane, joint line orientation is often referred to as slope, with increased flexion being denominated as increased slope (fig 1a). In the axial plane, the tibiofemoral joint line is often referred to as posterior condylar line (fig 1b). Its position is described in terms of rotation relative to a certain reference frame. The trochlear antero-posterior axis (Whiteside's line) and the transepicondylar axis are the most frequently used rotational references.

The goal of this introduction is to provide an overview of the published literature on the tibiofemoral joint line in the native knee, in primary knee arthroplasty and in revision knee arthroplasty.

### 1.2.1 JOINT LINE IN THE NATIVE KNEE

In the native knee, the joint interface can be defined as the tangent of the cartilage contact surface between the medial and lateral tibial plateaus with the femoral condyles. Despite this contact surface often being described as a fixed area or points, joint load will alter the shape and position through plastic deformation [37]. Second, the joint line is mostly described from a static point of view with the knee in extension. It is however a dynamic structure and joint motion will alter the position

of the joint line in the 3D space. Knowledge of both knee kinetics and kinematics is important to understand the changing position of the knee joint line throughout the range of motion.



**Figure 1:** Joint line orientation in the sagittal plane (a). There is a postero-inferior slope relative to the tibial shaft of on average 7 degrees. In the axial plane (b), the orientation of the joint line is referred to as rotation. In the example, an internal rotation of 1.2° relative to the posterior condylar line is seen.

#### a) JOINT LINE POSITION

In the native knee, the joint line in the **coronal plane** is described as the line that connects the middle of the medial and lateral joint space on an AP X-ray, and is as such a radiological feature. Some authors have called this line the *knee transverse axis* (fig 2). The cranio-caudal position of the joint line in the medial and lateral compartment can be described in relationship to different femoral and tibial landmarks, using different measuring methods. A distinction can be made between the ‘bony’ joint line and the joint line taking to account the cartilage.

Based on surgical experience, the normal joint line was reported to be approximately 25 mm caudal to the medial femoral epicondyle and 10 mm cranial to the fibular head [41].

Servien et al. found the mean distance from the epicondyles to the joint line to be respectively 23 mm on the lateral side and 28 mm on the medial side [47]. A variation of this distance from the

epicondyles to the joint line of up to 11 mm was described and a significant difference was found between males and females. By defining these distances as a ratio of the femoral width, values independent of size can be calculated [47]. The ratio of the distance from the epicondyles to the joint line, to the femoral width was 0.28 for the lateral side and 0.34 from the medial side. These values showed only small variations [47].



**Figure 2:** MRI image of the left knee. The tibio-femoral joint line or ‘knee transverse axis’ is shown in relationship to the medial and lateral epicondyle.

In relation to tibia and fibula, the joint line was found to be on average 14 mm cranial to the tip of the fibular head and on average 22 mm cranial to the tibial tubercle (fig 3) [47]. Still, there is a large variation in these absolute values mainly depending on the size of the individual.

#### *b) JOINT LINE ORIENTATION*

Kapanjii was the first to recognise that the orientation of the joint line in the **coronal plane** is not perpendicular to the mechanical axis but is in 3 degrees of varus. With this orientation, the joint line remains parallel to the ground during single leg stance in gait or during two-legged stance with feet together [30]. This was confirmed by Moreland et al, who showed that the transverse axis of the knee is, on average, oriented with 3° (right knee) and 2.6° (left knee) varus inclination (sloping down medially) with respect to the mechanical axis of the tibia [40] (fig 4). There is a gender difference in varus inclination of the knee transverse axis with a mean 3.5° in males and 2.5° in females [24]. In

addition, there is a correlation between the knee transverse axis and the overall leg alignment [42]: in neutrally aligned knees there is a varus inclination of the tibial plateau of on average  $3^\circ$ ; in varus knees the medial inclination is on average  $5^\circ$  and in valgus knees the medial inclination is on average only  $1^\circ$  [6]. When measured from the femoral side, the joint line is generally oriented in valgus (medial condyle more distally than the lateral in the coronal plane). This valgus orientation is on average  $1^\circ$  in varus knees,  $2^\circ$  in neutral knees and  $5^\circ$  in valgus knees [6]. This supports the idea that in varus knees, the proximal tibial deformity is the main contributing factor to the varus. In valgus knees on the other hand, the major deformity is situated on the femoral side.



**Figure 3:** Position of the joint line relative to the tip of the fibular head.

In the **sagittal plane**, the joint line is also not perpendicular to the mechanical axis of the tibia. There is a postero-inferior inclination of the tibial surface, referred to as posterior tibial slope (fig 1a). Tibial slope can be defined as the angle between the perpendicular to the middle part of the diaphysis of the tibia and the line representing the posterior inclination of the tibial plateau [21]. The postero-inferior slope of the tibia is said to be  $10^\circ \pm 3^\circ$  but values between  $2^\circ$  and  $15^\circ$  are reported in literature [13,14]. The reason for this high variability is a high individual variation, a high inter-observer variability for measuring tibial slope and the different measuring methods being used (lateral X-ray vs. MRI, different reference axes). Moreover, when the soft tissues (cartilage, menisci) are taken into account, slope is compensated to a near neutral state. Whereas on lateral radiographs

the medial and lateral plateau are superimposed, measuring slope on CT or MRI has the advantage of differentiating the medial and the lateral plateau with their distinct geometry. One study reported a mean medial tibial slope of  $5.9^\circ$  and a mean lateral tibial slope of  $7.0^\circ$  degrees in females and a mean medial tibial slope of  $3.7^\circ$  and mean lateral tibial slope of  $5.4^\circ$  in males [24]. Both differences between medial and lateral and between males and females were significant. There seems to be no relationship between the coronal alignment and posterior tibial slope [39].

The posterior slope is a geometrical factor contributing to antero-posterior (AP) stability. Increased posterior slope is associated with more linear AP translation [13]. An increased posterior tibial slope has also been associated with an increased incidence of anterior cruciate ligament rupture caused by an increase in anteriorly directed shear force [9,22]. All this led researchers to suggest that increasing the tibial slope could benefit posterior cruciate ligament-deficient knees, whereas decreasing it could benefit anterior cruciate ligament-deficient knees.



**Figure 4:** RX full leg standing showing a neutrally aligned leg with a  $3^\circ$  of varus inclination of the knee transverse axis.

A tangent of the posterior condyles (= posterior condylar line) defines the joint line in **the axial plane** (fig 1b). Its orientation is described in relationship to some reference axis. Several different reference axes have been introduced from which the surgical transepicondylar axis (sTEA), the anatomical

transepicondylar axis (aTEA) and the trochlear anteroposterior axis (TRAx) are the most popular ones. A recent review of literature has shown that in the native knee, the PCL is on average 3° internally rotated relative to sTEA and 5° internally rotated relative to the aTEA. However, there is a lot of inter-individual variation in these values.

All of the above are descriptions of the static joint line in full extension. However, with increasing flexion the tibiofemoral relationship will change in three dimensions. As such, the description of the joint line, relative to tibial landmarks remains useful, in contrast to the relative position to femoral landmarks, which will depend on kinematic changes

## 1.2.2 JOINT LINE IN THE REPLACED KNEE

### a) *JOINT LINE IN PRIMARY TKA*

When performing a total knee arthroplasty (TKA), there is little disagreement that a well-aligned prosthesis, centred on the mechanical axis, is an important outcome parameter. There are, however, different views as to the orientation of the prosthetic joint line in the **coronal plane**.

In the beginning of the eighties, Hungerford, Kenna and Krakow introduced the '**anatomical alignment**' method. The key in their philosophy was maintaining the joint line in its original position and orientation [28]. In the coronal plane, this means a 2° to 3° varus orientation of the tibial component. To obtain this, they propagated to exactly resect the amount of bone that is replaced by the prosthetic components (typically 9 mm). Doing so will automatically place the prosthetic joint line at the same level and orientation as in the native knee. This concept was named 'measured resection' and to date, the concept is still incorporated to some degree in most instrumentation systems.

The most common form of coronal TKA alignment was promoted by Freeman [20] and Insall [31]. This method has been referred to as the 'classic' or '**mechanical alignment**' and produces minor offsetting malalignment of the femoral and the tibial components. In this method, the tibial and femoral cuts are made perpendicular to the mechanical axis. As the transverse knee axis makes an angle 87° with the mechanical axis of the tibia, this method produces a relative 3° varus malalignment of the femoral component and a compensatory 3° valgus malalignment of the tibial component compared to the natural situation. The result is a slight over-resection of the lateral

proximal tibia and a slight under-resection of the lateral distal femur. The relative lateral tibial over-resection of results in a trapezoidal flexion space with lateral joint opening [45]. Most systems using mechanical alignment therefore recommend external rotation of the femoral component to compensate on the femoral side for the lateral over-resection of the tibia. By doing so, a rectangular and balanced flexion space is again obtained [53].

The main advantage of this alignment method was that as the tibial cut is perpendicular, the same tibial instrumentation and prosthesis could be used for right and left knees. Later on, it was shown that the neutral mechanical alignment provided a better load distribution across the components and a better long-term survival of the implant [44]. It has therefore been the gold standard for alignment in TKA for almost 30 years.

The anatomic alignment has seen a recent revival due to the introduction of the ***kinematic alignment***. The purpose of the kinematic alignment is to align the femoral and tibial component to the kinematic axis of the knee. To achieve this, a pure measured resection approach is used. The aim hereby is to resect exactly the amount of bone and cartilage that matches implant thickness. By doing this, the joint surface is restored at its original level. On the femoral side this means slight valgus of the component in the coronal plane and no external rotation in the axial plane. On the tibial side, the cut is made parallel to the surface, after compensating the wear. Thus, many tibial components will be placed in slight varus.

The result is a TKA that is placed to match the patient's original anatomy. The concept is appealing and some studies have shown a better functional outcome compared to mechanical alignment. However, major concern for many authors with this alignment method is the possible medial overload of a tibial component in varus. A decrease in the long-term survival could be the result.

Originally, Hungerford and Kenna propagated the use of a neutral tibial cut in **the sagittal plane**, meaning 0° of posterior slope. Nowadays, many surgeons believe that increasing tibial slope in TKA will lead to better flexion, especially in a posterior cruciate retaining (CR) design [7]. However, the literature does not clearly confirm this hypothesis. One of the dangers of using a cutting block with posterior slope is that excessive externally or internally rotating the cutting block relative to the tibia, will induce a postero-medially or –laterally sloped tibial cut. This can result in mid-flexion instability. Moreover, concern is raised with respect to the tibial insertion site of the posterior cruciate ligament (PCL) as increasing slope might damage the insertion site and thus cause instability. It is important to note that altering the slope also influences the antero-posterior stability of the knee. When axial loading is combined with the posterior slope, an anteriorly directed shear force component will be induced causing a corresponding anteriorly directed translation of the tibia. As in most TKA designs



the anterior cruciate ligament (ACL) is sacrificed, this may lead to anterior instability and laxity in mid-flexion. Therefore, it is generally accepted that posterior tibial slope in TKA should not exceed 7°.

The orientation of the prosthetic joint line in **the axial plane** is referred to as rotational alignment of the femoral component. It depends on the alignment method used in the coronal plane. With mechanical alignment, the target is to align the prosthetic joint line in the axial plane (= posterior condylar line) parallel to the surgical transepicondylar axis. This axis is oriented on average in 3° internal rotation relative to the posterior condyles. Many surgeons will therefore choose to externally rotate the femoral component by 3° using Whiteside's line, the posterior condyles and the epicondyles as surface landmarks.

This contrasts the approach in kinematic alignment where the posterior condylar line of the TKA will be placed parallel to the original joint surface in the axial plane. On average, this means 3° of internal rotation of the femoral component relative to the surgical transepicondylar axis.

#### *b) JOINT LINE IN REVISION TKA*

More than in primary TKA, joint line reconstruction is a well-known problem in revision TKA. A strong tendency exists for surgeons to raise the joint line in revision TKA. There are several reasons for this [4]. The surgeon is almost invariably faced with distal femoral bone loss and posterior femoral bone loss. When this bone loss is not compensated by augmentation on the femoral side, a thicker polyethylene insert will be required to obtain adequate ligament balance and an elevated joint line will be the result. Moreover, the surgeon is frequently faced with a relatively larger flexion space. This is a consequence of the fact that in the revision situation, the capsule-ligamentous structures that are effective in extension are usually better preserved than those that control the knee in flexion. All this will cause the surgeon to proximalise the joint line. It has been suggested that a number of landmarks can be used intra-operatively to assess whether the joint line has been restored. These include the old meniscal scar if visible, or at a point 1.5 cm cranial to the fibular head, 2.2 cm cranial to the tibial tuberosity, 2 cm to 2.5 cm caudal to the lateral femoral epicondyle or 2.5 cm to 3 cm caudal to the medial femoral epicondyle [4,47]. A more precise method is the one of Servien [47]. She found that the ratio of the distance from the epicondyles to the joint line, to the femoral width was 0.28 for the lateral side and 0.34 from the medial side. By measuring the femoral width, the joint line position relative to the epicondyles can be accurately calculated. A major advantage of this method is that it almost completely eliminates the inter-individual, size dependent variation observed for joint line position.

Partington reported an elevation of the joint line as measured on AP radiographs in 79% of the revision cases [41]. The elevation averaged 8 mm. Contemporary prosthetic designs try to overcome this problem with distal and posterior femoral augments. They succeeded in reducing the elevation and improving patient outcome. However, the availability of extensive modular revision systems did not solve all problems. Authors still observe a joint line elevation in up to 50% of their revision cases despite the use of distal femoral augments. Difficulties with accurately localising the surface landmarks intra-operative explain part of the problem.

*c) JOINT LINE CHANGE AND ITS CONSEQUENCES*

Whereas joint line changes are to be expected after revision TKA, one would expect the joint line to be perfectly reconstructed at its original level in primary TKA by using a measured resection technique. However, several papers show a consistent trend to joint line elevation in the coronal plane after primary TKA. In addition, some authors theorized that the removal of the PCL would increase this elevation because of the loss of posterior support between the femur and tibia and the subsequent larger flexion space. Kawamura and Bourne reported on the joint line position change after primary TKA. They found a mean elevation of 3.5 and 2.4 as measured on AP and lateral radiographs respectively [35]. Cope et al, using the tibial tuberosity as a reference, showed a joint line position change after primary TKA of 2 mm for a posterior stabilised (PS) prosthesis and 3 mm for a cruciate retaining (CR) device. The differences between the CR and PS designs were not significant [12]. Snider reported a mean joint line elevation of 3.8 and 4.3 as measured on AP and lateral radiographs respectively using tibial references [49]. Comparing two implants with their CR and PS designs, they found a significantly greater joint line elevation for the PS design vs. the CR design in one implant (5.6 vs 3.8 mm) but not in the other. In a study using navigation as a direct measurement method for joint line position after TKA, Ensini et al found a significant joint line elevation of 1.9 mm when measured from the tibial side and 0.3 mm from the femoral side [16]. The question whether joint line elevations in this range are clinically relevant, remains unanswered.

In conclusion, it seems that changes in joint line level seem inevitably connected with knee replacement surgery. Surgical alignment technique, using worn anatomical structures as references and cruciate resection are all factors that can contribute to this joint line change.

- **Effect on knee stability and ligament balance**

Freeman and Insall were the first to recommend balancing the knee ligaments by restoring the flexion and extension gap [19,32]. Since then, studies have shown that joint line position plays an important role in knee kinematics and function. In 1985, as a reaction on the mechanical alignment promoted by Insall and Freeman, Hungerford stated: *“ligament balance is principally a function of the femoral component and joint line positions relative to the femoral origins of the collateral and cruciate ligaments”* [29]. Position and size of the implant are the major determinant of postoperative knee kinematics and joint function. The restoration of the original joint line is a prerequisite for this. Historically, the anatomical alignment technique has been used with posterior cruciate ligament (PCL) retention and a neutral tibial cut in the sagittal plane [29]. The preservation of the PCL is believed to offer many potential advantages: it has an important varus-valgus stabilization function, controls to a certain extent rollback and has a proprioceptive function. However, to function properly, the PCL must be accurately tensioned. If the PCL is too tight, excessive femoral rollback may occur with decreasing flexion and increasing posterior polyethylene stress. When the PCL is too loose, tibiofemoral instability leads to tibial sagging, posterior tibiofemoral impingement and limited flexion [3,5]. Maintaining adequate PCL tension is dependent on maintaining the original level of the joint line. When the joint line is positioned more cranial or in up-slope, the PCL will tighten in 90° of flexion, often requiring a partial PCL release [38].

The effect of joint line changes on the collateral ligaments remains somewhat unclear. It's now generally accepted that the superficial medial collateral ligament (sMCL) is an near isometric ligament [51]. Changes in joint line position and thus tibiofemoral centre of rotation may alter this isometric behaviour. As the sMCL is the primary stabiliser against valgus stress, this will affect joint stability. While determining the isometric point of the sMCL on the femur and tibia, Feeley et al found an important increase in strain of the sMCL for the non-anatomical insertions [55]. A change in femoral component position relative to the insertion site of the collaterals will have a similar effect causing excessive laxity or tensioning in flexion. There are other data to support this point of view. Bryan and Rand reported the importance of maintaining the correct centre of rotation during revision knee arthroplasty to prevent laxity in flexion [10]. Whiteside and Summers reported that under-resection of the distal femoral surface produces instability in flexion despite proper balancing in extension. Distal over-resection produces excessive ligament tightness in flexion [52]. Sidles et al., found with a computer-generated model that failure to restore normal joint line position may result in mid-flexion laxity or tightness (a). In a cadaver experiment, Martin et al investigated varus-valgus, anterior-posterior and rotational stability after TKA [38]. They found no significant change in stability when the joint line was maintained in its natural position. However, when the femoral component

was repositioned 5 mm proximally and 5 mm anteriorly, a significant increase in laxity occurred during mid-flexion. When the joint line was shifted 5 mm distal and 5 mm posterior to its anatomic location, significant tightening occurred in midrange of motion.

It is clear from these data that the position of the joint line has an important effect on collateral ligament isometry and joint stability. The exact effect depends on the direction and the amount of the joint line change but remains insufficiently understood.

- **Effect on patellofemoral joint**

The creation of a relative patella baja is another consequence of joint line elevation, especially in revision TKA. This lower patella position relative to the joint line, was termed pseudo-baja, as the patellar tendon remains equal in length but the distance to the tibial plateau is shortened [23]. For this reason, patellar height as measured with the Insall-Salvati ratio remains unchanged. Indices taking into account the joint line like the Caton-Deschamps and the Blackburne-Peel index will reveal the joint line elevation. Elevated patellofemoral joint contact forces and contact pressures are reported consequences of the relative lower patellar position [37]. Mechanical impingement of the low riding patella against the tibial insert can cause pain and limited knee flexion [41, 54]. Moreover, in posterior stabilized TKA designs, impingement of the tibial post against the patellar component was observed in deep flexion [50]. This type of impingement was clearly associated with a raised joint line and patella baja.

- **Effect on patient outcome**

In his original paper in 1986, Figgie already identified three major parameters affecting the clinical result after TKA. The position of the joint line was one of them. He stated that a change in joint line of less than 8 mm should be the aim [18]. Greater changes were associated with an inferior clinical result. Similar results were reported by Shoji [48]. Partington found a reduced mean Knee Society clinical rating score from 141 points to 125 points if the joint line elevation after revision TKA exceeded 8 mm. The difference did not reach statistical significance. However, they observed a trend toward worse clinical outcome with either excessive elevation or depression of the joint line. Porteous et al reported on 114 revision TKA's [43]. The height of the joint line before and after revision total knee replacement was measured and classified as either restored to within 5 mm of the pre-operative height or elevated if it was positioned more than 5 mm above the pre-operative height. The joint line was elevated in 41 knees (36%) and restored in 73 (64%). At one year post-operatively both the total Bristol knee score and its functional component were significantly better in the restored group than in the elevated group ( $p < 0.01$ ). This improvement in scores with joint line

restoration occurred at one year post-operatively and was still present in those patients followed for five years. Hoffman found more improvement with recreation of the normal joint line to within 4 mm of the normal unaffected knee for Knee Society Score, average total arc of motion, flexion, and extension after revision TKA [25].

Others were not able to find a correlation between joint line elevation and clinical outcome [4,46,49].

Joint line elevation after TKA is also risk factor for the development of postoperative stiffness in PCL-retaining designs due to PCL tightness as discussed previously.

No doubt that the overall leg alignment after total knee replacement is one of the most important factors determining the long-term survival of the prosthesis. The alignment of the individual components (and thus the orientation of the joint line), which contributes to this alignment, is more recently identified as being an important factor. Varus orientation of the tibial component of more than 3° is reported to lead to medial bone collapse and higher failure rates [8]. Moreover, compensating a varus aligned tibial component by a valgus aligned femoral component (and thus changing joint line orientation) to obtain an overall neutral alignment may actually increase the risk of failure [44].

### 1.2.3. CONCLUSION

The tibiofemoral joint interface is a three-dimensional concept with important consequences for kinematics, knee function and patient outcome. Changes, induced by an artificial replacement of the joint, can lead to stiffness, instability and limited range of motion. There is increasing evidence in the literature that accurate restoration of form, orientation and position of the tibiofemoral interface is a prerequisite for improved function in our patients.

## 1.3 AIMS OF THE THESIS

The aims of this thesis were to:

1. Describe the POSITION and ORIENTATION of the tibio-femoral joint line in the coronal and axial plane in the native knee.
2. Investigate the biomechanical effect of a proximal POSITION of the tibio-femoral joint line (= joint line elevation) in TKA on:
  - a) The patellofemoral joint
  - b) The strain in the superficial collateral ligament
  - c) The tibio-femoral stability in the coronal plane
3. Investigate the effect of joint line ORIENTATION in the replaced knee on limb alignment and clinical outcome.

## REFERENCES

1. B Weber WE, W. E.: In *Mechanik der menschlichen Gehwerkzeuge*. Edited, Göttingen, Germany, Verlag der Dietrichschen Buchhandlung, 1836.
2. Bach, J. M., and Hull, M. L.: A new load application system for in vitro study of ligamentous injuries to the human knee joint. *J Biomech Eng*, 117(4): 373-82, 1995.
3. Banks, S. A.; Harman, M. K.; Bellemans, J.; and Hodge, W. A.: Making sense of knee arthroplasty kinematics: news you can use. *J Bone Joint Surg Am*, 85-A Suppl 4: 64-72, 2003.
4. Bellemans, J.: Restoring the joint line in revision TKA: does it matter? *Knee*, 11(1): 3-5, 2004.
5. Bellemans, J.; Banks, S.; Victor, J.; Vandenneucker, H.; and Moemans, A.: Fluoroscopic analysis of the kinematics of deep flexion in total knee arthroplasty. Influence of posterior condylar offset. *J Bone Joint Surg Br*, 84(1): 50-3, 2002.
6. Bellemans, J.; Colyn, W.; Vandenneucker, H.; and Victor, J.: The Chitranjan Ranawat Award: Is Neutral Mechanical Alignment Normal for All Patients?: The Concept of Constitutional Varus. *Clin Orthop Relat Res*, 2011.
7. Bellemans, J.; Robijns, F.; Duerinckx, J.; Banks, S.; and Vandenneucker, H.: The influence of tibial slope on maximal flexion after total knee arthroplasty. *Knee Surg Sports Traumatol Arthrosc*, 13(3): 193-6, 2005.
8. Berend, M. E.; Ritter, M. A.; Meding, J. B.; Faris, P. M.; Keating, E. M.; Redelman, R.; Faris, G. W.; and Davis, K. E.: Tibial component failure mechanisms in total knee arthroplasty. *Clin Orthop Relat Res*, (428): 26-34, 2004.
9. Brandon, M. L.; Haynes, P. T.; Bonamo, J. R.; Flynn, M. I.; Barrett, G. R.; and Sherman, M. F.: The association between posterior-inferior tibial slope and anterior cruciate ligament insufficiency. *Arthroscopy*, 22(8): 894-9, 2006.
10. Bryan, R. S., and Rand, J. A.: Revision total knee arthroplasty. *Clin Orthop Relat Res*, (170): 116-22, 1982.
11. Churchill, D. L.; Incavo, S. J.; Johnson, C. C.; and Beynon, B. D.: The transepicondylar axis approximates the optimal flexion axis of the knee. *Clin Orthop Relat Res*, (356): 111-8, 1998.
12. Cope, M. R.; O'Brien, B. S.; and Nanu, A. M.: The influence of the posterior cruciate ligament in the maintenance of joint line in primary total knee arthroplasty: a radiologic study. *J Arthroplasty*, 17(2): 206-8, 2002.
13. Dejour, H., and Bonnin, M.: Tibial translation after anterior cruciate ligament rupture. Two radiological tests compared. *J Bone Joint Surg Br*, 76(5): 745-9, 1994.
14. Dejour, H.; Neyret, P.; Boileau, P.; and Donell, S. T.: Anterior cruciate reconstruction combined with valgus tibial osteotomy. *Clin Orthop Relat Res*, (299): 220-8, 1994.
15. Eckhoff, D.; Hogan, C.; DiMatteo, L.; Robinson, M.; and Bach, J.: Difference between the epicondylar and cylindrical axis of the knee. *Clin Orthop Relat Res*, 461: 238-44, 2007.
16. Ensini, A.; Catani, F.; Biasca, N.; Belvedere, C.; Giannini, S.; and Leardini, A.: Joint line is well restored when navigation surgery is performed for total knee arthroplasty. *Knee Surg Sports Traumatol Arthrosc*, 2011.
17. Fick, R.: Mechanik des Kniegelenkes In *Handbuch der Anatomie des Menschen*, pp. 521. Edited by vonBardeleben, K., 521, Jena, Germany, Gustav Fischer, 1911.
18. Figgie, H. E., 3rd; Goldberg, V. M.; Heiple, K. G.; Moller, H. S., 3rd; and Gordon, N. H.: The influence of tibial-patellofemoral location on function of the knee in patients with the posterior stabilized condylar knee prosthesis. *J Bone Joint Surg Am*, 68(7): 1035-40, 1986.
19. Freeman, M. A.; Insall, J. N.; Besser, W.; Walker, P. S.; and Hallel, T.: Excision of the cruciate ligaments in total knee replacement. *Clin Orthop Relat Res*, (126): 209-12, 1977.
20. Freeman, M. A.; Swanson, S. A.; and Todd, R. C.: Total replacement of the knee using the Freeman-Swanson knee prosthesis. *Clin Orthop Relat Res*, (94): 153-70, 1973.

21. Genin, P.; Weill, G.; and Julliard, R.: [The tibial slope. Proposal for a measurement method]. *J Radiol*, 74(1): 27-33, 1993.
22. Giffin, J. R.; Vogrin, T. M.; Zantop, T.; Woo, S. L.; and Harner, C. D.: Effects of increasing tibial slope on the biomechanics of the knee. *Am J Sports Med*, 32(2): 376-82, 2004.
23. Grelsamer, R. P.: Patella baja after total knee arthroplasty: is it really patella baja? *J Arthroplasty*, 17(1): 66-9, 2002.
24. Hashemi, J.; Chandrashekar, N.; Gill, B.; Beynon, B. D.; Slauterbeck, J. R.; Schutt, R. C., Jr.; Mansouri, H.; and Dabezies, E.: The geometry of the tibial plateau and its influence on the biomechanics of the tibiofemoral joint. *J Bone Joint Surg Am*, 90(12): 2724-34, 2008.
25. Hofmann, A. A.; Kurtin, S. M.; Lyons, S.; Tanner, A. M.; and Bolognesi, M. P.: Clinical and radiographic analysis of accurate restoration of the joint line in revision total knee arthroplasty. *J Arthroplasty*, 21(8): 1154-62, 2006.
26. Hollister, A. M.; Jatana, S.; Singh, A. K.; Sullivan, W. W.; and Lupichuk, A. G.: The axes of rotation of the knee. *Clin Orthop Relat Res*, (290): 259-68, 1993.
27. Howell, S. M.; Howell, S. J.; and Hull, M. L.: Assessment of the radii of the medial and lateral femoral condyles in varus and valgus knees with osteoarthritis. *J Bone Joint Surg Am*, 92(1): 98-104, 2010.
28. Hungerford, D. S.; Kenna, R. V.; and Krackow, K. A.: The porous-coated anatomic total knee. *Orthop Clin North Am*, 13(1): 103-22, 1982.
29. Hungerford, D. S., and Krackow, K. A.: Total joint arthroplasty of the knee. *Clin Orthop Relat Res*, (192): 23-33, 1985.
30. IA, K.: *The Physiology of the Joints*. Ed 2. 1970.
31. Insall, J.; Ranawat, C. S.; Scott, W. N.; and Walker, P.: Total condylar knee replacement: preliminary report. 1976. *Clin Orthop Relat Res*, (388): 3-6, 2001.
32. Insall, J.; Tria, A. J.; and Scott, W. N.: The total condylar knee prosthesis: the first 5 years. *Clin Orthop Relat Res*, (145): 68-77, 1979.
33. Iwaki, H.; Pinskerova, V.; and Freeman, M. A.: Tibiofemoral movement 1: the shapes and relative movements of the femur and tibia in the unloaded cadaver knee. *J Bone Joint Surg Br*, 82(8): 1189-95, 2000.
34. Jeffcote, B.; Nicholls, R.; Schirm, A.; and Kuster, M. S.: The variation in medial and lateral collateral ligament strain and tibiofemoral forces following changes in the flexion and extension gaps in total knee replacement. A laboratory experiment using cadaver knees. *J Bone Joint Surg Br*, 89(11): 1528-33, 2007.
35. Kawamura, H., and Bourne, R. B.: Factors affecting range of flexion after total knee arthroplasty. *J Orthop Sci*, 6(3): 248-52, 2001.
36. Konig, C.; Matziolis, G.; Sharenkov, A.; Taylor, W. R.; Perka, C.; Duda, G. N.; and Heller, M. O.: Collateral ligament length change patterns after joint line elevation may not explain midflexion instability following TKA. *Med Eng Phys*, 2011.
37. Luyckx, T.; Didden, K.; Vandenuecker, H.; Labey, L.; Innocenti, B.; and Bellemans, J.: Is there a biomechanical explanation for anterior knee pain in patients with patella alta?: influence of patellar height on patellofemoral contact force, contact area and contact pressure. *J Bone Joint Surg Br*, 91(3): 344-50, 2009.
38. Martin, J. W., and Whiteside, L. A.: The influence of joint line position on knee stability after condylar knee arthroplasty. *Clin Orthop Relat Res*, (259): 146-56, 1990.
39. Matsuda, S.; Miura, H.; Nagamine, R.; Urabe, K.; Ikenoue, T.; Okazaki, K.; and Iwamoto, Y.: Posterior tibial slope in the normal and varus knee. *Am J Knee Surg*, 12(3): 165-8, 1999.
40. Moreland, J. R.; Bassett, L. W.; and Hanker, G. J.: Radiographic analysis of the axial alignment of the lower extremity. *J Bone Joint Surg Am*, 69(5): 745-9, 1987.
41. Partington, P. F.; Sawhney, J.; Rorabeck, C. H.; Barrack, R. L.; and Moore, J.: Joint line restoration after revision total knee arthroplasty. *Clin Orthop Relat Res*, (367): 165-71, 1999.



42. Poilvache, P. L.; Insall, J. N.; Scuderi, G. R.; and Font-Rodriguez, D. E.: Rotational landmarks and sizing of the distal femur in total knee arthroplasty. *Clin Orthop Relat Res*, (331): 35-46, 1996.
43. Porteous, A. J.; Hassaballa, M. A.; and Newman, J. H.: Does the joint line matter in revision total knee replacement? *J Bone Joint Surg Br*, 90(7): 879-84, 2008.
44. Ritter, M. A.; Davis, K. E.; Meding, J. B.; Pierson, J. L.; Berend, M. E.; and Malinzak, R. A.: The Effect of Alignment and BMI on Failure of Total Knee Replacement. *J Bone Joint Surg Am*, 93(17): 1588-96, 2011.
45. Romero, J.; Duronio, J. F.; Sohrabi, A.; Alexander, N.; MacWilliams, B. A.; Jones, L. C.; and Hungerford, D. S.: Varus and valgus flexion laxity of total knee alignment methods in loaded cadaveric knees. *Clin Orthop Relat Res*, (394): 243-53, 2002.
46. Selvarajah, E., and Hooper, G.: Restoration of the joint line in total knee arthroplasty. *J Arthroplasty*, 24(7): 1099-102, 2009.
47. Servien, E.; Viskontas, D.; Giuffre, B. M.; Coolican, M. R.; and Parker, D. A.: Reliability of bony landmarks for restoration of the joint line in revision knee arthroplasty. *Knee Surg Sports Traumatol Arthrosc*, 16(3): 263-9, 2008.
48. Shoji, H.; Solomonow, M.; Yoshino, S.; D'Ambrosia, R.; and Dabezies, E.: Factors affecting postoperative flexion in total knee arthroplasty. *Orthopedics*, 13(6): 643-9, 1990.
49. Snider, M. G., and Macdonald, S. J.: The influence of the posterior cruciate ligament and component design on joint line position after primary total knee arthroplasty. *J Arthroplasty*, 24(7): 1093-8, 2009.
50. Verborgt, O., and Victor, J.: Post impingement in posterior stabilised total knee arthroplasty. *Acta Orthop Belg*, 70(1): 46-50, 2004.
51. Victor, J.; Wong, P.; Witvrouw, E.; Sloten, J. V.; and Bellemans, J.: How isometric are the medial patellofemoral, superficial medial collateral, and lateral collateral ligaments of the knee? *Am J Sports Med*, 37(10): 2028-36, 2009.
52. Whiteside, L., and Summers, R.: The effect of the level of distal femoral resection on ligament balance in total knee replacement. *Annual Meeting of the Knee Society*, Atlanta(Feb. 9), 1984.
53. Worland, R. L.; Jessup, D. E.; Vazquez-Vela Johnson, G.; Alemparte, J. A.; Tanaka, S.; Rex, F. S.; and Keenan, J.: The effect of femoral component rotation and asymmetry in total knee replacements. *Orthopedics*, 25(10): 1045-8, 2002.
54. Yoshii, I.; Whiteside, L. A.; White, S. E.; and Milliano, M. T.: Influence of prosthetic joint line position on knee kinematics and patellar position. *J Arthroplasty*, 6(2): 169-77, 1991.
55. Feeley BT, Muller MS, Allen A a, Granchi CC, Pearle AD. Isometry of medial collateral ligament reconstruction. *Knee Surg Sports Traumatol Arthrosc* 2009;17(9):1078–82.



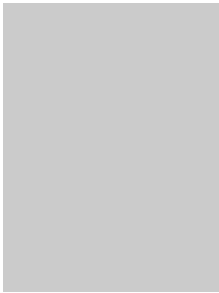
# **CHAPTER 2:**

# **THE JOINT LINE IN**

# **THE NATIVE KNEE**

---

**2**



## *CHAPTER 2: CONTENTS*

---

<b>2.1</b>	<b>The tibio-femoral Joint line in the coronal plane.</b>	<b>31</b>
2.1.1	The position of the joint line in the normal knee	31
2.1.2	The orientation of the joint line in the osteo-arthritic knee	43
<b>2.2</b>	<b>The tibio-femoral Joint line in the axial plane.</b>	<b>60</b>

# CHAPTER 2: THE TIBIO-FEMORAL JOINT LINE IN THE NATIVE KNEE

---

## 2.1 THE TIBIO-FEMORAL JOINT LINE IN THE CORONAL PLANE.

### 2.1.1 THE POSITION OF THE JOINT LINE IN THE NORMAL KNEE

**T Luyckx, L Beckers, W Colyn, H Vandenneucker, J Bellemans.**

The adductor ratio: a new tool for joint line reconstruction in revision TKA.  
*Knee Surg Sports Traumatol Arthrosc* 2014;22(12):3028–33.

#### ABSTRACT

##### **Purpose**

In this study, the value of the adductor tubercle as landmark for joint line reconstruction in revision Total Knee Arthroplasty was investigated.

##### **Methods**

On one hundred calibrated full-leg standing radiographs obtained from healthy volunteers, distances from the medial epicondyle, the lateral epicondyle, the adductor tubercle, the fibular head and the centre of the knee to the joint line were determined.

##### **Results**

The average distance to the joint line from the medial epicondyle, the lateral epicondyle, the adductor tubercle and the fibular head was found to be 27.7 mm (SD 3.0), 27.1 mm (SD 2.7), 44.6 mm (SD 4.3) and 15.1 mm (SD 3.7) respectively. The distance from the adductor tubercle ( $R=0.82$ ) and the centre of the knee ( $R=0.86$ ) to the joint line showed a strong and linear correlation with the

femoral width. The medial epicondyle, the lateral epicondyle and the fibular head showed less strong correlations. There was no significant correlation with the limb alignment.

The adductor ratio was defined as the distance from adductor tubercle to the joint line divided by the femoral width and was found to be 0.52 (SD 0.027) with only small inter-individual variation. The adductor ratio was the most accurate ratio and reconstructed the joint line within 4 mm of its original level in 92% of the cases.

### **Conclusion**

The adductor ratio is a reliable and accurate tool for joint line reconstruction in revision TKA. It was found to be more accurate than the use of absolute distances and the epicondylar ratios. This study supports the use of the adductor tubercle for joint line reconstruction in revision TKA.

### **Level of Evidence:**

Level II

## INTRODUCTION

One of the main goals of primary and revision Total Knee Arthroplasty (TKA) should be the restoration of the joint line at its original level [1]. It's a prerequisite for optimal knee function and prevention of complications like joint instability, anterior knee pain and a reduced range of motion of the knee [1, 3, 7, 16, 17]. In primary TKA, this can be quite easily established as all bony and ligamentous references are preserved. In revision surgery however, a part of these landmarks can no longer be identified, making reconstruction of the joint line to its original level much more challenging. Several studies using different imaging modalities like radiographs [9, 10, 12, 18, 22] and magnetic resonance imaging (MRI) [8, 19] have already been conducted to define a useful relationship between the joint line and these bony landmarks. The medial and lateral epicondyle, the adductor tubercle, the tibial tubercle and the tip of the fibular head are most frequently used.

In these previous series, the distances from these landmarks to the joint line were expressed as absolute values. Absolute values however are less useful because of the large variation that exists between the gender and the different sizes in knees [10, 15, 19]. A ratio of these distances to the femoral width has the theoretical advantage of overcoming the inter-individual size dependent variation. However, they require calibrated pre-operative radiographs and additional measurements and calculations during the surgery [10, 11, 18, 19]. Moreover, the intra-operative accuracy of locating the landmarks that are used for the ratios has proven to be very low [13, 21].

Recently, the adductor tubercle has been described as a useful landmark for determining joint line position showing a linear correlation with the femoral width [10]. Also its intra-operative localisation was shown to be more reproducible [11].

So far, none of the publications dealing with this topic used on calibrated radiographs or healthy individuals. Moreover, none of them has taken the alignment of the lower limb in account. This alignment could also have an important effect on the different distances and subsequent the ratios.

Therefore the purpose of this study was threefold. First of all, we wanted to validate the previously described distances and ratios on calibrated full-leg standing radiographs of young healthy volunteers and to compare these ratios to the newly defined adductor ratio. It was hypothesized that the adductor ratio would be equally accurate and reliable in defining the joint line level.

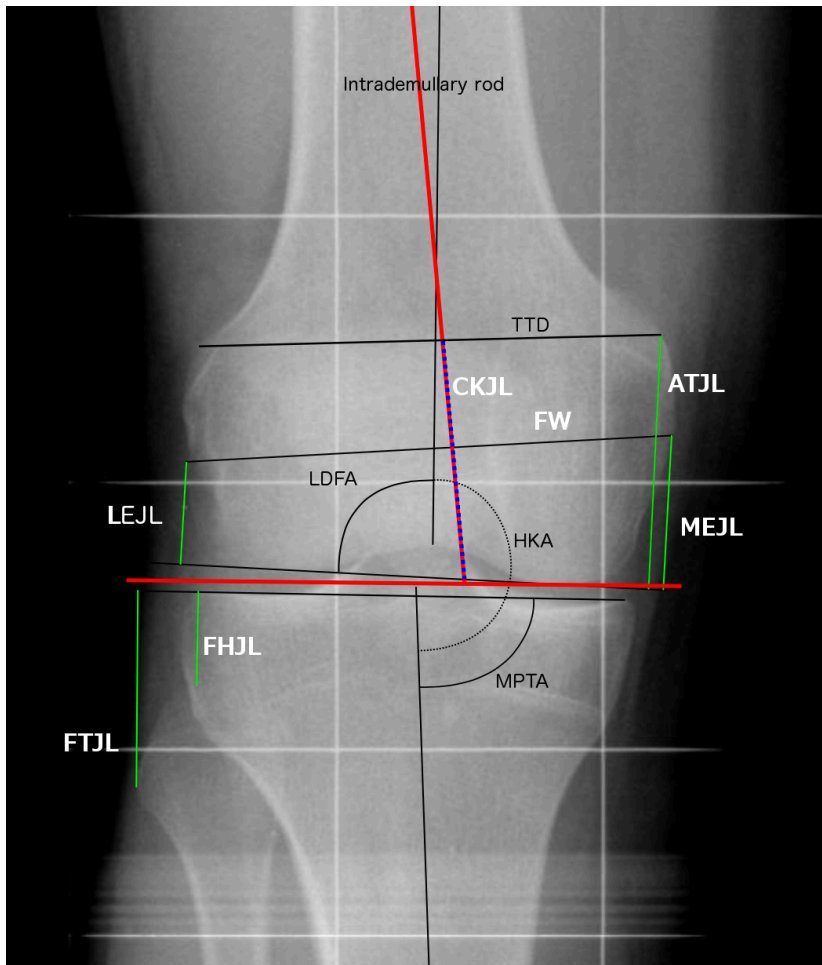
Secondly, the effect of gender and alignment on these distances and ratios was investigated.

Thirdly, the accuracy and reliability of these ratios as a tool for joint line reconstruction in revision TKA was explored.

## MATERIALS AND METHODS

One hundred full-leg standing radiographs of a previous study performed by our research group were reviewed [2]. The group consisted of 51 male and 49 female volunteers, aged between 20 and 27 years with no orthopaedic or trauma history of the lower limb. Their mean BMI was  $21.7 \pm 2.7$  (range 17.5-33.6). Twelve measurements were performed on the 200 knees (right and left knee) by one of the authors (LB) using the Lightbox software (6.1.5 UZL version A) allowing a measurement accuracy of  $0.1^\circ$ . Literature has shown a high intra- and inter-observer accuracy using this method [2, 4, 10, 18, 23].

We added a new perspective to the radiographic measurements by simulating the per-operative situation with an intramedullary rod, following the anatomical axis of the femur and a distal femoral cutting block seated against the medial condyle. This virtual joint line was created by drawing a line tangent to the medial condyle at an angle of  $96^\circ$  relative to the anatomical axis of the femur (fig 1). Furthermore we introduced two new distances, a femoral (CKJL) and a tibial (FTJL) one, to provide a more complete assessment of the joint line position.



**Figure 1:** Typical example of a close up view of a full limb standing radiograph. The ATJL, MEJL and CKJL are measured to a virtual joint line (red line). This virtual joint line was created by drawing a line tangent to the medial condyle at an angle of  $96^\circ$  relative to the anatomical axis of the femur. In this way, the actual intra-operative situation where an intramedullary rod with a distal femoral cutting block with a standard  $6^\circ$  valgus angle is introduced in the femoral canal, is mimicked. For explanation of the abbreviations, see materials and methods.

The following measurements were performed (fig1):

1. Hip-Knee-Ankle (HKA) angle: the angle formed by the mechanical axes of the femur and the mechanical axis of the tibia. It was expressed as a deviation of neutral alignment ( $180^\circ$ ): a negative value for varus alignment and a positive value for valgus alignment. A HKA angle of less than  $-3^\circ$  was considered a valgus deformity. A HKA angle of more than  $3^\circ$  was considered a varus deformity.
2. The leg length: Distance between the most proximal point of the femoral head to the central point of the tibiotalar joint at the distal tibia.
3. Mechanical lateral distal femoral angle (mLDFA): the angle formed between the mechanical femoral axis and the proximal joint line (the knee joint line of the distal femur).



4. Medial proximal tibial angle (MPTA): the angle formed between the mechanical tibial axis and the distal joint line (the knee joint line of the proximal tibia).
5. Femoral Width (FW): distance between the most external points of the medial and lateral epicondyles.
6. Distance from the medial epicondyle to the joint line (MEJL): perpendicular distance between the medial epicondyle and the virtual cutting block.
7. Distance from the lateral epicondyle to the joint line (LEJL): perpendicular distance between the lateral epicondyle and the femoral joint line.
8. Distance from the adductor tubercle to the joint line (ATJL): perpendicular distance between the adductor tubercle and the virtual cutting block. The adductor tubercle was identified on the radiograph as the distal point on the medial supracondylar slope [10, 15, 23].
9. Distance from the centre of the knee to the joint line (CKJL): distance from the intersection of a line connecting the adductor tubercle on the medial side to the distal point on the supracondylar slope on the lateral side to the virtual cutting block, following the virtual intramedullary guide.
10. Distance from the fibular head to the joint line (FHJL): Perpendicular distance between the most proximal point of the fibular head and the tibial joint line.
11. Distance from the fibular tubercle to the joint line (FTJL): The shortest distance between the most lateral point of the fibular head and the tibial joint line. This point was termed the fibular tubercle (FT).

The study protocol was approved by the Ethics Committee of the University of Leuven, Belgium.

#### Statistical analysis

A Pearson correlation test was used to evaluate the correlation between the ATJL, MEJL, LEJL and FTJL on the one hand and FW, CKJL, and the HKA-angle on the other hand. A two sided student t-test was used to explore the differences in measured distances between males and females. The variability of ratios has been compared using the SAS procedure PROC MIXED. More specifically, a multivariate normal model for the ratios assuming all variances to be equal is compared with a model where the variances are allowed to differ. The comparison is based on a likelihood-ratio test. All analyses have been performed using SAS software, version 9.2 of the SAS System for Windows.

## RESULTS

Of the 100 patients that we examined, 81 had neutral alignment, 4 had a valgus deformity and 15 patients had a varus deformity.

The average distance from the adductor tubercle perpendicular to the joint line (ATJL) was  $44.6 \pm 4.3$  mm (range, 32.1-54.8 mm). The absolute distances for all the joint line measurements and the differences between males and females are presented in table 1. For all these distances, a statistically difference was observed between males and females ( $p < 0.001$ ) except for the FHJL distance.

**Table 1:** The results of the different measured distances expressed as mean absolute values (mm) with standard deviation (between brackets). Our results are compared to the results in literature Statistical significant differences between males and females are indicated with \*.

Distance	Own Results			Griffen[8]	Servien[19]	Romero[18]	Iacono[10]
	Overall	Males	Females				
ATJL	44.6 ( $\pm$ 4.3)	47.5 ( $\pm$ 2.8)*	42.0 ( $\pm$ 3.5)*				48.7 ( $\pm$ 4.8)
MEJL	27.7 ( $\pm$ 3.0)	29.7 ( $\pm$ 2.5)*	26.6 ( $\pm$ 2.7)*	27.4 ( $\pm$ 2.9)	28.27 ( $\pm$ 2.59)	31.6 ( $\pm$ 2.5)	30.7 ( $\pm$ 3.9)
LEJL	27.1 ( $\pm$ 2.7)	28.1 ( $\pm$ 2.4)*	26.1 ( $\pm$ 2.6)*	25.0 ( $\pm$ 2.6)	23.00 ( $\pm$ 2.29)	25.1 ( $\pm$ 2.7)	
CKJL	43.3 ( $\pm$ 3.7)	45.9 ( $\pm$ 2.5)*	40.6 ( $\pm$ 3.9)*				
FHJL	15.1 ( $\pm$ 3.7)	15.0 ( $\pm$ 3.9)	14.9 ( $\pm$ 3.6)		14.11 ( $\pm$ 3.04)		16.7 ( $\pm$ 4.0)
FTJL	34.3 ( $\pm$ 3.9)	36.7 ( $\pm$ 3.2)*	32.9 ( $\pm$ 3.7)*				
FW	85.4 ( $\pm$ 7.1)	91.4 ( $\pm$ 4.1)*	79.7 ( $\pm$ 3.8)*	78.0 ( $\pm$ 6.7)	81.72 ( $\pm$ 6.93)	79.9 ( $\pm$ 6.5)	89.7 ( $\pm$ 8.4)

The Pearson correlation coefficient between the different distances and FW were calculated. A strong correlation can be found between ATJL and FW ( $r=0.82$ ) and between the CKJL and the FW ( $r=0.86$ ) (table 2). The relationship between the FW on one side and the MEJL ( $r=0.59$ ) and LEJL ( $r=0.59$ ) on the other side was found to be weaker. The correlation between the ATJL and the FW is represented in figure 2. Furthermore, we found an excellent correlation between the ATJL and the CKJL ( $r=0.95$ ). The Pearson correlations between the different distances and the alignment (HKA-angle) showed a weak relationship with  $r=0.08$  (n.s.) for the HKA-angle and ATJL,  $r=0.01$  (n.s.) for the HKA-angle and MEJL and  $r=0.13$  ( $p=0.08$ ) between the HKA-angle and LEJL. None of this correlations is statistical significant different in the different alignment categories. On the tibial side, the correlation between the FHJL and the FW was found to be 0.13. The correlation between the FTJL was 0.58. Finally, the correlation between the leg length and the different distances was

investigated. This relationship was significant, although less strong. An overview of the correlations can be found in table 2.

**Table 2:** The calculated Pearson correlation between the measured distances and the femoral width (FW), the hip-knee-ankle (HKA) angle and the length of the whole limb. P values are indicated between brackets.

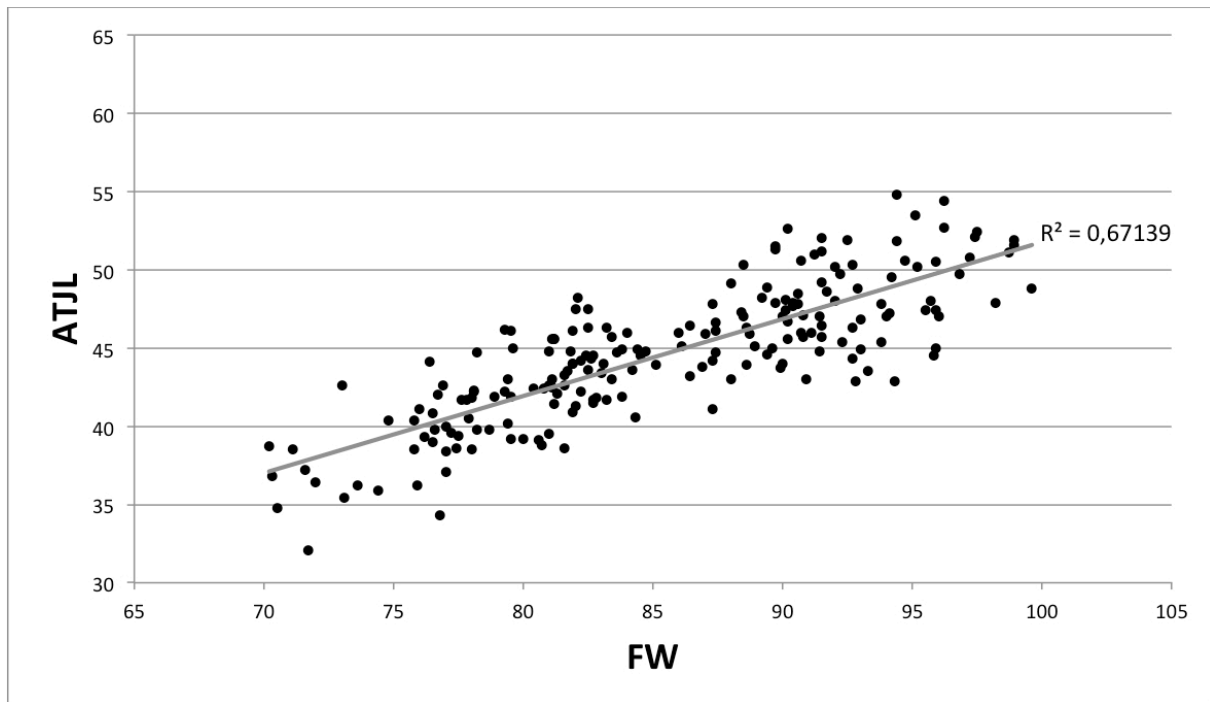
Correlations	FW	HKA- angle	Length
<b>ATJL</b>	0.82 (<0.0001)	0.08 (n.s.)	0.72 (<0.0001)
<b>MEJL</b>	0.59 (<0.0001)	0.01 (n.s.)	0.44 (<0.0001)
<b>LEJL</b>	0.59 (<0.0001)	0.13 (n.s.)	0.53 (<0.0001)
<b>CKJL</b>	0.86 (<.0001)	0.07 (n.s.)	
<b>FTJL</b>	0.58 (<0.0001)	0.03 (n.s.)	0.67 (<0.0001)

Based on these results, we found the adductor ratio, defined as the ATJL divided by the FW, to be 0.52 (SD 0.027). The ratio of the CKJL to the FW was found to be 0.51 (SD 0.022). The other calculated ratios are represented in table 3. A pairwise comparison of the standard deviation of the MEJL/FW, LEJL/FW and CKJL/FW ratio revealed no significant differences. A significant difference ( $p < 0.0001$ ) was found between the ATJL/FW and the CKJL/FW ratios with the CKJL/FW ratio showing the lowest variance. Also significant differences were found between males and females for the LEJL/FW, CKJL/FW and FHJL/FW ratio ( $p < 0.01$ ).

**Table 3:** The different measured distances expressed as a ratio to the femoral width (FW) with standard deviation between brackets. Significant differences between males and females are indicated with \*.

Ratio with FW	Overall (n=100)	Females (n=49)	Males (n=51)	p value
<b>ATJL/FW</b>	0.52 ( $\pm$ 0.029)	0.53 ( $\pm$ 0.030)	0.52 ( $\pm$ 0,024)	n.s.
<b>MEJL/FW</b>	0.32 ( $\pm$ 0.027)	0.33 ( $\pm$ 0.026)	0.32 ( $\pm$ 0.026)	n.s.
<b>LEJL/FW</b>	0.32 ( $\pm$ 0.029)	<b>0.33 (<math>\pm</math> 0.026)*</b>	<b>0.31 (<math>\pm</math> 0.023)*</b>	<b>0.0001</b>
<b>CKJL/FW</b>	0.50 ( $\pm$ 0.027)	<b>0.51 (<math>\pm</math> 0.024)*</b>	<b>0.50 (<math>\pm</math> 0.018)*</b>	<b>0.01</b>
<b>FHJL/FW</b>	0.19 ( $\pm$ 0.044)	<b>0.20 (<math>\pm</math> 0.044)*</b>	<b>0.18 (<math>\pm</math> 0.045)*</b>	<b>0.01</b>
<b>FTJL/FW</b>	0.40 ( $\pm$ 0.037)	0.41 ( $\pm$ 0.037)	0.40 ( $\pm$ 0.035)	n.s.

By using the adductor ratio, a virtual reconstruction of the joint line within 2 mm of its original level was performed in 64% of the cases and within 4 mm in 92% of the cases. The use of the CKJL/FW ratio elevated this accuracy to even to 72% and 97% respectively.



**Figure 2:** Scatter plot of the ATJL against the FW. A linear correlation with a  $R^2$  of 0.671 is observed. For explanation of the abbreviations, see materials and methods.

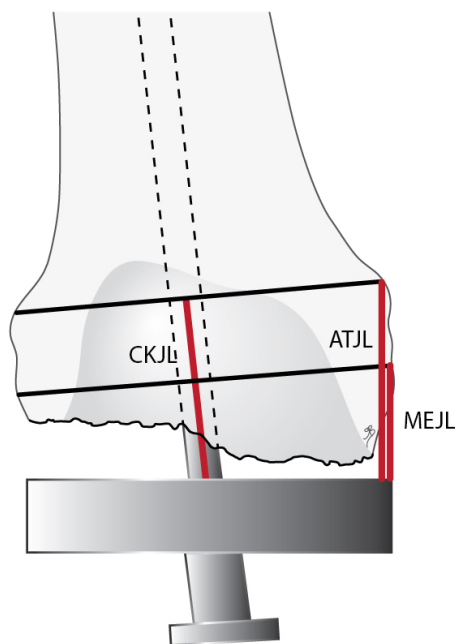
## DISCUSSION

The most important finding of this study was the fact that the adductor ratio was found to be an accurate and reliable tool for joint line reconstruction in revision TKA.

Typically, the joint line is said to be located at a point 1.5 cm cranial to the tip of the fibular head, 2 cm to 2.5 cm caudal to the lateral femoral epicondyle or 2.5 cm to 3 cm caudal to the medial femoral epicondyle [1, 19]. Our results showed values for the medial epicondyle, the lateral epicondyle, the adductor tubercle and the fibular head of 27.7 mm (SD 3.0), 27.1 mm (SD 2.7), 44.6 mm (SD 4.3) and 15.1 mm (SD 3.7) respectively. These measurements were performed on calibrated full limb radiographs. In this way, these absolute values can be immediately applied in clinical practice. This is an advantage over previous studies using MRI as measurements on MRI images cannot always be transferred to radiograph distances and clinical practice. Moreover, the radiographs were obtained from healthy volunteers with no prior orthopaedic history thereby eliminating any selection bias.

This study represents the most complete assessment of joint line position in literature as it also included the adductor tubercle as landmark, introduced two new measurements (CKJL, FTJL) and took in account the overall limb alignment. The CKJL was actually found to be the most reliable femoral distance of all. On the tibial side, the tip of the fibula is known to be unreliable as reference landmark due to a high inter-individual variation [17, 19]. The fibular tubercle was much more reliable as tibial landmark as it showed significant lower inter-individual variation. However the downside of these two new distances is that they can only be determined intra-operatively by using fluoroscopy.

The methodology of the measurements of the MEJL, ATJL and CKJL was slightly changed from previous studies in that measurements were made to a virtual joint line. This virtual joint line was created by drawing a line tangent to the medial condyle at an angle of  $96^\circ$  relative to the anatomical axis of the femur (fig 1). In this way, the actual intra-operative situation where an intramedullary rod with a distal femoral cutting block with a standard  $6^\circ$  valgus angle is introduced in the femoral canal, is mimicked (fig 3). This produces data that can be directly applied to a typical revision situation.



**Figure 3:** A typical revision case with distal femoral bone loss. As the intramedullary rod with the distal femoral cutting block has been introduced, the calculated distances (ATJL, MEJL, CKJL) can be used intra-operatively to reconstruct the joint line at its original level. For explanation of the abbreviations, see materials and methods.

The major downside of the use of these absolute distances is the large variation in these distances that has been described, compromising their potential as landmark for joint line reconstruction. A part of this variation can be attributed to size differences and gender. In order to account for size differences, Servien et al. they described a ratio of the distance from the epicondyles to the joint line,

to the femoral width. By dividing the absolute values of the distances by the femoral width, the ratio becomes relative size independent. They found the ratio of the distance from the lateral epicondyle to the joint line to the femoral width to be 0.28 and 0.34 for the medial epicondyle [19]. The inter-individual variation for these ratios is much smaller. As proof of that, we found different absolute values for the measured distances when compared to previous reports. However, the calculated ratios were very similar (table 4). This means that the differences in the distances from the bony landmarks to the joint line between different individuals can mostly be attributed to differences in size between their knees. The use of this ratio to the femoral width produces a size independent and more constant value. Hence, the joint line position relative to the epicondyles can be calculated with this ratio by measuring the femoral width on the pre-operative radiograph or intra-operatively and multiplying it with the ratio (eg FW x 0.32 for the medial epicondyle). The major problem with this method, which makes it difficult in use, is that the intra-operative localisation of the medial and lateral epicondyle is quite inaccurate [13, 21].

**Table 4:** The different measured distances expressed as a ratio to the femoral width (FW) and compared to the results in literature. Values indicated with \* are females, ° are males.

Ratio with FW	Own Results	Griffen	Servien	Romero	Iacono
<b>ATJL/FW</b>	<b>0.52</b>				0.543
<b>MEJL/FW</b>	<b>0.32</b>	0.36*/0.35°	0.34	0.395	0.343
<b>LEJL/FW</b>	<b>0.32</b>	0.32*/0.31°	0.28	0.315	
<b>CKJL/FW</b>	<b>0.50</b>				
<b>FHJL/FW</b>	<b>0.18</b>		0.17		
<b>FTJL/FW</b>	<b>0.40</b>				

Recently, the adductor tubercle has been described as a reliable landmark for determining joint line position [10]. Also for this landmark, a strong correlation ( $R=0.82$ ) with the femoral width can be observed meaning that a lot of the observed variation in the ATJL can be attributed to a variation of the FW. The ratio of the ATJL to the FW is in other words relative size independent. Moreover when compared to the epicondyles, the intra-operative localisation of the adductor tubercle by palpation [11] or by fluoroscopy is easier, making it a valuable landmark for joint line reconstruction in revision TKA. Even in heavy revision cases where the epicondyles can no longer be found, the adductor ratio remains an identifiable landmark. Secondly, the correlation between the ATJL and the FW was found

to be stronger than the correlation between the MEJL and the FW. This means a stronger linear relationship and thus a more constant value with lower spread.

Therefore, the adductor ratio is perfectly suited to calculate the joint line position in revision TKA. As a practical approach, the femoral width is measured on the pre-operative calibrated full-limb X-ray. Alternatively, a radiograph of the contralateral side can be used or the femoral width can be measured intra-operative. As a rule of thumb, the femoral width is then multiplied with 0.52 ( $ATJL = FW \times 0.52$ ). This calculated distance is then measured from the adductor tubercle to the cutting block that has been inserted with a  $6^\circ$  distal cutting angle relative to the intramedullary rod (fig 3). Fixation of the cutting block at this level will automatically reconstruct the joint line at its original level. Modern instrumentation techniques will allow you to immediately select the appropriate size distal femoral augment to reconstruct this joint level.

The major limitation of this study is the lack of data on the intra-operative accuracy and reproducibility in locating the adductor tubercle. As an alternative, fluoroscopy can be used to identify the bony landmarks as in medial patellofemoral ligament reconstruction where it has clearly shown its advantage. In our point of view, the downsides of the intra-operative use of fluoroscopy do not outweigh the advantage of an accurate joint line reconstruction, as this remains the key to a good functional result.

## CONCLUSION

The adductor ratio was found to be a reliable and accurate tool to reconstruct the joint line at its original level in revision TKA. Further research will be needed to evaluate the accuracy and the reproducibility of the intra-operative localisation of this reference point.

## REFERENCES

1. Bellemans J (2004) Restoring the joint line in revision TKA: does it matter? *Knee* 11:3–5
2. Bellemans J, Colyn W, Vandenuecker H, Victor J (2012) The Chitranjan Ranawat award: is neutral mechanical alignment normal for all patients? The concept of constitutional varus. *Clin Orthop Relat Res* 470:45–53

3. Bieger R, Huch K, Kocak S, Jung S, Reichel H, Kappe T (2014) The influence of joint line restoration on the results of revision total knee arthroplasty: comparison between distance and ratio-methods. *Arch Orthop Trauma Surg* 134:537–541
4. Colebatch AN, Hartb DJ, Zhaib G, Williamsb FM, Spectorb TD, Ardena NK (2009) Effective measurement of knee alignment using AP knee radiographs. *Knee* 16:42–45
5. Cope MR, O'Brien BS, Nanu AM (2002) The influence of the posterior cruciate ligament in the maintenance of joint line in primary total knee arthroplasty: a radiologic study. *J Arthroplasty* 17:206–208
6. Ensini A, Catani F, Biasca N, Belvedere C, Giannini S, Leardini A (2012) Joint line is well restored when navigation surgery is performed for total knee arthroplasty. *Knee Surg Sports Traumatol Arthrosc* 20:495–502
7. Figgie 3rd HE, Goldberg VM, Heiple KG, Moller 3rd HS, Gordon NH (1986) The influence of tibial-patellofemoral location on function of the knee in patients with the posterior stabilized condylar knee prosthesis. *J Bone Joint Surg Am* 68:1035–1040
8. Griffin FM, Kevin Math A, Giles R, Scuderi B, John N, Insall B, Poilvache PL, Math K, Scuderi GR, Insall JN (2000) Anatomy of the epicondyles of the distal femur: MRI analysis of normal knees. *J Arthroplasty* 15:354–359
9. Havet E, Gabrion A, Leiber-Wackenheim F, Vernois J, Olory B, Mertl P (2007) Radiological study of the knee joint line position measured from the fibular head and proximal tibial landmarks. *Surg Radiol Anat* 29:285–289
10. Iacono F, Lo Presti M, Bruni D, Raspugli GF, Bignozzi S, Sharma B, Marcacci M (2013) The adductor tubercle: a reliable landmark for analysing the level of the femorotibial joint line. *Knee Surg Sports Traumatol Arthrosc* 21:2725–9
11. Iacono F, Raspugli GF, Bruni D, Filardo G, Zaffagnini S, Luetzow WF, Lo Presti M, Akkawi I, Muccioli GMM, Marcacci M (2013) The adductor tubercle as an important landmark to determine the joint line level in total knee arthroplasty: from radiographs to surgical theatre. *Knee Surg Sports Traumatol Arthrosc* doi 10.1007/s00167-013-2809-0
12. Jawhar A, Shah V, Sohoni S, Scharf HP (2013) Joint line changes after primary total knee arthroplasty: navigated versus non-navigated. *Knee Surg Sports Traumatol Arthrosc* 21:2355–2362
13. Jerosch J, Peuker E, Philipps B, Filler T (2002) Interindividual reproducibility in perioperative rotational alignment of femoral components in knee prosthetic surgery using the transepicondylar axis. *Knee Surg Sports Traumatol Arthrosc* 10:194–197
14. Kawamura H, Bourne RB (2001) Factors affecting range of flexion after total knee arthroplasty. *J Orthop Sci* 6:248–252
15. LaPrade RF, Engebretsen AH, Ly T V, Johansen S, Wentorf F a, Engebretsen L (2007) The anatomy of the medial part of the knee. *J Bone Joint Surg Am* 89:2000–2010
16. Martin JW, Whiteside L a (1990) The influence of joint line position on knee stability after condylar knee arthroplasty. *Clin Orthop Relat Res* 259:146–156
17. Partington PF, Sawhney J, Rorabeck CH, Barrack RL, Moore J (1999) Joint line restoration after revision total knee arthroplasty. *Clin Orthop Relat Res* 367:165–171
18. Romero J, Seifert B, Reinhardt O, Ziegler O, Kessler O (2010) A useful radiologic method for preoperative joint-line determination in revision total knee arthroplasty. *Clin Orthop Relat Res* 468:1279–1283
19. Servien E, Viskontas D, Giuffrè BM, Coolican MRJ, Parker DA (2008) Reliability of bony landmarks for restoration of the joint line in revision knee arthroplasty. *Knee Surg Sports Traumatol Arthrosc* 16:263–269
20. Snider MG, Macdonald SJ (2009) The influence of the posterior cruciate ligament and component design on joint line position after primary total knee arthroplasty. *J Arthroplasty* 24:1093–1098
21. Stoeckl B, Nogler M, Krismer M, Beimel C, de la Barrera J-LM, Kessler O (2006) Reliability of the transepicondylar axis as an anatomical landmark in total knee arthroplasty. *J Arthroplasty* 21:878–882
22. Weber P, Schröder C, Laubender RP, Baur-Melnyk A, von Schulze Pellengahr C, Jansson V, Müller PE (2013) Joint line reconstruction in medial unicompartmental knee arthroplasty: development and validation of a measurement method. *Knee Surg Sports Traumatol Arthrosc* 21:2468–2473
23. Wijdicks CA, Griffith CJ, LaPrade RF, Johansen S, Sunderland A, Arendt E a, Engebretsen L (2009) Radiographic identification of the primary medial knee structures. *J Bone Joint Surg Am* 91:521–529



## 2.1.2 THE ORIENTATION OF THE JOINT LINE IN THE OSTEO-ARTHRITIC KNEE

**T Luyckx, F Vanhoorebeeck, L Luyckx, J Bellemans**

End stage osteo-arthritis does not change the joint line orientation of the knee.

*Submitted to the journal of Clinical Orthopaedics and Related Research*

### ABSTRACT

#### **Background**

We previously described the coronal alignment and the joint line (JL) orientation in healthy individuals. The JL orientation in the osteo-arthritic (OA) knee remains poorly defined. It is however the main determinant of the coronal alignment and significantly affects component placement in total knee arthroplasty (TKA).

#### **Purpose:**

The purpose of this study was to describe the JL orientation in the OA knee, to determine its relationship with the coronal alignment and to compare it with the normal knee.

#### **Methods:**

Full-leg standing digital radiographs were performed in a cohort of 561 patients with primary osteo-arthritis and in a cohort of 250 asymptomatic adult volunteers. Hip-knee-ankle angle (HKA), tibial and femoral joint line angles were measured. Patients were subdivided in valgus ( $HKA < 3^\circ$ ), neutral and varus ( $HKA > 3^\circ$ ).

#### **Results**

In the OA cohort, the orientation of the tibial JL averaged  $2.9^\circ$  of varus (SD 3.8). The orientation of the femoral JL was on average  $2.0^\circ$  of valgus (SD 2.9).

The orientation of the tibial and femoral JL was significantly different in the different alignment groups. Varus knees had a varus tibial JL ( $4.9^\circ$ ) with a neutral femoral JL ( $-0.6^\circ$ ). Valgus knees had a neutral tibial JL ( $-0.6^\circ$ ) with a valgus femoral JL ( $-4.8^\circ$ ). In the neutral knee a combination of a slight varus tibial JL ( $1.6^\circ$ ) with a slight valgus femoral JL ( $-2.6^\circ$ ) was seen.

The orientation of the femoral and tibial JL in varus and valgus knees showed no statistical differences between the normal and OA knees.

The increase in HKA angle with the progression of the OA process was solely the consequence of an increase in the JLCA.

**Conclusion**

The orientation of the joint line was not altered by the OA process in varus and valgus knees. The increase in HKA angle of OA knees was solely the consequence of wear and joint space opening. Bone loss was minimal. Therefore, the joint line of the OA knee is a reliable landmark for anatomic joint line reconstruction in TKA.

**Level of Evidence:**

Therapeutic study, Level III

**INTRODUCTION**

Geometry, orientation and position of the tibiofemoral joint interface determine knee function. This is intimately related to knee kinematics, kinetics and stability. The tibiofemoral joint interface is shaped to work in synergy with the ligaments that surround the knee, some of which are isometric in nature, some not [32]. This complex interaction between ligaments and joint interface is still insufficiently understood and remains a major challenge for ligament and joint reconstruction. In the field of knee arthroplasty, the joint interface has often been called the 'joint line' (JL), which is a significant two-dimensional simplification of the complex three-dimensional characteristics, induced by a 'radiological' visualization of the joint. Still, this simplified two-dimensional description of the three-dimensional reality offers the advantage of practicality in daily use in both the osteo-arthritic (OA) and replaced knee.

The current knowledge of the morphology of the JL in the coronal plane is mainly limited to the normal knee [3, 6–8, 18, 24, 27]. This JL orientation is the major determinant of both the coronal limb alignment and load distribution of the knee [16]. The relationship between the JL orientation and the mechanical lower limb alignment (HKA-angle) is defined by the sum of the tibial and femoral joint line angle (TJLA and FJLA) and the joint line convergence angle (JLCA):  $HKA = TJLA + FJLA + JLCA$  (fig 1) [10]. The joint line convergence angle represents the divergence of the tibial and femoral joint surface and is the result of wear and joint space opening. In the healthy knee, the orientation of the tibial joint line is oriented in approximately 3° of varus relative to the mechanical axis of the tibia and the orientation of the femoral JL is in approximately 3° of valgus relative to the mechanical axis of the femur [3, 6–8, 24, 27]. However, these are average value showing a large variance in the population. There are for instance significant differences in JL orientation between normal varus, neutral and valgus knees [3].

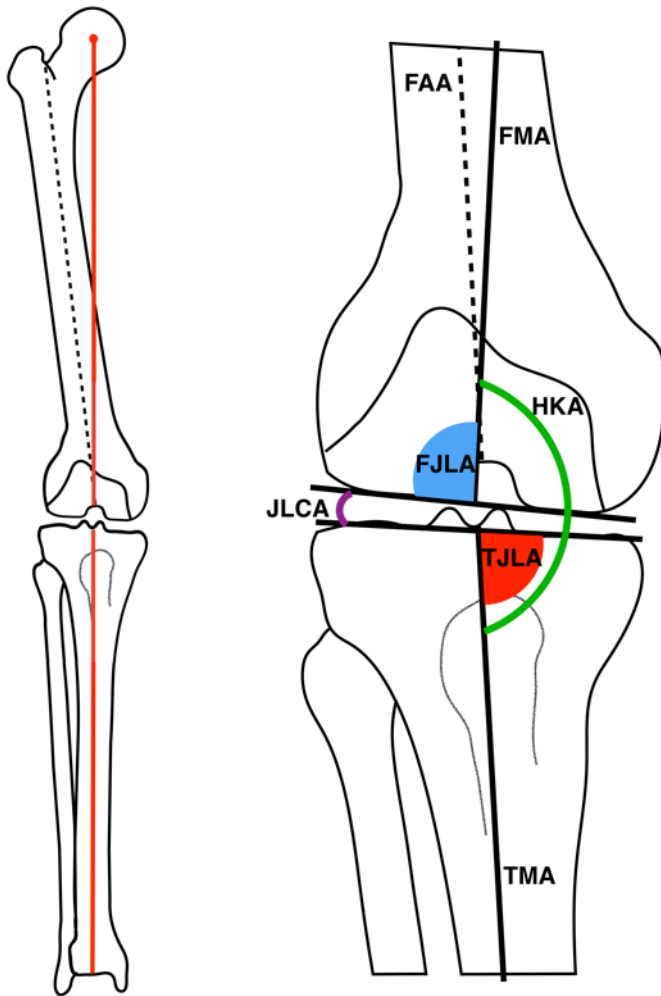
Data on the JL orientation in the OA knee are more sparse [20, 22, 33]. Many surgeons assume that with the progression of OA, progressive varus or valgus malalignment occurs due to changes in the JL orientation of the knee. However, evidence is lacking. Therefore, a better understanding of the joint line orientation in the OA-knee is critical for a better understanding of knee osteo-arthritis onset and progression. It is also crucial information for the planning of surgical interventions. In the case of a corrective osteotomy, the site of the deformity (femoral or tibial, sometimes both) needs to be identified and addressed. Failure to do so will result in JL obliquity. In total knee arthroplasty (TKA), understanding the JL orientation of the OA knee is important for placement of the femoral and tibial component, as this component placement will determine limb alignment and correction after TKA.

The purpose of this study was therefore to describe the distribution of the JL orientation relative to the mechanical axis of femur and tibia in the OA knee, compare it to the normal knee and investigate its relationship with the HKA-angle. The hypothesis was that JL orientation in the OA knee would be similar with that of the normal knee, and that there would be a significant relationship with the HKA-angle.

## MATERIALS AND METHODS

Two cohorts of patients were studied. The first cohort consisted of 561 consecutive patients who underwent a posterior stabilised TKA at our service between 2009 and 2010. All patients undergoing a TKA during that period were prospectively included in our knee arthroplasty database. Selection criteria were applied to these 657 patients. Only the patients with primary osteoarthritis as indication were selected (609). Patients with rheumatoid arthritis or posttraumatic osteoarthritis were excluded (48). 22 cases were excluded because radiographs were not taken according to Paley's criteria [28]. Twenty-six patients with a fixed flexion deformity were excluded. Of those, 12 patients had a grade four OA according to Ahlbäck's classification [1]. As a result of all these selection criteria, our working database consisted of 561 OA knees.

The second cohort consisted of 250 healthy volunteers on whom we reported in a previous article [3]. The study protocol was approved by the local Ethics Committee.



**Figure 1:** Schematic representation of the different measurements that were performed. All joint line measurements were made relative to the mechanical axis of the femur and tibia. FAA: femur anatomical axis, FMA: femur mechanical axis, TMA: tibia mechanical axis, HKA: hip-knee-ankle angle, FJLA: femoral joint line angle, TJLA: tibial joint line angle, JLCA: joint line convergence angle.

Full-leg standing digital radiographs were obtained of all knees. The weight-bearing full-leg radiographs, which included the whole pelvis, were obtained with the patient standing while ensuring that the patellae were oriented forwards, as we described previously [3]. These radiographs were calibrated and all measurements were performed using the AGFA Picture Archive and Communication System (PACS) (Agfa- Gevaert, Mortsels, Belgium). Alignment of the leg was determined based on these radiographs. Femoral and tibial mechanical axes were defined according to the criteria defined by Cooke et al [10]. The hip centre was obtained using concentric Moose circles. The pre-operative centre of the knee was determined as the intersection of the midline between the tibial spines and the midline between the femoral condyles and tip of the tibia. The

centre of the ankle was determined as the mid-width of the talus. Using these three points, the hip-knee-ankle (HKA) angle of the lower leg could be calculated. The HKA angle was defined as the angle formed by the mechanical femoral axis and the mechanical tibial axis. The HKA angle was expressed as a deviation from 180° with a negative value for valgus and positive value for varus alignment. The lateral angle formed between the mechanical femoral axis and the knee joint line of the distal femur was defined as the femoral joint line (FJL) orientation. The tibial joint line (TJL) angle was defined as the medial angle formed between the mechanical tibial axis and the knee joint line of the proximal tibia. Both FJL and TJL angles were expressed as deviation from 90° with negative value for valgus and positive value for varus. The angle between the knee joint lines of the distal femur and proximal tibia was called the joint line convergence angle (JLCA). An independent observer (FV) performed the radiographic measurements within a range of accuracy of 0.1°. Literature has shown a high intra- and inter-observer accuracy using this method [34, 35, 36].

The patients were subdivided into three categories, based on their HKA angle: HKA angle > 3° = varus; - 3° ≤ HKA angle ≤ 3° = neutral; HKA angle < - 3 = valgus.

According to the pre-operative alignment, there were 305 varus knees (54.4%), 137 neutral knees (24.4%) and 119 valgus knees (21.2%). 214 patients were male (38%), 347 were female (62%). The demographic variables are presented in table 1.

**Table 1:** Demographic variables of the OA cohort. Absolute values are presented with standard deviation. (\*) indicates a statistical significant difference between valgus and varus knees ( $p < 0.01$ )

Variable	Valgus (n=119)	Neutral (n=137)	Varus (n=305)
<b>Age (years)</b>	67.8 ± 11.9	65.4 ± 12.1	67.3 ± 10.2
<b>Gender</b>			
Female	76.2%*	66.4%	52.1%*
Male	23.8%*	33.6%	47.9%*
<b>BMI</b>	27.7 ± 4.8	27.3 ± 5.8	30.4 ± 4.3

*Statistical analysis*

The groups were compared with  $\chi^2$ -test (or Fisher's exact tests) and Mann-Whitney U tests (Kruskal-Wallis for the comparison of more than two groups). Associations between variables are verified with Spearman correlations. P-values smaller than 0.01 are considered significant. All analyses have been performed using SAS software, version 9.2 of the SAS System for Windows (SAS Institute Inc., Cary, NC, USA).

**RESULTS**

The mean HKA angle of the OA knee was 3.3° (SD 7.3) of varus. The orientation of the tibial joint line (TJL) was found to average 2.9° of varus (SD 3.8). The orientation of the femoral joint line (FJL) was on average 2.0° of valgus (SD 2.9).

The HKA-angle was on average -7.1° (SD 3.4) in valgus OA knees, 0.2° (SD 1.8) in neutral OA knees and 8.7° (SD 3.8) in varus OA knees ( $p < 0.001$ ).

The orientation of the tibial and femoral joint line was significantly different in the different alignment groups ( $p < 0.01$ ) (table 2). Varus knees had a varus tibial joint line (4.9°) with a neutral femoral joint line (-0.6°) (fig 2). Valgus knees had a neutral tibial joint line (-0.6°) with a valgus femoral joint line (-4.8°) (fig 3). In the neutrally aligned knee a slight varus of the tibial joint line (1.6°) with a slight valgus of the femoral joint line (-2.6°) was found (fig 4).

A strong linear correlation was found for the orientation of the tibial and the femoral joint line with the coronal alignment ( $R^2 = 0.49951$  and  $R^2 = 0.42548$ ) (fig 5 and fig 6). For every degree change in HKA angle from valgus to varus, a -0.4° change in tibial joint line and a +0.3° change in femoral joint line was observed.

Data were compared to the joint line orientation in the normal knee (table 3). No statistically significant differences were observed in the orientation of the tibial and femoral JL between varus and valgus knees. There was a significant difference in the HKA angle and the JLCA ( $p < 0.01$ ). The major contribution to the increase in HKA angle in varus and valgus knees when progressing from normal to OA was made by the JLCA (84% contribution in valgus knees, 93% contribution in varus knees).

**Table 2:** The different alignment and joint line measurements subdivided according to the HKA angle in valgus, neutral and varus knees. HKA = Hip Knee Ankle angle, FJLA = Femoral Joint Line Angle, TJLA = Tibial Joint Line Angle, JLCA = Joint Line Convergence Angle. Data are represented as means with standard deviation. A statistical significant difference was found between all measurements ( $p < 0.01$ ).

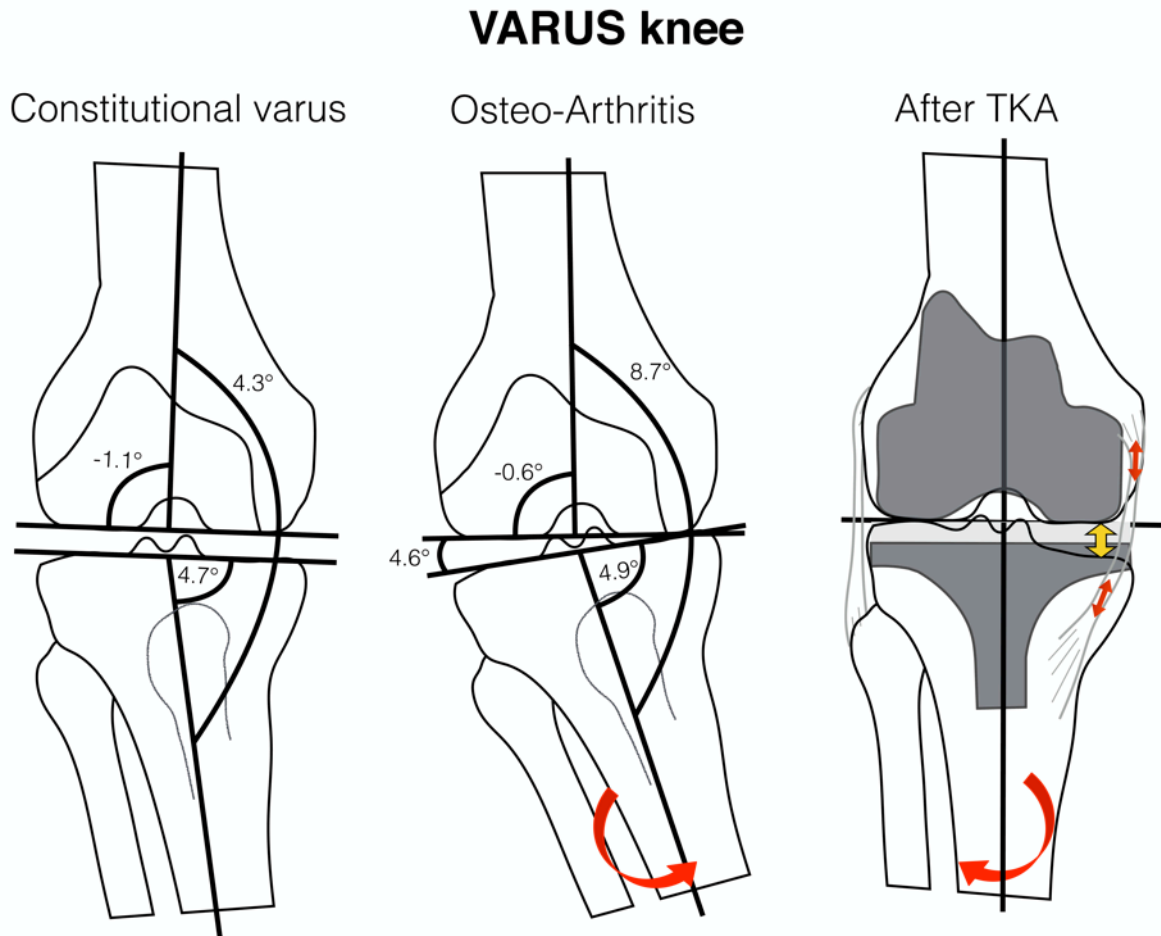
Variable	HKA-angle			Pairwise comparisons			
	Valgus (1)	Neutral (2)	Varus (3)	P-value	1 vs 2	1 vs 3	2 vs 3
HKA	-7.1 (3.4)	0.2 (1.8)	8.7 (3.8)	<.001	<.001	<.001	<.001
FJLA	-4.8 (2.7)	-2.6 (1.8)	-0.6 (2.4)	<.001	<.001	<.001	<.001
TJLA	-0.6 (2.6)	1.6 (2.4)	4.9 (3.4)	<.001	<.001	<.001	<.001
JLCA	-2.3 (1.8)	2.3 (1.6)	4.6 (2.4)	<.001	<.001	<.001	<.001

**Table 3:** Pairwise comparison of the different alignment and joint line measurements in the normal and the osteo-arthritic (OA) knee. A subdivision according to the HKA angle in valgus, neutral and varus knees was made. HKA = Hip Knee Ankle angle, FJLA = Femoral Joint Line Angle, TJLA = Tibial Joint Line Angle, JLCA = Joint Line Convergence Angle, Delta = mean difference between the normal and the OA knee. Data are represented as means with standard deviation. In varus and valgus knees, no difference was noted in the JL orientation between normal and OA knees.

Variable	HKA angle								
	Valgus			Neutral			Varus		
	Normal (1)	OA (2)	Delta	Normal (3)	OA (4)	Delta	Normal (5)	OA (6)	Delta
HKA	-3.5 (0.2)	-7.1 (3.4)	3.7	0.5 (1.6)	0.2 (1.8)	0.3	4.3 (0.8)	8.7 (3.8)	4.4
FJLA	-4.6 (0.8)	-4.8 (2.7)	0.2	-2.4 (1.6)	-2.6 (1.8)	0.2	-1.1 (1.6)	-0.6 (2.4)	0.5
TJLA	0.4 (1.1)	-0.6 (2.6)	1.1	2.5 (1.7)	1.6 (2.4)	0.9	4.7 (1.8)	4.9 (3.4)	0.1
JLCA	-0.8 (0.6)	-2.3 (1.8)	3.1	-0.6 (1.0)	2.3 (1.6)	2.8	-0.5 (1.0)	4.6 (2.4)	5.1

Pairwise comparisons

1 vs 2	3 vs 4	5 vs 6
<0.01	n.s.	<0.01
ns	n.s.	n.s.
ns	P < 0.01	n.s.
<0.01	P < 0.01	<0.01

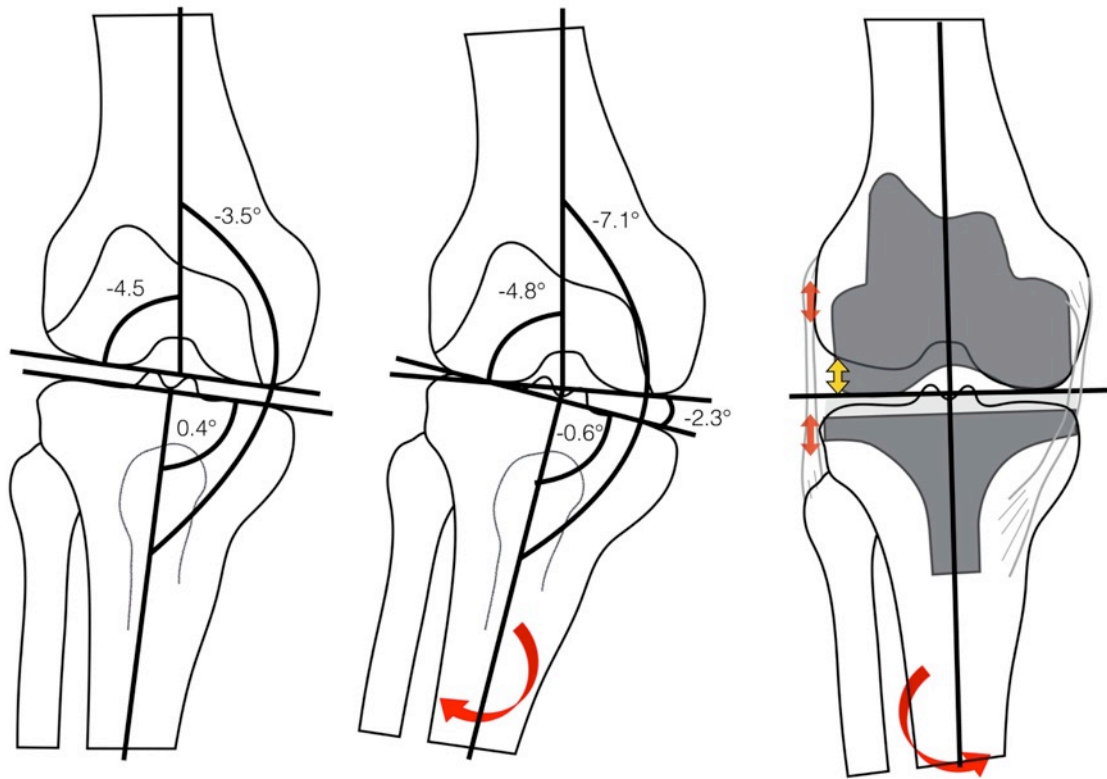


**Figure 2:** Schematic representation of the joint line (JL) orientation in the varus knee. Mean values are presented. A: JL orientation in the healthy constitutional varus knee. B: JL orientation in the osteo-arthritic varus knee. Note that there are no significant differences in the JL orientation of femur and tibia. The increase in divergence of the tibial and femoral joint line (=joint line convergence angle) is responsible for the increase in HKA angle. C: A mechanically aligned TKA with a perpendicular JL will change the tibial JL orientation to correct the alignment. This will cause overstuffing of the medial compartment by under-resection of the medial tibial plateau. A release of the MCL will be required in many cases.



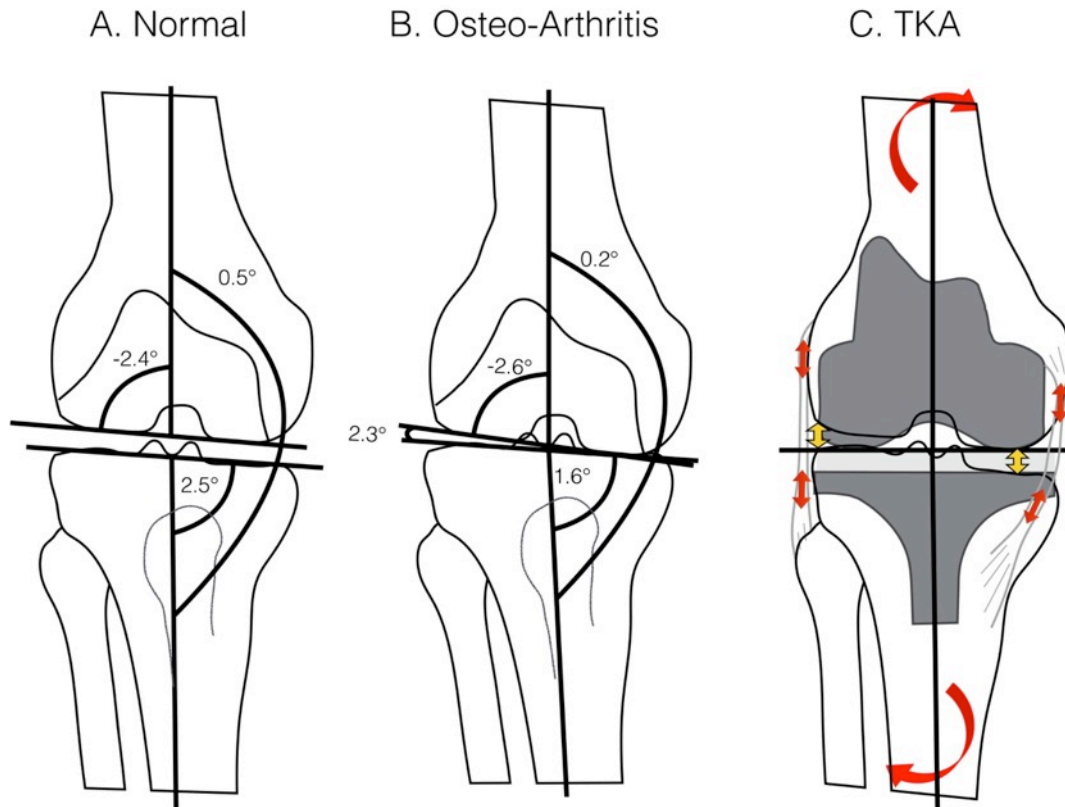
## VALGUS knee

A. Constitutional valgus    B. Osteo-Arthritis    C. After TKA



**Figure 3:** Schematic representation of the joint line (JL) orientation in the valgus knee. Mean values are presented. A: JL orientation in the healthy constitutional valgus knee. B: JL orientation in the osteo-arthritic valgus knee. Note that there are no significant differences in the JL orientation of femur and tibia. The increase in divergence of the femoral and tibial joint line (=joint line convergence angle) is responsible for the increase in HKA angle. C: A mechanically aligned TKA with a perpendicular JL will change the femoral JL orientation to correct the alignment. This will cause overstuffing of the lateral compartment by under-resection of the lateral distal femur. A release of the posterolateral capsule will be required in many cases.

## NEUTRAL knee



**Figure 4:** Schematic representation of the joint line (JL) orientation in the neutral knee. Mean values are presented. A: JL orientation in the healthy neutral knee. B: JL orientation in the osteo-arthritic neutral knee. Note that there are no significant differences in the JL orientation of femur. The JL orientation on the tibia was significantly different C: A mechanically aligned TKA with a perpendicular JL will change the orientation of the femoral and tibial JL. This will result in a slightly distalised lateral femoral joint line and slight build-up on the medial proximal tibia. Both might require a release to correct for ligament tightness.

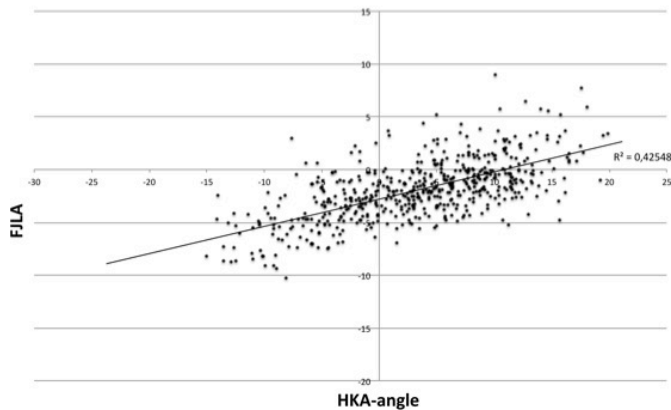
## DISCUSSION

The purpose of this study was to define the joint line orientation in the OA knee. This is critical information as orientations of the tibial and femoral JL determine the coronal limb alignment:  $HKA = TJLA + FJLA + JLCA$  (fig 1)[10]. Generally, a varus inclination of  $3^\circ$  of the tibial joint line and a valgus inclination of  $3^\circ$  of the femoral joint line is assumed [24]. Together, these result in a neutrally aligned limb with a JL parallel with the ground during stance [28].

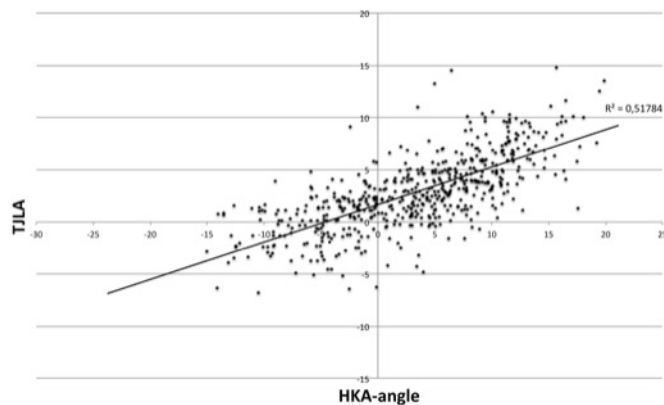
Recently, limb alignment and the joint line orientation were investigated in a large cohort of healthy subjects [3]. These data provided critical insight in the distribution and mean values of coronal limb alignment in the healthy population. A cohort of patients with varus at the end of growth was identified and termed constitutional varus. JL orientation in these constitutional varus patients was shown to be different from the JL orientation in the neutral and valgus aligned knees. With constitutional varus, more varus orientation of the tibial JL is required to achieve a JL parallel to the ground [33]. The opposite is true for the valgus knee. Recently, the relationship of the tibial JL with the ground was investigated in a large cohort of OA patients. It was shown that with the onset of symptomatic knee osteo-arthritis, the parallelism with the ground of the tibial joint line is progressively lost [33]. Despite these data, a systematic understanding of the mean values and variance in the population of the JL orientation in the OA knee is lacking.

This study has several limitations. First, the OA cohort consisted of patients planned for TKA and thus patients with end stage knee OA. As such it was a population with more severe complaints than the general OA population and might be associated with more severe deformation. On the other hand, it was our intention to look into these patients as they represent the population of interest toward planning of joint line reconstruction in TKA. Second, selection bias might have been introduced by excluding 12 patients with stage 4 osteo-arthritis according to Ahlbäcks' classification. They were excluded because of a fixed flexion contracture that made the JL measurements in these patients impossible. The 12 patients represented only 2.1% of the population so the effect was small. Also patients with fixed flexion deformity were excluded which might again introduce some selection bias, as patients with a flexion contracture tend to have more severe deformities. Third, the method used for measuring coronal alignment and joint line orientation is subject to measurement error. The method described by Paley et al. was used as it is well defined and reproducible [26]. Our radiology technicians were well trained and had a long-standing experience with the patellar orientation method. Nevertheless, we were well aware of the rotational errors that might be present in the case of patellar malalignment [9].

Our study clearly showed a statistically significant different JL orientation in the different coronal alignment groups (valgus knees vs. neutral knees vs. varus knees). The majority of the OA knees (76%, varus + valgus knees) were found to have a JL orientation that was significantly different from the 3° varus on the tibia and 3° valgus on the femur. The typical varus knee was found to have a neutral femoral JL and a varus inclination of the tibial JL (fig 2). The typical valgus knee was defined by a neutral tibial JL with a valgus femoral JL (fig 3). And the typical neutral knee was found to have a slight varus on the tibia and a slight valgus on the femur (fig 4).



**Fig 5:** Scatter plot of the femoral joint line angle (FJLA) against the hip-knee-ankle angle (HKA). A linear correlation with a  $R^2 = 0.42548$  is observed.



**Fig 6:** Scatter plot of the tibial joint line angle (TJLA) against the hip-knee-ankle angle (HKA). A linear correlation with a  $R^2 = 0.49951$  is observed.

Moreover, JL orientation of the femur and tibia were linearly correlated with the HKA angle (fig 5 and 6). The joint line orientation of femur and tibia should therefore not be considered as dichotomous but as continuous variables. It was calculated that for every degree increase in HKA angle from valgus to varus, a  $-0.4^\circ$  change in tibial joint line and a  $+0.3^\circ$  change in femoral joint line was observed.

A major difference between normal and OA knees was found in the HKA angle (table 3). There was a significant increase in the coronal alignment deformity with progression of the OA process. The difference in HKA angle averaged  $3.7^\circ$  in normal vs. OA valgus knees and  $4.4^\circ$  in normal vs OA varus knees (table 3). This increase in deformity could not be found attributed to changes in the femoral and tibial joint but was almost exclusively the consequence of an increase of the JLCA (table 3). This angle averages  $0.5^\circ$  in the normal knee. This means that the femoral and tibial JL are near parallel (fig 1). It was found to be  $4.6^\circ$  in varus and  $-2.3^\circ$  in valgus OA knees. The major contribution to the increase of the coronal alignment deformity in varus and valgus knees when progressing from normal to OA was made by the JLCA (84% in valgus knees, 93% in varus knees) (fig 2 and 3). This increase in JLCA is the result of cartilage loss on the medial or lateral side, which causes opening up of this angle on the medial or lateral side. Also a varus or valgus thrust with joint space opening will add to the JLCA.

These findings have important implications towards the understanding of the effect of a mechanically aligned TKA on the soft tissue envelope around the knee. In varus knees for instance, the varus HKA angle of  $8.7^\circ$  was on average the result of a JLCA of  $4.6^\circ$  and a varus tibial JL of  $4.9^\circ$  (fig 2). When doing a TKA, correcting for the cartilage wear only will reduce this JLCA to  $0^\circ$  and thus correct the alignment to its pre-diseased state (= undercorrection). No ligament releases would be required. However, to obtain a neutrally aligned limb, a correction of the original JL orientation is required. On the tibial side, the correction is done by resecting the proximal tibia perpendicular to the mechanical axis of the tibia and adding more metal and polyethylene on the medial proximal tibia than the bone that was removed (fig 2). The result will be a corrected limb alignment with a tight medial compartment. As a result, a release of the MCL would therefore be required in many cases. Cutting the proximal tibia in varus could prevent this tibial overstuffing of the medial compartment and no release would be required. But on the other hand, this would result in an overall limb alignment and tibial component in slight varus, which might be detrimental for implant survival. As the femur is already neutrally aligned, no changes would be induced on the femoral side by the femoral component (fig 2).

In valgus knees, the major deformity is located on the femoral side (FJLA =  $-4.8^\circ$ ) (fig 3). The tibial JL is already neutral. Alignment correction in a valgus knee would be achieved by resecting the distal femoral surface perpendicular to the mechanical axis of the femur. This would result in an underresection of the lateral distal femoral surface compared to the medial side. Adding more metal on this distal lateral femoral surface than the bone that was removed would correct the coronal deformity (fig 4). At the same time, this might induce tightness on the lateral side with the need for a

postero-lateral release in many cases. Moreover, this distalised lateral femoral joint line could induce problems with patellar tracking which might also require a release of the lateral retinaculum.

In neutrally aligned OA knees, no alignment correction is needed, as the limb is already neutral. Correction for cartilage loss during TKA should be sufficient to restore the pre-diseased state. A slight varus cut on the proximal tibia together with a slight valgus cut of the distal femur will restore both the pre-diseases limb alignment and JL orientation. Nevertheless, most surgeons will favour a perpendicular cut on the proximal tibia and femur. This will result in a slightly distalised lateral femoral joint line and slight build-up on the medial proximal tibia (fig 5). Both might require a release to correct for ligament tightness.

Another important finding of this study was that in our series the JL orientation in varus and valgus knees showed no significant differences between the normal and the OA knee. This means that in the majority of the OA patients treated with TKA at our service, the bone surface geometry shows almost no differences with the pre-diseased state. The increase in HKA angle in the OA knee is mainly the consequence of cartilage loss in one compartment and sometimes joint space opening on the contralateral side. These findings are consistent with the work of Nam et al. showing that the bone loss on the femoral side is minimal (< 1mm) in 99.5% in patients with Kellgren-Lawrence grade 3 and 4 OA scheduled for TKA [25]. These finding have important implications towards knee replacement surgery. As the bony joint surface shows no changes in most of our OA patient, the question whether we as surgeons should change that surface anatomy, can be raised. Making changes to that bony anatomy will very likely induce changes in strain in the soft tissue envelope around the knee (fig 2 and 3) [17, 19, 21]. Those changes might require a release of the ligaments to obtain a balanced knee again. It was already shown that slight undercorrection after TKA in varus knees is not be as harmful for implant survival as previously thought [4, 13, 23, 29, 30] and might in fact result in a better clinical outcome [31]. The same might be true for a valgus knee. We recently showed that modern instrumentation techniques are already associated with a bias towards undercorrection of the deformity [20].

The concept of restoring the patient's original joint line orientation and thereby, as a consequence, reproducing his natural alignment rather than a neutral mechanical alignment was recently popularised as 'kinematic alignment' [15]. In fact, 'anatomic JL reconstruction' might be a more suitable term, as this is the primary target of the procedure: the restoration of the joint level at its original level. An anatomic reconstruction of the joint surface might indeed reproduce more natural kinematics too, but rather as a consequence then as a primary target. From a functional point of view, kinematically aligned TKA's seem to do very well [14]. A recent level I prospective randomised

trial confirmed these findings, showing a superior functional outcome over the 'classic' mechanically aligned TKA at 2 years postoperatively [11]. Still, questions on the longevity of an implant that is slightly undercorrected persist and more long-term data are required to confirm its safety. The merit of kinematic alignment is that it brought back the importance of joint line orientation to our attention. As a wide variation of JL orientation can be observed in the population with distinct differences between the valgus, neutral and varus knee (table 2), a 'one size fits all' approach in TKA with a perpendicular JL for all patients might not be sufficient. The high number of dissatisfied patients after TKA might be the proof of this [2, 5, 12]. An individualised approach, taking into account the patients original JL orientation and aiming at anatomic JL reconstruction could improve patients' function. From our data, we've shown that the JL in the OA knee can serve as a reliable reference to do so.

## CONCLUSION

The orientation of the joint line was not altered by the OA process in varus and valgus knees. The increase in HKA angle of OA knees was solely the consequence of wear and joint space opening. Bone loss was minimal. Therefore, the joint line of the OA knee is a reliable landmark for anatomic joint line reconstruction in TKA.

## REFERENCES

1. Ahlbäck S. Osteoarthritis of the knee. A radiographic investigation. *Acta Radiol. Diagn. (Stockh)*. 1968;Suppl 277:7–72.
2. Baker PN, van der Meulen JH, Lewsey J, Gregg PJ. The role of pain and function in determining patient satisfaction after total knee replacement. Data from the National Joint Registry for England and Wales. *J. Bone Joint Surg. Br.* 2007;89:893–900.
3. Bellemans J, Colyn W, Vandenneucker H, Victor J. The Chitranjan Ranawat award: is neutral mechanical alignment normal for all patients? The concept of constitutional varus. *Clin. Orthop. Relat. Res.* 2012;470:45–53.
4. Bonner TJ, Eardley WGP, Patterson P, Gregg PJ. The effect of post-operative mechanical axis alignment on the survival of primary total knee replacements after a follow-up of 15 years. *J. Bone Joint Surg. Br.* 2011;93:1217–22.
5. Bourne RB, Chesworth BM, Davis AM, Mahomed NN, Charron KDJ. Patient satisfaction after total knee arthroplasty: who is satisfied and who is not? *Clin. Orthop. Relat. Res.* 2010;468:57–63.
6. Chao EY, Neluhani E V, Hsu RW, Paley D. Biomechanics of malalignment. *Orthop. Clin. North Am.* 1994;25:379–86.
7. Cooke TD, Li J, Scudamore RA. Radiographic assessment of bony contributions to knee deformity. *Orthop. Clin. North Am.* 1994;25:387–93.
8. Cooke TD, Pichora D, Siu D, Scudamore RA, Bryant JT. Surgical implications of varus deformity of the knee with obliquity of joint surfaces. *J. Bone Joint Surg. Br.* 1989;71:560–565.
9. Cooke TD V, Sled E a. Optimizing limb position for measuring knee anatomical axis alignment from standing knee radiographs. *J. Rheumatol.* 2009;36:472–7.

10. Cooke TD V, Sled EA, Scudamore RA. Frontal plane knee alignment: a call for standardized measurement. *J. Rheumatol.* 2007;34:1796–801.
11. Dossett HG, Estrada N a, Swartz GJ, LeFevre GW, Kwasman BG. A randomised controlled trial of kinematically and mechanically aligned total knee replacements: Two-year clinical results. *Bone Joint J.* 2014;96-B:907–13.
12. Dunbar MJ, Richardson G, Robertsson O. I can't get no satisfaction after my total knee replacement: rhymes and reasons. *Bone Joint J.* 2013;95-B:148–52.
13. Fang DM, Ritter MA, Davis KE. Coronal alignment in total knee arthroplasty: just how important is it? *J. Arthroplasty.* 2009;24:39–43.
14. Howell SM, Howell SJ, Kuznik KT, Cohen J, Hull ML. Does a kinematically aligned total knee arthroplasty restore function without failure regardless of alignment category? *Clin. Orthop. Relat. Res.* 2013;471:1000–7.
15. Howell SM, Kuznik K, Hull ML, Siston R a. Results of an Initial Experience with Custom-Fit Positioning Total Knee Arthroplasty in a Series of 48 Patients. *Orthopedics.* 2008;31:857–863.
16. Hsu RW, Himeno S, Coventry MB, Chao EY. Normal axial alignment of the lower extremity and load-bearing distribution at the knee. *Clin. Orthop. Relat. Res.* 1990;255:215–27.
17. Luyckx L, Luyckx T, Bellemans J, Victor J. Iliotibial band traction syndrome in guided motion TKA. A new clinical entity after TKA. *Acta Orthop. Belg.* 2010;76:507–12.
18. Luyckx T, Beckers L, Colyn W, Vandenuecker H, Bellemans J. The adductor ratio: a new tool for joint line reconstruction in revision TKA. *Knee Surg. Sports Traumatol. Arthrosc.* 2014.
19. Luyckx T, Didden K, Vandenuecker H, Labey L, Innocenti B, Bellemans J. Is there a biomechanical explanation for anterior knee pain in patients with patella alta?: influence of patellar height on patellofemoral contact force, contact area and contact pressure. *J. Bone Joint Surg. Br.* 2009;91:344–50.
20. Luyckx T, Vanhoorebeeck F, Bellemans J. Should we aim at undercorrection when doing a total knee arthroplasty? *Knee Surg. Sports Traumatol. Arthrosc.* 2014.
21. Luyckx T, Verstraete M, De Roo K, Dewaele W, Victor J, Bellemans J. The Effect of Single Radius TKA Implantation and Joint Line Proximalisation on the Strain Pattern in the sMCL of the Knee. *Bone Jt. J. Orthop. Proc. Suppl.* 2013;95:401.
22. Luyckx T, Zambianchi F, Catani F, Bellemans J, Victor J. Coronal alignment is a predictor of the rotational geometry of the distal femur in the osteo-arthritic knee. *Knee Surg. Sports Traumatol. Arthrosc.* 2013;21:2331–7.
23. Magnussen RA, Weppe F, Demey G, Servien E, Lustig S. Residual varus alignment does not compromise results of TKAs in patients with preoperative varus. *Clin. Orthop. Relat. Res.* 2011;469:3443–50.
24. Moreland JR, Bassett LW, Hanker GJ, Morelad JR, Bassett LW HG. Radiographic analysis of the axial alignment of the lower extremity. *J. Bone Joint Surg. Am.* 1987;69:745–9.
25. Nam D, Lin KM, Howell SM, Hull ML. Femoral bone and cartilage wear is predictable at 0° and 90° in the osteoarthritic knee treated with total knee arthroplasty. *Knee Surg. Sports Traumatol. Arthrosc.* 2014.
26. Paley D, Herzenberg JE, Tetsworth K, McKie J, Bhave A. Deformity planning for frontal and sagittal plane corrective osteotomies. *Orthop. Clin. North Am.* 1994;25:425–65.
27. Paley D. *Principles of Deformity Correction.* Berlin, Heidelberg: Springer Berlin Heidelberg; 2002:19–30.
28. Paley D. *Principles of Deformity Correction.* Berlin, Heidelberg: Springer Berlin Heidelberg; 2002:1–60.
29. Parratte S, Pagnano MW, Trousdale RT, Berry DJ. Effect of postoperative mechanical axis alignment on the fifteen-year survival of modern, cemented total knee replacements. *J. Bone Joint Surg. Am.* 2010;92:2143–9.
30. Ritter MA, Davis KE, Meding JB, Pierson JL, Berend ME, Malinzak RA. The effect of alignment and BMI on failure of total knee replacement. *J. Bone Joint Surg. Am.* 2011;93:1588–96.
31. Vanlommel L, Vanlommel J, Claes S, Bellemans J. Slight undercorrection following total knee arthroplasty results in superior clinical outcomes in varus knees. *Knee Surg. Sports Traumatol. Arthrosc.* 2013;21:2325–30.
32. Victor J, Wong P, Witvrouw E, Sloten J Vander, Bellemans J. How isometric are the medial patellofemoral, superficial medial collateral, and lateral collateral ligaments of the knee? *Am. J. Sports Med.* 2009;37:2028–36.



33. Victor JMK, Bassens D, Bellemans J, Gürsu S, Dhollander AAM, Verdonk PCM. Constitutional varus does not affect joint line orientation in the coronal plane. *Clin. Orthop. Relat. Res.* 2014;472:98–104.
34. Colebatcha AN, Hartb DJ, Zhaib G, Williamsb FM, Spectorb TD, Ardena NK. Effective measurement of knee alignment using AP knee radiographs. *Knee* 2009;16(1):42–45.
35. Sabharwal S, Zhao C EM. Lower Limb Alignment in Children: Reference Values Based on a Full-Length Standing Radiograph. *J Pediatr Orthop* 2008;28(7):740–746.
36. Sled EA, Cooke D, Sheehy L, Lam M, Costigan P, Nevitt M, et al. 329 RELIABILITY OF LOWER LIMB FRONTAL PLANE ALIGNMENT MEASURES OBTAINED WITH THE USE OF A COMPUTER PROGRAM AND ELECTRONIC TOOLS. *Osteoarthr Cartil* 2007;15(1cc):C184.

## 2.2 THE TIBIO-FEMORAL JOINT LINE IN THE AXIAL PLANE.

**T Luyckx, F Zambianchi, F Catani, J Bellemans, J Victor.**

Coronal alignment is a predictor of the rotational geometry of the distal femur in the osteo-arthritic knee.

*Knee Surg Sports Traumatol Arthrosc* 2013;21(10):2331-7.

### ABSTRACT

#### **Purpose**

There is a lot of inter-individual variation in the rotational anatomy of the distal femur. This study was set up to define the rotational anatomy of the distal femur in the osteo-arthritic knee and to investigate its relationship with the overall coronal alignment and gender.

#### **Methods**

CT-scans of 231 patients with end stage knee osteo-arthritis prior to TKA surgery were obtained. This represents the biggest series published on rotational geometry of the distal femur in literature so far.

#### **Results**

The posterior condylar line (PCL) was on average  $1.58^\circ$  (SD 1.92) internally rotated relative to the surgical transepicondylar axis (sTEA). The perpendicular to trochlear anteroposterior axis ( $\perp$ TRAx) was on average  $4.76^\circ$  (SD 3.34 $^\circ$ ) externally rotated relative to the sTEA. The relationship between the PCL and the sTEA was statistically different in the different coronal alignment groups ( $p < 0.001$ ):  $0.98^\circ$  (SD 1.77 $^\circ$ ) in varus knees,  $2.14^\circ$  (SD 1.84 $^\circ$ ) in neutral knees and  $2.63^\circ$  (SD 1.83 $^\circ$ ) in valgus knees. The same was true for the  $\perp$ TRAx in these 3 groups ( $p < 0.02$ ).

There was a clear linear relationship between the overall coronal alignment and the rotational geometry of the distal femur. For every  $1^\circ$  in coronal alignment increment from varus to valgus, there is a  $0.12^\circ$  increment in posterior condylar angle (PCL vs sTEA).

#### **Conclusion**

The PCL was on average  $1.6^\circ$  internally rotated relative to the sTEA in the osteo-arthritic knee. The relationship between the PCL and the sTEA was statistically different in the different coronal alignment groups.

#### **Level of evidence**

Level III

## INTRODUCTION

Correct rotational alignment of the femoral component is crucial for successful outcome after TKA. Femoral component rotation will affect flexion stability, tibiofemoral and patellofemoral kinematics and alignment in flexion [2,5,10,14,20].

The rotational alignment of the femoral component can be obtained by different techniques. Measured resection is one of these techniques. It uses surface derived reference axis of the distal femur to guide the resection of the anterior and posterior femur. Several different reference axes have been introduced from which the posterior condylar line (PCL) [12,16], the surgical transepicondylar axis (sTEA) [4,5,9], the anatomical transepicondylar axis (aTEA) [22,28] and the trochlear anteroposterior axis (TRAx) [3,26] are the most popular ones.

A recent review of literature has shown that in the native knee, the PCL is on average 3° internally rotated relative to sTEA and 5° internally rotated relative to the aTEA [24]. However, there is a lot of inter-individual variation in these values. This has led some authors to conclude that bony landmarks are unreliable in determining optimal rotational position of the femoral component [7].

The aim of this study was to define the rotational anatomy of the distal femur in the osteo-arthritic knee and investigate its relationship with gender and coronal alignment. It was hypothesized that there is a relationship between the coronal and rotational alignment of the femur in the osteo-arthritic knee.

## MATERIALS AND METHODS

Two hundred fifty four knee CT-scan (taken on 251 consecutive patients undergoing TKA) performed at the orthopaedic department of AZ Sint-Lucas Hospital, Bruges, Belgium, from December 2008 till September 2010 were retrospectively selected. These CT-scans were taken as part of a standard pre-operative protocol in patients with end-stage osteo-arthritis scheduled for TKA. Patients with rheumatoid arthritis or post-traumatic arthritis were excluded. Two hundred and thirty-one CT-scans were eventually withheld for further studying. The average age of the patients was 68.8 years (SD 8.9). Eighty patients were males, 151 were females. The left knee was involved in 116 cases, the right knee in the remaining 115 cases.

The CT scan used was a Philips Brilliance 16 slice CT with a collimation of 0.75. All CT-scans of the knee were performed perpendicular to the long axis of the lower leg with a slice thickness of 1 mm. Reconstructions of the axial plane were made in the bone window with a 1/1 ratio without overlap. All measurements were performed with the Fujifilm's Picture Archiving and Communication System Software.

On the A/P scout image of the CT scan, the mechanical tibiofemoral angle [mTFA] (angle between the femoral mechanical axis and the tibial mechanical axis) and the femoral anatomical angle (angle between the femoral mechanical axis and the femoral anatomical axis) were measured. The patients were subdivided into three categories, based on the mTFA. Varus knees had  $mTFA \leq 177$ , neutrally aligned knees have  $177^\circ < mTFA < 183^\circ$  and valgus knees have  $mTFA \geq 183^\circ$ . Each class was subdivided according to gender in order to evaluate the variability of the femoral rotational anatomy in relation to the gender of the patient.

The rotational reference axes were defined as follows: sTEA: the line connecting the tip of the lateral epicondyle with the lowest point of the medial sulcus (a little proximal and posterior to the medial epicondyle as described by LaPrade et al [15]); aTEA: the line connecting the tip of the medial and the lateral epicondyles of the femur; PCL: the tangent passing through the most posterior part of the medial and lateral femoral condyles. The trochlear anteroposterior axis (TRAx) connects the deepest point of the trochlear groove to the top of the femoral notch with the femur viewed along its mechanical axis. The adequate slice thickness of the CT-scan measurements, allowed us to visualize the medial sulcus in all cases. The following angles were defined, all relative to the sTEA as the reference: aTEA vs. sTEA (Fig. 1b); Posterior condylar angle (PCA) = PCL vs. sTEA (Fig. 1c); TRAx vs. sTEA (Fig. 1d). External rotation of the first reference axis relative to the second one, was denoted as a positive value.

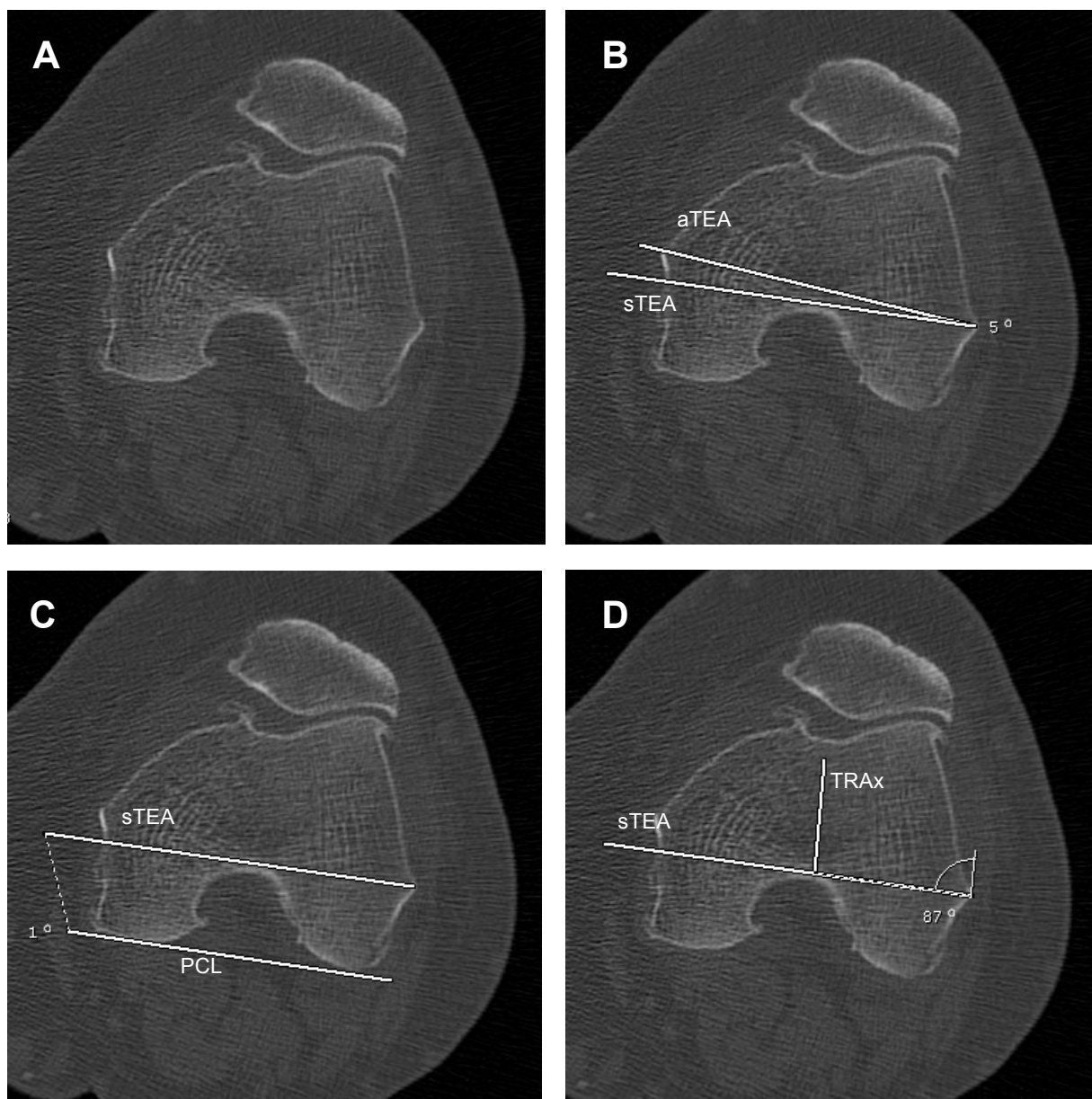
All measurements were performed three times by the same observer (FZ). The average Intra-class Correlation Coefficient (ICC) was 0.86 for the rotational measurements and 0.99 for the coronal alignment of the lower limb.

### *Statistical Analysis*

A multivariate analysis (ANOVA) was performed to compare the average values of the angles, in relation to the coronal deformity of the knee (varus, neutral, valgus) and the gender of the patient.

In order to evaluate the correlation of the femoral rotational values with the coronal deformity of the knee, a linear regression test was performed. For every angle the  $\beta$  value (slope of the line representing the correlation), its 95% confidence interval, the p coefficient and the  $R^2$  were reported

(sTEA vs aTEA: 0.005, -0.009 to 0.198, 0.483; sTEA vs. PCL: 0.121, 0.084 to 0.157, <0.001, 0.1584; sTEA vs.  $\perp$ TRAx: -0.122, -0.189 to -0.055, <0.001, 0.0538) All analysis have been performed using the statistical package STATA<sup>®</sup> 11.0 (StataCorp LP, Texas – USA). P-values were two-sided and considered significant if smaller than 0.05.



**Figure 1:** Rotational measurements as performed on the axial images of the CT-scan. A: native knee; B: sTEA vs. aTEA; C: sTEA vs. PCL; d: sTEA vs. TRAx. sTEA = surgical transepicondylar axis; aTEA = anatomical transepicondylar axis; PCL = posterior condylar line; TRAx = trochlear antero-posterior axis.

**Table 1:**

Overview of the coronal and rotational alignment parameters according to the different coronal alignment categories. A positive value indicates external rotation of the relation's first reference axis relative to the second one. (\* indicates a statistical significant difference; n.s = non-significant).

		mTFA (°)	aTEA vs sTEA (°)	sTEA vs PCL (°)	└TRAx vs sTEA (°)
VARUS n = 130	Mean ± S.D.	172.5 ± 3.6	4.7 ± 0.7	<b>1.0 ± 1.8 *</b>	<b>5.2 ± 3.4 *</b>
	Min.	158.0	3	-2	-4
	Max.	177.0	6	6	12
NEUTRAL n = 58	Mean ± S.D.	179.6 ± 1.4	4.6 ± 0.7	<b>2.1 ± 1.8 *</b>	<b>4.7 ± 3.4 *</b>
	Min.	178.0	3	-6	-3
	Max.	182.0	6	5	15
VALGUS n = 43	Mean ± S.D.	187.5 ± 4.0	4.8 ± 0.7	<b>2.6 ± 1.8 *</b>	<b>3.5 ± 2.8 *</b>
	Min.	183.0	4	-2	-3
	Max.	201.0	7	7	8
TOTAL n = 231	Mean ± S.D.	177.1 ± 6.4	4.7 ± 0.7	1.6 ± 1.9	4.76 ± 3.3
	Min.	158.0	3	-6	-4
	Max.	201.0	7	7	15
p			n.s.	< 0.001	0.016

mTFA (°)	aTEA vs sTEA (°)	sTEA vs PCL (°)	TRAx vs sTEA (°)
<169	4.7	<b>-0.6</b>	7.9
169-171	4.7	<b>0.7</b>	4.1
172-174	4.6	<b>1.1</b>	5.7
175-177	4.9	<b>1.4</b>	4.6
178-182	4.6	<b>2.1</b>	4.7
183-185	4.9	<b>2.8</b>	4.2
186-188	4.9	<b>2.7</b>	4.2
189-191	4.9	<b>2.0</b>	3.9
>191	4.8	<b>4.0</b>	3.6

**Table 2:** The mean of the rotational parameters represented for the different coronal alignment categories with 3° increments. A positive value indicates external rotation of the first reference axis relative to the second one.

## RESULTS

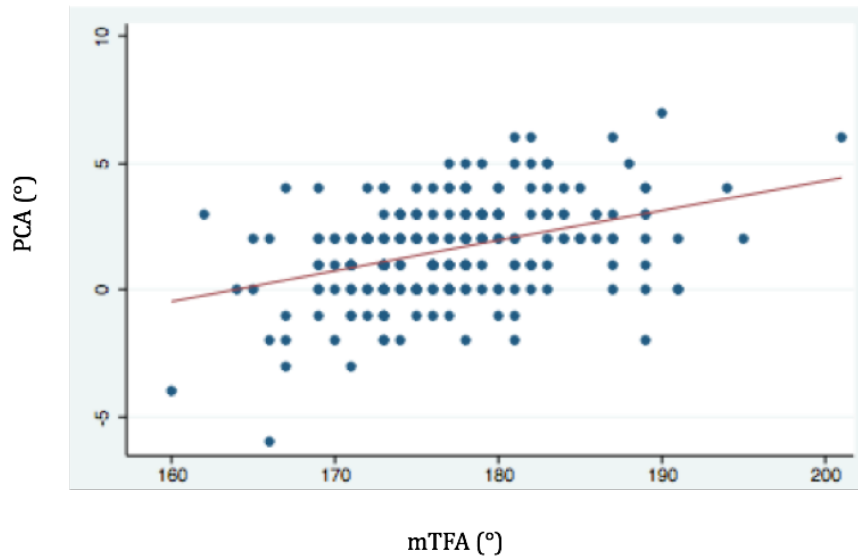
The aTEA was on average 4.7° (SD 0.7°) externally rotated relative to sTEA. The perpendicular to TRAx ( $\perp$ TRAx) was on average 4.8° (SD 3.3°) externally rotated relative to the sTEA and the PCL was on average 1.6° (SD 1.9) internally rotated relative to the sTEA.

The results from the rotational anatomy according to three different coronal alignment categories (varus/neutral/valgus) are presented in table 1. The angle between sTEA and aTEA was not statistically significant different in all three categories of coronal deformity. For the angle between the sTEA and the PCL, we observed statistically significant differences between the different coronal alignment groups ( $p < 0.001$ ): 1.0° (SD 1.8°) for varus knees, 2.1° (SD 1.8°) in neutral knees and 2.6° (SD 1.8°) for valgus knees. Also the angle between sTEA and the  $\perp$ TRAx was statistically different between the 3 groups ( $p < 0.02$ ), although this difference was less strong (table 1). The mean rotational values for the different coronal alignment categories with 3° increments are represented in table 2.

Statistical analysis revealed a linear relationship between the coronal alignment and the rotational anatomy of the distal femur: a 0.1° PCA increment was observed with every 1° increment of coronal deformity from varus to valgus ( $p < 0.001$ ) ( $R = 0.4$ ) (Fig. 2).

No overall statistical different values were observed between males and females (table 3). There were also no significant differences for the aTEA vs. sTEA angle. Men and women had the same PCA in varus knees. Significant gender differences were found in neutral and valgus knees with women having a significant greater PCA. The angle between sTEA and  $\perp$ TRAx didn't differ significantly

between the two genders in varus and neutrally aligned knees. In female valgus knees however this angle was significantly greater when compared to males knees.



**Figure 2:** Scatterplot of the mechanical tibiofemoral angle ( $mTFA^\circ$ ) versus the posterior condylar angle (PCA). The red line indicates the linear correlation between the two variables ( $R=0.4$ ,  $p<0.001$ ).

		aTEA vs sTEA ( $^\circ$ )		sTEA vs PCL ( $^\circ$ )		$\perp$ TRAx vs sTEA ( $^\circ$ )	
		M	F	M	F	M	F
VARUS $M = 54 - F = 76$	Mean	4.8	4.7	1.1	0.9	5.5	5.0
	S.D.	0.7	0.7	1.9	1.7	3.2	3.6
NEUTRAL $M = 15 - F = 43$	Mean	4.5	4.7	<b>1.9*</b>	<b>2.2*</b>	4.8	4.7
	S.D.	0.8	0.7	1.8	1.9	3.4	3.4
VALGUS $M = 11 - F = 32$	Mean	4.6	4.9	<b>1.7*</b>	<b>2.9*</b>	<b>2.7*</b>	<b>3.8*</b>
	S.D.	0.7	0.8	1.0	2.0	3.1	2.6
TOTAL $M = 80 - F = 151$	Mean	4.6	4.7	1.3	1.7	5.0	4.6
	S.D.	0.7	0.7	1.8	2.0	3.3	3.6

**Table 3:** Rotational parameters according to gender and coronal deformity. A positive value indicates external rotation of the first reference axis relative to the second one. \* indicates a statistical significant difference



## DISCUSSION

This study was set up to identify of the rotational anatomy of the distal femur and some of its determinants. It represents the biggest series published in literature so far.

The mean PCA was found to be on average  $1.6^\circ$  (SD 1.9) in the osteo-arthritic knee (table 1). This value is different from previous studies in healthy knees that showed a mean PCA of  $3^\circ$  [4,18]. It is also somewhat different from the findings in previous smaller series in the osteo-arthritic knee [2,8,18,21,22,27]. It is our believe that, apart from the coronal alignment, the degree of osteo-arthritis and more specific the involvement of the posterior condyles in the osteo-arthritic process is also an important determinant of the rotational geometry [23]. This might explain part of observed the variation. The degree of osteo-arthritis was not studied in previous reports nor our report.

The rotational anatomy of the distal femur is the reference frame to determine the rotation of the femoral component in TKA when using a measured resection technique. Also the newer patient specific cutting blocks are in fact an extension of this technique and do rely on the bony landmarks. The posterior condylar line (PCL) [12,16], the surgical transepicondylar axis (sTEA) [4,5,9], the anatomical transepicondylar axis (aTEA) [22,28] and the trochlear anteroposterior axis (TRAx) [3,26] are the most popular axis constituting the rotational reference frame. The primary goal in axial plane alignment is to align the femoral component with the TEA [4,6,25]. However, the aTEA and the sTEA are axis that are difficult to localize intra-operative [13]. As a result, inter and intra-observer variability for locating these axes is very high. Therefore, secondary reference axes have been validated. The PCL and the TRAx are such axis. The PCL is easy to locate intra-operative. However, its relationship with the sTEA and the aTEA is not constant and high inter-individual variation has been reported. One can state that the PCL is on average  $3^\circ$  internally rotated in relationship to the sTEA [24]. Most instrumentation systems will therefore advocate a standard  $3^\circ$  of external rotation relative to the PCL [16]. As there is quite a lot of variation in this relationship, using this reference axis will not result in a balanced flexion gap in all patients [8,16]. This has led some authors to conclude that bony landmarks are unreliable in determining optimal rotational position of the femoral component [7]. However, we do not agree with this statement.

At our institution (AZ Sint-Lucas Hospital, Bruges, Belgium), all patients undergo a pre-operative CT-scanning of the distal femur as part of a standard preoperative TKA protocol. This CT-scan is used to determine the native PCA of the individual patient. Using a PCL referencing technique, the PCA value is used intra-operatively to compensate for an eventual deviation. When a  $x^\circ$  internal rotation of PCL relative to the sTEA of the native femur is measured on pre-operative CT-scan, we externally rotate

our cutting block by an additional  $x-3^\circ$  (so  $x^\circ$  in total). For instance, when a  $4^\circ$  internal rotation of PCL relative to the sTEA of the native femur is measured on pre-operative CT-scan, we would externally rotate our cutting block by an additional  $1^\circ$  (so  $4^\circ$  in total) by placing a shim underneath the lateral condyle in our posterior referenced instrumentation system. The opposite is true for smaller values. This technique was termed 'adapted measured resection'[17]. In this way, the rotational adaptation of the femoral component is tailored to the patient's original anatomy. In practice, this means that for valgus knees, often more of  $3^\circ$  of external rotation is needed (table 2). In varus knee, often less than  $3^\circ$  of external rotation is used (table 2). This resulted in a more consistent rotation of the femoral component with a smaller range and smaller standard deviation than those reported in the literature [17]. The major downside of this technique is the need for a pre-operative CT-scan and thus extra cost and radiation exposure. If one could identify the determinants of the rotational anatomy of the distal femur, the femoral rotation could be accurately predicted on basis of the coronal alignment and without the CT-scan.

It has been known that there is a correlation between the coronal alignment and the rotational geometry of the distal femur. In varus knees a smaller PCA is observed compared to valgus knees [9,16,19,22]. However this relationship was not clearly defined yet. In our series, it was shown that there was a clear linear relationship between the coronal and the rotational geometry of the distal femur. For every  $1^\circ$  in coronal alignment increment from varus to valgus, there is a  $0.1^\circ$  increment of the PCA. These data are consistent with those of Aglietti who also found a linear relationship between the PCA and the coronal alignment [1]. A  $1^\circ$  PCA increment was observed with every  $10^\circ$  increment of coronal deformity from varus to valgus. Taking this relationship in account can significantly increase the accuracy of the femoral component rotational position. We would therefore recommend a pre-operative full-leg standing X-ray in all patients undergoing TKA. Using table 2, the surgeon can predict the rotational geometry of the distal femur and use this information intra-operatively. A pre-operative CT or MRI scan is also very helpful in many cases. It is critical in demonstrating of the patient's actual anatomy, which is in our experience crucial information to be used intra-operatively.

Berger et al reported on the different rotational anatomy between males and females. He observed a PCA of  $3.5^\circ$  in males and  $0.3^\circ$  in females. However, they did not investigate the relationship with coronal alignment. In our series, there is a different rotational anatomy between males and females in the neutral and the valgus knees, but not in varus knees. Moreover the differences are not that big. We therefore believe that most of the previous reported gender differences can be contributed to differences in coronal alignment.

The relationship between the sTEA and the aTEA is a fixed one and does not vary between the different coronal alignment categories. This observation could allow us to calculate the sTEA axis from the anatomical location of the epicondyles during computer navigated TKA.

This study has several limitations. To reduce the radiation dose, the alignment measurements were made on the scouting view of the CT-scan and no additional standing full-leg radiographs were made. This might cause an underestimation of the coronal deformity. Nevertheless our data are very consistent with those published by Aglietti et al [1] who did use standing radiographs. Secondly, we did not take into account the degree of osteo-arthritis and more specific the involvement of the posterior condyles in the process as this was difficult to quantify. Nevertheless this involvement has its impact on the rotational measurements. Thirdly, rotational measurements were made on the 2D axial plane images of the CT-scan. However the sTEA is a 3D based structure. The sulcus on the medial side and the lateral epicondyle lie almost never in the same axial plane. An approximation of its position was made. To increase the accuracy, 3D measurements are necessary [11].

## CONCLUSION

The mean PCA was found to be  $1.6^\circ$  (SD 1.9) in the osteo-arthritic knee. The relationship between the PCL and the sTEA was significantly different in the different coronal alignment groups. A linear relationship was observed between the coronal alignment and the rotational geometry of the distal femur. Taking this relationship into account could significantly increase the accuracy of the rotational position of the femoral component in TKA.

## REFERENCES

1. Aglietti P, Sensi L, Cuomo P, Ciardullo A (2008) Rotational position of femoral and tibial components in TKA using the femoral transepicondylar axis. *Clin Orthop Relat Res* 466:2751-2755.
2. Akagi M, Matsusue Y, Mata T, Asada Y, Horiguchi M, Iida H, Nakamura T (1999) Effect of rotational alignment on patellar tracking in total knee arthroplasty. *Clin Orthop Relat Res* 366:155-163.
3. Arima J, Whiteside LA, McCarthy DS, White SE (1995) Femoral rotational alignment, based on the anteroposterior axis, in total knee arthroplasty in a valgus knee. A technical note. *J Bone Joint Surg Am* 77:1331-1334.
4. Asano T, Akagi M, Nakamura T (2005) The functional flexion-extension axis of the knee corresponds to the surgical epicondylar axis: in vivo analysis using a biplanar image-matching technique. *J Arthroplasty* 20:1060-1067.

5. Berger RA, Rubash HE, Seel MJ, Thompson WH, Crossett LS (1993) Determining the rotational alignment of the femoral component in total knee arthroplasty using the epicondylar axis. *Clin Orthop Relat Res* 286:40-47.
6. Churchill DL, Incavo SJ, Johnson CC, Beynon BD (1998) The transepicondylar axis approximates the optimal flexion axis of the knee. *Clin Orthop Relat Res* 356:111-118.
7. Dennis DA (2008) Measured resection: an outdated technique in total knee arthroplasty. *Orthopedics* 31:940-944.
8. Fehring TK (2000) Rotational malalignment of the femoral component in total knee arthroplasty. *Clin Orthop Relat Res* 380:72-79.
9. Griffin FM, Insall JN, Scuderi GR (1998) The posterior condylar angle in osteoarthritic knees. *J Arthroplasty* 13:812-815.
10. Hanada H, Whiteside L, Steiger J, Dyer P, Naito M (2007) Bone landmarks are more reliable than tensioned gaps in TKA component alignment. *Clin Orthop Relat Res* 462:137-142.
11. Hirschmann MT, Konala P, Amsler F, Iranpour F, Friederich NF, Cobb JP (2011) The position and orientation of total knee replacement components: a comparison of conventional radiographs, transverse 2D-CT slices and 3D-CT reconstruction. *J Bone Joint Surg Br* 93:629-633.
12. Hungerford DS, Kenna RV (1983) Preliminary experience with a total knee prosthesis with porous coating used without cement. *Clin Orthop Relat Res* 176:95-107.
13. Jenny JY, Boeri C (2004) Low reproducibility of the intra-operative measurement of the transepicondylar axis during total knee replacement. *Acta orthop Scand* 75:74-77.
14. Kim D, Seong SC, Lee MC, Lee S (2012) Comparison of the tibiofemoral rotational alignment after mobile and fixed bearing total knee arthroplasty. *Knee Surg Sports Traumatol Arthrosc* 20:337-345.
15. LaPrade RF, Engebretsen AH, Ly TV, Johansen S, Wentorf FA, Engebretsen L (2007) The anatomy of the medial part of the knee. *J Bone Joint Surg Am* 89:2000-2010.
16. Laskin RS (1995) Flexion space configuration in total knee arthroplasty. *J Arthroplasty* 10:657-660.
17. Luyckx T, Peeters T, Vandenneucker H, Victor J, Bellemans J (2012) Is adapted measured resection superior to gap-balancing in determining femoral component rotation in total knee replacement? *J Bone Joint Surg Br* 94:1271-1276.
18. Matsuda S, Matsuda H, Miyagi T, Sasaki K, Iwamoto Y, Miura H (1998) Femoral condyle geometry in the normal and varus knee. *Clin Orthop Relat Res* 349:183-188.
19. Matsuda S, Miura H, Nagamine R, Mawatari T, Tokunaga M, Nabeyama R, Iwamoto Y (2004) Anatomical analysis of the femoral condyle in normal and osteoarthritic knees. *J Orthop Res* 22:104-109.
20. Merican AM, Ghosh KM, Iranpour F, Deehan DJ, Amis AA (2011) The effect of femoral component rotation on the kinematics of the tibiofemoral and patellofemoral joints after total knee arthroplasty. *Knee Surg Sports Traumatol Arthrosc* 19:1479-1487.
21. Nagamine R, Miura H, Inoue Y, Urabe K, Matsuda S, Okamoto Y, Nishizawa M, Iwamoto Y (1998) Reliability of the anteroposterior axis and the posterior condylar axis for determining rotational alignment of the femoral component in total knee arthroplasty. *J Orthop Sci* 3:194-198.
22. Poilvache PL, Insall JN, Scuderi GR, Font-Rodriguez DE (1996) Rotational landmarks and sizing of the distal femur in total knee arthroplasty. *Clin Orthop Relat Res* 331:35-46.
23. Tashiro Y, Uemura M, Matsuda S, Okazaki K, Kawahara S, Hashizume M, Iwamoto Y (2012) Articular cartilage of the posterior condyle can affect rotational alignment in total knee arthroplasty. *Knee Surg Sports Traumatol Arthrosc* 20:1463-1469.
24. Victor J (2009) Rotational alignment of the distal femur: a literature review. *Orthop Traumatol Surg Res* 95:365-372.
25. Victor J, Van Doninck D, Labey L, Van Glabbeek F, Parizel P, Bellemans J (2009) A common reference frame for describing rotation of the distal femur: a ct-based kinematic study using cadavers. *J Bone Joint Surg Br* 91:683-690.
26. Whiteside L, Arima J (1995) The anteroposterior axis for femoral rotational alignment in valgus total knee arthroplasty. *Clin Orthop Relat Res* 321:168-172.
27. Yoshino N, Takai S, Ohtsuki Y, Hirasawa Y (2001) Computed tomography measurement of the surgical and clinical transepicondylar axis of the distal femur in osteoarthritic knees. *J Arthroplasty* 16:493-497.
28. Yoshioka Y, Siu D, Cooke TD (1987) The anatomy and functional axes of the femur. *J Bone Joint Surg Am* 69:873-880.

# **CHAPTER 3:**

## **THE BIOMECHANICAL EFFECT OF JOINT LINE ELEVATION IN TKA**

---

**3**

# CHAPTER 3: CONTENTS

---

<b>3.1 The effect of elevating the level of the patellofemoral joint line</b>	<b>73</b>
<b>3.2 The effect of joint line elevation on strain in the medial collateral ligament</b>	<b>89</b>
3.2.1 Development of a new method for strain measurement in human tendon tissue.	89
A. <i>VALIDATION OF DIGITAL IMAGE CORRELATION AS TOOL FOR STRAIN ANALYSIS IN HUMAN TENDON TISSUE</i>	89
B. <i>APPLICATION OF DIGITAL IMAGE CORRELATION FOR 3D STRAIN ANALYSIS OF THE SUPERFICIAL MEDIAL COLLATERAL LIGAMENT OF THE KNEE</i>	102
3.2.2 The effect of joint line elevation on strain in the superficial medial collateral ligament	119
<b>3.3 The effect of joint line elevation on coronal plane stability of the knee</b>	<b>131</b>
<b>3.4 Development and validation of a geometrical model of the knee to predict the effect of joint line changes on the coronal plane stability</b>	<b>146</b>

# CHAPTER 3: THE BIOMECHANICAL EFFECT OF JOINT LINE ELEVATION IN TKA

---

## 3.1 THE EFFECT OF ELEVATING THE LEVEL OF THE PATELLOFEMORAL JOINT LINE.

**T Luyckx, K Didden, H Vandenneucker, L Labey, B Innocenti, J Bellemans.**

Is there a biomechanical explanation for anterior knee pain in patients with patella alta?

*J Bone Joint Surg [Br] 2009;91-B:344-50*

### *ABSTRACT*

The purpose of this study was to test the hypothesis that patella alta leads to a less favourable situation in terms of patellofemoral contact force, contact area and contact pressure than the normal patellar position, and thereby gives rise to anterior knee pain.

A dynamic knee simulator system based on the Oxford rig and allowing six degrees of freedom was adapted in order to simulate and record the dynamic loads during a knee squat from 30° to 120° flexion under physiological conditions. Five different configurations were studied, with variable predetermined patellar heights.

The patellofemoral contact force increased with increasing knee flexion until contact occurred between the quadriceps tendon and the femoral trochlea, inducing load sharing. Patella alta caused a delay of this contact until deeper flexion. As a consequence, the maximal patellofemoral contact force and contact pressure increased significantly with increasing patellar height ( $p < 0.01$ ). Patella alta was associated with the highest maximal patellofemoral contact force and contact pressure. When averaged across all flexion angles, a normal patellar position was associated with the lowest contact pressures.

Our results indicate that there is a biomechanical reason for anterior knee pain in patients with patella alta.

*INTRODUCTION*

Anterior knee pain may be present in as many as 30% of physically active individuals [1,2].

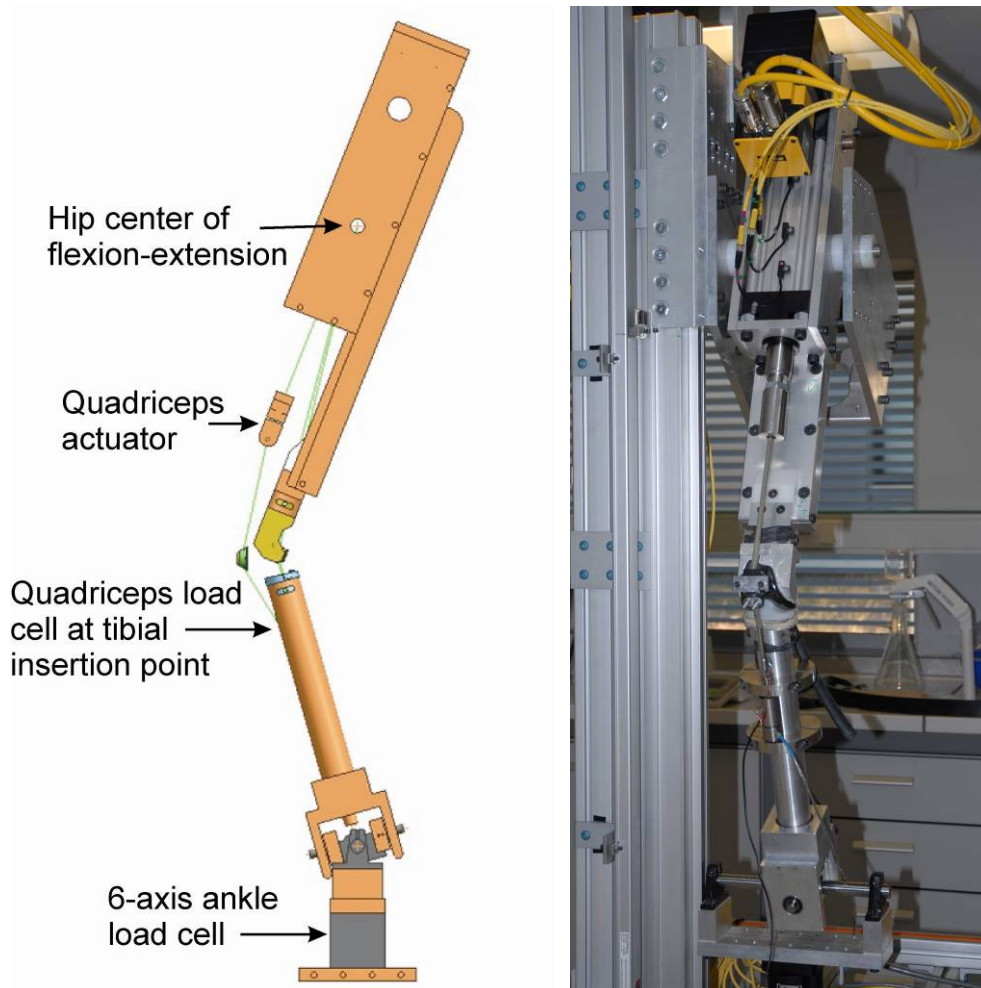
Several factors have been associated with anterior knee pain, including patella alta, [3-5] but the precise mechanism by which this leads to anterior knee pain remains poorly understood.

From a biomechanical point of view, the patellofemoral joint acts as a lever which transmits the force of the quadriceps muscle to the lower leg [6-8]. The patella increases the moment arm of the quadriceps, especially in late extension, facilitating full extension [9]. The patellofemoral mechanism is a type of lever which sacrifices force for displacement. The lever arm is relatively short, as the fulcrum is located further away from the load. The load can therefore be displaced over a much greater distance, but the force that needs to be generated is also greater. In the patellofemoral lever system the patella acts as the fulcrum. It has a number of specific characteristics that from a biomechanical point of view make it extremely well suited for its function. In the normal knee, the maximal patellofemoral contact pressure is reached at about 90° of flexion. The patellofemoral contact area gradually increases with flexion and reaches a maximum at 90° of flexion, thereby reducing the contact stress in deeper flexion. As the knee flexes, the patellar contact point gradually shifts proximally to an area where the cartilage is thicker. Hence, the patellofemoral joint shows maximal contact area and maximal cartilage thickness in the range of movement where the compressive loads are highest. The delicate balance between the maximal contact area, the maximal thickness of the articulating cartilage and the maximal compressive load can easily be disturbed.

Although some studies [10-13] have suggested that persons with patella alta may have altered mechanics of knee extension which predispose them to higher joint reaction forces, the literature does not provide a consensus on the precise effect of patella alta on patellofemoral force, contact area and contact pressure.

The recent availability of validated dynamic knee simulators and advances in the analysis of contact force and contact area have now made such studies possible. We have used a third-generation dynamic Oxford knee simulator under physiological loading conditions during a deep knee squat to study the influence of patellar height on patellofemoral contact force, contact area and contact pressure.

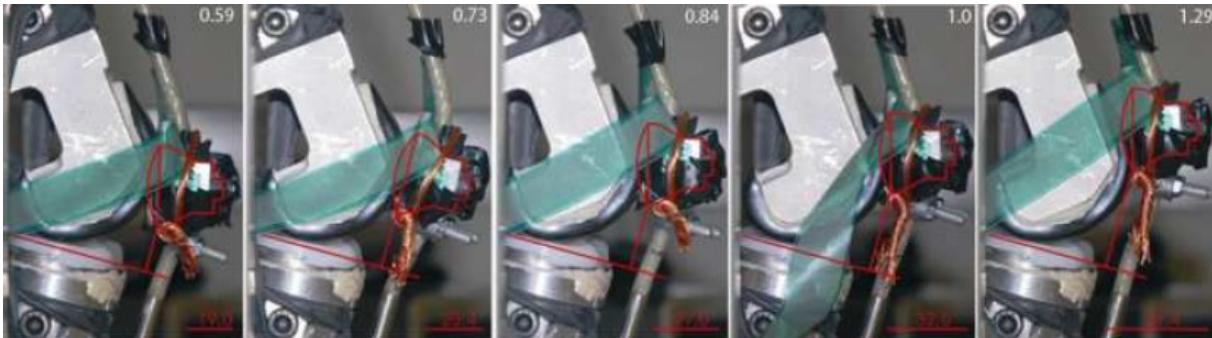




**Figure 1:** Schematic drawing and photograph of the knee simulator used for the experiments.

## *MATERIALS AND METHODS*

A dynamic knee simulator system based on the Oxford rig was adapted for this study (Fig. 1). It consisted of an upper and lower leg mounted on a frame with a hip and ankle assembly. Two actuators controlled the movement, one moving the hip (vertical sliding) and one pulling the quadriceps. The quadriceps actuator was positioned on the upper leg in a way that reproduced its anatomical location with respect to the moment arms around the knee. Sensors placed in line with the actuators were used to record the patellar tendon force, the ankle forces and moments, and the hip height relative to the ankle.



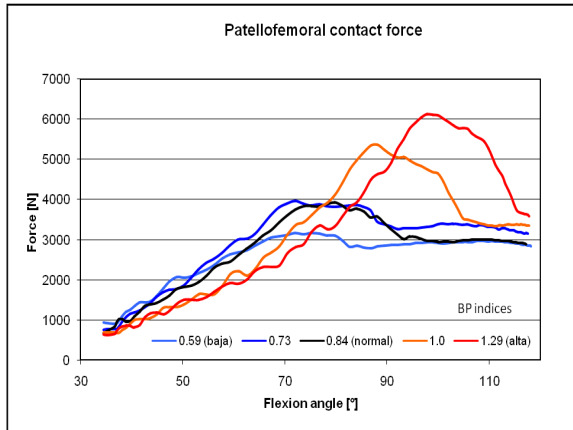
**Figure 2:** Illustration of the different patella positions. Pictures were used to determine the Blackburne-Peel index for each case. The Blackburne peel index is indicated in the right upper corner of each picture.

The knee simulator was designed with 6° of freedom of movement: 2° of freedom for movement in the hip joint (flexion/extension and rotation around the transverse axis) and 4° of freedom for movement in the ankle joint (medial/ lateral translation, flexion/extension, internal/external rotation and abduction/adduction). In this way, the knee was allowed full spatial freedom in order to reproduce its normal kinematics [14].

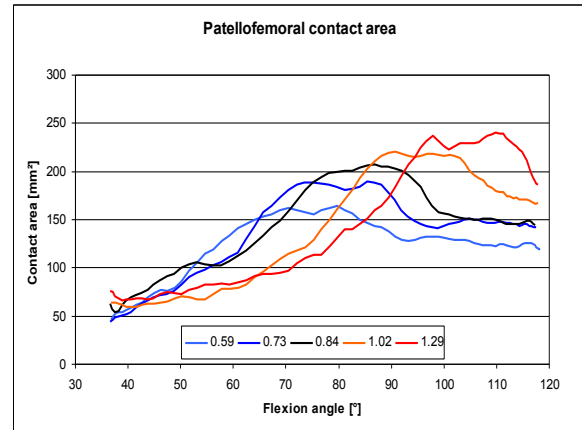
An electromechanical system was designed to simulate and record the dynamic loads during a knee squat between 30° and 120° of flexion under physiological loading conditions, as described below. A real-time data acquisition and closed feedback system (Labview, National Instruments, Austin, Texas) was used to perform a squat with a certain hip velocity, given as a function of time, while simultaneously applying a quadriceps force on the knee to induce a vertical ankle force. Error feedback from the six-axis ankle load cell was used to control the quadriceps actuator.

Custom-made rigid fixtures simulated the tibia and femur, and were covered with the components of a posteriorly stabilised total knee replacement (TKR). A size 5 femoral component was used with a size 4 baseplate, a size 3 to 4, 9 mm thick insert and a 32 mm resurfacing patellar component (Genesis II, Smith & Nephew, Memphis, Tennessee). These intermediate size combinations of implants are currently marketed and used clinically. A 6.4 mm diameter stainless steel cable (Sanlo, Michigan City, Indiana) simulated the patellar and quadriceps tendons.

A K-Scan 4000/9000 psi sensor (Tekscan, South Boston, Massachusetts) was calibrated according to the manufacturer's instructions. One foot of the sensor was fixed to cover the entire articular surface of the patella using custom wire and adhesive fixtures that did not interfere with the patellofemoral interface. The other foot of the sensor was left unattached. A commercial lubricant was applied at the patellofemoral interface between the sensor and the femoral component to reduce shear forces.



**Figure 3:** Experimentally determined patellofemoral contact force for the different patella positions (in terms of Blackburne-Peel index) at 77 pounds target ankle load



**Figure 4:** Experimentally determined patellofemoral contact area for the different patella positions (in terms of Blackburne-Peel index) at 77 pounds target ankle load.

The patellar component was attached to a metal fixture, which could be moved along the steel cable that represented the patellar tendon and fixed at different positions, thereby simulating different patellar heights. The Blackburne-Peel index was used to define patellar height [15-17]. Five different heights were tested: Blackburne-Peel indices of 0.59 (the lowest), 0.73, 0.84 (normal), and 1.0 and 1.29 (patella alta). Lateral photographs were taken in a standardised way at the beginning and end of each experiment, with the knee loaded in 30° of flexion. The Blackburne-Peel index was then measured on these images (fig. 2).

The load and movement input curves used for this experiment simulated a single squat from 30° to 120° of flexion at a constant hip velocity over a 10-second interval and with a constant target ankle load. The results of a squat from 120° to 30° of extension were similar, but are not discussed here.

For all positions of the patella, each squat was repeated twice at 55, 66 and 77 lb target ankle load. In total 30 squats were performed. The quadriceps load, ankle loads and moments, hip position, patellofemoral contact force, contact area and contact pressure were all continuously recorded in a real-time feedback loop.

*Statistical analysis.*

Spearman’s correlation coefficient was used to assess the association between the maximal patellofemoral contact force, the contact area and pressure and the patellar height. Statistical analysis used SPSS statistical software (version 16.0; SPSS Inc., Chicago, Illinois) with a significance level of  $p < 0.01$ .

BP-index	Contact force [N] at						Max
	Min	40°	60°	80°	100°	120°	
0.59	903	1354	2691	3098	2922	2848	3169
0.73	756	1187	3004	3817	3387	3147	3876
0.84	669	1085	2622	3927	2944	2893	3927
1.02	668	1005	2212	4119	4646	3351	5365
1.29	626	813	1906	3330	6101	3592	6129

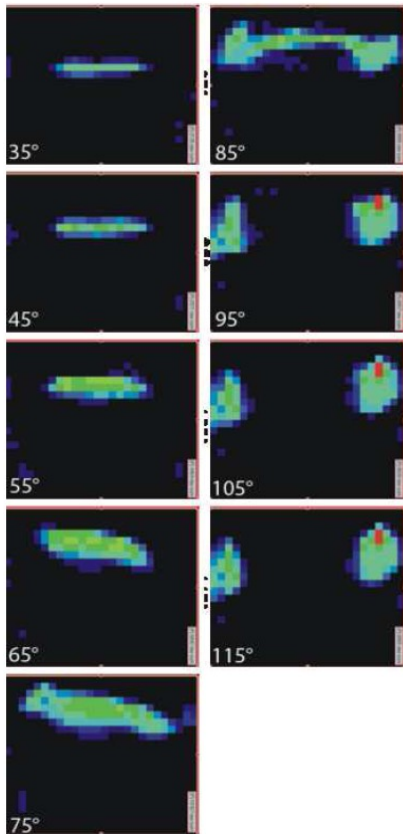
**Table 1:** Contact forces at different flexion angles with minimum contact force and maximum contact force for each patellar position.

## RESULTS

For all positions of the patella, the patellofemoral contact force increased with increasing knee flexion. It reached a maximum followed by a decrease (fig. 3), which coincided with the occurrence of contact between the quadriceps tendon and the femoral trochlea.

In initial flexion (35° to 70°) lower positions of the patella were associated with higher contact forces. Higher positions were associated with a reduction of the patello-femoral contact forces in this range of flexion. At 60°, for example, there was 780 N (41%) less contact force in the highest position of the patella than in the lowest. Patellar alta was associated with the lowest minimal contact force and the lowest patellar position with the highest minimal contact force. The difference between these was as high as 44% (274 N) (Table I).

In deeper flexion (70° to 120°) patella alta was associated with higher contact forces than with the normal patellar height. Lower positions of the patella were associated with lower contact forces in deeper flexion. There was a direct relationship between the maximal contact force and patellar height. The higher the position of the patella, the greater the maximal contact force. Patella alta caused the greatest maximal contact force (Table I). The difference in maximal contact force between the highest and the lowest positions of the patella was 3040 N. The flexion angle at which the maximal contact force occurred also increased with increasing patellar height. Patellar tendon forces measured during the experiment increased with knee flexion until a maximum was reached at 120° of flexion. No significant differences in patellar tendon force were observed between the different patellar heights.



**Figure 5:** Tekscan recordings at selected flexion angles. BP index was 0.84 for this example. The top of the patella is up, bottom is down in each frame. The Flexion angle is indicated in the left lower corner of each frame.

BP-index	Flexion angle [°]
0,59	75
0,73	77
0,84	80
1,02	88
1,29	98

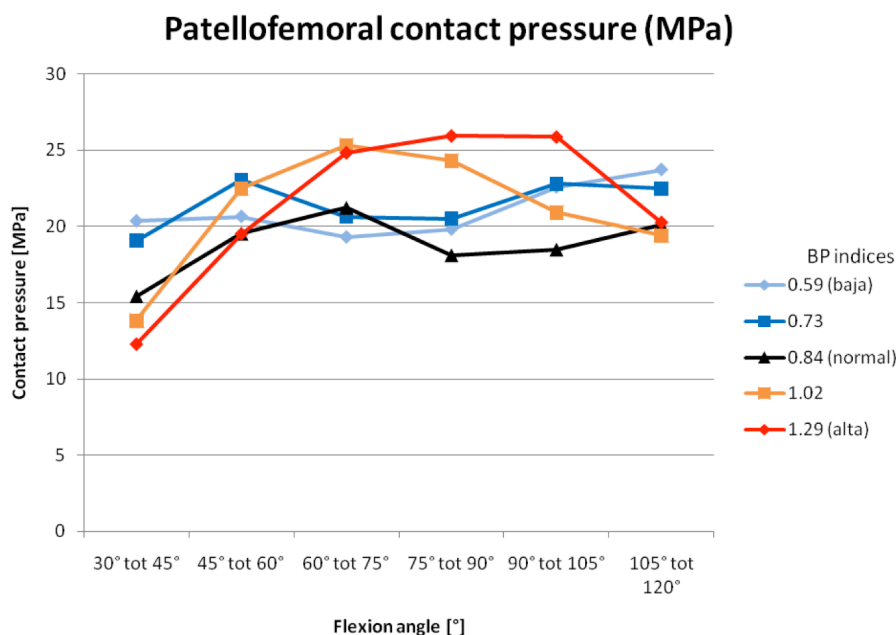
**Table 2:** Flexion angle at which load sharing starts for the different patellar positions

BP-index	Contact area [mm <sup>2</sup> ]		Flexion angle at max [°]
	Min	Max	
0.59	44	168	77
0.73	44	192	84
0.84	48	208	89
1.02	58	223	96
1.29	65	245	110

**Table 3:** Minimum and maximum contact area for each patellar position and the flexion angle at which the maximum contact area is seen.

Total patellofemoral contact area gradually increased with flexion until a maximum was reached, and thereafter decreased (Fig. 4). For the normal patellar height, the contact area reached a maximum at 90° of flexion (Table II). The maximal total contact area was higher and occurred at deeper angles of flexion for patella alta than for lower positions of the patella ( $p < 0.01$ ) (Table II). Patella alta was associated with the highest maximal patellofemoral contact area. The difference between the highest and the lowest maximal contact area was 77 mm<sup>2</sup>. Maximal contact occurred at the transition of patellar support by the trochlea to the femoral condyles.

The Tekscan frames demonstrated a different location of the patellofemoral contact for different heights of the patella in initial flexion (35° to 70°). The lowest position was associated with the most proximal point of patello-femoral contact. A gradual distal shift of the contact point on the patella was observed with increasing patellar height. Patella alta was associated with the most distal contact point in initial flexion. The recordings of the Tekscan frames at Blackburne-Peel index 0.84 are presented in Figure 5.

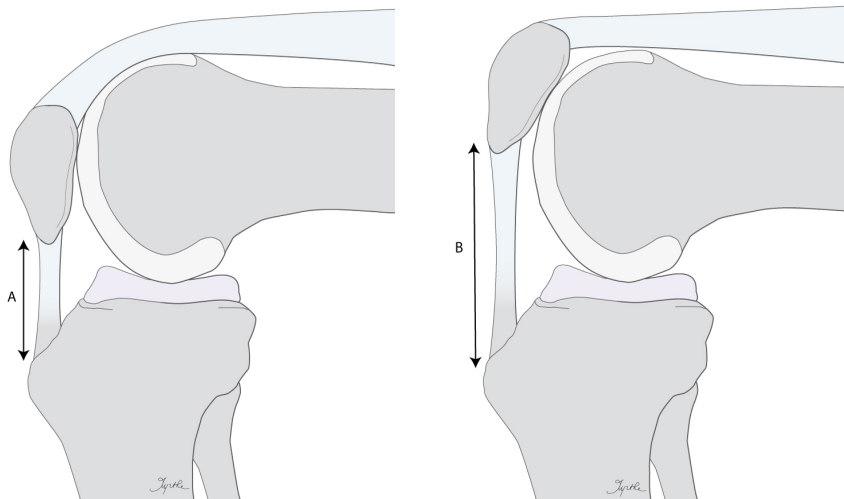


**Figure 6:** Experimentally determined average patellofemoral contact pressure for the different patella positions (in terms of Blackburne-Peel index) at 77 pounds target ankle load.

The average patellofemoral contact pressures recorded during flexion for the different positions of the patella are presented in Figure 6. Between 30° and 45° of flexion, contact pressures were lowest for the higher positions. Lower positions were associated with higher contact pressures in this range of flexion. In deeper flexion (60° to 105°) contact pressures were highest for the higher positions ( $p < 0.01$ ). Patella alta was associated with the highest maximal patellofemoral contact pressure. When averaged across all flexion angles, the normal positions of the patella resulted in the lowest contact pressure.

#### DISCUSSION

We have examined the effect of the height of the patella on patellofemoral contact force, contact area and contact pressure. As flexion increases beyond 60°, the patellofemoral contact force in a high position of the patella increases further and exceeds the contact force that is recorded with a normal patellar height (Fig. 3). A high position is also associated with a greater maximal contact force. These observations are explained by the tendofemoral contact that occurs beyond a certain degree of flexion. This contact leads to load sharing by the quadriceps tendon and a reduction in contact force on the patellofemoral joint during deeper flexion (Table III). Because a higher position causes the tendofemoral contact to occur at a higher angle of flexion, the patellofemoral contact force is



**Figure 7:** Illustration showing the effect of the length of the patellar tendon on the tendofemoral contact, i.e. the contact between the quadriceps tendon and the trochlea. In a short patellar tendon length (a), a broad tendofemoral contact is achieved at 90° of knee flexion. In case of a long patellar tendon (patella alta) (b), this tendofemoral contact is delayed and the entire load at 90° of knee flexion is still supported by the patella itself.

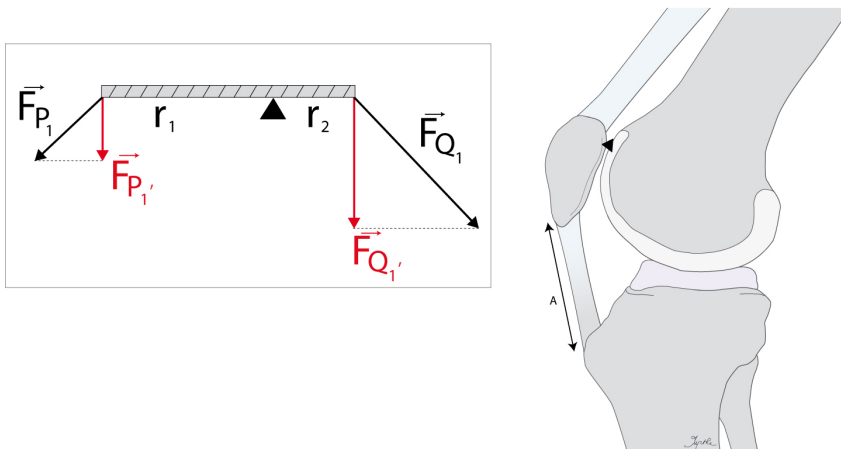
allowed to increase further to a higher maximum (figure 7). For lower positions the opposite is true. In deeper flexion, patella alta can be considered as a biomechanical disadvantage compared to normal patellar height. Huberti and Hayes [18] have described the effect of tendofemoral contact. According to them, at 120° of flexion this contact would support up to half of the total patellofemoral contact force. In patella infera Meyer et al observed load sharing by the tendofemoral contact of up to 80% of the contact force [19].

Our data are consistent with those of Singerman, Davy and Goldberg, who suggested that the patellofemoral contact force depended on patellar height [20]. However, they observed no reduction in contact force after tendofemoral contact had occurred.

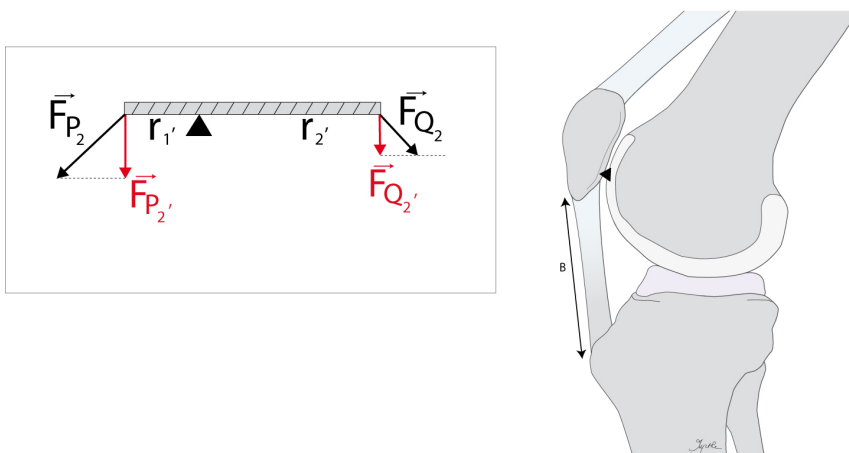
We have also demonstrated that in initial flexion the contact forces on patella alta were smaller than in lower positions of the patella. When the knee is flexed less than 60°, patella alta reduces the contact force, and there is a direct correlation between this reduction and the patellar height.

The biomechanical function of the patella in the extensor mechanism explains these differences in initial flexion. The patella contributes significantly to the torque in knee extension by increasing the lever arm of the quadriceps. The patella also transmits the forces from the quadriceps tendon to the patellar tendon (fig 8). For this, it is free to pivot around its contact point with the femoral trochlea in the sagittal plane, acting as a balancing beam. Because the contact point with the femur lies distally on the normal patella in initial flexion, the effective moment arm of the quadriceps tendon is greater than that of the patellar tendon [10,21,22]. So, in initial flexion, a smaller quadriceps force is needed

to generate a certain patellar tendon force [23]. As patella alta causes a more distal contact point in initial flexion, it reinforces this effect and creates a more efficient knee extensor mechanism (fig 9).



**Figure 8:** The biomechanical effect of a patella baja position on the patellofemoral contact force in early flexion. As the contact point of the patella with the trochlea lies more proximal on the patella compared to the normal situation, the lever arm ( $r_2$ ) of the quadriceps force ( $F_{Q1}$ ) is shorter. Therefore, a greater quadriceps force is needed to create a certain patellar tendon force ( $F_{P1}$ ). As a result, the contact force on the patellofemoral joint becomes greater ( $F_{Q1'}$ )



**Figure 9:** The biomechanical effect of a patella alta position on the patellofemoral contact force in early flexion. As the contact point of the patella with the trochlea lies more distal on the patella compared to the normal situation, the lever arm ( $r_{2'}$ ) of the quadriceps force ( $F_{Q2}$ ) is longer. Therefore, a smaller quadriceps force is needed to create a certain patellar tendon force ( $F_{P2}$ ). As a result, the contact force on the patellofemoral joint becomes smaller ( $F_{Q2'}$ )

The patellofemoral contact force is the sum of the patellar tendon force and the quadriceps tendon force. In our experiment, the patellar tendon force was measured and no significant differences were observed at the different heights of the patella. The reduction in patellofemoral contact force in patella alta is therefore explained by a reduced quadriceps tendon force due to the more efficient extensor mechanism of the knee.



With respect to this, our data are consistent with the previous findings of Ward et al, who were able to demonstrate in an MRI study that individuals with patella alta had a significantly larger quadriceps effective moment arm between 0° and 60° of knee flexion [13]. Based on these findings, they suggested that patients with patella alta may experience less patellofemoral contact force to overcome the same knee flexion moment in the range of 0° to 60°. Our study confirms this hypothesis by direct in vitro measurement of the patellofemoral contact force during a deep knee squat.

The study has a number of limitations. It was undertaken using an artificial implant, which allowed adjustment of the height of the patella easily without destroying the knee. Since the knee simulator was designed with 6° of freedom of movement, the knee was allowed its full spatial freedom so that its kinematics could be closely reproduced [14]. The study was conducted on a morphologically normal knee but patella alta is a component of complex patellofemoral dysplasia in which other factors, such as malalignment and lateral tilt, may influence contact stresses. A recent MRI study showed that patella alta was associated with more lateral displacement and lateral tilt at 0° of flexion, and with a smaller contact area between 0° and 60° of flexion[24]. However, no correlation could be found between malalignment and the reduced contact areas. The authors concluded that these observations warrant careful reconsideration of the previously accepted cause-and-effect relationship between patellofemoral malalignment and reduced patellofemoral contact area. A limitation of our study was that we were unable to take into account the three dimensional behaviour of cartilage at contact and the co-activation of surrounding muscles which occurs during knee flexion and are known to play an important role in patellofemoral kinematics. Nevertheless, we believe our study indicates that, from a biomechanical point of view, patella alta is a less favourable situation in terms of contact force and contact pressure.

With regard to the patellofemoral contact area, we found that for a normal patellar height, the contact area reached a maximum around 90° of flexion and decreased thereafter (Table II). This corresponded with the transition from one central contact area to two separate smaller areas as the patella progressed from the femoral trochlea onto the two condyles at the intercondylar notch (fig 5).

A higher position of the patella corresponded with a lower contact area in initial flexion, whereas a lower position was associated with a higher contact area for the low angles of flexion. These findings are consistent with previous observations [24,25]. Ward et al, in a recent MRI study, concluded that a vertical position of the patella was negatively associated with the contact area between 0° and 60° of knee flexion [24].

Our study also demonstrated that the maximum patello-femoral contact area gradually increased with increasing patellar height. This can be explained by the greater forces observed in deep flexion

for these higher positions. A higher patellofemoral contact force causes more deformation of the articulating surface, resulting in an increased contact area. These data are consistent with previous *in vivo* MRI studies showing a greater contact area in weight-bearing than in non-weight-bearing for a given angle of flexion, indicating that contact area increases with increasing load [26,27].

In initial flexion, contact pressures were the lowest for the higher positions of the patella, whereas lower positions resulted in a higher contact pressure (fig 6). In deeper flexion, however, the contact pressure on the higher patellae was the greatest. The maximal patellofemoral contact pressure increased with increasing patellar height. When averaged across all flexion angles, the normal height of the patella demonstrated the lowest contact pressure and can therefore be considered to be the most favourable.

Patella alta demonstrated the highest maximal patello-femoral contact force and the highest contact pressure when averaged over the whole range of movement. We believe that this is a consequence of the delay in tendofemoral contact and that this may provide a biomechanical explanation for anterior knee pain in patients with patella alta.

## REFERENCES

1. Jordaan G, Schwellnus MP. The incidence of overuse injuries in military recruits during basic military training. *Mil Med* 1994;159:421-6.
2. Levine J. Chondromalacia patellae. *Phys Sportsmed* 1979;7:40-3.
3. Kujala UM, Osterman K, Kvist M, Aalto T, Friberg O. Factors predisposing to patellar chondropathy and patellar apicitis in athletes. *Int Orthop* 1986;10:195-200.
4. Lancourt JE, Christi JA. Patella alta and patella infera: their etiological role in patellar dislocation, chondromalacia, and apophysitis of the tibial tubercle. *J Bone Joint Surg [Am]* 1975;57-A:1112-15.
5. Kannus PA. Long patellar tendon: radiographic sign of patellofemoral pain syndrome: a prospective study. *Radiology* 1992;185:859-63.
6. Bellemans J. Biomechanics of anterior knee pain. *Knee* 2003;10:123-6.
7. Hungerford DS, Barry M. Biomechanics of the patellofemoral joint. *Clin Orthop* 1979;144:9-15.
8. Hehne HJ. Biomechanics of the patellofemoral joint and its clinical relevance. *Clin Orthop* 1990;258:73-85.
9. Grelsamer RP, Weinstein CH. Applied biomechanics of the patella. *Clin Orthop* 2001;389:9-14.
10. Yamaguchi GT, Zajac FE. A planar model of the knee joint to characterize the knee extensor mechanism. *J Biomech* 1989;22:1-10.
11. Hirokawa S. Three-dimensional mathematical model analysis of the patellofemoral joint. *J Biomech* 1991;24:659-71.
12. Meyer SA, Brown TD, Pedersen DR, Albright JP. The effects of patella infera on patellofemoral contact stress. *Trans Orthop Res Soc* 1993;18:303.
13. Ward SR, Terk MR, Powers CM. Influence of patella alta on knee extensor mechanics. *J Biomech* 2005;38:2415-22.
14. Zavatsky AB. A kinematic-freedom analysis of a flexed-knee-stance testing rig. *J Biomech* 1997;20:277-80.
15. Blackburne JS, Peel TE. A new method of measuring patellar height. *J Bone Joint Surg [Br]* 1977;59-B:241-2.
16. Berg EE, Mason SL, Lucas MJ. Patellar height ratios: a comparison of four measurement methods. *Am J Sports Med* 1996;24:218-21.

17. Rogers BA, Thornton-Bott P, Cannon JR, Briggs TW. Interobserver variation in the measurement of patellar height after total knee arthroplasty. *J Bone Joint Surg [Br]* 2006;88-B:484-8.
18. Huberti HH, Hayes WC. Patellofemoral contact pressures: the influence of q-angle and tendofemoral contact. *J Bone Joint Surg [Am]* 1984;66-A:715-24.
19. Meyer SA, Brown TD, Pedersen DR, Albright JP. Retropatellar contact stress in simulated patella infera. *Am J Knee Surg* 1997;10:129-38.
20. Singerman R, Davy DT, Goldberg VM. Effects of patella alta and patella infera on patellofemoral contact forces. *J Biomech* 1994;27:1059-65.
21. Grood ES, Suntay W, Noyes FR, Butler DL. Biomechanics of the knee-extension exercise: effect of cutting the anterior cruciate ligament. *J Bone Joint Surg [Am]* 1984;66-A:725-34.
22. van Eijden TM, Kouwenhoven E, Verberg J, Weijus WA. A mathematical model of the patellofemoral joint. *J Biomech* 1986;19:219-29.
23. Huberti HH, Hayes WC, Stone JL, Shybut GT. Force ratios in the quadriceps tendon and ligamentum patellae. *J Orthop Res* 1984;2:49-54.
24. Ward SR, Terk MR, Powers CM. Patella alta: association with patellofemoral alignment and changes in contact area during weight-bearing. *J Bone Joint Surg [Am]* 2007;89-A:1749-55.
25. Salsich GB, Ward SR, Terk MR, Powers CM. In vivo assessment of patellofemoral joint contact area in individuals who are pain free. *Clin Orthop* 2003;417:277-84.
26. Besier TF, Draper CE, Gold GE, Beaupre GS, Delp SL. Patellofemoral joint contact areas increase with knee flexion and weight-bearing. *J Orthop Res* 2005;23:345-50.
27. Gold GE, Besier TF, Draper CE, Asakawa DS, Delp SL. Weight-bearing MRI of patellofemoral joint cartilage contact area. *J Magn Reson Imaging* 2004;20:526-30.

## 3.2 THE EFFECT OF JOINT LINE ELEVATION ON STRAIN IN THE MEDIAL COLLATERAL LIGAMENT

### 3.2.1 DEVELOPMENT OF A NEW METHOD FOR STRAIN MEASUREMENT IN HUMAN TENDON TISSUE.

#### A. VALIDATION OF DIGITAL IMAGE CORRELATION AS TOOL FOR STRAIN ANALYSIS IN HUMAN TENDON TISSUE.

**T Luyckx, M Verstraete, K De Roo, W De Waele, J Bellemans, J Victor**

Digital Image Correlation as a tool for three-dimensional strain analysis in human tendon tissue. *Journal of Experimental Orthopaedics* 2014 1:7.

#### ABSTRACT

##### **Background**

Determining the mechanical behaviour of tendon and ligamentous tissue remains challenging, as it is anisotropic, non-linear and inhomogeneous in nature.

##### **Methods**

In this study, three-dimensional (3D) digital image correlation (DIC) was adopted to examine the strain distribution in the human Achilles tendon. Therefore, 6 fresh frozen human Achilles tendon specimens were mounted in a custom made rig for uni-axial loading. 3D DIC measurements of each loading position were obtained and compared to 2 linear variable differential transformers (LVDT's).

##### **Results**

3D DIC was able to calculate tendon strain in every region of all obtained images. The scatter was found to be low in all specimens and comparable to that obtained in steel applications. The accuracy of the 3D DIC measurement was higher in the centre of the specimen where scatter values around 0.03 % strain were obtained. The overall scatter remained below 0.3 % in all specimens. The spatial resolution of 3D DIC on human tendon tissue was found to be 0.1 mm<sup>2</sup>. The correlation coefficient between the 3D DIC measurements and the LVDT measurements showed an excellent linear agreement in all specimens ( $R^2=0.99$ ). Apart from the longitudinal strain component, an important transverse strain component was revealed in all specimens. The strain distribution of both

components was of a strongly inhomogeneous nature, both within the same specimen and amongst different specimens.

### **Conclusion**

DIC proved to be a very accurate and reproducible tool for 3D strain analysis in human tendon tissue.

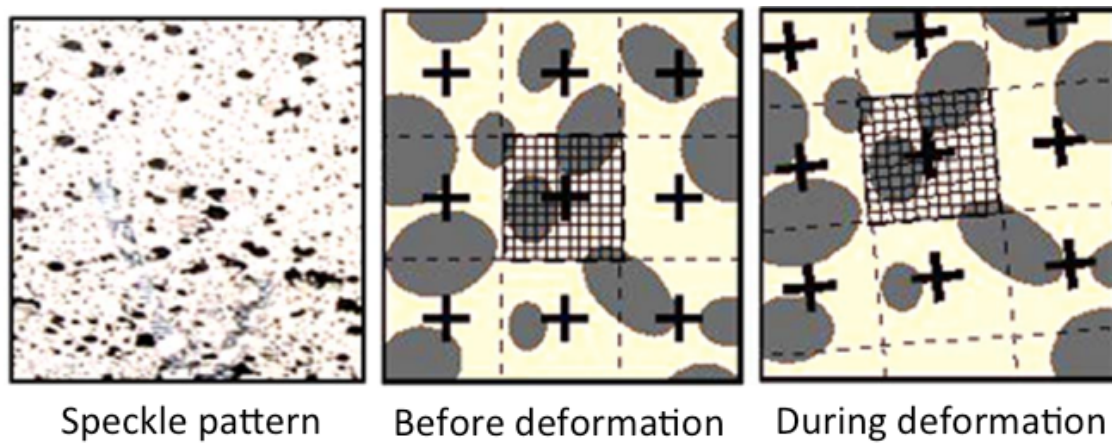
### **BACKGROUND**

Measuring the mechanical behaviour of human soft tissue remains challenging. As human soft tissue is anisotropic, non-linear and inhomogeneous in nature, its properties are difficult to characterize. Different methods have been described that are either based on contact or noncontact measurement techniques. Classically, several types of strain gauges have been used. The major downside of these measurement tools is that they are invasive in nature and act as single-point gauges, which can only record strain from one small area. Even several strain gauges cannot show regional strain and strain gradients and thus could miss critical details. Moreover, many designs only measure strain in one direction (uni-directional strain).

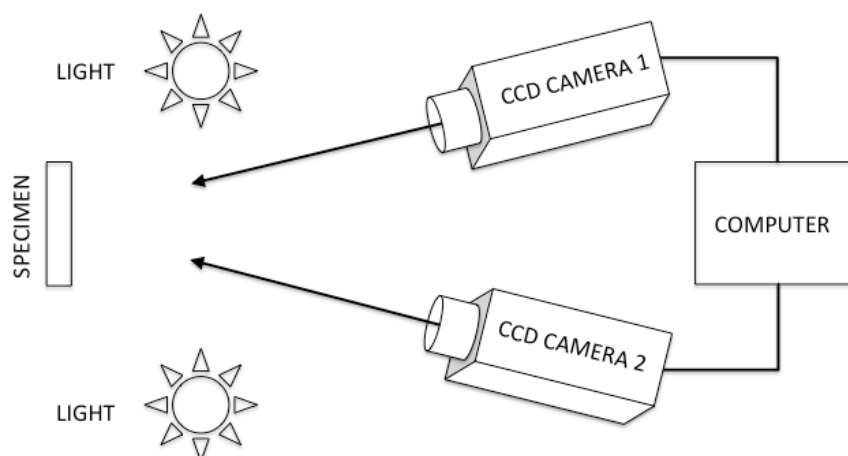
Image-based strain measurements on the other hand are non-invasive. Many of them optically track surface markers on the specimen during deformation to inversely calculate displacements and strain. Their resolution is mainly defined by the distance between the markers on the surface and was fairly low in many setups [1–3]. Digital image correlation (DIC) is an optical method for strain measurement that uses image recognition to analyse and compare digital images acquired from the surface of a substrate instead of surface markers [4]. By tracing a randomly applied high contrast speckle pattern using white light, displacement and strain within the specimen can be calculated from subsequent images (fig 1). The initial imaging processing defines unique correlation areas known as macro-image facets, typically 5–20 pixels square, across the entire imaging area. Each facet is a measurement point that can be thought of as an extensometer point and strain rosette. These facets are tracked in each successive image with sub-pixel accuracy and from their displacement, strain can be calculated. Using one camera only allows for single plane measurements (2D). In this setup, out of field displacement can cause significant error. Transition to the use of 2 charge-coupled device (CCD) cameras enables three-dimensional (3D) deformation analysis of the whole area of interest and has overcome this error (fig 2). As with stereopsis, the use of the 2 different images of the same object and the photogrammetric principles enable the calculation of the precise 3D coordinates of each point of the entire surface. In this way, a high-resolution 3D map with strain magnitude, gradient and distribution of the entire study object can be obtained. Another major

benefit is that the results from a DIC experiment are directly comparable to finite element models for model verification, iteration and boundary verification.

Despite its wide adoption in engineering research and its great potential for strain and displacement measurements in biological tissue, the reported biomechanical applications are rather limited. Some authors reported on DIC to analyse strain distribution in arterial tissue [4,5], bovine cornea [6], human tympanic membrane [7], stapedial tendon [8], cartilage [9], composite bones [10–12] and cortical bone [13–18]. More recently, optical 2D DIC strain measurements were compared to dynamic ultrasound and ultrasound elastography measurements on animal tendon tissue, showing excellent correlation [19,20]. To our knowledge, no reports or validation of 3D DIC measurement on human tendon tissue exist.



**Figure 1:** Digital image correlation traces the deformation of a random speckle pattern during loading. A facet, composed of a subset of image pixels represented by the grid, is used to track the speckle pattern and measure its displacement [15].



**Figure 2:** Typical setup of a DIC experiment. Using two 2 charge-coupled device (CCD) cameras enables three-dimensional (3D) deformation analysis

The tensile properties of the Achilles tendon have been extensively studied both in vivo and in vitro [21–23]. Wren et al. already showed that the strain distribution in the Achilles tendon is inhomogeneous [24]. However, spatial resolution of the measurement method was low and thus local strain distribution could not be quantified. The link with clinical failure patterns remains unclear.

The first goal of this study was to determine the feasibility to evaluate the mechanical properties of the human Achilles tendon under uniaxial loading conditions with 3D Digital Image Correlation. The second goal was to compare the accuracy and reproducibility of the 3D DIC against two Linear variable differential transformers (LVDT's).

The hypothesis for this study was that 3D DIC would be as accurate as LVDT's in determining longitudinal strain in the human Achilles tendon and that 3D DIC would enable a full field multi-directional strain analysis of the tendon tissue.

## METHODS

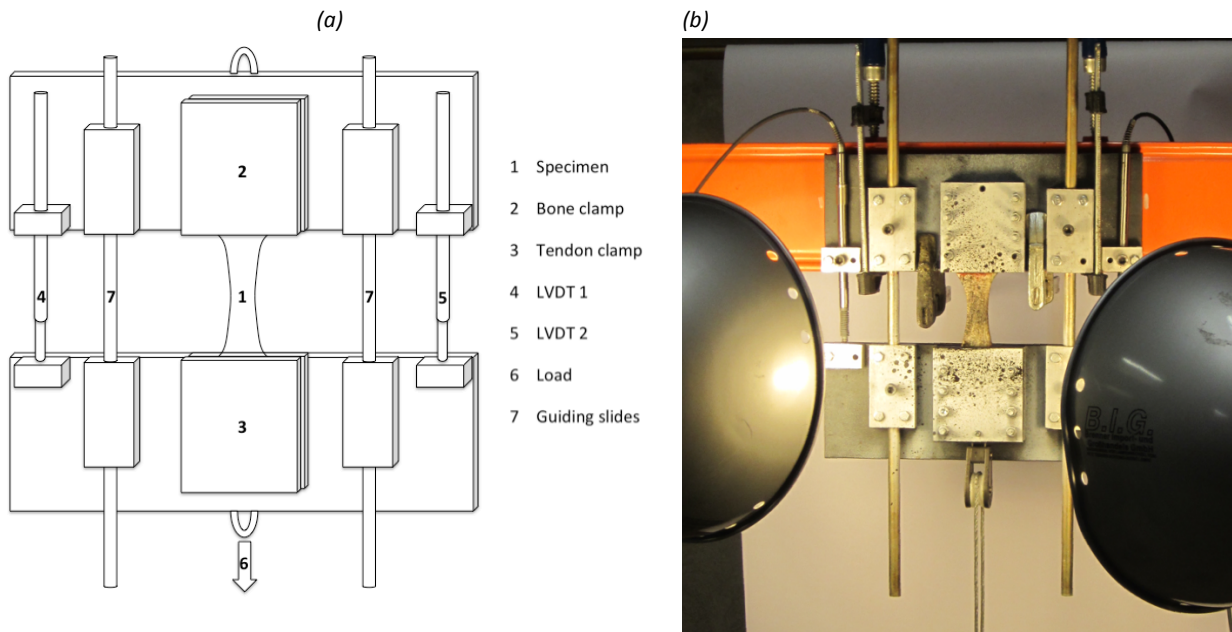
The research protocol was reviewed and approved by the institutional review board of the University of Ghent. Six paired fresh frozen full limb specimens were obtained (3 left and 3 right) from 3 human donors. The mean age of the specimens was 62,3 years. The demographic variables of the specimens are described in Table 1. The specimens were stored at  $-22^{\circ}\text{C}$  prior to the experiment.

Donor nr	Sex	Age	Weight (kg)
Donor A	Male	48	64
Donor B	Male	69	90
Donor C	Female	70	40

**Table 1:** Demographic data of the specimens

The day before the experiment the specimen was taken out of the freezer to allow 12 hours of thawing at room temperature ( $20^{\circ}$ ). Next, the whole Achilles tendon was prelevated from each specimen with a calcaneal bone block. All soft tissues including the paratenon were removed from around the tendon. The calcaneal bone block was clamped between two steel plates with a rim on the end. The proximal part of the Achilles tendon was fixed in a custom made clamp with a polymer toothed rack. The tendon was kept moist at all time during the experiment using a wet cloth and water spray.

A custom made rig was used to apply a progressive load to the specimen (fig 3). To prevent rotation of the specimen, the lower part of the rig moved over two slides. To assess the accuracy and reproducibility of 3D DIC, the displacement between the clamps was measured with two Linear Variable Differential Transformers (LVDTs), which measure linear displacement with an accuracy of 1  $\mu\text{m}$ . The LVDTs were mounted in the frame next to the tendon. Calibrated photograph images were taken from each setup to allow accurate post-processing of the measurements.

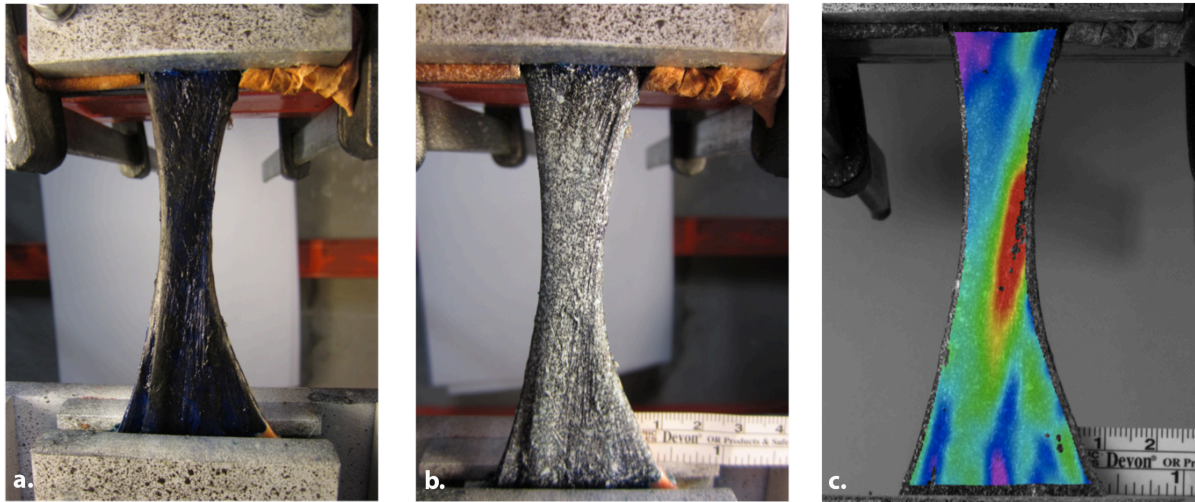


**Figure 3:** Schematic diagram of the Uniaxial loading rig (a) and the complete test setup with 2 halogen lamps to optimise image contrast (b).

### *Specimen preparation*

A modified tendon preparation technique was introduced to overcome some issues with DIC on human tendon tissue (see Discussion). The specimen was therefore first dyed with methylene blue making it appear dark blue. Methylene blue dissolved in water, penetrates the tissue colouring it in its typical dark blue colour without leaving a coat on the tissue. In this way, direct attachment of the speckle pattern onto the tissue is obtained. The dark matt background also reduced scatter. The speckle pattern is then applied with an airbrush in a matte water-based white paint instead of black paint. In this way, an optimal contrast was obtained (fig 4).



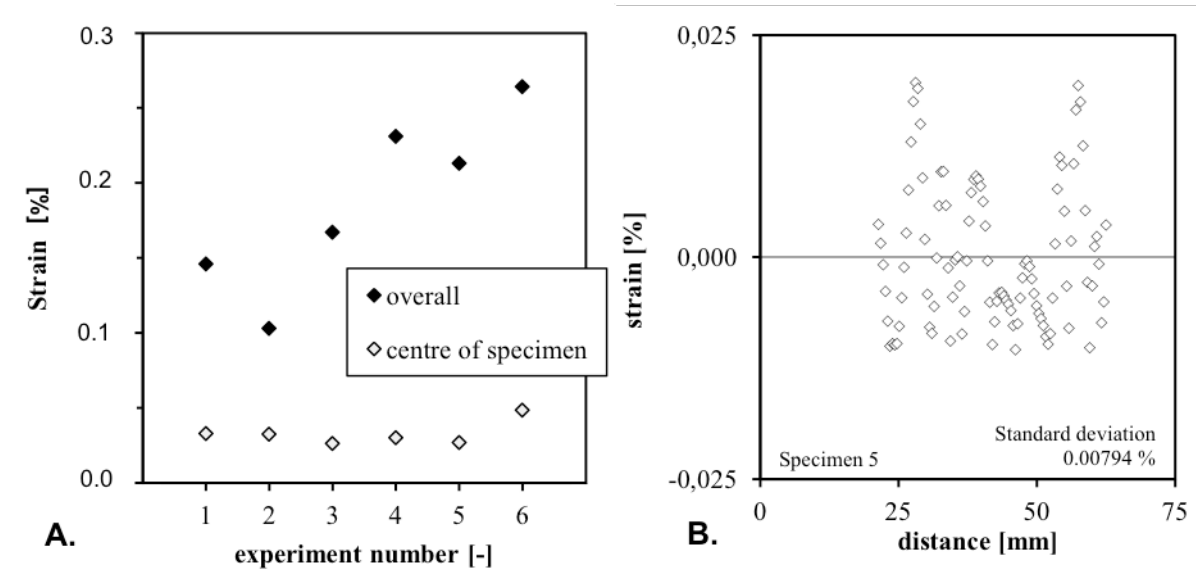


**Figure 4:** The Achilles tendon in the clamps dyed with methylene blue (a), speckled with white paint (b) and the 3D DIC strain map plotted on the specimen showing the longitudinal strain (c).

#### *Digital image correlation*

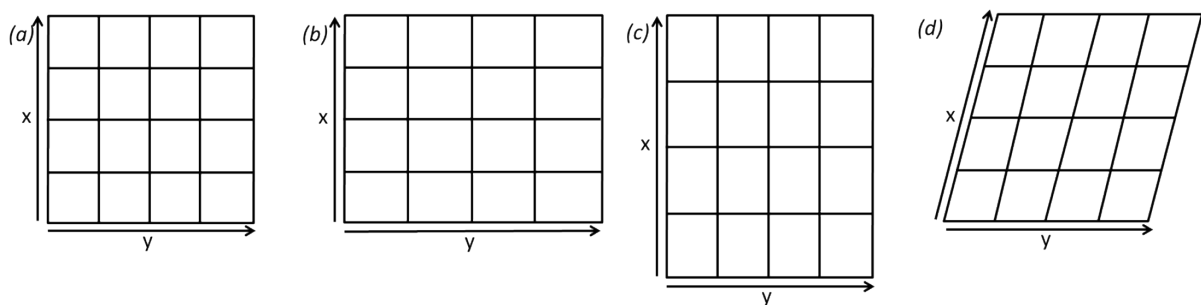
Two CCD cameras with a resolution of  $2486 \times 1985$  pixels (Limes GmbH, Pforzheim, Germany) mounted on a tripod were positioned vertically in front of the loading rig and both cameras were plugged into the computer and connected to the DIC software Vic3D 2006 (Correlated Solutions, Columbia, South Carolina). A pair of halogen lamps (20 W, 150 mA, 1200 lumen, Philips Tornado) was positioned to optimize illumination and contrast of the specimen (fig 3). A white screen was mounted behind the specimen for the same reason. The relative position of the cameras with respect to each other was calibrated using a high-precision  $12 \text{ mm} \times 9 \text{ mm}$  calibration target. Prior to the actual measurement, multiple images were captured from the preloaded condition of the specimen for an evaluation of the accuracy of the strain measurement [15]. During the test, 3 subsequent images were taken from each loading position to assess the experimental noise at the different loading conditions. The accuracy was determined in terms of scatter in the strain measurements that was measured on these images (fig 5). This was done in two ways. First, the difference between the minimum and maximum strain in the overall field was evaluated. Second, the scatter in the centre-most part of the specimen was evaluated. The second method is applied to overcome disturbing effects from the boundaries of the analysed area, as it is well known that the correlation is less accurate at edges and higher strains are also observed near the site of tissue clamping [19]. The surfaces of the clamps of the rig were prepared for DIC measurement with a white basic paint and a black speckle pattern. In this way, the distance between the two clamps was recorded using the DIC as a virtual LVDT (fig 7). For all specimens, the displacement of the grips (grip-to-grip strain), obtained through DIC (hereafter referred to as ‘DIC-1’), was compared to the average measured

displacements of the two LVDT's fixed aside the grips. In addition to the displacement of the grips, the displacements were obtained on the specimen itself, adjacent to the grips (hereafter referred to as 'DIC-2'). The difference between the DIC-1 and DIC-2 measurements quantified the slip in the grips.



**Figure 5:** Overview of the obtained scatter in all specimens both at the centre part and the whole tendon (a). A typical example of central area for specimen 5 is shown in detail (b).

From the obtained displacements, the corresponding strain components were derived (fig 6). The longitudinal strain ( $\epsilon_{yy}$ ) was defined as strain occurring in direction of the applied load. Transverse strain ( $\epsilon_{xx}$ ) was defined as strain measured in a direction perpendicular to the applied load. The shear strain ( $\epsilon_{xy}$ ) was defined as strain occurring in a direction angulated  $45^\circ$  to the longitudinal and transverse strain.



**Figure 6:** Types of deformation: (a) Undeformed state, (b) longitudinal ( $\epsilon_{yy}$ ), (c) transverse ( $\epsilon_{xx}$ ) and (d) shear strain ( $\epsilon_{xy}$ )

To evaluate the effect of preconditioning of the tendon, a load of 607,8 N was applied during 10 minutes in specimen 4 to 6. The results for the Young’s modulus are shown in Table 2 and figure 8. Progressive static loading of the tendon up to 628,3 N and subsequent unloading was performed with calibrated weights. The preload was 48,9 N, additional loading in the first ten steps was done per 10 N until 100 N, from then on steps of 25 N were used until maximum load of 628,3 N. At maximum load, the specimens were kept at constant force for roughly two minutes before unloading. The stress–strain relationship is shown in Figure 4. Unloading was done in steps of 50 N. Three DIC frames of each loading position were recorded. LVDT’s attached next to the tendon continuously recorded displacement between the clamps.

	Donor	Pre-loaded	Young’s Modulus (MPa)
Spec 1	Donor A Left	No	387,97
Spec 2	Donor B Left	No	294,83
Spec 3	Donor B Right	No	371,23
Spec 4	Donor C Left	Yes	514,68
Spec 5	Donor A Right	Yes	573,27
Spec 6	Donor C Right	Yes	787,68

**Table 2:** Effect of pre-conditioning on the Young’s modulus for each specimen.

### Statistical analysis

For the accuracy analysis, values were obtained based on 95% confidence interval and assuming a normal distribution. A Pearson correlation test was used to evaluate the correlation between the LVDT measurements and the DIC-1 measurements. All analyses were performed using SPSS software for Mac (version 22; SPSS Inc., Chicago, Illinois).

## RESULTS

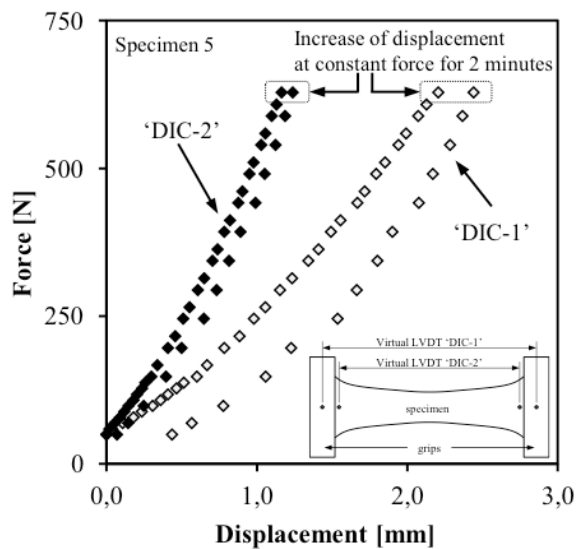
### *Accuracy analysis and comparison to LVDT measurements*

3D DIC was able to calculate tendon strain in every region of all obtained images. The scatter was found to be low in all specimens. The accuracy of the DIC measurement was higher in the centre of

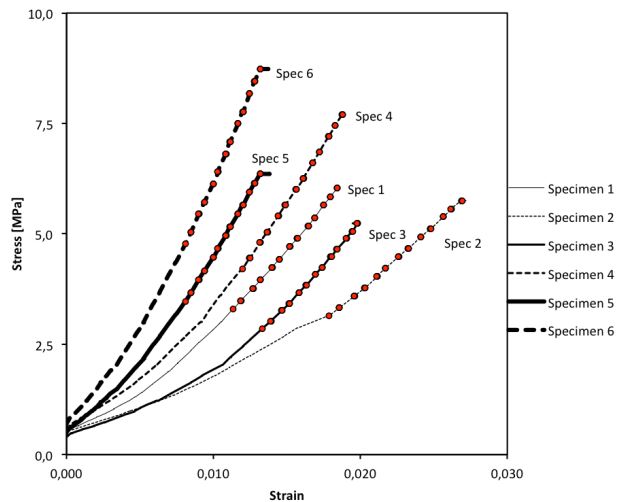
the specimen where scatter values of on average 0.03% (SD 0.00794%) strain were obtained (fig 5). The overall scatter remained below 0.3% in all specimens. The spatial resolution of 3D DIC on human tendon tissue was found to be 0.1 mm<sup>2</sup>.

The correlation coefficient between the 3D DIC measurements and the LVDT measurements showed an excellent linear agreement in all specimens ( $R^2 = 0.99$ ). The mean intercept and the slope of the linear correlation were 0.000 and 0.982 respectively.

Comparison of DIC-1 and DIC-2 measurements as a function of the applied load revealed a significant slip in the clamps (fig 9). The relative error originating from not subtracting the slip in the clamps was evaluated in order to quantify the importance of the slip. Distinction is made between clamping at the tendon tissue and clamping at the bone block. The bone block clamping showed a higher slip rate. The slip at the clamps represented on average 53% of the total displacements, resulting in an overestimation of the strain in the tendon by a factor of approximately 2 if only LVDT would have been used as measurement tool. By using DIC-2 the analysis became independent of any slip.



**Figure 7:** A typical force-displacement curve of specimen 5. Both loading and unloading phase are shown. At maximum load, the specimens were kept at constant force for roughly two minutes before unloading. For the displacements measured on the specimens (DIC-2) the difference between loading and unloading was allocated to hysteresis. For the grip-to-grip measurements (DIC-1), the difference was mainly the consequence of slip in the grips.



**Figure 8:** Stress-strain curves for all 6 specimens. The marks were placed on the linear part of the curve. The  $E$  modulus was determined from the slope of this part of the curve for each specimen. Specimen 1, 2 and 3 were not pre-loaded. Specimen 4, 5 and 6 were pre-loaded. Cfr table 2.

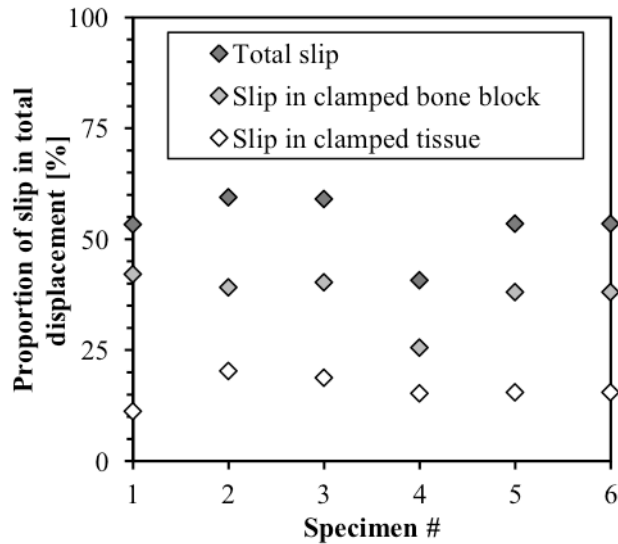
### *Strain distribution during loading cycle*

The distribution of the average strain, measured over a circular central area with a diameter of 4.0 mm, as function of the applied load is shown in Figure 10. Apart from longitudinal strains ( $\epsilon_{yy}$ ), even larger transverse strains ( $\epsilon_{xx}$ ) were observed in all specimens. The shear deformation ( $\epsilon_{xy}$ ) was limited and remained close to zero during the entire test in all specimens. The presence of large positive transverse strains means that the specimen deformed (got wider) as the applied load increased. Part of the deformation was permanent (fig 10).

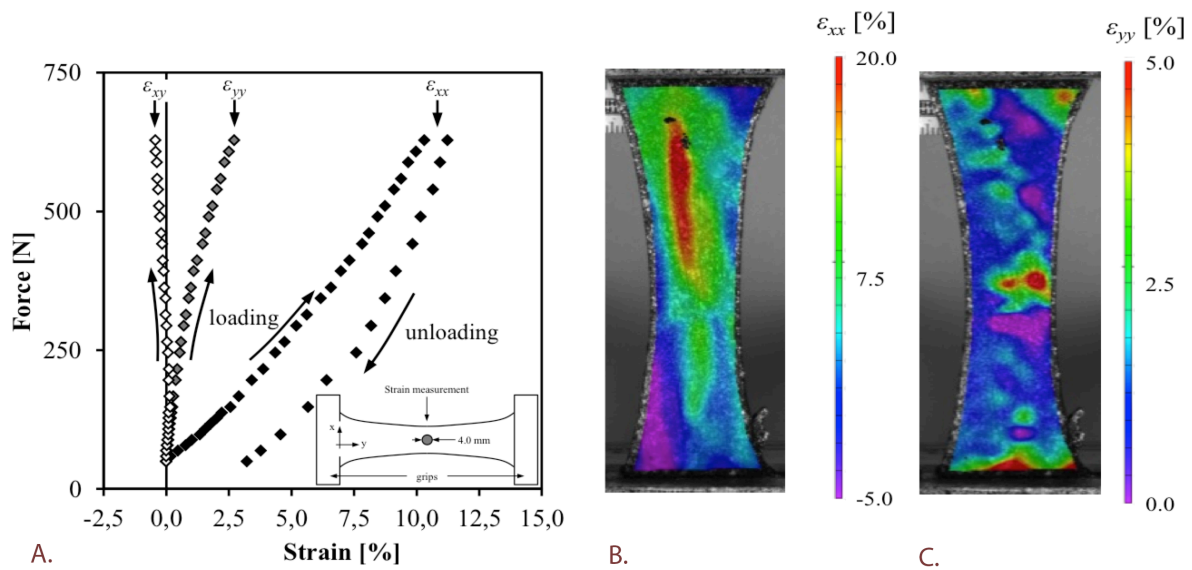
### *Cumulative strain distribution*

From the full field measurements, the strain can be evaluated at every tracked point of the tendon. This revealed significant regional inhomogeneity within each specimen and also between the different specimens. Although this provides in-depth insights related to the mechanical behaviour of the tendon, such approach is impractical given the strongly inhomogeneous nature of the deformation fields (fig 11). By means of illustration, a typical DIC movie showing the loading and the unloading phase of the specimen is provided in the Additional files 1 and 2.

To overcome the practical issues with the analysis of the data due to the local heterogeneity of the different strain maps, a cumulative strain distribution was created. To that extent, the analysed area is subdivided in squares of  $1 \times 1$  mm and the strain is evaluated at the centre of each square. Subsequently, a cumulative distribution for the whole tendon was created for each specimen meaning that for x% of strain, the relative surface area demonstrating less than or equal to x% of strain was calculated. The cumulative distribution of specimen 5 plotted in Figure 11A showed an increasing inhomogeneity with increasing load. The cumulative distribution was obtained at maximum load for all specimens (Figure 11B), indicating that approximately 60% of the surface of each tendon has strain values between 0 and 2%. Except for specimen 1, a strain exceeding 5% (the assumed damage threshold) was only found in 10% or less of the surface area of the tendons.



**Figure 9:** The difference between DIC 1 and DIC 2 measurements was plotted for each specimen. In this way, the slip in the grips was quantified. A distinction between the bone block clamp and the tissue clamp was made with the latter showing significant less slip.

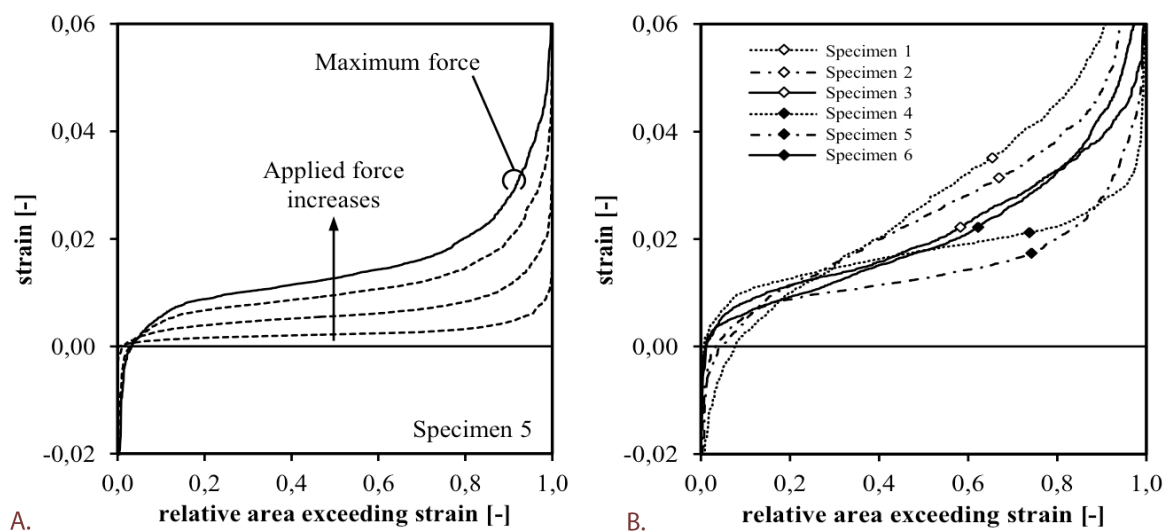


**Figure 10:** Evolution of strain components over central area of specimen 5 as function of the applied force (a). The shear strain  $\epsilon_{xy}$  remained close to zero during the experiment. The corresponding strain maps at maximal load showing the transverse strains  $\epsilon_{xx}$  (b) and longitudinal strains  $\epsilon_{yy}$  (c) are also given.

## DISCUSSION

With this study, we validated the use of 3D DIC as a highly accurate optical strain measurement tool on human tendon tissue. Despite its wide adoption in engineering research and its great potential for strain and displacement measurements in biological tissue, the reported biomedical applications are rather limited. It is our belief that the major reason for this is the technical difficulties that had to be overcome when performing 3D DIC experiments on human tissue. First of all, obtaining optimal contrast can be challenging. Most frequently, a black paint is used on a background that is light in colour. This works well on meticulously prepared fresh frozen tendon tissue, which is indeed white. However, ligaments, retinacula and fascia appear less light in colour and are difficult to examine. For specimens that are darker, the application of a matte white background is advised prior to depositing the final coating of black dots [4]. This introduces a layer between the surface of the specimen and the speckle pattern, which can cause measurement error, as the speckle pattern is no longer directly attached to the surface of the tissue. Secondly the fact that biological tissue is hydrated and has to be moist at all time of the experiment, poses some difficulties. It can be challenging to apply a speckle pattern on a moist surface. Fast-drying paint is therefore required. A moist surface also introduces scatter when the illumination is not appropriately adapted. Finally, on a moist surface, fluid drops can form during the experiment, making correlation in that region impossible. In this paper, a modified preparation technique using methylene blue was introduced. With this technique, the surface of the tendon was first dyed dark blue and then a white speckle pattern was applied. This modification, which is basically an inversion of the contrast pattern (white on black instead of black on white), can deal with most of the described problems [25]. Methylene blue is a hydrophilic molecule that is still frequently used during surgery as a method for marking soft tissue [26]. Modified tendon properties have not yet been reported with methylene blue. Moreover, in our study the methylene blue was only applied to the surface of the tendon thereby avoiding influence on the mechanical properties of the bulk of the tendon tissue. Previous techniques advocate the application of a basic layer of white paint on the study specimen before applying the black speckle pattern [4]. The major advantage of our methylene blue technique is that in our technique the speckles remain directly attached to the soft tissues as methylene blue infiltrates between the collagen fibers instead of applying an extra layer onto the surface of the tendon. It is noted that the standard deviation of the strains in the specimen is of the same order of magnitude as in experiments on the steel blocks. Thus, it is concluded that the accuracy on tendon tissue was very high. This adaption might expand the research applications of 3D DIC to other human collagenous tissues like ligaments and retinacula that were otherwise difficult to examine because of the lack of contrast [27].

Some authors reported on DIC to analyse strain distribution in arterial tissue [4,5], bovine cornea [6], cartilage [9], composite bones [10–12] and cortical bone [13–18]. In most of these reports, a 2D technique is used. To our knowledge, this is the first validation report of 3D DIC measurement on human tendon tissue. The major advantage of 3D DIC over the 2D analysis is the fact that rigid body motions can be calculated from the original pixel registration and thus can be subtracted. This opens perspective for strain measurement on a moving object (e.g. knee squat) [27]. The 2 CCD camera setup allows the calculation of a detailed 3D surface coordinate map. Stain and strain gradients can be plotted on this map.



**Figure 11:** (a) The cumulative strain distribution of specimen 5 at different loading conditions and (b) the cumulative strain distribution for all specimens at maximum load. The X-axis represents the relative surface area of the specimen. The Y-axis represents strain. In this way, the relative surface area showing a strain of less than and equal to a certain value is plotted. E.g. in graph (a) for specimen 5, at maximum load, 80% of the surface area of the tendon showed a strain of less than or equal to 2%.

3D DIC enabled visualisation of multidirectional strain components that would have been missed using classic strain gauges. In our experiment for example, a significant amount of strain was observed in a direction perpendicular to the applied load (fig 10). This transverse strain exceeded the longitudinal strain component. Although it appears counterintuitive, this was expected, as the specimens were slightly convex. Accordingly, the convexity decreases when loaded in longitudinal tension. The specimens got straighter and thus wider, mainly in their central portion. All previous Achilles tendon loading experiments were not able to capture this transverse strain component. It might in fact have an influence on the observed tendon rupture patterns. Also shear strain could be quantified from our data.



Due to its non-contact nature, the 3D DIC was able to quantify and subtract the slip that is inevitably seen at any tendon-grip interface. In this way, our analysis became independent of any slip at the grips. Failure to subtract this slip might be part of the explanation for the large variance in failure stresses (38–86 MPa) and failure strains (7,5 – 16,1%) for the Achilles tendon reported in literature [21,24,28].

As 3D DIC provided a high-resolution full field analysis, data of the whole tendon at sub-pixel level were provided. This enabled us to visualise the regional inhomogeneity in strain distribution that is typical for biological tissue. This regional inhomogeneity stresses the importance of doing such a full field analysis. Classic strain gauges are not able to provide these data unless an infinite number of them would be used. This is in fact how the 3D DIC technique should be looked at. It was shown that regional strain could be quite different from the overall strain in a specimen. To capture all the data provided by the strain map, the cumulative strain distribution was introduced (Figure 8). In contrast to Young's modulus, this tool is independent of the volume of the clamped tendon and might therefore shed a new light over failure patterns in tendon tissue. It is frequently observed in strain experiments that maximum mid-substance strains are smaller than the grip-to-grip strain [19]. This phenomenon is well documented in the literature [29], and is likely the result of higher strains arising near the site of tissue clamping and slip at the grip-tendon interface. Therefore, instead of defining tendon failure by a certain grip-to-grip strain during a loading experiment (e.g. 10%), it could be more appropriate to state that tendon failure occurred when a certain percentage its surface area (e.g. 30%) reached a certain threshold of strain (e.g. 8%). This cumulative failure strain will in fact be lower than the corresponding grip-to-grip strain due to the regional inhomogeneity in strain distribution. As relative surface area (%) is used in this measure, it becomes independent of tendon volume. This cumulative distribution can thus provide important insight in the displacement energy absorption within the tendon and might show better correlation with damage accumulation and failure patterns. Part of our further research will therefore focus on the validation of the cumulative strain distribution and the determination of the cumulative damage and failure thresholds in different tendon tissues.

One of the downsides of this study is the rather limited sample size of six specimens. Nevertheless, the correlation between the measurement methods was found to be linear and strong. Adding more specimens would therefore not change the statistical conclusion. Another downside of the DIC technique is that its analysis is limited to the properties of the superficial layer of a tissue sample. However, the potential of using the surface measurement of 3D DIC to assess mechanical states throughout the bulk of a tissue has been suggested [30]. Moerman et al. showed that the use of 3D DIC in combination with inverse finite element analysis is a valuable tool to non-invasively determine

the bulk material properties of soft tissue [31]. The use of Methylene blue might also influence the tendon properties. However, this was not reported so far. We minimised a potential effect by only applying methylene blue to the surface of the tendon. In this way, an influence on the mechanical properties of the bulk of the tendon tissue was avoided. The fact that a contrast pattern has to be applied, limits the research possibilities of the technique mainly to ex-vivo experiments. Recent research has focused on the possibilities of the digital image correlation technology to track the texture of ultrasound images. As ultrasound is frequently used to image musculoskeletal tissue, this technique allows in vivo strain measurement. Several authors showed an excellent correlation between classic 2D DIC measurements and 2D ultrasound elastography [19,20,32].

## CONCLUSION

3D DIC proved to be a very accurate and reproducible tool for strain measurement in human tendon tissue. The introduction of a high-resolution full field strain analysis might shed a new light over previous insights in damage accumulation and failure patterns of tendon tissue. Further research will be directed to these topics.

## REFERENCES

1. Mazzocca AD, Rincon LM, O'Connor RW, Obopilwe E, Andersen M, Geaney L, Arciero RA (2008) Intra-articular partial-thickness rotator cuff tears: analysis of injured and repaired strain behavior. *Am J Sports Med* 36(1):110–116.
2. Dy CJ, Thompson MT, Crawford MJ, Alexander JW, McCarthy JC, Noble PC (2008) Tensile strain in the anterior part of the acetabular labrum during provocative maneuvering of the normal hip. *J Bone Joint Surg Am* 90(7):1464–1472.
3. Noble P, Patel R, Ashfaq K, Bernstein D, Ismaili S, Incavo S (2013) Does TKR lead to an increase in lateral retinacular strain with flexion? *Bone & Joint Journal Orthopaedic Proceedings Supplement* 95-B(SUPP 34):138.
4. Zhang D, Arola DD (2004) Applications of digital image correlation to biological tissues. *J Biomed Opt* 9(4):691–699.
5. Sutton MA, Ke X, Lessner SM, Goldbach M, Yost M, Zhao F, Schreier HW (2008) Strain field measurements on mouse carotid arteries using microscopic three-dimensional digital image correlation. *J Biomed Mater Res* 84(1):178–190.
6. Boyce BL, Grazier JM, Jones RE, Nguyen TD (2008) Full-field deformation of bovine cornea under constrained inflation conditions. *Biomaterials* 29(28):3896–3904.
7. Cheng T, Dai C, Gan RZ (2007) Viscoelastic properties of human tympanic membrane. *Ann Biomed Eng* 35(2):305–314.
8. Cheng T, Gan RZ (2007) Mechanical properties of stapedial tendon in human middle ear. *J Biomech Eng* 129(6):913–918.
9. Zhang J, Jin GC, Meng LB, Jian LH, Wang AY, Lu SB (2005) Strain and mechanical behavior measurements of soft tissues with digital speckle method. *J Biomed Opt* 10(3):034021.

10. Dickinson AS, Taylor AC, Ozturk H, Browne M (2011) Experimental validation of a finite element model of the proximal femur using digital image correlation and a composite bone model. *J Biomech Eng* 133(1):014504.
11. Dickinson AS, Taylor AC, Browne M (2012) The influence of acetabular cup material on pelvis cortex surface strains, measured using digital image correlation. *J Biomech* 45(4):719–723.
12. Tayton E, Evans S, O'Doherty D (2010) Mapping the strain distribution on the proximal femur with titanium and flexible-stemmed implants using digital image correlation. *J Bone Joint Surg* 92(8):1176–1181.
13. Nicoletta DP, Nicholls AE, Lankford J, Davy DT (2001) Machine vision photogrammetry: a technique for measurement of microstructural strain in cortical bone. *J Biomech* 34(1):135–139
14. Nicoletta DP, Bonewald LF, Moravits DE, Lankford J (2005) Measurement of microstructural strain in cortical bone. *Eur J Morphol* 42(1–2):23–29.
15. Sztetek P, Vanleene M, Olsson R, Collinson R, Pitsillides AA, Shefelbine S (2010) Using digital image correlation to determine bone surface strains during loading and after adaptation of the mouse tibia. *J Biomech* 43(4):599–605.
16. Hoc T, Henry L, Verdier M, Aubry D, Sedel L, Meunier A (2006) Effect of microstructure on the mechanical properties of haversian cortical bone. *Bone* 38(4):466–474.
17. Yang L, Zhang P, Liu S, Samala PR, Su M, Yokota H (2007) Measurement of strain distributions in mouse femora with 3D-digital speckle pattern interferometry. *Opt Lasers En* 45(8):843–851.
18. Thompson MS, Schell H, Lienau J, Duda GN (2007) Digital image correlation: a technique for determining local mechanical conditions within early bone callus. *Med Eng Phys* 29(7):820–823.
19. Chernak Slane L, Thelen DG (2014) The use of 2D ultrasound elastography for measuring tendon motion and strain. *J Biomech* 47(3):750–754.
20. Okotie G, Duenwald-Kuehl S, Kobayashi H, Wu MJ, Vanderby R (2012) Tendon strain measurements with dynamic ultrasound images: evaluation of digital image correlation. *J Biomech Eng* 134(2):024504.
21. Louis-Ugbo J, Leeson B, Hutton WC (2004) Tensile properties of fresh human calcaneal (Achilles) tendons. *Clin Anat* 17(1):30–35.
22. Komi PV, Fukashiro S, Jarvinen M (1992) Biomechanical loading of achilles tendon during normal locomotion. *Clin Sport Med* 11(3):521–531.
23. Lewis G, Shaw KM (1997) Tensile properties of human tendo achillis: effect of donor age and strain rate. *J Foot Ankle Surg* 36(6):435–445.
24. Wren TA, Yerby SA, Beaupre GS, Carter DR (2001) Mechanical properties of the human achilles tendon. *Clin Biomech (Bristol, Avon)* 16(3):245–251.
25. Verstraete M, Luyckx T, De Roo K, Dewaele W, Bellemans J, Victor J (2013) Validation of digital image correlation (DIC) as a tool for Non-contact three-dimensional strain analysis of human tendon tissue. *Bone & Joint Journal Orthopaedic Proceedings Supplement* 95(SUPP 34):189.
26. Tuite EM, Kelly JM (1993) Photochemical interactions of methylene blue and analogues with DNA and other biological substrates. *J Photochem Photobiol B Biol* 21(2–3):103–124.
27. Luyckx T, Verstraete M, De Roo K, Dewaele W, Victor J, Bellemans J (2013) The effect of single radius TKA implantation and joint line proximalisation on the strain pattern in the sMCL of the knee. *Bone & Joint Journal Orthopaedic Proceedings Supplement* 95(SUPP 34):401.
28. Thermann H, Frerichs O, Biewener A, Krettek C, Schandelmaier P (1995) Biomechanical studies of human achilles tendon rupture. *Unfallchirurg* 98(11):570–575.
29. Haraldsson BT, Aagaard P, Krogsgaard M, Alkjaer T, Kjaer M, Magnusson SP (2005) Region-specific mechanical properties of the human patella tendon. *J Appl Physiol* 98(3):1006–1012.
30. Spencer M, Siegmund T, Mongeau L (2008) Determination of superior surface strains and stresses, and vocal fold contact pressure in a synthetic larynx model using digital image correlation. *J Acoust Soc Am* 123(2):1089–1103.
31. Moerman KM, Holt CA, Evans SL, Simms CK (2009) Digital image correlation and finite element modelling as a method to determine mechanical properties of human soft tissue in vivo. *J Biomech* 42(8):1150–1153.
32. Chernak LA, Thelen DG (2012) Tendon motion and strain patterns evaluated with two-dimensional ultrasound elastography. *J Biomech* 45(15):2618–2623.

*B. APPLICATION OF DIGITAL IMAGE CORRELATION FOR 3D STRAIN ANALYSIS OF THE SUPERFICIAL MEDIAL COLLATERAL LIGAMENT OF THE KNEE*

**T Luyckx, M Verstraete, K De Roo, C Van Der Straeten, J Victor**

High strains near femoral insertion site of the superficial medial collateral ligament of the knee can explain the clinical failure pattern.

Revised manuscript under consideration for the Journal of Orthopaedic Research.

**ABSTRACT**

**Purpose:**

This study was set up to investigate the three dimensional (3D) deformation and strain distribution of the superficial medial collateral ligament (sMCL) of the knee.

**Methods:**

In five fresh frozen cadaveric knees, the strain and deformation pattern of the sMCL during the range of motion was recorded using 3D digital image correlation.

**Results**

The central part of sMCL was almost perfectly isometric between 15° and 90° of flexion (< 0.3% strain). However, significant regional inhomogeneity was observed. The strains in the proximal part of the sMCL were significantly higher than in the other parts with a positive strain of up to 5%.

During knee flexion, the sMCL was deformed in the 3 planes. In the sagittal plane, a rotation of the proximal part of the sMCL relative to the distal part occurred with the centre of this rotation being the proximal tibial insertion site of the sMCL. The rotation angle averaged 14° at 120° of flexion.

**Conclusion**

The sMCL can be considered as a perfectly isometric ligament between 15° to 90° of knee flexion. However, significant regional inhomogeneity in strain and significant deformation in the three planes were observed. The highest strains were observed near the femoral insertion site. This might explain why most lesions in clinical practice are seen in that region.

## INTRODUCTION

As the primary static stabiliser preventing valgus rotation, the medial collateral ligament is one of the most frequently injured ligaments of the knee [10, 19, 24]. The incidence of these injuries has been reported to be as high as 0.24 per 1000 in the United States in any given year [4]. The mechanism of injury involves a valgus stress with usually a combined external tibial rotation component from either noncontact (pivoting or cutting) or a contact injury (direct blow to the lateral side of the knee) in slight knee flexion [24]. The majority of the medial collateral ligament tears are isolated. Studies have reported that most of the lesions are located near the femoral insertion site [14, 16].

Historically, the treatment of acute medial collateral ligament injuries has mainly focused on conservative measures, showing good outcomes. More recently, the repair and reconstruction of more severe acute grade III and symptomatic chronic medial collateral ligament injuries has gained interest [3, 25]. The concept of ligament isometry has been at the heart of models that describe normal knee motion and is crucial for anatomic superficial medial collateral ligament (sMCL) reconstruction techniques [6, 22]. The sMCL is an isometric ligament in its central fibers although previous work showed a different behaviour described between the anterior and posterior part of the sMCL [2, 23]. A ligament is generally considered isometric when the change in length and thus the strain in the whole ligament during the arc of motion is less than 2% [9, 22]. Whether a 2% change in length should be considered minimal is a question that can be raised as studies have shown that damage accumulation in the collagen fibers may already start at 4 or 5% of strain [18]. Moreover, at the sub-regional level, a different situation may exist because biological tissue is inhomogeneous, non-linear and anisotropic. Strain propagation and distribution in the ligament may therefore show important regional variation. Previous studies have reported significant differences in forces and strains between the proximal versus the distal part and the anterior versus the posterior part of the sMCL [2, 8, 23]. However, in most studies, the forces defining different regions were very rough and the strain measurement techniques lacked resolution and accuracy [2, 8]. The strain gauges that were used require an amount of dissection for their insertion and require some form of fixation to the tissue thereby potentially introducing measurement errors [20]. Moreover, they act as point gauges and thus fail to show regional strain patterns. In this study, 3D digital image correlation (DIC) was therefore adopted to investigate the strain distribution in the sMCL of the knee.

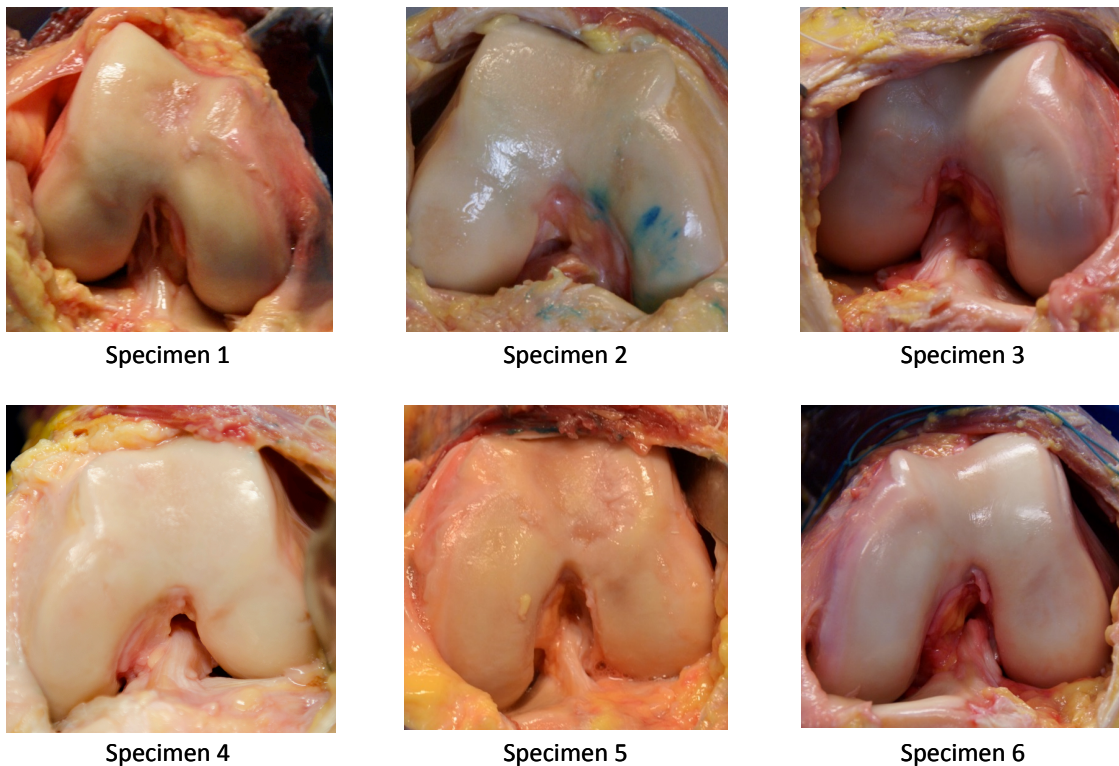
The purpose of the study was to describe the strain distribution in the sMCL of the knee during loaded knee motion by creating a high-resolution 3D strain map and to analyse sub-regional strain differences. It was hypothesised that the sMCL would behave isometrically (< 2% strain variation) and that the sub-regional strain would inhomogeneously distributed over its surface.

## MATERIALS AND METHODS

Six paired fresh frozen lower limbs, disarticulated at the level of the hip, were obtained from two male and one female human donors after approval of the study protocol by Ethics committee. The donors were between 48 and 70 years of age when they died. The specimens were stored at -22°C prior to the experiment. The demographic variables of the specimens are given in table 1.

Donor nr	Sex	Age	Weight (kg)
Donor A	Male	48	64
Donor B	Male	69	90
Donor C	Female	70	40

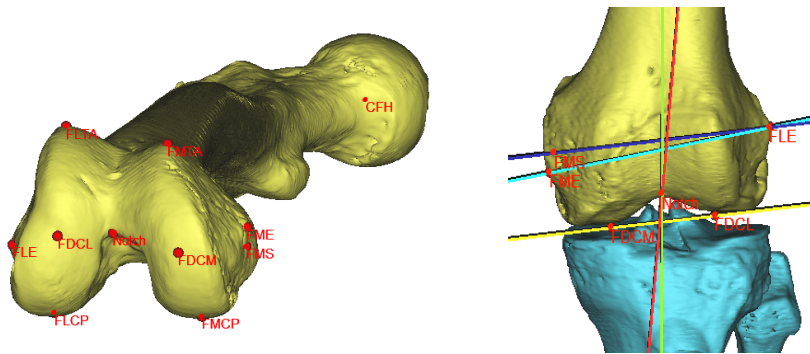
**Table 1:** Demographic data of the specimens



**Figure 1:** Photographs of each specimen after arthrotomy. The integrity of the knee was confirmed.

For all 6 knee specimens, CT images were obtained with a volumetric CT scanner (Toshiba Medical Systems, Otawara, Japan). The slice thickness was 0.5 mm, the image matrix was 512 × 512 pixels and the pixel size was 0.625 mm. The CT scans were performed with the specimens in the frozen state to preserve the quality of the specimens. Each knee was assessed for abnormalities. Exclusion criteria were: previous surgery on the knee, previous trauma of the cruciate ligaments or significant

osteo-arthritis. One specimen had a degenerative medial meniscal tear with a parameniscal cyst. However, the integrity of the sMCL was not compromised. All CT scans were uploaded in a 3-dimensional visualisation software system (Mimics 14.12, Materialise, Haasrode, Belgium) for further analysis. After a bone surface reconstruction mask was created, all relevant surface landmarks and ligament insertion sites on the medial side of the knee were identified based on the quantitative description of LaPrade [18] and Victor [25] (fig 2). These data were combined with the 3D-DIC data to add surface anatomy to the analysis.

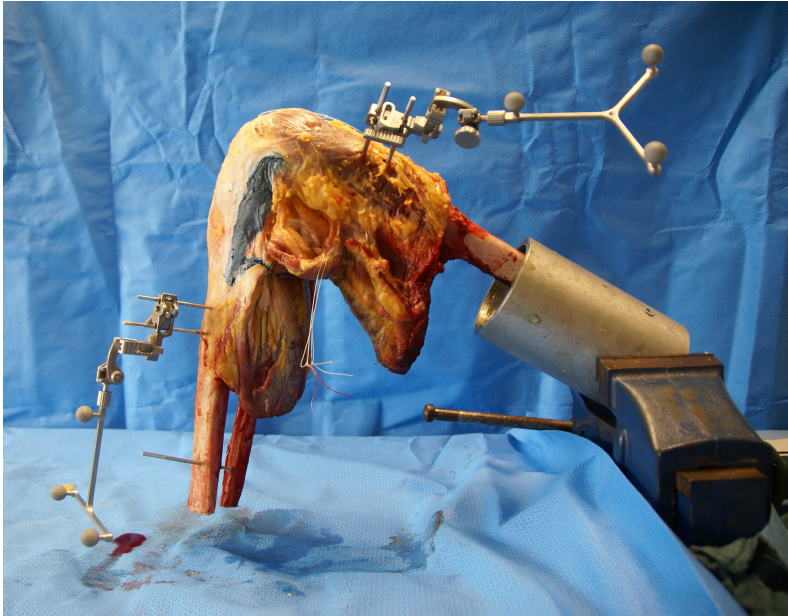


**Figure 2:** 3D surface mask reconstruction of the knee. All osseous landmarks, axes and planes of interest were analysed.

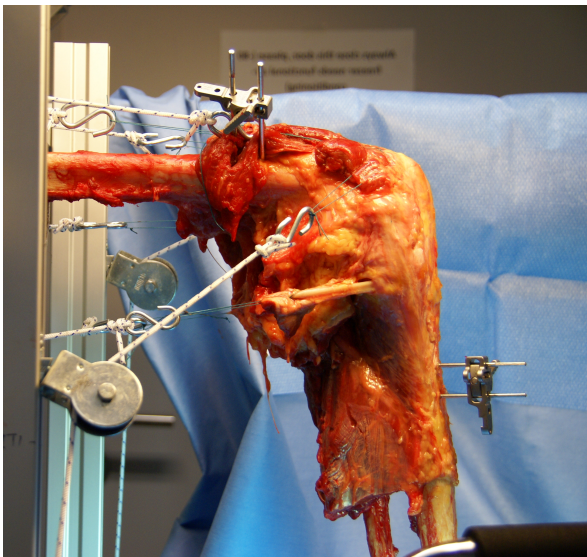
Prior to dissection, the specimens were thawed overnight for 17h - 20h at a room temperature of 20° C and prepared by resecting the skin and subcutaneous fat. Meticulous prevention of drying out of the specimen was done throughout the experiment using wet towels and water spraying.

Next, an anterior midline incision was made, followed by a standard subvastus arthrotomy. A clinical picture of each knee after subvastus arthrotomy is shown in figure 1. Two pins for the navigation frames were respectively placed in the distal femur and proximal tibia according to the manufacturer's recommendations. The position of the femoral pins was chosen in order to avoid interference with the closure of the joint capsule and with the extensor mechanism. Bone morphing acquisitions of the femur and tibia, including the centre of the hip and ankle, were performed with the use of the navigation system (Brainlab, Feldkirchen, Germany). Resection of the anterior horn of the medial and lateral meniscus was necessary to be able to reach the joint surfaces. The knee capsule was then anatomically closed. The femur was severed 35 cm proximal to the knee joint line. 20 cm of bone was cleared from soft tissue for embedding. The tibia was severed 28 cm distal to the knee joint line and the bone 5 cm distally to the distal tibial sMCL insertion site was cleared from all soft tissues. The femur was rigidly fixed in a cylindrical container using a polyester resin (fig 3).

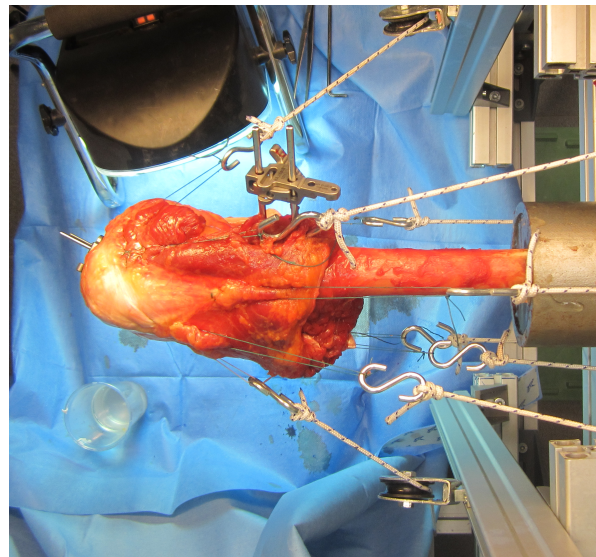




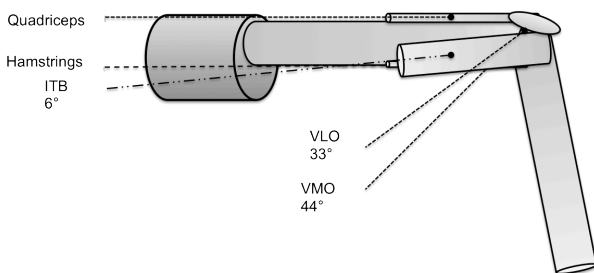
**Figure 3:** Typical example of the specimen after preparation with the navigation frames in place. The sMCL is dyed dark blue by the methylene blue.



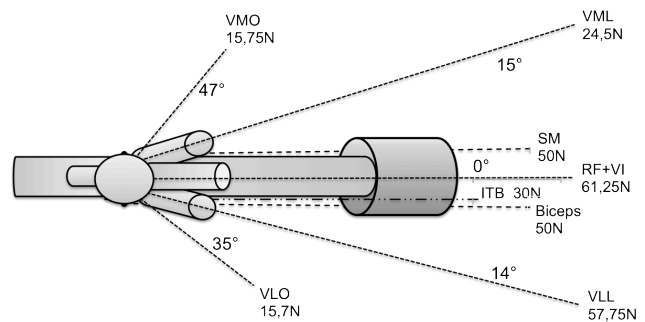
A.



B.



C.



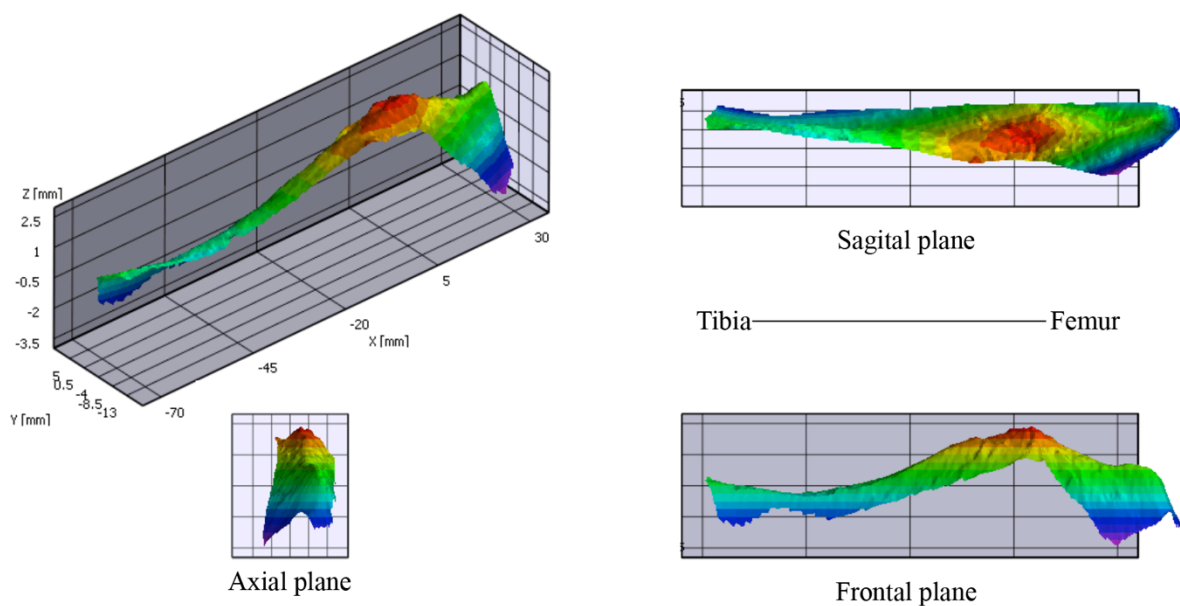
D.

**Figure 4:** In vivo (a, b) and schematic representation (c, d) the knee mounted in the knee rig seen from the top (b, d) and seen from the side (a, c). Each muscle unit around the knee was loaded with a predefined force in a controlled direction.



Subsequently, the sMCL was prepared. The sartorius, semitendinosus, and gracilis tendons were removed from their attachment sites to allow adequate visualization of the distal sMCL. The proximal and distal insertion sites of the sMCL were identified according to the quantitative anatomical description by LaPrade [15]. The sMCL was left untouched in its native bed. All muscle attachment sites of the different parts of the quadriceps (vastus medialis obliquus (VMO), vastus medialis longus (VML), vastus intermedius (VI), rectus femoris (RF), vastus lateralis longus (VLL) and vastus lateralis obliquus (VLO)), the semimembranosus (SM), the biceps femoris and the iliotibial band (ITB) were located and an Ethibond 2 suture (Ethicon, Johnson and Johnson, Somerville, New Jersey) loop was attached to these muscles to provide an anchor for applying load in the knee rig.

The construct was then mounted in a custom made knee rig based on the work of Amis et al. (fig 3) [1]. The set-up consisted of a framework in which the cylindrical container of the femur was rigidly fixed. The tibia was left unconstrained, allowing six degrees of freedom in the knee. A total load of 175 N was proportionately divided over the different parts of the quadriceps muscle, 30 N was applied to the iliotibial band (ITB) and 50 N to the medial and lateral hamstrings (fig 4). The load was applied according to the cross-sectional areas of each muscle unit, based on the work of Farahmand et al. and Victor et al [5, 21]. The load was applied in physiological directions of each muscle by attaching a series of calibrated weights. The direction of the traction cables in the three planes was controlled using a digital inclinometer for each specimen. As a result, a statically balanced muscle loading of the knee was obtained.

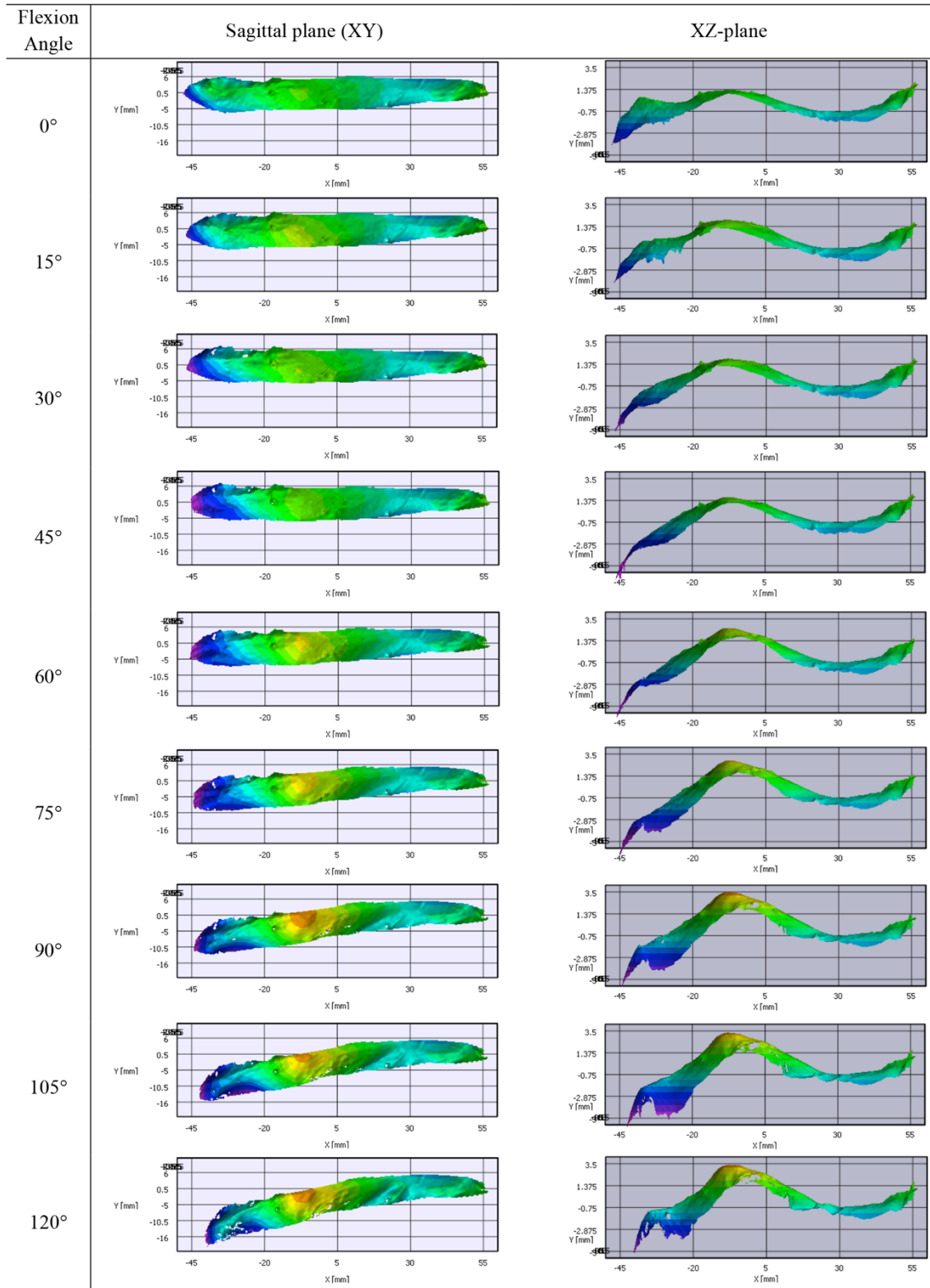


**Figure 5:** 3D morphology of the sMCL at rest position (approx. 6° flexion) showing the Z-coordinate in the colour scale (specimen 3). XY- plane = sagittal plane; XZ-plane = frontal plane; YZ-plane = axial plane

Starting from a neutral position with all loads attached, the knee was first brought from the neutral position (on average 6° of flexion) to full extension (0°). Subsequently, the knee was flexed up to 120° at 15° intervals. The deformation of the sMCL during this movement was recorded with a 3-dimensional Digital image correlation (DIC) system (Limess GmbH, Pforzheim, Germany). The experimental setup consisted of two charge-coupled device (CCD) cameras with a resolution of 2486 x 1985 pixels. At each flexion angle, these cameras captured three images of the sMCL. To obtain an optimal contrasted image, the sMCL was prepared with a modified technique as described in the previous chapter [17]. This implied the application of random white speckle pattern using a water-based white paint in a spray can on the sMCL that was first dyed dark blue with the use of methylene blue. A dedicated software package (VIC3D, Correlated Solutions Inc., Columbia, USA) was used to analyse the deformation and strain at each flexion angle using the camera images. Both the overall strains in the ligament as well as the regional strains can be measured with the system. A previously reported accuracy analysis showed a low scatter (0.03%) and a high spatial resolution of 0.1 mm<sup>2</sup> for strain measurement on the Achilles tendon [17]. Using the same methodology as in the previous chapter, it was concluded that the scatter was low for all specimens; in the centre of the specimens values ≤ 0.2 % were obtained, based on a 95% confidence interval and assuming a normal distribution. It is noted that the standard deviation of the strains in the specimen is of the same order of magnitude as for the analysed areas located on the steel blocks. The spatial resolution was calculated to be 0.1 mm<sup>2</sup>. From the full field measurements, the strain was evaluated at every tracked point of the sMCL. The longitudinal strain was defined as the strain along the longitudinal axis of the sMCL, from femoral till distal tibial insertion site. Transverse strain was the strain along an axis perpendicular to the longitudinal axis. And shear strain was strain along an axis angulated at 45° to the longitudinal and transverse axis.

In one specimen, the quality of the speckle pattern was insufficient to perform the detailed analysis and it was subsequently excluded from further analysis.

For the subdivision in the different regions of the sMCL (proximal vs middle vs distal), the CT data and the quantitative description of LaPrade were utilised [15]. The distance from the medial epicondyle to the joint line was determined for each specimen. The proximal region was defined as the region from the femoral insertion site till 1 cm above the joint line. The middle region was outlined as the region from 1 cm above the joint line till 1.5 cm below. And the distal region was the region from 1.5 cm distal from the joint line till the distal tibial insertion site 6 cm below the joint line [15].



**Figure 6:** Typical example of the deformation analysis of the sMCL in the frontal (XZ) and sagittal (XY) plane through the range of motion. The colour scale indicates the Z-coordinate.

*Deformation analysis:*

From the deformation analysis in the sagittal plane, it was observed that at 60° of flexion, the sMCL was no longer a rectangular bar (fig 6). A kink was observed at the proximal tibial plateau. The location of this kink was plotted on the pre-operative CT scan using Mimics 14.12 (Materialise, Haasrode, Belgium). To quantitatively evaluate this rotation for all specimens, the deformation of an initial straight line was therefore monitored and, using a least square fit, approximated by a bi-linear fit. The angle between both linear parts of this curve fit, denoted as  $\alpha$ , was subsequently calculated.

*Cumulative strain distribution:*

To overcome the practical issues with the analysis of the data due to the local heterogeneity of the different strain maps, a cumulative strain distribution was created. To that extent, the analysed area was subdivided in squares of 1 x 1 mm and the strain was evaluated at the centre of each square. Subsequently, a cumulative distribution for the whole tendon was calculated from each frame. A typical example of the cumulative strain distribution is shown in figure 11. The X-axis represents the percentage of the surface area of sMCL. The Y-axis represents strain. In this way, the relative surface area showing a strain of less than and equal to a certain strain is plotted. E.g. for specimen 6, at 45° of flexion, 80% of the surface area of the sMCL showed a strain of less than or equal to 0%. The area under the curve represents a measure for the strain accumulated over the entire surface of the sMCL at a certain flexion angle.

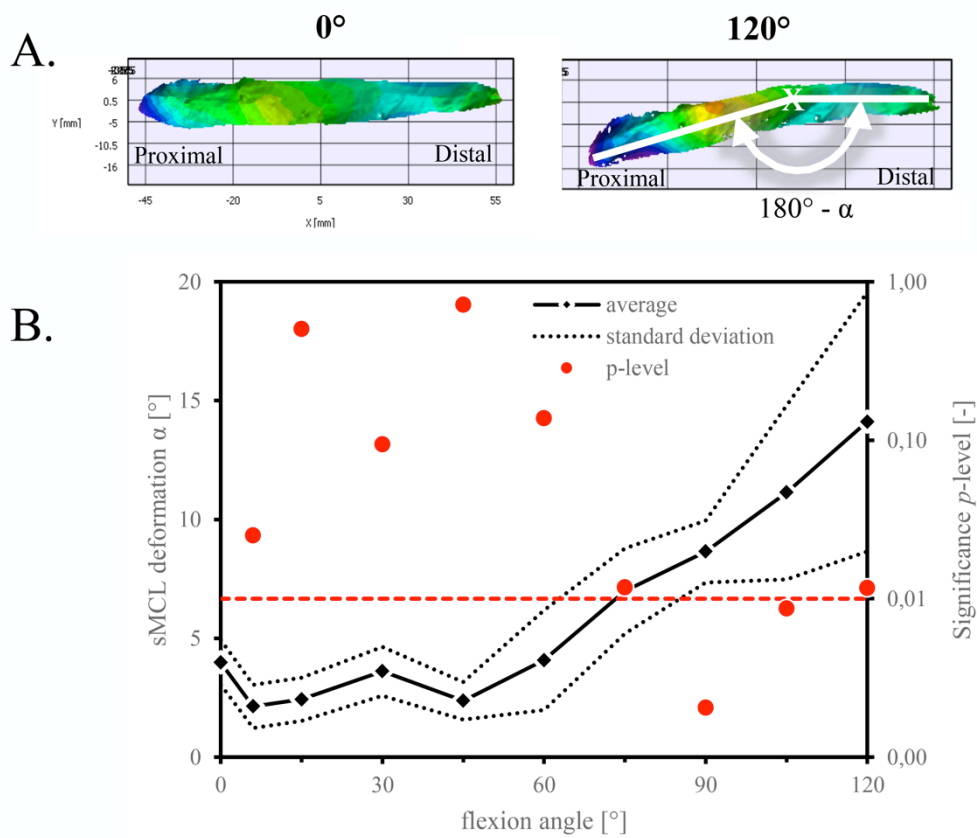
*Statistical analysis*

The results were analysed using Student's paired t-test. The significance level was set at  $p < 0.05$ . All analyses have been performed using SAS software, version 9.2 of the SAS System for Windows (SAS Institute Inc., Cary, NC, USA).

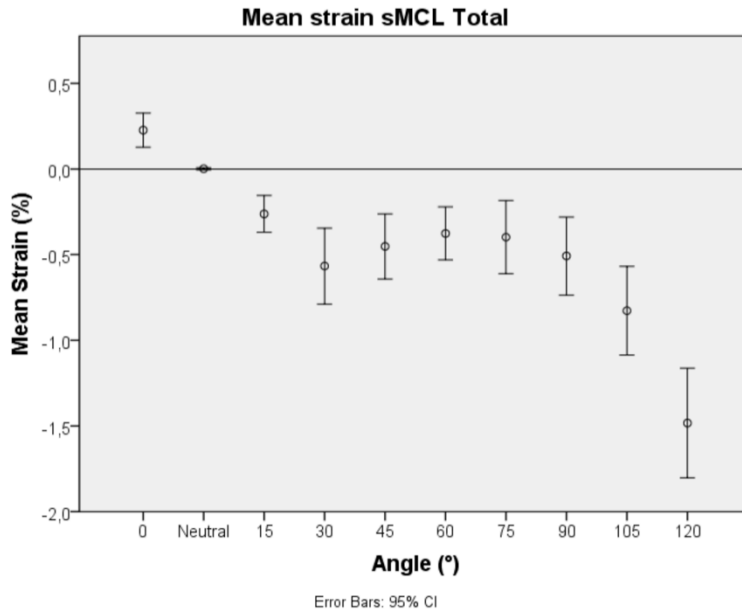
**RESULTS***Morphology and deformation analysis*

The total length as measured from proximal to distal attachment and width of the sMCL as calculated from the 3D DIC analysis was on average 104.1 mm (SD 15.2) and 17.28 mm (SD 3.3) respectively. The three-dimensional morphology of the sMCL was analysed with the use of 3D DIC. A characteristic 3D morphology image of the sMCL in extension is shown in figure 5. In the sagittal plane, an S-shaped morphology was observed. During knee flexion, the sMCL did not behave as a rigid bar but was

deformed in the 3 planes. Most deformation occurred in the frontal (XZ) and sagittal (XY) plane (fig 6). In the sagittal plane, this deformation was observed at larger flexion angles (beyond 60°) and could be described as a rotation of the proximal part of the sMCL relative to the distal part with the center of this rotation being the proximal tibial insertion site of the sMCL. The angle between both linear parts of a curve fit was denoted as  $\alpha$ . On average, the deformation angle remained close to zero up to a flexion angle of 60 degrees (fig 7). Beyond this flexion angle, a significant increase of the deformation angle was observed, which averaged 14° in deep flexion (fig 7) ( $p < 0.05$ ).



**Figure 7:** A view on the sMCL in the sagittal plane at 0° and 120° of knee flexion (A). At 0°, the sMCL was a rectangular bar. During knee flexion, this bar is progressively deformed. The deformation can be described as a rotation around the point X. This point was located at the proximal tibial insertion site of the sMCL. The inclination angle  $\alpha$  as function of the flexion angle is shown in (B). A statistically significant deformation occurred at flexion angles of more than 60°.

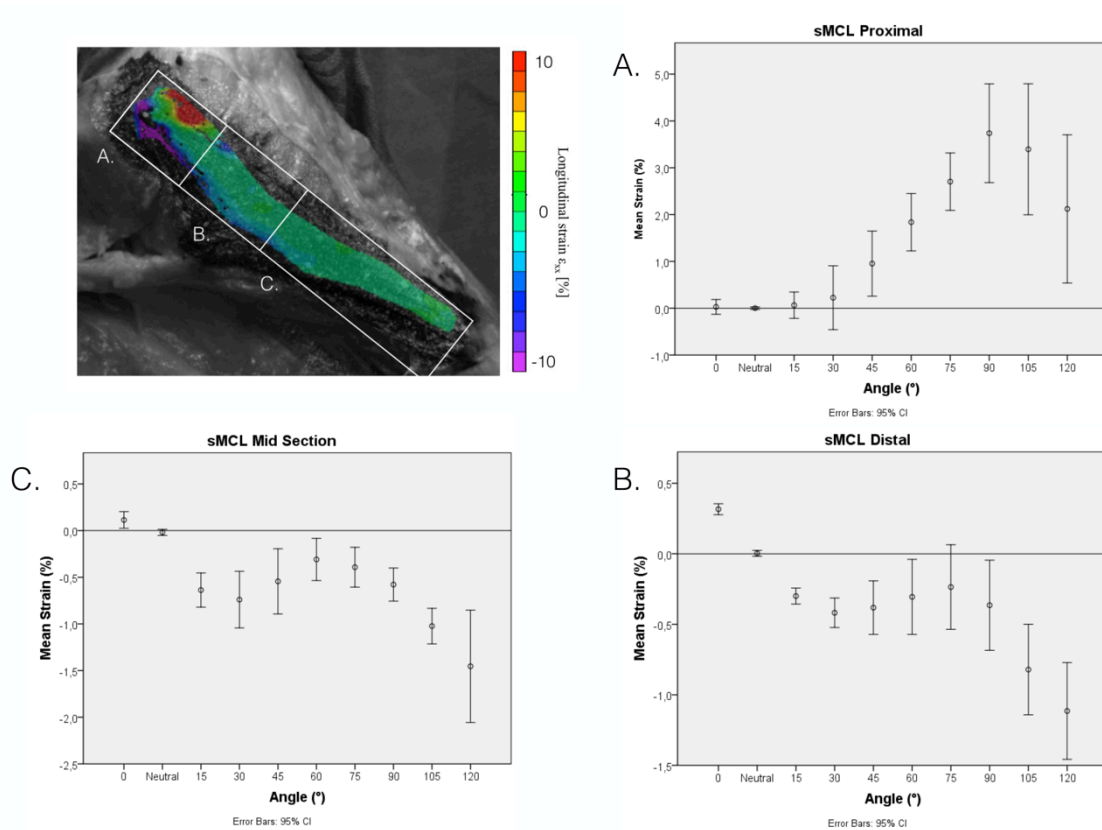


**Figure 8:** Longitudinal strain in the central part of the sMCL from proximal femoral to distal tibial insertion site during the range of motion for all 5 specimens. Means are represented with a 95% confidence interval.

Also in the frontal plane a significant deformation was observed. Here, within the proximal part, a significant medialisation of the proximal tibial attachment site relative to the femoral attachment site was observed with increasing flexion (fig 6). When the 3D DIC surface map was projected on the CT reconstruction images, the most medial point in the frontal plane (maximum z-coordinate) coincided with the course of the sMCL over the proximal tibia just distal to the joint line.

#### *Strain analysis*

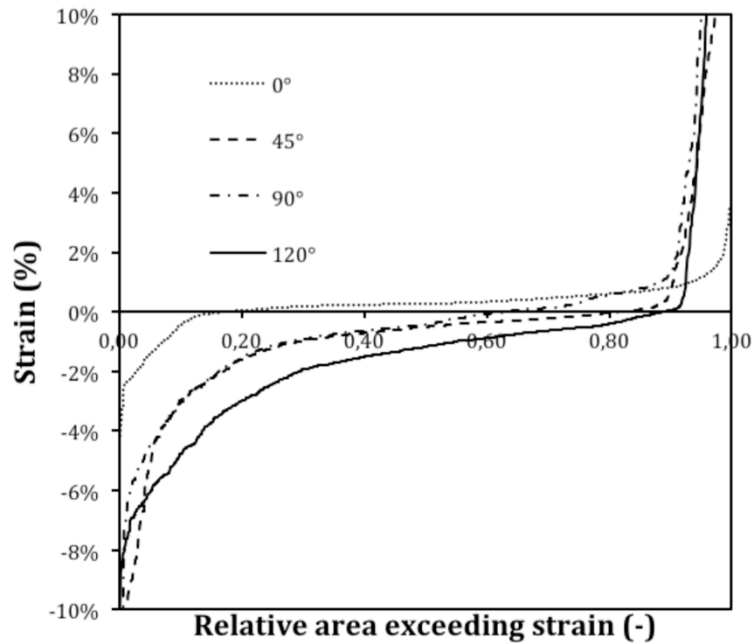
First, the longitudinal strain in the central part of the whole sMCL from femoral to distal tibial attachment was analysed (fig 8). A typical example of a 3D strain map of the sMCL is shown in the supplementary material. From full extension to 30° of flexion, a slackening of on average -0.8% was observed with progressive knee flexion. Between 15° and 90° of knee flexion, the average strain variation remained below 0.3%. In deep flexion (90° to 120°), a further slackening of the sMCL of on average -1.0% was seen until a total slackening of on average -1.5% was seen compared to the neutral position. During the whole range of motion, the maximum change in length of the sMCL was on average 1.7%.



**Figure 9:** Regional (A proximal, B: middle, C: distal) strain distribution in the sMCL according to the flexion angle for the 5 specimens. The mean values are represented with the 95% confidence interval. Positive values indicate lengthening, negative values shortening. Significantly higher strains are noted in the proximal region.

Next, a subdivision of the sMCL in 3 regions was created (fig c) and the longitudinal strain in each region was analysed. Significant regional inhomogeneity was observed. The strain in the proximal part of the sMCL (region A) was significantly different from the strain in the middle (region B) and the distal portion (region C) at any point from 15° to 120° of knee flexion (fig 9) ( $p < 0.05$ ). The highest strains (average 3.7%, SD 1.5) were seen in this proximal part of the sMCL at 90° of flexion. The strain in the middle and distal part were not significantly different from each other or from the strain in the central part sMCL.

For all specimens, the strain accumulated over the entire surface of the sMCL was the highest at full extension. The accumulated strain gradually decreased with knee flexion and was the lowest in deep flexion (fig 8).



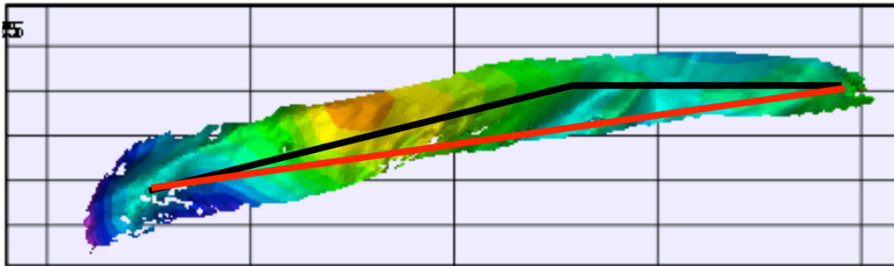
**Figure 10:** Cumulative strain distribution of the sMCL at different flexion angles in specimen 6.

## DISCUSSION

The most important finding from this study was that the sMCL did not behave as a homogeneous rigid bar but was deformed in the three planes during the range of motion. As a result, the strain in the proximal part of the sMCL was significantly different from the strain in the middle and distal portion. LaPrade et al. recently described the sMCL and its insertion sites in a detailed quantitative way [15]. The quantitative description of the insertion sites of the ligament opened the door for a better biomechanical understanding of the ligament's function. This knowledge is crucial for sMCL repair and reconstruction techniques. From an anatomical point of view, the sMCL was long considered to be a rectangular homogenous structure. This conventional anatomical description is two-dimensional and only situated in the sagittal plane. The current study adds a new perspective to the understanding of the anatomy of the sMCL by defining the anatomy in the 3D space and analysing it during knee motion. Apart from the rectangular appearance in the sagittal plane, it was found that a rather S-shaped morphology defines the sMCL in the coronal plane. Furthermore, it was found that in both the sagittal and frontal plane, significant deformation of the sMCL occurred with knee flexion. The sMCL can therefore no longer be looked at as a rigid rectangular bar. The most important deformation was found in the sagittal plane where a rotation of the distal part of the sMCL relative to the proximal part occurred with the centre of rotation being the proximal tibial sMCL



insertion site. This finding is of critical importance for sMCL reconstruction techniques. Only fixing the graft at the distal tibial insertion site but not at the proximal tibial location could cause laxity in flexion. This is a consequence of the fact that the femoral and distal tibial insertion sites approach each other with increasing knee flexion (fig 11). Reconstruction of the proximal tibial insertion site of the sMCL is therefore crucial to maintain its isometry and thus stability throughout the whole range of motion [3, 25].



**Figure 11:** The distance between the femoral and distal tibial insertion site of the sMCL (in red) is smaller in flexion than in extension as both insertion sites approach each other. Only fixing the graft at the distal insertion site on the tibia but not on the proximal tibial location would therefore cause laxity in flexion.

The second most important finding of this study was that the strain in the sMCL was inhomogeneously distributed over its surface with the strain in the proximal part near the sMCL insertion site being the highest. This observation can be directly related to the in vivo failure pattern of the sMCL. Tears of the sMCL are most frequently found near the femoral insertion site. They occur with the knee in slight flexion. At full extension, 57% of the restraint against valgus force is provided by the MCL [11]. The posterior oblique ligament (POL), ACL, and posteromedial capsule are responsible for the majority of the remaining restraint. At 25° of knee flexion however, 78% of the restraint against valgus is provided by the MCL, making it more vulnerable for injury [11]. At this flexion angle, the strain in the proximal part of the sMCL was significantly higher than in the other parts (fig 9). Due to this 'preload' strain in the proximal part, a pathologic elongation caused by an external valgus force is more likely to cross the damage threshold first in this region and cause structural defects.

A possible explanation for the higher strains in this region can be found in the fact that the centre of rotation of the knee in the femur coincides with the insertion site on the sMCL on the femur [13]. As the femoral insertion site of the sMCL is not a point but a surface area of on average 94.1mm<sup>2</sup>, part of the sMCL fibers at the insertion site will be located anteriorly to the axis of rotation and part of the fibers posteriorly to it [15]. This implies a sort of wrapping around the axis of rotation of the proximal sMCL fibers when the knee is flexed [23]. This will cause elongation of the anterior fibers and slackening of the posterior ones. This hypothesis was confirmed by our findings showing high strains

in the anterior proximal part of the sMCL with progressive knee flexion and lower strains in the posterior proximal part. Previous studies failed to detect these differences because of a low spatial resolution of the used measurement method or investigation of only a part of the sMCL. As the surface area of the proximal part is relatively small, its effect on the total strain is small and is easily missed.

This regional strain being significantly different from the overall strain was suggested by other studies although the spatial resolution of the measurement methods was fairly low and did not allow for regional strain analysis [2]. The inhomogeneous, non-linear and anisotropic nature of biological tissue explains part of this observation. From a pathogenetic point of view, the sMCL therefore cannot be thought of as a single homogenous unit. In our study, local strains stayed local and were not propagated across the whole ligament. Several factors might explain this observation. The bone geometry was one factor. As demonstrated in figure 1, the sMCL is not a linear structure. The shape of the distal femur, the medial epicondyle and the proximal tibial plateau determine the 3D surface morphology of the sMCL, which displayed important variability in the 3 planes. Knee motion will therefore affect the different parts of the sMCL differently. Second, from a biologic point of view, a ligament is known to be an inhomogeneous structure, which can show important regional variation in collagen bundle branching, fiber size and the amount of ground substance. These factors all affect local stiffness and strain. Third, interactions with the posterior oblique ligament are likely to affect the proximal and distal part of the sMCL differently because the fiber orientation is different in those parts. One of the advantages of our study is that no dissection of the sMCL was performed. The ligament was left untouched in its native bed, thereby preserving any existing connection with surrounding structures and thus mimicking the in vivo situation. Finally, tibiofemoral motion, both rotational and translational might affect the different parts of the sMCL differently.

A third important finding of this study was that, from a biomechanical point of view, the sMCL was confirmed to be an isometric ligament. According to the existing literature, a ligament is considered isometric when the strain is less than 2% during the range of motion [9, 22]. Our data confirm these findings but with greater accuracy. When considered in its central portion between 15° and 90° of knee flexion, the strain in the sMCL fibers remained below 0.3%. Therefore, the central fibers of the sMCL did indeed prove to be near perfectly isometric, with no change in length during the range of motion. This finding is important for sMCL reconstruction techniques. Only a perfect anatomic restoration of the insertion sites of the sMCL on the femur and tibia will be able to reproduce this isometry and thus provide the adequate stability throughout the range of motion. Even small deviations will cause an anisometric graft with ligament laxity or elongation with knee flexion, depending on the position of the graft relative to the anatomic insertion site [6, 7].

Our study has several limitations. First one is the fact that only 5 specimens were available for analysis after exclusion of 1 specimen due to poor speckle tracking quality. However, the high resolution and accuracy of the measurement technique allowed us to draw statistically significant conclusions. A second limitation was the fact that the knee was loaded in a static way. Further research is needed to enable extrapolation of these data to the dynamic in vivo situation. A third limitation was the fact that the analysis is limited to the properties of the superficial layer of a tissue sample. However, our data are consistent with previous studies using invasive measurement methods [2, 8, 12].

## CONCLUSION

The sMCL can be considered as a perfect isometric ligament between 15° to 90° of knee flexion. However, significant regional inhomogeneity in strain exists and significant deformation in the three planes was observed. The highest strains were seen near the femoral insertion site. These higher baseline strains might explain why most of the sMCL lesions are seen in this region.

## REFERENCES

1. Amis AA, Oguz C, Bull a MJ, Senavongse W, Dejour D (2008) The effect of trochleoplasty on patellar stability and kinematics: a biomechanical study in vitro. *J. Bone Joint Surg. Br.* 90:864–9
2. Arms S, Boyle J, Johnson R, Pope M (1983) Strain measurement in the medial collateral ligament of the human knee: an autopsy study. *J. Biomech.* 16:491–6
3. Coobs BR, Wijdicks C a, Armitage BM, Spiridonov SI, Westerhaus BD, Johansen S, Engebretsen L, Laprade RF (2010) An in vitro analysis of an anatomical medial knee reconstruction. *Am. J. Sports Med.* 38:339–47
4. Daniel D, Pedowitz R, O’connor J, Akeson W (2003) Daniel’s knee injuries: ligament and cartilage structure, function, injury and repair. Lippincott Williams and Wilkins, Philadelphia
5. Farahmand F, Senavongse W, Amis AA (1998) Quantitative study of the quadriceps muscles and trochlear groove geometry related to instability of the patellofemoral joint. *J. Orthop. Res.* 16:136–43
6. Feeley BT, Muller MS, Allen A a, Granchi CC, Pearle AD (2009) Biomechanical comparison of medial collateral ligament reconstructions using computer-assisted navigation. *Am. J. Sports Med.* 37:1123–30
7. Feeley BT, Muller MS, Allen A a, Granchi CC, Pearle AD (2009) Isometry of medial collateral ligament reconstruction. *Knee Surg. Sports Traumatol. Arthrosc.* 17:1078–82
8. Gardiner JC, Weiss J a, Rosenberg TD (2001) Strain in the human medial collateral ligament during valgus loading of the knee. *Clin. Orthop. Relat. Res.* 266–74
9. Ghosh KM, Merican AM, Iranpour F, Deehan DJ, Amis A a (2012) Length-change patterns of the collateral ligaments after total knee arthroplasty. *Knee Surg. Sports Traumatol. Arthrosc.* 20:1349–56

10. Griffith CJ, LaPrade RF, Johansen S, Armitage B, Wijdicks C, Engebretsen L (2009) Medial knee injury: Part 1, static function of the individual components of the main medial knee structures. *Am. J. Sports Med.* 37:1762–70
11. Grood E, Noyes F, Butler D, Suntay W (1981) Ligamentous and capsular restraints preventing straight medial and lateral laxity in intact human cadaver knees. *J. Bone Joint Surg. Am.* 63:1257
12. Harfe DT, Chuinard CR, Espinoza LM, Thomas K a, Solomonow M (1998) Elongation patterns of the collateral ligaments of the human knee. *Clin. Biomech. (Bristol, Avon)* 13:163–175
13. Hollister AM, Jatana S, Singh AK, Sullivan WW, Lupichuk AG (1993) The axes of rotation of the knee. *Clin Orthop Relat Res* 259–268
14. Kawada T, Abe T, Yamamoto K, Hirokawa S, Soejima T, Tanaka N, Inoue a (1999) Analysis of strain distribution in the medial collateral ligament using a photoelastic coating method. *Med. Eng. Phys.* 21:279–91
15. LaPrade RF, Engebretsen AH, Ly T V, Johansen S, Wentorf F a, Engebretsen L (2007) The anatomy of the medial part of the knee. *J. Bone Joint Surg. Am.* 89:2000–10
16. Lee JI, Song IS, Jung YB, Kim YG, Wang CH, Yu H, Kim YS, Kim KS, Pope TL (1996) Medial collateral ligament injuries of the knee: ultrasonographic findings. *J. ultrasound Med. Am inst Ultrasound Med* 15:621–625
17. Luyckx T, Verstraete M, De Roo K, De Waele W, Bellemans J, Victor J (2014) Digital image correlation as a tool for three-dimensional strain analysis in human tendon tissue. *J. Exp. Orthop.* 1:7
18. Maffulli N (1999) Current Concepts Review-Rupture of the Achilles Tendon. *J. Bone Jt. Surg.* 81:1019–36
19. Miyasaka KC, Daniel DM, Stone ML, Hirshman P (1991) The incidence of knee ligament injuries in the general population. *Am J Knee Surg* 4:3–8
20. Ravary B, Pourcelot P, Bortolussi C, Konieczka S, Crevier-Denoix N (2004) Strain and force transducers used in human and veterinary tendon and ligament biomechanical studies. *Clin. Biomech. (Bristol, Avon)* 19:433–47
21. Victor J, Labey L, Wong P, Innocenti B, Bellemans J (2010) The influence of muscle load on tibiofemoral knee kinematics. *J. Orthop. Res.* 28:419–28
22. Victor J, Wong P, Witvrouw E, Sloten J Vander, Bellemans J (2009) How isometric are the medial patellofemoral, superficial medial collateral, and lateral collateral ligaments of the knee? *Am. J. Sports Med.* 37:2028–36
23. Warren LA, Marshall JL, Girgis F (1974) The prime static stabilizer of the medical side of the knee. *J. Bone Joint Surg. Am.* 56:665–74
24. Wijdicks C a, Griffith CJ, Johansen S, Engebretsen L, LaPrade RF (2010) Injuries to the medial collateral ligament and associated medial structures of the knee. *J. Bone Joint Surg. Am.* 92:1266–80
25. Wijdicks C a, Michalski MP, Rasmussen MT, Goldsmith MT, Kennedy NI, Lind M, Engebretsen L, LaPrade RF (2013) Superficial medial collateral ligament anatomic augmented repair versus anatomic reconstruction: an in vitro biomechanical analysis. *Am. J. Sports Med.* 41:2858–66

### **3.2.2 THE EFFECT OF JOINT LINE ELEVATION ON STRAIN IN THE MEDIAL COLLATERAL LIGAMENT**

**T Luyckx, K De Roo, M Verstraete, J Victor**

Raising the joint line in TKA significantly increases strain the medial collateral ligament.

*Manuscript prepared for submission to the Bone and Joint Journal*

#### **ABSTRACT**

##### **Background**

Joint line elevation is frequently encountered during TKA. Its effect on strain in the soft tissue envelope of the knee remains poorly understood.

##### **Methods**

Five fresh frozen knee specimens were mounted in a custom made rig. The strain in the superficial medial collateral ligament (sMCL) during the range of motion was measured using digital image correlation. The experiment was repeated after computer-navigated implantation of a TKA with restoration of the medial joint line (TKA0) and with a 4 mm proximalised joint line (TKA4).

##### **Results**

In the native knee, the sMCL was almost perfectly isometric between 15° and 90° of knee flexion. After TKA (TKA0), the strain in the sMCL in deeper flexion (90° to 120°) was significantly higher compared to the native knee. The increase was maximal at 120° where the difference averaged 2.5% stain.

After raising the distal and posterior joint line (TKA4), the strain in the sMCL from 0° to 90° was comparable with the TKA0 position. In deeper flexion (90° to 120°) a further significant increase in sMCL strain was observed. The increase was maximal at 120° and the difference averaged 3.5% stain compared with the native knee..

TKA implantation and joint line elevation caused a significant decrease in maximal passive knee flexion (133° vs 122° vs 105°).

##### **Conclusion**

TKA significantly increased the strain in the sMCL in flexion despite a well-balanced flexion and extension gap. Joint line elevation caused further elongation of the sMCL. These higher sMCL strains

might hinder knee flexion. Aiming at equal tension on the flexion and extension gap might therefore compromise deep flexion in TKA.

## INTRODUCTION

Joint line changes seem to be inherent to knee replacement surgery. More specific, joint line elevation in the coronal plane is very frequently observed [6, 11, 17, 21]. This is partially due to the fact that the surgeon uses a worn out distal femoral surface as a reference. The lack of compensation for this distal femoral wear will inadvertently raise the joint line a few millimetres. Secondly, in case of a fixed flexion contracture, many surgeons will deliberately raise the joint line to increase the extension gap and obtain full extension [4]. In a posterior stabilised (PS) total knee arthroplasty (TKA), this tendency is even stronger as cutting the posterior cruciate ligament (PCL) will increase the flexion space. Obtaining a balanced flexion and extension space can thus often only be obtained by raising the joint line a few millimetres. Joint line proximalisation is therefore embedded in almost all TKA instrumentation systems.

The effect of this joint line proximalisation on coronal plane stability and strain in the superficial medial collateral ligament (sMCL) is not well understood. Many surgeons believe that as long as a balanced flexion and extension gap are obtained, coronal plane stability will be restored. However, there is some evidence that joint line proximalisation might induce mid-flexion instability, despite a well-balanced flexion and extension gap [7, 20]. Coronal plane stability is mainly provided by the collateral ligaments and joint line elevation might have an important effect on the tension and strain in these ligaments. The medial collateral ligament is generally accepted to be an isometric ligament showing less than 2% of change in length through the range of motion (ROM) [25]. The importance of restoring the anatomic femoral insertion site of the sMCL to maintain its isometry and obtain joint stability is well known in sMCL reconstruction techniques [13]. In TKA, joint line elevation is very likely to change the original centre of rotation of the knee and therefore affect the sMCL isometry.

The purpose of this study was therefore to:

1. Investigate the effect of single radius TKA implantation with restoration of the medial joint line level on the strain in the sMCL;
2. Investigate the effect of joint elevation on strain in the sMCL of the knee;

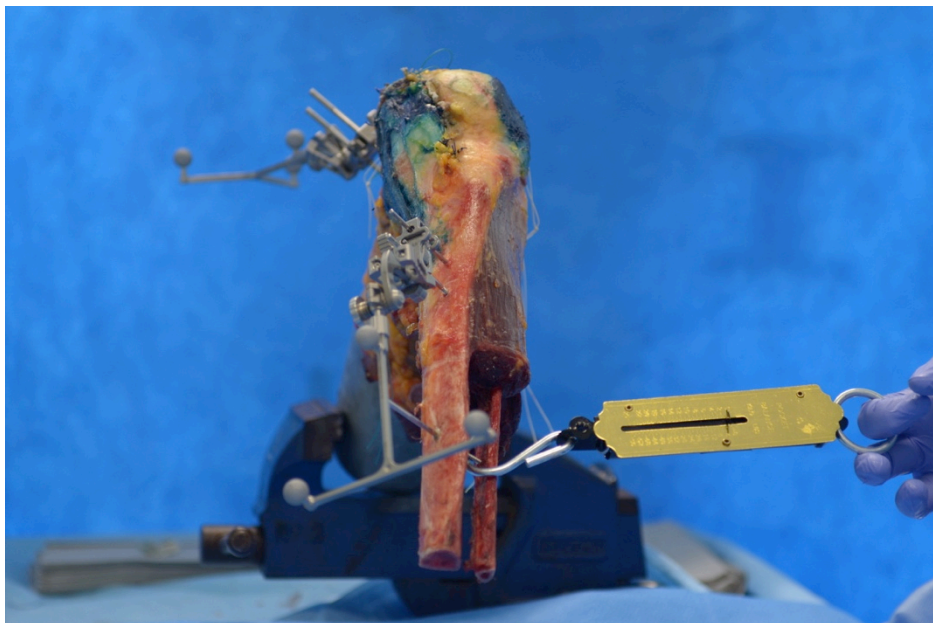
It was hypothesised that joint line elevation would significantly change the isometry of the medial collateral ligament of the knee throughout the range of motion.

## MATERIALS AND METHODS

For the methodology of the preparation of the specimens and the recording of the strain in the native sMCL, we refer to chapter 3, paragraph 3.2.1 B.

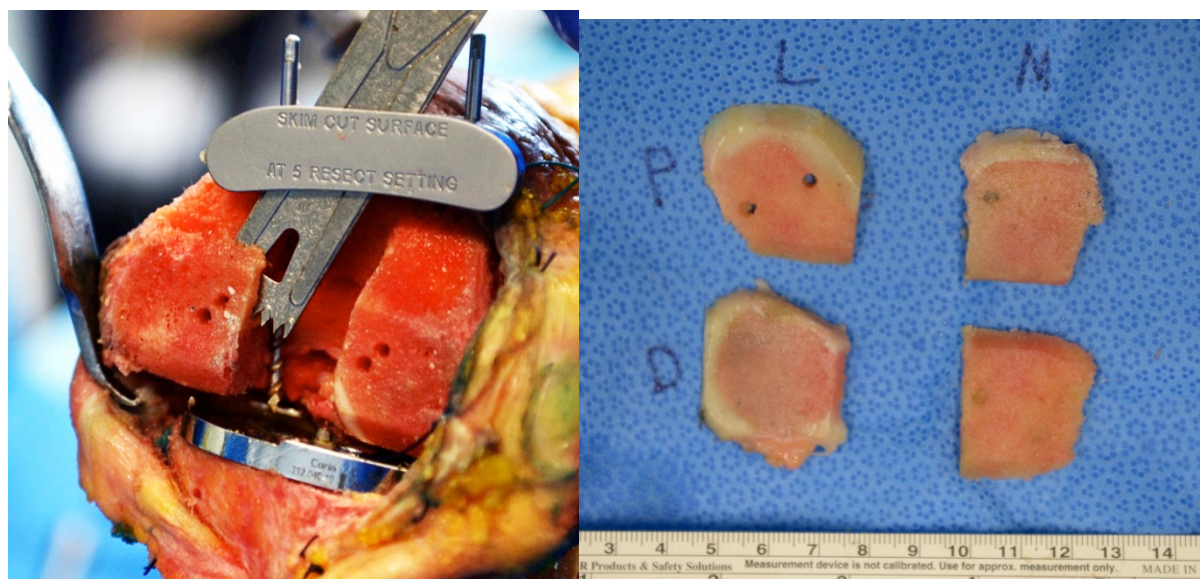
First, the maximal passive knee flexion of the native knee was recorded with use of the navigation system (Brainlab, Feldkirchen, Germany). Maximal passive knee flexion was defined as the flexion obtained by gravity. The flexion torque caused by gravity was standardised, as all specimens were severed 28 cm distal to the joint line.

The next step was the implantation of a posterior stabilised (PS) single radius total knee arthroplasty (Unity Knee™, Corin Ltd, Cirencester, UK) with the use of the navigation system. In all knees, the target for the medial distal femoral resection was 9 mm, as this equalled the implant thickness. As such the medial joint line level was restored at its original level (= TKA0 position). In all knees, a 0° mechanical axis in the coronal plan was the target. This was done by a distal femoral cut and a proximal tibial cut perpendicular to the mechanical axis. In the axial plane, the femoral component was positioned in 3° of external rotation relative to the posterior condylar line. The slope of the tibial component was set at 3°. All femoral and tibial cuts were performed and verified with the navigation system. Adjustments were made when a deviation of more than 1.0° from the planning was measured in any plane. The patella was not resurfaced.



**Figure 1:** Measurements of the joint laxity at 0° and 90° of flexion was performed by applying a standardised 10.8 Nm varus and valgus torque to the knee.

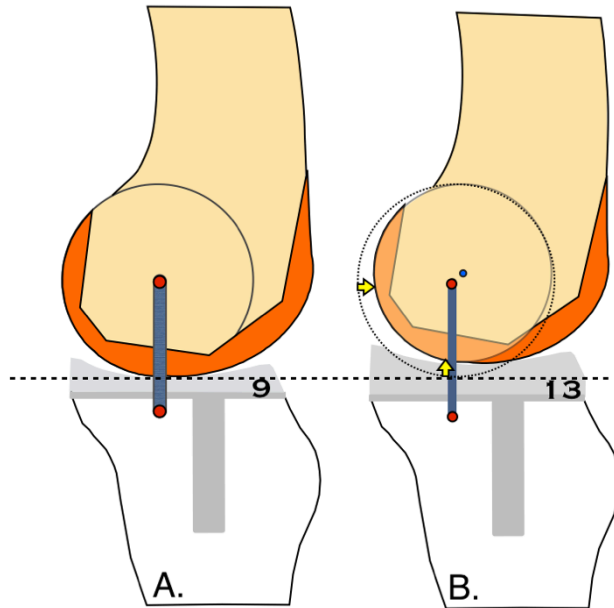
At this stage, with the trial components in place, the medial and lateral gap opening in flexion and extension were measured by applying an instrumented varus and valgus stress moment in full extension and in 90° of flexion. This was done in a standardised way by applying a 5 kg pulling force moment measured by a manual force sensor connected to a stainless steel, threaded hook that was inserted through the anterior tibia, 22 cm distal to the joint line (fig 1). The femur was fixed to prevent rotation of the lower limb. This resulted in a standardised 10.8 Nm valgus or varus torque force. During the varus/valgus testing, joint space opening was measured with the use of the navigation system. The target was to obtain an equal flexion and extension gap. Adjustments were made when a difference of more than 2° joint space opening was measured. No soft tissue releases were performed. Then, the definite components were cemented in place with the use of a polyester resin. After closure of the knee capsule, the maximal passive knee flexion was measured with the use of the navigation system. After this, the construct was again mounted in the knee rig and the strain measurements with the 3D DIC in the sMCL were repeated according to the protocol, as described in chapter 3, paragraph 3.2.1. B



**Figure 2:** The joint line was raised by removing 4 mm bone of the distal and posterior femur.

Subsequently, the components were removed and an extra 4 mm bone was removed of the distal and posterior femur with the use of the navigation system (= TKA4 position) (fig 2). A one size smaller femoral component was fitted on the distal femur. The knee stability in flexion and extension was maintained by using a 4 mm thicker polyethylene insert (fig 3). The joint laxity measurements were repeated as described above. After closure of the knee capsule, maximal passive knee flexion was again recorded. Then, the construct was mounted in the knee rig and the strain measurements were repeated.





**Figure 3:** Schematic representation of the medial side of the knee in the sagittal plane. First, a TKA was implanted with restoration of the level of the medial joint line (TKA0) (a). Next, the joint line was raised 4 mm by removing an extra 4 mm bone of the distal and the posterior femur (TKA4) (b). Stability was maintained by using a 4 mm thicker insert.

Post-processing of the data showed that the quality of the speckle pattern was insufficient in one specimen. The specimen was subsequently excluded from the analysis. The strain analysis was focused on the central fibers of the sMCL from femoral to distal tibial attachment and only longitudinal strain was reported.

#### Statistical analysis

All groups were compared with the Kruskal-Wallis test for the comparison of more than two groups. Pairwise comparison was performed by the Wilcoxon rank sum test. P-values smaller than 0.05 were considered significant. All analyses have been performed using JMP software version 11.2 for Mac of the SAS System (SAS Institute Inc., Cary, NC, USA).

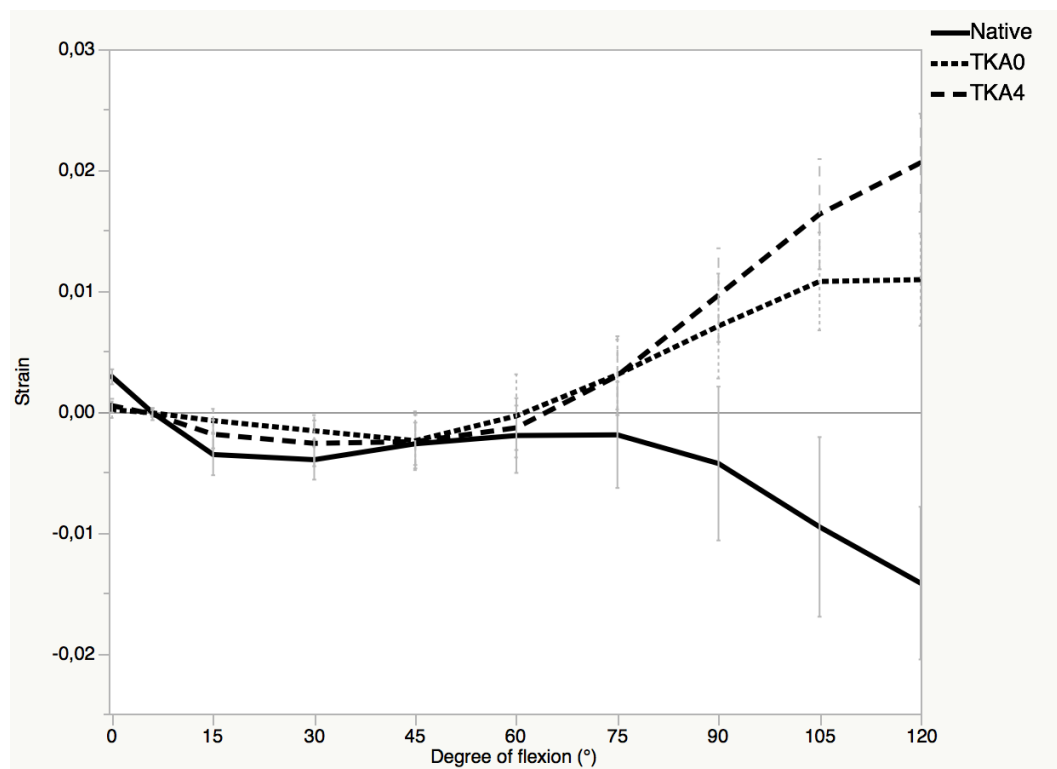
## RESULTS

The results for the strain in the native sMCL are given in table 1. The sMCL proved to be almost perfectly isometric between 15° and 90° of knee flexion. For a detailed description of the strain in the native sMCL, we refer to chapter 3, paragraph 3.2.1 B.

After TKA implantation (TKA0), the longitudinal strain in the sMCL between 0° and 75° of flexion showed some small but significant differences between the native knee and the TKA0 position (fig 4, table 1). The average maximal difference in this range of motion was 0.5% strain. In deeper flexion (90° to 120°) a reversal of the normal slackening pattern in flexion was observed with significant higher sMCL strains compared to the native knee. The increase was maximal at 120° of flexion where the difference averaged 2.5% strain.

After raising the distal and posterior joint line (TKA4), the strain in the sMCL from 0° to 90° of flexion was comparable with the TKA0 position. Only, at 15° flexion a small but significant decrease in strain was noted (table 1). In deeper flexion (90° to 120°) a further significant increase in sMCL strain was observed. The increase was maximal at 120° of flexion where the difference averaged 1% strain compared to the TKA0 position and 3.5% compared to the native knee.

The maximal passive knee flexion was on average 133° (SD 6) in the native knee. It decreased to 122° (SD 4) after TKA and to 105° (SD 6) after raising the joint line. These differences were all significant ( $p < 0.05$ ).



**Figure 4:** The strain in the sMCL during the ROM for the native knee, after TKA with restoration of the medial joint line (=TKA0) and after TKA with a 4 mm elevated joint line (=TKA4) at each flexion angle. The strain is expressed in absolute average values with standard deviation.

	Native (1)	TKA0 (2)	TKA4 (2)	Pairwise comparison			
				p value	1 vs 2	1 vs 3	2 vs 3
0°	0.3 (0.06)	0.02 (0.07)	0.05 (0.06)	<0.001	<0.001	<0.001	n.s.
Neutral (6°)	0.0 (0.04)	0.01 (0.02)	0.02 (0.05)	n.s.			
15°	-0.4 (0.2)	-0.08 (0.1)	-0.2 (0.1)	=0.001	<0.001	n.s.	< 0.05
30°	-0.4 (0.2)	-0.2 (0.1)	-0.3 (0.2)	=0.02	=0.001	n.s.	n.s.
45°	-0.3 (0.2)	-0.3 (0.2)	-0.2 (0.2)	n.s.			
60°	-0.2 (0.3)	-0.04 (0.3)	-0.1 (0.2)	n.s.			
75°	-0.2 (0.4)	0.3 (0.3)	0.3 (0.3)	=0.02	= 0.03	=0.01	n.s.
90°	-0.4 (0.6)	0.7 (0.4)	1.0 (0.4)	<0.001	<0.001	<0.001	n.s.
105°	-1.0 (0.7)	1.1 (0.4)	1.6 (0.5)	<0.001	<0.001	<0.001	<0.001
120°	-1.4 (0.6)	1.1 (0.4)	2.1 (0.4)	<0.001	<0.001	<0.001	<0.001

**Table 1:** The percentage of mean strain in the sMCL is presented for the native knee, the TKA0 and TKA4 position at each flexion angle. The standard deviation is presented between brackets. N.s. = not significant.

## DISCUSSION

The most important finding of this study was that joint line elevation with a single radius TKA caused a significant increase in strain in the sMCL in flexion beyond 90°. The differences occurred despite an equal and well-balanced flexion and extension gap with no differences in terms of gap opening between the TKA0 and the TKA4 position. During the experiment, the distal and posterior joint line were raised by 4 mm. A 4 mm extra posterior resection means a reduction of posterior condylar offset of 4 mm. Theoretically, this could lead to posterior impingement. However, no posterior impingement was observed during the experiment. There was indeed a significant decrease in passive maximal flexion after joint line elevation. However, by applying posterior force, the knee could be bent further and no firm endpoint was noted in all knees. When the posterior force was ceased, the knee jumped back to its maximal passive flexion position. We therefore believe that the reduced flexion cannot be explained by posterior impingement but should be attributed to an increase in soft tissue strain [16]. The importance of posterior condylar offset on flexion after TKA was emphasised by Bellemans et al [2]. In their study, the kinematic analysis demonstrated an

important paradoxical roll-forward of the femur in flexion in 97% of the patients indicating an afunctional posterior cruciate ligament (PCL). Hence, the patients in their series depended on a high posterior condylar offset to avoid impingement. It is now recognised that sufficient femoral rollback is equally important if not more important to achieve deep flexion and that femoral roll-forward is mainly associated with PCL retraining knees [23]. The TKA design used in our experiment was a posterior cruciate substituting design in which the post-cam interaction provides sufficient rollback to avoid impingement. The design of the tibial insert was also adapted to high flexion with no posterior lip in contrast to the design used by Bellemans et al [2].

The higher strain in the sMCL in deep flexion can explain the decrease in maximal passive flexion. This excessive elongation of the sMCL was the consequence of the proximal and anterior shift of the joint line. This observation is consistent with the work of Feeley et al. who studied the effect of different femoral sMCL insertion sites on the sMCL strain [13]. They found a great change in length of the sMCL for all non-anatomical insertions. A change in the position of the femoral component relative to the insertion sites of the collateral ligament has a similar effect on the length changes in the sMCL. Patients with a revision TKA typically have less flexion than after primary TKA. As joint line changes are very frequently observed in revision TKA, the higher strain in the sMCL could be part of the explanation for this.

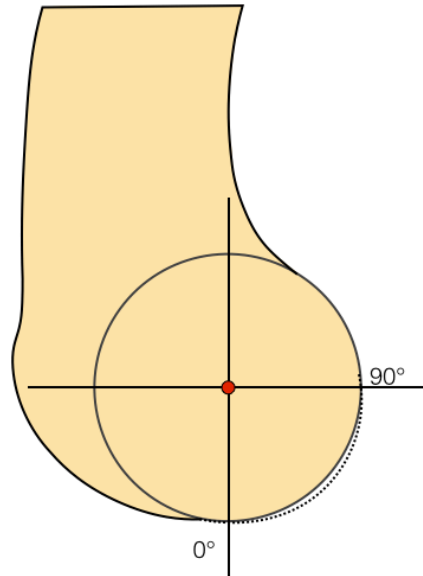
Apart from the higher strains in deep flexion, a marked increase in joint laxity in the mid-flexion range was observed in all knees after joint line elevation despite the balanced flexion and extension gap. This strengthens the point of the non-isometric sMCL behaviour due to the joint line shift. Major limitation of this observation was that observation was made by clinical judgement of the surgeon. No quantitative measurements of joint laxity were done in the mid-flexion range. It is however an observation that is consistent with the work of previous authors [7, 20]. Martin et al showed that despite a normal tension in extension and at 90°, abnormal laxity or tightness of the collaterals would occur in intermediate angles when the level of the joint line was changed [20].

Another important finding of this study was that the strain in the sMCL of the knee after a single radius TKA (=TKA0) showed some significant differences compared to the native knee. At 90° of knee flexion, a significant higher strain in the sMCL was observed after TKA. This might be attributed to the surgical technique aiming at an equal tension on the flexion and extension gap. To achieve this in an accurate and standardised way, medio-lateral gap opening in flexion and extension were measured with the navigation system and adjustments were made when necessary. In many cases this meant a postero-medial resection of 7 or 8 mm instead of 9. The benefits of a balanced flexion and extension gap seem obvious and are based on sound theory. However, there are no published biomechanical or

clinical data to confirm this recommendation. Moreover, equal tension on the flexion and extension gap is in fact an unnatural situation. Many authors have shown that medial and lateral joint space opening in flexion are greater than in extension in the native knee [8, 15, 22]. In other words, the natural knee is looser in flexion than in extension. Aiming at equal tension on the flexion gap as on the extension gap in TKA is unnatural and might therefore create a relative overstuffing of the flexion space with higher soft tissue strains as a consequence. This is especially true in a PS design, as posterior cruciate ligament resection will open up the flexion space a few extra millimetres. The higher soft tissue strains might in turn compromise deep flexion. A further increase in sMCL strain was indeed observed in deeper flexion ( $>90^\circ$ ). This is a reversal of the natural strain pattern of the sMCL showing slackening in deep flexion. The slope of the tibial component could also explain part of the observed difference in deep flexion. The importance of posterior slope on flexion after TKA is generally recognised [3]. We used a  $3^\circ$  posterior slope as standard. However, the natural slope is said to average  $7^\circ$  and a wide variation of values is reported in literature [9, 10, 14]. The relative decrease in slope introduced by TKA could explain the higher strains observed in deeper flexion. These findings are consistent with the work of Jeffcote et al [16]. They showed a significant and exponential increase in tibiofemoral force in deep flexion ( $>90^\circ$ ) that was attributed to an increase in soft tissue strain. Enlarging the flexion space by 2 mm reduced this soft tissue tension by approximately 40%.

The strain in the native sMCL in full extension was slightly but significantly higher than after TKA. A possible explanation for this is the screw home mechanism. The external rotation of the tibia relative to the femur occurring in terminal extension slightly tensions the sMCL in the native knee. After TKA this screw home mechanism was shown to be lost and so was the mild rise in sMCL strain [5]. In the mid-flexion range, the strain in the sMCL after TKA was slightly but significant higher than in the native knee. A possible explanation here is that the geometry of the single radius TKA used in the experiment is slightly more prone in the mid-flexion range when compared to the native knee (fig 5) [22]. Stoddard et al calculated that at  $45^\circ$ , a single-radius design was 1.7 mm more prone than the native knee. Thus, it elongated the sMCL by 1.7 mm in this flexion range. In fact, it is not an elongation of the sMCL that was observed but less slackening compared to the native situation. An improved stability in the mid-flexion range could be the consequence.

When interpreting the data on strain in full extension and mid-flexion, one should keep in mind that the strain measurement method was extremely sensitive. The observed differences, although significant, were subtle. Their clinical relevance needs to be determined. Nevertheless, they provide a more profound insight on the effect on sMCL strain caused by TKA.



**Figure 5:** The geometry of the femoral component in the sagittal plane in relation to an isometric circle with the superficial medial collateral ligament attachment centred at the centre of the circle (red dot). The solid line represents the isometric circle. The dotted line represents a single radius TKA.

Our study has several limitations. First of all, the number of cadaveric specimens was limited. We tested 5 specimens but due to an insufficient quality of the speckle pattern, one specimen had to be excluded. The study might therefore be underpowered to detect significant differences in the mid-flexion range. However, DIC is a very powerful and accurate tool for strain measurement that still enable us to make significant conclusion about extension and deeper flexion. Second, digital image correlation is very accurate in measuring strain caused by elongation. However, slackening of a ligament is more difficult to appreciate. Clinically, we observed a marked increase in coronal plane laxity in the mid-flexion range for the TKA4 positions. But we were not able to detect this difference with the use of DIC. Third, the study was conducted with a specific (i.e. single radius) posterior stabilised TKA design. One should therefore be careful to generalise our findings to other TKA designs. Nevertheless, the sagittal plane contour of different TKA designs does only show small differences (< 2 mm) [22]. It is therefore likely that the effect of the prosthetic geometry will be minimal compared to the 4 mm change in joint line.

## CONCLUSION

TKA significantly increased the strain in the sMCL in flexion despite a well-balanced flexion and extension gap. Joint line elevation caused further elongation of the sMCL. These higher sMCL strains might hinder knee flexion. Aiming at equal tension on the flexion and extension gap might therefore compromise deep flexion in TKA.

## REFERENCES

1. Amis AA, Oguz C, Bull a MJ, Senavongse W, Dejour D (2008) The effect of trochleoplasty on patellar stability and kinematics: a biomechanical study in vitro. *J. Bone Joint Surg. Br.* 90:864–9
2. Bellemans J, Banks S, Victor J, Vandenuecker H, Moemans a (2002) Fluoroscopic analysis of the kinematics of deep flexion in total knee arthroplasty. Influence of posterior condylar offset. *J. Bone Joint Surg. Br.* 84:50–3
3. Bellemans J, Robijns F, Duerinckx J, Banks S, Vandenuecker H (2005) The influence of tibial slope on maximal flexion after total knee arthroplasty. *Knee Surg. Sports Traumatol. Arthrosc.* 13:193–6
4. Bellemans J, Vandenuecker H, Victor J, Vanlauwe J (2006) Flexion contracture in total knee arthroplasty. *Clin. Orthop. Relat. Res.* 452:78–82
5. Chew JT, Stewart NJ, Hanssen AD, Luo ZP, Rand JA, An KN (1997) Differences in patellar tracking and knee kinematics among three different total knee designs. *Clin. Orthop. Relat. Res.* 87–98
6. Cope MR, O'Brien BS, Nanu AM (2002) The influence of the posterior cruciate ligament in the maintenance of joint line in primary total knee arthroplasty: a radiologic study. *J Arthroplast.* 17:206–208
7. Cross MB, Nam D, Plaskos C, Sherman SL, Lyman S, Pearle AD, Mayman DJ (2012) Recutting the distal femur to increase maximal knee extension during TKA causes coronal plane laxity in mid-flexion. *Knee* 19:875–9
8. Van Damme G, Defoort K, Ducoulombier Y, Van Glabbeek F, Bellemans J, Victor J (2005) What should the surgeon aim for when performing computer-assisted total knee arthroplasty? *J. Bone Joint Surg. Am.* 87 Suppl 2:52–8
9. Dejour H, Bonnin M (1994) Tibial translation after anterior cruciate ligament rupture. Two radiological tests compared. *J Bone Jt. Surg Br* 76:745–749
10. Dejour H, Neyret P, Boileau P, Donell ST (1994) Anterior cruciate reconstruction combined with valgus tibial osteotomy. *Clin Orthop Relat Res* 220–228
11. Ensini A, Catani F, Biasca N, Belvedere C, Giannini S, Leardini A (2012) Joint line is well restored when navigation surgery is performed for total knee arthroplasty. *Knee Surg. Sports Traumatol. Arthrosc.* 20:495–502
12. Farahmand F, Senavongse W, Amis AA (1998) Quantitative study of the quadriceps muscles and trochlear groove geometry related to instability of the patellofemoral joint. *J. Orthop. Res.* 16:136–43
13. Feeley BT, Muller MS, Allen A a, Granchi CC, Pearle AD (2009) Isometry of medial collateral ligament reconstruction. *Knee Surg. Sports Traumatol. Arthrosc.* 17:1078–82
14. Hashemi J, Chandrashekar N, Gill B, Beynon BD, Slaughterbeck JR, Schutt RC, Mansouri H, Dabezies E (2008) The geometry of the tibial plateau and its influence on the biomechanics of the tibiofemoral joint. *J. Bone Joint Surg. Am.* 90:2724–34
15. Hunt NC, Ghosh KM, Blain AP, Athwal KK, Rushton SP, Amis A a, Longstaff LM, Deehan DJ (2014) How does laxity after single radius total knee arthroplasty compare with the native knee? *J. Orthop. Res.* 32:1208–13

16. Jeffcote B, Nicholls R, Schirm a, Kuster MS (2007) The variation in medial and lateral collateral ligament strain and tibiofemoral forces following changes in the flexion and extension gaps in total knee replacement. A laboratory experiment using cadaver knees. *J. Bone Joint Surg. Br.* 89:1528–33
17. Kawamura H, Bourne RB (2001) Factors affecting range of flexion after total knee arthroplasty. *J Orthop Sci* 6:248–252
18. LaPrade RF, Engebretsen AH, Ly T V, Johansen S, Wentorf F a, Engebretsen L (2007) The anatomy of the medial part of the knee. *J. Bone Joint Surg. Am.* 89:2000–10
19. Luyckx T, Verstraete M, De Roo K, De Waele W, Bellemans J, Victor J (2014) Digital image correlation as a tool for three-dimensional strain analysis in human tendon tissue. *J. Exp. Orthop.* 1:7
20. Martin JW, Whiteside L a (1990) The influence of joint line position on knee stability after condylar knee arthroplasty. *Clin. Orthop. Relat. Res.* 259:146–56
21. Snider MG, Macdonald SJ (2009) The influence of the posterior cruciate ligament and component design on joint line position after primary total knee arthroplasty. *J. Arthroplasty Elsevier B.V.* 24:1093–8
22. Stoddard JE, Deehan DJ, Bull AMJ, McCaskie AW, Amis A a (2013) The kinematics and stability of single-radius versus multi-radius femoral components related to mid-range instability after TKA. *J. Orthop. Res.* 31:53–8
23. Victor J, Bellemans J (2006) Physiologic kinematics as a concept for better flexion in TKA. *Clin. Orthop. Relat. Res.* 452:53–8
24. Victor J, Labey L, Wong P, Innocenti B, Bellemans J (2010) The influence of muscle load on tibiofemoral knee kinematics. *J. Orthop. Res.* 28:419–28
25. Victor J, Wong P, Witvrouw E, Sloten J Vander, Bellemans J (2009) How isometric are the medial patellofemoral, superficial medial collateral, and lateral collateral ligaments of the knee? *Am. J. Sports Med.* 37:2028–36



### 3.3 THE EFFECT OF JOINT LINE ELEVATION ON CORONAL PLANE STABILITY OF THE KNEE.

---

**T Luyckx, H Vandenneucker, E Vereecke, L Scheys, A Victor, J Victor**

Raising the joint line in TKA causes significant mid-flexion instability.

*Manuscript submitted to the journal of Clinical Orthopaedics and Related Research*

Finalist of the best paper award at the ICJR World Arthroplasty Congress, Paris, 2015.

#### ABSTRACT

##### **Background**

Restoring the joint line at its original level is a prerequisite for a good functional outcome after total knee arthroplasty (TKA). However, the biomechanical effect of raising the joint line remains poorly understood.

##### **Purpose**

The purpose of this study was to investigate the effect of joint line elevation in TKA on the varus/valgus stability of the knee, throughout the flexion arc.

##### **Methods**

A TKA was implanted in 10 fresh frozen cadaveric knees with restoration of the medial joint line at its original level (TKA0). Coronal plane stability was measured with a navigation system (Brainlab, Feldkirchen, Germany) while applying an instrumented 9.8 Nm varus and valgus torque. Afterwards, the joint line was raised in two steps by re-cutting the distal and posterior femur by an extra 2 mm (TKA2) and 4 mm (TKA4) and respectively adding a 2 and 4 mm thicker insert.

##### **Results**

After TKA, no differences were observed in extension between the normal and the 2 mm and 4 mm raised joint line. In mid-flexion (30° and 60°) however, a significant increase in coronal plane laxity was observed for the TKA2 and TKA4 position (fig. 3). The first distal recut of + 2 mm (TKA2) increased the coronal plane laxity by on average 64% (3.1°) at 30° of flexion ( $p < 0.01$ ) and 51% (3.0°) at 60° of flexion ( $p = 0.02$ ). Performing the second + 2 mm recut (TKA4) of the distal femur increased

the mid-flexion laxity by 111% (5.4°) ( $p < 0.01$ ) at 30° and 95% (5.5°) at 60° of flexion ( $p < 0.01$ ) compared to the 9 mm baseline resection (TKA0). At 90° and 120°, no significant differences were observed between the 3 groups.

From a linear regression model, it was calculated that for every millimetre rise in joint line level, a 31% increase in coronal plane laxity at 30° and a 25% increase at 60° can be expected.

### **Conclusion**

Raising the medial joint line caused significant mid-flexion instability despite an equal and well-balanced flexion and extension gap. No effect of the orientation of the joint line (mechanical vs anatomical) on joint stability was found.

Restoration of the level of medial joint line was found to be the key to coronal plane joint stability in TKA.

## **INTRODUCTION**

Joint stability is considered of major importance for the functional outcome of a total knee arthroplasty (TKA). In fact, instability has recently become the number one cause for early revision after TKA [26]. Its importance should therefore not be underestimated.

In contrast to alignment, joint stability remains a difficult parameter to quantify objectively. In most cases, joint stability is qualitatively assessed intra-operatively by the surgeon by manual varus-valgus stress testing at 0° and 90°. The stability in the mid-flexion range is frequently not taken into account. During most activities of daily living however, the knee is not only loaded near full extension but also in mid-flexion [18, 19]. Therefore stability throughout the mid-flexion range should be considered an important outcome measure in TKA. Failure to reproduce the required stability in the mid-flexion range can result in pain and an unstable feeling while walking, giving way, persistent synovitis and even recurrent hemarthrosis, especially in male patients.

During revision TKA, there is a strong tendency to raise the joint line. But also in the primary setting, the joint line is frequently raised [5, 8, 17, 28]. This is in part due to surgical instrumentation of the procedure, using the worn distal femur as a reference. Failure to compensate for distal femoral bone loss will automatically result in a raised joint line. Also, in case of a fixed flexion contracture, resection of additional distal femoral bone to obtain full extension is advocated by many surgeons [2, 16]. Additional distal femoral resection has indeed been proven to increase maximal knee extension [6]. However, it is important to realise that a flexion contracture is not the consequence of distal femoral overgrowth. As a result, correcting the capsule-ligamentous problem causing the extension deficit by additional bone resection might introduce new problems [6].

The link between the level of the joint line and coronal plane stability of the joint was observed in previous studies, none of which explained however why raising the joint line would lead to mid-flexion instability [6, 21].

The purpose of our study was as follows:

1. Quantify the effect of TKA implantation, with restoration of the medial joint line, on the coronal plane stability of the knee;
2. Quantify the effect of joint elevation on coronal plane stability of the knee;

## MATERIALS AND METHODS

### Experimental protocol

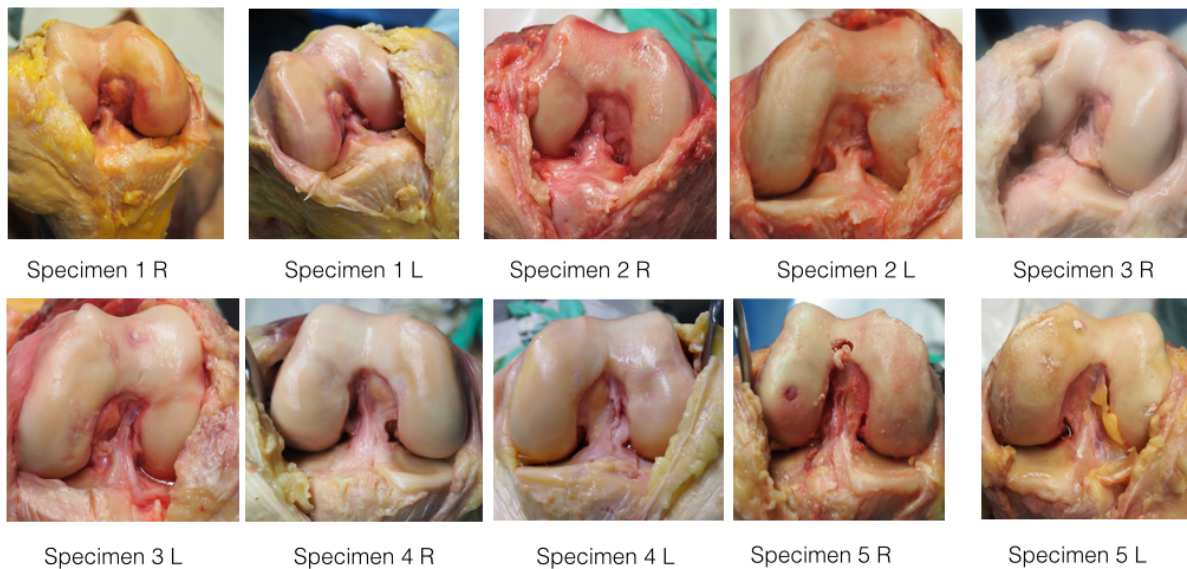
The study protocol was approved by the local Ethics committee. Five fresh frozen full body specimens (10 knees) were obtained by the human body donation programme of the university. There were three male and two female human donors and they were between 55 and 85 years of age at the time of death. The specimens were stored at -18°C prior to the experiment. The demographic variables of the specimens are presented in table 1.

	HKA-angle			
	Sex	Age	Left	Right
<b>Specimen 1</b>	Male	71	2.0°	0.0°
<b>Specimen 2</b>	Female	70	3.0°	5.0°
<b>Specimen 3</b>	Male	64	- 3.0°	- 2.0°
<b>Specimen 4</b>	Male	55	1.0°	-1.5°
<b>Specimen 5</b>	Female	85	0.5°	1.5°

**Table 1:** Demographic variables of the specimens

Prior to testing, the specimens were thawed for 48h at a room temperature of 20° C. Wet towels and water spraying prevented drying of the specimen throughout the experiment. Each knee (n = 10) was carefully checked for abnormalities during exposure. Exclusion criteria were: previous surgery on the knee, abnormal anterior-posterior or medial-lateral ligamentous laxity, varus or valgus alignment of more than 6° and significant osteoarthritis. No specimen had to be excluded (fig 1).

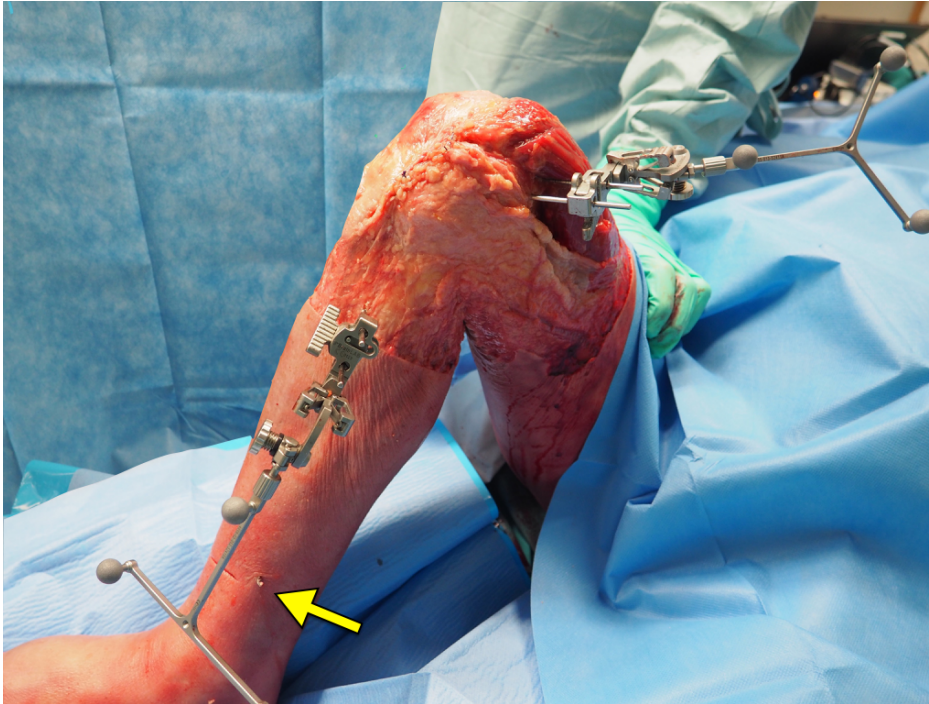
An anterior midline incision was made, followed by a standard subvastus arthrotomy. Two pins for the navigation frames were respectively placed in the distal femur and proximal tibia according to the manufacturer's recommendations. The position of the femoral pins was chosen so that interference with the closure of the joint capsule and with the extensor mechanism was avoided (fig 2). Bone morphing acquisitions of the femur and tibia were performed with the use of the navigation system (Brainlab, Feldkirchen, Germany). Resection of the anterior horn of the medial and lateral meniscus was necessary to be able to reach the joint surfaces. The knee capsule was then anatomically closed.



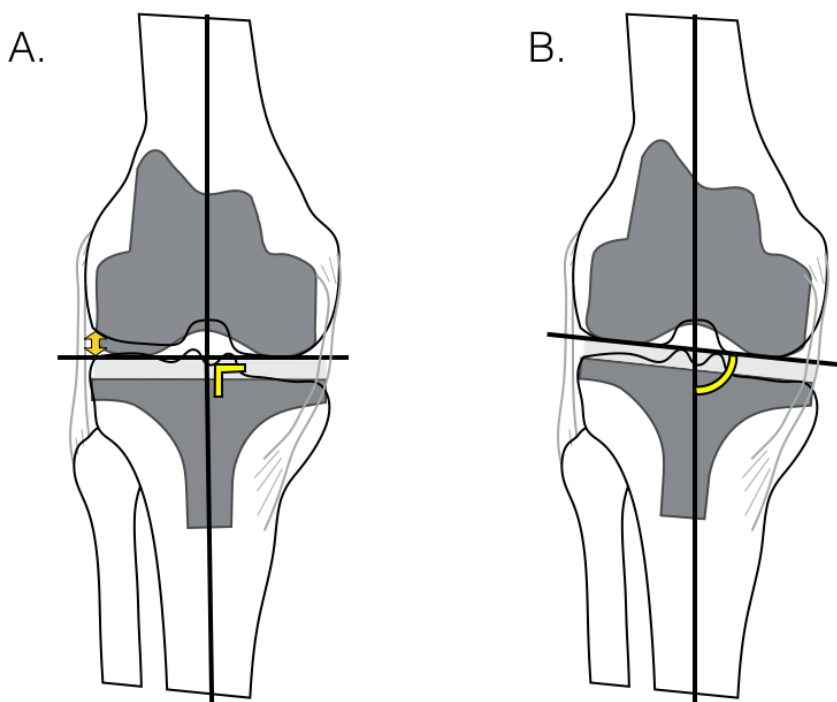
**Figure 1:** Photograph of each knee after subvastus arthrotomy. Integrity of the joint was confirmed.

At this stage, the natural joint laxity was measured by applying an instrumented varus and valgus stress moment at full extension, 30°, 60°, 90° and 120° of flexion. This was done in a standardised way by applying a 40 N pulling force moment measured by a digital force sensor connected to a stainless steel, threaded hook that was inserted through the anterior tibia, 25 cm distal to the joint line (fig 2). This resulted in a standardised 9.8 Nm valgus or varus torque force. During the varus/valgus testing, rotation of the lower limb was prevented by applying counter force on the femoral pins. Joint laxity was expressed as the sum of the maximum varus and valgus deviations measured under the applied stress.

Next, a posterior stabilised (PS) single radius total knee arthroplasty (Unity Knee™, Corin Ltd, Cirencester, UK) was implanted using the navigation system. In all knees, the target for the medial



**Figure 2:** The full-limb specimen prepared with the navigation frames in place. The subvastus arthrotomy was anatomically closed. A threaded pin was inserted 25 cm distal to the joint line (arrow) for the application of the varus/valgus torque.



**Figure 3:** All TKA's were implanted with restoration of the medial joint line. In 5 knees the joint line was aligned perpendicular to the mechanical axis (= mechanical alignment) (A). In the 5 contra-lateral knees, the lateral joint line was also restored at its original level (anatomical alignment) thereby restoring the obliquity of the natural joint line (B).

distal and posterior medial femoral resection was 9 mm, as this equalled the implant thickness. As such the medial joint line level was restored at its original level (= TKA0 position).

The full body specimens were randomised for having the TKA implanted with neutral mechanical alignment in one side and with anatomical (= kinematical) alignment in the other. The mechanical alignment (5 knees) was performed with the 0° mechanical axis in coronal plane as target. This was done by a distal femoral cut and a proximal tibial cut perpendicular to the mechanical axis. It implied a relative under-resection of the distal lateral femoral surface and a relative over-resection of the lateral proximal tibial surface (fig 3A). In the axial plane, the femoral component was positioned in 3° of external rotation relative to the posterior condylar line.

The anatomical (or kinematic) alignment (5 knees) was performed by doing the distal femoral cut and the proximal tibial cut parallel to the original distal femoral and proximal tibial joint surface respectively. By doing this, the natural joint line obliquity was restored (fig 3B). In the axial plane, the femoral component was positioned parallel to the posterior condyles with no external rotation.

The slope of the tibial component was set to match the natural medial slope in all knees with 7° of posterior slope as a limit. All femoral and tibial cuts were performed and verified with the navigation system. Adjustments were made when a deviation of more than 1.0° from the planning was measured in any plane. No soft tissue releases were performed.

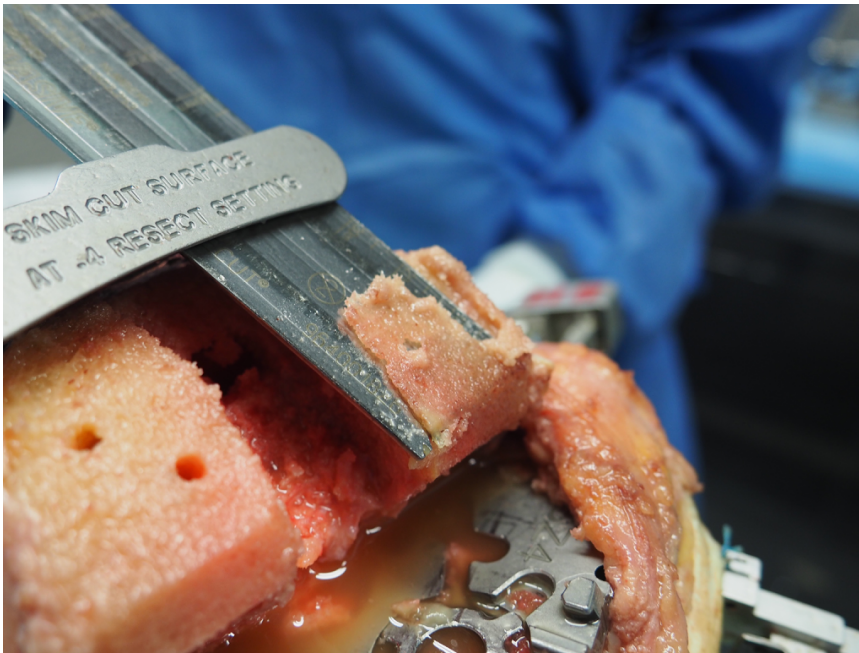
After closure of the knee capsule, the joint laxity measurements were repeated as described above with the trial components in place.

Next, the trial components were removed and 2 mm extra bone was removed of the distal and posterior femur with the use of the navigation software (= TKA2 position) (fig 4). The knee stability in flexion and extension was maintained by using a 2 mm thicker polyethylene insert. After closure of the knee capsule, the joint laxity measurements were repeated as described above with the trial components in place. If stability of the trial component was insufficient, a definite component was cemented in place with the use of a polyester resin. This allowed stable fixation of the components and did not cause bone loss during removal of the component.

Next, an extra 2 mm (so 4 mm in total) of bone was removed of the distal and posterior femur with the use of the navigation system (= TKA4 position). The knee stability in flexion and extension was again maintained by using a 2 mm thicker polyethylene insert. After closure of the knee capsule, the joint laxity measurements were repeated as described above with the trial components in place. Again, if the stability of the trial component was insufficient, a definite component was cemented in place.

### *Statistical analysis*

An a priori power analysis with an alpha level of 0.05 showed a power of 0.85 to detect a difference of 3° in coronal plane stability between the mechanically and anatomically aligned TKA's and a power of 0.98 to detect a difference of 3° in coronal plane stability between the TKA0, TKA2 and TKA4 position. All groups were compared with the Kruskal-Wallis test for the comparison of more than two groups. Pairwise comparison was performed by the Wilcoxon rank sum test. P-values smaller than 0.05 are considered significant. All analyses have been performed using JMP software version 11.2 for Mac of the SAS System (SAS Institute Inc., Cary, NC, USA).



**Figure 4:** The joint line was raised by removing 2 millimetres of extra bone of the distal and posterior femur in 2 steps.

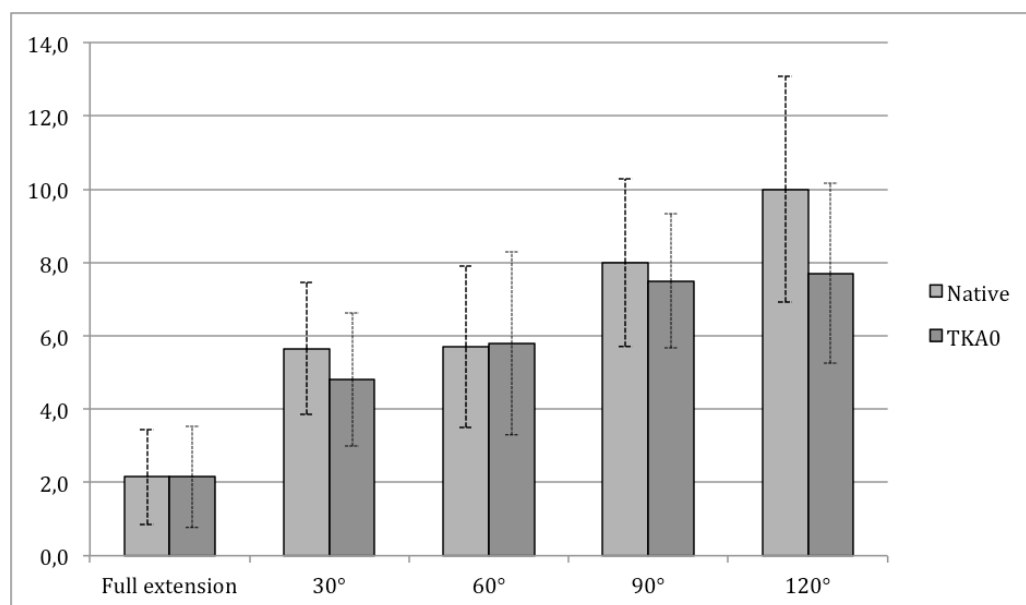
## RESULTS

The mean coronal plane laxity in full extension for **the native knee** was 2.2° (SD 1.3°). At 30° of flexion the laxity was 5.7° (SD 1.8), at 60° of flexion 5.7° (SD 2.2), at 90° of flexion 8.0° (SD 2.3) and at 120° of flexion 10.0° (SD 3.1°) (fig 2). This increase in laxity with flexion was statistically significant with  $p < 0.05$  for all positions except for the 30° vs 60° position and the 90° vs 120° position.

The mean coronal plane laxity in full extension after implantation of a TKA with restoration of the medial joint line (**TKA0**) was 2.6° (SD 1.6°). At 30° of flexion the laxity was 4.4° (SD 1.5), at 60° of flexion 5.2° (SD 2.1), at 90° of flexion 7.0° (SD 1.8) and at 120° of flexion 7.9° (SD 2.3°) (fig 2). This



increase in laxity with flexion was statistically significant with  $p < 0.05$  for all positions except for the 30° vs 60° position and the 90° vs 120° position. No significant differences were observed in coronal plane laxity between the normal knee and the TKA0 position at any flexion angle (fig 2). No significant differences were found between the knees implanted with anatomical alignment vs mechanical alignment at any flexion angle.

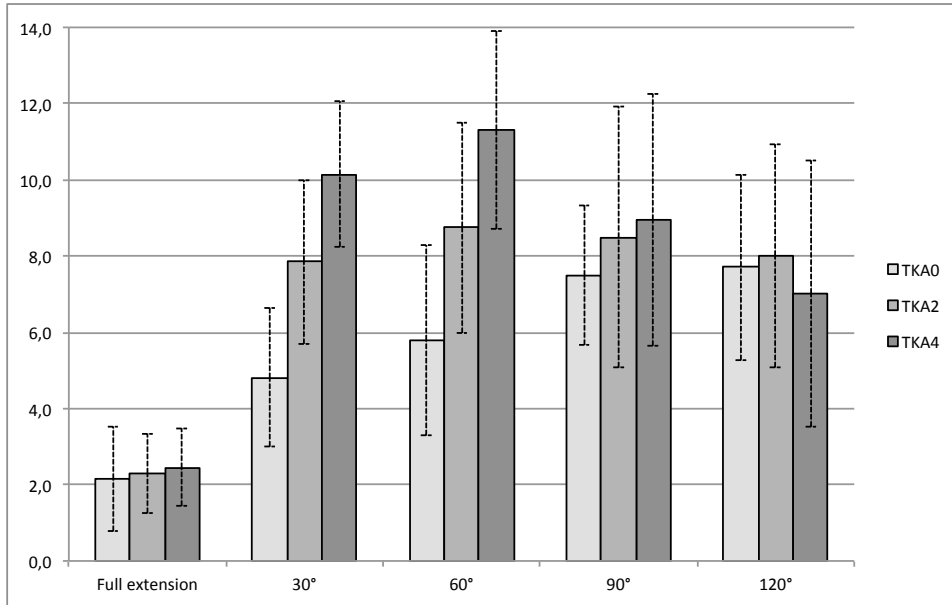


**Figure 5:** Mean coronal plane joint laxity in degrees is presented for each flexion angle. Results for the native knee and the TKA with the restored medial joint line are shown (TKA0). No statistical significant differences were noted between the native knee and the TKA0 position. Error bars indicate the standard deviation.

The absolute values for the coronal plane joint laxity throughout the range of motion for the **TKA2** and **TKA4** position are given in table 2. After raising the joint line, in extension no significant differences were observed between the three TKA positions (TKA0, TKA2, TKA4) in terms of coronal plane stability. In mid-flexion (30° and 60°) however, a significant increase in coronal plane laxity was observed for the TKA2 and TKA4 position (fig 3). The first distal recut of + 2 mm (TKA2) increased overall coronal plane laxity by on average 64% (3.1°) at 30° of flexion ( $p < 0.01$ ) and 51% (3.0°) at 60° of flexion ( $p = 0.02$ ). Performing a second + 2 mm recut (TKA4) of the distal femur increased the mid-flexion laxity by 111% (5.4°) ( $p < 0.01$ ) at 30° and 95% (5.5°) at 60° of flexion ( $p < 0.01$ ), compared to the 9 mm baseline resection (TKA0). At 90° and 120°, no significant differences were observed between the three groups.

A near perfect linear correlation between the level of the joint line and the coronal plane stability was found ( $R^2 = 0.99$ ). From the linear regression model, it was calculated that for every millimetre rise in joint line level, a 31% increase in coronal plane laxity at 30° and a 25% increase at 60° can be expected.





**Figure 6:** Mean coronal plane joint laxity in degrees is presented for each flexion angle. Results for the TKA with the restored joint line (TKA0), the 2 mm (TKA2) and 4 mm (TKA4) raised joint line are shown. No statistical significant differences were noted between the 3 groups in extension or at 90° and 120° of flexion. However, a significant increase in coronal plane laxity was noted at 30° and 60° of flexion.

	TKA0	TKA2	TKA4	Pairwise comparison			
				p value	1 vs 2	1 vs 3	2 vs 3
Full extension	2.2° (1.4)	2.3° (1.1)	2.5° (1.0)	n.s.			
30°	4.8° (1.8)	7.9° (2.2)	10.2° (1.9)	<0.001	0.007	< 0.001	0.023
60°	5.8° (2.5)	8.8° (2.5)	11.3° (2.6)	<0.001	0.025	0.001	0.046
90°	7.5° (1.8)	8.5° (3.4D)	9.0° (3.3)	n.s.			
120°	7.7° (2.5)	8.0° (2.9)	7.0° (3.5)	n.s.			

**Table 2:** Mean coronal plane joint laxity of the in degrees is presented for each joint line position (TKA0, TKA2, TKA4) at each flexion angle. Joint laxity is expressed as the sum of the maximum varus and valgus deviations measured under stress. The standard deviation is presented between brackets.

## DISCUSSION

The concept of mid-flexion instability remains poorly defined and understood. It was first introduced by Martin and Whiteside who found a significant laxity in the mid-flexion range (30°-60°) by shifting the femoral component of a TKA 5 mm proximal and 5 mm anterior [21]. Mid-flexion instability was therefore defined as instability in the mid-flexion range (30°-60°). We like to add to the definition:

despite an equally balanced flexion and extension gap. It should be separated from other forms of coronal plane instability, which are the consequence of a mismatch between the flexion and extension gap. In a true flexion instability for instance, the flexion gap is too large in comparison to the extension gap. In extension instability, the extension gap is too large in comparison to the flexion gap. In a pure mid-flexion instability however, the instability occurs in the mid-flexion range despite a well-balanced flexion and extension gap. As most surgical routines only involve testing of stability in full extension and at 90° of flexion, this type of instability is frequently overlooked. In a recent report using computer navigation, Yoon et al. were able to demonstrate a significant mid-flexion laxity in 36% of their patients during TKA's during surgery [31]. In mobile bearing uni-compartmental knee arthroplasty, it is already recognised that evaluating the stability of the knee should be done at 20° of flexion instead of full extension. We therefore recommend that the evaluation of the stability in the mid-flexion range becomes common practice during TKA surgery as well.

Our study has some limitations. First of all, all TKA's implanted were posterior stabilised (PS) knees. The posterior cruciate ligament is known to have an important effect on coronal plane stability. Removal is likely to affect stability in the mid-flexion range. Hino et al. demonstrated significantly more mid-flexion laxity in a PS TKA vs. a cruciate retaining TKA [10]. However, it is crucial to take the level of the joint line into account. PS surgeons will in many cases raise the joint line to compensate for the increase in flexion space due to the cutting of the posterior cruciate ligament (PCL). The level of the joint line is therefore an important confounding variable for every study that measures coronal plane stability. By using computer navigation and a strict measured resection technique, we were able to keep the medial joint line at its original level in all our specimens.

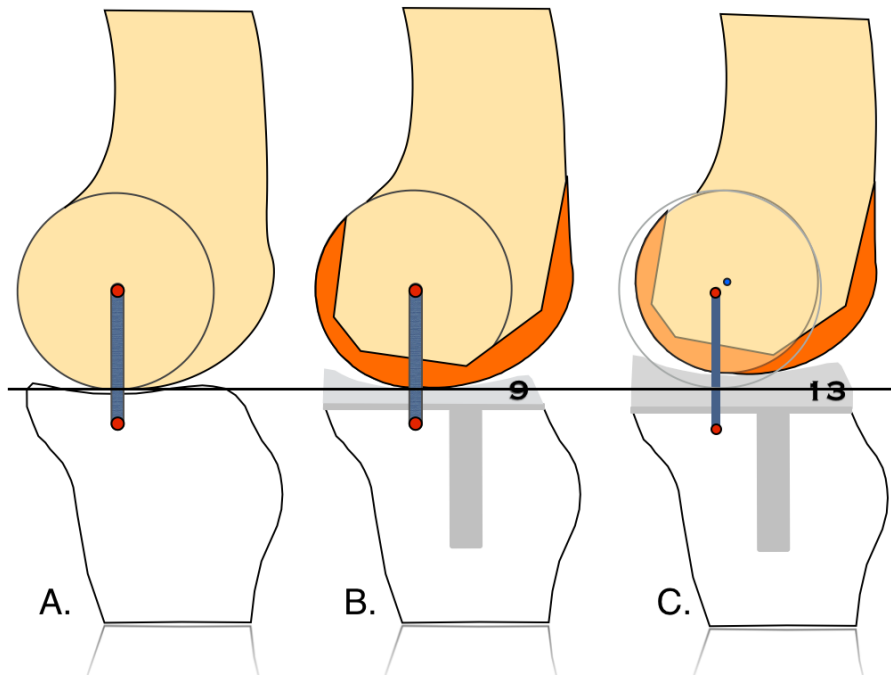
Second, the native joint laxity was measured after resection of the anterior horn of the medial meniscus and lateral meniscus. Removal was needed to map the joint surface with the navigation software. Removal of the meniscus is known to have an effect on antero-posterior and rotational stability but the effect on coronal plane stability is unknown [3, 22, 30]. Despite the fact that only the anterior portion of the medial meniscus was removed and the body of the meniscus with its attachments to the deep MCL was left untouched, we cannot exclude an effect on coronal plane stability. Nevertheless, our results for native knee varus-valgus stability were very comparable with those of others [14]. Third, because this was a cadaveric study, we do not know how dynamic forces (i.e. muscle contractions) affect the degree of mid-flexion laxity in the in vivo situation. However, the purpose of the study was to evaluate the effect of joint line elevation on the static varus/valgus stabilisers of the knee. This study serves as a proof of concept that raising the joint line leads to increased mid-flexion coronal plane laxity. An increase of more than 50% or 100% in passive laxity is very likely to also affect dynamic stability. Finally, it should be noted that it is unknown what degree of

joint laxity can be tolerated after TKA before clinical symptoms occur which makes it difficult to draw conclusions on the clinical significance. Moreover, the amount of laxity that is tolerated is very likely subject-specific with a wide variation throughout the population. Defining a clinically significant average threshold is therefore less useful.

Before reporting on pathological laxity or instability of a joint, the normal laxity throughout the range of motion should be defined first. As shown in figure 5, gradual increase in laxity from full extension to 120° of flexion was observed in the native knee. This finding is consistent with the clinical practice and the findings of previous authors [4, 7, 21, 29]. Our study showed the restoration of the native coronal plane stability throughout the range of motion with the use of a PS single radius TKA design when the medial joint line was restored at its original level. These findings have been confirmed by others, using a single radius cruciate retaining TKA design and a dual radius cruciate retaining design [7, 14].

Some authors have suggested that anatomical alignment might cause mid-flexion instability [15]. However, in our study no effect of the orientation of the joint line (mechanical vs anatomical) on coronal plane stability was found. In other words, the restoration of the level of the medial joint line was the only prerequisite for restoration of normal joint laxity, irrespective of the joint line orientation in the coronal plane. Thus, the level of the lateral joint line was shown to be of no importance to the coronal plane joint stability.

The effect of the joint line position on knee stability and ligament balance was suggested by previous authors. In 1985, Hungerford stated: "ligament balance is principally a function of the femoral component and joint line positions relative to the femoral origins of the collateral and cruciate ligaments" [13]. It is clear from our data that this statement is indeed true. We showed in an experimental setup, that raising the JL by 2 mm caused an increase of 64% in joint laxity at 30° of flexion and 51% at 60° of flexion, and this despite a well-balanced flexion and extension gap. Although a 2 mm increase might seem minimal, it is very frequently encountered during primary TKA surgery and its effect on coronal plane stability was found to be significant. When the JL is raised by 4 mm, the mid-flexion joint laxity becomes even more clear. Raising the joint line by 4 mm may be encountered less frequently during primary TKA but is very frequently seen in revision TKA. Moreover, joint line changes of 4 mm and more are associated with an inferior clinical result [11, 24, 25, 27]. But also after primary TKA, maintaining the joint line at its original level has shown to improve the functional outcome [1]. Some authors suggested that the explanation for the association of the elevated joint line with the inferior clinical result was due to mid-flexion laxity [24].



**Figure 7:** Schematic representation of the medial side of the knee in the sagittal plane. The femoral condyle is depicted as an 'isometric' circle. The red dots indicate the femoral and proximal tibial insertion site of the sMCL (in grey). On the femoral side, the insertion site of the sMCL coincides with the flexion-extension axis (a). Restoration of the distal and posterior joint line after a single radius TKA reproduces the same flexion-extension axis (b). The joint line is raised by using a 4 mm smaller femoral component in a 4 mm proximal position and a 4 mm thicker polyethylene insert (c). The circle depicts the original level of the joint line. This causes a shift of the centre of rotation to proximal and anterior (bleu dot). As this centre no longer coincides with the femoral insertion site of the sMCL, it is likely to affect sMCL isometry.

Despite the fact that the link between the level of the joint line and the coronal plane laxity was suggested by previous authors, an explanation for the association is lacking. A change in the sMCL isometry could explain the observed differences in joint stability (fig 7). As the superficial medial collateral ligament (sMCL) is the primary stabiliser against valgus stress, the concept of its isometry is crucial for knee stability. Any change in its isometry will affect coronal plane stability. Raising the joint line in TKA will change the tibiofemoral centre of rotation from its original position (fig 7C). As the femoral insertion site of the sMCL is not altered, it will pivot around the new centre of rotation during knee flexion and its isometric behaviour will be changed. This is consistent with the work of others. While determining the isometric point of the sMCL on the femur and tibia, Feeley et al found an important increase in strain in the sMCL for the non-anatomical insertions [9]. Moving the femoral origin of the sMCL distally by 4 mm led to graft excursion of greater than 8 mm. A change in joint line position has a similar effect on the relation between insertion site of the collateral ligaments and the centre of rotation of the knee (fig 7). In a cadaver experiment, Martin et al investigated varus-valgus,

anterior-posterior and rotational stability after TKA [21]. They found no significant change in stability when the joint line was maintained in its natural position. However, when the femoral component was repositioned 5 mm proximally and 5 mm anteriorly, a significant increase in laxity occurred during mid-flexion. When the joint line was shifted 5 mm distal and 5 mm posterior to its anatomic location, significant tightening occurred in midrange of motion. More recently, Cross et al. found that raising the joint line during TKA to increase maximal extension, caused significant mid-flexion instability [6].

Our experimental data confirm these findings and quantified the effect. In an attempt to provide a more profound insight in the association between the level of the medial joint line and joint stability, we developed a geometrical model. We refer to chapter 3.4 for further explanation.

The level of the distal and posterior joint line, are the key to the collateral ligament isometry and knee stability. The implication for TKA surgery is that restoration of the medial joint line is a prerequisite for maintenance of sMCL isometry and normal joint stability. In revision TKA, the bony landmarks around the knee can be used to determine the level of the medial joint line [20]. In primary TKA, the distal medial femoral joint surface can be used as reference landmark. The thickness of the distal medial femoral resection, together with the curve of the blade should match the implant thickness (typically 9 mm) [12]. One should take into account cartilage and bone loss due to the OA process while doing this. Nam et al. showed that in extension, this bone loss is minimal in most cases and full thickness cartilage loss accounts for around 2 mm thickness [23]. This should be combined with a posterior medial femoral resection that also matches the implant thickness (9 mm). Doing so will restore both the medial distal and posterior joint line to their original level, thereby reconstructing the joint surface geometry at its original level. Native sMCL isometry and joint stability will be reproduced as a consequence.

Further research is needed to prove that this concept does indeed improve joint stability and clinical outcome after TKA.

## CONCLUSION

Raising the medial joint line caused significant mid-flexion instability despite an equal and well-balanced flexion and extension gap. No effect of the orientation of the joint line (mechanical vs anatomical) on joint stability was found. Restoration of the level of medial joint line was found to be the key to coronal plane joint stability in TKA.

## REFERENCES

1. Babazadeh S, Dowsey MM, Swan JD, Stoney JD, Choong PFM (2011) Joint line position correlates with function after primary total knee replacement: A RANDOMISED CONTROLLED TRIAL COMPARING CONVENTIONAL AND COMPUTER-ASSISTED SURGERY. *J. Bone Joint Surg. Br.* 93:1223–31
2. Bellemans J, Vandenuecker H, Victor J, Vanlauwe J (2006) Flexion contracture in total knee arthroplasty. *Clin. Orthop. Relat. Res.* 452:78–82
3. Chen L, Linde-Rosen M, Hwang SC, Zhou J, Xie Q, Smolinski P, Fu FH (2014) The effect of medial meniscal horn injury on knee stability. *Knee Surg. Sports Traumatol. Arthrosc.*
4. Coobs BR, Wijdicks C a, Armitage BM, Spiridonov SI, Westerhaus BD, Johansen S, Engebretsen L, Laprade RF (2010) An in vitro analysis of an anatomical medial knee reconstruction. *Am. J. Sports Med.* 38:339–47
5. Cope MR, O'Brien BS, Nanu AM (2002) The influence of the posterior cruciate ligament in the maintenance of joint line in primary total knee arthroplasty: a radiologic study. *J Arthroplast.* 17:206–208
6. Cross MB, Nam D, Plaskos C, Sherman SL, Lyman S, Pearle AD, Mayman DJ (2012) Recutting the distal femur to increase maximal knee extension during TKA causes coronal plane laxity in mid-flexion. *Knee* 19:875–9
7. Van Damme G, Defoort K, Ducoulombier Y, Van Glabbeek F, Bellemans J, Victor J (2005) What should the surgeon aim for when performing computer-assisted total knee arthroplasty? *J. Bone Joint Surg. Am.* 87 Suppl 2:52–8
8. Ensini A, Catani F, Biasca N, Belvedere C, Giannini S, Leardini A (2012) Joint line is well restored when navigation surgery is performed for total knee arthroplasty. *Knee Surg. Sports Traumatol. Arthrosc.* 20:495–502
9. Feeley BT, Muller MS, Allen A a, Granchi CC, Pearle AD (2009) Isometry of medial collateral ligament reconstruction. *Knee Surg. Sports Traumatol. Arthrosc.* 17:1078–82
10. Hino K, Ishimaru M, Iseki Y, Watanabe S, Onishi Y, Miura H (2013) Mid-flexion laxity is greater after posterior-stabilised total knee replacement than with cruciate-retaining procedures: A computer navigation study. *Bone Joint J.* 95-B:493–7
11. Hofmann AA, Kurtin SM, Lyons S, Tanner AM, Bolognesi MP (2006) Clinical and radiographic analysis of accurate restoration of the joint line in revision total knee arthroplasty. *J. Arthroplasty* 21:1154–62
12. Howell SM, Howell SJ, Kuznik KT, Cohen J, Hull ML (2013) Does a kinematically aligned total knee arthroplasty restore function without failure regardless of alignment category? *Clin. Orthop. Relat. Res.* 471:1000–7
13. Hungerford DSS, Krackow KAA (1985) Total joint arthroplasty of the knee. *Clin Orthop Relat Res* 192:23–33
14. Hunt NC, Ghosh KM, Blain AP, Athwal KK, Rushton SP, Amis A a, Longstaff LM, Deehan DJ (2014) How does laxity after single radius total knee arthroplasty compare with the native knee? *J. Orthop. Res.* 32:1208–13
15. Incavo SJ, Schmid S, Sreenivas K, Ismaili S, Noble PC (2013) Total knee arthroplasty using anatomic alignment can produce mid-flexion laxity. *Clin. Biomech. (Bristol, Avon) Elsevier Ltd* 28:429–35
16. Insall JN, Binazzi R, Soudry M, Mestriner LA (1985) Total knee arthroplasty. *Clin. Orthop. Relat. Res.* 13–22
17. Kawamura H, Bourne RB (2001) Factors affecting range of flexion after total knee arthroplasty. *J Orthop Sci* 6:248–252
18. Kettelkamp DB, Johnson RJ, Smidt GL, Chao EY, Walker M (1970) An electrogoniometric study of knee motion in normal gait. *J. Bone Joint Surg. Am.* 52:775–90
19. Laubenthal KN, Smidt GL, Kettelkamp DB (1972) A quantitative analysis of knee motion during activities of daily living. *Phys. Ther.* 52:34–43
20. Luyckx T, Beckers L, Colyn W, Vandenuecker H, Bellemans J (2014) The adductor ratio: a new tool for joint line reconstruction in revision TKA. *Knee Surg. Sports Traumatol. Arthrosc.* 22:3028–33
21. Martin JW, Whiteside L a (1990) The influence of joint line position on knee stability after condylar knee arthroplasty. *Clin. Orthop. Relat. Res.* 259:146–56
22. Musahl V, Citak M, O'Loughlin PF, Choi D, Bedi A, Pearle AD (2010) The effect of medial versus lateral meniscectomy on the stability of the anterior cruciate ligament-deficient knee. *Am. J. Sports Med. American Orthopaedic Society for Sports Medicine* 38:1591–7

23. Nam D, Lin KM, Howell SM, Hull ML (2014) Femoral bone and cartilage wear is predictable at 0° and 90° in the osteoarthritic knee treated with total knee arthroplasty. *Knee Surg. Sports Traumatol. Arthrosc.*
24. Partington PF, Sawhney J, Rorabeck CH, Barrack RL, Moore J (1999) Joint line restoration after revision total knee arthroplasty. *Clin. Orthop. Relat. Res.* 367:165–71
25. Porteous a J, Hassaballa MA, Newman JH (2008) Does the joint line matter in revision total knee replacement? *J. Bone Joint Surg. Br. British Editorial Society of Bone and Joint Surgery* 90:879–84
26. Schroer WC, Berend KR, Lombardi A V, Barnes CL, Bolognesi MP, Berend ME, Ritter M a, Nunley RM (2013) Why are total knees failing today? Etiology of total knee revision in 2010 and 2011. *J. Arthroplasty Elsevier Inc.* 28:116–9
27. Shoji H, Solomonow M, Yoshino S, D'Ambrosia R, Dabezies E (1990) Factors affecting postoperative flexion in total knee arthroplasty. *Orthopedics* 13:643–649
28. Snider MG, Macdonald SJ (2009) The influence of the posterior cruciate ligament and component design on joint line position after primary total knee arthroplasty. *J. Arthroplasty Elsevier B.V.* 24:1093–8
29. Stoddard JE, Deehan DJ, Bull AMJ, McCaskie AW, Amis A a (2013) The kinematics and stability of single-radius versus multi-radius femoral components related to mid-range instability after TKA. *J. Orthop. Res.* 31:53–8
30. Yammine K (2013) Effect of partial medial meniscectomy on anterior tibial translation in stable knees: a prospective controlled study on 32 patients. *BMC Sports Sci. Med. Rehabil. BioMed Central* 5:17
31. Yoon J-R, Jeong H-I, Oh K-J, Yang J-H (2013) In vivo gap analysis in various knee flexion angles during navigation-assisted total knee arthroplasty. *J. Arthroplasty* 28:1796–800

## 3.4 DEVELOPMENT AND VALIDATION OF A GEOMETRICAL MODEL OF THE KNEE TO PREDICT THE EFFECT OF JOINT LINE CHANGES ON THE CORONAL PLANE STABILITY.

---

T Luyckx, J Victor

### 3.4.1 RATIONALE

The link between the level of the joint line and the coronal plane laxity was recognised by previous authors [3, 20]. Our experimental data in the previous paragraphs confirmed these findings and quantified the effect. In paragraph 3.2, it was shown that despite a well-balanced flexion and extension gap, raising the joint line significantly increased the strain in the medial collateral ligament in deep flexion. In paragraph 3.3, it was shown that despite a well-balanced flexion and extension gap, significant mid-flexion instability can occur if the level of the joint line is raised by a few millimetres. The explanation for the link between the level of the joint line and the joint stability is still lacking. It cannot be explained by the classic flexion/extension space paradigm as the instability occurred despite a well-balanced flexion and extension gap. In an attempt to provide a more profound insight in the association between the level of the medial joint line and joint stability, we developed a geometrical model of the knee.

### 3.4.2 DEVELOPMENT OF A GEOMETRICAL MODEL OF THE KNEE

The collaterals are recognised to be the primary joint stabilisers in the coronal plane and the concept of their isometry has been at the heart of models that describe normal knee motion [26]. Any form of instability in the coronal plane should therefore be brought back to the collateral ligaments. In order to predict the impact of changing the level of the medial joint line on the isometry of the superficial medial collateral ligament (sMCL), a simplified two-dimensional geometrical model was created. To be able to create such a model, some basic theorems have to be recognised.



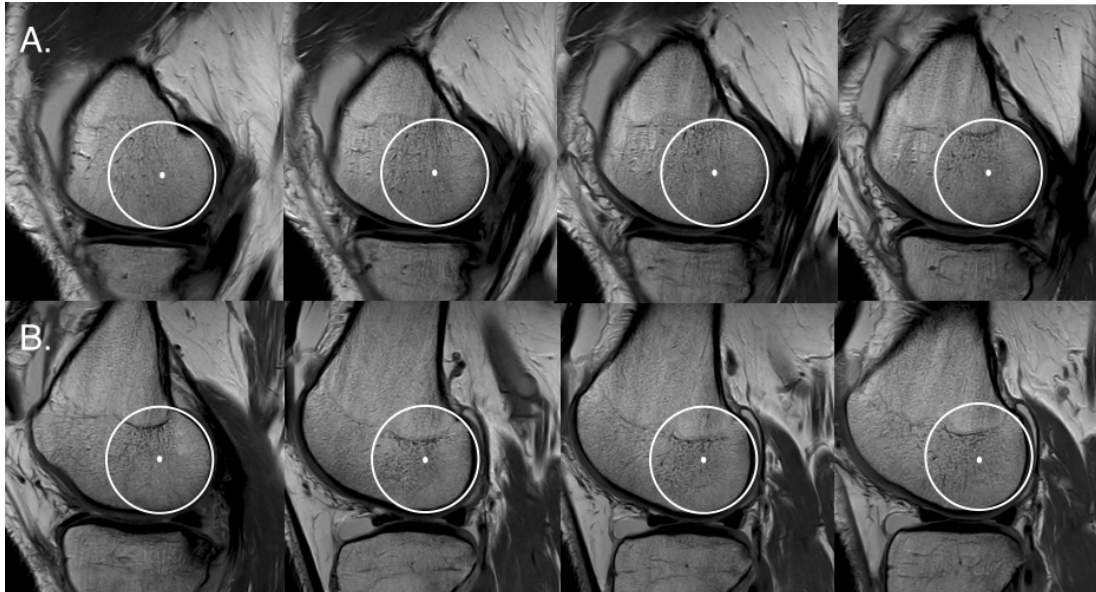
## *BASIC THEOREMS*

The **FIRST THEOREM** is that the sMCL is an isometric ligament, meaning that the change in length of its fibers during the range of motion is minimal. It's generally accepted that a ligament can be considered isometric if the strain in the flexion arc remains below 2% [26]. There is a lot of data to support this statement. First of all, we refer to our own data reported in paragraph 3.2.1 B. Using 3D DIC, we were able to show that the central part of the sMCL was almost perfectly isometric between 15° and 90°, showing less than 0.3% strain. During the whole range of motion the maximum change of length of the whole sMCL was still minimal, averaging 1.7%. These data are consistent with the work of others [9, 26]. Victor et al showed a change in length of the proximal sMCL of 1 mm between 0° and 90° of knee flexion [26]. Gosh et al found a change in length of on average 2 mm between 0° and 110° [9].

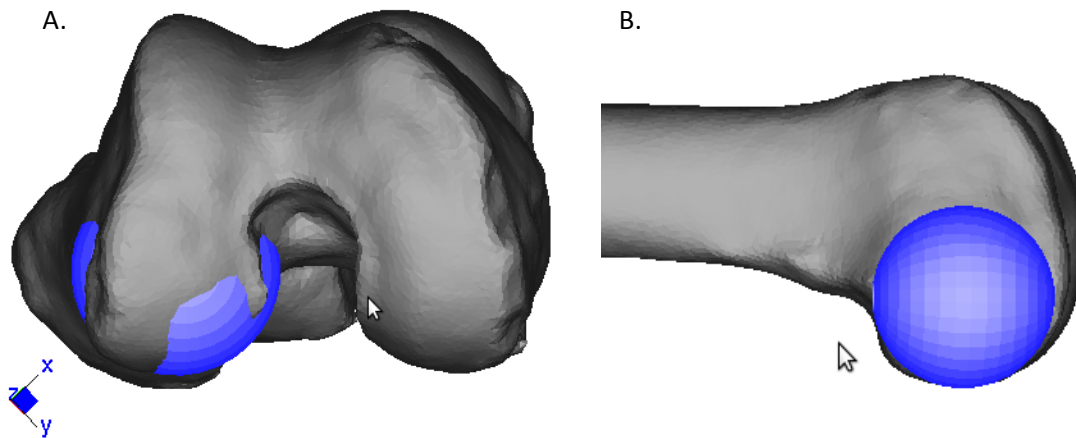
To be able to maintain its isometry throughout the range of motion, the femoral insertion site of the sMCL coincides with the flexion-extension axis of the knee [7, 13, 28]. If this were not the case, elongation or slackening would occur during the flexion arc [7]. As the superficial medial collateral ligament (sMCL) is the primary stabiliser against valgus stress, the concept of its isometry is crucial for knee stability as it reflects the ability of the ligament to stabilise the knee during the entire range of motion [10, 11, 19, 26].

This theorem might seem obvious and is based on sound evidence but some more complex computer models have failed to reproduce the sMCL elongation pattern of the native knee's [18]. Failure to reproduce the native isometry makes conclusions on the effect of joint line changes of such a model of little value.

The **SECOND THEOREM** is that from a morphological point of view, the shape of the posterior femoral condyles can be described as a circle. This goes back as far as 1836 when the Weber brothers were the first ones to describe the shape of the posterior condyles as a circle [29]. There are numerous more recent studies showing that with the use of sophisticated 3D imaging techniques, the shape of the femoral condyles can be described by best-fitting a circle, sphere or cylinder in the posterior medial and lateral condyle (fig 1 & 2) [2, 5, 6, 13, 14]. Achieving the best fit possible to the articular surface in the posterior condyles corresponds to a flexion range of 10° to 160° [6, 14, 29].



**Figure 1:** Sagittal MRI of a normal left knee. A best-fit circle to the subchondral-cancellous bone interface of the medial (A) and lateral (B) femoral condyle is shown. The radius of the circle was identical for all images.



**Figure 2:** 3D reconstruction image from a CT scan of the left knee. A sphere has been fit in the medial condyle in the axial plane (a) and the sagittal plane (b).

The **THIRD THEOREM** is that the knee flexes and extends around a fixed axis of rotation, located at the centre of these circular condyles.

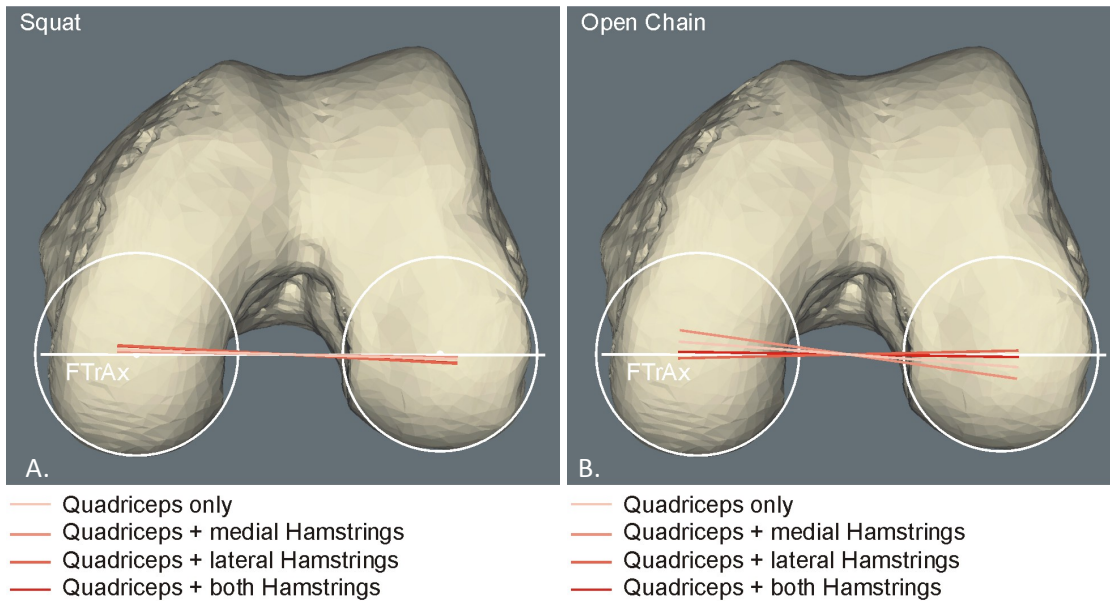
From a *kinematic point of view*, the knee was historically believed to rotate around a variable flexion-extension axis. Fick and others referred to it as a multi-radius curve with an “instant centre of rotation”, a theory that has been supported for almost 100 years [1, 8, 22, 27]. The problem created

here was attributable to looking at a circle off-axis. A circle that is viewed along a line other than its axis will appear as an ellipse, thus leading to the conclusion of a multi-radius curve [5]. Many recent kinematic studies have shown that the knee flexes with a fixed axis of rotation [2, 13].

As for the antero-posterior movement in the medial compartment, kinematic studies and in vivo weight-bearing MRI studies have shown that in contrast with the passive situation, there is very limited translation between 0° and 120° of knee flexion [5, 12, 16, 17, 24, 25]. External rotation of the tibia during flexion, allows the knee to function almost as a uniaxial hinge [12]. Therefore, kinematics of the medial femoral condyle can be described by a single and fixed centre of rotation in the sagittal plane between 0 and 120° of knee flexion.

Using a **surface derived approach** and 3D imaging, Howell and Eckhoff were able to show that the flexion-extension axis of the knee is fixed and passes through the centre point of a best-fit circle or cylinder in the posterior condyles [6, 14]. This assertion makes intuitive sense, as the axis is equidistant from the articular surface of the femur as it contacts the tibia from 15° to 115° of flexion [6]. If the flexion-extension axis of the knee lies at some other location, the surfaces would be pushed either together or apart at various points in the flexion arc. Furthermore, stretching and contracting of the ligaments must occur to a greater extent the farther the flexion axis lies from the point equidistant from the surface.

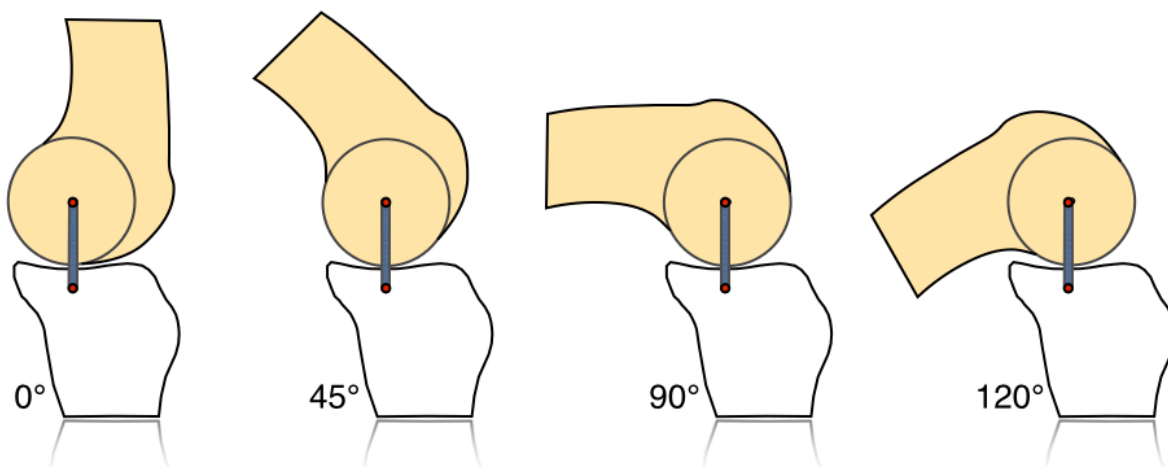
This is also consistent with our own unpublished work using a **combined approach**. We calculated the true flexion-extension axis of the knee using a kinematics-derived approach and compared it to a surface-derived axis. This surface-derived axis was created by best-fitting a sphere in the medial and lateral condyle and connecting the two centre points of the spheres. The flexion-extension axis from a kinematic point of view was calculated as previously described [25]. We found a considerable variation based on the type of motor task that was executed (open chain vs. closed chain) and the muscle load that was applied. However, when all muscle groups around the knee were loaded, the kinematic flexion-extension axis of the knee approached the surface-derived axis very closely (fig 3). Based on these findings, we concluded that the axis obtained from surface derived approach by best-fitting a sphere in the medial and lateral condyle closely approaches the kinematic flexion-extension axis of the knee during loaded knee motion.



**Figure 3:** Schematic representation of the projection of the true flexion-extension axis of the knee in the axial plane during a squat (a) and during an open chain movement (b). As all muscle groups around the knee are loaded, the flexion-extension axis closely approaches the central axis in the femoral condyles.

#### APPLICATION TO THE NATIVE KNEE

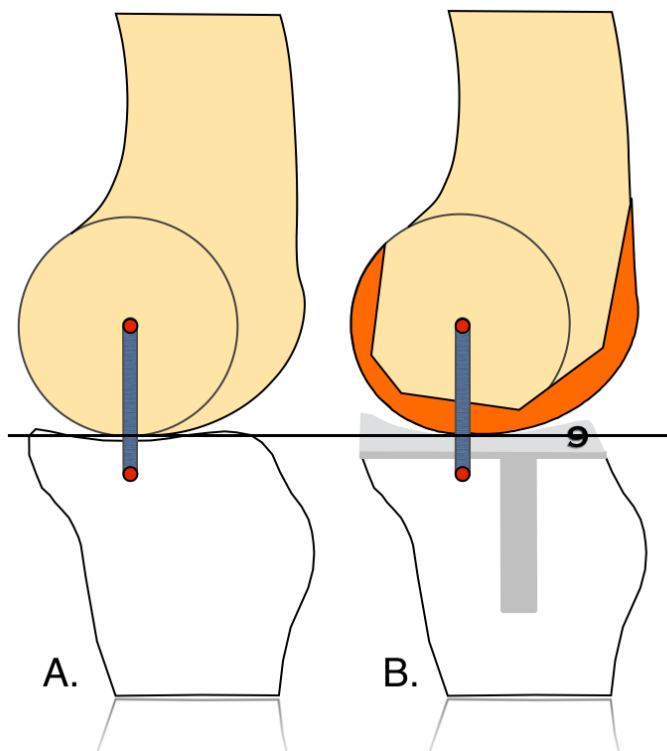
Based on these three theorems, we created a simplified geometrical model of the medial side of the knee in the sagittal plane. The sagittal cross section of the posterior medial condyle was represented as a circle. The centre of rotation throughout the range of motion was considered fixed and coincided with the centre of the circle. And the sMCL was considered isometric throughout the range of motion with its insertion site on the femur at the centre of rotation of the knee (fig 4).



**Figure 4:** Simplified geometrical model of the medial side of the native knee in the sagittal plane. A circle represents the curvature of the posterior medial condyle. The centre of this circle coincides with the centre of rotation and the femoral insertion site of the sMCL. During the range of motion, no change in length in the sMCL is observed.

*APPLICATION TO KNEE ARTHROPLASTY*

To restore both the natural strain and tension in the sMCL with TKA, a prosthesis with exact the same surface geometry (i.e. single radius) and size as the native knee should be used. This TKA should then be implanted with perfect restoration of the distal and posterior joint line. Doing so will restore the centre of rotation of the knee at its original spot and reproduce normal sMCL tension and thus joint stability (fig. 5b). This hypothesis was confirmed by the experimental work of Hunt et al. who showed that joint laxity under valgus/varus stress was comparable between the native knee and after implantation of a single radius TKA [15]. It was also confirmed by our work in paragraph 3.3 where we found that the normal joint laxity after single radius TKA was maintained when the medial joint line was restored at its original level. It is also supported by the work of Shimizu, who showed that after a single radius TKA, the medial side of the knee still moves with a stable centre of rotation with virtual no translation between 10° and 110° of flexion [21].



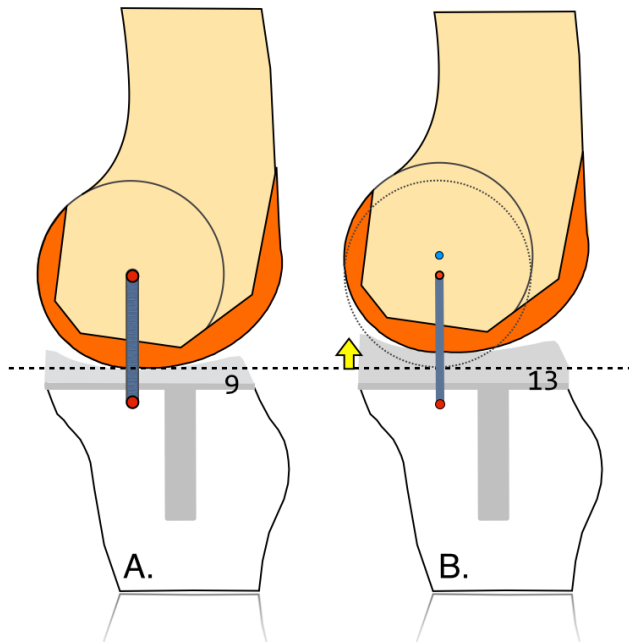
**Figure 5:** Geometrical model of the medial side of the knee representing the posterior medial condyle as a circle with the sMCL insertion site at the centre of this circle (a). A TKA with exact the same surface geometry (i.e. single radius) and size as the native knee restores the natural situation if the distal and posterior joint line are maintained at their original level (b).

### 3.4.3 PREDICTING THE EFFECT OF JOINT LINE CHANGES

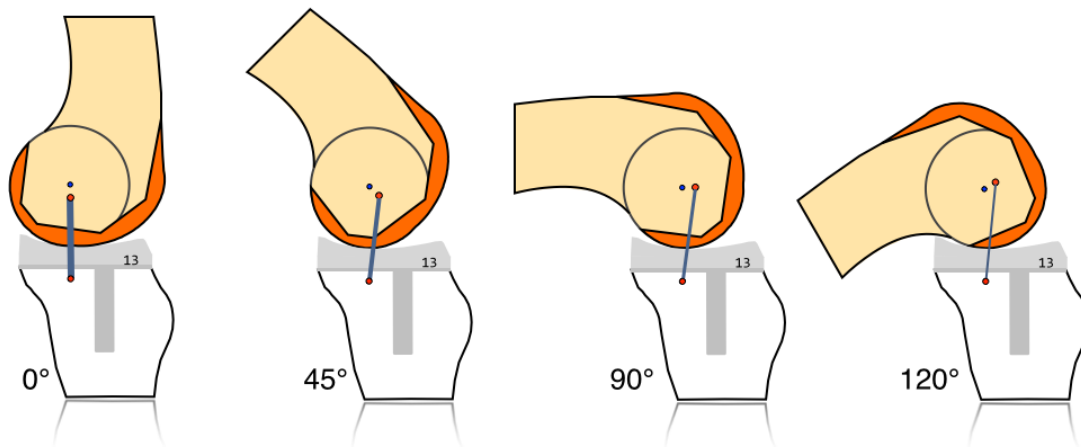
To be able to maintain its isometry during knee flexion, the sMCL inserts at the tibiofemoral centre of rotation [28]. Changes in joint line position with a TKA change the tibiofemoral centre of rotation from its original position (fig 6). As the femoral insertion site of the sMCL is not altered, it will pivot around the new centre of rotation during knee flexion and its isometric behaviour will be changed (fig 7) [19]. The precise effect on the length change of the sMCL depends on the direction of the joint line change. From the geometrical model, the length changes of the sMCL induced by changing the joint line were calculated.

#### *JOINT LINE ELEVATION*

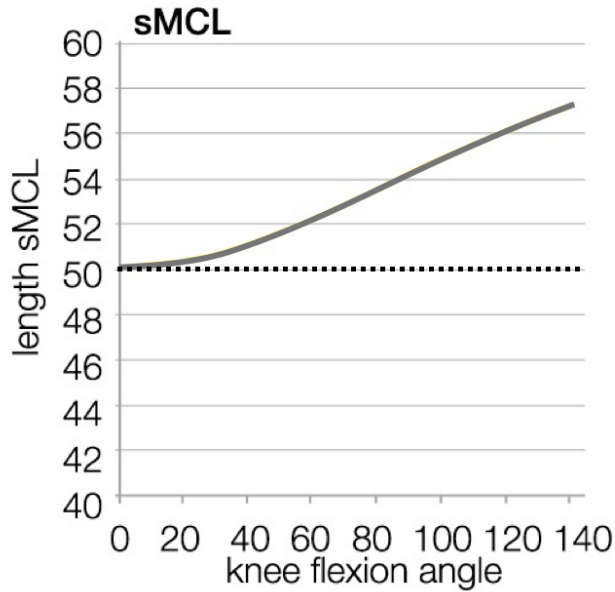
First, the effect of elevating the joint line by 4 mm was modelled. This was done by shifting the femoral component 4 mm proximal (fig 6). To maintain joint stability in extension, a 4 mm thicker insert is used. The proximal shift of the distal joint line will cause a 4 mm proximal shift of the tibiofemoral centre of rotation. The effect of this shift on the length of the sMCL is shown in figure 7 and 8. A progressive lengthening is expected with a maximum change in length of 7.2 mm at 140° of knee flexion. This observation is obvious and can also be explained by the flexion-extension gap theory. As only the extension space was enlarged by raising the joint line, the flexion space is too tight for the 4 mm thicker insert. According to our model, the length change will be mild in early flexion, and progress linearly from 40° to 140° of flexion.



**Figure 6:** Schematic representation of the effect of a **proximal shift** of the joint line on the sMCL isometry. A new centre of rotation (blue dot) is created due to the joint line shift. As the insertion site of the sMCL is unchanged (red dot), it will pivot around this new centre of rotation during the range of motion.



**Figure 7:** Schematic representation of the effect of a **proximal shift** of the joint line on the sMCL isometry. A new centre of rotation (blue dot) is created due to the joint line shift. As the insertion site of the sMCL is unchanged (red dot), it will pivot around this new centre of rotation during the range of motion. A proximal movement of the sMCL insertion site during the range of motion will cause progressive elongation of the sMCL.

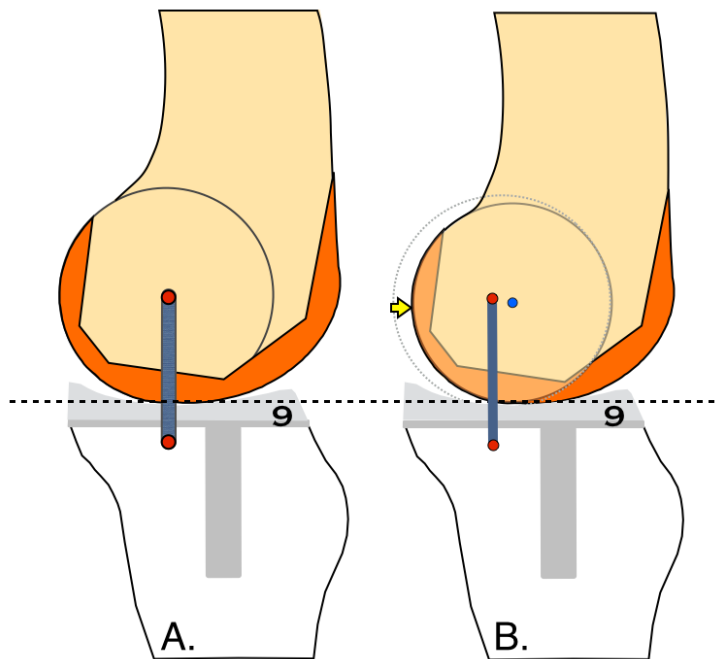


**Figure 8:** Graph plotting the sMCL length against the knee flexion based on the geometrical model. The dotted line represents the isometric sMCL with the native joint line. The grey line represents the change in length after a proximal shift of the joint line.

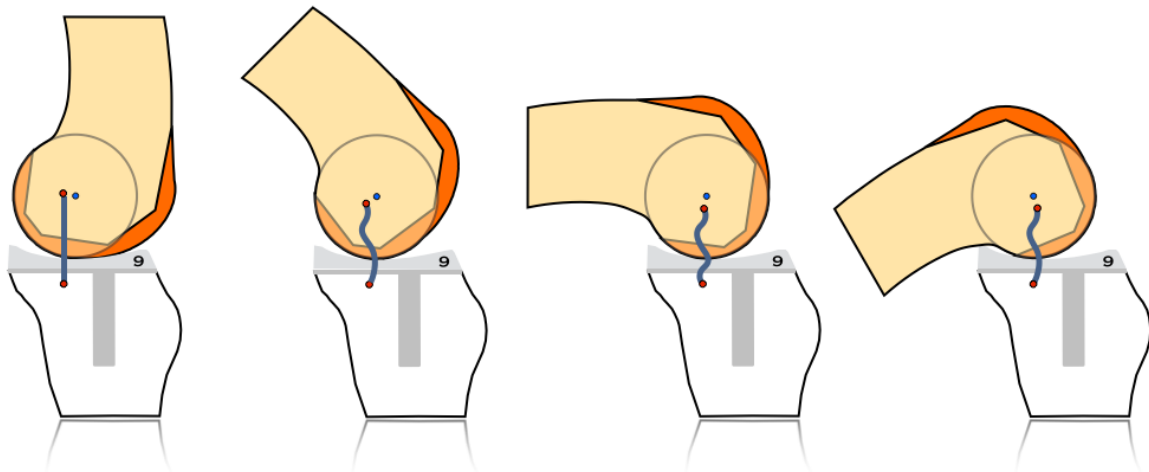
#### JOINT LINE ANTERIORISATION

Next, the effect of anteriorising the joint line by 4 mm was modelled. This was done by increasing the posterior resection with 4 mm and fitting a 4 mm smaller component on the same knee (fig 9). The anterior shift of the posterior joint line will cause a 4 mm anterior shift of the tibiofemoral centre of rotation. The effect of this shift on the length of the sMCL is shown in figure 10 and 11. A progressive slackening is predicted with a maximum change in length of 3.8 mm at 85° of knee flexion. This observation is again obvious and can also be explained by the flexion-extension gap theory. As only the flexion space is enlarged by anteriorising the joint line, the flexion space is too loose for the 4 mm thicker insert. According to our model, the length will progress linear from 0° to 70° of flexion. Between 70° and 100°, the length changes remain small. The sMCL is tensioned again towards deeper flexion. However, it never reaches its original length.

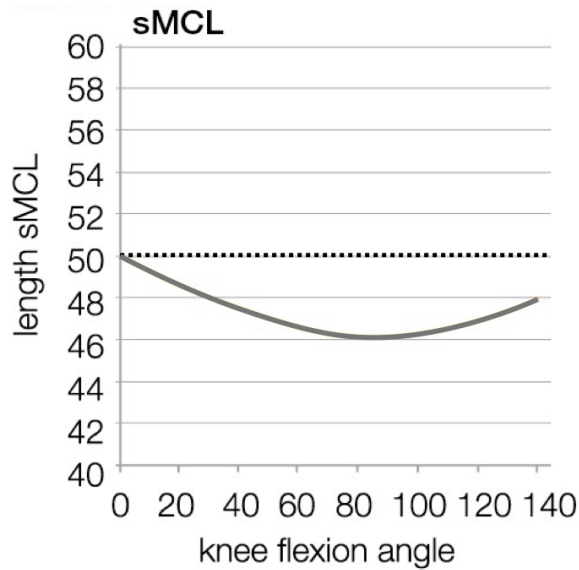




**Figure 9:** Schematic representation of the effect of an **anterior shift** of the joint line on the sMCL isometry. A new centre of rotation (blue dot) is created due to the joint line shift. As the insertion site of the sMCL is unchanged (red dot), it will pivot around this new centre of rotation during the range of motion.



**Figure 10:** Schematic representation of the effect of an **anterior shift** of the joint line on the sMCL isometry. A new centre of rotation (blue dot) is created due to the joint line shift. As the insertion site of the sMCL is unchanged (red dot), it will pivot around this new centre of rotation during the range of motion. A distal movement of the sMCL insertion site will cause laxity in mid-flexion and at 90°. In deep flexion, limited lengthening of the sMCL occurs due to a mild proximal shift of the insertion site.



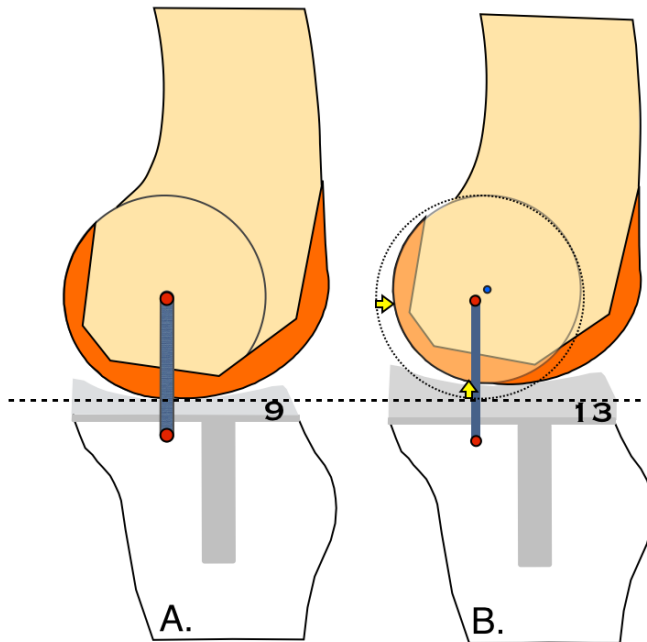
**Figure 11:** Graph plotting the sMCL length against the knee flexion based on the geometrical model. The dotted line represents the isometric sMCL with the native joint line. The grey line represents the change in length after an **anterior shift** of the joint line.

#### COMBINED ELEVATION AND ANTERIORISATION

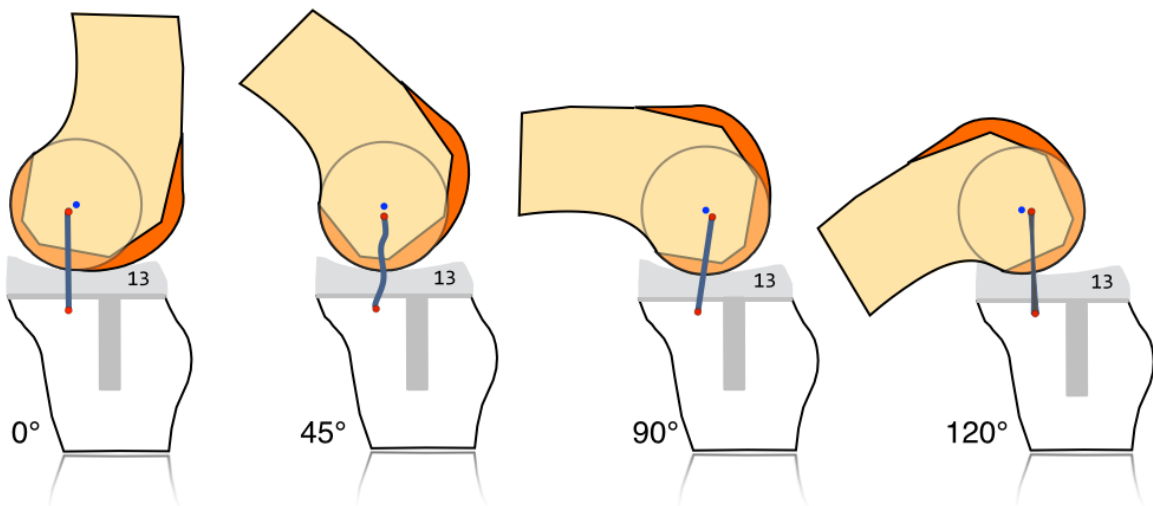
Next, the experimental setting of anteriorising and raising the joint line with 4 mm (TKA4) was modelled by fitting a 4 mm smaller femoral component in a 4 mm more proximal position on the same knee. Stability in flexion and extension was maintained by using a 4 mm thicker insert. As such, the joint line was raised by 4 mm (fig 12). The effect of this shift on the length of the sMCL is shown in figure 13 and 14. A progressive slackening is predicted in the mid-flexion range with a maximum slackening of 1.8 mm at 45° of knee flexion. At 90° an equal length as at 0° was predicted. And further elongation was observed in deeper flexion.

These observations cannot be explained by the flexion-extension gap paradigm, as flexion and extension gap were equal and balanced. However, our geometrical mode shows that the anterior and proximal shift of the joint line will cause a 4 mm anterior and proximal shift of the tibiofemoral centre of rotation. Consequently, a new centre of rotation will be defined (the blue dot) (fig 12b). The slackening in mid-flexion is a consequence of the fact that in mid-flexion, the sMCL insertion site was moved distally relative to the centre of rotation (fig 12). This is consistent with our data in previous chapters and is supported by the data of others [3, 20]. At 90° of flexion, an equal length as in the 0° position was shown. The knee would therefore be considered balanced by most surgeons. In deeper flexion, a proximal movement of the sMCL insertion site relative to the centre of rotation causes

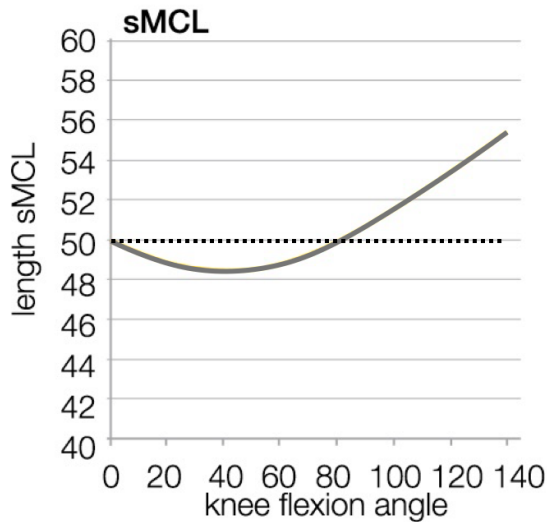
elongation. This is again consistent with our own data on strain in the sMCL after joint line elevation in paragraph 3.2.2 and is also consistent with the reports of others [7, 19, 30].



**Figure 12:** Schematic representation of the effect of a **proximal an anterior shift** of the joint line on the sMCL isometry. A new centre of rotation (bleu dot) is created due to the joint line shift. As the insertion site of the sMCL is unchanged (red dot), it will pivot around this new centre of rotation during the range of motion.



**Figure 13:** Schematic representation of the effect of a **proximal an anterior shift** of the joint line on the sMCL isometry. A new centre of rotation (bleu dot) is created due to the joint line shift. As the insertion site of the sMCL is unchanged (red dot), it will pivot around this new centre of rotation during the range of motion. A distal movement of the sMCL insertion site will cause laxity in mid-flexion. At 90°, equal length of the sMCL as in 0° is observed. The knee is therefore considered balanced. In deep flexion, progressive lengthening of the sMCL occurs due to a relative proximal shift of the insertion site.



**Figure 14:** Schematic representation of the effect of a proximal and anterior shift of the joint line on the length changes of the sMCL. The dotted line represents the isometric sMCL with the native joint line. The grey line represents the length change after a **proximal and anterior shift** of the joint line.

### 3.4.4 DISCUSSION

The value of our geometrical model is not in the prediction of absolute length changes of the sMCL caused by joint line changes but in providing a qualitative explanation for the effect that joint line changes have on sMCL isometry and thus joint stability. In contrast to the classic flexion-extension gap paradigm, it provides a new way of thinking on joint stability not only at 0 and 90° of knee flexion but throughout the whole range of motion.

The strength of the model is that, despite its simplicity, it is perfectly compatible with previous theories. As for the explanation for the observations done in the setting of the isolated elevation or isolated anteriorisation, the model is compatible with the classic flexion-extension gap thinking.

Second, it adds a new perspective to the understanding of joint stability by enabling the surgeon to predict the effect on knee stability not only at 0° and 90° of flexion but throughout the whole range of motion.

Third, it provides an explanation for the observations in our work in the previous chapters and in the work of others that previously could not be explained. If the joint line is raised and anteriorised by 4 mm, the flexion-extension gap theory would predict equal tension on the flexion and extension gap and thus a balanced knee. However, in an experimental setup we were able to show that raising the distal and posterior joint line in TKA introduced significant mid-flexion instability despite a well-

balanced flexion and extension gap (paragraph 3.3). Secondly, we were able to show that raising the distal and posterior joint line in TKA significantly increased the strain in the sMCL in deep flexion (paragraph 3.2). The model provides an explanation for these observations, based on the movement of the sMCL insertion site relative to the new centre of rotation (fig 13).

It can be considered validated as it showed perfect compatibility our own data. Furthermore, it is also perfectly compatible with other reports in literature on sMCL isometry, joint stability and the effect of joint line changes in TKA.

It becomes more and more clear that stability in the mid-flexion range is important for a good functional outcome. Our model adds to the understanding of the concept of joint stability by providing the surgeon a tool that can qualitatively predict what the effect of certain surgical decisions on joint stability throughout the range of motion will be.

Our model has several limitations. First of all, our model as every model is based on some theorems that are open to discussion. However, those theorems are widely supported in the literature and by our own data. Nevertheless, they should be kept in mind while interpreting these results. Predictions made by the model in the range of motion  $>120^\circ$  of flexion should be interpreted with caution for the same reason. Second, the tibiofemoral movement in the medial compartment is simplified and reduced to 2 dimensions. It does not account for the rotational movement that takes place in the axial plane near terminal extension and in deep flexion. Nevertheless, this rotation is limited between  $10^\circ$  and  $120^\circ$  of knee flexion. Because the centre of this rotation is also located in the medial condyle, the excursions on the medial side are small compared to the lateral side. Third, the model predicts length of the sMCL and not joint laxity. Whether the relationship between the sMCL length and the joint laxity is a linear one, still needs to be determined. The predictions that are made are therefore qualitative and not quantitative. Nevertheless, we were able to show that the relationship between the level of the medial joint line and the joint laxity is a linear one. Forth, it only takes into account the medial side of the knee. One can also expect an effect of the level of the lateral joint line on joint stability. However, our data in paragraph 3.3 showed that in a well-balanced knee, there was no effect of the level of the lateral joint line on knee joint stability. Fifth, the TKA modelled was as single radius design. The extend to which these findings can be applied to other TKA designs (i.e. dual radius, J-curve) depends on the difference in geometry in the sagittal plane between such a design and a single radius. The study of the geometry of different TKA designs in the sagittal plane is an exhaustive and difficult one. However, the difference between the different TKA designs is smaller then one would expect. Amis et al showed that the difference in contour in the sagittal plane between a single radius design and an old obsolete J curve design was 0 mm at  $0^\circ$  and

90° of flexion and 1.8 mm at 45° of flexion [23]. This difference would probably be even smaller with more recent J-curve designs. A 110% increase in joint laxity at 30° was observed by raising and anteriorising the joint line 4 mm. It is therefore unlikely that such a small difference of sagittal plane contour could eliminate the observed instability. We therefore believe that the effect will be similar with other TKA designs.

### 3.4.5 CONCLUSION

We are well aware of all the conceptual restrictions that are related to our model. Nevertheless, we believe that it is a simple and practical tool to predict the effect of distal and posterior joint line changes on sMCL isometry and joint stability. It adds a new perspective to the classic flexion/extension gap paradigm by enlightening the importance of maintaining the level of the medial joint line to joint stability and visualising the possibility of mid-flexion instability despite a well-balanced flexion and extension gap.

### 3.4.6 REFERENCES

1. Blankevoort L, Huiskes R, De Lange A (1990) Helical axes of passive knee joint motions. *J. Biomech.* 23:1219–1229
2. Churchill DL, Incavo SJ, Johnson CC, Beynnon BD (1998) The transepicondylar axis approximates the optimal flexion axis of the knee. *Clin Orthop Relat Res* 111–118
3. Cross MB, Nam D, Plaskos C, Sherman SL, Lyman S, Pearle AD, Mayman DJ (2012) Recutting the distal femur to increase maximal knee extension during TKA causes coronal plane laxity in mid-flexion. *Knee* 19:875–9
4. Van Damme G, Defoort K, Ducoulombier Y, Van Glabbeek F, Bellemans J, Victor J (2005) What should the surgeon aim for when performing computer-assisted total knee arthroplasty? *J. Bone Joint Surg. Am.* 87 Suppl 2:52–8
5. Eckhoff D, Hogan C, DiMatteo L, Robinson M, Bach J (2007) Difference between the epicondylar and cylindrical axis of the knee. *Clin Orthop Relat Res* 461:238–244
6. Eckhoff DG, Bach JM, Spitzer VM, Reinig KD, Bagur MM, Baldini TH, Flannery NMP (2005) Three-dimensional mechanics, kinematics, and morphology of the knee viewed in virtual reality. *J. Bone Joint Surg. Am.* 87 Suppl 2:71–80
7. Feeley BT, Muller MS, Allen A a, Granchi CC, Pearle AD (2009) Isometry of medial collateral ligament reconstruction. *Knee Surg. Sports Traumatol. Arthrosc.* 17:1078–82
8. Frankel VH, Burstein AH, Brooks DB (1971) Biomechanics of internal derangement of the knee. Pathomechanics as determined by analysis of the instant centers of motion. *J. Bone Joint Surg. Am.* 53:945–962
9. Ghosh KM, Merican AM, Iranpour F, Deehan DJ, Amis A a (2012) Length-change patterns of the collateral ligaments after total knee arthroplasty. *Knee Surg. Sports Traumatol. Arthrosc.* 20:1349–56

10. Griffith CJ, LaPrade RF, Johansen S, Armitage B, Wijdicks C, Engebretsen L (2009) Medial knee injury: Part 1, static function of the individual components of the main medial knee structures. *Am. J. Sports Med.* 37:1762–70
11. Grood E, Noyes F, Butler D, Suntay W (1981) Ligamentous and capsular restraints preventing straight medial and lateral laxity in intact human cadaver knees. *J. Bone Joint Surg. Am.* 63:1257
12. Hill PF, Vedi V, Williams A, Iwaki H, Pinskerova V, Freeman MA (2000) Tibiofemoral movement 2: the loaded and unloaded living knee studied by MRI. *J Bone Jt. Surg Br* 82:1196–1198
13. Hollister AM, Jatana S, Singh AK, Sullivan WW, Lupichuk AG (1993) The axes of rotation of the knee. *Clin Orthop Relat Res* 259–268
14. Howell SM, Howell SJ, Hull ML (2010) Assessment of the radii of the medial and lateral femoral condyles in varus and valgus knees with osteoarthritis. *J. Bone Joint Surg. Am.* 92:98–104
15. Hunt NC, Ghosh KM, Blain AP, Athwal KK, Rushton SP, Amis A a, Longstaff LM, Deehan DJ (2014) How does laxity after single radius total knee arthroplasty compare with the native knee? *J. Orthop. Res.* 32:1208–13
16. Iwaki H, Pinskerova V, Freeman MAR (2002) Tibiofemoral movement 1 : the shapes and the unloaded cadaver knee. *J. Bone Jt. Surg.* 82:0–6
17. Johal P, Williams A, Wragg P, Hunt D, Gedroyc W (2005) Tibio-femoral movement in the living knee. A study of weight bearing and non-weight bearing knee kinematics using “interventional” MRI. *J. Biomech.* 38:269–76
18. König C, Matziolis G, Sharenkov A, Taylor WR, Perka C, Duda GN, Heller MO (2011) Collateral ligament length change patterns after joint line elevation may not explain midflexion instability following TKA. *Med. Eng. Phys.* 33:1303–8
19. Luyckx T, Verstraete M, De Roo K, Dewaele W, Victor J, Bellemans J (2013) The Effect of Single Radius TKA Implantation and Joint Line Proximalisation on the Strain Pattern in the sMCL of the Knee. *Bone Jt. J. Orthop. Proc. Suppl. British Editorial Society of Bone and Joint Surgery* 95:401
20. Martin JW, Whiteside L a (1990) The influence of joint line position on knee stability after condylar knee arthroplasty. *Clin. Orthop. Relat. Res.* 259:146–56
21. Shimizu N, Tomita T, Yamazaki T, Yoshikawa H, Sugamoto K (2014) In vivo movement of femoral flexion axis of a single-radius total knee arthroplasty. *J. Arthroplasty Elsevier Inc.* 29:2407–11
22. Soudan K, Van Audekercke R, Martens M (1979) Methods, difficulties and inaccuracies in the study of human joint kinematics and pathokinematics by the instant axis concept. Example: the knee joint. *J. Biomech.* 12:27–33
23. Stoddard JE, Deehan DJ, Bull AMJ, McCaskie AW, Amis A a (2013) The kinematics and stability of single-radius versus multi-radius femoral components related to mid-range instability after TKA. *J. Orthop. Res.* 31:53–8
24. Victor J, Van Glabbeek F, Vander Sloten J, Parizel PM, Somville J, Bellemans J (2009) An experimental model for kinematic analysis of the knee. *J. Bone Joint Surg. Am.* 91 Suppl 6:150–63
25. Victor J, Labey L, Wong P, Innocenti B, Bellemans J (2010) The influence of muscle load on tibiofemoral knee kinematics. *J. Orthop. Res.* 28:419–28
26. Victor J, Wong P, Witvrouw E, Sloten J Vander, Bellemans J (2009) How isometric are the medial patellofemoral, superficial medial collateral, and lateral collateral ligaments of the knee? *Am. J. Sports Med.* 37:2028–36
27. Walker PS, Shoji H, Erkman MJ (1972) The rotational axis of the knee and its significance to prosthesis design. *Clin. Orthop. Relat. Res.* 89:160–70
28. Warren LA, Marshall JL, Girgis F (1974) The prime static stabilizer of the medial side of the knee. *J. Bone Joint Surg. Am.* 56:665–74
29. Weber W, Weber E (1836) *Mechanik der menschlichen Gehwerkzeuge. Eine anatomische-physiologische untersuchung.* Göttingen: Dieterich
30. Whiteside L, Summers R (1984) The effect of the level of the distal femoral resection on ligament balance in total knee arthroplasty. Annual Meeting knee Society Atlanta





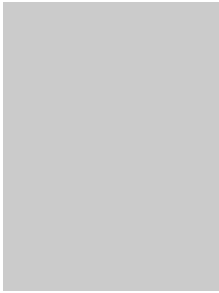
# **CHAPTER 4:**

# **THE JOINT LINE IN**

# **THE REPLACED KNEE**

---

**4**



# CHAPTER 4: CONTENTS

---

<b>4.1 The orientation of the tibio-femoral joint line in the axial plane</b>	<b>165</b>
<b>4.2 The orientation of the tibio-femoral joint line in the coronal plane</b>	<b>176</b>
<i>4.2.1 The effect of joint line orientation on alignment after TKA</i>	176
<i>4.2.2 The effect of joint line orientation on clinical outcome after TKA</i>	187

# CHAPTER 4: THE TIBIO-FEMORAL JOINT LINE IN THE REPLACED KNEE

---

## 4.1 THE ORIENTATION OF THE TIBIO-FEMORAL JOINT LINE IN THE AXIAL PLANE

**T Luyckx, T Peeters, H Vandenneucker, J Victor, J Bellemans.**

Is adapted measured resection superior to gap-balancing in determining femoral component rotation in TKA? *J Bone Joint Surg [Br]* 2012;94:1271–6.

Winner of the Young Researcher Award at the 15th ESSKA conference, 2012, Geneva

### ABSTRACT

Obtaining a balanced flexion gap with correct femoral component rotation is one of the prerequisites for a successful outcome after total knee replacement (TKR). Different techniques for achieving this have been described. In this study we prospectively compared gap-balancing *versus* measured resection in terms of reliability and accuracy for femoral component rotation in 96 primary TKRs performed in 96 patients using the Journey system. In 48 patients (18 men and 30 women) with a mean age of 65 years (45 to 85) a tensor device was used to determine rotation. In the second group of 48 patients (14 men and 34 women) with a mean age of 64 years (41 to 86), an ‘adapted’ measured resection technique was used, taking into account the native rotational geometry of the femur as measured on a pre-operative CT scan.

Both groups systematically reproduced a similar external rotation of the femoral component relative to the surgical transepicondylar axis: 2.4° (SD 2.5) in the gap-balancing group and 1.7° (SD 2.1) in the measured resection group ( $p = 0.134$ ). Both gap-balancing and adapted measured resection techniques proved equally reliable and accurate in determining femoral component rotation after TKR. There was a tendency towards more external rotation in the gap-balancing group, but this difference was not statistically significant. The number of outliers for our ‘adapted’ measured resection technique was much lower than reported in the literature.

## INTRODUCTION

Correct rotational alignment of the femoral component is believed to be a prerequisite for a successful outcome after total knee replacement (TKR). Rotation of the femoral component affects stability in flexion, tibiofemoral and patellofemoral kinematics, and alignment in flexion [1-4]. The rotational alignment of the femoral component can be determined in different ways.

In the gap-balancing technique, the surgeon performs ligamentous releases to balance the knee in extension after performing the femoral and tibial cuts. This is followed by resection of the posterior femoral surfaces parallel to the prepared cut tibial surface, by applying equal loads to the medial and lateral compartments [5,6]. In the measured resection technique, a surface-derived reference axis of the femur is used as a guide to determine the position of the femoral component in the axial plane. Several different reference axes derived from the bony landmarks have been introduced, of which the posterior condylar line (PCL) [7,8], the surgical transepicondylar axis (sTEA) [2,9,10], the anatomical transepicondylar axis (aTEA) [11,12], and the trochlear anteroposterior axis (TRAx) [13,14] are the most popular. Debate concerning the superiority of one technique over another in obtaining the 'correct' femoral component rotational alignment continues.

In this study we prospectively compared the rotational alignment of the femoral component obtained by a gap-balancing technique in one group and a measured resection technique in the other. We hypothesised that there would be a difference between the two groups in terms of rotational alignment of the femoral component.

## PATIENTS AND METHODS

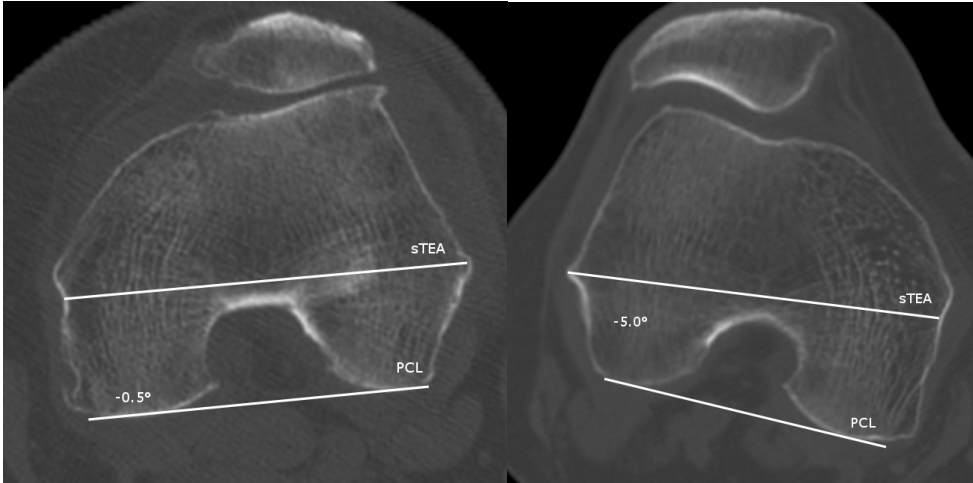
We studied 96 consecutive patients with osteoarthritis who underwent a primary posterior cruciate-substituting TKR (Journey; Smith & Nephew Inc., Andover, Massachusetts) between November 2005 and April 2008. Pre-operative findings and demographic characteristics were recorded for all patients.

The study was performed prospectively in two consecutive series. All surgery was performed by one of the senior authors (JB) in a standardised fashion, using a mid-vastus approach. The femoral resection was undertaken first in all patients. The distal femur was resected with a valgus angle of 4° to 6°, which was determined from the valgus angle measured on the pre-operative full-leg standing radiograph. In the first 48 knees, which formed the gap-balancing group, the tibial coronal cut was

then undertaken. A tensor was inserted in extension and ligamentous releases were performed where needed to balance the knee. Subsequently, anterior and posterior femoral resections were guided by a central spreading tensor (Journey, Smith & Nephew) by applying equal loads on the medial and lateral compartments (Fig. 1). In the next 48 knees, referred to as the measured resection group, the rotation of the femoral component was guided primarily by the posterior condyles. With traditional measured resection, surgeons adapt the rotation of the femoral component using a surface-derived reference frame located intra-operatively. However, at our institution the external rotation dictated by the PCL is adapted according to the native rotational geometry of the distal femur using the pre-operative CT scan (Fig. 2). Using the instrumentation system without adaptation results in a 3° external rotation of the femoral cutting block relative to the PCL. When a 5° internal rotation of the PCL relative to the epicondylar axis of the native femur is measured on pre-operative CT scans, for instance, we would externally rotate our cutting block by an additional 2° by placing the appropriate shim under the lateral condyle, to obtain a 5° external rotation in total (fig2b). For small values the appropriate shim would be inserted under the medial condyle.



**Figure 1:** Photograph showing the use of the tensor device with a central spreader to determine the rotation of the femoral component.

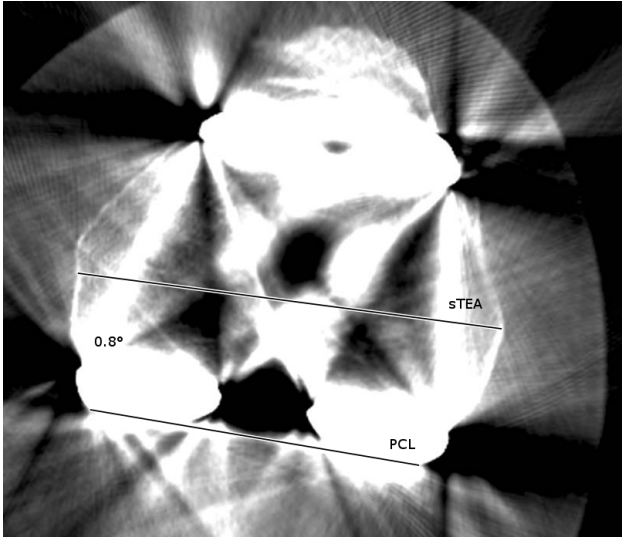


**Figure 2:** Measurement of the native posterior condylar angle (PCA) on the axial CT scan in (a) a left knee of a patient with varus alignment of  $8^\circ$  and a PCA of  $-0.5^\circ$ , and (b) a right knee of a patient with a valgus alignment of  $9^\circ$  and a PCA of  $-5.0^\circ$ . sTEA = surgical transepicondylar axis; PCL = posterior condylar line.

Standard standing antero-posterior (AP), lateral and long leg radiographs, and a CT scan, were obtained of all knees pre- and post-operatively as part of a standard TKR protocol. The weight-bearing full-leg radiographs, which included the whole pelvis, were obtained with the patient standing while ensuring that the patellae were oriented forwards, as described elsewhere.<sup>15</sup> The radiographs were calibrated and all measurements performed using the AGFA Picture Archive and Communication System (PACS) (Agfa-Gevaert, Mortsel, Belgium). All CT scans were performed with the use of a scatter reduction protocol and a slice thickness of 2 mm. The pre-operative CT scan only included the distal femur, but post-operatively it included both distal femur and proximal tibia.

On the pre- and post-operative full-leg radiographs, the mechanical femoral axis was defined as the line from the centre of the femoral head to the deepest point of the intercondylar notch. The line from the mid-point of the tibial spine to the centre of the talus was defined as the mechanical tibial axis. The pre- and post-operative mechanical alignment, as defined by the angle between the mechanical axis of the femur and the mechanical axis of the tibia, was measured in all patients. Varus was denoted as a negative value, valgus as positive.

Rotation of the femoral component was determined on the axial post-operative CT images. The angle between the sTEA and the PCL was measured (Fig. 3) and was termed the posterior condylar angle (PCA). The sTEA was defined as a line drawn on the axial CT scan through the lowest point of the sulcus (a little proximal and posterior to the medial epicondyle, as described by LaPrade et al [16] on the medial side and the highest point on the lateral epicondyle. Internal rotation of the PCL relative to the sTEA was denoted as a negative value, external rotation as a positive value.



**Figure 3:** Axial CT scan showing the measurement of femoral component rotation using a scatter reduction protocol. In this typical example the rotation of the femoral component relative to the surgical transepicondylar axis (sTEA) was 0.8° (PCL = posterior condylar line).

All measurements were performed twice by three independent observers. For all 96 cases, the need for per-operative soft tissue releases was noted for each patient as well as the type of release (superficial medial collateral ligament, deep medial collateral ligament, posteromedial capsule, ileotibial band, lateral retinaculum, popliteus tendon, lateral collateral ligament).

#### Statistical analysis

An a priori power analysis showed that to detect a rotational difference of 3°, which was considered ‘clinically relevant’, the power of the current study exceeded 99.9% ( $\alpha = 0.05$ ,  $\beta = 0.01$ ) with 48 patients in both arms of the study. An a posteriori power analysis showed 80% power to detect a rotational difference of 1.35° between the two groups ( $\alpha = 0.05$ ,  $\beta = 0.2$ ).

The intra- and inter-observer reproducibility of the measurement of femoral rotation was quantified by appropriate variance components, obtained from a linear mixed model for the six repeated measures of rotation (three observers, two replications per observer). The mixed model is fitted with the SAS-procedure PROC MIXED using REML estimation. Bland–Altman plots were used to analyse the intra- and inter-observer agreement. Spearman’s correlations were used to explore the relationships between continuous variables. Multiple regression models with the mean (i.e. mean over the six repeated measures) femoral rotation as response were used to verify whether the relationship between femoral rotation and another continuous variable, such as pre-operative varus/valgus axis, differed between the bone referencing and the tensor groups. Fisher’s exact tests were used to compare the proportion of each type of release in the two groups. The number of

releases was also compared between the groups using a trend test. Based on the mixed model (using ML estimation) there is no significant difference in femur rotation between both groups ( $p=0.13$ ). This is confirmed by the non-parametric Mann-Whitney U test ( $p=0.13$ ) comparing the mean (over the six repetitions) between both groups. The same procedure was repeated for the other alignment measurements (coronal pre- and postoperative, rotational pre-operative) with a Mann-Whitney U test. All analyses were performed using SAS version 9.1 (SAS Institute, Cary, North Carolina).  $p$ -values were two-sided and considered significant if  $p < 0.05$ .

## RESULTS

The demographic parameters of the two groups are listed in Table I. No statistical significant differences were noted. The difference in mean femoral component rotation between the gap balancing and measured resection methods was  $0.7^\circ$  ( $p = 0.13$ ). Also, the variability (SD 2.1 vs 2.5) and the number of outliers between the two groups were not statistically different ( $p = 0.23$ ). In the gap-balancing group the post-operative PCL was a mean of  $3.2^\circ$  externally rotated compared to the pre-operative situation, and in the measured resection group it was  $2.9^\circ$  (Table I).

	Gap-balancing	Measured resection	p-value
Number of knees	48	48	
Male:female ratio	18:30	14:34	0.39*
Mean age (yrs) (range)	65 (45 to 85)	64 (41 to 86)	0.73†
Mean coronal alignment ( $^\circ$ )			
Pre-operative (range [SD])	-4.7 (14.9 varus to 16 valgus) [7.0]	-3.7 (19.7 varus to 12.4 valgus) [7.4]	0.47‡
Post-operative [SD]	-1.2 (3.0)	-0.72 (3.5)	0.50‡
Mean rotational alignment ( $^\circ$ )			
Pre-operative (range [SD])	-0.8 (-5.3 to 3.3) [1.8]	-1.2 (-5.8 to 3.2) [2.1]	0.14‡
Post-operative (range [SD])	2.4 (-2.8 to 6.9) [2.5]	1.7 (-2.5 to 6.5) [2.1]	0.13‡
Difference pre- vs post-operative	3.1	2.9	0.36‡

\* chi-squared test

† unpaired two-sided Student's  $t$ -test

‡ non-parametric Mann-Whitney U test

**Table I.** Demographic data and alignment measurements of the two groups. There were no significant differences between the two groups.

The interobserver variability for the femoral component rotational measurements was  $1.7^\circ$  and the intra-observer variability was  $1.0^\circ$ . All intraclass correlation coefficients (ICC) for inter- and intra-observer measurements were  $> 0.75$ , indicating a good agreement.

In the gap-balancing group there was a clear correlation with the pre-operative rotational geometry of the distal femur ( $R = 0.45$ ;  $p < 0.001$ ), and no significant correlation with the pre-operative coronal alignment ( $R = -0.03$ ;  $p = 0.82$ ) (Fig. 3). In the measured resection group, Spearman's correlation coefficient ( $R$ ) showed a stronger correlation between femoral component rotation and pre-



operative coronal alignment ( $R = -0.37$ ;  $p = 0.011$ ). Secondly, Spearman's correlation coefficient showed a strong correlation between femoral component rotation and the pre-operative rotational geometry of the distal femur ( $R = 0.63$ ,  $p < 0.001$ ). When the correlation between the two groups and the pre-operative alignment (both rotational and coronal) was verified, the relationship between the femoral component rotation and the pre-operative alignment was clear but not significantly different between the groups ( $p = 0.26$ ).

For none of the ligamentous releases was there any statistical evidence that the proportion of knees requiring releases differed between the two groups, nor was there for the number of any specific type of release (Fisher's exact test,  $p = 0.19$  and  $p = 0.53$ , respectively).

## DISCUSSION

There seems to be much confusion about the concept of 'rotation' of the femoral component. In fact, rotation of the femoral component should be considered an adapted and unnatural situation which arises because the transverse knee axis makes a mean angle of  $87^\circ$  with the mechanical axis of the tibia.<sup>17</sup> A coronal tibial cut perpendicular to the mechanical axis of the tibia will produce a  $3^\circ$  asymmetrical resection of the tibia, which is compensated by a  $3^\circ$  asymmetrical resection of the distal femur to obtain neutral alignment. The same is true for the posterior condyles [18]. The asymmetrical tibial resection will result in a trapezoidal flexion space, which will be larger laterally. A  $3^\circ$  external rotation of the femoral component is therefore recommended by some to compensate for the lateral over-resection of the tibia [19]. This rotational adaptation is the main determinant of ligament balance in flexion, load distribution in flexion, and the patellofemoral and tibiofemoral kinematics. When trying to define how rotational alignment of the femoral component can best be performed, one must first ask, what is the optimal rotational alignment of the distal femur? A literature review performed by one of the authors (JV) has shown that in the native knee the PCL is generally  $3^\circ$  internally rotated relative to the sTEA and  $5^\circ$  internally rotated relative to the aTEA [20]. However, there was considerable variation in these values. This is the primary problem of a classic measured resection technique: inter-individual inconsistency of the reference axis. This has led some authors to conclude that bony landmarks are unreliable in determining the optimal rotational position of the femoral component and should be considered an out-dated technique [21]. However, part of the rotational variation of the native knee can be explained by the correlation between the coronal alignment and the rotational geometry of the distal femur. It has long been known that the rotational geometry differs between valgus knees and neutral or varus knees [9]. More recently, Aglietti et al [22] found a linear relationship between the PCA and coronal alignment. A  $1^\circ$  PCA

increment was observed with every 10° increment of coronal deformity from varus to valgus. Taking this association into account can significantly increase the precision of determining femoral component rotation using bony landmarks.

The second major problem with the classic measured resection technique is surgical inconsistency in locating the reference axis intra-operatively. This accounts for the wide range of post-operative rotational positions of the femoral component reported in the literature for this method [21,23,24]. When interpreting these data, differences in the reference axis used to describe the rotational position must also be considered. Dennis, using a measured resection technique and the aTEA as a reference, reported a mean external rotation of the femoral component of 0.9° (-12° to 16°) [21]. When the posterior condylar axis was used, the femoral component was positioned at a mean of 0.4° internally rotated (15° internal rotation to 13° external) compared to gap-balancing. The use of the anteroposterior axis resulted in a mean femoral component rotation of 1.9° (13° internal rotation to 18° external). Schnurr, Nessler and Konig, using navigation and the PCL as a reference, reported mean rotational values of the femoral component of 4.4° (-11.5° to 11.8°) [23]. On post-operative CT scans, Stockl et al measured a mean internal rotation of the femoral component of 2.52° relative to the aTEA, using a measured resection technique with a fixed 3° of external rotation [24]. The standard deviation (SD) was as high as 6.77°. Using measured resection with computer-assisted surgery, the mean internal rotation was 1.7° and SD was reduced to 3.27°. Nevertheless, gap-balancing techniques have also been associated with a wide variation in femoral component rotation. Heesterbeek, Jacobs and Wymenga et al measured intra-operative femoral component rotation, and relative to the posterior condyles they found values ranging from -4° to 13° [25,26].

Proponents of gap-balancing state that they are able to obtain a balanced flexion gap in more cases than with classic measured resection. However, one theoretical problem with gap-balancing is that it does not take into account the natural laxity on the lateral side of the knee [27,28]. Applying equal tension to the medial and lateral collateral ligaments will cause more joint space opening on the lateral side, thereby creating a balanced but more externally rotated flexion gap. This is consistent with our findings of a tendency towards more external rotation of the femoral component using gap balancing, and is consistent with the findings of others [25]. This external rotation will cause the knee to shift to varus in flexion, causing overload on the medial side in flexion [4]. Excessive external rotation also has a negative effect on tibiofemoral and patellofemoral kinematics [1].

All our patients underwent pre-operative CT scanning of the distal femur to determine the native PCA. Using a PCL referencing technique, the PCA value is used intra-operatively to compensate for an eventual deviation. We termed this technique 'adapted measured resection'. In this way, the

rotational adaptation of the femoral component is tailored to the patient's original anatomy and the two major inconsistencies of inter-individual and surgical variation of the classic measured resection are avoided. In practice, this means that for valgus knees  $> 3^\circ$  of external rotation is often needed (Fig. 1). In a severe varus knee  $< 3^\circ$  of external rotation is often used (Fig. 1). The results of our 'adapted' measured resection show a much more consistent rotation of the femoral component with a smaller range and smaller SD than those reported in the literature with classically measured resection. We believe this is due to the additional rotational adaptation based on the native rotational geometry of the distal femur using the pre-operative CT scan.

Our study has several limitations. First, rotational measurements on CT scans are subject to measurement error. We tried to reduce this error by taking the measurements twice using three independent observers. Second, our 'adapted' measured resection requires a pre-operative CT scan, which increases expenditure and exposure to radiation. If the technique succeeds in reducing the number of revisions for flexion instability, this increased expense could be justified. However, this hypothesis needs further investigation.

Our study had a power of  $> 99.9\%$  for detecting a clinically relevant difference of  $3^\circ$  of femoral component rotation between the two groups. However, we identified no significant difference in rotational position in the axial plane of the femoral component between our 'adapted' measured resection and the gap-balancing group. Both groups showed an acceptable mean external rotation of the femoral component, with  $1.7^\circ$  external rotation in the PCL referencing group and  $2.4^\circ$  external rotation in the gap-balancing group. There was a tendency toward more external rotation in the gap-balancing group, but regression analysis was not able to confirm this tendency. Interestingly, in the measured resection group the Spearman's correlation coefficient showed a correlation between femoral component rotation on the one side and pre-operative coronal alignment ( $R = -0.37$ ;  $p = 0.01$ ) and the pre-operative rotational geometry of the distal femur ( $R = 0.63$ ;  $p < 0.001$ ) on the other side. Knowing that there is a relationship between coronal and rotational alignment in the native knee, as previously discussed, and using the PCL as a bony reference, this is to be expected. In the gap-balancing group, on the other hand, there is a clear but less strong correlation with the pre-operative rotational geometry of the distal femur ( $R = 0.45$ ;  $p < 0.001$ ) and no significant correlation with pre-operative alignment (Fig. 3), so the gap-balancing technique seemed less dependent on the pre-operative coronal alignment. However, when the interaction between the two groups and the pre-operative alignment was verified, the relationship between femoral rotation and pre-operative alignment was not significantly different between the two groups ( $p = 0.26$ ).

Knowing, understanding and taking into account the native rotational geometry of the knee is a prerequisite for correct positioning of the femoral component in the axial plane. More research is needed to define this range of individual variation and its determinants. A thorough understanding of these factors will contribute to better femoral component positioning in TKR.

## REFERENCES

1. Merican AM, Ghosh KM, Iranpour F, Deehan DJ, Amis AA. The effect of femoral component rotation on the kinematics of the tibiofemoral and patellofemoral joints after total knee arthroplasty. *Knee Surg Sports Traumatol Arthrosc* 2011;19:1479-87.
2. Berger RA, Rubash HE, Seel MJ, Thompson WH, Crossett LS. Determining the rotational alignment of the femoral component in total knee arthroplasty using the epicondylar axis. *Clin Orthop Relat Res* 1993;286:40-7.
3. Akagi M, Matsusue Y, Mata T, et al. Effect of rotational alignment on patellar tracking in total knee arthroplasty. *Clin Orthop Relat Res* 1999;366:155-63.
4. Hanada H, Whiteside LA, Steiger J, Dyer P, Naito M. Bone landmarks are more reliable than tensioned gaps in TKA component alignment. *Clin Orthop Relat Res* 2007;462:137-42.
5. Freeman MA, Todd RC, Bamert P, Day WH. ICLH arthroplasty of the knee: 1968-1977. *J Bone Joint Surg [Br]* 1978;60-B:339-44.
6. Scuderi GR, Insall JN. The posterior stabilized knee prosthesis. *Orthop Clin North Am* 1989;20:71-8.
7. Laskin RS. Flexion space configuration in total knee arthroplasty. *J Arthroplasty* 1995;10:657-60.
8. Hungerford DS, Kenna RV. Preliminary experience with a total knee prosthesis with porous coating used without cement. *Clin Orthop Relat Res* 1983;176:95-107.
9. Griffin FM, Insall JN, Scuderi GR. The posterior condylar angle in osteoarthritic knees. *J Arthroplasty* 1998;13:812-15.
10. Asano T, Akagi M, Nakamura T. The functional flexion-extension axis of the knee corresponds to the surgical epicondylar axis: in vivo analysis using a biplanar image-matching technique. *J Arthroplasty* 2005;20:1060-7.
11. Poilvache PL, Insall JN, Scuderi GR, Font-Rodriguez DE. Rotational landmarks and sizing of the distal femur in total knee arthroplasty. *Clin Orthop Relat Res* 1996;331:35-46.
12. Yoshioka Y, Siu D, Cooke TD. The anatomy and functional axes of the femur. *J Bone Joint Surg [Am]* 1987;69-A:873-80.
13. Arima J, Whiteside LA, McCarthy DS, White SE. Femoral rotational alignment, based on the anteroposterior axis, in total knee arthroplasty in a valgus knee: a technical note. *J Bone Joint Surg [Am]* 1995;77-A:1331-4.
14. Whiteside LA, Arima J. The anteroposterior axis for femoral rotational alignment in valgus total knee arthroplasty. *Clin Orthop Relat Res* 1995;321:168-72.
15. Bellemans J, Colyn W, Vandenneucker H, Victor J. The Chitranjan Ranawat award: is neutral mechanical alignment normal for all patients? The concept of constitutional varus. *Clin Orthop Relat Res* 2012;470:45-53.
16. LaPrade RF, Engebretsen AH, Ly TV, et al. The anatomy of the medial part of the knee. *J Bone Joint Surg [Am]* 2007;89-A:2000-10.
17. Moreland JR, Bassett LW, Hanker GJ. Radiographic analysis of the axial alignment of the lower extremity. *J Bone Joint Surg [Am]* 1987;69-A:745-9.
18. Romero J, Duronio JF, Sohrabi A, et al. Varus and valgus flexion laxity of total knee alignment methods in loaded cadaveric knees. *Clin Orthop Relat Res* 2002;394:243-53.
19. Worland RL, Jessup DE, Vazquez-Vela Johnson G, et al. The effect of femoral component rotation and asymmetry in total knee replacements. *Orthopedics* 2002;25:1045-8.
20. Victor J. Rotational alignment of the distal femur: a literature review. *Orthop Traumatol Surg Res* 2009;95:365-72.

21. Dennis DA. Measured resection: an outdated technique in total knee arthroplasty. *Orthopedics* 2008;31:940-4.
22. Aglietti P, Sensi L, Cuomo P, Ciardullo A. Rotational position of femoral and tibial components in TKA using the femoral transepicondylar axis. *Clin Orthop Relat Res* 2008;466:2751-5.
23. Schnurr C, Nessler J, König DP. Is referencing the posterior condyles sufficient to achieve a rectangular flexion gap in total knee arthroplasty? *Int Orthop* 2009;33:1561-5.
24. Stöckl B, Nogler M, Rosiek R, et al. Navigation improves accuracy of rotational alignment in total knee arthroplasty. *Clin Orthop Relat Res* 2004;426:180-6.
25. Heesterbeek PJ, Jacobs WC, Wymenga AB. Effects of the balanced gap technique on femoral component rotation in TKA. *Clin Orthop Relat Res* 2009;467:1015-22.
26. Heesterbeek PJ, Keijsers NL, Wymenga AB. Femoral component rotation after balanced gap total knee replacement is not a predictor for postoperative patella position. *Knee Surg Sports Traumatol Arthrosc* 2011;19:1131-6.
27. Whiteside LA, Kasselt MR, Haynes DW. Varus-valgus and rotational stability in rotationally unconstrained total knee arthroplasty. *Clin Orthop Relat Res* 1987;219:147-57.
28. Van Damme G, Defoort K, Ducoulombier Y, et al. What should the surgeon aim for when performing computer-assisted total knee arthroplasty? *J Bone Joint Surg [Am]* 2005;87-A:52-8.

## 4.2 THE ORIENTATION OF THE TIBIO-FEMORAL JOINT LINE IN THE CORONAL PLANE

### 4.2.1 THE EFFECT OF JOINT LINE ORIENTATION ON ALIGNMENT AFTER TKA.

**T Luyckx, F Vanhorebeeck, J Bellemans**

Should we aim at undercorrection when doing a Total Knee Arthroplasty?

*Knee Surg Sports Traumatol Arthrosc* 2014; epub ahead of print

doi 10.1007/s00167-014-3185-0

#### ABSTRACT

##### **Purpose:**

Restoration of neutral mechanical alignment is traditionally considered as one of the prerequisites for successful total knee replacement. The purpose of this study was to investigate whether a certain bias towards undercorrection exists with conventional TKA instruments.

##### **Methods**

A cohort of 456 consecutive patients, who underwent the same standardized TKA with restoration of neutral mechanical alignment as target, was studied. Based on the preoperative alignment, patients were stratified into three categories: valgus, neutral and varus. Component and limb alignment were compared between these groups.

##### **Results**

The mean postoperative HKA angle was  $-0.7^\circ$  (SD 2.5) in valgus knees,  $0.2^\circ$  (SD 1.9) in neutral knees and  $2.4^\circ$  (SD 3.9) in varus knees ( $p < 0.001$ ). 39.8% of the varus knees remained in  $>3^\circ$  of varus postoperative, 20.2% of the valgus knees remained in  $< -3^\circ$  of valgus. A systematic unintentional under-correction was noted in varus knees, which was proportional to the preoperative varus deformity and which was caused by varus positioning of both the femoral and tibial component. In valgus knees the under-correction was caused almost exclusively by valgus bias of the femoral component's position.

##### **Conclusion**

This study showed that conventional TKA instruments are associated with a systematic unintentional bias towards undercorrection of the pre-existing deformity. The clinical relevance of this study is that intentionally aiming at slight undercorrection of the deformity may lead to excessive undercorrection

in reality in case the surgeon does not recognise the automatic bias that already exists with standard instruments.

## INTRODUCTION

The concept of the constitutional varus was recently introduced by Bellemans et al, showing that a significant proportion of the healthy population has a natural alignment  $\geq 3^\circ$  of varus at the end of growth [1]. Correcting the coronal limb alignment during total knee arthroplasty (TKA) to a neutral mechanical axis might indeed create an abnormal situation in these patients. Only correcting for the worn cartilage and bone and not for the pre-existing varus deformity would therefore mean that one would have to accept postoperative varus. Growing evidence exists that slight undercorrection might not be as harmful for the survival of the implant as previously thought [2, 6, 8, 10, 11], and might actually result in a better clinical outcome [13]. However, aiming at slight undercorrection also inherently carries the risk of ending up in severe undercorrection, which could be detrimental for implant survivorship.

Based upon these arguments, surgeons recently have started to consider slight undercorrection of the deformity, while at the same time avoiding important severe undercorrection. Such requires of course a great degree of accuracy during surgery, as well as a correct understanding of what is obtained today when using contemporary TKA systems. It has indeed for a long time been our impression that with current TKA techniques and instruments, a certain error bias towards undercorrection already exists. Recent literature has demonstrated that with contemporary TKA systems neutral mechanical alignment is only obtained in 70- 80% of the patients, even when performed by experienced surgeons [2, 8, 10, 11, 13].

The purpose of this study was to investigate this in a large patient cohort. Our hypothesis was that current TKA instruments are already associated with an automatic bias towards undercorrection of the deformity (1), and that such bias is proportional to the magnitude of the arthritic deformity (2).

## MATERIALS AND METHODS

456 consecutive patients who underwent a posterior stabilised (PS) TKA at our service between 2009 and 2011 were studied. All patients (1045) undergoing a TKA during that period were prospectively included in our knee arthroplasty database. Selection criteria were applied to these 1045 patients. Only the patients with primary osteoarthritis as indication were selected (997). Patients with

rheumatoid arthritis or posttraumatic osteoarthritis were excluded (48). To avoid bias from different instrumentation systems, only the patients receiving the Genesis II PS prosthesis (Smith & Nephew Inc., Andover, Massachusetts) were included (509). Other types of prostheses were excluded. 22 cases were excluded because radiographs were not taken according to Paley's criteria[9]. Fourteen patients with bilateral TKA surgery (2x14) were also excluded. As a result of all these selection criteria, our working database consisted of 456 patients.

All surgeries were performed in a single institution (Department of Orthopaedic Surgery, University Hospital Leuven, Pellenberg, Belgium) by one surgical team. An intra-medullary instrumentation technique was used on both the femur and tibia with the restoration of a neutral mechanical alignment as target in all knees. To obtain a tibial cut perpendicular to the mechanical axis, the extra-medullary alignment system was used in conjunction with the intramedullary alignment. First, the tibial cutting block was fixed using the intramedullary system, introduced through a central drill hole in the proximal tibia. Next, the extra-medullary alignment system was attached to the cutting block as a check and adjustment were made when necessary. In cases of excessive tibial bowing, only the extra-medullary system was used. For the femur, a standard 5° valgus angle was used in all patients except in women with an 8° or more valgus angle as measured on the pre-operative full limb standing radiographs. A 6° valgus angle was used in these patients. In all cases the intramedullary rod was inserted through a centrally located drill hole just anterior to the top of the notch and slightly medial.

Standard standing antero-posterior (AP), lateral and full-leg radiographs were obtained of all knees pre- and post-operatively as part of a standard TKA protocol. The weight-bearing full-leg radiographs, which included the whole pelvis, were obtained with the patient standing while ensuring that the patellae were oriented forwards, as we described previously [1]. These radiographs were calibrated and all measurements were performed using the AGFA Picture Archive and Communication System (PACS) (Agfa- Gevaert, Mortsel, Belgium). Alignment of the leg was determined based these radiographs. Femoral and tibial mechanical axes were defined according to the criteria defined by Cooke et al. [5]. The hip centre was obtained using concentric Moose circles. The pre-operative centre of the knee was determined as the intersection of the midline between the tibial spines and the midline between the femoral condyles and tip of the tibia. The centre of the ankle was determined as the mid-width of the talus. Post- operatively, full-length hip–knee–ankle radiographs were repeated, and the centre of the hip and ankle was calculated as mentioned above. After TKA, the centre of the knee was determined as the intersection of the midline in the middle of the polyethylene inlay and the midline between the condyles of the femoral component and the tip of the tibial component. Using these three points on the pre- and post- operative radiographs, the hip-



knee-ankle (HKA) angle of the lower leg could be calculated. The HKA angle was defined as the angle formed by the mechanical femoral axis and the mechanical tibial axis. The HKA angle was expressed as a deviation from 180° with a negative value for valgus and positive value for varus alignment. The lateral angle formed between the mechanical femoral axis and the knee joint line of the distal femur was defined as the mechanical lateral distal femoral angle (mLDFA). The medial proximal tibial angle (MPTA) was defined as the medial angle formed between the mechanical tibial axis and the knee joint line of the proximal tibia. The angle between the knee joint lines of the distal femur and proximal tibia was called the joint line convergence angle (JLCA). An independent observer (FV) performed the radiographic measurements within a range of accuracy of 0.1°. Literature has shown a high intra- and inter-observer accuracy using this method [4, 12].

The patients were subdivided into three categories, based on their pre-operative HKA angle: HKA angle  $> 3^\circ$  = varus;  $- 3^\circ \leq$  HKA angle  $\leq 3^\circ$  = neutral; HKA angle  $< - 3^\circ$  = valgus.

The study protocol was approved by the Ethics Committee of the University of Leuven, Belgium.

According to the pre-operative alignment, there were 249 varus knees (54.6%), 103 neutral knees (22.6%) and 104 valgus knees (22.8%). Demographic variables for these groups are presented in table 1.

#### Statistical analysis

Signed rank tests are used to evaluate differences between pre- and post-operation measurements. Groups are compared with  $\chi^2$ -test (or Fisher's exact tests) and Mann-Whitney U tests (Kruskal-Wallis for the comparison of more than two groups). Associations between variables are verified with Spearman correlations. A (bivariable) linear regression model is used to relate the post-operative HKA with the postoperative tibial and femoral joint line orientation. P-values smaller than 0.01 are considered significant. All analyses have been performed using SAS software, version 9.2 of the SAS System for Windows (SAS Institute Inc., Cary, NC, USA).

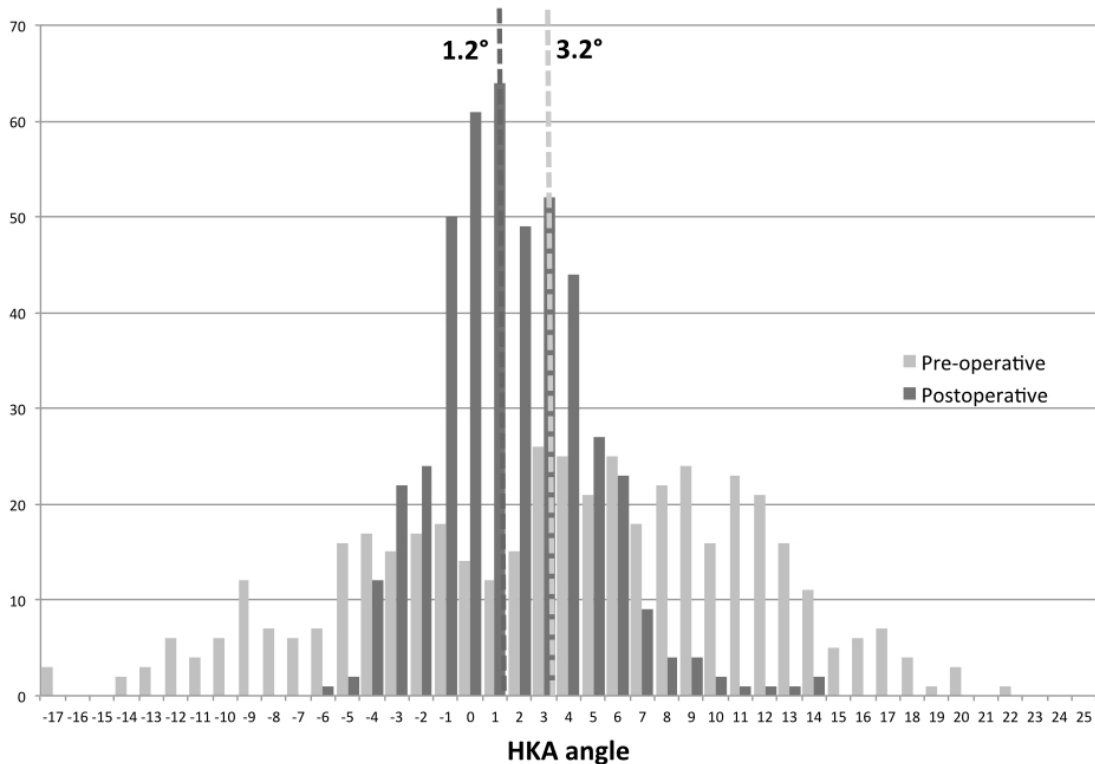
**Table 1:** Demographic variables. Absolute values are presented with standard deviation. (\*) indicates a statistical significant difference between valgus and varus knees ( $p < 0.01$ )

Variable	Valgus (n=104)	Neutral (n=103)	Varus (n=249)
<b>Age (years)</b>	68.0 ± 12.0	65.2 ± 12.4	67.6 ± 10.6
<b>Gender</b>			
Female	76.0%*	66.0%	52.2%*
Male	24.0%*	34.0%	47.8%*
<b>BMI</b>	27.8 ± 4.9	27.5 ± 5.9	30.3 ± 4.2

## RESULTS

The mean HKA angle was found to be 3.2° (SD 7.7) in the osteo-arthritic knee and was 1.2° (SD 3.1) after TKA ( $p < 0.001$ ) (fig 1). The mean HKA angle after TKA was -0.7° (SD 2.5) in knees that were pre-operatively in valgus, 0.2° (SD 1.9) in knees that were pre-operatively neutral and 2.4° (SD 3.9) in knees that were pre-operatively in varus. This was a statistically significant difference (table 2).

Out of the 249 patients with pre-operative varus, 39.8% remained in  $>3^\circ$  of varus after TKA. Out of the 104 patients with pre-operative valgus, 20.2% remained in  $< -3^\circ$  of valgus (table 3). 85.4% of the pre-operative neutrally aligned knees remained neutral postoperative. 14.6% of the neutral knees were overcorrected to either a varus or valgus alignment postoperative.



**Figure 1:** Histogram depicts the distribution of the HKA angle before (red) and after (blue) TKA in all 456 patients. The mean HKA angle for each population is indicated with the dotted line

A systematic unintentional under-correction was seen in varus knees ( $R^2=0.58597$ ) (fig 2). The more pre-op varus, the more under-correction was performed. The same under-correction existed for valgus knees, although significantly less pronounced ( $R^2=0.60561$ ) ( $p < 0.001$ ). The median correction of the alignment deformity was 89.3% in valgus knees versus 75.7% in varus knees ( $p=0.002$ ).

Variable	Preoperative alignment			Pairwise comparisons			
	Valgus (1)	Neutral (2)	Varus (3)	P value	1 versus 2	1 versus 3	2 versus 3
HKA pre	-7.6 (3.7)	0.2 (1.9)	9.0 (3.9)	<.001	<.001	<.001	<.001
HKA post	-0.7 (2.5)	0.1 (2.1)	2.4 (3.1)	<.001	0.006	<.001	<.001
Correction (°)	7.0 (4.3)	2.2 (1.7)	6.8 (3.8)	<.001	<.001	n.s.	<.001
mLDFA pre	85.5 (2.8)	87.6 (2.1)	89.5 (2.5)	<.001	<.001	<.001	<.001
mLDFA post	89.1 (1.9)	89.9 (1.6)	91.1 (2.2)	<.001	=.0001	<.001	n.s.
Correction (°)	3.6 (3.2)	2.3 (2.6)	1.6 (2.9)	<.001	<.001	<.001	<.001
MPTA pre	90.9 (2.6)	88.5 (2.6)	85.0 (3.4)	<.001	<.001	<.001	<.001
MPTA post	89.8 (2.2)	89.8 (1.7)	88.8 (2.1)	n.s.	<.001	<.001	<.001
Correction (°)	-1.1 (3.1)	1.3 (3.0)	3.8 (3.7)	<.001	<.001	<.001	<.001
JLCA	4.8 (2.3)	2.3 (1.7)	2.4 (1.9)	<.001	<.001	<.001	n.s.

**Table 2:** The different alignment and joint line measurements according to the pre-operative alignment. Data are represented as means with standard deviation. The correction is the difference between the pre- and postoperative situation.

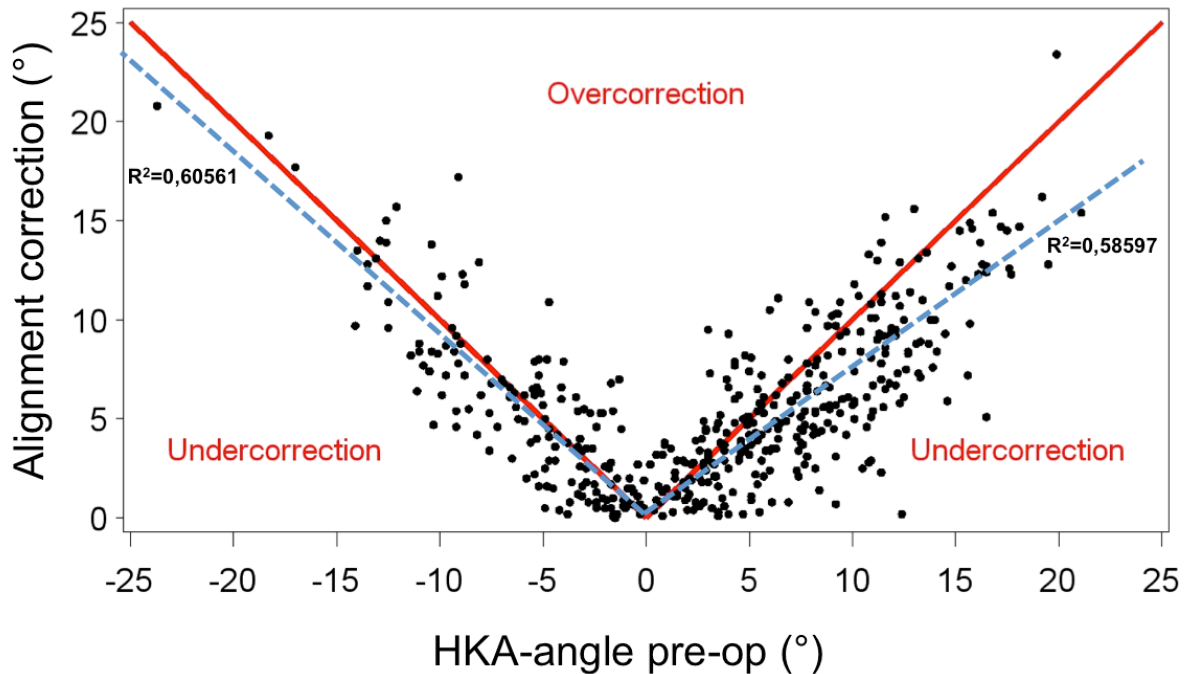
Variable	Pre-operative alignment				Pairwise comparisons			
	All	Valgus (1)	Neutral (2)	Varus (3)	P-value	1 vs 2	1 vs 3	2 vs 3
<b>HKA post</b>								
Valgus (<-3°)	7.7%	20.2%	3.9%	4.0%	<0.001	0.001	<.001	n.s.
Neutral	66.4%	72.1%	85.4%	56.2%	<0.001	<0.01	<.001	<.001
Varus (>3°)	25.9%	7.7%	10.7%	39.8%	<0.001	0.01	<.001	<.001

**Table 3:** The alignment after TKA in the different pre-operative alignment categories. All but one show a statistical significant difference between the different alignment categories.

The undercorrection in varus knees was the consequence of varus of both the femoral and tibial component (fig 3). The femoral component contributed to 45.8% of the postoperative varus, the tibial component to 50%. In valgus knees the under-correction was caused almost exclusively by valgus bias of the femoral component's position.

The joint line anatomy (MPTA, mLDFA) of the osteo-arthritic knee proved to be significantly different in the different alignment groups (table 2). In valgus knees, the main coronal plane deformity is located on the femoral side with an average 4.5° deviation of the mLDFA from neutral (fig 4). The deviation on the tibial side in valgus knees is minimal in most cases (mean 0.9°). In varus knees on the other hand, the femur is almost neutrally aligned with an mLDFA of on average 89.5°. The deformity is found on the tibial side here with a deviation from neutral of the MPTA of on average 5.0°. The neutral knee shows a combination of slight femoral valgus with slight tibial varus.

After TKA, the mLDFA and MPTA were similar in neutral and valgus knees but significantly different when compared to varus knees (table 2).

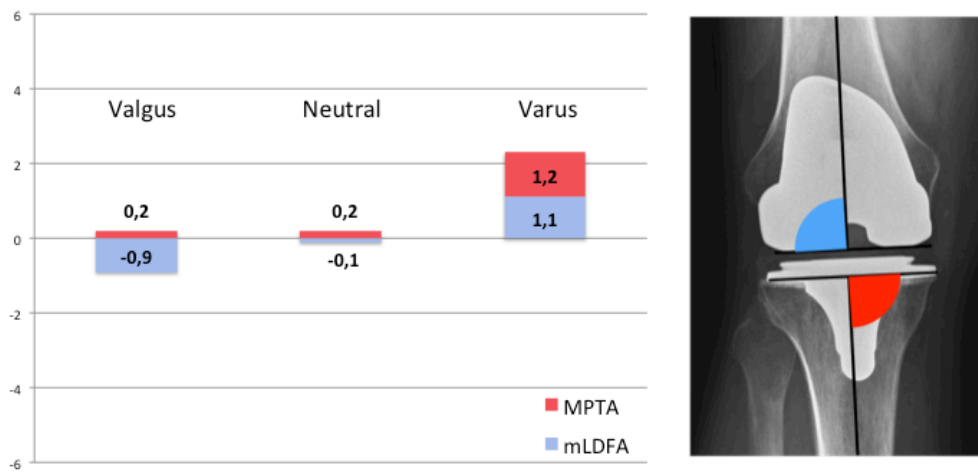


**Figure 2:** A scatter plot of the preoperative mTFA against the alignment correction that was performed. The red lines represents the required correction for a 0° mTFA. The blue line represents the linear correlation for the actual achieved correction. All values above the red lines represent overcorrection, everything below the line represents undercorrection. E.g. a knee with a preoperative mTFA of 5° requires a 5° correction to achieve a neutral alignment but on average, a 4° correction was done. A systematic under-correction is seen in varus knees. The more the varus, the more undercorrection. The same observation exists in valgus knees, although significantly less pronounced.

## DISCUSSION

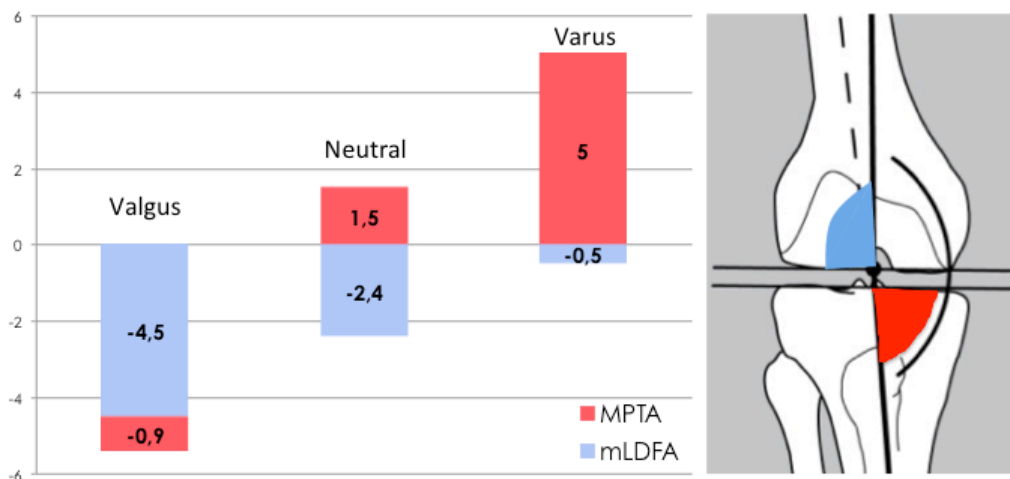
The most important finding of this study was that in conventional TKA, there is an inherent unintentional bias towards undercorrection of the pre-existing deformity. Such bias is proportional with the magnitude of the preoperative deformity. In other words, the more preoperative varus (or valgus) the more undercorrection is performed. The bias towards undercorrection is also greater in varus knees than in valgus knees. The median correction of the alignment deformity was 89.3% in valgus knees versus 75.7% in varus knees ( $p=0,002$ ). It is important to note that the target in all of these cases was to restore the knee to neutral mechanical alignment. The tendency towards undercorrection was therefore unintentional.

### After TKA



**Figure 3:** The different joint line angles after TKA and their contribution to the overall limb alignment (HKA-angle), stratified according to the pre-operative alignment. The medial proximal tibial angle (MPTA) and the mechanical lateral distal femoral angle (mL DFA) are expressed as deviation from neutral. The average value for each alignment category is shown.

### Native knee



**Figure 4:** The different joint line angles in the native osteo-arthritic knee and their contribution to the overall limb alignment (HKA-angle), stratified according to the pre-operative alignment. The medial proximal tibial angle (MPTA) and the mechanical lateral distal femoral angle (mL DFA) are expressed as deviation from neutral. The average value for each alignment category is shown.

These observations shed a new light over the alignment discussion in TKA. Should we aim at under-correction in patients with pre-operative varus in order to restore the patient's anatomy rather than reproduce a neutral mechanical alignment? Before we can answer that question, we should first understand what alignment is actually achieved with classic instrumented TKA and identify the

factors influencing this. Such knowledge is crucial before a shift in alignment target can be advocated. Based on our data, aiming at slight varus instead of neutral when performing a TKA is very likely to cause more varus outliers. In our series, already 8.8% of the patients had an HKA-angle of more than 6° of varus after TKA. And according to our previously published data, those patients might perform worse [13]. We would therefore caution against a global shift of the alignment target towards slight varus.

There are several mechanisms that can explain these findings. The use of an intramedullary instrumentation system on the femur and a combined system on the tibia is influenced by the patient's anatomy. Femoral bowing and the position of the entry hole will influence the course of the intra-medullary rod in the femur and thus the valgus resection angle. From our previous work, we know that the valgus angle is on average 4.51° in varus knees, 4.44° in neutral knees and 3.98° in valgus knees [1]. One would therefore expect that a standard 5° valgus cut would cause some undercorrection on the femoral side. This is indeed true for valgus knees. However, a slight varus position of the femoral component is observed in most varus knees in our series. Varus femoral bowing observed in varus knees might be an explanation for this [1]. This varus femoral bowing was found to be 0.45° in varus knees [1]. In neutral knees and valgus knees a femoral bowing of 0.11° and 0.16° respectively was observed. Proximal tibial varus is another important variable. With an intramedullary technique and a central entry hole on the tibia, this proximal tibial varus will cause a bias toward varus of the tibial cut. We were well aware of this bias while performing the surgery. To avoid it, we use a combined intra- and extra-medullary technique on the tibia. Nevertheless, a bias toward varus of the tibial component in varus knees was still observed. This effect was absent in valgus and neutral knees. Also the surgeon should be considered an important variable in the alignment equation. In this study, all surgeries were performed by the same surgical team. This team consisted of two leading senior surgeons and senior orthopaedic residents under their supervision. As multiple surgeons were involved, we believe that these results are relative surgeon independent and can therefore be attributed to the instrumentation technique and the patient's anatomy mainly.

In the debate on limb alignment after TKA, the focus has mainly been on varus knees as they make out the biggest proportion of the osteoarthritic knees that are treated with a TKA (54.6% of the knees in our series). However, neutral knees and valgus knees should not be overlooked. In this study, we found a distinct joint line anatomy between the 3 alignment categories (fig 4). In valgus knees, the main coronal plane deformity is mainly located on the femoral side with an average -4.5° deviation of the mLDFA from neutral. The deformity on the tibial side in valgus knees is minimal in most cases (mean 0.9°). In varus knees on the other hand, the femur is almost perfectly neutrally

aligned with an mLDFA of on average 89.5°. The deformity is found on the tibial side here with on average 5.0° proximal tibial varus. The same instrumentation technique resulted in a different postoperative joint line configuration in the 3 groups (fig 3). Conclusions on varus knees can therefore not automatically be implemented on neutral and valgus knees. Femoral component valgus for instance, might indeed be harmful for a knee that was pre-operatively in varus [8] but might on the other hand give a better results in a valgus knee. Failure to stratify results according to the pre-operative alignment is therefore one of the major limitations of previous outcome studies on alignment after TKA [11].

This study has several limitations. First of all, patients with a flexion contracture were not excluded from the analysis. We are well aware of the fact that a flexion contracture decreases the accuracy of measuring coronal limb alignment [3, 7]. However, a flexion contracture is inherently bound to the osteoarthritic process and is frequently seen in more severe osteoarthritis. Exclusion of these patients would therefore also introduce selection bias. Secondly, only results of one instrumentation system were analysed. Other systems could produce different results. Thirdly, a standard 5° valgus resection angle was selected in most cases. Using a different angle might result in different data.

## CONCLUSION

This study showed that conventional TKA instruments are inherently associated with a systematic unintentional bias towards undercorrection of the pre-existing deformity. Such bias was proportional with the magnitude of the preoperative deformity, and was greater in varus knees than in valgus knees. Based on these results we caution against a shift of the alignment target toward more varus, as this is likely to cause more varus outliers. The clinical relevance of this study is that intentionally aiming at undercorrection of the deformity during TKA may lead to excessive undercorrection in reality in case the surgeon does not recognise this automatic bias.

## REFERENCES

1. Bellemans J, Colyn W, Vandenuecker H, Victor J (2012) The Chitranjan Ranawat award: is neutral mechanical alignment normal for all patients? The concept of constitutional varus. *Clin. Orthop. Relat. Res.* 470:45–53
2. Bonner TJ, Eardley WGP, Patterson P, Gregg PJ (2011) The effect of post-operative mechanical axis alignment on the survival of primary total knee replacements after a follow-up of 15 years. *J. Bone Joint Surg. Br.* 93:1217–22
3. Brouwer RW, Jakma TSC, Brouwer KH, Verhaar JAN (2007) Pitfalls in determining knee alignment: a radiographic cadaver study. *J. Knee Surg.* 20:210–5
4. Colebatcha AN, Hartb DJ, Zhaib G, Williamsb FM, Spectorb TD, Ardena NK (2009) Effective measurement of knee alignment using AP knee radiographs. *Knee* 16:42–45
5. Cooke TD V, Sled EA, Scudamore RA (2007) Frontal plane knee alignment: a call for standardized measurement. *J. Rheumatol.* 34:1796–801
6. Fang DM, Ritter MA, Davis KE (2009) Coronal alignment in total knee arthroplasty: just how important is it? *J. Arthroplasty Elsevier B.V.* 24:39–43
7. Lonner JH, Laird MT, Stuchin SA (1996) Effect of rotation and knee flexion on radiographic alignment in total knee arthroplasties. *Clin. Orthop. Relat. Res.* 102–6
8. Magnussen RA, Weppe F, Demey G, Servien E, Lustig S (2011) Residual varus alignment does not compromise results of TKAs in patients with preoperative varus. *Clin. Orthop. Relat. Res.* 469:3443–50
9. Paley D (2002) *Principles of Deformity Correction*. Springer Berlin Heidelberg, Berlin, Heidelberg, pp 1–60
10. Parratte S, Pagnano MW, Trousdale RT, Berry DJ (2010) Effect of postoperative mechanical axis alignment on the fifteen-year survival of modern, cemented total knee replacements. *J. Bone Joint Surg. Am.* 92:2143–9
11. Ritter MA, Davis KE, Meding JB, Pierson JL, Berend ME, Malinzak RA (2011) The effect of alignment and BMI on failure of total knee replacement. *J. Bone Joint Surg. Am.* 93:1588–96
12. Sabharwal S, Zhao C EM (2008) Lower Limb Alignment in Children: Reference Values Based on a Full-Length Standing Radiograph. *J Pediatr Orthop* 28:740–746
13. Vanlommel L, Vanlommel J, Claes S, Bellemans J (2013) Slight undercorrection following total knee arthroplasty results in superior clinical outcomes in varus knees. *Knee Surg. Sports Traumatol. Arthrosc.* 21:2325–30



## 4.2.2 THE EFFECT OF JOINT LINE ORIENTATION ON CLINICAL OUTCOME AFTER TKA.

**T. Luyckx, F. Matassi, L. Vanlommel, S Claes, J. Bellemans**

Influence of component alignment on clinical outcome after total knee arthroplasty in varus knees

*Manuscript prepared for submission to the KSSTA journal*

### ABSTRACT

#### **Background.**

In the light of the concept of the constitutional varus, it was recently shown that slight undercorrection after TKA in varus knees might result in a better functional outcome. The question how to obtain this undercorrection in terms of alignment of the femoral and tibial component and thus joint line orientation remains however unanswered.

#### **Purposes.**

The purpose of this study was therefore to determine the effect of femoral and tibial component orientation in the coronal plane on clinical and functional scores following total knee arthroplasty in a cohort of patients with preoperative varus deformity.

#### **Methods.**

A cohort of 132 consecutive patients (143 knees) with pre-operative varus alignment was evaluated with a mean follow-up period of 7.2 years. Based upon the component orientation, patients were stratified into three groups for femoral alignment (varus, neutral and valgus) and two groups for tibial alignment (neutral and varus). These groups were compared with respect to clinical and functional outcomes

#### **Results.**

One revision for persistent pain occurred at midterm follow-up.

Knees with a postoperative hip-knee-ankle angle (HKA-angle) in mild varus (3-6°) scored significantly better for the KSS and the WOMAC, compared with knees that were corrected to neutral and knees that were left in severe varus exceeding 6°.

After TKA, the mean MPTA was found to be 0.9° (SD 1.2) in the neutral group, 1.9° (SD 1.1) in the mild varus group and 2.7° (SD 1.7) in the severe varus group (fig 2). The mean LDFA was -0.5° (SD 1.5) in the neutral knees, 1.8° (SD 1.7) in the mild varus knees and 3.4° (SD 1.8) in the severe varus knees.

These were all significant differences ( $p < 0.01$ ).

A significant better knee sub-score was found for the neutrally aligned tibial component compared to the varus aligned tibial component and for the neutrally aligned femoral component compared to a varus femoral component.

The best clinical results were obtained with a tibial component in slight varus ( $< 2^\circ$ ) combined with a HKA-angle in mild varus ( $3-6^\circ$ ). The worst results were obtained with a neutrally aligned tibia in a neutrally aligned limb and with a varus aligned tibia in a varus-aligned limb ( $> 6^\circ$ ).

### **Conclusions.**

In patients with varus osteo-arthritis of the knee, a slight undercorrection of the alignment resulted in a better clinical outcome after TKA. This undercorrection should be done carefully avoiding a combination of varus alignment of the femoral and tibial component greater than  $2^\circ$ .

## **INTRODUCTION.**

Restoration of neutral limb alignment with components positioned perpendicular to the mechanical axis is generally considered one of the prerequisites for successful outcome after total knee arthroplasty. Numerous authors recommend neutral alignment of both components in order to attain neutrality of the overall mechanical alignment. Deviation greater than  $3^\circ$  from this alignment, particularly in varus, has been associated with a decrease in implant survival [4, 9, 18, 19].

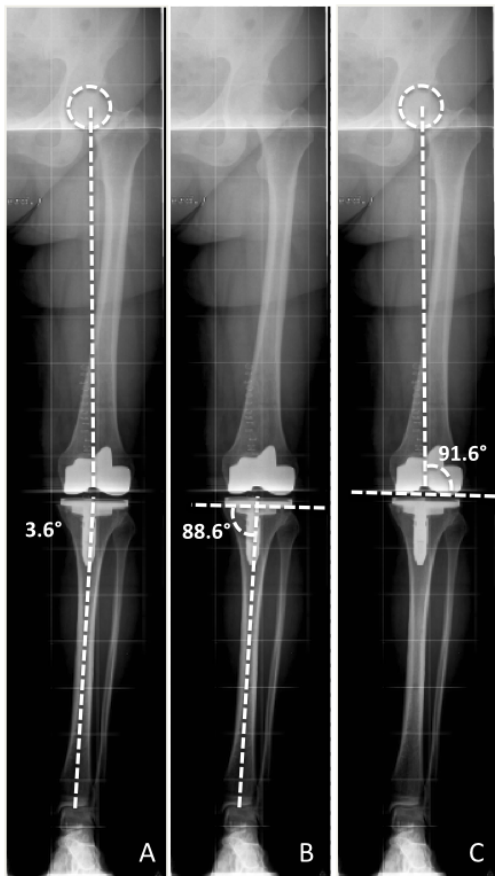
However, a significant proportion of the normal population has a natural limb alignment of more than  $3^\circ$  of varus[3]. In these patients, a total knee arthroplasty (TKA) with restoration of a neutral mechanical alignment might indeed be un-natural and non-physiological situation requiring significant releases of the collateral ligaments. Recent studies investigated the results after TKA in a selective series of patients with preoperative varus knee and demonstrated that slight undercorrection of the deformity is beneficial from a functional perspective[14, 22]. The authors concluded that residual varus limb alignment after TKA is associated with better clinical and functional outcome and showed the same survival rate compared to neutral aligned knee.

This residual varus HKA-angle can be obtained by both femoral or tibial component varus or by a combination of both[13]. The question how to obtain this undercorrection in terms of alignment of the femoral and tibial component and thus joint line orientation remains unanswered. The purpose of this study was therefore to determine the effect femoral and tibial component alignment and thus joint line orientation on clinical and functional scores following total knee arthroplasty in a cohort of patients with preoperative varus deformity.

The hypothesis was that slight undercorrection of the tibial and femoral component would be beneficial for the clinical outcome.

## MATERIALS AND METHODS.

We prospectively followed a consecutive series of 143 TKA's performed in 132 patients with Profix Posterior Stabilized total knee prosthesis (Smith & Nephew, Memphis, TN). The same cohort of patients was previously investigated to detect correlation between post-operative overall alignment and clinical scores [22]. The inclusion criteria for this study were medial arthritis of the knee and varus alignment defined by a hip-knee-ankle angle of more than 3° of varus. The indication for the surgery was primary osteoarthritis in all patients. Exclusion criteria were patients with valgus or neutral alignment of the leg, pre-operative radiographs or clinical scores that were not available, radiographs not taken according to Paley's criteria; patients with more than 5° of extension loss and patients lost to follow-up. The minimum follow-up was 5.2 years (mean, 7.2 years; range, 5.2–11.8 years).



**Figure 1.** A. Hip-Knee-Ankle (HKA) angle, B. Medial Proximal Tibial Angle (MPTA). C. Lateral Distal Femoral Angle (LDFA).

All the surgical procedures were performed in a single institution (Department of Orthopaedic Surgery, Leuven University Hospital—Pellenberg, Belgium), between 2002 and 2005 by one surgical team. All components were implanted using a measured resection technique, followed by appropriate soft tissue balancing. Exposure of the knee was obtained using a medial parapatellar incision. The valgus cut was performed using an intramedullary guide and an angle of 5° or 7° was chosen based on pre-operative measurement of the angle between the femoral anatomical axis and the femoral mechanical axis. Proper external rotation of the femoral component was assessed using a guide that referenced to the posterior condylar axis combined with bony landmarks [12]. The tibial resection was performed perpendicular to the mechanical axis of the tibia using a standard intramedullary alignment guide. The femoral, tibial, and patellar components were cemented using high-viscosity Palacos cement (Biomet, Warsaw, IN) for fixation. All patients followed the same post-operative rehabilitation protocol which consisted of 36h of epidural analgesia and daily physiotherapy until discharge. Discharge criteria were: at least 90° of knee flexion and a no wound leakage. The mean postoperative stay was 6 days.

Patients had clinical and radiographic evaluations preoperatively and postoperatively at 6 weeks, 3 months, 6 months and annually thereafter. The clinical evaluation was performed using the International Knee Society Score (KSS) and the Western Ontario and McMaster University Osteoarthritis Index (WOMAC). Radiographic evaluation consisted of AP view (weightbearing), a lateral view, and a patellar skyline view. Radiolucent lines were measured in millimetres in each designated zone for the femoral and tibial prostheses in the coronal and sagittal planes according to the method recommended by the Knee Society. Aseptic loosening was defined according to this radiographic scoring system of the Knee Society [8].

According to Paley's criteria, the weight-bearing full-leg radiographs were obtained pre- and post-operatively with the subjects standing barefoot with the patellae oriented forward [16]. The tibial alignment, femoral alignment, and overall anatomic alignment were measured to the nearest 0.1° by one of the authors (FM), using the AGFA PACS software package (Agfa-Gevaert). Femoral and tibial mechanical axes were defined according to the criteria defined by Cooke et al [6]. The tibial alignment was defined as the medial angle (MPTA) between the tangent to the tibial base plate and the tibial mechanical axis (fig 1). The femoral alignment was defined as the lateral angle (LDFA) between the distal portion of the femoral component and the mechanical axis of the femur (fig 1). The overall mechanical alignment (hip-knee-ankle angle = HKA-angle) was defined as the angle between the femoral mechanical axis (a line drawn through center of the hip to the center point of the knee on the femoral knee joint) and the tibial anatomic axis (a line drawn through center point of the knee on the tibial knee joint to the center of the ankle) (fig 1).

The KSS and WOMAC scores were compared based on alignment of the tibial component: varus alignment (MPTA < 88°) and neutral alignment (MPTA = 90° ± 2°). No cases of valgus tibial alignment (MPTA > 92°) were recorded. The same analysis was performed based on alignment of the femoral component relative to the mechanical axis of the femur: varus alignment (LDFA > 92°), neutral alignment (LDFA = 90° ± 2°) and valgus alignment (LDFA < 88°). Based upon postoperative overall limb alignment patients were divided into three groups: neutral group (HKA ± 3°), mild varus group (HKA >3° and < 6°) and severe varus group (HKA > 6°). Analysis of the individual component alignment was combined with the overall leg alignment and compared with respect to clinical and functional outcomes.

#### *Statistical Analysis*

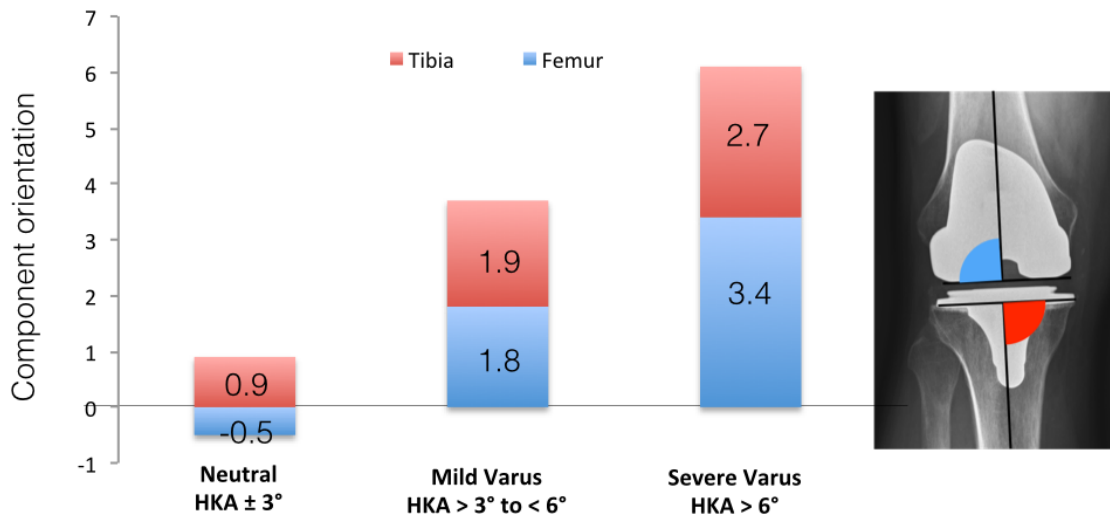
Spearman correlations were used to evaluate relations between continuous or ordinal variables. Kruskal-Wallis, Mann-Whitney U and Fisher's exact tests were used to compare variables between groups. To apply Tukey-Kramer adjustments of the p-values for the pairwise comparisons of the functional scores between groups defined on the postoperative tibia and femur alignment, a rank-based method not assuming equal variance as in the Kruskal-Wallis test have been used. P-values smaller than 0.05 were considered significant. All analyses were performed using SAS software, version 9.2 of the SAS System for Windows (SAS Institute Inc., Cary, NC, USA).

## RESULTS.

One of the knees had been revised at the latest follow-up. The diagnosis for revision was persistent pain. There were no arguments for loosening of the components on the pre-operative bone scan. The HKA-angle of the patient post TKA was 4.0° of valgus. The alignment of the tibial component was neutral (-0.4°).

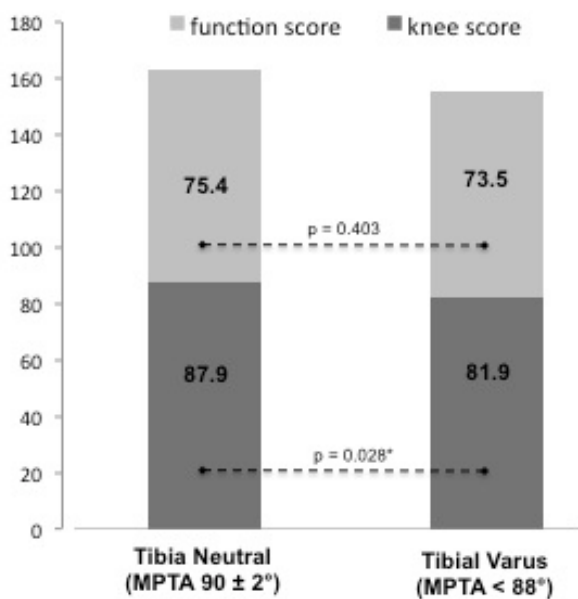
After TKA, the mean MPTA was found to be 0.9° (SD 1.2) in the neutral group, 1.9° (SD 1.1) in the mild varus group and 2.7° (SD 1.7) in the severe varus group (fig 2). The mean LDFA was -0.5° (SD 1.5) in the neutral knees, 1.8° (SD 1.7) in the mild varus knees and 3.4° (SD 1.8) in the severe varus knees. These were all significant differences (p<0.01).

The clinical result for the knees with a HKA-angle in mild varus was significantly better, as reported before [22].



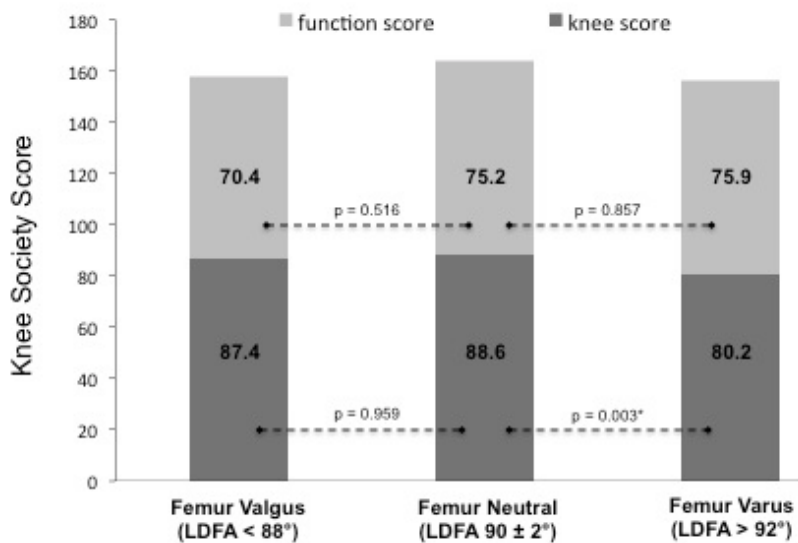
**Figure 2.** Post-operative joint line orientation of the tibial and the femoral component, expressed in degrees as deviation from neutral. A negative value means valgus alignment and a positive value means varus alignment.

The **orientation of the tibial component** (MPTA, Fig 1) was neutral 104 knees (72.7%) and in varus in 39 (27.3%). There was a tendency towards better mean KSS scores ( $163.5 \pm 24.31$  vs.  $155.4 \pm 26.07$ ;  $p = 0.067$ ) and mean WOMAC scores ( $22.3 \pm 19.72$  vs.  $26 \pm 20.56$ ;  $p = 0.45$ ) in the neutral group compared to the varus group. The difference did not reach statistical significance. The difference was however significant for the knee sub-score of the KSS score ( $87.9 \pm 13.51$  vs.  $81.9 \pm 14.94$ ;  $p = 0.028$ ) (fig 3).



**Figure 3.** Differences in postoperative KSS score between varus and neutral tibial component alignment.

The **orientation of the femoral component** (LDFA, Fig.1) was in varus in 37 knees (25.9%), neutral in 91 (63.6%) and valgus in 15 (10.5%). The mean WOMAC score and mean KSS scores were better in patients with neutral femoral component alignment ( $20.8 \pm 18.42$ ) ( $164.0 \pm 22.95$ ) compared to those with either valgus ( $28.6 \pm 20.0$ ;  $p = 0.19$ ) ( $157.7 \pm 24.05$ ;  $p = 0.44$ ) or varus positions ( $27.4 \pm 22.66$ ;  $p = 0.25$ ) ( $156.1 \pm 29.25$ ;  $p = 0.27$ ) although the difference was not statistically significant. The knee sub-score was higher in the neutral group compared to varus group ( $88.6 \pm 12.35$  vs  $80.2 \pm 16.08$ ;  $p = 0.003$ ). (Fig.4)



**Figure 4:** Differences in postoperative KSS score between the three groups according to femoral component alignment

Next, a **combined analysis** of the orientation of the individual component alignment and the overall leg alignment (HKA-angle) was performed. These results are shown in table 1. A neutrally aligned tibial component (<2° of varus) with an overall leg alignment in slight varus (3° < HKA-angle < 6°) yielded the best results. The worst results were obtained with a neutrally aligned tibia in a neutrally aligned limb and with a varus aligned tibia in a varus-aligned limb. No statistically significant conclusions could be made here for the femoral component.

Variable	Statistic	Tibia neutral, Femur Valgus	Tibia neutral, Femur Neutral	Tibia neutral, Femur Varus	Tibia varus, Femur Neutral	Tibia varus, Femur Varus	Tibia varus, Femur Valgus
N		13	67	24	24	13	2
KSS total	Mean	154.0 ± 23.58	164.6 ± 23.15	165.4 ± 27.36	162.6 ± 22.85	137.5 ± 24.29	180 ± 15.56
HKA post	Mean	-1.3 ± 1.5	1.5 ± 1.81	5.3 ± 0.28	4.2 ± 1.77	7.2 ± 2.31	2.4 ± 0.28

**Table 1:** KSS score between the groups according to tibial alignment and overall limb alignment.

## DISCUSSION.

The most important finding of this study was that when we performed a TKA in a varus knee, the best clinical results were obtained with a tibial component in slight varus ( $<2^\circ$ ) combined with a HKA-angle in mild varus ( $3-6^\circ$ ). The worst results were obtained with a neutrally aligned tibia in a neutrally aligned limb and with a varus aligned tibia ( $>2^\circ$ ) in a varus-aligned limb ( $>6^\circ$ ). Therefore undercorrection in preoperative varus knee should be done carefully avoiding a combination of varus alignment of the femoral and tibial component of greater than  $2^\circ$ .

Limb alignment and component position in total knee replacement are important variables controlled by the surgeon that affect post-operative functional result and survival of the implant. Attaining neutrality in tibial component alignment, femoral component alignment and overall limb alignment is widely considered as one of the prerequisites for successful outcome in TKA [1, 2, 11, 18, 21]. However most of the studies in literature featured multiple types of knee designs. Moreover, revision rates or IKS scores were not stratified based on preoperative alignment. This is important, because the ideal postoperative alignment could in part be determined by the extent and type of the preoperative deformity and this is not the same for every patient. Restoring the alignment to the normal pre-arthritis situation and not to the neutral could be perceived as more natural to the patient and could lead to superior functional scores after TKA. Recent investigations with the use of modern implant designs did not show any significant differences in revision rates between neutral or varus aligned TKA's in a cohort of patient with preoperative varus alignment [5, 14, 15, 17]. Vanlommel et al. suggested that undercorrection of the preoperative deformity in a cohort of preoperative varus knee is associated with better functional outcomes when compared to restoration of the neutral mechanical axis [22]. They found better subjective and functional outcome scores for knees that were left in mild varus (HKA angle between  $3^\circ$  and  $6^\circ$ ) compared with knees corrected to neutral ( $0^\circ \pm 3^\circ$ ) and knees left in severe varus exceeding  $6^\circ$ . However in this study correlation between component alignment and clinical score were not investigated.

The present study is a second step in the analysis of this previously reported series with the purpose to investigate correlation between component alignment and clinical and functional results in the same cohort of patients with preoperative varus alignment. The best results were obtained for a neutrally aligned tibial component with an overall leg alignment in mild varus. To obtain this mild varus HKA-angle, a minimal varus orientation of the tibial component ( $< 2^\circ$ ) was combined with a minimal varus orientation of the femoral component ( $<2^\circ$ ). In this mild varus group (HKA angle between  $3^\circ$  and  $6^\circ$ ), the orientation of the femoral component was on average in  $1.8^\circ$  of varus and the orientation of the tibial component was on average  $1.9^\circ$  of varus (fig 2). Together, these resulted



in a mild varus HKA-angle.

These results show that component alignment and HKA-angle are intimately bound to each other and have an important influence on each other. A varus aligned tibial component was well tolerated in a mild varus limb but yielded worse results in a severe varus limb. A neutrally aligned tibial component in a mild varus limb gave the best results but the neutral tibial component in the neutral limb led to worse results. A second important remark is that all patients had pre-operative varus. The component orientation that is ideal for a pre-operative varus knee might not be ideal in a neutral or valgus knee. Care should therefore be taken not to generalize these conclusions to all knees.

The effect of mechanical alignment in the coronal plane on survival is well documented in literature. The influence of individual component alignment is less clear. Reports suggested that tibial varus alignment is associated with high failure rate and low clinical score after TKA recommending neutral position of this component [18]. Moreover, retrieval analysis of the insert showed increase volumetric penetration rate when the tibial component is placed in more than 3° varus [20]. However these studies do not consider component alignment according to the preoperative situation. Howell et al. showed that, when the articular surfaces of the femur and tibia are restored to their normal or pre-arthritis level and not to the neutral, the need for ligament releases is significantly reduced and the functional results are better [7, 10]. Ritter et al. reported the same survival rate for TKA with tibia in neutral position and overall alignment neutral compared to the group with tibia in neutral position and overall alignment in varus [18]. Similarly to our findings, Magnussen et al. reported that residual postoperative varus deformity after TKA is not associated with lower postoperative IKS scores or increased failure rates [14]. However, when the residual varus is caused by tibial component varus of more than 3°, the revision rate is higher and IKS score lower compared to the group with residual varus and tibia in neutral position [14].

Data on the alignment of the femoral component are more sparse. Survival rates were reported to be better when the position is neutral compared to valgus [18]. Again, no stratification based on the pre-operative limb alignment was performed in this study. Some surgeons would advocate varus alignment of the femoral component together with a neutral tibia in varus knees. Our findings show care should be taken not to exceed 2° of varus of the femoral component as this is also associated with a worse clinical outcome. Varus alignment of the femoral component in a varus knee might therefore not be as well tolerated as previously thought.

This study has several limitations. First, all components in this study were from one manufacturer and one type of prosthesis. This excluded possible confounders from different types of prostheses but additional studies are required to confirm or deny our results using other types of prostheses

from other manufacturers. Second, the relatively short median follow-up leaves the study underpowered to detect differences in failure rate based on component alignment. However, analysis of the survival rate according to the component position was not the primary purposes of this study. Third, in the knee sub-score of the KSS, more points are awarded to knees with neutral alignment, which lowered the knee sub-score in the group with varus overall alignment and varus component alignment. This is an important limitation that may explain the lower knee score obtained for varus placement of tibial or femoral components. However the results of the functional score and WOMAC score showed the same tendency. Fourth, we were not able to analyse all the possible combinations between femoral and tibial component alignment because of an insufficient number of patients in some subgroups. For example, we were unable to compare KSS scores in patients with varus tibial component combined with valgus femoral component with the other groups. For the same reason we were unable to analyse the effect of tibial valgus alignment on clinical and functional results. However, the fact that those combinations of component alignment are rare in varus knees means that their clinical importance is limited.

One revision was performed during the follow-up period in the current analysis. This revision was not due to aseptic loosening or wear. Some recent studies observed an association between tibial component varus alignment and increase failure rates. The mean follow-up of our patients is midterm in length, and therefore, it is too early to draw conclusions on whether there is a correlation between component alignment and revision rates. Further follow-up will be required to effectively address this question.

## CONCLUSION.

In a cohort of patients with pre-operative varus osteo-arthritis, a slight undercorrection resulted in better clinical outcome after TKA. This undercorrection should be done carefully avoiding a combination of varus alignment of the femoral and tibial component of greater than 2°. The best clinical results were obtained with a tibial component in slight varus (<2°) combined with a HKA-angle in mild varus (3-6°).

## REFERENCES

1. Aglietti P, Buzzi R (1988) Posteriorly stabilised total-condylar knee replacement. Three to eight years' follow-up of 85 knees. *J. Bone Joint Surg. Br.* 70:211–6
2. Bargren JH, Blaha JD, Freeman MA (1983) Alignment in total knee arthroplasty. Correlated biomechanical and clinical observations. *Clin. Orthop. Relat. Res.* 178–83
3. Bellemans J, Colyn W, Vandenuecker H, Victor J (2012) The Chitranjan Ranawat award: is neutral mechanical alignment normal for all patients? The concept of constitutional varus. *Clin. Orthop. Relat. Res.* 470:45–53
4. Berend ME, Ritter MA, Meding JB, Faris PM, Keating EM, Redelman R, Faris GW, Davis KE (2004) The Chetranjan Ranawat Award: Tibial Component Failure Mechanisms in Total Knee Arthroplasty. *Clin. Orthop. Relat. Res.* 428:26–34
5. Bonner TJ, Eardley WGP, Patterson P, Gregg PJ (2011) The effect of post-operative mechanical axis alignment on the survival of primary total knee replacements after a follow-up of 15 years. *J. Bone Joint Surg. Br.* 93:1217–22
6. Cooke TD V, Sled EA, Scudamore RA (2007) Frontal plane knee alignment: a call for standardized measurement. *J. Rheumatol.* 34:1796–801
7. Dossett HG, Swartz GJ, Estrada N a, LeFevre GW, Kwasman BG (2012) Kinematically versus mechanically aligned total knee arthroplasty. *Orthopedics* 35:e160–9
8. Ewald FC (1989) The Knee Society total knee arthroplasty roentgenographic evaluation and scoring system. *Clin. Orthop. Relat. Res.* 9–12
9. Fang DM, Ritter MA, Davis KE (2009) Coronal alignment in total knee arthroplasty: just how important is it? *J. Arthroplasty Elsevier B.V.* 24:39–43
10. Howell SM, Howell SJ, Kuznik KT, Cohen J, Hull ML (2013) Does a kinematically aligned total knee arthroplasty restore function without failure regardless of alignment category? *Clin. Orthop. Relat. Res.* 471:1000–7
11. Lotke PA, Ecker ML (1977) Influence of positioning of prosthesis in total knee replacement. *J. Bone Joint Surg. Am.* 59:77–9
12. Luyckx T, Peeters T, Vandenuecker H, Victor J, Bellemans J (2012) Is adapted measured resection superior to gap-balancing in determining femoral component rotation in total knee replacement? *J. Bone Joint Surg. Br. British Editorial Society of Bone and Joint Surgery* 94:1271–6
13. Luyckx T, Vanhoorebeeck F, Bellemans J (2014) Should we aim at undercorrection when doing a total knee arthroplasty? *Knee Surg. Sports Traumatol. Arthrosc.*
14. Magnussen RA, Weppe F, Demey G, Servien E, Lustig S (2011) Residual varus alignment does not compromise results of TKAs in patients with preoperative varus. *Clin. Orthop. Relat. Res.* 469:3443–50
15. Matziolis G, Adam J, Perka C (2010) Varus malalignment has no influence on clinical outcome in midterm follow-up after total knee replacement. *Arch. Orthop. Trauma Surg.* 130:1487–91
16. Paley D (2002) *Principles of Deformity Correction.* Springer Berlin Heidelberg, Berlin, Heidelberg, pp 1–60
17. Parratte S, Pagnano MW, Trousdale RT, Berry DJ (2010) Effect of postoperative mechanical axis alignment on the fifteen-year survival of modern, cemented total knee replacements. *J. Bone Joint Surg. Am.* 92:2143–9
18. Ritter MA, Davis KE, Meding JB, Pierson JL, Berend ME, Malinzak RA (2011) The effect of alignment and BMI on failure of total knee replacement. *J. Bone Joint Surg. Am.* 93:1588–96
19. Ritter MA, Faris PM, Keating EM, Meding JB (1994) Postoperative alignment of total knee replacement. Its effect on survival. *Clin. Orthop. Relat. Res.* 153–6
20. Srivastava A, Lee GY, Steklov N, Colwell CW, Ezzet KA, D'Lima DD (2012) Effect of tibial component varus on wear in total knee arthroplasty. *Knee* 19:560–563
21. Tew M, Waugh W (1985) Tibiofemoral alignment and the results of knee replacement. *J. Bone Joint Surg. Br.* 67:551–6
22. Vanlommel L, Vanlommel J, Claes S, Bellemans J (2013) Slight undercorrection following total knee arthroplasty results in superior clinical outcomes in varus knees. *Knee Surg. Sports Traumatol. Arthrosc.* 21:2325–30

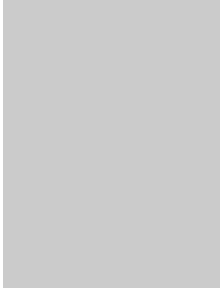


# **CHAPTER 5:**

## **CONCLUDING DISCUSSION AND FUTURE PERSPECTIVES**

---

**5**



# CHAPTER 5: CONCLUDING DISCUSSION AND FUTURE PERSPECTIVES

---

The purpose of this work was to improve the understanding of the geometry of the tibio-femoral joint interface of the native and the replaced knee. To describe the joint interface, the tangent to the tibial and femoral joint surface was used. This tangent was termed the joint line. In the first part, we described the position and orientation of the joint line in the coronal and axial plane of the native knee. We also identified some of its determinants. In the second part, we investigated the biomechanical effect of raising the level of the joint line in total knee arthroplasty (TKA) on the patellofemoral joint and on the tibio-femoral stability. And in the third part, we investigated the orientation of the joint line in the replaced knee and its effect on limb alignment and clinical outcome.

We are well aware of the fact that the use of the joint line to describe the geometry of the joint surfaces poses some conceptual restrictions that are inherent to such an approach. First of all, it is a dimensional reduction of the three-dimensional reality. Studying the joint line in 2 dimensions instead of 3 had the advantage of practicality in use, as plain radiographs are currently still the most common imaging source. Nevertheless, we believe that studying the 2-D joint line in the three planes (frontal, sagittal and axial) can provide a good approximation of the 3-D reality.

The second major restriction was that the joint line was mostly described from a static point of view with the knee in extension. It is however a dynamic structure and joint motion will alter the position of the joint line in the 3-D space. Knowledge of both knee kinetics and kinematics is important to understand the changing position of the knee joint line throughout the range of motion. With the development of our geometrical model in chapter 3 paragraph 3.4, we tried to provide a dynamic insight on the tibio-femoral joint stability by stressing the importance of joint motion. Our major recommendation based on these findings was therefore that during TKA, joint stability should be evaluated throughout the whole range of motion instead of only at 0° and 90° of flexion.

One should bear in mind these conceptual restrictions while interpreting this work. Doing so will enlighten the strength of certain aspects of it.

For future research, a technologic leap forward is needed to provide us with 3-D imaging modalities. Those modalities are not far from becoming available. We think of the EOS® system that provides a weightbearing 3-D reconstruction of the entire lower limb by a low dose 2-D scannogram [7]. But also other imaging modalities are emerging. This we certainly enhance our insights in the 3-D morphology of the tibio-femoral joint surface and its determinants. Still, this will only provide us static information. In-vivo dynamic 3-D imaging modalities are being developed but are not readily available in our clinical practice. They are indispensable for the next step in our understanding of the knee joint.

## HYPOTHESIS TESTING.

1. THE ADDUCTOR RATIO IS AN ACCURATE AND RELIABLE TOOL TO DETERMINE THE LEVEL OF THE MEDIAL JOINT LINE IN THE CORONAL PLANE.

It might seem trivial to measure the position of the joint line in the coronal plane as many other researchers have done this already. However, many different measurement methods (plain X-ray, CT-scan, MRI) and many different landmarks were used in the past. We were the first ones to do these measurements on full-limb standing radiographs. The radiographs were obtained from healthy volunteers and provided us with information on the joint line of the 'normal' knee. Second, the radiographs were calibrated which makes the values directly applicable in clinical practice. Third, all femoral and tibial landmarks around the knee were measured. As such, we provided a very complete assessment of the position of the tibio-femoral joint line in the coronal plane in the normal knee.

A better knowledge of the position of the native joint line in the frontal plane is of major importance for revision TKA. In contrast to primary TKA, the distal femoral surface is no longer available as landmark for joint surface reconstruction. The surgeon will therefore typically rely on some femoral and tibial bony landmarks around the knee. The medial epicondyle, the lateral epicondyle and the tip of the fibular head are the most frequently used ones. Those landmarks are difficult to localize intra-operative. Moreover, the distances used are average values, which show wide variation in the population. We were able to show that an important part of that variation can be attributed to the femoral width and thus the size of the knee. By dividing these absolute distances by the femoral width, a size independent ratio is created. We showed that the correlation with the femoral width was the strongest for the distance from the adductor tubercle to the joint line and that as a consequence the 'adductor ratio' showed the least variability. Apart from less variability, the



adductor tubercle has the advantage that it can be localized more easily both on radiographs and intra-operatively and that it remains available in heavy revision cases where the epicondyles are no longer there. It was therefore found to be a valuable tool for joint line reconstruction in revision TKA.

## 2. THE ORIENTATION OF THE JOINT LINE IN THE OSTEO-ARTHRITIC KNEE IS UNCHANGED BY THE OSTEO-ARTHRITIC PROCESS.

Apart from its position in relationship to the bony landmarks around the knee, the orientation is the second important parameters of the joint line in the coronal plane. It is generally accepted that the joint line has a 3° varus inclination relative to the mechanical axis of the lower limb (HKA-angle) [6]. The biomechanical advantage of this varus inclination is that it puts the joint line parallel to the ground during stance. However, this is only true for neutrally aligned knees ( $-3^\circ < \text{HKA} < 3^\circ$ ). An important fraction (27%) of the normal population has a hip-knee-ankle (HKA) angle that is not neutral but in varus or valgus [1]. In those knees, the joint line (JL) orientation is also significantly different. We found that the typical varus knee had a varus tibial JL (on average 5°) with a perpendicular femoral JL. Valgus knees had a perpendicular tibial JL with a valgus femoral JL (on average -5°). So the classic paradigm of the 3° varus inclination of the joint line needs to be revised. It is an average value that might not suit an individual patient.

Second important observation was that there were no significant differences between the orientation of the JL in the normal and the osteo-arthritis (OA) varus and valgus knee. This means that bone loss was minimal and that the joint line of the OA knee is a reliable landmark for anatomic joint line reconstruction in TKA.

A better understanding of the orientation of the tibial and femoral joint line is important as they determine limb alignment:  $\text{HKA-angle} = \text{femoral joint line angle (FJLA)} + \text{tibial joint line angle (TJLA)} + \text{joint line convergence angle (JLCA)}$  [3]. The significant increase in HKA-angle with the progression from normal to OA was in our series solely the consequence of an increase in the JLCA. This angle represents the divergence of the femoral and tibial joint surfaces and is the consequence of cartilage wear and/or joint space opening.

These findings also provide a more profound insight in the effect of the changes in joint line orientation induced by TKA. Currently, a one-size fits all approach is advocated in terms of alignment: the mechanical alignment. Irrespective to the native joint line orientation, a perpendicular position of the femoral and tibial component relative to the mechanical axis is advocated. This approach can create important strain in the soft tissue envelope of the knee by overstuffing certain compartments. A more anatomical joint line orientation could reduce these strains. In a varus knee, this means

accepting a slight varus of the tibial component. In a valgus knee, it implies a slight valgus of the femoral component. In a neutral knee, it means a combination of both. Concerns have been raised about putting a tibial component in slight varus. We share these concerns in a varus knee. However, the varus knees only represent 55% of our patients. An important fraction (45%) of our patients do not have pre-operative varus. In a neutrally aligned knee, we therefore question the benefit of changing the joint line orientation, as an alignment correction is not the target in these cases. These patients could benefit from a more anatomical approach.

Independently of the alignment target (mechanical vs. anatomical), recognising the joint line configuration (valgus vs. neutral vs. varus) of an individual knee before surgery is of major importance. It will allow the surgeon to predict the effect of certain surgical decisions on the tension in the soft tissue envelope. From a conceptual point of view, shifting away from the one-size fits all approach to a more individualised alignment would certainly make sense.

### 3. THE ORIENTATION OF THE JOINT LINE IN THE AXIAL PLANE IS RELATED TO THE CORONAL ALIGNMENT.

Joint line orientation in the axial plane remains a difficult parameter to understand. Many surgeons recognize that the alignment target of a TKA in the axial plane is a prosthetic joint line parallel to the surgical transepicondylar axis (sTEA) as the sTEA is known to approximate the true flexion-extension axis of the knee [2]. Surgeons advocating a measured resection technique will use the sTEA intra-operatively to determine the rotation of the femoral component. Others will use a secondary reference axis to locate the sTEA. The posterior condyles form such an axis. The advantage of using the posterior condyles is that in contrast to the sTEA, they are easy to localize intra-operatively. However, despite the fact that they are on average 3° internally rotated relative to the sTEA, this relationship is not fixed and a wide range of values is reported in literature [8]. We were able to demonstrate that in the osteo-arthritic knee, the sTEA is on average 1.6° internally rotated. Moreover, this value was related to the coronal alignment with a significant difference between valgus, neutral and varus knees. Taking this relationship into account can significantly improve the accuracy of a 'classic' measured resection technique. Using a standard 3° external rotation relative to the posterior condylar line in a varus knee might lead to excessive external rotation of the femoral component. With many instrumentation systems, increasing the external rotation will increase the thickness of the posteromedial resection. By doing this, the postero-medial joint line is raised and flexion instability could occur.

Setting the rotational alignment of the femoral component based on a pre-operative CT scan was termed 'adapted' measured resection. It represents an individualised approach towards femoral component rotation in which the rotational alignment is tailored to the patient's original anatomy. In a prospective controlled trial, we compared this new technique with a gap-balancing approach in terms of rotation of the femoral component. We concluded that both techniques were equally reliable and accurate in determining femoral component rotation in TKA. There was a tendency towards more external rotation in the gap-balancing group, but this difference was not statistically significant. The number of outliers for our 'adapted' measured resection technique was also much lower than reported in the literature. In this respect, our individualised approach did prove its value.

#### 4. JOINT LINE ELEVATION CAUSES SIGNIFICANT LAXITY IN MID-FLEXION AND HIGH MCL STRAINS IN DEEP FLEXION.

We performed 3 different ex-vivo experiments in which the tibio-femoral joint line was raised.

In the first experiment, we focused on the patellofemoral joint line to mimic the effect of a distal or proximal shift of the tibio-femoral joint line. The tendofemoral contact and the patellar lever arm were identified as the two important determinants of the patello-femoral contact force and pressure. Patella baja increased the contact pressures in early flexion; patella alta increased the contact forces in deeper flexion. The normal patella height represented the optimal balance between the two with the lowest average contact pressure throughout the whole range of motion.

In the next two experiments, we were able to show that joint line elevation caused higher strains in the sMCL in deep flexion on the one side, and significant mid-flexion laxity on the other side. Restoration of the medial distal and posterior joint line was found to be the essential prerequisite for normal joint stability.

Apart from that, the first of these experiments (chapter 3, paragraph 3.2.2) also revealed a significant increase in strain in the sMCL at 90° of flexion and beyond and a decrease of the maximal passive knee flexion in the knees with the restored medial joint line (TKA0) compared to the native knee. In other words, a TKA in an 'optimal' position did also increase the strain in the soft tissue envelope. We believe that the explanation for this can be found in the fact that an equal tension on the flexion and extension gap was set as target for the TKA0 position. In practice, this often meant a postero-medial resection of 7 or 8 mm. As such, more metal was put back in the flexion space than the bone that was removed, as the implant thickness equalled 9 mm. This caused a relative overstuffing of the

flexion space with higher sMCL strains and a decrease in maximal passive knee flexion as a consequence. This contrasts the second experiment (chapter 3, paragraph 3.3) where we performed a medial distal and posterior resection of 9 mm in all knees. As a consequence, the natural laxity of the knee with increasing laxity in flexion was reproduced.

Based on the results of these experiments, we question the balanced flexion-extension gap paradigm for 2 major reasons. First of all, an approach in which the extension gap must equal the flexion gap does not take into account the natural laxity of the knee in flexion. The problem becomes even worse in a posterior stabilised (PS) TKA as posterior cruciate ligament (PCL) resection will increase the flexion space even more. If the surgeon wants to equal flexion and extension gap, he only has 2 options. The first option is to increase the extension space by re-cutting the distal femur. This option will raise the joint line and can introduce mid-flexion instability as shown in chapter 3 paragraph 3.3. The second option is to upsize the femoral component and thus add a few millimetres more metal to the flexion space than the bone that was removed. This option will cause a relative overstuffing of the flexion space and increase the strain in the sMCL in deep flexion as shown in chapter 3 paragraph 3.2. We want to introduce a third option. This option is to restore the level of the distal medial and the distal posterior joint line to its original position by applying a strict measured resection technique. This will restore the natural laxity of the knee in flexion and reproduce normal joint stability throughout the range of motion as showed in chapter 3 paragraph 3.3.

The second major problem with the flexion-extension gap paradigm is that it does not provide an explanation for the observed mid-flexion laxity as this occurred despite a balanced flexion and extension gap. The flexion extension gap theory is a simplified one-dimensional model that despite the advantage of being easy in use, has its limitations. In an attempt to provide a more profound insight, we developed a 2-dimensional geometrical model (chapter 3, paragraph 3.4). Adding an extra dimension allowed us to explain the occurrence of the mid-flexion instability despite a balanced flexion and extension gap, based on a change in isometry of the sMCL.

Based on all these findings, we believe that restoration of the medial joint line, both distal and posterior, should become the target that precedes all other principles in TKA.

## 5. THE JOINT LINE ORIENTATION OF THE KNEE INFLUENCES POSTOPERATIVE ALIGNMENT AND CLINICAL OUTCOME IN TKA

We identified a bias toward undercorrection of the alignment in the coronal plane that is present with current instrumentation techniques in mechanically aligned TKA. Stratification based on the pre-operative alignment revealed that this undercorrection was done differently in terms of orientation of the components in the different alignment categories. The undercorrection was located at the site of the major deformity. Conforming our data in Chapter 2 paragraph 2.1.2, this was found to be the femur in valgus knee and the tibia in varus knees.

The next step was to investigate how this undercorrection affected clinical outcome. In a cohort of patients with varus osteo-arthritis, we investigated the influence of component alignment on clinical outcome. It was shown that undercorrection did indeed improve patient outcome. But it should be done carefully avoiding a combination of varus alignment of the femoral and tibial component of greater than 2°. The best clinical results were obtained with a tibial component in slight varus (<2°) combined with a HKA-angle in mild varus (3-6°). In contrast to the intuitive feeling of many surgeons that a varus femoral component with a neutral tibial component lead to the best result in varus knees, it was shown that varus alignment of > 2° of the femoral component was also associated with a worse clinical outcome.

Changing the alignment and joint line orientation comes at a cost and should therefore be done with great care. The generalised approach that is currently advocated with a perfect neutral HKA-angle as the holy grail should therefore be questioned. Patient might benefit from a more individualised approach, taking into account their original joint line orientation. Such an approach should be accompanied by an increase in surgical accuracy. If not, an increase in the number of alignment outliers will be the consequence. Where the initial enthusiasm for computer assisted surgical navigation has faded, these insights might spark its revival. The fact that computer navigation never succeeded in improving patient function after TKA does say a lot more about the alignment goal (i.e. mechanical alignment) that was set than about the navigation itself. The patient will therefore only benefit from the improved surgical precision offered by the surgical navigation if the right target is set. We believe that based on these data, the target should be more anatomical.

## FUTURE PERSPECTIVES

We started off with the idea that the best way to gain a better insight in the position and orientation of the joint line in the replaced knee is by improving the understanding of the native situation. These data made us realise that a lot of changes to the natural situation are introduced by knee replacement surgery. Moreover, we came to realise that many of the targets set for a knee replacement in term of position and orientation of the components are based on average values. From a biometrical point of view, those average values show a wide variation in the population and might not suit an individual patient. From a biomechanical point of view, the best position of the medial joint line in terms of strain in the MCL and joint stability was shown to be the native one. And from a clinical point of view, a more anatomic orientation of the joint line did improve patient outcome. The less joint line changes, the better, so it seems.

The aim of knee replacement surgery is apart from a restoration of the articular surface, also a correction of the alignment (= mechanical alignment) [4, 5]. Part of the problems arises from the fact that this so-called malalignment is situated extra-articular but is corrected intra-articular. In uni-compartmental replacement, no alignment correction is pursued and yet, functional results are much better. If we want to achieve the same functional results as with the uni-compartmental replacement, we should apply some of its principles to TKA.

Two major paradigms are ruling knee arthroplasty for more than 30 years. The flexion-extension gap theory and the mechanical alignment. During those years, major technological advancements and design improvements were not able to improve patients' function and satisfaction after TKA (see introduction). It's about time that the only 2 things that weren't changed during those years are now challenged. Instead of these paradigms, based on our data, we propose an individualised approach in which the targets are: 1. reconstruction of the medial joint line to its original level; 2. anatomic joint line orientation.

Both of these principles are joined in the so-called 'kinematic' or 'anatomic' alignment. The early functional results of the technique are very promising. A recent level 1 prospective randomised controlled trial (RCT) was able to show a better patient function using this approach. Based on these results, we are currently conducting our own level 1 RCT comparing 'mechanical' alignment with 'kinematic' alignment. The first results should be expected within one year.

It would be the most edifying form of gratification to me, if the insights that originate from this work and that have led to this RCT would indeed translate into improved functional outcome in our patients. Then, I would be a truly happy orthopaedic surgeon.

## REFERENCES

1. Bellemans J, Colyn W, Vandenneucker H, Victor J (2012) The Chitranjan Ranawat award: is neutral mechanical alignment normal for all patients? The concept of constitutional varus. *Clin. Orthop. Relat. Res.* 470:45–53
2. Churchill DL, Incavo SJ, Johnson CC, Beynnon BD (1998) The transepicondylar axis approximates the optimal flexion axis of the knee. *Clin Orthop Relat Res* 111–118
3. Cooke TD V, Sled EA, Scudamore RA (2007) Frontal plane knee alignment: a call for standardized measurement. *J. Rheumatol.* 34:1796–801
4. Freeman MA, Swanson SA, Todd RC (1973) Total replacement of the knee using the Freeman-Swanson knee prosthesis. *Clin Orthop Relat Res* 153–170
5. Insall J, Ranawat CS, Scott WN, Walker P (2001) Total condylar knee replacement: preliminary report. 1976. *Clin Orthop Relat Res* 3–6
6. Kapandji I (1970) *The Physiology of the Joints*. Ed 2.
7. Than P, Szuper K, Somoskeöy S, Warta V, Illés T (2011) Geometrical values of the normal and arthritic hip and knee detected with the EOS imaging system. *Int. Orthop.*
8. Victor J (2009) Rotational alignment of the distal femur: a literature review. *Orthop. Traumatol. Surg. Res.* 95:365–72



# SUMMARY

---

Total knee arthroplasty (TKA) is generally considered a very successful procedure to treat patients with end-stage osteoarthritis (OA) of the knee. It continues to enhance the quality of life and alleviate pain for a large number of patients. Studies have shown a high survivorship for TKA, with more than 90% of the implants being in place at 10 years and beyond. However, recent studies show us that as many as 15% to 20% of patients either feel dissatisfied or very dissatisfied about their TKA and only 60% report their knee to feel normal. A good survival therefore does not equal a good function of the implant. Despite improvements in design and material, patient satisfaction rates were remarkable consistent the last 15 years suggesting that innovation in TKA technology has had little effect. At the same time, recent evidence is showing us the importance of the surgeon himself as a variable. How an implant is inserted can be considered of equal, if not of greater, importance than the implants itself. However, despite the high number of TKA's that are performed every year, there is still no consensus on what the 'optimal' position for a TKA might be.

This work was therefore a quest for the 'optimal' position of the artificial tibio-femoral joint interface in an attempt to improve function and satisfaction in our patients. The tibio-femoral joint line was used as a tool to describe the position and orientation of that joint interface in the three-dimensional space.

The understanding of the joint line in TKA benefits from a better insight in the joint line in the normal knee. That's why the first part of this work aimed at improving the current knowledge of the position and orientation of the native knee. The focus was on the coronal and axial plane. We were able to define the joint line more comprehensive and with greater precision than before. Moreover, we identified some of its determinants. These data are important for joint line reconstruction in primary and revision TKA and allow us a more individualized approach of our patients.

Stability of a TKA is crucial for a good functional outcome. In the second part of this work we focused on the biomechanical effect of a proximal shift of the tibiofemoral joint line on joint stability. In three different ex-vivo experiments, we were able to show that joint line proximalisation causes mid-flexion instability on the one side and higher strains in the medial collateral ligament and higher forces on the patella on the other side. The only way to reproduce the natural stability of the knee with a TKA is to restore the level of the distal and posterior medial joint line at their original level. In

other words, the restoration of the level of the medial joint line is an essential prerequisite for normal joint stability in TKA. Based on these results, we developed and validated a geometrical model of the knee that, in contrast to the classic flexion-extension gap paradigm, provides an explanation for our findings. This geometrical model enables the surgeon to predict the effect of certain intra-operative decisions on joint stability and ligament tension, hereby improving component position.

In the third part of this work, we studied the orientation of the joint line in the replaced knee. We noticed that when doing a TKA with conventional instruments, an unintentional bias towards undercorrection of the pre-operative deformity exists and that this undercorrection is determined by the pre-operative alignment. As a result, the orientation of the joint line became more anatomical.

In the second part, we investigated the effect of this undercorrection on the clinical outcome in our patients and found that slight undercorrection and thus a more anatomical joint line orientation did indeed improve patient outcome.

The results of both the anatomical, biomechanical and clinical part of this research strengthen the idea that a more anatomical position and orientation should be the target in TKA and that only an individualised approach will improve the functional results in our patients.

# SAMENVATTING

---

De totale knieprothese (TKP) is een heel succesvolle behandeling voor patiënten met terminale knie-artrose. Ze biedt een efficiënte oplossing voor de invaliderende pijn en verbetert zo jaarlijks aanzienlijk de kwaliteit van leven van honderdduizenden mensen. Wetenschappelijke studies bewijzen de excellente duurzaamheid van de TKP op lange termijn waarbij meer dan 90% van de implantaten nog functioneren na 10 jaar en meer. Desalniettemin leren recente studies ons dat 15% tot 20% van de patiënten niet tevreden is over hun TKP en dat slechts 60% vindt dat hun knie normaal aanvoelt. Een grote duurzaamheid van het implantaat betekent met andere woorden nog geen goede functie ervan. Ondanks de vooruitgang die geboekt werd in het design en het materiaal van de prothesen over de laatste 15 jaar, bleef de patiënt tevredenheid gedurende die periode opmerkelijk constant. Dit suggereert dat die technologische vooruitgang relatief weinig invloed heeft gehad op het functioneel resultaat bij onze patiënten. Terzelfdertijd is er meer en meer evidentie die het belang aantoont van de positie waarin de prothese wordt geplaatst. Mogelijk is dit zelfs de meest bepalende factor voor de functionaliteit van de knie. Het is dan ook opmerkelijk te noemen dat ondanks het grote aantal TKP's die er jaarlijks geplaatst worden, er nog steeds geen consensus bestaat over wat de 'optimale' positie van een TKP dan wel mag zijn.

Dit werk was dan ook mijn zoektocht naar de 'optimale' positie van het kunst-gewricht met als doel de functionaliteit en de tevredenheid van onze patiënten met een TKP te verbeteren. De tibio-femorale 'joint line' of 'gewrichtslijn' werd gebruikt als middel om de positie en de oriëntatie van het gewrichtsoppervlak in de 3-dimensionele ruimte te beschrijven.

Een beter begrip van de joint line van een TKP begint met een beter inzicht in de joint line van de normale knie. Vandaar dat het eerste deel van dit werk focust op het vergroten van de huidige kennis over de positie en oriëntatie van de normale knie. Het frontale en het axiale vlak werden bestudeerd. Hierbij slaagden we erin om de joint line uitgebreider en met grotere accuraatheid in kaart te brengen dan tot nu toe het geval was. Bovendien identificeerden we een aantal van de bepalende factoren. Deze data zijn belangrijk voor het herstel van de joint line in primaire en revisie TKP chirurgie en zullen een meer geïndividualiseerde aanpak van onze patiënten mogelijk maken.

De stabiliteit van de knie wordt aanzien als een cruciale factor voor een goed functioneel resultaat na TKP. Dat is de reden waarom we in het tweede deel van dit werk het biomechanisch effect van een

proximale verschuiving van de joint line zijn gaan onderzoeken. Via 3 verschillende ex-vivo experimenten konden we aantonen dat joint line proximalisatie enerzijds een significante mid-flexie instabiliteit veroorzaakte en anderzijds aanleiding gaf tot een hogere spanning in het mediaal collateraal ligament en hogere krachten op de knieschijf. De enige manier om de normale stabiliteit van de knie te reproduceren met een TKP is door de distale en posterieure mediale joint line te herstellen op zijn origineel niveau. Het herstel van de mediale joint line is met andere woorden de absolute voorwaarde voor normale stabiliteit van de knie na TKP. Op basis van deze experimentele resultaten hebben we een geometrisch model van de knie ontwikkeld dat, in tegenstelling tot het klassieke 'flexion-extension gap' paradigma, een verklaring kan bieden voor de geobserveerde resultaten. Dit geometrisch model stelt de chirurg in staat om het effect van bepaalde intra-operatieve beslissingen op de ligamentaire spanning en de stabiliteit van de knie te verklaren en hierdoor de positie van het implantaat te verbeteren.

In het derde deel van dit werk hebben we ons gericht op de joint line na TKP. We stelden vast dat wanneer we een TKP doen met conventionele instrumenten, er een niet intentionele neiging tot onder-correctie van de pre-operatieve deformiteit bestaat en dat deze onder-correctie bepaalt wordt door het pre-operatieve alignement. Hierdoor bekwamen we een meer anatomische oriëntatie van de joint line na TKP. Vervolgens onderzochten we het effect van deze onder-correctie op het klinische resultaat bij onze patiënten. Hierbij vonden we dat een lichte onder-correctie, en dus een meer anatomische oriëntatie van de joint line inderdaad het klinische resultaat verbeterde.

De resultaten van zowel het anatomische, het biomechanische en het klinische deel van dit werk versteken de opvatting dat een meer anatomische positie en oriëntatie van de joint line het doel moeten zijn van knieprothese chirurgie en dat alleen een geïndividualiseerde aanpak de functionele resultaten van onze patiënten zal verbeteren.

# CURRICULUM VITAE

---

## PERSONAL INFORMATION

---

**Surname** LUYCKX

**First names** Thomas Pieter Johannes  
Fredericus

Address Kerkstraat 18A, 3060 Bertem

Mobile +32 473967200

E-mail luyckx.thomas@gmail.com

Date of birth 01/12/1983

Place of birth Poperinge

Nationality Belgian

Marital status Married to Els Viaene on 19 febr 2011  
Father of Emiel Luyckx (° 16/5/2014)



## EDUCATION

---

2011-present **PhD training in biomedical sciences, University of Leuven**

2004-2008 **Master of Medicine, University of Leuven, 2008**  
*Greatest distinction (86,02%)*

2001-2004 **Bachelor of Medicine, University of Leuven, Campus KULAK, 2004**  
*Great distinction*

1995-2001 **High School**  
Science-Mathematics  
Sint-Leocollege, Brugge

## DOCTORAL RESEARCH

---

2011-present *Department of Orthopaedic surgery*

*Project:* Geometry of the tibiofemoral joint line: what is the biomechanical and clinical impact of surgical modifications?

*Joint degree project* between the Catholic University Leuven and the University Ghent.

Promotor KU Leuven: Prof Dr J Bellemans and Prof Ph Debeer

Promotor UGent: Prof Dr J Victor

## ORTHOPAEDIC TRAINING

---

Officially approved training program as a full time resident with the following surgeons:

01/08/08 – 31/07/10	Heilig Hart Ziekenhuis, Roeselare	<b>P.Vuylsteke, MD</b>
01/08/10 – 31/07/11	Sint Lucas Ziekenhuis, Brugge	<b>J. Victor, MD, PhD</b>
01/08/11 - 30/09/12	University hospitals Leuven	<b>J. Bellemans, MD, PhD</b>
01/10/12 – 31/03/13	University hospital Ghent	<b>J. Victor, MD, PhD</b>
01/04/13 – 31/07/14	University hospitals Leuven	<b>J. Bellemans, MD, PhD</b>

Officially recongniced as doctor in the orthopaedic surgery and traumatology by the Belgian Ministry of Health Care 25 june 2014.

Identification number: 1-36780-87-480

Fellowship Knee surgery and Sports medicine at the University Hospitals, Pellenberg from 1/8/14 till 31/7/15.

## PUBLICATIONS

---

### **Papers in Peer reviewed Journals**

Management of full thickness rotator cuff tears. A survey amongst members of the Flemish Elbow and Shoulder Surgeons Society (FLESSS). **T Luyckx**, P DeBeer. *Acta Orthop Belg* 2010;76:14-21.

Return to work after arthroscopic subacromial decompression. L Luyckx, **T Luyckx**, P Donceel, P DeBeer. *Acta Orthop. Belg* 2011;77:737-742.

The Second fracture: a bony avulsion of the anterolateral ligament of the knee. S Claes, **T Luyckx**, E Vereecke, J Bellemans. *The Journal of Arthroscopic and Related Surgery* 2013;29(10),e86-e86.

Digital image correlation as a tool for three-dimensional strain analysis in human tendon tissue. **T Luyckx**, M Verstraete, K De Roo, W De Waele, J Bellemans, J Victor. *Journal of Experimental Orthopaedics* 2014 1:7

Is there a biomechanical explanation for anterior knee pain in patients with patella alta? Influence of patellar height on patellofemoral contact force, contact area and contact pressure. **T Luyckx**, K Didden, H. Vandenneucker, L. Labey, B. Innocenti, J. Bellemans. *J Bone Joint Surg [Br]* 2009;91-B:344-50.

Anteroposterior positioning of the tibial component and its effect on the mechanics of patellofemoral contact. K Didden, **T Luyckx**, H. Vandenneucker, L. Labey, B. Innocenti, J. Bellemans. *J Bone Joint Surg [Br]* 2010;92-B:1466-70.

Iliotibial band traction syndrome in guided motion TKA: A new clinical entity after TKA. L. Luyckx, **T Luyckx**, J Bellemans, J Victor. *Acta Orthop. Belg* 2010;76:507-512.

Is adapted measured resection superior over gap-balancing in determining femoral component in TKA? **T Luyckx**, T Peeters, H Vandenneucker, J Victor, J Bellemans. *J Bone Joint Surg [Br]* 2012;94:1271-6.

Coronal alignment is a predictor of the rotational geometry of the distal femur in the osteo-arthritic knee. **T Luyckx**, F Zambianchi, F Catani, J Bellemans, J Victor. *Knee Surg Sports Traumatol Arthrosc* 2013;21(10):2331-7.

Does a conservative tibial cut in conventional total knee arthroplasty violate the deep medial collateral ligament? M Maes, **T Luyckx**, J Bellemans. *Knee Surg Sports Traumatol Arthrosc*; published online 14 July 2013, doi:10.1007/s00167-013-2606-9

How to improve femoral component rotational alignment in computer-assisted TKA. F Zambianchi, **T Luyckx**, J Victor, V Digennaro, A Giorgini, F Catani. *Knee Surg Sports Traumatol Arthrosc*; published online 10 may 2014, doi:10.1007/s00167-014-3045-y

The role of the deep medial collateral ligament in controlling rotational stability of the knee. E Cavaignac, K Carpentier, R Pailhe, **T Luyckx**, J Bellemans. *Knee Surg Sports Traumatol Arthrosc*; published online 4 June 2014, doi 10.1007/s00167-014-3095-1

Should we aim at undercorrection when doing a TKA? **T Luyckx**, F Vanhoorebeeck J Bellemans. *Knee Surg Sports Traumatol Arthrosc* 2014; doi 10.1007/s00167-014-3185-0

The Adductor Ratio: a new tool for joint line reconstruction in revision TKA. **T Luyckx**, L Beckers, W Collyn, H Vandenneucker, J Bellemans. *Knee Surg Sports Traumatol Arthrosc* 2014; doi 10.1007/s00167-014-3211-2

Postural stability during the transition from double-leg stance to single-leg stance in anterior cruciate ligament injured subjects. B Dingenen, L Janssens, **T Luyckx**, Steven Claes, J Bellemans, F Staes. Clin. Biomech. 2015; doi 10.1016/j.clinbiomech.2015.01.002

### **Chapters in Books:**

**T Luyckx**, J Victor (2012) Alignment and biomechanics' : a surgeon's perspective. In: Thienpont E (ed) Improving Accuracy in Knee Arthroplasty, 1st edn. Ajanta, New Dehli, pp 85-94

### PRESENTATIONS AT INTERNATIONAL MEETINGS

---

SECEC 2008, Bruges, Belgium, *Poster presentation*

How do Flemish shoulder surgeons treat a full-thickness tear of the rotator cuff?

**T Luyckx**, P Debeer

6-8 April 2011: 30<sup>th</sup> SEROD meeting, San Sebastian, Spain, *Podium presentations*

Comparative knee kinematics. **T Luyckx**, J Victor

The extensor mechanism in the multi-revision setting. **T Luyckx**, J Victor

25-28 may 2011: GRECMIP Bruges, Belgium, *Podium presentation*

Arthroscopic arthrodesis of the ankle

**T Luyckx**, G Van Damme, P Deprez

Endoscopically assisted flexor hallucis longus transfer: description of a new technique

**T Luyckx**, G Van Damme, P Deprez

ESSKA 2012, Geneva, *Podium presentation*

Is adapted measured resection superior over gap-balancing in determining femoral component rotation in TKA?

**T Luyckx**, T Peeters, H Vandenneucker, J Victor, J Bellemans

AAOS 2013, Chicago *Poster presentation*

Is adapted measured resection superior over gap-balancing in determining femoral component rotation in TKA?

**T Luyckx**, T Peeters, H Vandenneucker, J Victor, J Bellemans

AAOS 2013, Chicago *Podium presentation*

Patient Specific Guides do not improve accuracy in TKA.

J Dujardin, **T Luyckx**, H Vandenneucker, J Bellemans, J Victor

ISAKOS 2013, Toronto *Podium presentation*

Is There A Relationship Between The Coronal Alignment And The Rotational Geometry Of The Distal Femur In The Osteo-Arthritic Knee?

**T Luyckx**, F Zambianchi, F Catani, J Bellemans, J Victor

ISAKOS 2013, Toronto *Podium presentation*

A Prospective Comparison Of Adapted Measured Resection Versus Gap-Balancing In Determining Femoral Component Rotation In TKA.

**T Luyckx**, F Zambianchi, F Catani, J Bellemans, J Victor



ISAKOS 2013, Toronto *Podium presentation*

The Second Fracture: Just An X-Ray Clue For A Ruptured Anterior Cruciate Ligament?

S Claes, E Vereecke, **T Luyckx**, J Victor, P Verdonk, J Bellemans

SIGASCOT 2013, Catania, *Podium presentation*

The alignment in the osteo-arthritic knee: progression from “neutral” tot “natural”

**T Luyckx**

PATRAS 2013, Greece, *poster presentation*

ACL Preserving Total Knee Arthroplasty Can Improve Knee Stability

C. Halewood, **T. Luyckx**, S. Claes, J. Victor, J. Bellemans, C. Lowry, D. Simpson, S. Collins, A.A. Amis

ISTA 2013, Palm Beach, Florida, *Podium presentation*

The adductor ratio : a new tool for joint line reconstruction in revision TKA.

**T Luyckx**, L Beckers, W Colyn, J Bellemans

ISTA 2013, Palm Beach, Florida, *Poster presentation*

The effect of single radius TKA implantation and joint line proximalisation on strain distribution in the superficial medial collateral ligament.

**T Luyckx**, K De Roo, M Verstraete, J Bellemans, J Victor

ISTA 2013, Palm Beach, Florida, *Podium presentation*

Validation of Digital Image Correlation as tool for non-contact 3D strain analysis in human tendon tissue.

**T Luyckx**, M Verstraete, K De Roo, W Dewaele, J Bellemans, J Victor

AAOS 2014, New Orleans, *Podium presentation*

The adductor ratio: a new tool for joint line reconstruction in revision TKA.

**T Luyckx**, L Beckers, W Colyn, J Bellemans

EFFORT 2014, London, *Poster presentation*

Joint Line Proximalisation In TKA Causes Significant Strain Elevation In The sMCL.

K De Roo, **T Luyckx**, M Verstraete, W Dewaele, J Bellemans, J Victor

EORS 2014, Nantes, *Podium presentation*

Full field strain evaluation of sMCL during ex-vivo experiments

M Verstraete, **T Luyckx**, K De Roo, W Dewaele, J Bellemans, J Victor

AAOS 2015, Las Vegas, *accepted as Podium presentation*

Influence of component alignment on clinical outcome after total knee arthroplasty in varus knees.

**T Luyckx**, F Matassi, L Vanlommel, J Bellemans

## AWARDS AT INTERNATIONAL MEETINGS

---

2012: Young Researcher award at the 15th ESSKA conference, Geneva: 2000 euro

## MEMBERSHIPS

---

Board member of the BOTRA (Belgium Orthopaedics and Trauma Residents Association) from September 2011 till July 2014

Member of the BVOT (Belgium society for Orthopaedic surgeons)

Member of the BKS (Belgium Knee Society)

Member of the ESSKA (European Society for Sports Medicine and Knee surgery)

Member of ICRJ (International congress for Joint reconstruction)

# DANKWOORD

---

Hoeveel dagen heb ik niet gesleten achter dit bureau terwijl ik mijn hoofd aan het breken was op hypothesen, aan het wroeten was in data en aan het worstelen was met conclusies. Ik ben dan ook in de eerste plaats heel blij dat het eindelijk allemaal achter de rug is. Terzelfdertijd ben ik ook oprechte dankbaarheid verschuldigd aan de vele mensen die me bij mijn thesis geholpen hebben. Want het zal iedereen ondertussen wel duidelijk zijn dat dit soort werk niet tot stand komt als het product van een enkeling.

In de eerste plaats wil ik mijn promotoren en orthopedische ‘godfathers’ Prof. Dr Jan Victor en Prof. Dr. Johan Bellemans bedanken. Jullie hebben me begeleid vanaf mijn eerste stappen in de orthopedische wereld en mee op sleeptouw genomen in dit wetenschappelijke avontuur. Jullie leerden me niet alleen de knepen van het vak maar bezorgden me bovendien een constante prikkel naar ‘meer’ en ‘beter’. Jullie aanstekelijk enthousiasme, jullie onstilbare drive en jullie torenhoog engagement zijn voor mij een voorbeeld. Het was voor mij dan ook een waar voorrecht om met jullie twee opleiders van wereldklasse te hebben.

Ook Prof. Dr. Philippe Debeer wil ik in bijzonder bedanken om het promotorschap van het laatste deel van dit project op zich te nemen, mee te begeleiden en zo tot een goed einde te brengen.

Verder wil ik de leden van de jury bedanken: Prof. Dr. Peers, Prof. Dr. R. Westhovens, Dr. Catherine Van Der Straeten, Mr. Jacob Sukumaran, Prof. Dr. A Wymenga en Prof. Dr. F. Catani. Jullie name jullie taak als jurylid zeer ter harte. De kwaliteit van jullie commentaren en de verschillende invalshoeken ervan hebben mijn werk dan ook duidelijk verbeterd. More specifically, I would like to thank prof Wymenga en prof Catani for finding time in their busy schedule to travel from the Netherlands and Italy to Belgium. Thank you.

Iedereen die ooit een experimentele studie heeft uitgevoerd, weet dat de dagen in het labo met grote ups en downs verlopen. Ik heb hierbij steeds het geluk gehad mijn omringd te weten met een aantal uitzonderlijk intelligente mensen. Hun bijdrage kan dan ook niet genoeg benadrukt worden.

In het bijzonder wil ik Matthias Verstraete en Karel De Roo bedanken voor hun bijdrage aan de experimenten in Gent. Karel en Matthias, onze tijd in het labo was legendarisch. Het heeft mij niet alleen een hele hoop data opgeleverd, maar heb ik er ook 2 vrienden aan over gehouden. Bedankt.

Ook aan de KULAK kon ik beroep doen op een uitermate sterk team. Ik wil in het bijzonder Prof. Evie Vereecke bedanken voor haar bijdrage. Evie, je scherpzinnige geest en praktische raad heb je mij

verschillende keren gered. Ook jullie bijdrage, Lennart Scheys, Maarten Boonen en Jan Dauwe was van onschatbare waarde. Verder ben ik ook dank verschuldigd aan de mensen van Corin, Cormed en Brainlab voor hun logistieke steun. Ze vonden in hun drukke agenda nog de tijd om met een auto vol bakken prothesemateriaal naar het labo te komen en daar dan de dag te spenderen tussen de lijken. Dank u!

Mijn PhD liep samen met mijn klinische opleiding als orthopedisch chirurg in Pellenberg. Niet altijd een evidente combinatie. Ik heb mijn tijd daar nochtans als een bijzonder aangename periode ervaren. Ik wil dan ook iedereen bedanken waar ik de afgelopen jaren mee mocht samenwerken: alle stafleden, de verpleging van de operatiezaal, het CDC en de verpleegeenheden, de mensen van het secretariaat, de kiné, de collega's assistenten en co-assistenten. Het is steeds een echt genoeg geweest om met jullie te kunnen werken. Heel specifiek wil ik ook jou bedanken, Steven Claes, voor jouw steun en advies in de afgelopen jaren. Thanks buddy.

Verder wil ik mijn vrienden en familie bedanken. Het feit dat jullie zo talrijk aanwezig zijn, zegt genoeg. Jullie niet aflatende steun en vertrouwen zijn het fundament waarop dit werk gebouwd is. Bovendien zorgen jullie op tijd en stond voor broodnodige afleiding en zetten alles weer in het juiste perspectief.

Ik heb het voorrecht gehad om op te groeien in een heel warm nest. Mama, papa: jullie zijn mijn trouwste supporters. Ook als het minder gaat, stuwen jullie me terug voorruit. Ik kan jullie hiervoor niet genoeg bedanken. Jullie nuchtere kijk op het leven, jullie doorzettingsvermogen en jullie gezond verstand zijn bovendien een voorbeeld voor mij. En ook mijn broers Lucas en Matthias stonden en staan altijd voor me klaar. Het doet deugd te weten dat ik altijd op jullie kan rekenen. Dikke merci!

En tot slot moet ik jou bedanken, Els. Al weet ik dat ik met woorden sowieso tekort zal schieten. Ik wil je bedanken voor het onmetelijk begrip, voor de grenzeloze steun, voor het oneindig vertrouwen en voor de onvoorwaardelijke liefde die ik de afgelopen jaren mocht ervaren. Emiel, je beseft het allemaal nog niet goed, maar je kan je geen betere mama wensen. En ik mijn geen mooiere zoon. Jullie zijn alles voor mij!

Bedankt!

Thomas Luyckx

Bertem, maart 2015

*"The past is a ghost, the future a dream and all we ever have is now."*  
Bill Cosby

