



Strathprints Institutional Repository

Bonivento, C. and Grimble, M.J. and Giovanini, L. and Monari, M. and Paoli, A. (2007) *State and parameter estimation approach to monitoring AGR nuclear core*. In: A Tribute to Antonio Lepschy, Eds: G.Picci and M.Valcher. Edizioni Libreria Progetto Padova, pp. 31-56.

Strathprints is designed to allow users to access the research output of the University of Strathclyde. Copyright © and Moral Rights for the papers on this site are retained by the individual authors and/or other copyright owners. You may not engage in further distribution of the material for any profitmaking activities or any commercial gain. You may freely distribute both the url (<http://strathprints.strath.ac.uk/>) and the content of this paper for research or study, educational, or not-for-profit purposes without prior permission or charge.

Any correspondence concerning this service should be sent to Strathprints administrator: <mailto:strathprints@strath.ac.uk>

State and parameter estimation approach to monitoring AGR nuclear core

Claudio Bonivento¹, Michael J. Grimble², Leonardo Giovanini³, Mattia Monari⁴, and Andrea Paoli⁵

¹ CASY-DEIS, University of Bologna, Italy
claudio.bonivento@unibo.it

² ICC, Strathclyde University of Glasgow, United Kingdom
m.grimble@eee.strath.ac.uk

³ ICC, Strathclyde University of Glasgow, United Kingdom
leonardo.giovanini@eee.strath.ac.uk

⁴ former visiting student at ICC, Strathclyde University of Glasgow, United Kingdom
mattia.monari@aliceposta.it

⁵ CASY-DEIS, University of Bologna, Italy andrea.paoli@unibo.it

This work is dedicated to the memory of professor and friend Antonio (Toni) Lepschy, University of Padua, who has played a key role in the Italian control community from dawn to our days with his deep culture, scientific influence and great humanity.

1 Introduction

This work concerns with the problem of monitoring an Advanced Gas-cooled Nuclear Reactor (AGR) core. This plant (figure 1) makes use of the heat given by the nuclear efficient reaction to produce electricity by means of steam turbines. These are driven by steam, which is heated, from the AGR gas using a heat exchanger. One of the advantages of a gas cooled reactor is the high temperature that the gas can achieve so that when it is used in conjunction with the heat exchanger and steamed turbine the thermal efficiency is very high.

In the United Kingdom the advanced gas-cooled reactor (AGR) nuclear power stations are approaching the end of their predicted operational life. The reactor core is composed of a hundreds of hollow graphite bricks (that acts as neutron moderator), and the graphite ages because of neutron irradiation and radiolytic oxidation causing distortion and potentially cracking of the bricks since it is impossible to repair or replace the graphite bricks the graphite core is one of the main components that determinate the operational life of

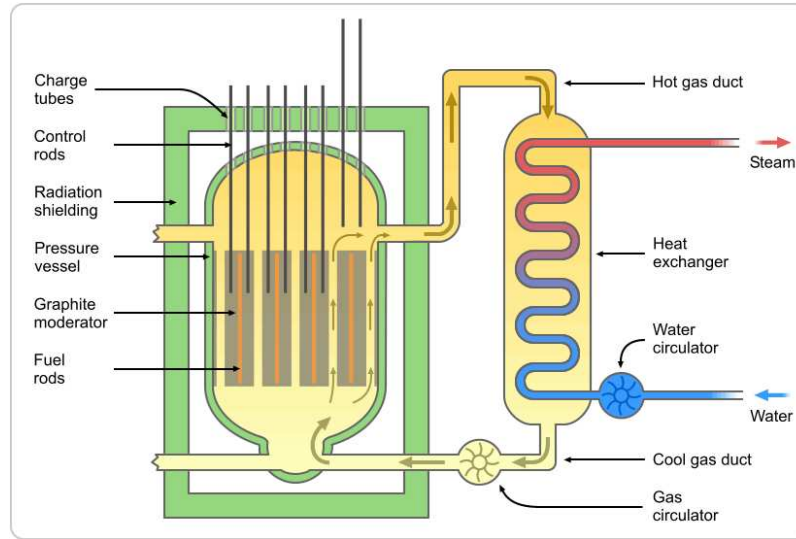

Fig. 1. Schematic diagram of an Advance Gas Cooled Reactor.

a nuclear station. In other terms the major factor that dictates the life of a nuclear power station is the condition of the graphite reactor core, which distort over time with prolonged exposure to heat and radiation.

Currently, it has been proposed to extend the operational lifetime of the nuclear plants if the distortions of the reactor cores are not as severe as initially predicted, and if it is possible to prove that the reactors are still safe to operate. From this, it is clear how important is to keep under monitoring the integrity of the plant and especially of the core; this is actually made possible by a routine performed during planned station outage. These outages occur roughly every three years and result in a large volume of detailed information collected by a system called *Channel Bore Monitoring Unit (CBMU)*. This data consists of accurate measures of the channel bore diameter and tilt angles; this information is used to provide an overall assessment of the health of the core.

To perform a more accurate monitoring of the core over their predicted operational life, the estimation of its state should be more frequent; on the other side it is important that the reactor is not offline frequently or for long periods. On the other hand data is also gathered during core refueling operations. Nuclear fission is used to generate heat in order to produce steam to generate electricity from a turbine and, in order to sustain a constant power output, the uranium dioxide fuel needs to be periodically replaced. This process, called reactor refueling, take place with a weekly rate. An important source of information during the refueling phase is the fuel grab load trace data, that consists in collecting information on the position of the uranium bar inserted in the core and information on the force produced by the inter-

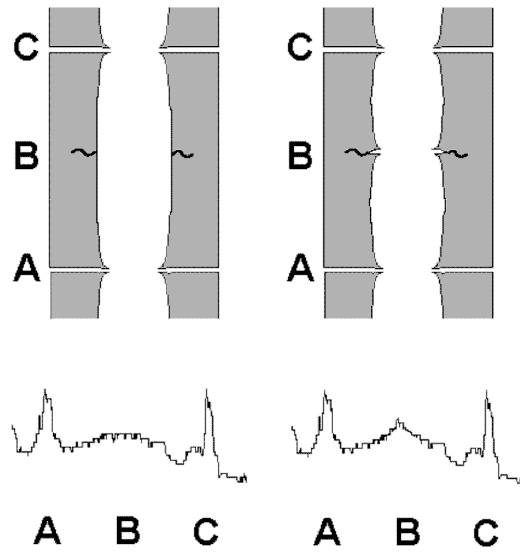

Fig. 2. The upper two diagram show a cut-away of a graphite brick with points A and C illustrating the interface between two bricks. The lower two diagrams show the load force applied on brushes.

action between the wall of the fuel channel and the fuel assembly supporting brushes. Although not originally intended for core condition monitoring purposes, the fuel grab load trace data contains a contribution from frictional interface between the fueling channel wall and the fuel assembly. Since interfaces between adjacent brick layers result in changes in the bore diameter of the channel, as the brushes supporting the fuel rods pass through these features, there is an equivalent change in the friction forces between the walls and the brushes, which correspond to an apparent change of the load force on the fuel assembly. This change in load manifest itself as peaks within the refueling load trace. Figure 2 shows traces of data recorded during a refueling operation. The reader can observe how peaks in the applied force correspond to brick layer interfaces (points A and C); moreover damages over the graphite bricks (e.g. point B) reflect on smaller peaks in the force applied on brushes (see also [1], [2] and [3]).

In [4], CBMU data was compared with load trace data coming from different refueling event and it has been shown how a load trace and a CMBU trace can furnish the same information: as depicted in figure 3 it is possible to recover from the grab force data information on the friction force applied between the supporting brushes and the fuel assembly, which can be used to monitor possible cracks of graphite bricks and hence the health of the nuclear core.

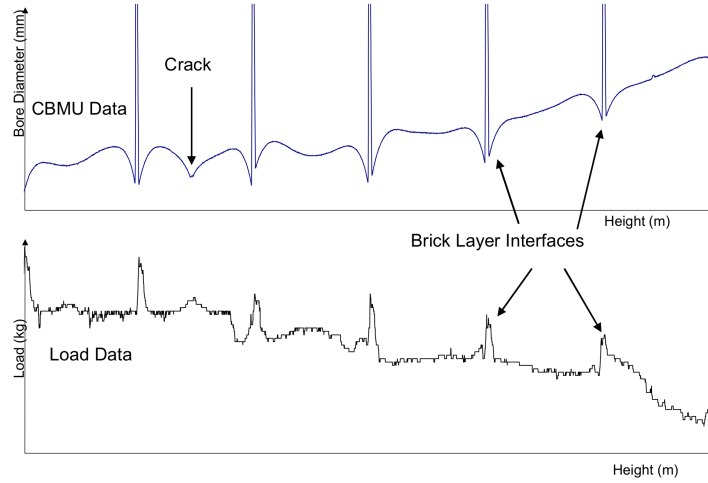

Fig. 3. Comparison of a channel bore monitoring unit trace of channel bore diameter and a refuelling load trace from the same channel.

The purpose of this work is to present a monitoring system based on analytical redundancy and directional residual generation using measurements obtained during the refueling process. In short this problem consists of building an unknown input observer with the role to estimate the friction force produced by the interaction between the wall of the fuel channel and the fuel assembly supporting brushes. This let to estimate the shape of the graphite bricks that comprise the core and, therefore, monitor any distortion of them.

The theoretical machinery exploited in this work is the Kalman filter theory (e.g. [5],[6]), which is used to estimate the information above mentioned. In a different nuclear context, in particular in safeguards problems, a similar approach has been used in [7]. In this paper we will discuss the model of the system used for estimation purposes and the application of a discrete-time Kalman filter to estimate the friction force from the fuel grab load signal stored during the refueling process. Since the initial condition of the system are not known, and considering the fact that the estimation process is performed off-line, a smoothing algorithm based on Kalman filter is introduced to improve the estimate. This is important as a matter of fact that, even if the grab load data is a time signal, as shown in figure 3, it should be considered as parametrized in the height dimension of the fueling channel wall. Hence a perfect estimate both for $t = 0$ and $t = N$ is necessary.

Moreover it will be presented how to deal with the quantization of the filtered data that introduce a noise in data streams (see e.g. [8], [9]). Finally some experimental results will be presented.

More details about this approach, can be found in [10].

2 Refueling model

Each refueling phase provides two data traces, one obtained by lowering the fueling assembly into the nuclear core, and the other one by raising the fuel assembly out from there. The fuel grab load trace data is obtained during the refueling by load cells positioned on the refueling machine which directly measure the force applied by the fuel assembly. This force depends on several factors, among which the most significant are in the following described

- a) *The weight of the fuel assembly:* this term depends on the fuel rod mass which changes due to the nuclear reactions in the core. During the extraction process it can be determined once the fuel assembly is out of the reactor.
- b) *The frictional forces:* is the quantity that we want to estimate, is caused by the interaction with the stabilizing brushes on the fuel channel wall. These brushes are set directly on the wall and the magnitude of the frictional component depends on the shape of the wall: any distortion in the channel geometry will reflect in friction force changes.
- c) *The buoyancy force:* is caused by the gas that, circulating in the fuel chamber, makes the fuel assembly appear lighter. This force is unknown and changes its effect on the fuel assembly with the position of the uranium bar into the channel. But keeping under consideration only a small part of the fuel channel, as a brick, the effect of the buoyancy force can be taken into account as an additive noise.

During refueling process, the fuel assembly is governed by the interaction of forces that simultaneously act on the fuel assembly:

$$m\mathbf{a} = \sum \mathbf{F} ; \tag{1}$$

where m is the fuel assembly mass and \mathbf{a} is its acceleration.

The forces acting on the fuel assembly are, together with the grab load force F_l applied by the supporting brushes on the assembly, its weight mg (where g is the gravitational acceleration), the brushes friction forces F_f and the aerodynamic force F_a due to the gas flow in the fuel chamber:

$$m\mathbf{a} = \mathbf{F}_l + m\mathbf{g} + \mathbf{F}_a + \mathbf{F}_f . \tag{2}$$

Rewriting equation (2) expliciting the velocity and the acceleration of the assembly, we obtain:

$$\begin{aligned} \begin{bmatrix} \dot{x}_1 \\ \dot{x}_2 \end{bmatrix} &= \begin{bmatrix} 0 & 0 \\ 1 & 0 \end{bmatrix} \begin{bmatrix} x_1 \\ x_2 \end{bmatrix} + \begin{bmatrix} 1/m \\ 0 \end{bmatrix} F_f + \begin{bmatrix} -F_l/m - g \\ 0 \end{bmatrix} + w \\ y &= \begin{bmatrix} 0 & 0 \\ 1 & 0 \end{bmatrix} \begin{bmatrix} x_1 \\ x_2 \end{bmatrix} + v , \end{aligned} \tag{3}$$

where x_1 is the position of the fuel assembly, x_2 is its speed, w is system noise and v is measurements noise. The sign of the friction force is positive

because we consider just the reactor discharge, where the friction opposes the movement of the assembly, and therefore narrowing of the channel will result in an increase in a apparent load of the fuel assembly.

In order to rewrite equation (3) in a machine-computable form, we consider its discrete-time approximation, calculating the derivatives of the position and velocity as:

$$\begin{aligned}\dot{x}_1 &= \frac{x_1(t+1) - x_1(t)}{\Delta t} \\ \dot{x}_2 &= \frac{x_2(t+1) - x_2(t)}{\Delta t},\end{aligned}\tag{4}$$

where t is discrete time and Δt is the sample period. This approximation leads to the following discrete time model of the system:

$$\begin{aligned}\begin{bmatrix} x_1(t+1) \\ x_2(t+1) \end{bmatrix} &= \begin{bmatrix} 1 & 0 \\ \Delta t & 1 \end{bmatrix} \begin{bmatrix} x_1(t) \\ x_2(t) \end{bmatrix} + \Delta t \begin{bmatrix} -1/m \\ 0 \end{bmatrix} F_f(t) + \Delta t \begin{bmatrix} -F_l/m - g \\ 0 \end{bmatrix} + w(t) \\ y(t) &= \begin{bmatrix} 1 & 0 \\ 0 & 1 \end{bmatrix} \begin{bmatrix} x_1(t) \\ x_2(t) \end{bmatrix} + v(t).\end{aligned}\tag{5}$$

In the following sections it will be presented the use of a discrete-time Kalman filter on system (5) to estimate of the amplitude of friction force F_f .

3 Using Kalman filter and smoother to estimate the core condition

Aim of this section is to present an estimation procedure that, starting from model (5) and having available the set of measures described in Section 1 (i.e. the position of the fuel assembly along the channel and the grab force applied on it), is able to estimate the friction force F_f . In order to estimate the friction force F_f applied along the fueling channel wall, we will first consider it as an unknown input for system (5) and, using an adapted version of Kalman filter for systems with unknown inputs (see [11]), we will estimate the system state. Having the state estimation it is possible to evaluate the friction force term F_f using the first equation in (5). In order to improve the estimation for small time instants (i.e. for the initial position of the fuel assembly), having a first estimation of the unknown input F_f , it is possible to use a Kalman smoother (see Appendix A) to process the system in the reverse way, find an estimation of the state and, consequently, of the friction force at time $t = N; N-1; \dots; 1; 0$. Finally, in order to find an optimal estimation of the system state, and hence an optimal estimation of the friction force, the system will be processed using a forward known input Kalman filter. Roughly speaking running the Kalman filter forward in time we estimate the state of the system, while running it backward in time we make a correction of the previous estimate of the friction

force thanks to additional information of the system gathered during the first forward estimation.

Recalling system (5), our aim is to write it in the form

$$\begin{aligned} \begin{bmatrix} z_d(t+1) \\ z_f(t+1) \end{bmatrix} &= \begin{bmatrix} F_1 & F_2 \\ F_3 & F_4 \end{bmatrix} \begin{bmatrix} z_d(t) \\ z_f(t) \end{bmatrix} + \begin{bmatrix} \bar{D} \\ 0 \end{bmatrix} d(t) + \begin{bmatrix} \bar{G}_1 \\ \bar{G}_2 \end{bmatrix} + w \\ y(t) &= [\bar{C}_1 \ \bar{C}_2] \begin{bmatrix} z_d(t) \\ z_f(t) \end{bmatrix} + v(t). \end{aligned} \quad (6)$$

where the disturbance $d(t)$ acts as the friction force F_f . Defining the non-singular real matrix U

$$U = \begin{bmatrix} 1 & -1 \\ 0 & 1 \end{bmatrix}, \quad (7)$$

it is possible to find the relation between system (5) and (6):

$$\begin{bmatrix} F_1 & F_2 \\ F_3 & F_4 \end{bmatrix} = U \begin{bmatrix} 1 & 0 \\ \Delta t & 1 \end{bmatrix} U^{-1} := \bar{A} \quad (8)$$

$$\begin{bmatrix} \bar{D} \\ 0 \end{bmatrix} = U \begin{bmatrix} -\Delta t/m \\ 0 \end{bmatrix} := \bar{B} \quad (9)$$

$$[\bar{C}_1 \ \bar{C}_2] = \begin{bmatrix} 1 & 0 \\ 0 & 1 \end{bmatrix} U^{-1} := \bar{C} \quad (10)$$

$$\begin{bmatrix} z_d(t) \\ z_f(t) \end{bmatrix} = Ux(t) := \begin{bmatrix} \bar{x}_1(t) \\ \bar{x}_2(t) \end{bmatrix}. \quad (11)$$

Note that the term

$$\Delta t \begin{bmatrix} -F_l/m - g \\ 0 \end{bmatrix} \quad (12)$$

in first equation of system (5) is not present in the correspondent equation of system (6); this matrix, referred as E , will be consider as a known input of the system (5). Following this reasoning, the system can be rewritten in the form

$$\begin{aligned} \begin{bmatrix} \bar{x}_1(t+1) \\ \bar{x}_2(t+1) \end{bmatrix} &= \bar{A} \begin{bmatrix} \bar{x}_1(t+1) \\ \bar{x}_2(t+1) \end{bmatrix} + \bar{B}F_f(t) + \bar{E} + w \\ y(t) &= \bar{C} \begin{bmatrix} \bar{x}_1(t+1) \\ \bar{x}_2(t+1) \end{bmatrix} + v(t). \end{aligned} \quad (13)$$

where

$$\bar{E} = UE = \Delta t \begin{bmatrix} -F_l - g \\ 0 \end{bmatrix} \quad (14)$$

In order to estimate the system state in presence of an unknown input, its effect on the system must be isolated; to this aim it is possible to define a non-singular real matrix V , such that

$$\begin{aligned}
Vy(t) &:= \begin{bmatrix} \bar{y}_1(t) \\ \bar{y}_2(t) \end{bmatrix} = \bar{y}(t) \\
V\bar{C} &= \begin{bmatrix} \bar{C}_{11} & \bar{C}_{12} \\ 0 & \bar{C}_{22} \end{bmatrix} \\
Vv(t) &= \begin{bmatrix} \bar{v}_1(t) \\ \bar{v}_2(t) \end{bmatrix}
\end{aligned} \tag{15}$$

in this way we have transformed the second equation of (13) in the following form:

$$\begin{aligned}
\bar{y}_1(t) &= \bar{C}_{11}\bar{x}_1(t) + \bar{C}_{12}\bar{x}_2(t) + \bar{v}_1(t) \\
\bar{y}_2(t) &= \bar{C}_{22}\bar{x}_2(t) + \bar{v}_2(t);
\end{aligned} \tag{16}$$

where \bar{C}_{11} is a matrix with rank l in order to preserve system observability.

Now it is possible to rewrite the first equation in (16) as

$$\bar{x}_1(t) = \bar{C}_{11}^{-1} [\bar{y}_1(t) - \bar{C}_{12}\bar{x}_2(t) - \bar{v}_1(t)] \tag{17}$$

and substituting this into the first equation of (13) it is possible to find that

$$\begin{aligned}
\bar{x}_2(t+1) &= \tilde{A}\bar{x}_2(t) + \tilde{B}\bar{y}_1(t) + \tilde{E}_2 + \tilde{G}\tilde{w}(t) \\
\bar{y}_2(t) &= \bar{C}_{22}\bar{x}_2(t) + \bar{v}_2(t),
\end{aligned} \tag{18}$$

where

$$\begin{aligned}
\tilde{A} &= [\bar{A}_{22} - \bar{A}_{21}\bar{C}_{11}^{-1}\bar{C}_{12}] \\
\tilde{B} &= \bar{A}_{21}\bar{C}_{11}^{-1} \\
\tilde{G} &= [\bar{G}_2 - \bar{A}_{21}\bar{C}_{11}^{-1}] \\
\tilde{w}(t) &= [w(t) \ \bar{v}_1(t)]^T.
\end{aligned} \tag{19}$$

Now system (18) is exactly the same as (89) in Appendix A, hence we can find the estimate of the state applying the known input Kalman filter according to the following procedure.

First iteration: unknown input Kalman Filter

State estimation a priori:

$$\hat{x}_2(t+1) = \tilde{A}\hat{x}_2(t|t) + \tilde{B}\hat{y}_1(t) \tag{20}$$

Error covariance a priori:

$$P_2(t+1) = \tilde{A}P_2(t|t)\tilde{A}^T + Q_2 \tag{21}$$

Kalman gain matrix:

$$K(t+1) = P_2(t+1)\bar{C}_{22}^T [\bar{C}_{22}P_2(t+1)\bar{C}_{22}^T + R_2]^{-1} \tag{22}$$

State estimation a posteriori:

$$\hat{x}_2(t+1|t+1) = \hat{x}_2(t+1) + K(t+1) [\bar{y}_2(t+1) - \bar{C}_{22}\hat{x}_2(t+1)] \quad (23)$$

Error covariance a posteriori:

$$\begin{aligned} P_2(t+1|t+1) &= P_2(t+1) - P_2(t+1)\bar{C}_{22}^T [\bar{C}_{22}P_2(t+1)\bar{C}_{22}^T + R_2]^{-1} \\ &\quad \bar{C}_{22}P_2(t+1) \\ &= P_2(t+1) - K(t+1)\bar{C}_{22}P_2(t+1) \end{aligned} \quad (24)$$

Initial conditions

$$\hat{x}_2(0) = 0 \quad P_2(0) = 1e7. \quad (25)$$

Having the estimate $\hat{x}_2(t)$ it is possible to compute $\hat{x}_1(t)$ from equation (17) as

$$\hat{x}_1(t) = \bar{C}_{11}^{-1} [\bar{y}_1(t) - \bar{C}_{12}\hat{x}_2(t|t)] \quad (26)$$

with conditional covariance

$$P_1(t) = \bar{C}_{11}^{-1}\bar{C}_{12}P_2(t|t)\bar{C}_{12}^T\bar{C}_{11}^{-1} + \bar{C}_{11}^{-1}R_1(t)\bar{C}_{11}^{-1}, \quad (27)$$

where $R_1(t)$ is the covariance matrix of the noise term $v_1(t)$.

From the estimates $\hat{x}_1(t)$ and $\hat{x}_2(t)$ it is possible to compute the friction force $F_f(t)$ using the first equation of (13):

$$\hat{F}_f(t) = \bar{B}^{-1} [\hat{x}_1(t+1) - \bar{A}_{11}\hat{x}_1(t) - \bar{A}_{12}\hat{x}_2(t|t) - \bar{E}_1]. \quad (28)$$

Moreover the estimate state $x(t)$ of system (5) and its error covariant matrix can be computed as:

$$\begin{aligned} \hat{x}(t) &= U^{-1} \begin{bmatrix} \hat{x}_1(t) \\ \hat{x}_2(t) \end{bmatrix} \\ P(t) &= U^{-1} \begin{bmatrix} P_1(t|t) & L(t) \\ L^T(t) & P_2(t|t) \end{bmatrix} \end{aligned} \quad (29)$$

where

$$L(t) = -\bar{C}_{11}^{-1}\bar{C}_{12}P_2(t|t). \quad (30)$$

The Kalman filter based algorithm just presented is able to estimate the state of the system even if a disturbance (represented in our case by the friction force determined by the brushes) is acting on it. From this estimate it is possible to compute the magnitude of the friction force F_f simply using (13). It is important to note that the statistic property of the friction force at the instant time $t = 0$ are not known, and therefore the state estimation in $t = 0$ is not appropriate. Remember that this fact reflects in a wrong estimation of the friction force applied on the fuel assembly around its initial position.

The idea to deal with this problem is to use the estimation of the friction force to improve the state estimates just by gathering information in the reverse way. Thus, applying the backward Kalman filter on system (5), here rewritten as

$$\begin{aligned}\bar{x}(t+1) &= A\bar{x}(t) + BF_f(t) + E(t) + w(t) \\ y(t) &= C\bar{x}(t) + v(t) ;\end{aligned}\quad (31)$$

it is possible to obtain the optimal estimate of the friction force at time $t = 0$. The backward Markovian model considering now the friction force as a known input is

$$\begin{aligned}\bar{x}_b(t) &= A^{-1}\bar{x}_b(t+1) - A^{-1}B\hat{F}_f(t) - \bar{A}^{-1}E(t) + w(t) \\ y(t) &= C\bar{x}_b(t) + v(t) ;\end{aligned}\quad (32)$$

applying the Kalman smoothing algorithm to system (32) it is possible to estimate its state from $t = N$ up to $t = 0$ using the following procedure.

Second iteration: known input Kalman Smoother

State estimation a priori:

$$\hat{x}_b(t-1|t) = A^{-1}\hat{x}_b(t|t) - A^{-1}BF_f(t-1) - A^{-1}E(t) \quad (33)$$

Error covariance a priori:

$$P_b(t-1) = A^{-1}P_b(t|t)A^{-1T} + A^{-1}Q(t)A^{-1T} \quad (34)$$

Kalman gain matrix:

$$K_b(t-1) = P_b(t-1)C^T [CP_b(t-1)C^T + R(t-1)]^{-1} \quad (35)$$

State estimation a posteriori:

$$\hat{x}_b(t-1|t-1) = \hat{x}_b(t-1) + K_b(t-1)[y(t-1) - C\hat{x}_b(t-1)] \quad (36)$$

Error covariance a posteriori:

$$P_b(t-1|t-1) = P_b(t-1) - K_b(t-1)CP_b(t-1) \quad (37)$$

Initial conditions:

$$\hat{x}_b(N) = \hat{x}(N|N) \quad P_b(N) = P(N|N) \quad (38)$$

Applying this algorithm, a new state estimate for $t = N$ through $t = 0$ has been computed, and, consequently, the estimate of the friction force from time $t = N$ up to $t = 0$ has been obtained using the second equation of (31).

Running forward in time and backward in time the Kalman filter algorithm, we have obtained an estimate of the static property of the disturbance that acts on the system, which was not known; with this additional information, it is possible to estimate the state of the system in a proper way using a standard forward in time Kalman filter for systems with known inputs.

Third iteration: known input Kalman Filter

State estimation a priori:

$$\hat{x}(t+1) = A\hat{x}(t|t) + BF_f(t+1) + E(t) \quad (39)$$

Error covariance a priori:

$$P(t+1) = AP(t|t)A^T + Q(t) \quad (40)$$

Kalman gain matrix:

$$K(t+1) = P(t+1)C^T [CP(t+1)C^T + R(t+1)]^{-1} \quad (41)$$

State estimation a posteriori:

$$\hat{x}(t+1|t+1) = \hat{x}(t+1) + K(t+1)[y(t+1) - C\hat{x}(t+1)] \quad (42)$$

Error covariance a posteriori:

$$P(t+1|t+1) = P(t+1) - K(t+1)CP(t+1) \quad (43)$$

Initial conditions:

$$\hat{x}(0) = \hat{x}_b(0) \quad P(0) = P_b(0) \quad (44)$$

Finally the estimation of the friction force can be computed as

$$\hat{F}_f(t) = B^{-1} [\hat{x}(t+1) - A\hat{x}(t) - E(t)] . \quad (45)$$

4 Simulation results of the proposed estimation scheme

The three steps algorithm just explained has been applied to real data stored during refueling operations. In figure 4 and 5 measurements of the grab force F_l and of the fuel assembly position x_2 gathered during the refueling process are shown.

In figure 6 and figure 7 is depicted the estimation of the friction force after the first step of the algorithm, i.e. after having applied the unknown input Kalman filter. It is possible to observe that the estimated friction force has the same trend of the grab force, but its shape is not exactly the same. This

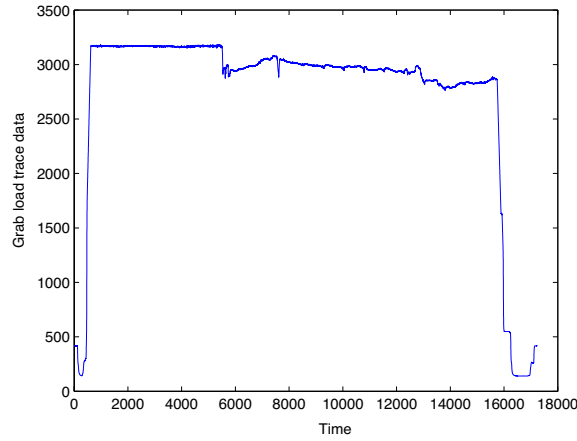

Fig. 4. Grab load trace data gathered during refueling.

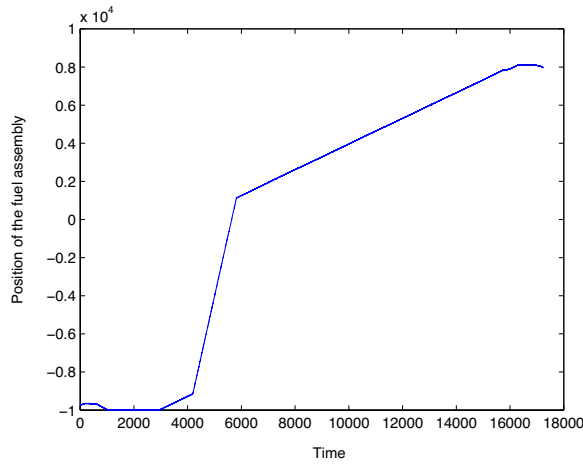

Fig. 5. Position of the fuel assembly during refueling.

is due to the fact that statistic property of the disturbance F_f are not known for $t = 0$.

In figure 8 and figure 9 is presented the estimation of the friction force after having applied the Kalman smoothing algorithm. The result obtained is absolutely better (figure 7).

Remembering that the smoother algorithm has the role to propagate the estimation of the friction force from time $t = N$, to time $t = 0$, a better result can be obtained by processing the system once more by a forward Kalman filter, where now the statistic property of the friction force for $t = 0$ are known, because they are given by the combined use of the first forward Kalman filter

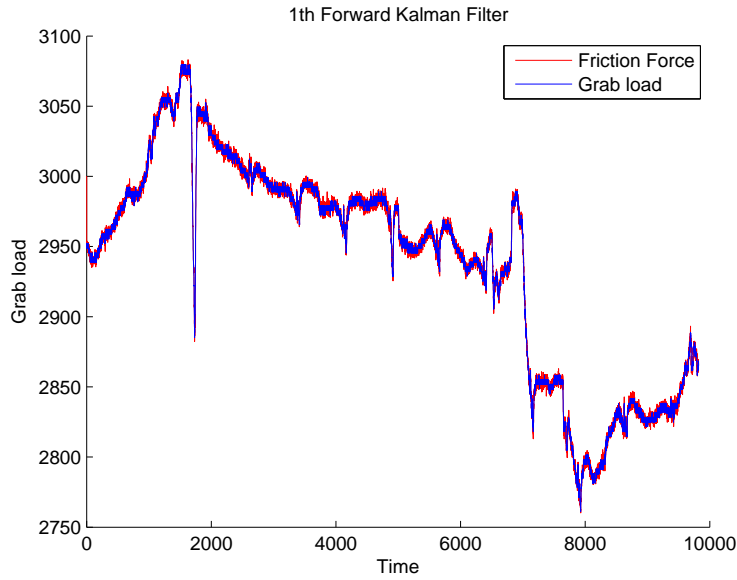

Fig. 6. First iteration estimation.

and the smoother. The results of this third step are shown in figure 10 and figure 11. In this case the trend and the shape of the estimate friction force are exactly the same as the grab load, and this demonstrates that it is possible to obtain an optimal estimation of the acting disturbance without an a priori knowledge on it.

In figure 11 it is possible to observe that still some small errors in the estimate are present; these imperfections are due to the approximate model of the system used to estimate the friction force. For example the model does not consider the noise introduced by the quantization of data, moreover both the mass m of the fuel assembly and the value of the buoyancy force F_a are approximated and considered constant.

In the following section a procedure to deal with the noise introduced by the quantization of data is presented and final simulation results are discussed.

5 Dealing with quantization

Aim of this section is to give some guidelines on how to face the problem of state estimation using quantized measurements; this is necessary since grab load data are quantized and the quantization introduces a noise that affects the estimate. In the following some necessary condition for the maximum likelihood estimate (see [12]) when the observations have been quantized will be given and a Quantization Regression (QR) algorithm (still based on Kalman

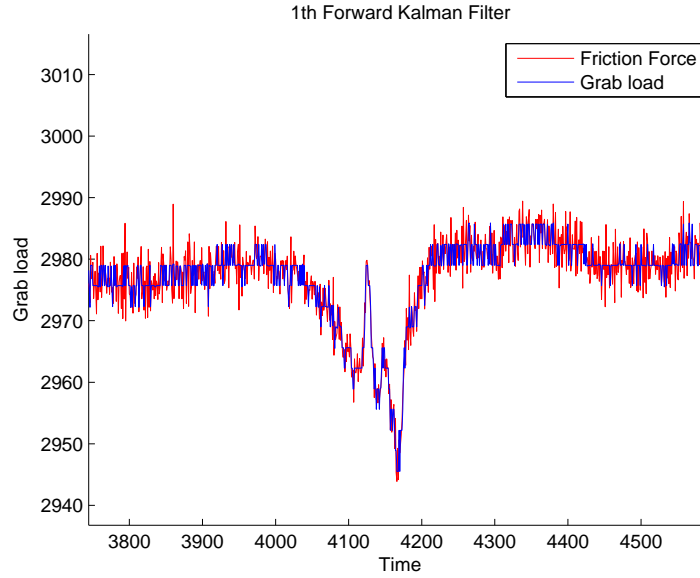

Fig. 7. First iteration estimation (zoom in).

filter) which generates an estimate of an autoregressive time series from quantized measurements will be described.

As reported in [13], the effect of a uniform quantization can be modeled as an additive noise that is uniformly distributed, uncorelated with the input signal, and has white spectrum. Consider the following model with quantized measurements:

$$\begin{aligned} x_{t+1} &= f(x_t, w_t) \\ z_t &= h(x_t) + e_t \\ y_t &= Q_m(z_t) \end{aligned} \quad (46)$$

where $Q_m(\cdot)$ is the quantization function. The problem of optimally estimate the state of (46) is a problem of nonlinear non-Gaussian filtering; as explained in [5] such a problem has a Bayesian solution given by

$$\begin{aligned} p(x_{t+1} | Y_t) &= \int_{R^n} p(x_{t+1} | x_t) dx_t \\ p(x_t | Y_t) &= \frac{p(y_t | x_t) p(x_t | Y_{t-1})}{p(y_t | Y_{t-1})}. \end{aligned}$$

This problem is in general not analytically solvable, but there exists two different approach to deal with it:

- a) use an *extended Kalman filter* (EKF) that is a sub-optimal filter for an approximate linear Gaussian model designed using the assumption that the quantization introduce an additive uniform noise;

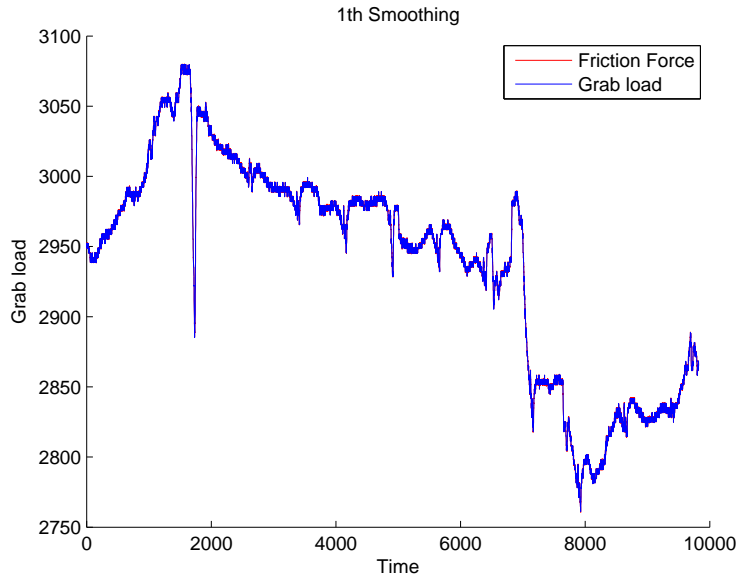

Fig. 8. Second iteration estimation.

- b) use a numerical approach to find a maximum-likelihood estimates of parameters, approximating in this way the optimal solution to the Bayesian filtering problem.

Regarding the first approach, it can be easily introduced considering the following linear Gaussian model with quantized observations:

$$\begin{aligned}
 x_{t+1} &= F_t x_t + G_t w_t & \text{Cov}(w_t) &= Q_t \\
 z_t &= H_t x_t + e_t & \text{Var}(e_t) &= \sigma^2 \\
 y_t &= Q_m(z_t)
 \end{aligned}
 \tag{47}$$

where y_t represents the quantized measurements. Using the assumption that the quantization introduce an additive uniform noise, the optimal filter is given by Kalman filter by increasing the measurement covariance R_t by term equal to $q^2/12$, i.e.

$$R_t = \left(\sigma_t^2 + \frac{q^2}{12} \right) I,
 \tag{48}$$

where q is the quantization box size and I is a suitably dimensioned identity matrix. From (48) it turns out that the measurements covariance matrix R_t is increased of a quantity that depends on how small the quantization box size is and hence on the variance of the quantization noise (cf. [14]). Using (48) it is therefore possible to tune the filter to obtain the best estimation for the problem.

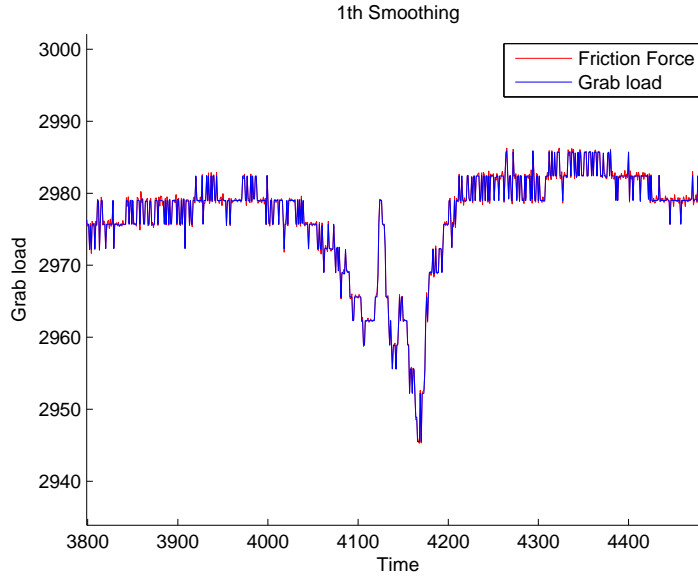

Fig. 9. Second iteration estimation (zoom in).

In the following a slightly different Kalman filter obtained by the Bayesian equation as shown in [15] will be introduced; considering this filter, necessary conditions for the maximum-likelihood estimate of parameters when the observations are quantized will be formulated.

Consider the following linear measurement equation

$$z = Hx + v \quad (49)$$

where x is the vector to be estimated, z is the measurement vector, and v is the measurement noise. Recall that, with non-quantized measurements, the maximum-likelihood estimate (cf [12]) is the value of x that maximizes the likelihood function $L(z; x)$:

$$\hat{x} = \arg[\max_x L(z, x)] = \arg[\max_x p(z : x)] , \quad (50)$$

where the notation $p(z : x)$ means the probability-density function of z with x as a parameter of the distribution.

When the measurements are quantized numerical values of z are not available and the knowledge of the measurements is reflected in the inequalities

$$\{a^i \leq z^i < b^i\} , \quad (51)$$

where a^i and b^i are the lower and upper bounds of the quantum interval in which the i -th component of z is known to lie. Considering this fact, the

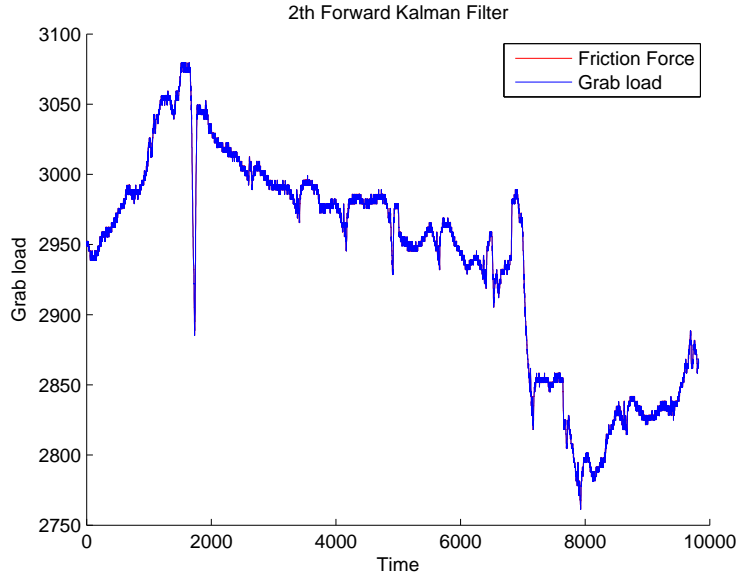

Fig. 10. Third iteration estimation.

likelihood function to be used is the probability that the measurements fall in the hypercube defined by equation (51):

$$L(a^i, b^i, x) = \prod_i P [a^i - (Hx)^i \leq v^i < b^i - (Hx)^i] . \quad (52)$$

Hence the maximum-likelihood estimate of x with quantized measurements is

$$\hat{x} = \arg \left\{ \max_x \prod_i P [a^i - (Hx)^i \leq v^i < b^i - (Hx)^i] \right\} . \quad (53)$$

Denoting with P_i the term $P [a^i - (Hx)^i \leq v^i < b^i - (Hx)^i]$, such that

$$P_i = \int_{a^i - (Hx)^i}^{b^i - (Hx)^i} p_{v^i}(u) du ,$$

the necessary condition for maximum likelihood estimate is the following:

$$\begin{aligned} \frac{1}{L(a^i, b^i, x)} \left(\frac{\partial L(a^i, b^i, x)}{\partial x} \right) &= \sum_i \frac{\partial P_i / \partial x}{P_i} = \\ &= \sum_i \frac{p_{v^i}(b^i - (Hx)^i) - p_{v^i}(a^i - (Hx)^i)}{P_i} h^i = 0 , \end{aligned} \quad (54)$$

where the row vector h^i is the i -th row of H . Hence the problem can be formulated as following. Given

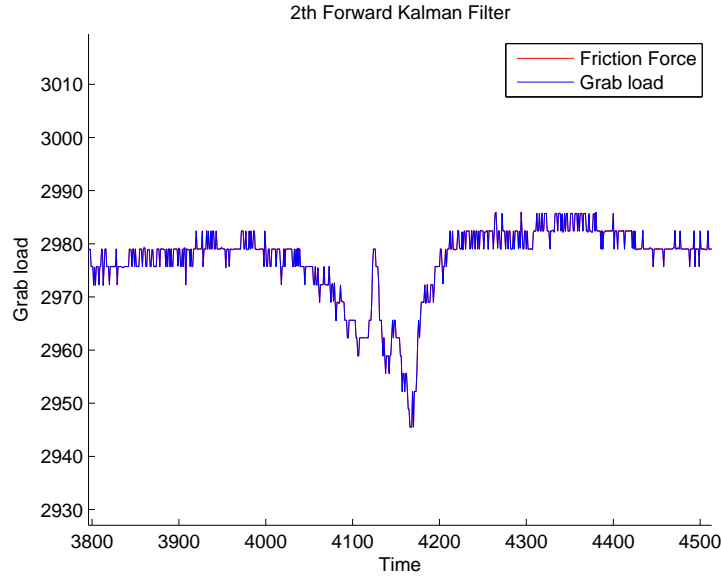

Fig. 11. Third iteration estimation (zoom in).

- i) the measurement equation $z = h(x, v)$,
- ii) the joint probability density function of parameter and noise vectors $p_{x,v}(\xi, v)$,
- iii) the constraint $z \in A$, where A is some hypercube for quantized measurements,

the estimation problem with quantized measurements consists in :

- A) finding the conditional mean of $f(x)$ given a measurement z : $E[f(x) | z]$,
- B) averaging this function of z considering the constraint $z \in A$.

Assume that the state vector and measurements variables satisfy the relationships

$$\begin{aligned}
 x_{i+1} &= \Phi_i x_i + w_i \\
 z_i &= H_i x_i + v_i \\
 E(x_0) &= \bar{x}_0 & \text{cov}(x_0) &= P_0 \\
 E(w_i) &= 0 & E(w_i w_j^T) &= Q_i \delta_{ij} \\
 E(v_i) &= 0 & E(v_i v_j^T) &= R_i \delta_{ij} \\
 E(w_i v_j^T) &= 0 & E(w_i x_0^T) &= E(v_i x_0^T) = 0
 \end{aligned} \tag{55}$$

where x_i is the system state vector at time t_i , Φ_i is the system transition matrix from time t_i to t_{i+1} , w_i is a realization of the process noise at t_i , z_i is the measurement vector at time t_i , H_i is measurements matrix at time t_i and v_i is a realization of the observation noise at time t_i . Each of the m components of the normally distributed vector z has zero mean and lies in a

interval whose limits are $\{a^i\}$ and $\{b^i\}$, $a^i \leq z^i < b^i$, ($i = 1, 2, 1 \dots, m$). Let (γ^i) ($i = 1, 2, 1 \dots, m$) be the m components of the geometric center vector γ of the region A :

$$\gamma^i = \frac{1}{2}(b^i + a^i), \quad (56)$$

and let (α^i) ($i = 1, 2, 1 \dots, m$) be the m components of the quantum interval half-widths vector α :

$$\alpha^i = \frac{1}{2}(b^i - a^i). \quad (57)$$

It is possible to show that, expanding the probability-density function in power series in an interval containing γ and neglecting terms higher than the fourth order, the mean and covariance of z conditioned on $z \in A$ are given by

$$E(z | z \in A) \approx \gamma - A\Gamma^{-1}\gamma \quad (58)$$

$$\text{cov}(z | z \in A) \approx A = \left\{ \frac{(\alpha^i)^2}{3} \delta_{ij} \right\} \quad (59)$$

where $\Gamma = E(zz^T)$ and δ_{ij} is the Kronecker delta. In this case the minimum-variance linear estimate x^* and its covariance E^* are given by

$$x^* = \bar{x} + K^*(\gamma - H\bar{x}) \quad (60)$$

$$E^* = M - MH^T(\Gamma + A)^{-1}HM \quad (61)$$

where

$$K^* = MH^T(\Gamma + A)^{-1} \quad (62)$$

$$\Gamma = \text{cov}(z) = HMM^T + R. \quad (63)$$

This problem can therefore be solved recursively with a modified Kalman filter, leading to the following result. Assuming the conditional distribution of the state just before the i -th measurements being $N(\hat{x}_{i|i-1}, M_i)$, then the Gaussian fit algorithm for a linear system with quantized system is the following:

$$\hat{x}_{i|i} = \hat{x}_{i|i-1} + K_i[E(z_i | z_i \in A_i) - H_i\hat{x}_{i|i-1}] \quad (64)$$

$$K_i = M_i H_i^T (H_i M_i H_i^T + R_i)^{-1} \quad (65)$$

$$P_i = M_i - M_i H_i^T (H_i M_i H_i^T + R_i)^{-1} H_i M_i \quad (66)$$

$$E_i = P_i + K_i \text{cov}(z_i | z_i \in A_i) K_i^T \quad (67)$$

$$\hat{x}_{i+1|i} = \Phi_i \hat{x}_{i|i} \quad (68)$$

$$M_{i+1} = \Phi_i E_i \Phi_i^T + Q_i, \quad (69)$$

where $\hat{x}_{i|i}$ is the conditional mean of x_i for quantized measurements up to and including t_i , $\hat{x}_{i|i-1}$ is the conditional mean of x_i for quantized measurements

up to and including t_{i-1} , A_i is the quantum region in which z_i falls, M_i is the conditional covariance of x_i for quantized measurements up to and including t_{i-1} , K_i is the Kalman filter gain matrix at t_i , P_i is the conditional covariance of estimate, and E_i is the conditional covariance of x_i for quantized measurements up to and including t_{i-1} .

Note that equations (64) correctly describe the propagation of the first two moments of the conditional distribution under the assumption of Gaussian noises. Let $e = x - \hat{x}$ be the estimation error, and consider the dynamic

$$e_{i+1|i} = \Phi_i e_{i|i} - w_i .$$

Since $e_{i|i}$ is not Gaussian, so $e_{i+1|i}$ is not Gaussian too, but it tends to a Gaussian distribution because of the addition of Gaussian process noise w_i and of the action performed by the state transition matrix Φ_i . Considering this, equations (64) yield a good approximation of the conditional moments.

Concluding it is important to remark that the recursive algorithm described by (64) is very similar to the algorithm describing the Kalman filter, with two important differences:

- the conditional mean of the measurements vector at t_i is used as an input for the filter;
- the conditional covariance equation is being forced by the random variable $\text{cov}(z_i | z_i \in A_i)$.

Following the theory just presented a set of simulation with the modified algorithm has been performed and the results are presented in figure 12. It is possible to see that now the estimation algorithm leads to a perfect estimate of the friction force.

6 Concluding remarks

In this work we have presented an estimation algorithm based on Kalman filter to monitor the condition of the core of AGR nuclear stations. In particular, using data stored during the core refueling phase, it is possible to estimate the friction force that the fuel rod apply on the supporting brushes which are embedded in the core wall. In this way it is possible to estimate the shape of the graphite bricks that compose the core and therefore the condition of the core itself.

Future works will consists in gathering existing and historical data in a single location and define patterns in order to determinate whether time, location, operating condition have an effect on the trace.

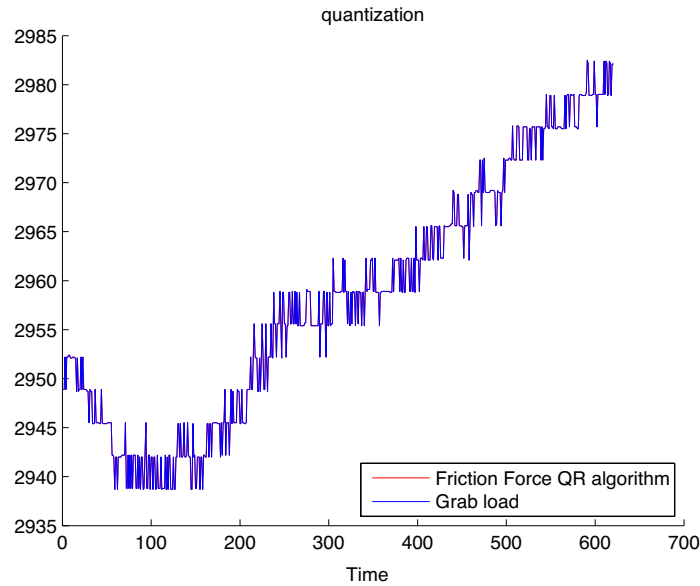

Fig. 12. Estimation of friction force using the modified Kalman filter to deal with quantization (zoom in).

Acknowledgement

Authors wish to thank British Energy Agency and in particular Dr. Jim Reed for making possible a fruitful collaboration and for the permission of using real-plant data.

References

1. Pang Y, Giovanini L, Grimble M J (2006) Condition monitoring of a advanced gas-cooled nuclear reactor core, *Internal report, British Energy*
2. Pang Y, Grimble M J, Ordys A W, Reed J (2007) Condition monitoring of the nuclear graphite core using benchmarking techniques, *Proceedings of the European Control Conference, Kos, Greece*
3. West G M, Jahn G J, McArthur D J, Reed J (2005) Graphite core condition monitoring through intelligent analysis of fuel grab load trace data, *Internal report, British Energy*
4. West G M, McArthur S D J, McDonald J R, Ballantyne A, Reed J, Beynon S (2005) Graphite core brick crack detection through automated load trace analysis, *Internal report, British Energy*
5. Jazwinski A H (1970) Stochastic processes and filtering theory, *Mathematics in science and engineering*, 64
6. Grawal M S, Andrews A P (1993) *Kalman filtering theory and practice*, Prentice Hall, Englewood Cliffs, NJ

7. Bonivento C (1983) On line state estimation and indirect measurement in safeguards systems. In: *Argentesi F, Avenhaus R, Franklin M, Shipley J P (eds) Mathematical and statistical methods in nuclear safeguards*, Harwood academic publisher, London, UK
8. Ziskand I, Hertz D (1993) *IEEE Transactions on Signal Processing*, 41:3202–3206
9. Lepschy A, Mian G A, Viaro U (1988) *IEEE Transactions on circuits and systems*, 35:461–466
10. Monari M (2007) Studio di una tecnica di monitoraggio dello stato della camera di combustione di reattori nucleari AGR, Master Thesis, University of Bologna, ITALY
11. Emara-Shabaik H (2003) *Journal of dynamic systems, measurements and control*, 29:482–485
12. Raunch H E, Tung F, Striebel C T (1965) Maximum likelihood estimates of linear dynamical systems, *AIAA Journal*, 3(8)
13. Widrow B, Kollar I, Liu M C (1996) *IEEE Transactions on Instrumentation and Measurements*, 45:482–485
14. Wang M, Thornhill N F, Huangh B (2001) Time series reconstruction from quantized measurements, *Proceedings of the CPCE conference*, Tucson, AZ
15. Curry R (1970) *Estimation and control with quantized measurements*, The MIT Press, Boston, MA

A Kalman filtering, prediction and smoothing

In order to collect symbols and definitions used along the paper, in this Appendix the main formulas of the celebrated Kalman machinery for filtering, prediction and smoothing are briefly reported.

Consider a stochastic system represented by the following model:

$$x_k = \phi_{k-1}x_{k-1} + w_{k-1} \quad (70)$$

$$y_k = H_k x_k + v_k . \quad (71)$$

Let $x \in R^n$ (state of the system) and $y \in R^l$ (measurements) be jointly Gaussian random vectors with mean vectors $\mu_x = E\{x\}$ and $\mu_y = E\{y\}$ respectively, and covariance matrixes

$$\Sigma = \begin{bmatrix} \Sigma_{xx} & \Sigma_{xy} \\ \Sigma_{yx} & \Sigma_{yy} \end{bmatrix} := \begin{bmatrix} \text{cov}\{x, x\} & \text{cov}\{x, y\} \\ \text{cov}\{y, x\} & \text{cov}\{y, y\} \end{bmatrix} . \quad (72)$$

Assume the covariance matrix $\Sigma \in R^{(n+l) \times (n+l)}$ to be positive definite. The measurement and plant noises v_k and w_k are assumed to be zero-mean Gaussian sequences, while the initial value x_0 is considered a Gaussian variate with known mean x_0 and known covariance matrix P_0 . According to the previous definitions, the following statements hold:

$$\begin{aligned}
 E \langle w_k \rangle &= 0 \\
 E \langle w_k w_i^T \rangle &= \Delta(k-i)Q_k \\
 E \langle v_k \rangle &= 0 \\
 E \langle v_k v_i^T \rangle &= \Delta(k-i)R_k
 \end{aligned} \tag{73}$$

where $\Delta(k-i)$ stands for the *Kronecker delta function*, and the noise sequences w_k and v_k are assumed to be uncorrelated.

The problem of optimal estimation is to find the minimum variance estimate $\hat{x}(t+m|t)$ of the state vector $x(t+m)$ based on the observations up to time t of the system (70). This means designing a filter that produce the estimate $\hat{x}(t+m|t)$ minimizing the performance index

$$J = E \left\{ |x(t+m) - \hat{x}(t+m|t)|^2 \right\} \tag{74}$$

We will refer to this problem as *prediction* if $m > 0$, *filtering* if $m = 0$ and *smoothing* if $m < 0$.

Define the estimation error $\tilde{x}(t+m|t)$ as the difference between the real state value $x(t+m)$ and the estimate $\hat{x}(t+m|t)$:

$$\tilde{x}(t+m|t) = x(t+m) - \hat{x}(t+m|t) \tag{75}$$

and let the error covariance matrix be

$$P(t+m|t) := E \{ [x(t+m) - \hat{x}(t+m|t)][x(t+m) - \hat{x}(t+m|t)]^T \} . \tag{76}$$

Denoting with \mathcal{Y}_t the linear space generated by the observations, the minimum variance estimation $\hat{x}(t+m|t)$ is given by the orthogonal projection of $x(t+m)$ onto \mathcal{Y}_t

$$\hat{x}(t+m|t) = \hat{E} \{ x(t+m) | \mathcal{Y}_t \} , \tag{77}$$

i.e. the optimality of $\hat{x}(t+m|t)$ is obtained when the estimation error $\tilde{x}(t+m|t)$ is orthogonal to the data space:

$$\tilde{x}(t+m|t) = x(t+m) - \hat{x}(t+m|t) \perp \mathcal{Y}_t ; \tag{78}$$

moreover this estimate is unbiased, which means that

$$E \{ \tilde{x}(t+m|t) \} = 0 \quad \text{for } t = 0, 1, \dots \tag{79}$$

Consider now a multivariable Gaussian Markov discrete-time linear system

$$\begin{aligned}
 x(t+1) &= A(t)x(t) + w(t) \\
 y(t) &= C(t)x(t) + v(t)
 \end{aligned} \tag{80}$$

where $x \in \mathbb{R}^n$ is the state vector, $y \in \mathbb{R}^p$ is the observation vector, $w \in \mathbb{R}^n$ is the plant noise vector, and $v \in \mathbb{R}^p$ is the observation noise vector. Let

$A(t) \in \mathbb{R}^{n \times n}$, $C(t) \in \mathbb{R}^{p \times n}$ be deterministic function of the time t and $w(t)$ and $v(t)$ zero mean Gaussian white noise vectors with covariance matrixes

$$E \left\{ \begin{bmatrix} w(t) \\ v(t) \end{bmatrix} [w(t)^T v(t)^T] \right\} = \begin{bmatrix} Q(t) & S(t) \\ S^T(t) & R(t) \end{bmatrix} \quad (81)$$

where $Q(t) \in \mathbb{R}^{n \times n}$ is nonnegative defined, and $R(t) \in \mathbb{R}^{p \times p}$ is positive defined for all $t = 0, 1, \dots$. The initial state $x(0)$ is Gaussian with mean $E\{x(0)\} = \mu_x(0)$ and covariance matrix

$$E \left\{ [x(0) - \mu_x(0)] [x(0) - \mu_x(0)]^T \right\} = \Pi(0); \quad (82)$$

moreover $x(0)$ is uncorrelated with the noise $w(t)$, $v(t)$, $t = 0, 1, \dots$. By using orthogonal projection operators, it is possible to define the following algorithm for the one step ahead Kalman predictor.

State estimation a priori:

$$\hat{x}(t+1) = A(t+1)\hat{x}(t|t) \quad (83)$$

Error covariance a priori:

$$P(t+1) = A(t)P(t|t)A^T(t) + Q(t) \quad (84)$$

Kalman gain matrix:

$$K(t+1) = P(t+1)C^T(t+1) [C(t+1)P(t+1)C^T(t+1) + R(t+1)]^{-1} \quad (85)$$

State estimation a posteriori:

$$\hat{x}(t+1|t+1) = \hat{x}(t+1) + K(t+1) [y(t+1) - C(t+1)\hat{x}(t+1)] \quad (86)$$

Error covariance a posterior:

$$P(t+1|t+1) = P(t+1) - K(t+1)C(t+1)P(t+1) \quad (87)$$

Initial condition:

$$\hat{x}(0) = \mu_x(0) \quad P(0) = \Pi(0) \quad (88)$$

Consider now a discrete-time stochastic linear system with forcing input

$$x(t+1) = A(t)x(t) + B(t)u(t) + w(t) \quad (89)$$

$$y(t) = C(t)x(t) + v(t) \quad (90)$$

where $u(t) \in \mathbb{R}^m$ is the input vector, and $B(t) \in \mathbb{R}^{n \times m}$ is input distribution matrix. We assume that $u(t)$ is measurable in the sense that $u(t)$ is a function of the outputs.

Exploiting the linearity of the system it is possible to decompose state trajectories in two terms: the free-response $x_w(t)$ and the forced-response $x_u(t)$:

$$x_w(t + 1) = A(t)x_w(t) + w(t), \quad x_w(0) = x(0) \quad (91)$$

$$x_u(t + 1) = A(t)x_u(t) + B(t)u(t), \quad x_u(0) = 0 ; \quad (92)$$

the solution $x(t + 1)$ of (89) is expressed by the superimposition of the effects:

$$x(t + 1) = x_w(t + 1) + x_u(t + 1), \quad t = 0, 1, \dots .$$

The forced term $x_u(t)$ is known since $u(t)$ is measurable and, defining the state transition matrix $\Phi(t, s)$, it can be computed as

$$x_u(t) = \sum_{k=0}^{t-1} \Phi(t, k + 1)B(k)u(k), \quad t = 0, 1, \dots \quad (93)$$

Since $x_u(t)$ is known, the algorithm should compute the estimates of the vector $x_w(t)$ based on the observations and defining the measurements

$$\ell(t) = y(t) - C(t)x_u(t) = C(t)x_w(t) + v(t) . \quad (94)$$

Since the system

$$x_w(t + 1) = A(t)x_w(t) + w(t) \quad (95)$$

$$\ell(t) = C(t)x_w(t) + v(t) \quad (96)$$

it is completely equivalent to the stochastic system of (80), it is possible to write the Kalman filter algorithm for the stochastic linear dynamic system as previously described, but using the following a priori state estimation equation:

$$\hat{x}(t + 1) = A(t + 1)\hat{x}(t | t) + B(t + 1)u(t + 1) \quad (97)$$

A *smoother* estimates the state of a system at time t using measurements made before and after time t . The accuracy of a smoother is generally better the one obtained by a forward filter, because it use more measurements for its estimate. So the optimum linear smoothing provides an estimate of the past value of the desired quantities. It is possible to represent the problem using a backward Markovian model and therefore to solve the problem using a Kalman filter designed for the backward Markovian model. This filter is called backward Kalman filter and is defined by the following algorithm.

State estimation a priori:

$$\hat{x}_s(t - 1 | t) = A^{-1}(t)\hat{x}_s(t | t) - A^{-1}D(t - 1)u(t - 1) \quad (98)$$

Error covariance a priori:

$$P_s(t - 1) = A^{-1}(t)P_s(t | t)A^{-1}(t) + A^{-1}(t)Q(t)A^{-1}(t) \quad (99)$$

Kalman gain matrix:

$$K_s(t-1) = P_s(t-1)C^T(t-1) [C(t-1)P_s(t-1)C^T(t-1) + R(t-1)]^{-1} \quad (100)$$

State estimation a posteriori:

$$\hat{x}_s(t-1 | t-1) = \hat{x}_s(t-1) + K_s(t-1) [y(t-1) - C(t-1)\hat{x}_s(t-1)] \quad (101)$$

Error covariance a posteriori:

$$P_s(t-1 | t-1) = P_s(t-1) - K_s(t-1)C(t-1)P_s(t-1) \quad (102)$$

Initial condition:

$$\hat{x}_s(N) = \hat{x}(N | N) \quad P_s(N) = P(N | N) \quad (103)$$