



Strathprints Institutional Repository

Emhemed, Abdullah Swissi and Crolla, Paul and Burt, Graeme (2011) *Using real-time simulation to assess the impact of a high penetration of LV connected microgeneration on the wider system performance during severe low frequency*. In: *iecon*, 2011-11-07 - 2011-11-10, Melbourne.

Strathprints is designed to allow users to access the research output of the University of Strathclyde. Copyright © and Moral Rights for the papers on this site are retained by the individual authors and/or other copyright owners. You may not engage in further distribution of the material for any profitmaking activities or any commercial gain. You may freely distribute both the url (<http://strathprints.strath.ac.uk/>) and the content of this paper for research or study, educational, or not-for-profit purposes without prior permission or charge.

Any correspondence concerning this service should be sent to Strathprints administrator: <mailto:strathprints@strath.ac.uk>

Using Real-Time Simulation to Assess the Impact of a High Penetration of LV connected Microgeneration on the Wider System Performance During Severe Low Frequency

Abdullah Swissi Emhemed, Paul Crolla, and Graeme M. Burt

Institute for Energy and Environment, Department of Electronic and Electrical Engineering, University of Strathclyde, Glasgow, Scotland
(paul.crolla, g.burt)@eee.strath.ac.uk

Abstract- In addition to other measures such as energy saving, the adoption of a large amount of microgeneration driven by renewable and low carbon energy resources is expected to have the potential to reduce losses associated with producing and delivering electricity, combat climate change and fuel poverty, and improve the overall system performance. However, incorporating a substantial volume of microgeneration within a system that is not designed for such a paradigm could lead to conflicts in the operating strategies of the new and existing centralized generation technologies. This paper investigates the impact of tripping substantial volumes of LV connected microgeneration on the dynamic performance of a large system during significant low frequency events. An initial dynamic model of the UK system based on a number of coherent areas as identified in the UK Transmission Seven Year Statement (SYS) has been developed within a real time digital simulator (RTDS) and this paper presents the early study results.

I. INTRODUCTION

Significant international attention has been given to setting targets to reduce global greenhouse gases (GHG) emissions by 30% by year 2020, and 60-80% by 2050 in respect to 1990 level [1]. The EU countries on their own have made an independent commitment to cut the EU emissions to at least 20% by 2020 [1]. In parallel to the EU, the UK government has set mid and long-term national targets to cut GHG emissions by 26% by 2020 and up to 80% by 2050 compared to 1990 levels [1]. To meet these targets the EU and other developed countries have set a demanding target to provide a considerable amount of their electricity generation from renewable and highly efficient energy sources, and implement energy saving measures[2].

The adoption of large amounts of local generation such as microgeneration driven by renewable and low carbon energy resources is expected to have the potential to combat climate change, and reduce the losses associated with producing and delivering electricity. Using the UK long term target as an example, a study commissioned by the Department of Trade and Industry (DTI) of the UK and carried out by the Energy Saving Trust has suggested that 30-40% of the UK's electricity demands should be met through microgeneration technologies connected to distribution networks by 2050 to

meet the UK's 2050 target [3], though a new strategy is currently out for consultation.

In order to encourage the uptake of large amounts of microgeneration, there are a number of technical and political actions that have been taken by different countries in the world. Reference [4] discusses the incentives for microgeneration development in the USA and Europe, and states that the UK, USA, Germany, China, and France who are leading in microgeneration implementation have introduced numbers of policies encouraging the promotion of microgeneration [4]. These steps are summarized from [4] as following:

- The introduction of Renewable Energy Certificates (RECs) was to ensure that a certain amount of power is produced from renewable sources. RECs have already been implemented in the USA.
- The application of a feed-in-tariffs (FITs) policy to encourage individuals and small business to install their own renewable energy sources. The FITs make it obligatory for utilities to buy electricity provided from renewables. The FITs mechanism is seen as one of the most effective way for encouraging the adoption of renewable and efficient microgeneration [4] [5].
- The introduction of Renewable Obligation Certificates (ROC) by the UK government ensures

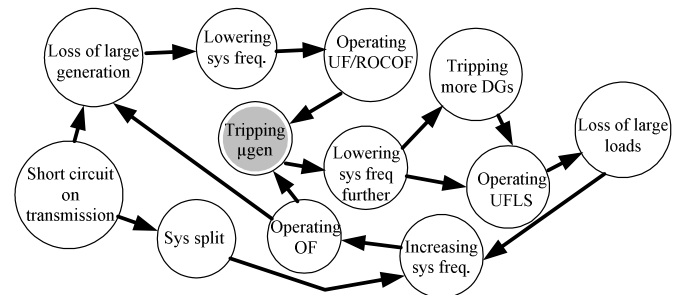

Fig. 1. The sequences of the events accompanying a frequency disturbance

that energy suppliers purchase at least 8% of their supplied electrical power from renewable sources.

In addition to the tariffs and simplified licensing certificates for microgeneration implementation, the introduction of the European standard EN50438 [6], which specifies the technical requirements for the connection of microgeneration in parallel with public low-voltage distribution networks, and the engineering recommendation document G83/1[7] in the UK for small sources connection, have all created a market for microgeneration and stimulated the increase of microgeneration connection to public grids.

However, incorporating a substantial volume of microgeneration within a system that is not designed for such a generation mix could lead to a number of technical issues. It is very important to understand the impact of a large penetration of microgeneration performance on the host system during different system conditions. There are numbers of previous studies that have investigated the technical issues surrounding the connection of a large number of microgenerators to distribution networks. The studies such as those reported in [8] [9-11] were aimed at addressing the impact on local voltages. In addition, the transient performance of distribution systems incorporating a large penetration of LV connected microgeneration under fault conditions has been investigated by the authors in [12, 13]. Most of these studies have considered the impacts of microgeneration on local systems. The technical issues caused by the widespread deployment of microgeneration in terms of wider system impact have not received significant attention.

This paper investigates the effect of tripping a substantial volume of LV connected microgeneration on the dynamic performance of a large power system during significant low frequency events. The paper provides the following contributions: the impact of low frequency disturbances on microgeneration dynamic performance is discussed in the paper. In addition, a test network model which represents a simplified dynamic model of the UK system based on the UK Transmission Seven Year Statement (SYS) provided by National Grid (NGET) [14] is developed using real time digital simulation (RTDS). The dynamic response of the developed large power system model during low frequency disturbances is investigated, and the effects of a high penetration of microgeneration during these disturbances on the system frequency is analyzed.

II. THE IMPACT OF LOW FREQUENCY EVENTS ON MICROGENERATION

Large frequency disturbances are normally caused by a significant imbalance between generation and load which can be caused by loss of large amount of generation or significant volumes of load. Fig. 1 shows a number of fault sources that may lead to large frequency disturbances. Loss of large

TABLE I
ER G83/1 FREQUENCY PROTECTION SETTINGS

Parameter	Trip setting	Trip time
Over frequency	50.5 Hz (50 Hz+1%)	0.5sec
Under frequency	47 Hz (50-6%)	0.5sec

amounts of generation could lead to a large drop in system frequency. Low frequency if sustained can lead to tripping of connected generators and loads. Over excitation protection is used to protect the generator and step-up transformer from damage due to the heat caused by excessive magnetic flux resulting from low frequency.

An analysis of the low frequency event in the UK on the 27th May 2008 [15] has shown that distributed generation (DGs) connected at MV distribution networks presented as a negative contributing factor to the events because of their unexpected tripping. During the UK event, the DGs tripped before the frequency reached 48.8Hz, which is the value that should initiate under frequency load shedding (UFLS). According to the protection settings recommended by Engineering Recommendations G83/1 [7] and G59/1 [16] and listed in Table I, the DGs should not trip on low frequency unless the frequency reaches 47Hz.

Compared to other DGs, microgeneration are more sensitive due to their smaller size. This may lead to tripping of large amounts of microgeneration during significant low frequency events. Fig. 1 above explains the possible impacts of tripping microgeneration on the dynamic system performance during low frequency events. The impact may increase the size of the total generation loss, and hasten the frequency drops and may lead to more consequential disconnection of loads. In order to understand to what extent tripping of microgeneration due to low frequency events will impact the system performance, the dynamic network model and studies in the next sections are of value.

III. TEST NETWORK MODEL

The network model used for the simulation studies is shown as a single line diagram in Fig. 2, and it has been developed within a real time digital simulator (RTDS). The network represents a simplified 13-bus dynamic model of the UK system based on eight areas as identified in the UK Transmission Seven Year Statement (SYS) [14] as shown in Fig. 3 (a).

In each area, the generators are modeled as aggregated large machines based on the type of technologies. For example, the generation in area 1 as shown in Fig 3. (a) and representing the north of Scotland is modeled by using three large generators run by three different turbines, hydro, steam, and gas. The GAST and HYG0V models from the RSCAD library are used to represent the gas and hydro turbines respectively and the associated speed governors [17]. The IEEE ST1 type excitation system given in [18] is used for

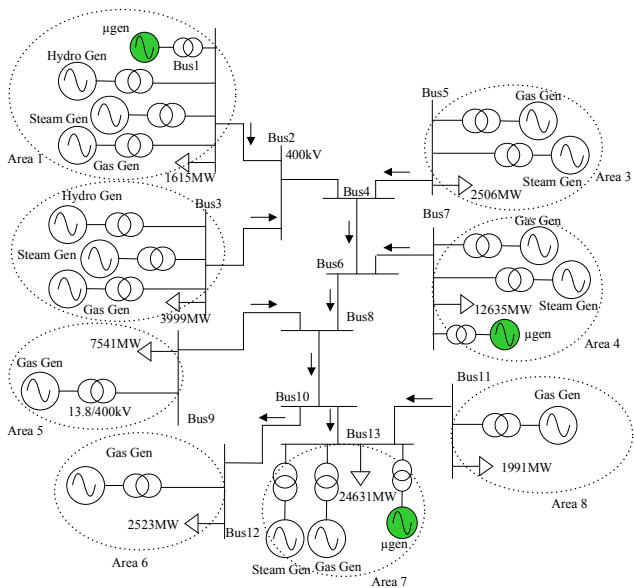

Fig. 2. The test network model. With the different areas circled in dotted lines. Each generation type in a particular area is represented by a single generator.

each generator. The parameters for gas and hydro turbines, governors, and exciters are taken from typical data available in [19]. For steam turbine models, a generic speed-governing and steam turbine IEEE1 model as given in [17] and [18] have been used. The parameters of steam turbine and governor models are taken from [19]

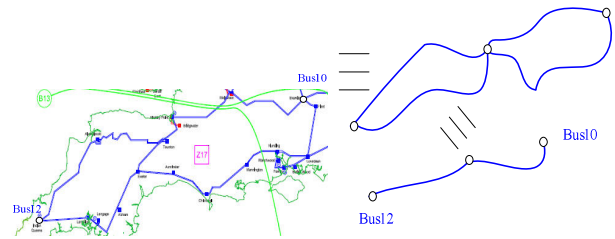

Fig. 4. The equivalent 400kV line between area 6 and 7

The distributed load is modeled as a fixed real and reactive power based on the average values given in [14]. A permanent droop loop with 4 to 5% speed droop is included as a part of the speed governor of each machine in order for the system load to be shared among multiple generators. The share between the generators is controlled by adjusting the load-frequency reference of the governor of each generator.

The actual interconnections of the UK 400kV transmission network as given in [14] and shown in Fig 3 (b) is simplified in the model to connect the eight areas together. The model of network is based on a selection of all 400kV circuits in each area being represented by one equivalent 400kV line. Currently, it is assumed that all the lines connected to the same substation are connected to the same busbar, and the equivalent of these lines is calculated to be equal to the lines

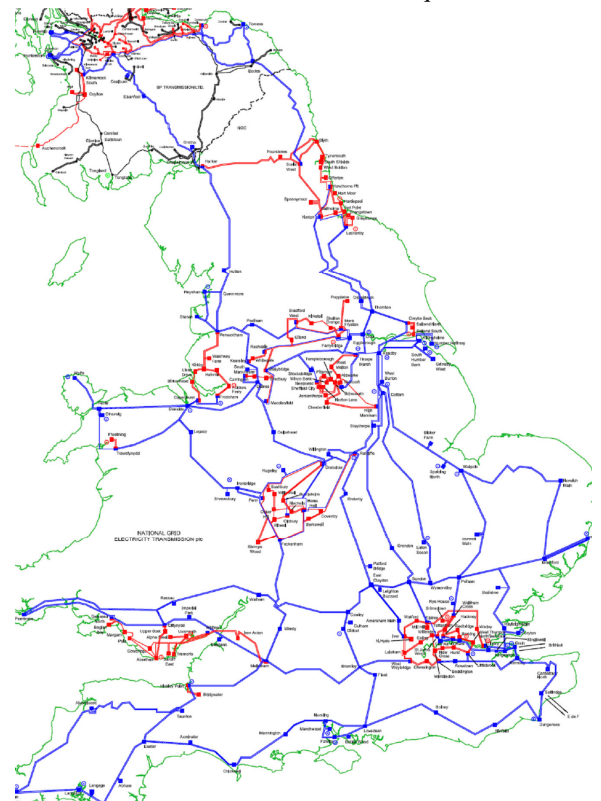
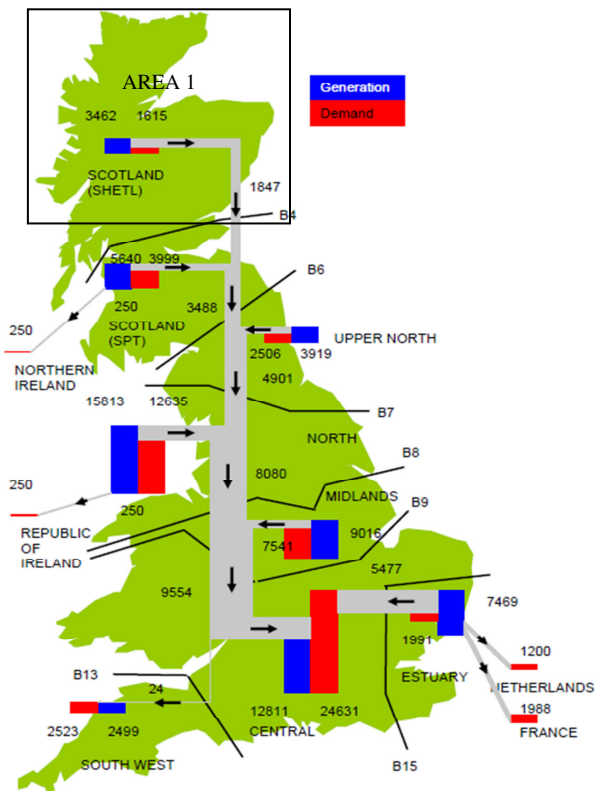

Fig. 3. [14] (a) power flow pattern of the UK power system, (b) 400kV UK transmission networks

in parallel. As an example, Fig. 4 shows how the equivalent circuit between bus10 and bus 12 in Fig. 2 is calculated. All the parameters of the 400kV lines are taken from [14].

The microgeneration connected to the test network as shown in Fig. 2 is modeled as aggregated generators representing all the microgeneration connected to the area. For the study shown here, microgeneration is represented in three different areas: area1 representing the north of the UK, area 4 the middle, and area 7 the south of the UK.

IV. SIMULATION AND STUDIES

In order to investigate the impact of nuisance tripping of microgeneration on the network dynamic performance during low frequency events a real-time simulation of the GB Grid was created. The reason for using real-time simulation is that in the future the test cases could be used in to control a real-time hardware-in-the-loop set-up, coupling the simulation to a real 3-phase microgrid via a motor-generator set. Doing this would enable the demonstration of the effect of grid dynamics on real inverter connected hardware and any algorithms that could be used to mitigate the effects. Three different cases have been considered.

Case 1: in this case, a large frequency disturbance is applied to the network by tripping 1500MW of generation from area1. In this scenario, the microgeneration is assumed to remain connected, and the impact on the frequency response is quantified. Fig. 5 shows the frequency deviation when 1500MW generation is disconnected from area 1. The frequency dropped to 49.73Hz.

Case2: the same amount of centrally dispatched generation as in case 1 is disconnected, but after 3.25 seconds a further 500MW of microgeneration in areas 1, 4, and 7 is disconnected. This has increased the drop in the frequency to reach almost 49.5Hz as shown in Fig. 5.

Case3: in this case, a larger amount of microgeneration is disconnected following the frequency drop initiated by tripping large plant supplies of 1500MW. It is assumed that in each area 1, 4, and 7, 1GW of microgeneration is disconnected. In this case, the total loss of microgeneration has led to the maximum secured loss of power being exceeded. The system frequency has dropped further very sharply, and reduced to less than 48.8Hz (i.e. enough to initiate the under frequency load shedding) as shown in Fig. 5. This will lead to the additional disconnection of thousands of consumers. In such a condition, the presence of microgeneration would be seen as a negative factor if they trip during low frequency events before 48.8Hz. The study of the paper has considered 3GW as maximum amount of microgeneration connected to the system. But, according to [20] the future scenarios developed in, the total amount of microgeneration in the UK could reach 10GW by 2050. Such considerable volumes must prove more resilient during low frequency events and demonstrate better stability down to

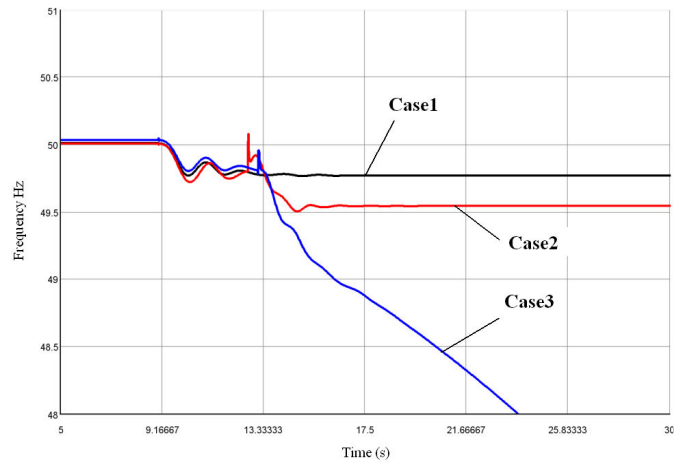

Fig. 5. Frequency response during loss of generation for Cases 1-3.

47Hz as stated in ER G83/1 [7] to avoid hastening the frequency drop, increasing the loss of loads and generation minimising the risk of blackouts. This may require more accuracy in frequency measurement, better ride through resilience, and more careful protection setting of microgeneration to avoid such undesirable consequences.

V. OUTCOME OF RESEARCH

Based on the results of the above limited study the University of Strathclyde was commissioned to write an Engineering Technical Report by the United Kingdom's Energy Networks Association. This technical report was created by using power system models created on the RTDS (Real-Time Digital Simulator) platform. This platform is well-suited to the testing of protection relays as it runs in real-time and has numerous outputs and inputs that enable control and protection equipment to be easily connected.

A. Overview of UK ETR 139 LOM test procedure

Engineering Technical Report 139 proposes a set of test procedures to test the Loss of Mains (LOM) protection systems of distributed generation connected to the 11kV and 33kV distribution networks. This set of procedures uses a mixture of actual, existing networks along with fictitious, generic ones to represent as many types of possible distribution network configurations present in the GB Grid. Some of these networks come from the UK Generic Distribution System (UKGDS) repository [21]. The procedure has two main criteria for system acceptance, sensitivity and stability. The sensitivity tests consider the detection of purely loss of mains faults with different levels of local load/ generation imbalances; the stability tests consider the action of the protection algorithm under faults that are not LOM and thus the relay should generally remain stable. However, for some conditions, for example a fault with 50% retained voltage (ph-e, ph-ph, 3-ph) it is acceptable for the LOM relay to trip in the presence of a 3-phase fault but not for the other types. The usefulness of this test procedure is that it can be used to test all types of LOM

algorithms with no changes. The methodology described in [22] could be used to create test procedures for jurisdictions other than the United Kingdom.

The paper [22] shows that more system wide studies will be required in the future when considering the integration of small scale distributed generation. These studies will become more complicated in the future as microgeneration will be required to provide ancillary services in the future rather than disconnect in the face of grid disturbances. Further the future smart grid will require the use of automatic network management systems [23] that will take control of generation and network switching in an intelligent autonomous manner; only through detailed system studies combined with real-time simulation interacting with the devices will operators be able to test and confirm that particular schemes will operate safely and satisfactorily.

VI. CONCLUSION

This paper has investigated the impact of tripping large amounts of LV connected microgeneration, due to low system frequency events, on the dynamic performance of a large power system. The output of the paper has shown that nuisance microgeneration tripping due to low frequency events can significantly affect the system operating conditions by lowering the frequency further, and accelerating the action of under frequency load shedding protection. The quantification of such a negative contribution can better inform specification of suitable remedial control measures to make active consumers and local generation support the wider system during disturbances thus protecting large numbers of consumers from being disconnected. Further work is being undertaken to review the models and include protection actions in order to better appraise the risks involved at varying levels of microgeneration and the effectiveness of alternative measures. This research should advise the steps required to ensure that the integration of larger volumes of microgeneration does not significantly increase the threat of system events having greater impact on the disconnection of consumers. This paper has also presented a short summary of the ETR 139 report created for an industrial client based on the conclusions of this original work.

ACKNOWLEDGEMENTS

This research was supported by the UK Research Councils' Energy Programme as part of the Supergen FlexNet Consortium (grant EP/E04011X/1) and the Supergen HiDEF Consortium (grant EP/G031681/1) and also by the EU FP6 DERlab project.

REFERENCES

- [1] "EU action against climate change: Leading global action to 2020 and beyond," D.-G. f. t. Environment, Ed., ed: European Communities, 2009.
- [2] *Promotion of the use of energy from renewable sources*, E. Commission, 2009.
- [3] "DTI Power from the People: Microgeneration Strategy," D. o. T. a. Industry, Ed., ed. London: Stationary Office.
- [4] A. E. Jones, Irwin, M., and Izadian, A, "Incentives for Microgeneration Development in the U.S. and Europe," presented at the IECON 2010-36th Annual Conference on IEEE Industrial Electronics Society, Glendale, AZ, USA, 2010.
- [5] N. Melo, Prata, R., Govclaves, R., Mira, "Microgeneration in Portugal-DEP Experience and Future Perspective," presented at the 20th International Conference on Electricity Distribution Prague, 2009.
- [6] CENELEC, "Requirement for the Connection of Micro-Generators in Parallel with Public Low-Voltage Distribution Networks," vol. EN50438-2007, ed: European Commission, 2007.
- [7] E. N. Association, "Recommendations for the connection of small-scale embedded generators (up to 16A per phase) in parallel with public low-voltage distribution networks," vol. ER G83/1, ed. London, 2003.
- [8] A. D. P. Smart, A. Maloyd, A. Causebrook, S. Cowdroy, "Accommodating Distributed Generation," D. o. T. a. Industry, Ed., ed. London, 2006.
- [9] S. P. S. Ingram, K. Jackson, "The Impact of Small Scale Embedded Generation on the Operating Parameters of Distribution Networks," D. o. T. a. Industry, Ed., ed, 2003.
- [10] K. T. Y. Zhu, "Optimal Distribution Power Flow for Systems with Distributed Energy Resources," *Electrical Power and Energy Systems*, vol. 29, pp. 260-267, 2007.
- [11] M. Braun, "Technological Control Capabilities of DER to Provide Future Ancillary Services," *International Journal of Distributed Energy Resources*, vol. 3, pp. 191-206, 2007.
- [12] A. S. Emhemed, *et al.*, "Transient performance analysis of low voltage connected microgeneration," in *Power and Energy Society General Meeting - Conversion and Delivery of Electrical Energy in the 21st Century, 2008 IEEE*, 2008, pp. 1-6.
- [13] A. S. Emhemed, *et al.*, "Transient performance analysis of single-phase induction generators for microgeneration applications," in *Power Electronics, Machines and Drives, 2008. PEMD 2008. 4th IET Conference on*, 2008, pp. 345-349.
- [14] "GB National Electricity System Seven Year Statement," National Grid Electricity Transmission plc.2010.
- [15] "Report of the investigation into the automatic demand disconnection following multiple generation losses and the demand control response that occurred on the 27th May 2008," National Grid Electricity Transmission plc.2008.

- [16] "Engineering Recommendation G59/1, "Recommendation for the Connection of Embedded Generating Plant to the Public Electricity Suppliers' Distribution Systems", Energy Networks Association, London 1991.
- [17] "Real Time Digital Simulator Tutorial Manual (RSCAD ver)," RTDS Inc. 2008.
- [18] P. Kundur, *Power Systems Stability and Control*. New York: McGraw-Hill, 1994.
- [19] V. A. M. Azubalis, A. Jonaities, R. Ponelis, "Identification of Model Parameters of Steam Turbine and Governor," *Oil Shale - Estonian Academy Publishers*, vol. 26, pp. 254-268, 2009.
- [20] D. F. G. Ault, N. Hughes, "Long-Term Electricity Network Scenarios (LENS) for Great Britain in 2050," OFGEM 2008.
- [21] United Kingdom Generic Distribution System [Online]. Available: <http://monaco.eee.strath.ac.uk/ukgds/>
- [22] A. Dysko, *et al.*, "Testing methodology for LOM protection performance assessment," in *Developments in Power System Protection (DPSP 2010). Managing the Change, 10th IET International Conference on*, 2010, pp. 1-5.
- [23] E. M. Davidson, *et al.*, "AuRA-NMS: Towards the delivery of smarter distribution networks through the application of multi-agent systems technology," in *Power and Energy Society General Meeting - Conversion and Delivery of Electrical Energy in the 21st Century, 2008 IEEE*, 2008, pp. 1-6.