



Strathprints Institutional Repository

Counsell, John and Stewart, Matt John and Logan, Rufus and Doran, Sean and Ward, Wayne (2011) *A novel DSM philosophy for building integrated renewable systems*. In: 2nd International Conference in Microgeneration and Related Technologies, Glasgow April 4-6 2011, 2011-03-31.

Strathprints is designed to allow users to access the research output of the University of Strathclyde. Copyright © and Moral Rights for the papers on this site are retained by the individual authors and/or other copyright owners. You may not engage in further distribution of the material for any profitmaking activities or any commercial gain. You may freely distribute both the url (<http://strathprints.strath.ac.uk/>) and the content of this paper for research or study, educational, or not-for-profit purposes without prior permission or charge.

Any correspondence concerning this service should be sent to Strathprints administrator: <mailto:strathprints@strath.ac.uk>

A NOVEL ENERGY MANAGEMENT PHILOSOPHY FOR BUILDING INTEGRATED RENEWABLE SYSTEMS

Professor John M. Counsell⁺, Matt J. Stewart⁺, Rufus Logan^{*}

⁺University of Strathclyde, Glasgow, Scotland

^{*}BRE (Scotland) Limited

ABSTRACT

This paper presents an overview of a novel concept in IT network design and power control focused on matching building integrated renewable power generation with local demands. It describes how this is achieved through combination of energy demand reduction and dynamic utilisation of embedded energy storage in a robust, efficient and cost effective manner. A brief overview of the main features of the design is given in terms of its intended benefits as an integrated system. The load components and distribution topology are described for this experimental system within the limits set by the capacity, capabilities and desired function of the network. Power supply to the network is described as including a back-up source to the photovoltaic (PV) source to add functionality and stability with no requirements for undesirable exporting of excess PV generation. The necessary configuration of the renewable array integrating with the network is also highlighted with an example compatible solar module device.

A trial of the technology and demand management control in a high profile office building is described. This trial in a live working environment is providing invaluable real world data to compare against modelling and network simulation results.

INTRODUCTION

The potential for micro-generation and renewable technologies to mitigate overall carbon emissions by off-setting electricity consumption in the built environment is highly significant. However, given the intermittent

nature of renewable generation, large numbers of embedded non-dispatchable renewable generators present substantial and increasingly costly management risks for power network operators due to the mismatch between supply and demand that prevents the demand being reliably utilised (Strbac 2007). State of the art DSM methods and systems aim to reduce this uncertainty and risk by improving the match through re-structuring of the demand profile (Counsell et al, 1997), but these systems can be difficult to control, expensive to deploy and inefficient since the convention is to utilise the larger network to transfer renewable generation to a demand while also providing a 'buffer' for the renewable and security for the load (Infield et al, 2007). Traditional DSM systems therefore tend towards the network operator as the primary stakeholder which then detracts value from local ownership of the system.

The proposed solution; Building Integrated Ethernet Networks with Renewable Power Generation (BIEN-RPG) takes a holistic and integrated approach to ICT power systems design within commercial buildings, minimising deployment costs through utilising ubiquitous network resources, improving efficiency through DC network architecture while reducing demand via sensible ICT procurement. Dependence on external supply is reduced by integrating a renewable source directly as part of the building's electricity fuel mix. Starting from the novel philosophy that the primary desired source is the renewable, the proposed system architecture has been designed and selected with a specific and novel demand management control type in mind which aims to utilise the renewable source whenever available to its full capacity through management of network

embedded energy storage while also allowing continuous and uninterrupted security of supply to the load. The full benefits of this approach can be measured directly in increased value of ownership of the system, contributing to Carbon Reduction Commitments while generating a revenue stream and off-setting electricity costs.

SYSTEM DESCRIPTION

Low Power ICT Equipment

More than in any other sector, ownership of and dependence on communications-enabled equipment; computers, media devices in commercial buildings is growing fastest. This increase in ICT density not only results in greater cumulative energy waste through need for low power AC/DC converters for each individual device, but can also be detrimental to thermal comfort, cooling energy requirement and even affecting reachability of environmental controls in the workplace (Fraunhofer, 2006). Sensible procurement can result in dramatic reduction in energy consumption and alleviate these direct and indirect energy consumption and satisfaction issues. Recent market research in this area shows, for example, modern mid-range mass market mobile PC's consuming less than 40W maximum and so-called thin client fixed desktop PC's at less than 20W with several units rated less than 10W. Similarly, improvements in screen technologies have resulted in available modern 22" LED backlit LCD monitor screens consuming less than 20W in operation.

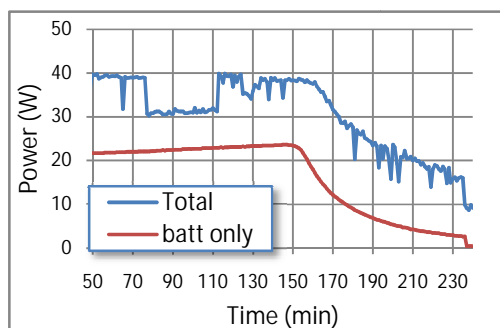

Figure 1 - Power Profile of a Representative BIEN-RPG Compatible Portable ICT Device

The traces in Figure1 detail battery and overall device power consumption for a modern low power notebook class mobile device sampled at 1Hz and show consumption during a typical charging cycle to be less than 40W with the battery itself consuming less than 25W at peak. Fully charged idling power was below 12W. Figure 2 shows the consumption profile and variability of a modern computer monitor rated at 27W. This typically describes the two key functional components of an office desk in terms of actual consumption profile versus published power rating.

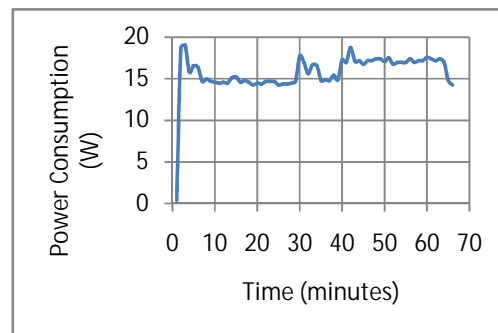

Figure 2 - Power Profile of a representative BIEN-RPG Compatible ICT Device

Power over Ethernet Networks

Modern office environments use ubiquitous data communications protocols between networked ICT devices – Local Area Networks (LAN) over CAT cabling. These building integrated networks can also provide power via these same cable infrastructures using amendments to the standard IEEE802.3 suite of protocols; termed Power over Ethernet (PoE) at a user safe low voltage of between 52-57VDC.

Type1 PoE, ratified in 2005, allows up to 15.4W to be delivered and provides the method by which hundreds of millions of IP telephones, security cameras and wireless access points are already powered (VDC, 2008).

Type2 PoE or PoE+, ratified 2009, allows up to 72W per channel to be delivered over CAT5e and above cables (IEEE, 2009). PoE networks feature three standardised components in a radial configuration; supply of PoE power is to an interface which splits power and data streams for use by an end-device, termed a

Powered Device interface (PD) or ‘splitter’. These components are integrated within legacy low power PoE devices but are also available and used here as external interface units, allowing non-PoE devices to be interfaced and powered via the Ethernet network.

DC power distribution in PoE+ is via CAT5e or above standard Ethernet cable to a TIA ISO/IEC defined installation standard of 100m maximum length and 5kW per cable bundle at an ambient 45°C, allowing thermal dissipation of up to 6W per channel. A source of power for a channel, termed Power Source Equipment (PSE) can be fully integrated within an Ethernet switch or router, known as an endspan, or can be deployed as a stand-alone device, known as a midspan, to combine data and power in a single output. Midspan power injection equipment enables cost effective retro-fit of the technology to existing Ethernet networks.

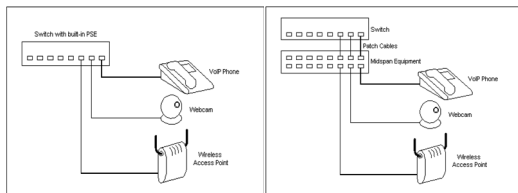

Figures 3a and 3b – Endspan and Midspan PoE Power Injection Topologies

Renewable Energy Integration and Security of Supply

Security of supply is paramount to any significant power system and is provided in this system by connection within the power supply to the network of a back-up source. In the present case, this back-up is provided by the AC grid via the only AC/DC converter connected to the entire network. Photovoltaics are especially suited to BIEN-RPG since these devices generate power in the form used by both the network and loads. However, BIEN-RPG deviates from a conventional PV array in that the magnitude of voltage generated is low and deliberately aimed at being close to or within the range demanded by the PoE network – a voltage range more common to off-grid 48V battery charging applications. Again, the system

shows flexibility in accepting a range of potential array module products and several technologies to give the required voltage. For example, four BP350U poly-crystalline modules in series give 69.2Vp at STC.

| Electrical Characteristics ² | BP 350 |
|---|--|
| Maximum power (P_{max}) ³ | 50W |
| Voltage at P_{max} (V_{mp}) | 17.3V |
| Current at P_{max} (I_{mp}) | 2.89A |
| Warranted minimum P_{max} | 45W |
| Short-circuit current (I_{sc}) | 3.17A |
| Open-circuit voltage (V_{oc}) | 21.8V |
| Temperature coefficient of I_{sc} | (0.065±0.015)%/ °C |
| Temperature coefficient of V_{oc} | -180±10)mV/°C |
| Temperature coefficient of power | -0.5±0.05)%/ °C |
| NOCT (Air 20°C; Sun 0.8kW/m ² ; wind 1m/s) | 47±2°C |
| Maximum series fuse rating | 20A |
| Maximum system voltage | 600V (U.S. NEC & IEC 61215 rating) 1000V (TÜV Rheinland rating) |

Table 1 – Example Compatible PV module Characteristics

This voltage, after thermal and other parasitic losses, can be shown to fall, for most operating conditions (Thevenard, 2005), within the range required of the network. Multiples of 4s-1p array configurations can be added in parallel to increase current and generating capacity.

This concludes an overview of the key system components and main network connections and are summarised in schematic form in Figure 3.

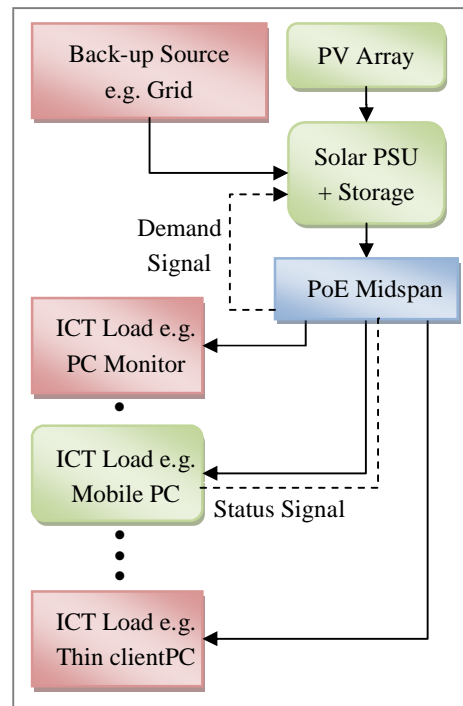

Figure 3 - Schematic of BIEN-RPG Components and Connections

Additional desirable features of modern Ethernet networks are back-up power supplies (UPS) and redundant power supplies (RPS); included to ensure continued independent reliability in operation irrespective of the state of any external supply. BIEN-RPG can utilise UPS components to artificially adjust and maintain the power diversity of the network.

Monitoring System Design

Designing a supervisory or monitoring system involves design of a small independent power and data network in its own right. In keeping with the theme of powering devices over Ethernet, it is proposed that PoE be used to supply this power to the system sensors while also providing a data channel for the sensor information and hence standard off-the-shelf equipment can be used, the result being an IP-enabled sensor framework. An example of a simple, low cost, IP-enabled sensor interface used in the system is shown in Figure 4. Other necessary input data comes from the network devices themselves at no additional hardware cost.

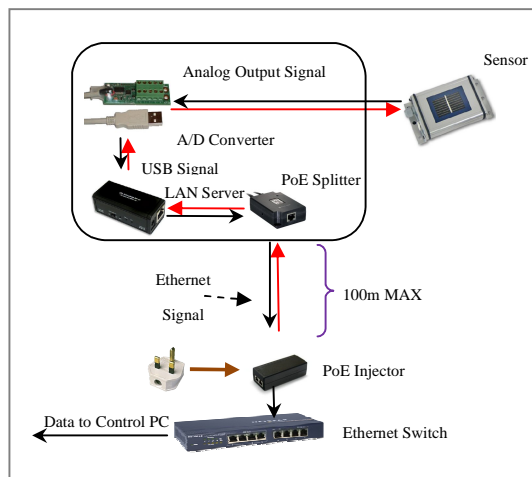

Figure 4 – Example of an IP-enabled PoE Powered Interface & Sensor

Advanced Control and Energy Management

Research has also indicated that conventional DSM control strategies are not best suited to this particular network and topology. Therefore, the system employs a novel and patented energy management control to actively match

renewable supply with available capacity in energy storage elements embedded within the network to achieve full use of the renewable source whenever available and use stored renewable energy when not available before relying on back-up from an alternative source such as the AC grid.

BIEN-RPG SYSTEM TRIALS

This novel and experimental integrated system is presently undergoing staged deployment and trial at a high profile government building in Wales where initial assumptions regarding compatibility, functionality, robustness and user satisfaction of non-PoE devices being powered via a PoE network are being tested in a demanding environment. Further trials and system developments are planned at a school in Hertfordshire and at BRE's showcase Innovation Park in Watford with goals of demonstrating system safety and refining design criteria. These trials are providing evidence for the cost and carbon savings claims made by modelling and simulation of the system for particular applications and a range of loading regimes.

ANALYSIS

Claims made by theoretical analysis include increased delivery efficiency of renewable power to a local load and therefore greater ROI through incentives such as the Feed-In Tariff with further off-set of high carbon import. Table 2 compares the overall delivery efficiency of renewable energy to a load in a conventional grid-connected system versus that of the proposed topology.

In addition to a significant increase in delivery efficiency, theoretical calculations show that reductions in energy consumption could be as great as 90% if shifting from a conventionally powered fixed desktop to PV powered mobile devices using BIEN-RPG. Further, such a reduction in demand is expected to reduce area cooling requirement by a similar margin or more in ICT dense areas, mitigating office operational energy trends forecast by Jenkins (Jenkins et al, 2008).

| SYSTEM COMPONENTS | CONVENTIONAL SYSTEM | BIEN-RPG |
|------------------------|---------------------|-------------|
| PV Array | 1.00 | 1.00 |
| DC Loss | 0.99 | 0.97 |
| MPPT/Inverter | 0.90 | N/A |
| Grid Loss | 0.95 | N/A |
| CAT5e Loss | N/A | 0.90 – 1.00 |
| AC Adapter Loss | | |
| Linear PSU | 0.40 – 0.65 | N/A |
| SMPS | 0.60 – 0.85 | N/A |
| PD Interface | N/A | 0.85 |
| Total De-rating | | |
| Worst Case | 0.34 | 0.74 |
| Best Case | 0.72 | 0.82 |

Table 2 - Comparison of Conventional and BIEN-RPG Renewable Delivery Efficiency

The controller's ability to utilise the maximum power available from the PV arrays ensures that no power generated by the renewable source is lost while the relative scales of the components in the complete system ensures that no valuable local renewable generation need be exported to the larger grid at low return on investment.

Finally, PoE DC powering of devices replaces non-power factor corrected AC adapters as defined by the Energy Star Program for Computers which impacts positively on reachability and control of the larger grid and lessens the need for expensive corrective measures at local sub-station level.

It is also noted that this system can contribute to award of BREEAM Innovation Credits under ENE5 criteria.

DISCUSSION

This system has achieved its preliminary design goal of using commercially available components (with some developed especially for this particular system architecture) and equipment throughout to provide the functionality required.

Important initial field testing of non-PoE devices being powered over Ethernet via an external PD interface in a working environment has been successful, demonstrating that the standard IEEE PoE protocol implementation and hardware is robust enough to withstand surge currents at device start-up or sudden connect/

disconnect without damage to either the load device or the PoE hardware.

Simulation of load and network behaviour using models descriptive of the system elements (Jones, Underwood, 2002) and (Gao et al. 2002) with the patented control suggests a significant improvement in matching renewable supply with demand over alternative DSM controller types while also maintaining stability of the system.

Further simulation refined by field trial results are expected to verify and aid in optimising the sizing of the system components such as the minimum generation and storage capacities required for a particular topology, loading regime and device type.

CONCLUSION

This paper has given a brief overview of a novel network topology and control suited to application of demand management. The target applications of the BIEN network are described as commercial offices and buildings with medium to high density of ICT equipment. The system components are described within the limitations and constraints of this network and the intended control strategy. A series of live trials intend to assess fitness for purpose and give data to verify and validate the performance and robustness of the complete BIEN-RPG system design described in this paper.

REFERENCES

- ANSI/ IEEE802.3-2009, Carrier Sense Multiple Access with Collision Detection (CSMA/CD) Access Method and Physical Layer Specifications, Amendment 3: Data Terminal Equipment (DTE) Power via the Media Dependant Interface (MDI) Enhancements. ISBN: 9780738160436
- Counsell [GB], Reeves [GB], Heating apparatus controlled to utilize lower cost energy. Patent publication: US5700993 (A), EC: G05D23/20G4C2, 23-12-1997.

Energy Star Program Requirements for Computers Version 5, Retrieved 2009

Gao et al, Dynamic Lithium-Ion Battery Model for System Simulation, IEEE Transactions on Components and Packaging Technologies, Vol. 25, Issue 3, 2002

Infield et al, Potential for Domestic Dynamic Demand Side Management in the UK, Power Engineering Society General Meeting IEEE, 2007.

Jenkins, Liu, Peacock, Climatic and Internal Factors Affecting Future UK Office Heating and Cooling Energy Consumption, Energy and Buildings, Vol 40, Issue 5, pp 874-881, 2008.

Jones, Underwood, A modelling Method for Building Integrated Photovoltaic Power Supply, Journal of Building Services Research and Technology 2002, Vol3, pp167-178, 2002.

Knermann et al, Environmental Comparison of the Relevance of PC and Thin Client Desktop Equipment for the Climate. Fraunhofer UMISCHT 2008.

Strbac et al, Impact of Wind Generation on the Operation and Development of the UK's Electricity Systems, Electric Power Systems Research, Vol 77, Issue 9, pp1214-1227, 2007.

Thevenard, Review and Recommendations for Improving the Modelling of Building Integrated Photovoltaic Systems, Proceedings of Building Simulation, Montreal, 2005.

Venture Development Corporation, 2008. Power over Ethernet (PoE): Global Market Demand Analysis. Retrieved 2009

