

Strathprints Institutional Repository

Zaher, Ammar and Cruden, A.J. and Booth, C.D. and Leithead, W.E. (2009) *Database management for high resolution condition monitoring of wind turbines*. In: The 44th International Universities' Power Engineering Conference, 2009-09-01 - 2009-09-04, Glasgow.

Strathprints is designed to allow users to access the research output of the University of Strathclyde. Copyright © and Moral Rights for the papers on this site are retained by the individual authors and/or other copyright owners. You may not engage in further distribution of the material for any profitmaking activities or any commercial gain. You may freely distribute both the url (<http://strathprints.strath.ac.uk/>) and the content of this paper for research or study, educational, or not-for-profit purposes without prior permission or charge.

Any correspondence concerning this service should be sent to Strathprints administrator: <mailto:strathprints@strath.ac.uk>

Database Management for High Resolution Condition Monitoring of Wind Turbines

Ammar Zaher
Dept. EEE, University of
Strathclyde
azaher@strath.ac.uk

Dr. Andrew Cruden
Dept. EEE, University
of Strathclyde

Dr. Campbell Booth
Dept. EEE, University of
Strathclyde

Prof. Bill Leithhead
Dept. EEE, University of
Strathclyde

Abstract- Wind turbine condition monitoring (CM) is an area of research which has been receiving a large amount of attention in the recent years. This has been influenced mainly by the recent uptake of wind farms being installed around the country. Operational and maintenance expertise in the area of wind turbine CM is therefore seen to be of growing importance but is yet to be well established in the industry due to its unverified economic benefits. The majority of the research which can be found in the literature has been based on simulation or test rig data, often due to the lack of availability of extensive historical data sets containing 'interesting' events, as well as the difficulties associated in gaining access to such data, due to its commercially sensitive nature. It can not be readily claimed, nor shown that laboratory based testing or simulations actually reflect real turbine operation, due to scaling, control and dynamic considerations. In order that different patterns of machine deterioration can be determined and detected in their incipient stages, precise high resolution data, of existing monitored parameters, should be sampled at frequencies higher than that is typically available in the integrated SCADA systems installed in most modern turbines today. This paper reports the design of a data acquisition platform which will be mounted on a 660kW VESTAS V47 wind turbine. Details of the monitoring equipment used, the installation requirements as well as the system architecture will be presented and discussed.

Index Terms—Data Acquisition system, Wind turbine, Condition Monitoring.

I. INTRODUCTION

Wind turbines have increased in scale and capacity over the recent years as the demand for wind farms increases with farms being installed all around the country [1]. An increase in the capacity of a wind turbine will result in a greater financial impact with regards to its manufacturing costs, as well as any experienced downtime due to the resulting increased drop in energy generation per turbine that experience failures. It is therefore imperative for wind farm operators to optimize the operation of their machines in order to achieve their overall profit objectives. With respect to the constant advances in

wind turbine technology, there has been significantly much less focus and research into the development of monitoring technologies that can be found in the literature. Most modern turbines utilize the integrated CM systems that are installed during their manufacture. These systems provide averaged measurands for a variety of monitored parameters. Extracting information from this averaged SCADA data is often difficult due to the limited set of parameters monitored and the low resolution nature of the data. The purpose of this research is to develop an advanced high resolution, increased parameter CM system [2] to explore the advantages that it offers over the onboard integrated CM systems installed on the turbine. Operators currently do not utilize the output of these integrated SCADA systems mainly due to the overwhelming volume of data which requires tedious and timely processing and also the fact that understanding and interpreting this data is not a straight forward process. While it may be argued that a high resolution CM system will inevitably result in higher volumes of data, processing of the data would ideally be an automated process. By having access to more parameters sampled at a high frequency, the ability to extract more detailed condition assessment information inherent within the data is possible and can be explored through the use of the system developed for the purpose of this research.

In order to develop a reliable condition monitoring system detailed analysis of real data recorded from an operating wind turbine has to be carried out. This paper will present details of a data acquisition (DAQ) platform for acquiring the raw data suitable for such analysis.

II. INSTALLATION SAFETY REQUIREMENTS

The design of the DAQ platform must conform to a number of requirements in order to be approved for installation by the industrial project partner. The platform will be installed on an operational 660KW VESTAS V47 wind turbine.

The first and foremost requirement implicates that the design must adhere to the strict operational and safety requirements in place at the wind farm site. The installation of the DAQ platform cannot affect the normal operation of the turbine in any way while also ensuring that it poses no threat to maintenance engineers once installed. The system design must be free from electrical connections between devices

installed at the top of the turbine in the nacelle and the bottom of the tower in order to remove any possibility of electrical noise interfering with the current integrated CM system signals. Any direct connections to the controller must feature an electrical isolation barrier again to prohibit electrical noise. The system must also be operational in terms of control and data collection from the bottom of the turbine without the need for interrupting the operation of the turbine. With regards to the installation of the system, it is necessary for the engineers to have completed recognized wind turbine climbing [3] and first aid courses [4], in order to be familiar with safe access, evacuation and rescue procedures. Risk assessment and method statement documents must also be prepared and accepted by the wind farm operators before the installation commences.

III. MONITORED PARAMETERS

There are a large number of parameters which can be monitored in a wind turbine. The CM system designed for this piece of research will monitor the main internal components whose mechanical health is critical for successful operation. By monitoring these components a better picture of the current state of the turbines' mechanical health can be established. In this way a more robust CM system can be developed leading to the possibility of accurately detecting problems in their incipient stages before they manifest into more serious failures causing undesirable downtime. This will allow for optimized wind farm operation where maintenance operations can be scheduled accordingly to maximize wind farm output. The data acquisition cards utilized for the system are limited to a single sampling rate across all channels. Therefore the chosen parameters for monitoring are divided into two groups which will be sampled at two different sampling rates, a low speed rate of 50Hz and a high speed of 20 kHz. The monitored parameters are acquired through the high speed and low speed DAQ devices connected through the PCI and USB interfaces of the computer respectively. Not all of the monitored parameters are recorded through the DAQ devices but are connected through other interfaces such as the USB port as well as the serial port of the PC. The list of sensors and the parameters they monitor, as well as their respective sampling rates are enclosed in Table I.

TABLE I
LIST OF SENSORS AND PARAMETERS MONITORED BY CM SYSTEM

Parameter	Sampling Rate
Temperature, gear bearing	50Hz
Temperature, generator	50Hz
External Air Temperature,	50Hz
Temperature Nacelle	50Hz
Temperature gear oil	50Hz
Rotor speed (Hall effect gear tooth sensors)	50Hz
Generator speed (Hall effect gear tooth	50Hz

sensors)	
Pitch position (linear actuator)	50Hz
Atmospheric Pressure (Barometric sensor)	50Hz
Humidity (Sensor P14 SMD)	50Hz
Wind speed (nacelle mounted wind anemometer)	50Hz
Wind direction (wind vane)	50Hz
Yaw direction (Digital compass)	8Hz
Structural Vibration - XY	1Hz
7 Hansford vibration sensors	20kHz
3 Phase Currents	20kHz
3 Phase Voltages	20kHz

The seven Hansford vibration sensors will be positioned to monitor a number of components as shown in figure 1. The vibration levels will be recorded at a sampling rate of 20 kHz for the generator, gearbox as well as main bearing in both the axial and radial axes. In order to conform to the industrial partner's requirements and avoid interference or modifications with existing systems and components, the sensors will be mounted with adhesive fixings instead of screwed fixings.

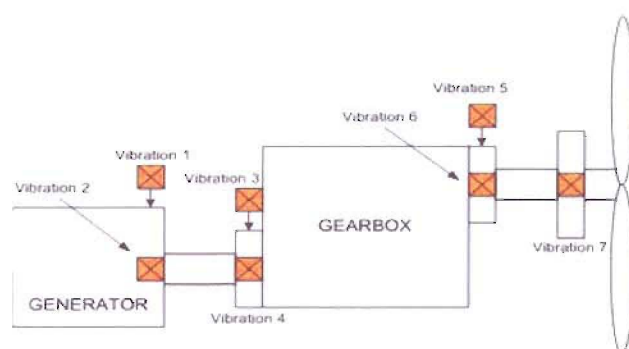

Figure 1: Vibration sensor layout

IV. CONDITION MONITORING SYSTEM DESIGN OVERVIEW

The system, as can be seen from figure 2, is composed of two PCs, PC 1 and PC 2 situated at the top of turbine in the nacelle and at the bottom of the tower respectively. PC 1 is responsible for the data acquisition process. It will collate the data through sensors connected to it through a number of interfaces. The majority of the sensors are connected through two DAQ devices that have a different maximum sampling rate and are connected through the USB port (Low speed 50Hz DAQ) and the PCI port (High speed 20 kHz DAQ). The parameters listed in table I at 50Hz and 20 kHz sampling rates are connected through the appropriate DAQ device according to the specified sampling rate. The digital compass and the structural vibration sensors are the exceptions and are

authorization from maintenance teams which will restrict access to a minimum.

V DATA ACQUISITION SOFTWARE ARCHITECTURE

The software responsible for acquiring the data streams via the DAQ devices is written and developed using LABVIEW version 8.5. The system is built around one main timing loop which controls the start and end time of data acquisition across all DAQ devices connected to the PC. This arrangement is depicted in figure 3.

In this way, the program can accommodate new DAQ devices if they are decided to be added at a later stage which can also be triggered and stopped through the main timing loop. The data acquisition process follows the steps depicted in the flow chart shown in figure 4. When the program is executed, the user interface (shown in figure 5) allows the user to configure the number of channels to be used per DAQ device as well as the desired sampling rate. This allows the program to accommodate varying sizes of storage space. The user also specifies the desired start time and end time to begin the data acquisition cycle. MYSQL tables [5] are automatically created for each DAQ device ready for data input before acquisition starts.

In order to speed up the writing of data to the MYSQL tables, the data is buffered and written to a sequence of 2GB text files (Maximum text file size in windows [6]) in separate temporary folders which are created on the

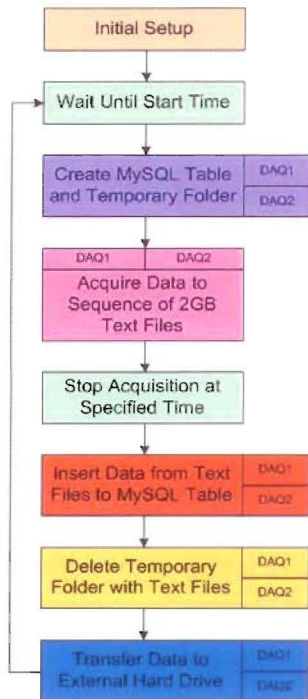

Figure 4: Data Acquisition process

computer's local hard drive. Data acquisition can then be performed simultaneously from the DAQ devices, without the slowdown of writing each individual sample to its appropriate MYSQL table. The optimal format for storing large volumes of data is using the Mysam MYSQL tables. While directly inserting data from the LABVIEW program into the MYSQL database using the LABSQL [7] (which is required to interface LABVIEW with MYSQL) would have been a more convenient approach, this only works well with low sampling rates where the data can be sent as individual samples. As the sensors are sampled at high sampling rates (20kHz) the stream of data must be buffered first being sent to temporary memory, and once the processor is free to deal with the request (usually a period of 1 second) the buffered data (around 20000 samples) is moved to the storage destination. Buffered data however cannot be directly input into MYSQL using LABSQL. The intermediate step of writing the data to temporary text files and then inserting them sequentially into the MYSQL table's resolves this issue. Once the copying procedure is complete the temporary text files are deleted to save space. The data which is now in the form of MYSQL tables can then be transmitted to the Ethernet high capacity hard drive connected to PC 2. This process then repeats where the program will sit idle waiting for the timing loop to trigger once again where a new table is created for each day.

The user interface for the program is shown in figure 5. The interface allows the user to make a number of changes which allow for data acquisition from more sensors should this be required. The controls are kept basic for ease of use as most of the functionality is automated and run behind the scenes hidden from the user to keep things simple. The user has control over selecting the number of channels required, the corresponding channels on the DAQ device and the sampling rate. When setting up the MYSQL tables for the database, the required data precision can be selected for the acquired data. The current status section to the lower half of the interface shows the number of scans written giving an indication of that the system is operational as well as the current table name the data is being written to.

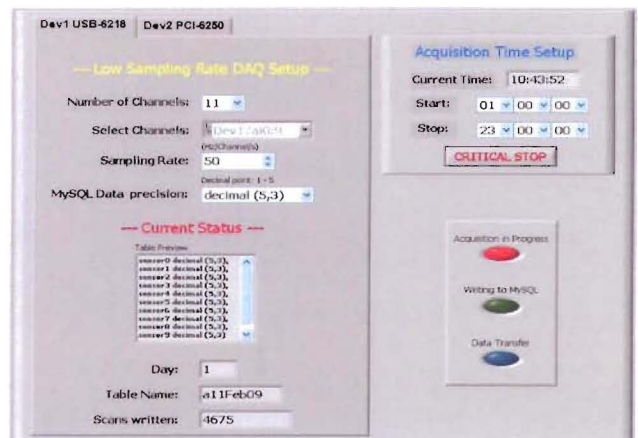

Figure 5: DAQ System User Interface

The current configuration of the data acquisition system comprises of 13 high speed channels using 20 kHz and 12 low speed channels at 50Hz and one channel at 8Hz through the serial port. After testing, in total one days worth of data acquisition from the hours 01:00 to 23:00 at these sampling rates was found to amount to roughly 40GB. Over the 1Gbps optical fiber link with a transfer speed of 7.2GB/min the 2 hour gap provides sufficient time to transfer the collected data.

VI. CONCLUSION

The DAQ system developed meets all of the requirements posed for the CM of a wind turbine. The design choices made also allow all of the performance and safety requirements requested by the industrial partner to be fulfilled. Initial system lab tests show that the DAQ system is both simple and robust in its operation where the system successfully carried out a 2 week test, error free. The system is also capable of reconfiguration allowing for future changes that may be required such as the addition or removal of certain sensors.

REFERENCES

- [1] <http://www.bwea.com/ukwed/index.asp>
- [2] Swiszczy, G., Cruden, A., Booth, C., Leithead, W., "A Data Acquisition Platform for the Development of a Wind Turbine Condition monitoring System", *International Conference on Condition monitoring and Diagnosis 2008*, pp.1358-1361
- [3] <http://www.narc.co.uk>
- [4] <http://www.redcrossfirstaidtraining.co.uk>
- [5] <http://www.mysql.com>
- [6] <http://msdn2.microsoft.com/en-us/library/aa366778.aspx>
- [7] <http://jeffreystavis.com/lost/labsql.html>