



Strathprints Institutional Repository

Clarke, Joseph Andrew and Connor, Gary and Grant, Andrew and Johnstone, Cameron and Ordonez Sanchez, Stephanie Eugenia (2009) *Contra-rotating marine current turbines : single point tethered floating system - stability and performance*. In: 8th European Wave and Tidal Energy Conference, EWTEC 2009, 2009-09-07 - 2009-09-10, Uppsala, Sweden.

Strathprints is designed to allow users to access the research output of the University of Strathclyde. Copyright © and Moral Rights for the papers on this site are retained by the individual authors and/or other copyright owners. You may not engage in further distribution of the material for any profitmaking activities or any commercial gain. You may freely distribute both the url (<http://strathprints.strath.ac.uk/>) and the content of this paper for research or study, educational, or not-for-profit purposes without prior permission or charge.

Any correspondence concerning this service should be sent to Strathprints administrator: <mailto:strathprints@strath.ac.uk>



Clarke, J.A. and Connor, G. and Grant, A.D. and Johnstone, C. and Ordonez-Sanchez, S. (2009) Contra-rotating marine current turbines: single point tethered floating system - stability and performance. In: 8th European Wave and Tidal Energy Conference, EWTEC 2009, 7-10 September 2009, Uppsala, Sweden

<http://strathprints.strath.ac.uk/8453/>

Strathprints is designed to allow users to access the research output of the University of Strathclyde. Copyright © and Moral Rights for the papers on this site are retained by the individual authors and/or other copyright owners. You may not engage in further distribution of the material for any profitmaking activities or any commercial gain. You may freely distribute both the url (<http://strathprints.strath.ac.uk>) and the content of this paper for research or study, educational, or not-for-profit purposes without prior permission or charge. You may freely distribute the url (<http://strathprints.strath.ac.uk>) of the Strathprints website.

Any correspondence concerning this service should be sent to The Strathprints Administrator: eprints@cis.strath.ac.uk

Contra-rotating Marine Current Turbines: Single Point Tethered Floating System - Stability and Performance

Joe Clarke, Gary Connor, Andrew Grant, Cameron Johnstone, Stephanie Ordonez-Sanchez¹

¹Energy Systems Research Unit,
Dept. of Mechanical Engineering,
University of Strathclyde,
Glasgow, UK
E-mail: esru@strath.ac.uk

Abstract

The Energy Systems Research Unit within the Department of Mechanical Engineering at the University of Strathclyde has developed a novel contra-rotating tidal turbine (CoRMaT). A series of tank and sea tests have led to the development and deployment of a small stand-alone next generation tidal turbine. Novel aspects of this turbine include its single point compliant mooring system, direct drive open to sea permanent magnet generator, and two contra-rotating sets of rotor blades.

The sea testing of the turbine off the west coast of Scotland in the Sound of Islay is described; the resulting stability of a single-point tethered device and power quality from the direct drive generator is reported and evaluated. It is noted that reasonably good moored turbine stability within a real tidal stream can be achieved with careful design; however even quite small instabilities have an effect on the output electrical power quality. Finally, the power take-off and delivery options for a 250kW production prototype are described and assessed.

Keywords: contra-rotating, stability, tidal, turbine.

Nomenclature

a	=	axial flow factor
C_p	=	power coefficient
C_T	=	thrust coefficient
η	=	efficiency
γ	=	yaw angle

Abbreviations

BEM	=	Blade Element Momentum
CAD	=	Computer Aided Design
CFD	=	Computational Fluid Dynamics
CoRMaT	=	Contra Rotating Marine Turbine
FFT	=	Fast Fourier Transform
IG	=	Induction Generator
IGBT	=	Insulated Gate Bipolar Transistor
MWh	=	Megawatt hour

PMG	=	Permanent Magnet Generator
PWM	=	Pulse Width Modulation
rpm	=	Revolutions per minute
SCR	=	Silicon Controlled Rectifier
TSR	=	Tip Speed Ratio
UK	=	United Kingdom

1 Introduction

A contra-rotating marine current turbine has been developed by the Energy Systems Research Unit (ESRU) at the University of Strathclyde. The concept and its realisation have been widely reported [1-2], and it is claimed that a major advantage of the contra-rotating configuration is the elimination of reactive torque. Thus it has been postulated that a neutrally buoyant turbine could be ‘flowed’ from a simple single point compliant mooring. Such an arrangement has a number of significant advantages:

- The cost of installation and recovery is significantly reduced over 1st generation pile or jacket mounted turbines.
- The device is free to yaw and align with the tidal flow (which is unlikely to be strictly bi-directional), and therefore energy capture is increased.
- Such a mooring is applicable to sites in deep water and yet still allows operation in the upper section of the water column where the tidal velocity is greater, thus maximising power output.

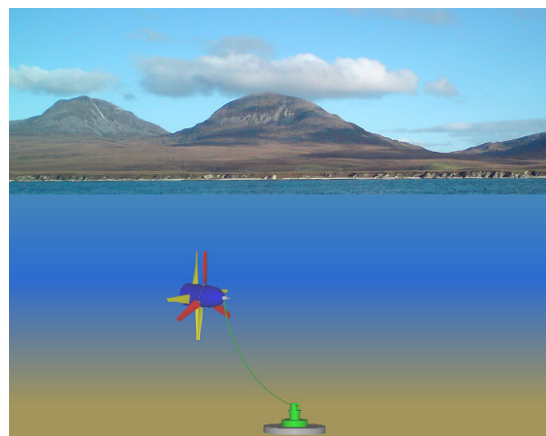

Figure 1: Mock-up of CoRMaT stand-alone system.

2 CoRMaT Development

A complete scaled tidal turbine system with single point mooring was designed and built to evaluate its performance. The 1m diameter turbine and generator were initially tested in a towing tank facility, and then by towing alongside a research vessel, before the final deployment in an energetic tidal stream in the Sound of Islay, Scotland.

This complete stand-alone system comprised a gravity foundation; a compliant mooring; a contra-rotating turbine with a direct drive, open to sea, permanent magnet generator; and a floatation buoy. The turbine generated electricity into a resistive dump load, with the electrical system acting to control the rotor speed by means of the power electronics, onboard controller and telemetry. High resolution data was logged to determine the tidal velocity, power output, rotor speeds, and the alignment and stability of the turbine and other parts of the system.



Figure 2: Photo of CoRMaT stand-alone system.

Fig. 1 illustrates the basic concept of the CoRMaT tidal system. Given the scale of the device tested, a surface buoy attached to the turbine mooring was also required, to provide transmission of telemetry data and sufficient buoyancy to prevent the turbine from striking the bottom under all conditions of operation. At larger scales, sufficient buoyancy can be provided within the turbine nacelle alone.

A pod was attached below the buoy (and hence subsea) to contain the electrical load and thus provide natural cooling in the surrounding seawater. Additionally the pod contained the power electronics (smoothing and PWM control), a single 8 channel high speed (1000Hz) stand-alone data recorder with 1GB data card, and a microprocessor to provide data processing and control functionality. Instrumentation, power and communications cables accessed the pod through IP68 cable glands backed up by a polyurethane resin back-fill. The sensors aboard the turbine itself were: Rotor1_RPM, Rotor2_RPM, Inclination_Roll, Inclination_Pitch, and Velocity_tide. The sensors contained within the pod were: PMG_Voltage,

PMG_Current, Buoy_Roll, and Buoy_Pitch. The microprocessor monitored the same data as the solid state recorder but turned it into an RS232 stream which was sent to both the data recorder (for back-up purposes) and via the surface buoy antenna as telemetry to the support vessel. Additionally a GPS logger was installed to gain tidal flow direction and device yawing information. Fig. 2 shows the system ready for deployment.

3 Sound of Islay Sea Tests

Data was recorded for all the aforementioned channels at 100Hz. The instrumentation was tested prior to deployment and again immediately after retrieval. CoRMaT operation and systems were firstly verified at a relatively benign site in the Kyles of Bute, and then the journey to Islay was undertaken.

A crucial factor was found to be the dynamic behaviour of the turbine. Significant pitch and yaw motion was apparent and this affected the accuracy of measurement of the tidal current speed. Pitch and yaw of course affects the hydrodynamic performance of the rotors, and hence the power output. Given the high sampling frequency, these unsteady influences could clearly be seen in the records of rotor speeds and generator output voltage.

Due to an approaching storm the turbine was immediately deployed on arrival off Bunnahabhainn at the Sound of Islay on the 5th of October 2008. The turbine was sited in around 12m of water at site **A** (see Fig. 3) and the tender vessel St Hilda stationed in the adjacent anchorage (to the south west). The tide was observed to be flowing at around 2.1 knots from north to south. The telemetry from the turbine observed that CoRMaT was functioning, however after a period of time no power was being generated from the system. As all instrumentation was consistent in this evaluation a dinghy was launched to check the turbine. On arrival it was found that the turbine was at the very calm centre of what appeared to be a significant eddy – a phenomenon related to the position at this particular site within the bay at Bunnahabhainn at a specific point in the tidal cycle. This experience underlines the requirement for detailed site surveys continued both upstream and downstream of the site at all stages of the tidal cycle before deployment!

Redeployment was swiftly and successfully undertaken at location **B** (see Fig. 3) in around 16m of water within a visible tidal stream. The St Hilda then stood off in the adjacent area monitoring the turbine operation until retrieval of the gravity foundation, buoys and turbine was required. The benefits of earlier practice in calm waters now showed themselves: the procedure was safely completed in a dynamic sea environment in less than 10 minutes, with retrieval of all items of equipment and a comprehensive data-set for the conditions encountered.

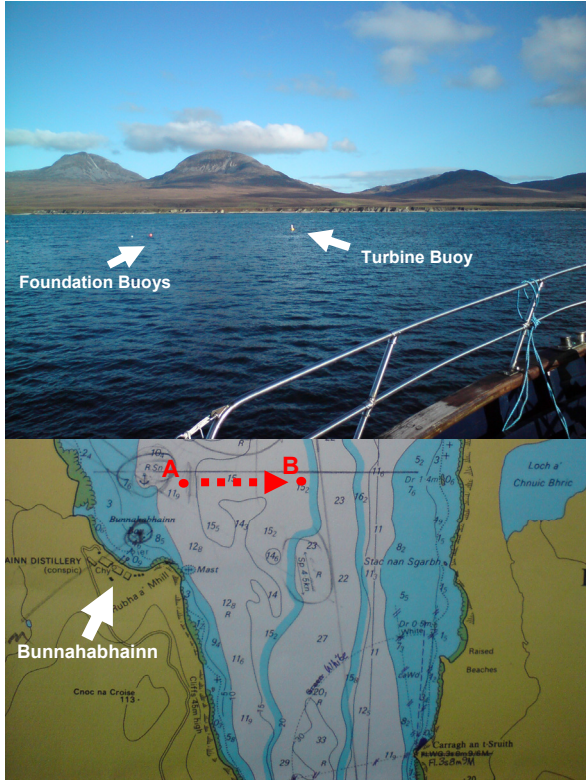

Figure 3: Sound of Islay test sites - photo is of site B.

Fig. 4 illustrates the 4 different periods of operation at Islay:

- A. Deployment at point A (Fig. 3) and gradual decline of power output as the eddy forms and uniform tidal flow diminishes.
- B. Moving to and deployment at point B (Fig. 3).
- C. Operation of CoRMaT within the Sound of Islay.
- D. Retrieval of CoRMaT onto the St Hilda.

Window C in Fig. 5 displays the resulting data under normal operating conditions for CoRMaT in the Islay tidal stream. It is notable that the voltage varies over very short periods of time. Turbulence in the stream is the likely cause (unfortunately this was not measured). For any turbine, turbulence will cause fluctuations in power output due to changes in the magnitude and direction of the stream velocity, which affect the hydrodynamic performance of the rotor blades. But for a turbine on a compliant mooring, turbulence will have a second effect: it will induce unsteady pitch and yaw motions of the turbine itself which may exacerbate the problem. Misalignment will degrade turbine energy capture proportionately to the square of the cosine of the yaw angle [3]:

$$C_P = 4a(\cos \gamma - a)^2 \quad (1)$$

The power (which is plotted negative due to the current direction) of course varies in line with voltage fluctuation. The only exception to this is the small power spike when the load on the turbine is increased using the PWM load control. A 5-point moving average power value (i.e. recorded at 20 Hz) is added to both Figures.

The recorded tidal current speed is seen to vary from just below 0.5ms^{-1} to 0.67ms^{-1} . This when related to the electrical power output (using a moving average to partially remove fluctuations) indicates that this non-optimised device produces C_p values of between 0.21 and 0.28. This is in line with predictions made at the design stage [4]; in terms of hydrodynamic performance this turbine is far from optimal, incorporating as it does a number of components from previous test programmes.

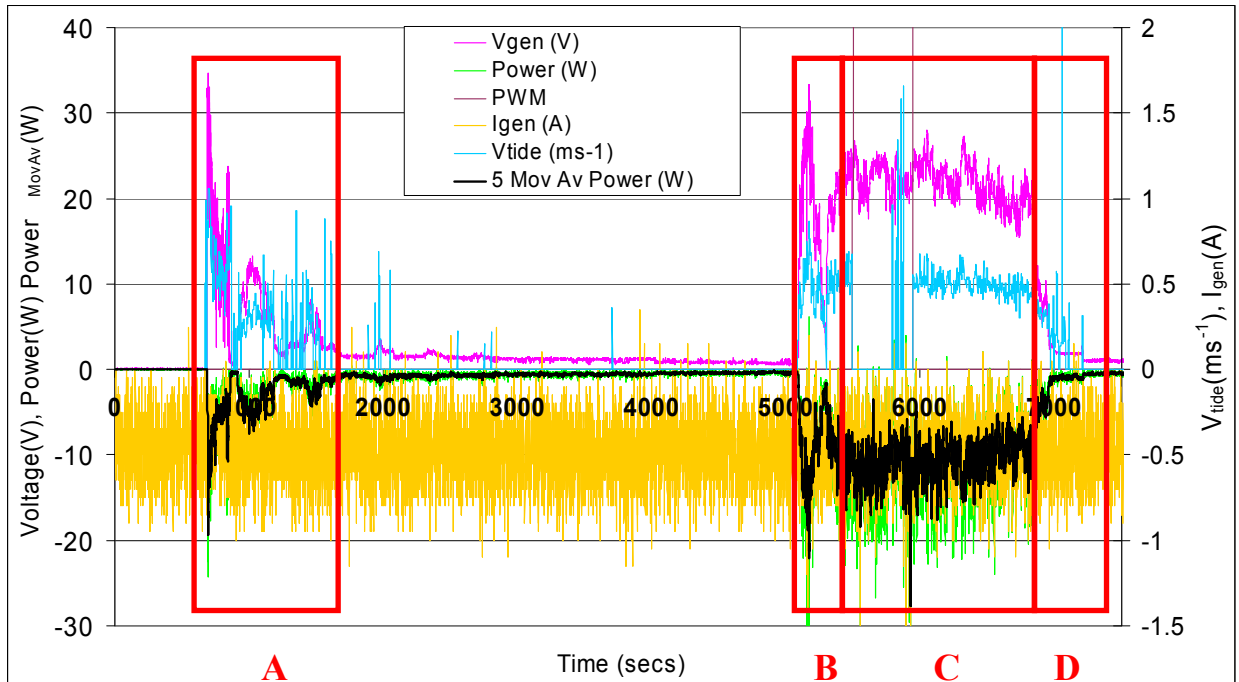

Figure 4: CoRMaT operational overview at Sound of Islay

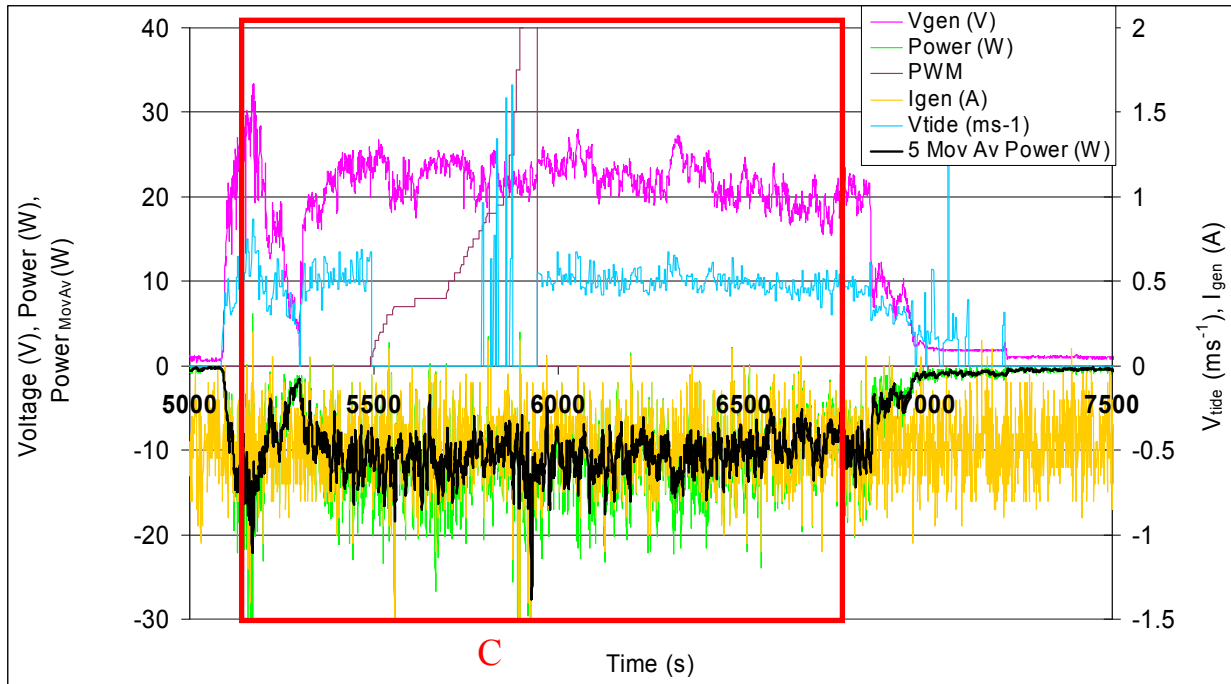

Figure 5: CoRMaT operation at Sound of Islay test site.

4 Stability of a Moored Device

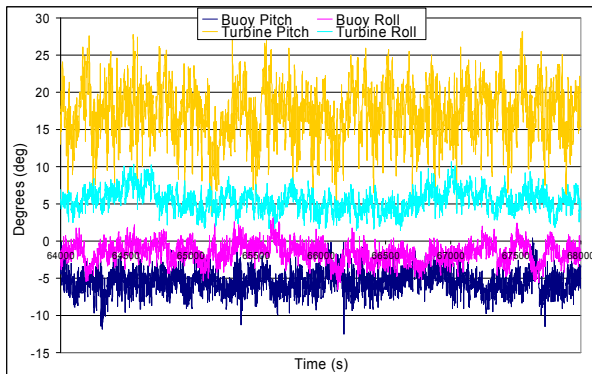

Figure 6: Example of turbine and surface buoy inclinometer data.

The high frequency dynamic turbine and mooring inclinometer data (Fig. 6) must be viewed in the light of the non-optimal turbine geometry (hub-to-tip ratio was approximately 0.47), but they provided the following key results:

- Increased thrust loading on the turbine results in greatly increased dynamic stability.
- Stability in a ‘non-turbulent’ tidal stream (Kyle of Bute) is good and only very small dynamic fluctuations are noted.
- Operation in a turbulent, wave affected tidal stream (Islay) introduces dynamic instabilities and fatigue: although within design limits. The surface piercing buoy will be a critical parameter in this.

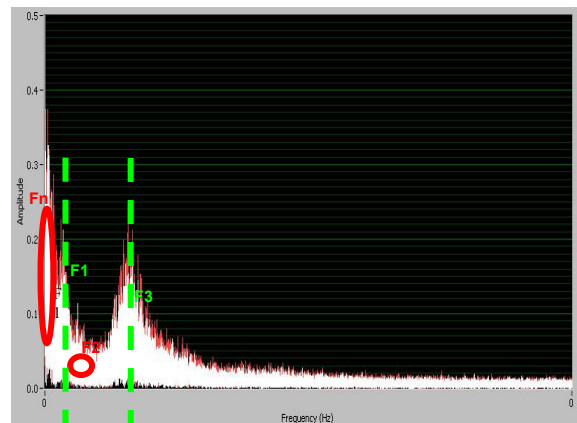

Figure 7: FFTs of CoRMaT pitch data showing the dominant frequencies at Islay.

Pitch	F _n	F ₁	F ₂	F ₃
Hz	0.597	1.792	3.885	8.167
Source	Oversize nacelle	Fundamental rotor 1 speed	Combined rotor speed	Karman vortex shedding

Table 1: Dominant CoRMaT pitching frequencies.

Fig. 7 displays and Table 1 lists the dominant CoRMaT pitching frequencies during a sample 30 minute period of testing in the tidal stream through the Sound of Islay. As expected some small rotor dynamic frequencies are observed (F₁ and F₂) due to slight blade misalignments in the test rig set-up, however frequencies F_n and F₃ are of an amplitude that would require system modification. F_n is the dynamic instability present due to the non-ideal size of the nacelle relative to blade length, necessitated by the re-use of existing components during testing. It should be

possible to use a proportionally smaller nacelle as the device is scaled up and this mode would then greatly diminish. F3 was found to be due to vortex shedding behind the vertical tubular section connecting the turbine to the surface buoy, which again should not be present in a larger version as the strut blockage area relative to the rotor area would be scaled down significantly.

Fig. 8 displays the dominant CoRMaT roll frequencies during the same sample 30 minute period of testing covered by Fig. 7. Frequency F1 is again observed, and F4 at five times F1. The presence of F4 is hard to explain, but it is barely discernible. Non-uniform aspects of the ‘homebuilt’ axial flux generator produce the very small frequencies of F5 and F6. These can be reduced by the precision manufacturing of the PMG as would be expected during full-scale industrial manufacture.

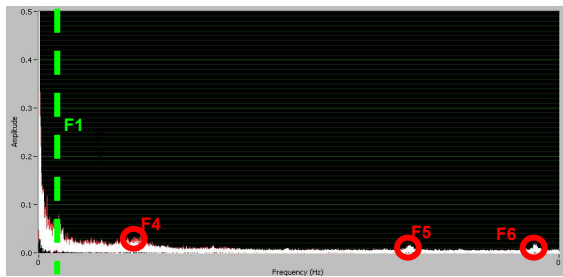

Figure 8: FFTs of CoRMaT roll data showing the dominant frequencies at Islay.

Roll	F1	F4	F5	F6
Hz	1.859	9.362	35.657	47.742
Source	Fundamental rotor 1 speed	5*F1	PMG stator non uniformities (9*F2)	Blade-blade interactions (12*F2)

Table 2: Dominant CoRMaT rolling frequencies.

The contra-rotating permanent magnet generator allowed torque balancing magnetically across its ‘air-gap’. This proved to work well with reactive torque neutralised to a very high degree as evidenced by the stable and constant roll angle of the device during all modes of operation.

5 Electrical Generator

The relatively slow prime mover rotational speed of a tidal turbine generally necessitates a gearbox to increase the speed suitably for a common four-pole generator. Another option is a direct drive generator with a large number of poles. This has the distinct advantages of:

- a higher overall power take off efficiency of typically 90% near rated load [5], compared to around 85% for a costly multi-stage high torque gearbox (4-stage efficiency of 94%) and generator (90%) combination [6];

- greater reliability;
- a diminished maintenance requirement.

The manufactured direct drive generator has an axial magnetic field created by 24 Neodymium-Iron-Boron (Nd-Fe-B) N50 grade permanent magnets distributed on the 2 rotors making up 12 magnetic poles, and sandwiching the stator which contains 9 copper windings. Nd-Fe-B magnets have vastly superior magnetic properties over traditional Ferrite magnets. The remanence flux density B_r of the chosen magnets is 1.42T. The maximum operating temperature (150 °C) of Nd-Fe-B magnets is unlikely to be an issue in a submerged tidal generator. Figure 9 is a CAD drawing of the generator showing the critical components.

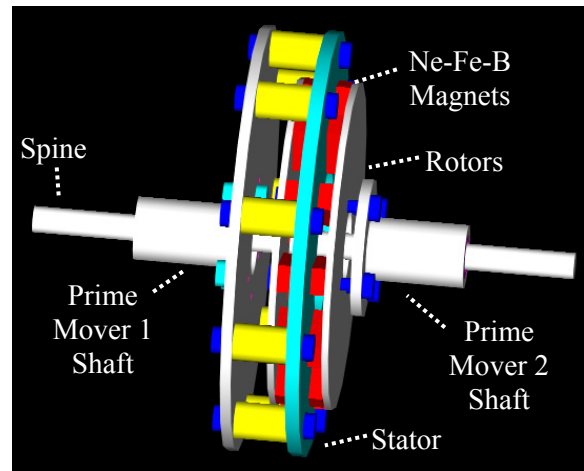

Figure 9: CAD rendering of contra-rotating axial flux generator.

The axial-flux generator is configured to provide a 3-phase electrical output. This is converted to DC via a 3-phase rectifier. The energy may therefore be efficiently transmitted underwater and inverted at the grid end, or in this experimental case, fed into a resistive dumped load by a Pulse Width Modulated (PWM) driven Insulated Gate Bipolar Transistor (IGBT) allowing the turbine microcontroller to regulate the overall turbine speed and attain maximum C_p throughout the tidal cycle. The contra-rotating prime mover torque balance critical to maintaining the zero reactive torque and thus providing turbine hydrodynamic stability is provided inherently by the magnetic flux linkage across the stator-rotor air gap.

In addition it was decided to experiment with a submersible generator, that is, the rotors and stator both operate in sea-water. Although the magnetic properties of sea-water and air are not significantly different, the electrical insulating properties and corrosive abilities are. The rotors and nickel coated permanent magnets are therefore coated in a hard wearing polymer to provide corrosion protection. The stator is constructed from polyurethane resin into which the copper coils are hermetically sealed with glands allowing the electrical output cables to exit the generator. The advantages of such a generator are:

- ease of construction;
- generator/nacelle casing leaks are non issues;
- cooling is naturally provided;
- no complex sealing requirements;
- no large diameter seal friction.

The Islay sea trials proved the workability of such a generator which performed efficiently without any issues throughout the trials both in sea water and fresh water.

6 250kW Production Prototype Power Take-off Options

Following the scaled stand-alone CoRMaT sea trials, engineering analysis and design was undertaken for a large commercial prototype with a power output rating of 250kW. Previous CoRMaT scaled test-bed versions have utilised either simple friction braking and heat dissipation, or a direct drive permanent magnet electrical generator with resistive dumped load heat dissipation. The production versions would however be required to produce grid compliant electricity at lowest cost and with highest reliability.

Parameter	Value	Unit
Generator Rated Power	250	kW
Maximum Springs Tidal Velocity	2.5	ms ⁻¹
Rotor Diameter	10	m
Maximum nacelle diameter	2	m
Front rotor blades (no.)	3	
Rear rotor blades (no.)	4	
Combined design TSR	7	
Transmission voltage	33	kV

Table 3: Parameters for Prototype CoRMaT Tidal Turbine

The turbine design parameters are summarised in Table 3. A number of options are available to achieve these ends and a number of factors must be borne in mind.

Turbulence, Drive Train and Power Quality

As shown previously any tidal device's power train components are likely to be subject to highly irregular torque loading due to the same turbulent conditions as observed during the sea trials reported here. As with wind turbines, this will lead to wear on the mechanical parts (especially gearbox bearings and gear teeth) and produce failure rates greater than perhaps expected.

With regard to gearbox failure, Swedish wind turbine statistics [7] reveal that although turbines have greater than 98% availability in any year, and although there are components more likely to fail (electrical system and blades), the failed component that produces highest overall downtime is the gearbox. This is likely due to their large and cumbersome nature requiring specialist equipment for replacement, and the fact that

entire rebuilds may be required around the failed gearbox component. Downtime is likely to be highly exacerbated in the offshore marine environment.

The Swedish statistics also reveal that over the period 2000 – 2004 the average number of gearbox failures per turbine per year was 0.045. Therefore over a 15-20 year turbine lifetime a turbine is extremely likely to suffer a gearbox fault or failure. It should also be noted that some particular turbine types have failure rates significantly higher than the average; therefore if a gearbox is to be adopted in a tidal system, good (over)design is absolutely critical.

The power output test-data from the Islay sea trials would suggest that turbulence and tethered next generation turbine pitching variance leads to fluctuating power output which would also be unacceptable for direct electricity grid connection: particularly to weak rural grids. It therefore appears that there is little choice but to provide power electronics to condition the output suitably.

Fixed Pitch Rotor Blades

In order to simplify operation and increase reliability, fixed pitch rotor blades have been selected for CoRMaT. Studies [8] have concluded that pitching blade energy production performance ranges from providing up to 7% more power than its fixed pitch counterpart to 1% less when reliability and availability are taken into account. The capital costs of a pitching blade are also significantly higher than a fixed pitch version. To gain good efficiency from a fixed pitch rotor it is necessary that the TSR and hence rotor rotational speed can be varied. A variable speed turbine would typically yield 20-30% more energy than a fixed speed turbine. The fairly wide range of rotor speed and thus electrical frequency implies that the generator is unlikely to be directly grid connected. Therefore all generation options will again require power electronic converters to provide grid compliant electricity.

Contra-Rotating Rotors

CoRMaT embodies 2 contra-rotating sets of rotors. The increase in the number of rotors is for the sake of reducing the overall cost associated with the absorption of reactive torque. The torque must however be allowed to balance: either naturally (passively) somewhere within the drive system, i.e. by means of a differential gearing system or across the magnetic air-gap of the generator; or by means of carefully controlling the individual rotors separately.

It should be noted that variable-pitch blades are already appearing on certain full-scale demonstration tidal turbines, but are essential to provide acceptable performance in bi-directional flows. The free-yawing CoRMaT design has no need of this feature.

Rotor Blades Speed of Rotation

As the swept area of the rotor increases to provide the necessary levels of power output for cost-effective deployment, the rpm decreases (approximately an inverse square relationship with radius). TSR can not be significantly increased if cavitation and loading problems are not to be encountered. Therefore a large CoRMaT turbine (>500kW) will have a shaft speed of less than 15rpm on each rotor. The low rotational speed therefore requires gearing by mechanical (gearbox) or electrical means (generator poles) to provide sufficient voltage and frequency to maintain reasonable system integrity. The key points of this may be summarised as:

- Voltage is increased by higher rpm - thereby reducing the current and I^2R copper losses in the windings.
- Frequency is increased by higher rpm – this reduces generator and power electronic frequency related losses.

A mechanical gearbox could be employed for a standard 4 pole 1500rpm generator – a three stage option being the most cost-effective solution (2-stage 1:64 ratio maximum, 3-stage 1:512 ratio maximum), although this would introduce an additional system component with efficiency of around 95%. The gearbox ratio may be minimised by an increased number of generator electrical poles - although this may require bespoke machine design for very low rotational speeds.

Contribution to Faults

Unlike Induction Generators (IGs), Permanent Magnet (PMGs) generators do not require energisation from the grid. They can therefore supply large (3x) full-load fault currents into the system for significant periods should they become disconnected from the grid or a fault take place. The generator windings and protection therefore require over-specification for such a circumstance, and hence the capital cost is increased.

Weight of Generator

Although improved magnetic materials have reduced the weight of PMGs, they are still significantly heavier than their IG plus gearbox counterparts. This is to some extent negated by the supporting force (buoyancy) available from the surrounding water.

Overall System Efficiency

A PMG is more efficient than an equivalent rated IG as there are no field winding losses (accounting for 20-30% of all wound IG losses). Additionally the higher efficiency due to reduced winding (heating) losses reduces the cooling requirement for a PMG. This coupled with a simpler more robust solution provides for a lower maintenance demand and maximum reliability.

Component	η (%)
Permanent Magnet Generator (PMG)	98
Induction Generator (IG)	94
3-stage gearbox	95
Rectifier (SCR)	95
Inverter Bridge and harmonic filters	95
Drive Combination	
Direct drive PMG	88
PMG and 3-stage gearbox	84
IG and 3-stage gearbox	81

Table 4: Efficiency of Power-train Options for Prototype CoRMaT

Table 4 illustrates the likely efficiencies of the possible generation topologies. It is clear that the most efficient is a direct drive PMG and this can be used as a benchmark against which to judge the economic performance of the other options, specifically with regard to the increased direct drive PMG costs weighed against the additional energy output and reliability. For example, at the current UK ROC price and with the proposed 2 times ROC multiplier, marine energy is likely to attract at least £100/MWh [9], which equates to an income difference of $(340 - 202) * 100 = £13800$ per annum between a direct drive 500kW PMG and 500kW gearbox/IG combination. Obviously, other additional significant cost savings will be forthcoming should this improved reliability lead to fewer device interventions.

Summary of Power Take-off Options

The power take-off options as previously deemed suitable for a 250kW CoRMaT prototype are summarised in Fig. 10.

Option A – utilises separate power take-off systems for each rotor; the torque balancing must therefore be undertaken utilising external sensors and a control loop. Specifically this is likely to involve field excitation control for a wound induction generator to modulate the speed and hence torque, or in the case of a permanent magnet machine full converter/rectifier current control. Additionally smaller off-the-shelf high speed generators (IG or PMG) may be utilised with adapted standard gearbox designs.

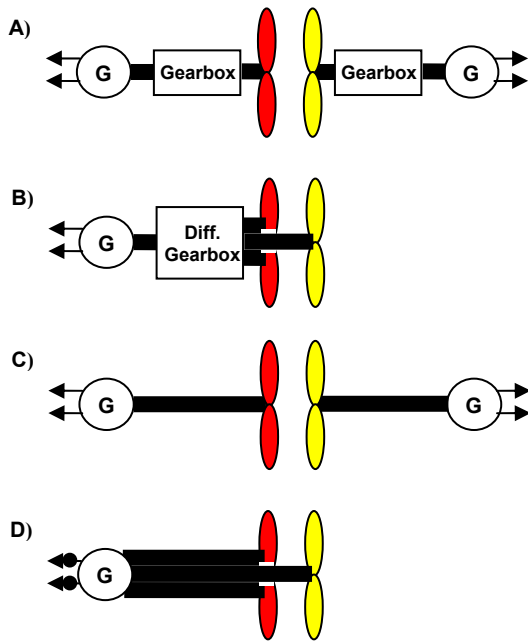

Figure 10: Power Take-off Options

Option B – utilises a single generator (IG or PMG) and a single epicyclic differential gearbox where the central sun-wheel is connected to the front rotor and the annulus ring is connected to the rear rotor. The output shaft from the gearbox is connected to the generator as normal, however it is noted that this would then become the gearbox structural support – putting very great stresses on that shaft. This gearbox would therefore be of a new specialised and bespoke design.

Option C – utilises 2 directly driven generators (PMG or IG). The torque balancing must therefore again be undertaken utilising external sensors and a control loop.

Option D - utilises a single direct drive generator (IG or PMG) and balances the torque across the generator magnetic air-gap. This option requires some means by which the electrical power from the rotating generator may be transferred to the stationary cables – normally a set of electrical slip rings.

Option	Reactive Torque Control	Complex	Cost	Reliability
A: IG	Active	Medium	Low	Medium
A: PMG	Active	Medium	Medium	Medium
B: IG	Passive	High	High	Medium
B: PMG	Passive	High	High	Medium
C: IG	Active	Low	Medium	High
C: PMG	Active	Low	Medium	High
D: IG	Passive	Medium	High	Low - Medium
D: PMG	Passive	Medium	High	Low - Medium

Table 5: Summary of Drive-train Options for Prototype CoRMaT

Table 5 attempts to summarise the basic parameters for both IGs and PMGs in order to make an engineering analysis decision for power train topology. Specific costings would require exploration, although for the more bespoke contra-rotating generator or differential gearbox these costings would require a significant amount of engineering design before costs could be defined with accuracy.

Due to the very high cost of intervention at sea, and the duration of downtime likely when waiting for suitable recovery weather windows, reliability is of the utmost concern. A bespoke sub-sea slip-ring for CoRMaT was specifically designed by experts in this area. Not only do such components add very significantly to capital costs, but the standard design life of 5 million cycles means a replacement every 1.6 years should a failure not occur beforehand (probability of 22/1342 over a four year period). Option D is therefore not currently an acceptably reliable or cost effective option.

As previously discussed even well-designed and mass produced gearboxes have high levels of failure in wind turbines and contribute very significantly to costs. A large wind turbine gearbox rebuild is likely to cost in the region of £50,000, even without the costs of the lost revenue during device downtime. A bespoke new gearbox design is very likely to suffer from reliability and ‘teething’ problems, and therefore Option B might also be considered less than ideal.

The economy of scale of a single larger generator over 2 smaller generators would be easily negated by the increased costs of the complex gearbox or slip-ring systems. Therefore Options A and C are not disadvantaged by having 2 sets of generators.

Abandoning Options B and D removes the attractive option of passive reaction torque balancing, however it should be noted that all options (A-D) would require full power conversion and control due to the aforementioned characteristics associated with a fixed pitch rotor blade design and rotor torque fluctuations. The elements for active rotor speed and thus torque (balancing) control therefore already exist within each system and add no additional cost.

The choice is therefore between Options A and C: the evaluation trade-off being between the reduced reliability and efficiency of a geared system – and the size (stator diameter) and low frequency of generation induced losses for a direct drive system. The design limit for the nacelle has been set to 2m (i.e. around 20% of rotor diameter) and it would be expected that the maximum radius for a generator would therefore be 1.8m. At a nominal rotational speed of around 15rpm to produce a frequency of 10Hz, the number of pole pairs required would be 40. As no standard IG is likely to exist at the power levels with this number of poles, and they are generally less efficient, the option of a

PMG becomes very attractive. Equation 1 may be rearranged to provide an estimation of generator radius: where J is the conductor maximum current density, r_i is the inner core radius, r_o is the outer core radius, B is the average flux density in the winding, n is the rotational speed, and a is the winding axial thickness.

$$P = 4\pi^2 J r_i B n a (r_o^2 - r_i^2) \quad (2)$$

r_o was set to be $\sqrt[3]{3} r_i$ thus optimising the power for a given outside diameter and loading. For a 500kW machine with $B_{av} = 0.4T$, $n = 15\text{rpm}$, $J_{max} = 3,000,000 \text{ A/m}^2$, $a = 0.1\text{m}$ and adding an extra 30% to the diameter for the support structure we may deduce the outer PMG diameter to be around 1.5m - well within the available nacelle diameter.

Thus the most efficient and reliable Option C, the dual direct drive PMGs would seem to be the option for which a full initial electro-mechanical design and costing should be undertaken. Full consideration of increased fault currents of a PMG should also be included in the design work.

Summary of Electrical System Options

In addition to the chosen power take-off topology, the electrical system must deliver the power from the generator to the grid. The electrical system options for more than one CoRMaT are outlined in Table 6.

As it is relatively unknown how tidal farms are likely to operate, it cannot be guaranteed that each turbine will operate at similar speeds during any period – therefore the most economic system allowing independent turbine operation should be chosen. This is the first option in the table; the active DC link.

7 Further Work

The work on CoRMaT continues with development in a number of specific areas:

- Further testing of CoRMaT and refinement of its systems in a tidal stream over an extended period of 8 months.
- Full component and system design work for a production prototype.
- Further flume and tow-tank tests with respect to optimising the stability and dynamic properties of moored and freely ‘flying’ turbines.
- Continued analysis and testing programme for rotor blade materials to provide structural integrity and resistance to the harsh marine environment.

System	Description	Comments
Active DC Link	Each CoRMaT variable frequency electrical output is rectified within the nacelle to 3.3kV DC - output to a common farm DC link – inverted to grid quality AC at the shore by a network bridge converter.	Most economic option allowing independent operation of all CoRMaTs in a farm.
Multiple CoRMaTs to a Single AC:AC Converter	Each CoRMaT generator outputs to a common synchronised AC bus and cable link – converted to grid quality AC at the shore and transformed to grid voltage levels.	Assumes that all farm IGS produce similar frequency output (i.e. rotate at similar speeds). Lowest cost.
All CoRMaTs have own AC:AC Converters	Each CoRMaT generator outputs via its own AC:AC converter to a common grid-quality AC bus – transformed to grid voltage levels at the shore.	Allows independent turbine operation but is costly.

Table 6: Electrical System Options

8 Conclusions

The stability of a single point compliantly moored tidal turbine has been investigated, and a complete system has been successfully trialled at sea. It may be concluded that it is possible to achieve acceptable dynamic stability of such a device in a tidal stream, although further investigations into the effects of turbulence and surface wave interaction are required.

Performance measurements in an energetic tidal stream (Sound of Islay) indicted significant pitch motion and rapid fluctuations in electrical power output. The principal pitch and roll frequencies have been extracted from the data and their causes identified: all can be substantially reduced by modifications to the system design. The contra-rotating generator was found to be very effective in minimising reactive torque from the turbine.

The qualitative analysis of CoRMaT power take off and conversion options for the current time concludes that the most reliable, efficient and hence cost effective option is likely to be 2 directly driven bespoke PMGs with full onboard variable speed/torque control and rectification for each rotor of each device. A farm of such devices would be linked to the grid via a DC link and fed into the onshore National Grid by use of a shore based AC converter system.

The contra-rotating turbine thus possesses a number of unique features that make it very attractive as a reliable and cost-effective next generation buoyant tidal generator. The basic concepts have been proven and a pre-production prototype of 250kW capacity is now proposed.

References

- [1] J.A. Clarke, G Connor, A D Grant and C M Johnstone, 'Design and testing of a contra-rotating tidal current turbine', IMech E Journal of Power and Energy Special Edition on Tidal Energy, May 2007, UK.
- [2] J. A. Clarke, G. Connor, A. D. Grant, C. M. Johnstone and D. Mackenzie: Design and initial testing of a contra-rotating tidal current turbine. Proceedings of the World Renewable Energy Congress 2006, Florence, Italy, 2006.
- [3] W.M.J. Batten, A.S. Bahaj, A.F. Molland, J.R. Chaplin: Power and Thrust Measurements of Marine Current Turbines under various Hydrodynamic Flow Conditions in a Cavitation Tunnel and Towing Tank. Renewable Energy 32 (3), pp 407-426. Elsevier 2007.
- [4] Clarke J, Connor G, Grant A, Johnstone C, Ordonez-Sanchez S. A Contra-rotating Marine Current Turbine on a Flexible Mooring: Development of a Scaled Prototype. 2nd International Conference on Ocean Energy, Brest, France, October 2008.
- [5] Nilsson K, Segergren E, Sundberg J, Sjostedt E, Leijon M.: Converting Kinetic Energy in Small Watercourses Using Direct Drive Generators. Proceedings of OMAE04 23rd International Conference on Offshore Mechanics and Arctic Engineering (2004), Vancouver, British Columbia, Canada. 2004.
- [6] J.A. Cotrell: Preliminary Evaluation of a Multiple-Generator Drivetrain Configuration for Wind Turbines, 21st American Society of Mechanical Engineers (ASME) Wind Energy Symposium, Reno, Nevada, January, 2002.
- [7] J. Ribrant, L.M. Bertling: Survey of Failures in Wind Power Systems With Focus on Swedish Wind Power Plants During 1997-2005, IEEE Transactions on Energy Conversion. Vol. 22, no. 1, March 2007.
- [8] Alstom Power Ltd, WUMTUA, and LOG+1 Ltd for the DTI: Economic Viability of a Simple Tidal Stream Energy Capture Device, URN Number: 07/575. 2007.
- [9] UK DTI, May 2005: Marine Renewables Wave and Tidal-stream Energy Demonstration Scheme. www.dti.gov.uk/files/file23963.pdf 2005.