



## Strathprints Institutional Repository

Strachan, S.M. and West, G.M. and McDonald, J.R. and Duffy, A.H.B. and Farrell, Jim and Gwyn, B. (2001) *Knowledge, management and intelligent decision support for protection scheme design and application in electrical power systems*. In: Proceedings of the 7th International conference on developments in power system protection. IEEE, pp. 559-562. ISBN 0-85296-732-2

Strathprints is designed to allow users to access the research output of the University of Strathclyde. Copyright © and Moral Rights for the papers on this site are retained by the individual authors and/or other copyright owners. You may not engage in further distribution of the material for any profitmaking activities or any commercial gain. You may freely distribute both the url (<http://strathprints.strath.ac.uk/>) and the content of this paper for research or study, educational, or not-for-profit purposes without prior permission or charge.

Any correspondence concerning this service should be sent to Strathprints administrator: <mailto:strathprints@strath.ac.uk>



Strachan, S.M and West, G.M and McDonald, J.R and Duffy, A.H.B and Farrell, J and Gwyn, B (2001) Knowledge, management and intelligent decision support for protection scheme design and application in electrical power systems. In: Proceedings of the 7th International conference on developments in power system protection. IEEE, pp. 559-562. ISBN 0-85296-732-2

<http://eprints.cdlr.strath.ac.uk/6412/>

This is an author-produced version of a paper published in Proceedings of the 7th International conference on developments in power system protection. IEEE, pp. 559-562. ISBN 0-85296-732-2.

Strathprints is designed to allow users to access the research output of the University of Strathclyde. Copyright © and Moral Rights for the papers on this site are retained by the individual authors and/or other copyright owners. You may not engage in further distribution of the material for any profitmaking activities or any commercial gain. You may freely distribute both the url (<http://eprints.cdlr.strath.ac.uk>) and the content of this paper for research or study, educational, or not-for-profit purposes without prior permission or charge. You may freely distribute the url (<http://eprints.cdlr.strath.ac.uk>) of the Strathprints website.

---

Any correspondence concerning this service should be sent to The Strathprints Administrator: [eprints@cis.strath.ac.uk](mailto:eprints@cis.strath.ac.uk)

# KNOWLEDGE MANAGEMENT AND INTELLIGENT DECISION SUPPORT FOR PROTECTION SCHEME DESIGN AND APPLICATION IN ELECTRICAL POWER SYSTEMS

S.M. Strachan  
Centre for Electrical  
Power Engineering,  
University of  
Strathclyde,  
UK

G.M. West  
Centre for  
Electrical Power  
Engineering,  
University of  
Strathclyde,  
UK

Prof. J.R.  
McDonald  
Centre for  
Electrical Power  
Engineering,  
University of  
Strathclyde,  
UK

Dr. A.H.B.  
Duffy  
CAD Centre,  
DMEM,  
University of  
Strathclyde,  
UK

J. Farrell  
ScottishPower,  
UK

B. Gwyn  
National Grid,  
UK

## ABSTRACT

The paper describes a research project carried out in conjunction with two major UK utilities, focusing on the introduction of knowledge management and intelligent decision support to the existing protection design and application processes operated within both companies. A brief overview is provided of the generic design process, and the development of the web-based Design Engineering Knowledge Application System (DEKAS). This system incorporates intelligent case-based reasoning (CBR) functionality to address the knowledge management and decision support requirements of each company's design process. The perceived key benefits of DEKAS relating to the management and utilisation of the data, information and knowledge throughout the protection design process is also discussed.

## INTRODUCTION

The task of designing a protection scheme for a transmission network is a complex one, involving the consideration of multiple constraints and interfacing with other disciplines such as primary plant design. Traditionally, this process relies upon the knowledge and experience of utility protection engineers. When designing a protection scheme, the engineer will often refer back to similar projects in which they have been involved. This experience combined with the relevant company documentation, systems information and other supporting data and information resources, enables experts to design suitable protection schemes for sanctioned changes to the system infrastructure.

DEKAS offers engineering support during the protection design and application process. The system provides a global, graphical representation of the overall process through the application of web technology. The relationships between the individual activities, which collectively constitute the protection design process, have been defined in terms of their data and information flows and represented through models based on the KADS modelling methodology, Wielinga et al (1).

DEKAS provides a gateway to a single 'virtual source' of information and data through its integration with existing company repositories and resources. This provides design engineers with access to *the right data, information and ultimately knowledge at the right time* throughout the duration of a protection design project.

Having identified *what, where* and *when* information and data is utilised within the overall protection design and application process, the focus of the research concentrated on *how* better use could be derived from existing data and information sources. Knowledge may then be leveraged as an important resource within this process, Schreiber et al (2). This led to the development of an intelligent decision support facility within DEKAS.

The underlying approach adopted by engineers during protection scheme design has been realised through discussions with experts in this area. Typically, protection scheme design may involve the re-use of knowledge relating to previous, similar design projects. Automatic selection of the most appropriate design project from which knowledge may be re-used can be achieved through the application of CBR techniques, Watson (3).

## OVERVIEW OF THE GENERIC DESIGN PROCESS

Following the detailed examination of the design processes operated within each organisation, a generic, six stage design process was derived. The high level protection design process consists of the following stages:

- ?? Feasibility
- ?? Specification
- ?? Contract Award
- ?? Design Conformance Checks
- ?? Technical Data
- ?? Commissioning

## REPRESENTATION OF THE PROTECTION DESIGN PROCESS USING KADS

Each stage of the protection design process can be described in terms of the activities involved and their associated data and information requirements. Through a series of knowledge elicitation sessions the roles of key individuals within the design process were captured and defined, Firlej et al (4). The role of a design expert can be described in terms of the activities performed to achieve a set of predefined objectives associated with a particular stage of the protection design process. In addition, the knowledge resources associated with each activity were also identified.

Following the capture of this design process knowledge, it could then be represented graphically using the KADS modelling methodology (1). Modelling this process knowledge via the inter-related 'task' and 'inference' layers of the KADS methodology (Fig. 1) illustrated the interaction between individual activities and the data, and information flows between them.

The task layer is constructed from a series of task knowledge models depicting the hierarchical relationship between individual activities (tasks) and sub-activities (sub-tasks) involved in the completion of each stage of the protection design process. The inference layer is constructed from a series of inference knowledge models, each one focusing on a particular activity (task), describing its objective in terms of the expected output from the activity and the project specific and generic reference inputs required to perform the activity and produce the required output.

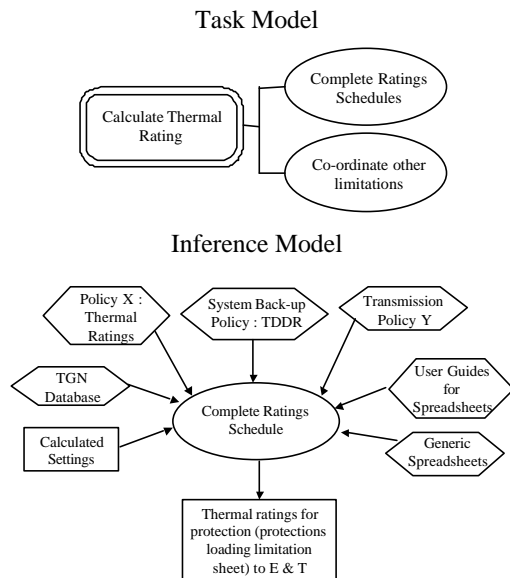

Figure 1: Task and Inference Knowledge Models

**DEVELOPMENT OF DEKAS**

**Representation of the Knowledge Models within the DEKAS Web Environment**

The knowledge models generated from the knowledge elicitation sessions, have been incorporated within DEKAS. This offers the protection design engineer a global view of the complete design process, enabling navigation through the modelled process as the design project progresses (Fig. 2).

**Document Storage, Retrieval and Administration Functionality**

In addition to guiding design engineers through the design process, DEKAS also provides a gateway to accessing all documentation and data relevant to a particular design activity

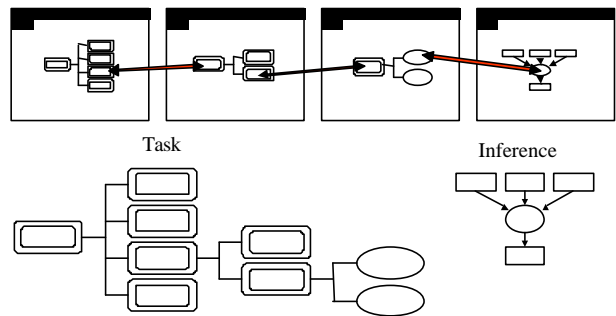

Figure 2: Navigation through the Modelled Process

Protection engineers are effectively provided with access to the right information and data at the right time. This is achieved through the integration of DEKAS with existing company data and information repositories (Fig. 3) and the provision of dynamically created system links. Each link is associated with the project specific inputs, reference inputs and outputs of each inference knowledge model represented with DEKAS (Fig. 4). Engineers can subsequently retrieve information relevant to the current stage of the design.

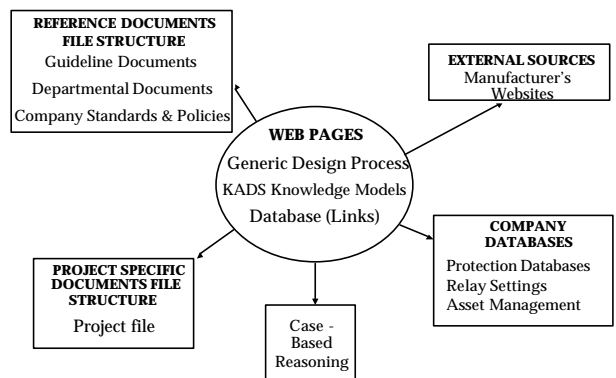

Figure 3: DEKAS Integration with Existing Company Repositories

To enable DEKAS to be used within a working environment it is essential that the creation, updating and modification of all design documentation, through the use of DEKAS, is managed appropriately. Consequently, DEKAS incorporates a provision for document management, by maintaining an auditable

trail of the design cycle associated with each design project or providing a link to a proprietary document management system.

**Re-Use of Knowledge Associated with Similar Designs using Case-Based Reasoning**

Case-based reasoning can be described by the “four-RE” process (3):

- ?? RETRIEVE the most similar case(s).
- ?? REUSE the information and knowledge to solve the ‘problem’.
- ?? REVISE the proposed ‘solution’.
- ?? RETAIN the parts of the experience likely to be useful for future ‘problem’ solving.

Existing company design documentation, associated with completed protection scheme designs, contain valuable information relating to the nature of the design project and specifically the problems encountered, solutions derived and the ensuing lessons learned. Incorporating CBR functionality within DEKAS is intended to harness and exploit this knowledge as a valuable resource for future designs.

At present the retrieval, reuse, revision and retention of knowledge associated with similar protection scheme designs is the responsibility of, and mostly restricted to, the individual tasked with the design. While advice may be elicited from other experienced individuals as and when required, the approach to the company-wide retention and dissemination of tacit (experiential) knowledge remains unstructured and informal. By defining a representative case structure of a ‘typical’ protection scheme design, CBR techniques can identify similar completed designs, forming the basis for new ones. This application of CBR effectively emulates and formalises the intuitive reasoning process currently adopted by protection design engineers during the design of a protection scheme.

Following the identification of similar protection scheme designs of the past, via this CBR functionality, it is necessary to identify and return the relevant area of the design suitable for re-use. This is dependent upon the activity currently being performed by the engineer, and is indicated by the engineer’s progress through the modelled design process represented within the DEKAS web environment. Therefore, it is the combination of the CBR functionality and modelled design process, both featured within DEKAS, which enables the engineer to retrieve all relevant documentation from an archived design project. This facilitates a fast, accurate and consistent approach to the design of a new protection scheme.

**Example of the Use of DEKAS in Performing the Protection Settings Activity.**

The protection setting activity resides within the Technical Data stage of a design project (Fig. 4). As the design progresses, DEKAS will naturally guide the engineer towards the protection ‘settings’ activity. This activity requires the engineer to perform protection setting calculations using a standard pro-forma document. The knowledge model provides a breakdown of the ‘settings’ task into three sub-tasks. Each sub-task has an inference model associated with it, providing the engineer with direct and easy access to all resources required for the successful completion the ‘settings’ task. These resources include equipment/line data, relevant company standards and fault studies and can be accessed via an ‘information’ layer detailing why a particular resource is required and which areas/sections are of particular relevance and importance to the task. A direct link to the output of the task is also available from this ‘information’ page. In addition to completing the ‘settings’ calculations, the engineer may perform a sanity check of the calculated settings by comparing them with those associated with similar, previous designs retrieved using the DEKAS CBR feature.

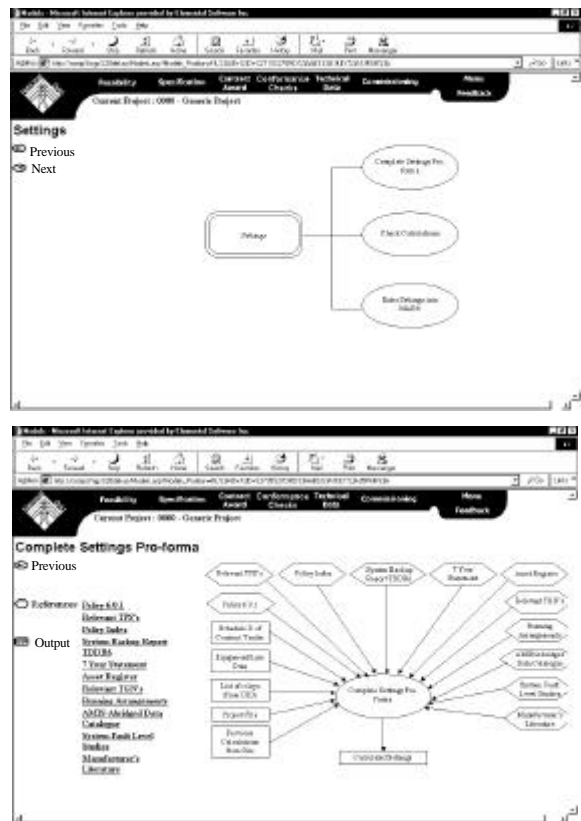

Figure 4: Settings Knowledge Models

**DISCUSSION OF THE PERCEIVED BENEFITS OFFERED TO THE PROTECTION DESIGN PROCESS BY DEKAS**

A common problem encountered by companies with multiple disciplines is the formation of technology silos (i.e. isolated areas of detailed knowledge). When a design relies upon input from a number of different disciplines, the necessary interfaces often remain neglected until the design comes together at the project manager's desk. DEKAS is intended to foster a more co-operative and consistent approach to protection scheme design.

The introduction of a knowledge management strategy through DEKAS presents the protection design process with a number of benefits.

At the 'front-end' of the design process, DEKAS will improve the quality of data and information available to the engineer at the inception of a design by standardising the capture, storage and dissemination of data and information throughout the course of all design projects.

At the 'delivery-end' of the design process, DEKAS will optimise the core design process time, providing engineers with more time for checking and modification of designs, resulting in fast and accurate final protection scheme designs.

'People' benefits include improved 'on job training'. At present 'on job training' requires experienced personnel to commit a significant proportion of their time to the education and training of less experienced personnel. DEKAS aims to supplement existing training methods in order to reduce the teaching and learning time associated with new, less experienced engineers through the provision of on-line decision support and guidance throughout the design process.

## CONCLUSION

The nature of the work carried out within protection design is such that a number of engineers, possibly dispersed over a wide geographical area, may be involved in similar activities and may therefore experience similar, frequently occurring project related issues and problems. Knowledge engineering techniques have led to the capture of this engineering experience and know-how and enabled the derivation of case parameters representative of a 'typical' design project. This knowledge has been represented and implemented within DEKAS using KADS modelling (1) and CBR techniques (3), with a view to promoting company-wide sharing and re-use of protection design knowledge.

Knowledge management is concerned with pushing relevant information to relevant parties for the completion of a particular task or project (5). DEKAS combines information and data available within existing repositories with engineering experience residing

within the evolving system case base, to provide the engineer with intelligent decision support for protection scheme design. The system effectively provides the user with knowledge and understanding of the practical constraints, commonly occurring problems and idiosyncrasies encountered during previous designs and applications, and the resulting lessons learned.

Through the promotion of knowledge retention and sharing, and the fostering of a 'best practice' within protection design, DEKAS ultimately seeks to optimise the design process cycle, getting more designs 'right first time, on time'.

## ACKNOWLEDGEMENTS

The authors gratefully acknowledge the contributions of ScottishPower and National Grid to the work described within this paper.

## REFERENCES

1. B.J Wielinga., A.Th Schreiber, J.A. Breuker, 1992, KADS: A Modelling Approach to Knowledge Engineering, Knowledge Acquisition Vol.4.
2. Schreiber, Ahhermans, Anjewierden, de Hoog, Shadbolt, Van de Velde and Wielinga, 1999, Knowledge Engineering and Management, The MIT Press.
3. Watson, 1997, Applying Case-Based Reasoning: Techniques for Enterprise Systems, Morgan Kaufmann, pp. 15-38.
4. M. Firlej, D. Hellens, 1991, Knowledge Elicitation – A Practical Handbook, Prentice-Hall International.
5. G.M. West, S.M. Strachan, A. Moyes, J.R. McDonald, 2000, "Knowledge Management and Decision Support for Electrical Power Utilities", The Proceedings of KMAC2000 - Knowledge Management After the Chaos.