

Strathprints Institutional Repository

Wood, J. (2003) *The development of procedural benchmarks for modelling common fabrication details in plate/shell structures*. In: 4th FENET Technology Workshop, 2003-02-26, Barcelona.

Strathprints is designed to allow users to access the research output of the University of Strathclyde. Copyright © and Moral Rights for the papers on this site are retained by the individual authors and/or other copyright owners. You may not engage in further distribution of the material for any profitmaking activities or any commercial gain. You may freely distribute both the url (<http://strathprints.strath.ac.uk/>) and the content of this paper for research or study, educational, or not-for-profit purposes without prior permission or charge.

Any correspondence concerning this service should be sent to Strathprints administrator: <mailto:strathprints@strath.ac.uk>



Wood, J.* (2003) The development of procedural benchmarks for modelling common fabrication details in plate/shell structures. In: 4th FENET Technology Workshop, Barcelona, Spain.

<http://eprints.cdlr.strath.ac.uk/6348/>

Strathprints is designed to allow users to access the research output of the University of Strathclyde. Copyright © and Moral Rights for the papers on this site are retained by the individual authors and/or other copyright owners. You may not engage in further distribution of the material for any profitmaking activities or any commercial gain. You may freely distribute both the url (<http://eprints.cdlr.strath.ac.uk>) and the content of this paper for research or study, educational, or not-for-profit purposes without prior permission or charge. You may freely distribute the url (<http://eprints.cdlr.strath.ac.uk>) of the Strathprints website.

Any correspondence concerning this service should be sent to The Strathprints Administrator: eprints@cis.strath.ac.uk

The Development
of
“Procedural Benchmarks”
for
Modelling Common Fabrication Details
in
Plate/Shell Structures

FENET Workshop
Barcelona
27th and 28th February 2003

Jim Wood
University of Strathclyde



Outline Proposal

- **To examine the procedures used in the various FENET industry sectors, for the “routine” modelling and assessment of common fabrication details in plate/shell construction.**
- **To use the unique forum provided by FENET to develop “procedural benchmarks” or “effective methodologies” for some of these features and to disseminate agreed best practice.**
- **This development to be the subject of the next 2 Education and Dissemination workshops following Barcelona.**
- **The activity will involve “round-robin” modelling and assessment of these simple fabrication details, with the procedures and results forming the basis of presentations and discussions at the workshops.**
- **Assuming agreement is reached on “best practice”, this would then be documented and produced as a FENET deliverable.**

Suggested Details

- This list is provided as a basis to commence discussions and to provide a “flavour” of what is being proposed. It is anticipated that these suggestions will be modified, enhanced and possibly replaced by more suitable ones arising from this meeting. It is suggested that one or two be selected for development in the first instance.
- The following “common” details are relevant
 - 1** The intersection of plates and shells
 - without weldments
 - with weldments of different types
 - 2** “Wrapper”, “compensation” or “spreader” plates
 - welded around the periphery only
 - welded around the periphery and also with internal “puddle” or “spot” welds, to provide greater connectivity
 - 3** Offset shell midsurfaces (e.g. lap joints)
 - 4** Bolted connections

Characteristics of the procedural benchmarks

- **Problem definition to be as simple as possible, while still capturing the essence of the modelling and assessment practicalities.**
- **Allow use of the most common relevant element types, whilst recognising that procedural benchmarks developed for say 2D plane strain and 2D axisymmetric situations will also provide guidance for 3D brick applications. The relevant element types include ... 2D Plane stress/strain/axisymmetric, thin shell of revolution, general plate/shell elements and 3D bricks.**
- **In the first instance, avoiding explicit modelling of material nonlinearity ... the aim being to provide guidance in a “routine” design environment for static strength and fatigue. It may be the case that these “procedural benchmarks” can be extended to more complex assessment scenarios in the future.**
- **Finite element modelling and assessment approaches in many sectors will be inherently linked to codes of practice and allowables therein. The use of empirical data for strength reduction factors may also be prevalent in some approaches to assessment. Any “round-robin” or procedural benchmarking exercise will therefore have to make reference to the methods of assessment.**

1 Some thoughts on intersections ...

- **Models with plate/shell elements include the inherent approximations and assumptions associated with plate/shell theory, including mid-surface representation of geometry, linear through-thickness stress ... and others depending upon order of shell theory used.**
- **Modelling with bricks” often presents difficulties associated with the theoretically infinite stresses that exists at re-entrant corners modelled without a fillet radius. Results at such locations are commonly quoted in reports, in spite of the values being a function of mesh refinement and tending to infinity.**

A CYLINDER WITH FLAT END CLOSURES

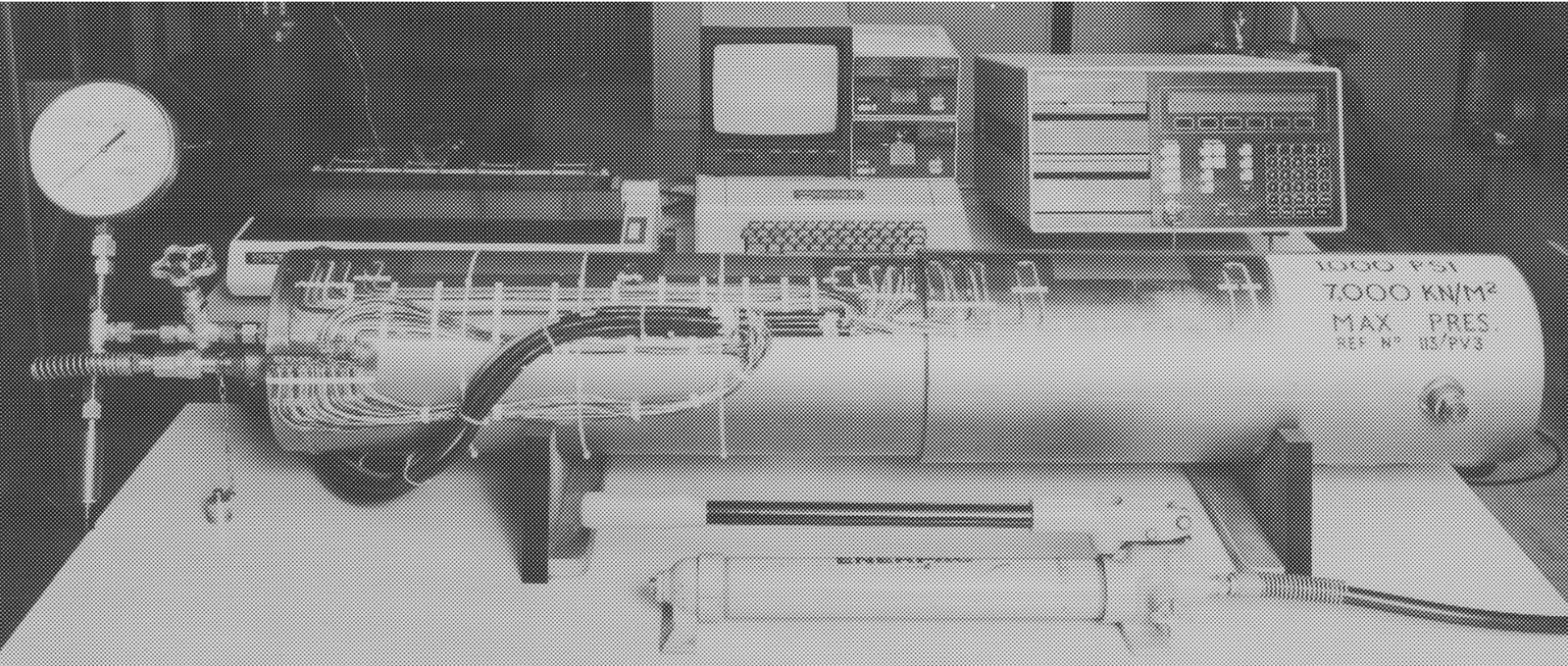

An illustrative study of the shell intersection problem ...



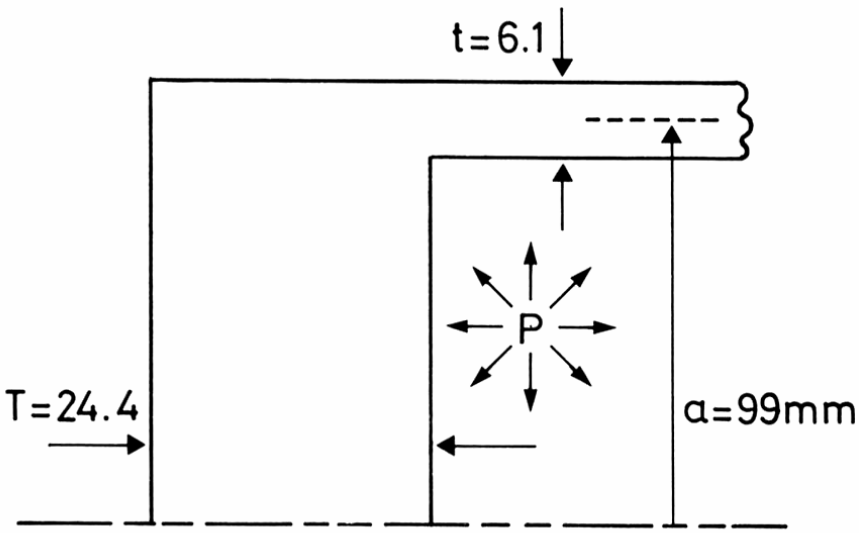

(a) DIMENSIONS

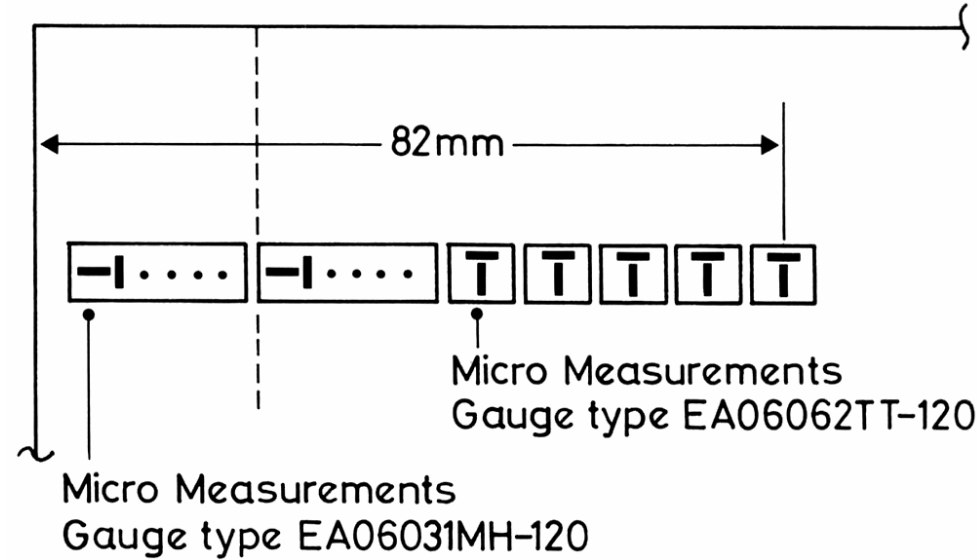

(b) STRAIN GAUGE DETAILS

Cylinder details

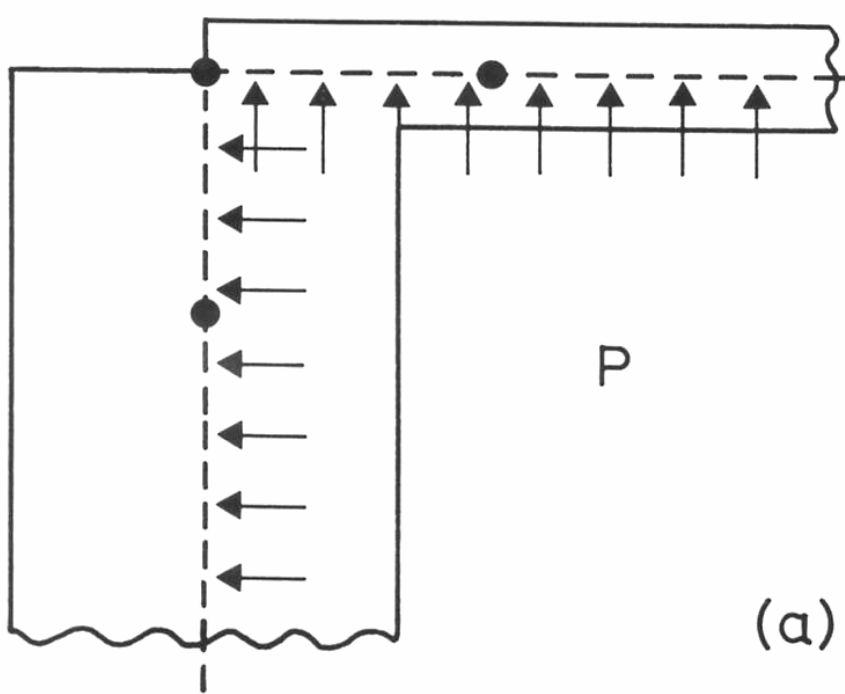

(a)

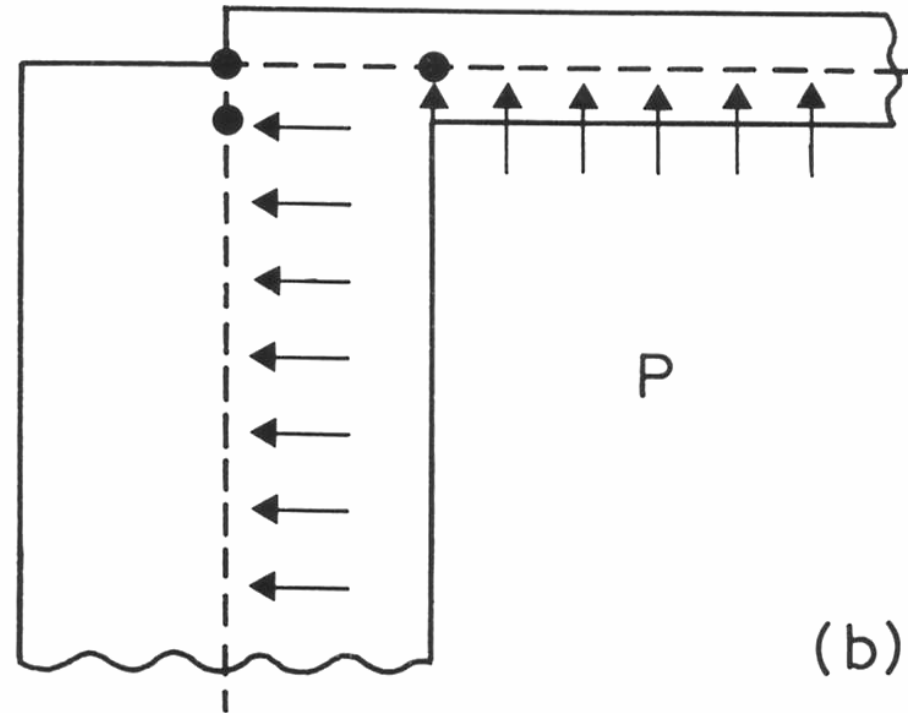

(b)

"Basic" axisymmetric thin shell models

Axisymmetric thin shell models with modified intersection geometry

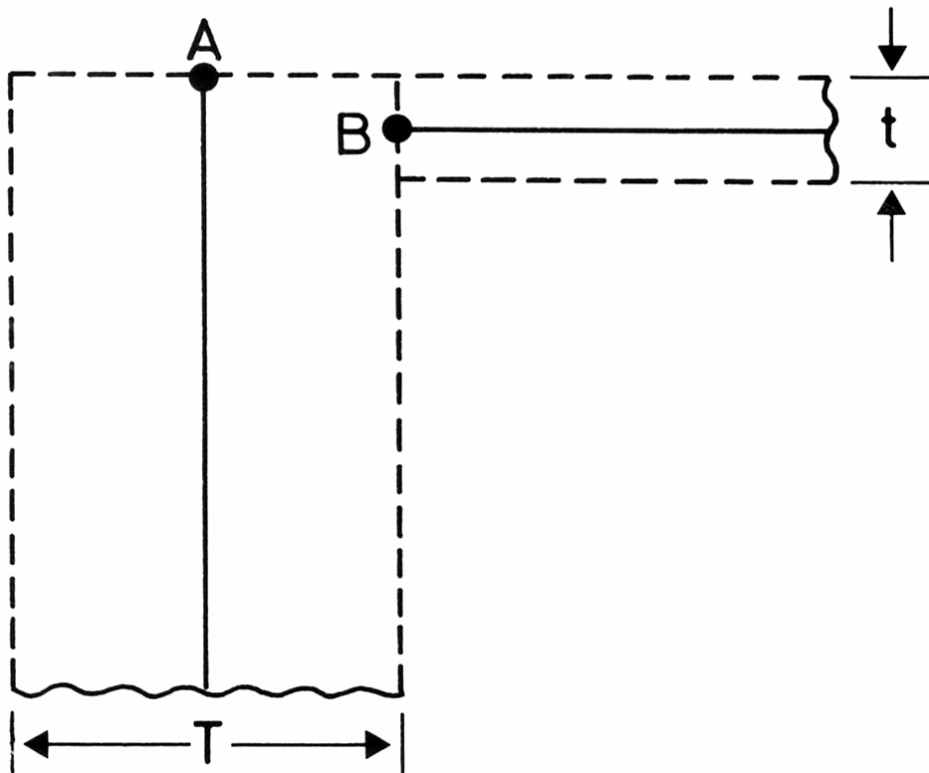

- (i) Repeated Freedoms: nodes A+B have identical freedoms
- (ii) High Stiffness Element.: nodes A+B form the end nodes of an axisymmetric element of high stiffness i.e. thickness = 0.10205m.
- (iii) Generalized Constraints : nodes A+B are connected via a 'rigid link'

Constraint relations

$$U_{XB} = U_{XA} + t/2 \varnothing Z_A$$

$$U_{YB} = U_{YA} + T/2 \varnothing Z_A$$

$$\varnothing Z_B = \varnothing Z_A$$

AN ABAQUS APPROACH

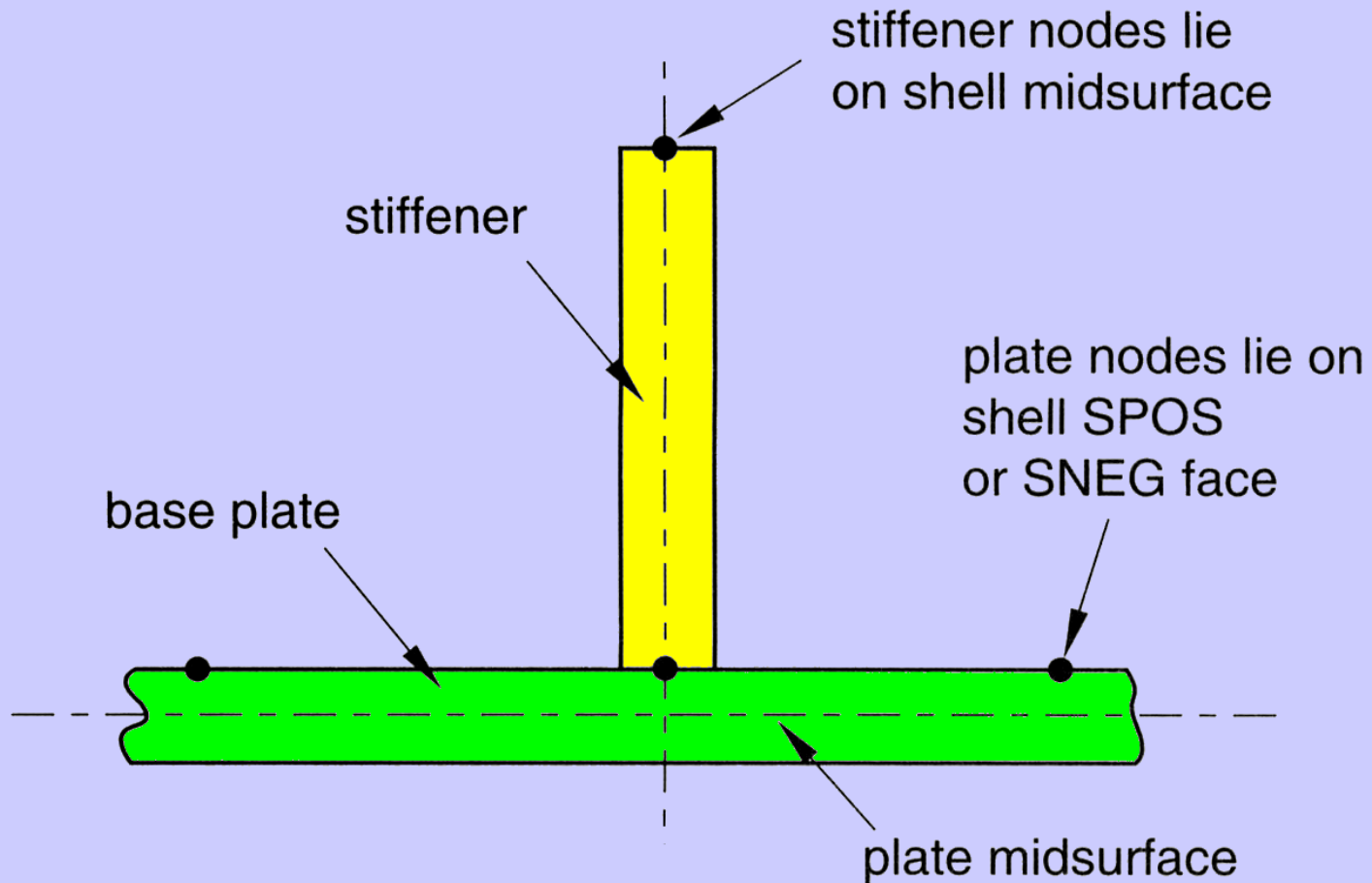

*** SHELL SECTION, OFFSET = SPOS,**

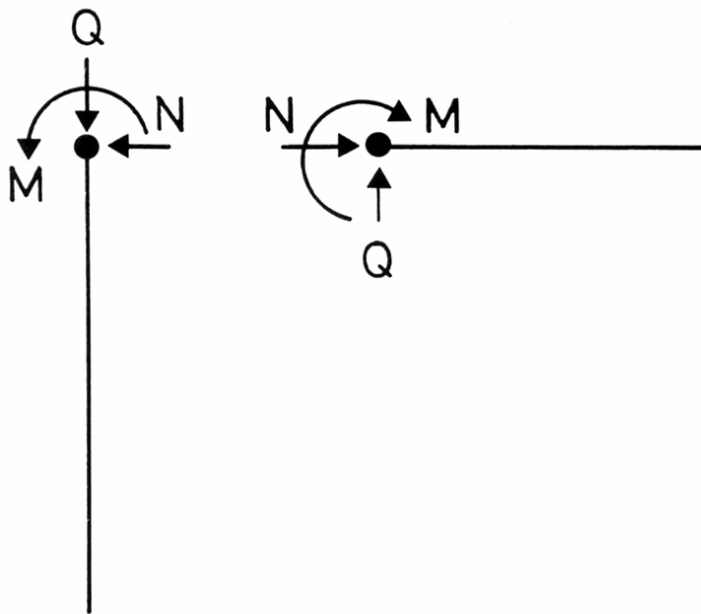

(a) Simple shell representation

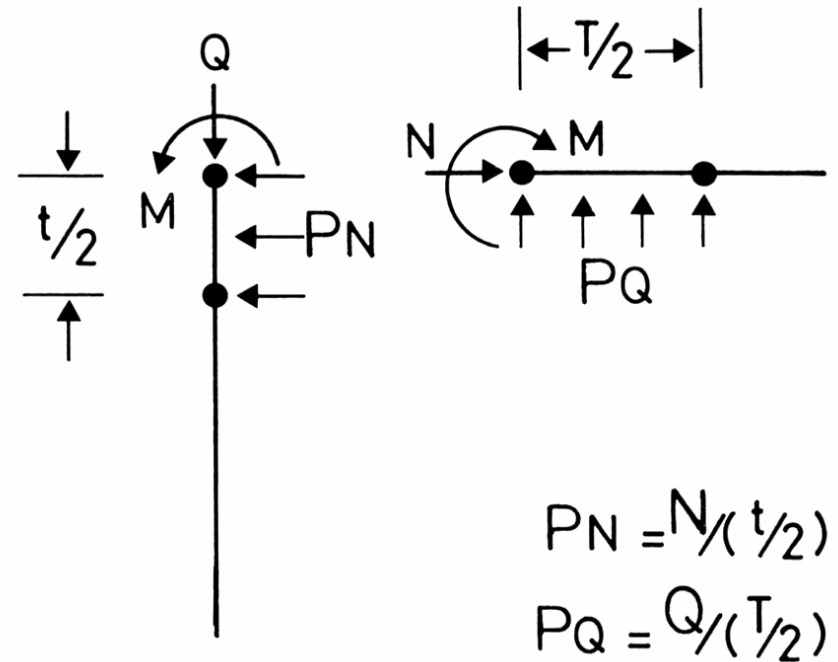

(b) Equivalent band replacement representation

“Equivalent band replacement” model

A comparison of local deformation in the region of the intersection ... note the differences.

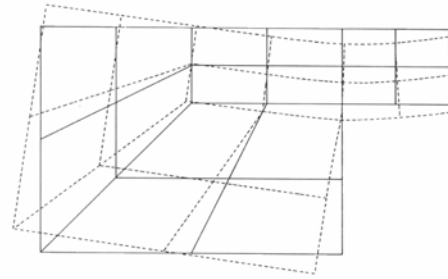

(a) Axi-Hybrid



(b) 'Basic' Axi-thin Shell
(case (b) Fig. 3)



(c) Repeated Freedoms

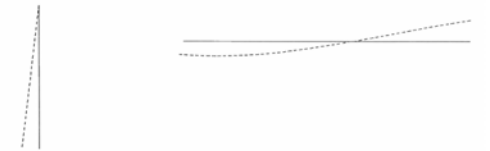

(d) Generalized Constraints
(Rigid Link)

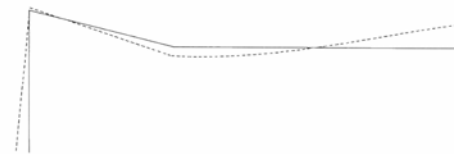

(e) High Stiffness Element



(f) Equivalent Band Replacement

All to same scale.

A possible model ...

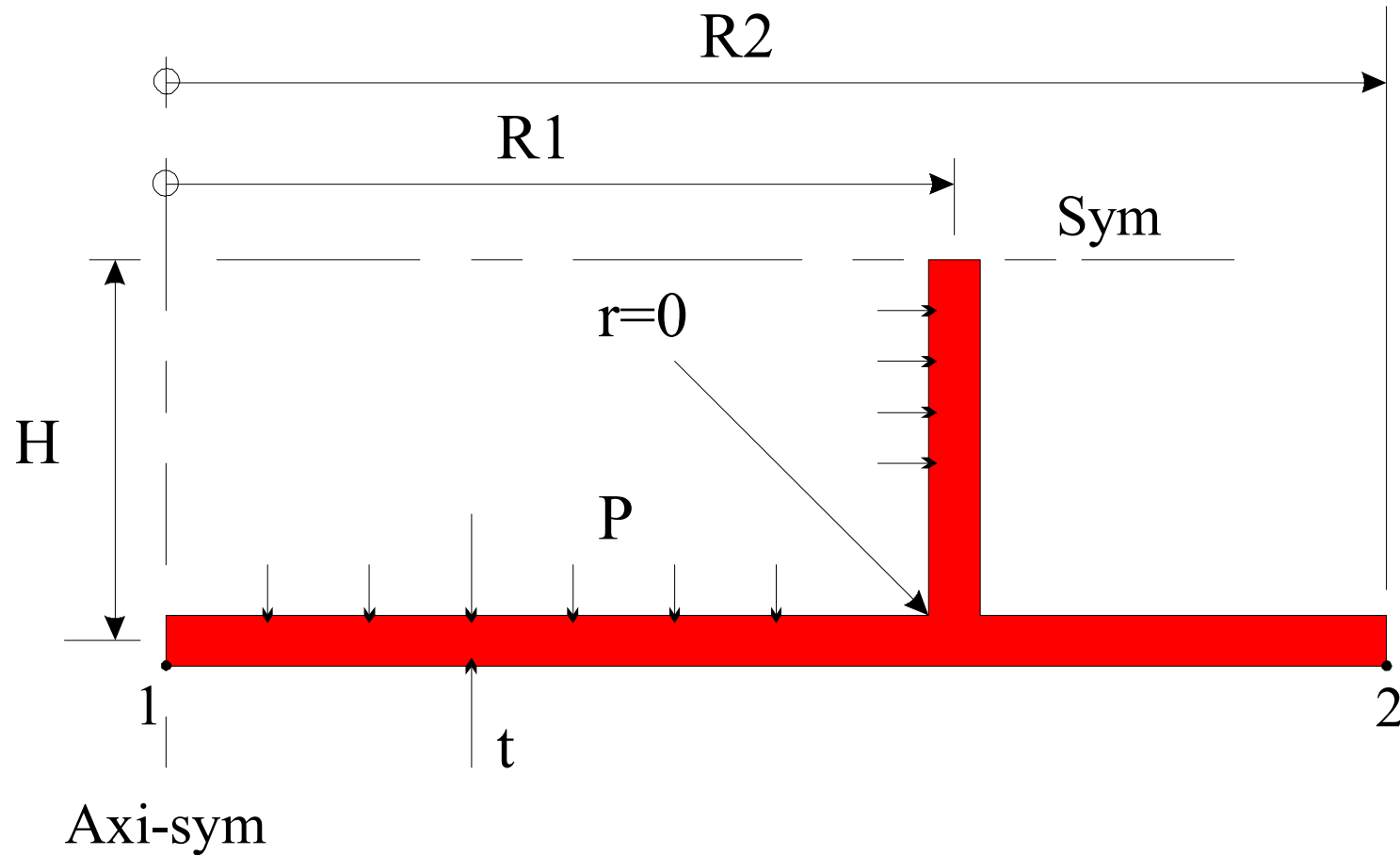

A possible modelling strategy

- **Most of the modelling approaches can be examined effectively in 2D, with the lessons being applicable for the generalised 3D cases.**
- **The axisymmetric nature of the model introduces the additional interest of a hoop stress, which may be affected differently by the idealisations used.**
- **Two element types :**
 - **A(i) : Axi-shell representation**
 - **A(ii) : 2D solid of revolution representation**
- **Possible goals:**
 - **Deflection at points 1 and 2**
 - **Bending stress at points 1 and 2**
- **Assessment of the stress levels at the intersection ... to compare with static allowables and fatigue**

A couple of variations ... full penetration and partial penetration welds.

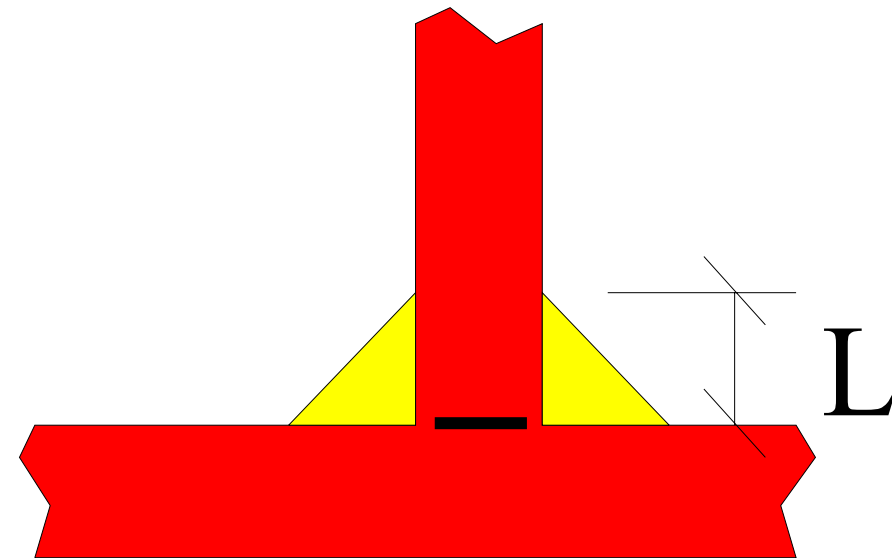
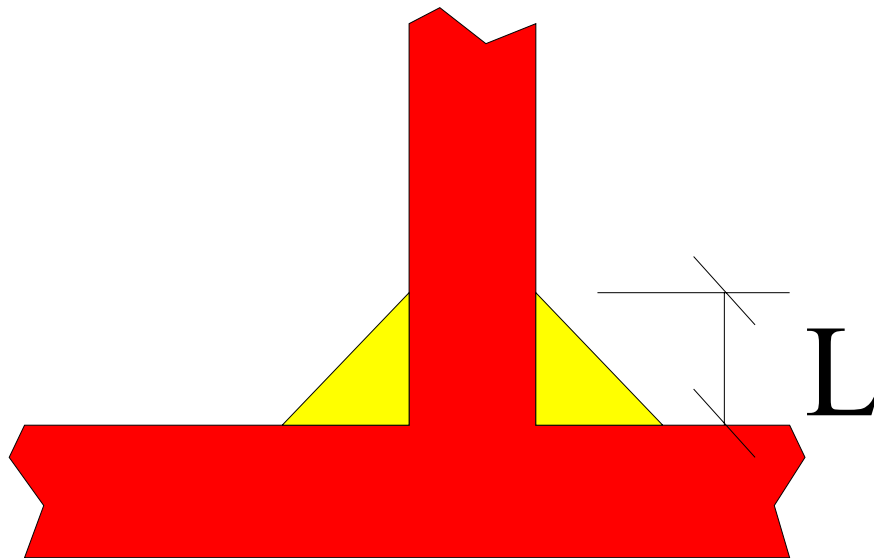

- **What difference does the weld detail make to your modelling and assessment procedure?**
- **Do you have a rapid and effective way of sizing the welds in 3D shell and brick models?**

Concluding comments on the intersection problem 1

- **Concerns regarding the validity and use of shell and 3D brick stresses from intersections have been expressed for a long time.**
- **In the 1970s a comparison of various stress analysis methodologies (strain gauge, photoelasticity, shell and brick fea) for chord-brace intersections in jacket structures, was made as part of UKOSRP (United Kingdom Offshore Steel Research Project).**
- **This led to a proposal for a procedure to obtain consistent and repeatable “hot-spot” stresses, that was independent of stress analysis methodology employed. This basically involved creating a distribution of stress (which had been “displaced” by a distance that was a function of shell thickness and intersection angle, if shell elements had been employed) and then extrapolating this distribution to the toe of the weld under consideration.**
- **Was this ever adopted by industry (offshore and wider) ... embodied in codes of practice? Were software postprocessing tools ever developed to facilitate this procedure? Was it too unwieldy? The basic elements and software have not really changed I suspect ... is this worth revisiting?**

Concluding comments on the intersection problem 2

- **A further approach involves modelling with 3D general shells (ignoring explicit representation of welds in the actual model). A band of elements half a shell thickness plus a weld leg length wide is modelled running along every intersection. It is the stresses on the bounding line corresponding to the toe of the weld that are used for assessment purposes and the stresses within the band are effectively ignored. In this case, while the structures involved are not pressure vessels, the company using the above modelling approach, uses the philosophy inherent in BS5500 for assessment purposes. Is this just one of many examples of in-house developed procedures for handling such detail ... refined over the years as field data becomes available?**
- **Do the basic concerns regarding accuracy and validity still exist across industry sectors or does industry ignore or turn a blind eye to such variability? Or do they have “best practice” solutions!**
- **What about companies now turning to fea ... where do they get guidance on such matters from?**

2 Some thoughts on wrapper/spreader plates ...

- **Detail is common in fabricated structures in regions of stress concentration such as connections, junctions, nozzles etc.**
- **Aim is generally to reduce the effects of the stress concentration and/or to spread the load effectively at the location.**
- **To avoid the use of forgings or thicker plate locally, with the associated fabrication complexity and cost, separate plates are often added or “wrapped” around the detail.**
- **These separate plates are welded around the profile boundary and possibly spot-welded or “puddle-welded” internally, in an attempt to ensure better connectivity.**
- **The following simple model is suggested as a means of highlighting the significance of some of the assumptions inherent in modelling such detail.**

A possible model ...

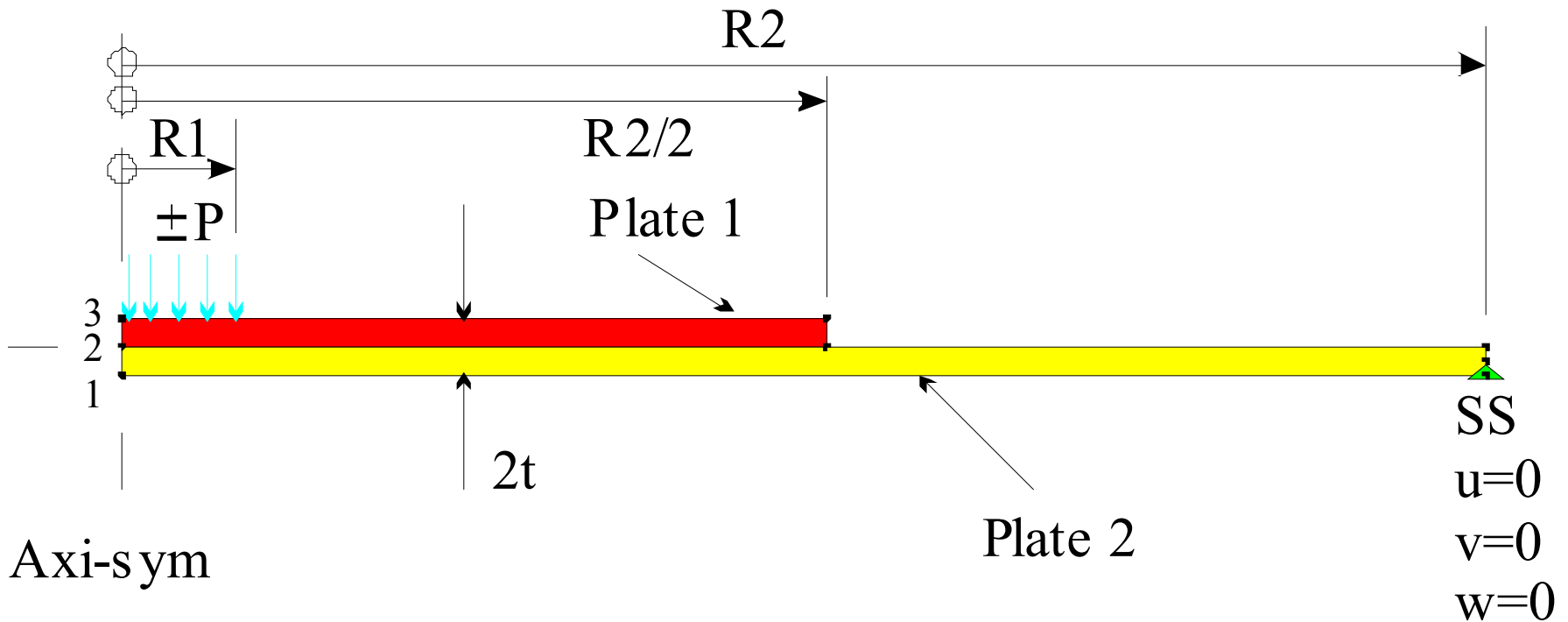

$R2/t = ?$

Load case 1 : $+p$ (ie upwards)

Load case 2 : $-p$ (downwards)

A possible modelling strategy

- To be modelled with 2D solid of revolution elements and also with axisymmetric shell elements (provides same lessons as use of general shell elements and 3D bricks)
- Analysis sequence
 - 2(a) : “Solid” construction ie machined from the solid with thickness “ $2t$ ”; (with offset midsurface and without?)
 - 2(b) : Separate plates, welded at $R/2$ only and with no contact between plates;
 - 2(c) : As (b) but with contact between plates (no friction);
 - 2(d) & (e) : As (b) & (c) but with addition spot/puddle weld centred on $R/4$. Radius of spot/puddle weld = t ;
 - Increase number of equi-spaced welds until plates effectively behave as one, for each load-case ... in terms of overall stiffness and field-stress level in plates, whilst highlighting any local stress concentrations arising from the fabrication detail.

- **Possible Goals:**
 - **Deflection at points 1,2 and 3**
 - **Hoop stress at points 1,2 and 3**
 - **Radial stress at points 1,2 and 3**
 - **Distribution of vertical displacement along the top surface of plate 1 and bottom surface of plate 2.**
 - **Distribution of hoop stress along the top surface of plate 1 and bottom surface of plate 2.**
 - **Distribution of radial stress along the top surface of plate 1 and bottom surface of plate 2.**
- **Further areas for comment:**
 - **Accuracy of stresses in the vicinity of the spot/puddle welds;**
 - **The possible effects of friction between the plates;**
 - **General industry-specific guidance on the pitch of such spot/puddle welds, with respect to plate dimensions, to ensure full connectivity.**
- **Possible extension of this study would be to consider a rectangular plate, with a view to verifying any “pitch” lessons from above.**

3 Some thoughts on offset plate/shell midsurfaces ...

- **Offset plate/shell midsurfaces exist in the common detail of a lap joint and some of the uncertainties associated with this feature are also present in the previous “wrapper” plate problem.**
- **Various approaches to this detail are taken when modelling with shell elements, including ...**
 - **(1) neglect of the offset, with an average thickness used over the lap.**
 - **(2) neglect of the offset, with an double thickness used over the lap.**
 - **(3) the use of links or constraints to provide connectivity and the offset load path.**

A possible model ...

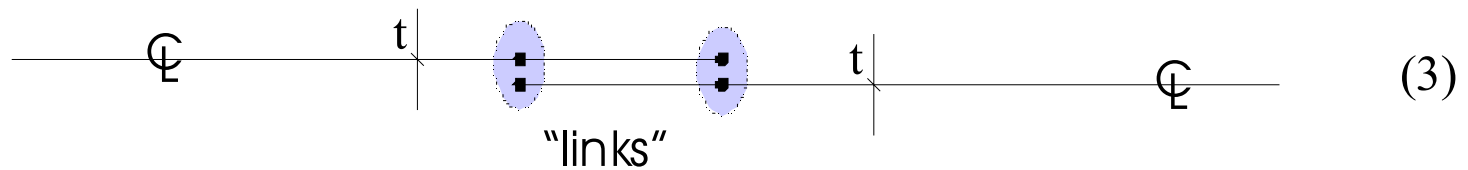
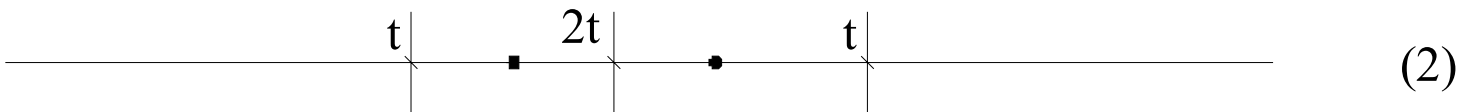
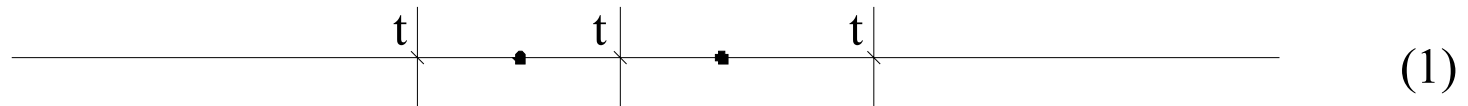
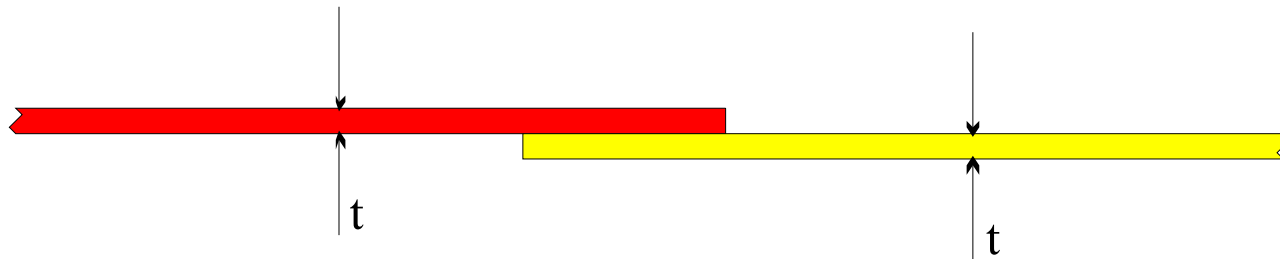

Areas that could be explored in the context of this detail ...

- **The significance of the above model details in various analysis types ie linear statics, fatigue, natural frequency, buckling etc.**
- **The accuracy of the stresses in the vicinity of the detail?**
- **Is there an adequate representation of stiffness?**

4 Some thoughts on bolted joints ...

- **Commonplace but complex**
- **Varying levels of complexity depending on purpose of analysis**
- **Variables include :**
 - **Bolt type**
 - **Bolt/hole clearance;**
 - **Bolt pre-load;**
 - **% of load transferred between plates due to bolt/plate bearing and washer/plate friction;**
 - **Torquing-up sequence effects;**
 - **Gasket type .. if relevant.**
 - **The effects of manufacturing and assembly variability.**

In conclusion ...

- Is there the essence of some useful FENET E&D activity here?
- If so

 - can we knock one or two of these into shape?
 - or does anyone have alternative suggestions?

- Will your organisation be willing to participate in ...
 - agreeing a definition for selected problems?
 - running the selected problems in a “round-robin” exercise?
 - sharing your findings at the next E&D workshop?
- There are a lot of companies out there fabricating rather mundane structures and sub-assemblies, who are perhaps moving into the fea area for the first time (many of them SMEs) ... can we disseminate best practice to these organisations, whilst at the same time learning from other industry sectors?
- **Questions and comments please!**

