



## Strathprints Institutional Repository

Chefles, Anthony and Gilson, Claire R. and Barnett, Stephen M. (2001) *Entanglement, information and multiparticle quantum operations*. Physics Letters A, 63 (3). 032314-1-032314-15. ISSN 0375-9601

Strathprints is designed to allow users to access the research output of the University of Strathclyde. Copyright © and Moral Rights for the papers on this site are retained by the individual authors and/or other copyright owners. You may not engage in further distribution of the material for any profitmaking activities or any commercial gain. You may freely distribute both the url (<http://strathprints.strath.ac.uk/>) and the content of this paper for research or study, educational, or not-for-profit purposes without prior permission or charge.

Any correspondence concerning this service should be sent to Strathprints administrator: <mailto:strathprints@strath.ac.uk>



Chefles, Anthony and Gilson, Claire R. and Barnett, Stephen M.\* (2000) Entanglement, information and multiparticle quantum operations. *Physics Letters A*, 273 (1-2). pp. 10-14. ISSN 0375-9601

<http://eprints.cdlr.strath.ac.uk/5849/>

This is an author-produced version of a paper published in *Physics Letters A*, 273 (1-2). pp. 10-14. ISSN 0375-9601. This version has been peer-reviewed, but does not include the final publisher proof corrections, published layout, or pagination.

Strathprints is designed to allow users to access the research output of the University of Strathclyde. Copyright © and Moral Rights for the papers on this site are retained by the individual authors and/or other copyright owners. You may not engage in further distribution of the material for any profitmaking activities or any commercial gain. You may freely distribute both the url (<http://eprints.cdlr.strath.ac.uk>) and the content of this paper for research or study, educational, or not-for-profit purposes without prior permission or charge. You may freely distribute the url (<http://eprints.cdlr.strath.ac.uk>) of the Strathprints website.

Any correspondence concerning this service should be sent to The Strathprints Administrator: [eprints@cis.strath.ac.uk](mailto:eprints@cis.strath.ac.uk)

# Entanglement, Information and Multiparticle Quantum Operations

Anthony Chefles

*Department of Physical Sciences, University of Hertfordshire  
Hatfield AL10 9AB, Herts, UK  
email: A.Chefles@herts.ac.uk*

Claire R. Gilson

*Department of Mathematics, University of Glasgow, Glasgow G12 8QQ, UK*

Stephen M. Barnett

*Department of Physics and Applied Physics, University of Strathclyde  
Glasgow G4 0NG, UK*

Collective operations on a network of spatially-separated quantum systems can be carried out using local quantum (LQ) operations, classical communication (CC) and shared entanglement (SE). Such operations can also be used to communicate classical information and establish entanglement between distant parties. We show how these facts lead to measures of the inseparability of quantum operations, and argue that a maximally-inseparable operation on 2 qubits is the SWAP operation. The generalisation of our argument to  $N$  qubit operations leads to the conclusion that permutation operations are maximally-inseparable. For even  $N$ , we find the minimum SE and CC resources which are sufficient to perform an arbitrary collective operation. These minimum resources are  $2(N - 1)$  ebits and  $4(N - 1)$  bits, and these limits can be attained using a simple teleportation-based protocol. We also obtain lower bounds on the minimum resources for the odd case. For all  $N \geq 4$ , we show that the SE/CC resources required to perform an arbitrary operation are strictly greater than those that any operation can establish/communicate.

PACS numbers: 03.67.-a, 03.67.Hk

## I. INTRODUCTION

Many of the novel information-theoretic properties of quantum systems are attributable to the existence of entanglement. Entanglement is responsible for the non-local correlations which can exist between spatially separated quantum systems, as is revealed by the violation of Bell's inequality [1]. It also lies at the heart of several intriguing applications of quantum information, such as quantum teleportation [2], quantum computational speed-ups [3,4] and certain quantum cryptographic protocols [5].

The central position of entanglement in quantum information theory, and its usefulness in applications, has led to considerable efforts being devoted to finding a suitable measure of how much entanglement a quantum system contains. This problem has been solved completely for bipartite pure states [6], and the accepted measure

is the subsystem von Neumann entropy, conventionally taken to the base 2, so that a maximally-entangled state of a pair of two-level quantum systems, or *qubits* [7], possesses one unit of entanglement. This fundamental unit is known as an *ebit*.

The production of entanglement requires the transmission of quantum information between systems. Conversely, the transmission of quantum information between systems can be used to establish entanglement between them. Perhaps the most perfect expression of this duality is the fact that there are two equivalent definitions of the quantum capacity of a communications channel [8]. According to one definition [9], it is the asymptotic maximum amount of quantum information that can be transmitted per use of the channel, measured in qubits. In the other [10], it is the asymptotic maximum number of ebits of entanglement that can be established between the sending and receiving stations, again per use of the channel. An important consequence of this equivalence is the fact that no entanglement can be created without the transmission of quantum information. That is, no entanglement can be created when only local quantum operations are allowed, and only classical information can be transmitted.

Collective quantum operations involving multiple quantum systems can create entanglement and be used to communicate classical information. Conversely, the use of entanglement shared by spatially-separated laboratories, in addition to facilities enabling classical communication and arbitrary local quantum operations, permit these laboratories to carry out collective operations upon a network of separated quantum systems. The ability to do this will have interesting implications for many potential applications of quantum information, such as distributed quantum computing, network quantum communication and the production of novel multiparticle entangled states.

This paper extends the analysis presented in [11], where we examined the entanglement resources required to carry out collective quantum operations upon  $N$  qubits, in particular, for the case of even  $N$ . In addition to giving a fuller treatment of this problem, including an analysis of the odd case, we examine the classical com-

munication resources required to carry out an arbitrary collective operation upon  $N$  qubits, and also the amount of classical information that such an operation can be used to send. An intriguing issue highlighted by these considerations is that of how we might quantify the ‘inseparability’ of a quantum operation, rather than that of a quantum state. As we shall see, this inseparability has both classical and quantum aspects.

In section II, we examine the use of entanglement and classical communication to carry out arbitrary collective operations upon a pair of qubits. A simple protocol for achieving this, which uses quantum teleportation, is proposed. Two classical and two quantum measures of the inseparability of a quantum operation arise naturally from these considerations. The quantum measures are analogous to the entanglement of formation [12] and distillation [13] of quantum states. These are respectively the minimum amount of entanglement required to perform the operation, and the maximum amount of entanglement that the operation can establish. The classical measures of inseparability are respectively the minimum amount of classical information required to perform the operation, and the maximum amount of classical information that the operation can be used to communicate. The relationship between these measures leads to the conclusion that a maximally-inseparable quantum operation is the SWAP operation, or any other which can be obtained from it by local unitary transformations.

The remainder of this paper is concerned with collective operations upon  $N$  qubits. The particular issues we address are: how much bipartite entanglement can an operation be used to establish and how much information can it be used to communicate? Also, how much bipartite entanglement and classical information are needed to perform an arbitrary operation?

In section III, we develop a graph-theoretic framework for the representation of bipartite entanglement and communication networks for  $N$  laboratories. Using this framework, we generalise to the case of  $N$  qubits our teleportation protocol. We show that this protocol is optimal in the class of protocols which operate by state teleportation. We also generalise our discussion of quantifying the inseparability of quantum operations to the  $N$ -particle case. As far as the ‘distillation’ measures are concerned, which quantifies the ability of a quantum operation to establish entanglement and communicate classical information, we find that permutation operations are maximally-inseparable. These operations can establish the largest amount of entanglement, and be used to communicate the largest amount of classical information.

In section IV, we are concerned with minimising the entanglement and communication resources required to perform an arbitrary quantum operation upon  $N$  qubits. There are two distinct scenarios to consider here. On the one hand, we may wish to determine the minimum resources required to carry out an arbitrary operation just once. We refer to this as the ‘one-shot’ scenario. On the other hand, it may be the case that the  $N$  laboratories

share a very large amount of entanglement, and are able to communicate large amounts of classical information. They may wish to use these resources with maximum efficiency to carry out an arbitrary operation many times. The limit as both the resources and the number of repetitions of the operation tends to infinity is known as the *asymptotic* limit. In this scenario, the asymptotically minimum resources are the minimum entanglement and classical communication that must be used, on average, per run of the operation.

We find that in terms of both entanglement and communication, our teleportation protocol is optimal, in both the one-shot and asymptotic scenarios, for even  $N$ . We obtain lower bounds on the minimum resources for the odd case. We show that, for all  $N \geq 4$ , the classical communication and entanglement resources required to carry out an arbitrary operation are strictly greater than the amount of entanglement that can be established, and the amount of classical information that can be sent, by any particular operation. We also show that if the manipulation of these resources obeys the same efficiency restrictions as those found in entanglement swapping [14] and indirect communication, then the teleportation protocol is optimal for all  $N \geq 12$ , and for all  $N \geq 4$  for entanglement resources, in the one shot case if only integer resources are allowed.

## II. OPERATIONS INVOLVING TWO QUBITS

We consider first the simple case of just two qubits. Suppose that two parties, by convention Alice and Bob, occupy laboratories  $A$  and  $B$  which contain qubits  $\alpha$  and  $\beta$  respectively. The Hilbert spaces of these systems are denoted by  $\mathcal{H}_\alpha$  and  $\mathcal{H}_\beta$ , so that the Hilbert space of the collective system  $\alpha\beta$  is the tensor product space  $\mathcal{H}_\alpha \otimes \mathcal{H}_\beta$ . In addition to these systems, Alice and Bob also possess auxiliary local quantum systems, shared entanglement and a two-way classical communication channel. This setup is illustrated in figure (1). Using these resources, Alice and Bob can perform any collective operation by carrying out the following four steps:

**Step 1:** Alice teleports the state of  $\alpha$  to Bob in laboratory  $B$ . This costs 1 ebit of entanglement and 2 classical bits from  $A$  to  $B$ .

**Step 2:** Bob, possibly making use of his auxiliary systems, carries out the operation locally upon the compound system.

**Step 3:** Bob teleports the final state of Alice’s qubit back to her. This costs 1 ebit of entanglement and 2 classical bits from  $B$  to  $A$ .

**Step 4:** (Selective operations only) Bob transmits to Alice any classical information that he might have obtained

at the end of his LQ operation. This step applies only to (generalised) measurements, in which case it would be information about the result.

Thus, the total CCSE resources required to perform an arbitrary collective operation on  $\alpha\beta$  using teleportation, such that Alice and Bob share the same classical information at the end, are

$$2 \text{ ebits} + 2 \text{ bits}(A \rightarrow B) + 2 \text{ bits}(B \rightarrow A) + C_S(B \rightarrow A). \quad (2.1)$$

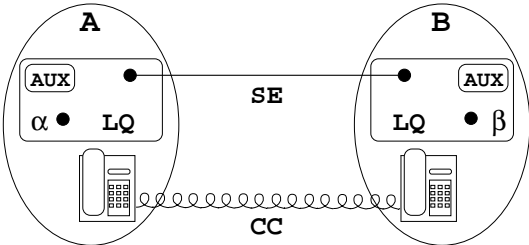

FIG. 1. Illustration of the experimental setup considered in section 2. Laboratories  $A$  and  $B$  contain respective qubits  $\alpha$  and  $\beta$ . Their aim is to perform an arbitrary collective operation on these system using shared entanglement (SE) and a two-way classical communication (CC) channel. They are also able to perform arbitrary local quantum (LQ) operations, possibly involving local auxiliary quantum systems and their respective parts of the entangled systems.

The supplementary information  $C_S(B \rightarrow A)$  is that which is conveyed by Bob to Alice in step 4. This additional information will be created when the operation, represented by a completely-positive, linear, trace-preserving map  $\mathcal{L}$ , is selective. The most general kind of operation which gives rise to non-zero supplementary information is a generalised measurement. A generalised measurement with  $M$  outcomes is described by  $M$  positive, Hermitian operators  $E_r$ , where  $r = 1, \dots, M$  and  $\sum_r E_r = 1$ . These operators form a positive, operator-valued measure (POVM) [15] and each of them corresponds to a distinct outcome. If the initial state of  $\alpha\beta$  is described by the density operator  $\rho$ , then the probability  $p_r$  of obtaining outcome  $r$  is given by  $\text{Tr} \rho E_r$ . The supplementary information generated at Bob's laboratory is given by the Shannon entropy of this distribution

$$C_S = - \sum_{r=1}^M p_r \log_2 p_r. \quad (2.2)$$

This quantity can take on any non-negative real value. Clearly, it is zero when the operation is non-selective. If, however, we consider an operation described by the POVM

$$E_r = \frac{1}{M}, \quad (2.3)$$

where Bob records the outcome, then the supplementary information is equal to  $\log_2 M$ , which diverges as  $M \rightarrow \infty$ . For this operation, one cannot decrease the supplementary information using any information that Alice may have about the initial state  $\rho$ , since the probability distribution is uniform regardless of what the initial state is.

For selective operations, the transmission of this supplementary information will have epistemological significance for Alice which may be important in some applications. She may, for example, wish to carry out some local operation upon her subsystem, depending on the supplementary information she receives from Bob. For the remainder of this paper however, we shall not be concerned with  $C_S$ , and when we speak of the classical information required to complete a quantum operation, we will mean that which is needed to carry it out non-selectively. In this paper, we shall be concerned largely with unitary operations anyway, which are non-selective.

Returning to the teleportation protocol, it may be the case that the CC and SE resources required to perform a *particular* operation,  $\mathcal{L}$ , are less than those required to perform *any* operation, by this method. Let us denote by  $C_R(\mathcal{L} : A \rightarrow B)$ ,  $C_R(\mathcal{L} : B \rightarrow A)$  and  $E_R(\mathcal{L})$  the number of classical bits transmitted in each direction and number of ebits of entanglement required to carry out  $\mathcal{L}$ . These may be regarded respectively as classical and quantum measures of how nonlocal the operation is, and  $E_R(\mathcal{L})$  is therefore somewhat analogous to the entanglement of formation of quantum states [12].

Alternative classical and quantum measures of inseparability arise naturally if we consider the fact that collective operations on quantum systems can be used to transmit classical information and establish entanglement between distant locations. Let us define the quantities  $C_C(\mathcal{L} : A \rightarrow B)$ ,  $C_C(\mathcal{L} : B \rightarrow A)$  and  $E_C(\mathcal{L})$ , respectively the maximum number of classical bits that the operation can be used to communicate in each direction, and the maximum number of ebits of entanglement that it can create between  $A$  and  $B$ .  $E_C(\mathcal{L})$  is correspondingly analogous to the entanglement of distillation of quantum states [13]. We must have

$$C_C(\mathcal{L} : A \rightarrow B) \leq C_R(\mathcal{L} : A \rightarrow B), \quad (2.4)$$

$$C_C(\mathcal{L} : B \rightarrow A) \leq C_R(\mathcal{L} : B \rightarrow A), \quad (2.5)$$

$$E_C(\mathcal{L}) \leq E_R(\mathcal{L}). \quad (2.6)$$

The first two inequalities come from the fact that all classical information that the operation can be used to transmit must, in figure (1), be sent over the classical channel. Equivalently, no classical information can be transmitted using LQSE operations alone. Were this not the case, it would be possible to violate relativistic causality. An intriguing argument for this has recently been described by Eisert *et al* [16]. The third inequality comes from the fact that entanglement cannot increase under LQCC operations. For one-way classical communication, this has been shown by Horodecki and Horodecki [17], to be also

equivalent to the impossibility of superluminal communication.

As a consequence of the teleportation protocol, the minimum CCSE resources required to perform any particular operation will not exceed 2 ebits of entanglement and 2 classical bits each way. The most nonlocal quantum operations with regard to the resource measures  $E_R$  and  $C_R$  are those for which the minimum values of these quantities are both equal to 2. Inequalities (2.4)-(2.6) imply that the maximum values of the  $E_C$  and  $C_C$  cannot exceed 2. Any operation which saturates the limits of 2 on the latter measures must also then saturate inequalities (2.4-2.6), and can be termed a maximally-inseparable operation.

One such operation is the SWAP operation. This is a unitary operation  $U_S$  which, for any state  $|\psi_\alpha\rangle \in \mathcal{H}_\alpha$  and any state  $|\psi_\beta\rangle \in \mathcal{H}_\beta$ , acts as follows:

$$U_S|\psi_\alpha\rangle \otimes |\psi_\beta\rangle = |\psi_\beta\rangle \otimes |\psi_\alpha\rangle, \quad (2.7)$$

that is, it exchanges the states of  $\alpha$  and  $\beta$ . The ability of SWAP to create 2 ebits of entanglement and transmit 2 classical bits each way is easily demonstrated. We shall now do this, with reference to figures (2) and (3). The remarkable properties of the SWAP operation are also described by Collins *et al* [18] and Eisert *et al* [16].

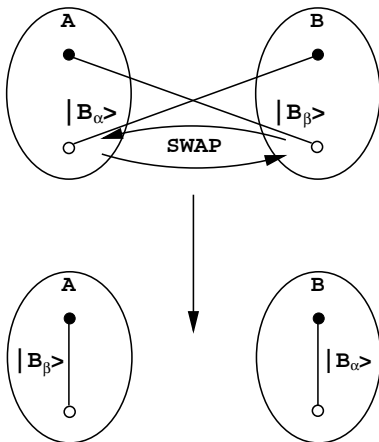

FIG. 2. Illustration of how the SWAP operation can be used to communicate two classical bits each way between Alice and Bob.

In figure (2), Alice and Bob initially share 2 ebits of entanglement in the form of Bell states [19]. Using superdense quantum coding [20], Alice and Bob can each manipulate one of their particles, those represented by hollow circles, to produce any of the 4 Bell states that they wish. The final shared Bell states are  $|B_\alpha\rangle$  and  $|B_\beta\rangle$ . The SWAP operation is then performed on the states of the hollow qubits, resulting in each party being in possession of the entire Bell state which the other party created. Each then performs a Bell measurement, which has 4 possible outcomes and thus reveals 2 bits of

information, showing how SWAP can transmit 2 classical bits each way.

Figure (3) shows how SWAP can be used to establish 2 ebits of entanglement between Alice and Bob. Each party initially possesses 1 local ebit of entanglement. If the SWAP operation is used to interchange the states of one particle from each entangled pair, the result is that Alice and Bob share 2 ebits of entanglement.

Notice that the SWAP operation cannot be used to create 2 ebits of entanglement, and communicate 2 classical bits each way, simultaneously. In fact, looking at figures (3) and (4), we can see that one of these processes is essentially the time-reverse of the other.

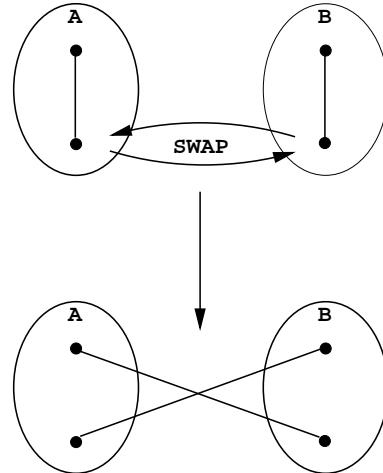

FIG. 3. Illustration of how the SWAP operation can be used to establish 2 ebits of entanglement between  $A$  and  $B$ .

A broader class of maximally-inseparable operations on 2 qubits can be obtained by considering those which are equivalent to SWAP up to a bilateral local unitary operation. Specifically, any unitary operation  $T$  of the form  $T = (U_{\alpha_2} \otimes U_{\beta_2})U_S(U_{\alpha_1} \otimes U_{\beta_1})$  must require the same entanglement and communication resources as  $U_S$ . Here,  $U_{\alpha_i}$  and  $U_{\beta_i}$  are local unitary operations on  $\alpha$  and  $\beta$  respectively. The reason for this is simple: it is possible to convert this operation into the SWAP operation by just local-unitary transformations, that is, without any additional entanglement or classical communication resources. This follows from the simple observation that  $U_S = (U_{\alpha_2}^\dagger \otimes U_{\beta_2}^\dagger)T(U_{\alpha_1}^\dagger \otimes U_{\beta_1}^\dagger)$ .

### III. MULTIPARTICLE SYSTEMS, GRAPHICAL REPRESENTATIONS AND TELEPORTATION.

Let us now extend our discussion to the case of  $N$ -particle systems. Instead of just two spatially-separated laboratories, we now have  $N$  of them, which we label  $A_j$ , where  $j = 1, \dots, N$ . In each of these laboratories is a

qubit, and we label these  $q_j$ . We are interested in the CCSE resources required to perform an arbitrary collective quantum operation involving all  $N$  qubits.

Each laboratory shares a certain number of ebits of entanglement with every other laboratory. In this paper, we shall, except where indicated, take all entanglement to be in pure, bipartite form. The  $N$  laboratories are also linked by classical communication channels, so that each can communicate a certain number of classical bits to the others. Each laboratory also possesses auxiliary quantum systems allowing arbitrary local quantum operations to be performed.

The CCSE resources available to the network of laboratories are conveniently represented using the concepts of graph theory [21]. Recall that a graph  $G = (V, E)$  is a set  $V$  of vertices connected by edges comprising a set  $E$ . If the edges have a sense of direction indicating an asymmetrical relationship between the vertices it connects, the graph is said to be a directed graph, or a digraph. If there is no preferred direction, the graph is undirected.

These resources can be represented by distinct entanglement and communication graphs. Both graphs are comprised of  $N$  vertices, each of which represents one of the laboratories  $A_j$ . The resource entanglement graph  $G_E$  represents the amount of bipartite entanglement shared between each pair of laboratories. Specifically, we write both the  $j$ th laboratory and its corresponding vertex as  $A_j$ . The weight of the edge joining vertices  $A_i$  and  $A_j$  is equal to the number of ebits of entanglement shared by these laboratories. The graph is characterised completely by the  $N \times N$  resource entanglement matrix  $\mathbf{E}_R$ . The element  $E_R^{ij}$  of this matrix is equal to the number of ebits of entanglement shared by  $A_i$  and  $A_j$ . The diagonal elements of this matrix are zero.

Clearly,  $\mathbf{E}_R$  is symmetric and the graph  $G_E$  is undirected. These observations follow from the fact that entanglement is a shared, rather than a directed resource.

As an example, a resource entanglement graph for  $N = 4$  is depicted in figure (4). This corresponds to the following resource entanglement matrix:

$$\mathbf{E}_R = \begin{pmatrix} 0 & 3 & 2 & 6 \\ 3 & 0 & 1 & 0 \\ 2 & 1 & 0 & 0 \\ 6 & 0 & 0 & 0 \end{pmatrix}. \quad (3.1)$$

Likewise, we can define a resource communication graph  $G_C$ . This represents the number of classical bits that the laboratories can communicate directly to each other. By directly, we mean that it is not relayed by a set of intermediate laboratories from origin to destination. The weight of the edge running from  $A_i$  and  $A_j$  represents the number of classical bits that  $A_i$  can communicate directly to  $A_j$ . These weights are the elements of a correspondingly defined resource communication matrix  $\mathbf{C}_R$ . The  $ij$  element of this matrix,  $C_R^{ij}$ , is equal to the number of classical bits that  $A_i$  can communicate directly to  $A_j$ . The diagonal elements of this matrix are

also zero.  $\mathbf{C}_R$  is not necessarily symmetric and the graph  $G_C$  is directed, which follows from the fact that communication operations have a natural sense of direction from sender to receiver. An example of a resource communication graph for  $N = 4$  is given in figure (5), which corresponds to the resource communication matrix

$$\mathbf{C}_R = \begin{pmatrix} 0 & 1 & 4 & 0 \\ 2 & 0 & 0 & 9 \\ 0 & 0 & 0 & 0 \\ 5 & 0 & 0 & 0 \end{pmatrix}. \quad (3.2)$$

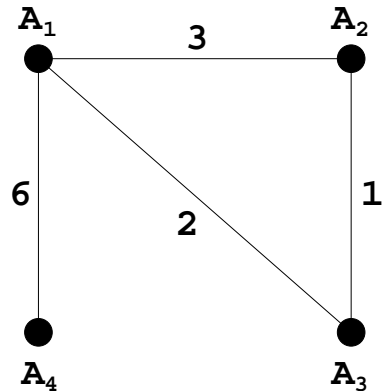

FIG. 4. Example of an entanglement graph  $G_E$  with  $N = 4$ . This corresponds to the resource entanglement matrix  $\mathbf{E}_R$  in Eq. (3.1).

The fact that each pair of vertices may be joined by more than one edge means that  $G_C$  is, strictly speaking, a multigraph, indeed a multidigraph since these edges are directed. We do not, however, wish to unduly proliferate terminology, so we shall simply use the term graph.

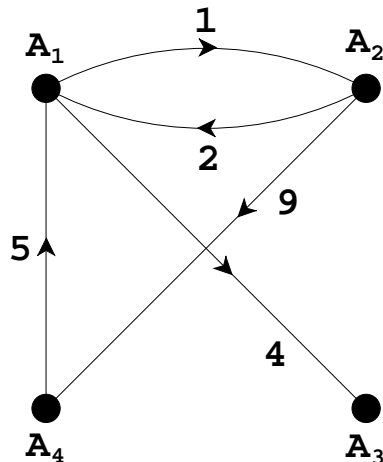

FIG. 5. Example of a communication graph  $G_C$  with  $N = 4$ . This corresponds to the resource communication matrix  $\mathbf{C}_R$  in Eq. (3.2).

In either graph, an edge of weight zero is equivalent to no edge. Thus, if two vertices are not linked by an edge in the graph  $G_E$ , then the corresponding laboratories share no entanglement. Similarly, if there is no edge running

from vertex  $A_i$  to  $A_j$  in the graph  $G_C$ , then  $A_i$  cannot communicate any classical information directly to  $A_j$ .

Two quantities which will be of particular interest to us are the total shared entanglement and the total number of classical bits that can be communicated. Respectively, these are

$$E_R = \frac{1}{2} \sum_{ij} E_R^{ij}, \quad (3.3)$$

$$C_R = \sum_{ij} C_R^{ij}. \quad (3.4)$$

The factor of  $1/2$  in Eq. (3.3) occurs as a consequence of the shared nature of entanglement, which implies that the entanglement shared between each pair of laboratories is counted twice in the summation.

Having established the framework within which we will work, let us now see how such resources can be used to perform an arbitrary collective quantum operation upon the  $N$  qubits  $q_j$ . The teleportation-based procedure for 2 qubits described in the preceding section admits a natural generalisation to the case of  $N$  qubits, which we now describe.

We consider the situation in which all laboratories share entanglement and have the resources for two-way classical communication with one particular laboratory. Let this laboratory be  $A_1$ . It follows that the other laboratories can teleport the states of their qubits to  $A_1$ . The operation can then be carried out at  $A_1$  as an LQ operation. The final states of the other qubits can then be teleported back to their original laboratories, completing the procedure.

This multiparticle protocol generalises the first 3 steps of the 2-qubit protocol described in the preceding section. It requires each of the laboratories  $A_2, \dots, A_N$  to share 2 ebits of entanglement with  $A_1$  and for 2 bits of classical information to be communicated each way between each of them and  $A_1$ . The elements of the corresponding resource entanglement and communication matrices are

$$E_R^{ij} = C_R^{ij} = 2|\delta_{i1} - \delta_{1j}|. \quad (3.5)$$

The corresponding graphs  $G_E$  and  $G_C$  are depicted in figures (6) and (7). The total resource entanglement and communication are

$$E_R = \frac{C_R}{2} = 2(N - 1). \quad (3.6)$$

The graph  $G_E$  representing the entanglement resources required by the teleportation protocol is said to be a *tree*. Generally speaking, a tree is an connected, acyclic graph, that is, one where every pair of vertices is connected by at least one path, and where there are no closed paths.

Any quantum operation on  $N$  qubits can be performed using this method and thus, at least for the topology of entanglement and communication in our protocol, the values of  $E_R$  and  $C_R$  in Eq. (3.6) are sufficient.

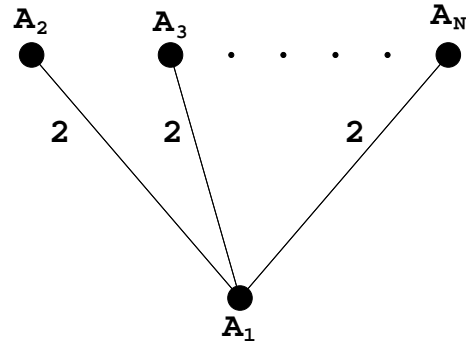

FIG. 6. Resource entanglement graph for the teleportation protocol.

Much of the remainder of this paper will be concerned with the issue of whether or not this protocol is optimal: that is, whether or not there exists a procedure for carrying out any quantum operation on  $N$  qubits which less resources than this protocol. Prior to doing so, it is of interest to determine whether or not this protocol is the most efficient among those that operate by teleportation of the states of the qubits concerned.

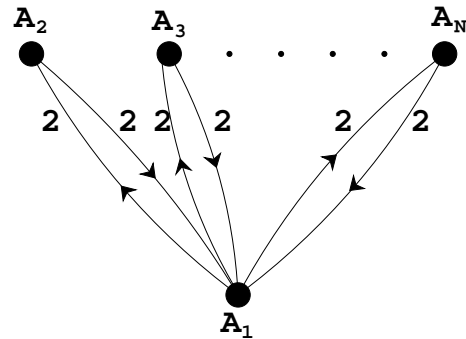

FIG. 7. Resource communication graph for the teleportation protocol.

We have  $N$  laboratories  $A_i$ , each of which possesses a corresponding qubit  $q_i$ . If we wish the  $N$  laboratories to be able to carry out any collective operation upon the  $q_i$  by teleporting single qubits, then, as we now show, at least  $2(N - 1)$  such teleportations must take place.

To see why, suppose that the first teleportation is from  $A_1$  to  $A_2$ .  $A_2$  now has information about  $A_1$ . Secondly another lab  $A_r$  teleports a state to  $A_3$ . If they are completely different labs from the first pairs of laboratories then  $A_3$  can hold information only about one other lab,  $A_r$ . If, however,  $r = 2$ , then  $A_3$  can hold information about 3 qubits,  $q_1, q_2$  and  $q_3$ .

The most efficient way to pass on information is for  $A_3$  to teleport a state  $A_4$  and so on. After  $N - 1$  steps the best possible situation is that one lab  $A_N$  can have information from all of the other labs. None of the other labs can have a complete set of information. So now there must be at least a further  $N - 1$  communication



events required so that each of the first  $N - 1$  labs can get information from lab  $A_N$ . This gives a total of at least  $2(N-1)$  communications in all which costs  $2(N-1)$  ebits.

We saw in the preceding section that the total resource entanglement for an arbitrary operation upon two particles can be recovered if the operation in question is unitarily equivalent to SWAP. Also, for such an operation, the required classical communication facilities required to complete an arbitrary operation can be fully used to communicate useful information. An important question is, does there exist an operation, or class of operations which fulfills this role in the general  $N$ -particle case?

Let us denote the maximum total entanglement that can be established, and the maximum number of classical bits that can be sent by any operation by  $E_C$  and  $C_C$  respectively. To address this issue, it is helpful to partition the entire network of  $N$  qubits into a single qubit and a compound system comprised of the remaining  $N - 1$  qubits. How much entanglement can be established between the location of the isolated qubit and the rest of the network? Also, how much classical information can be transmitted in both directions between the location of this qubit and the remainder?

In the teleportation protocol, a special status was given to laboratory  $A_1$ . However, this choice was arbitrary, and clearly this role could have been assumed by any laboratory. It follows that any collective quantum operation upon  $N$  qubits can be carried out with each laboratory sharing no more than 2 ebits of entanglement, and able to exchange no more than 2 classical bits each way, with the rest of the network. The reasoning which led us to inequalities (2.4-2.6) then implies that no operation can be used to establish more than 2 ebits of pure bipartite entanglement, or be used to exchange more than 2 classical bits each way, between any particular laboratory and the rest of the network.

The maximum total entanglement that can be established is then obtained by multiplication of 2 ebits by the number of laboratories and then dividing by 2, since entanglement is shared, giving

$$E_C \leq N. \quad (3.7)$$

The maximum number of classical bits that any collective operation can be used to communicate is obtained by multiplying the maximum amount of information that one laboratory can communicate, namely 2 bits, by  $N$ , the number of laboratories, giving

$$C_C \leq 2N. \quad (3.8)$$

These bounds are tight, that is, they can be accessed by a specific class of quantum operations, the permutation operations.

A unitary permutation operator upon  $N$  qubits is described by

$$U_P |\psi_1\rangle \otimes \dots \otimes |\psi_N\rangle = |\psi_{P(1)}\rangle \otimes \dots \otimes |\psi_{P(N)}\rangle, \quad (3.9)$$

where  $P(i)$  represents a permutation of the index  $i \in [1, N]$ . Here, we consider only permutation operations which satisfy  $P(i) \neq i \forall i \in [1, N]$ .

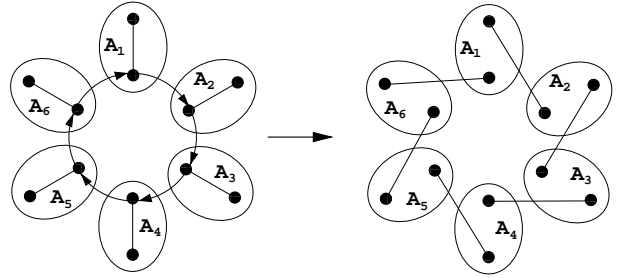

FIG. 8. Illustration of the production of  $N$  ebits of entanglement by the permutation operation. Here,  $N = 6$  and the permutation takes  $\{1, 2, 3, 4, 5, 6\}$  to  $\{6, 1, 2, 3, 4, 5\}$ . One qubit of each initial local ebit is transferred to the successive laboratory, resulting in the final  $N$  shared ebits.

To see that  $N$  ebits of entanglement can be established using a permutation operation, suppose that  $A_i$  contains one local ebit, in the form of, for example, some standard Bell state. We shall denote this state by  $|B^{i,i}\rangle$ . The first and second indices denote the laboratories which possess the first and second qubits respectively. Suppose now that the second qubits' states are permuted according to Eq. (3.9). This transforms  $|B^{i,i}\rangle$  into  $|B^{i,P(i)}\rangle$ . Following this permutation, laboratories  $A_i$  and  $A_{P(i)}$  share the Bell state  $|B^{i,P(i)}\rangle$ . There are  $N$  laboratories, and so  $N$  shared ebits of entanglement in the form of Bell states have been established. This procedure is illustrated in figure (8).

To see that a permutation operation can be used to communicate  $2N$  classical bits, suppose that  $A_{P^{-1}(i)}$  shares the Bell state  $|B^{i,P^{-1}(i)}\rangle$  with  $A_i$ . Locally, using superdense coding,  $A_{P^{-1}(i)}$  can manipulate the state of the second qubit in this Bell state so that it becomes any of the four possible Bell states. Figure (9) illustrates this scenario, where each second qubit is represented by a hollow circle. We may therefore write the state following this local manipulation as  $|B_{\mu(i)}^{i,P^{-1}(i)}\rangle$ , where the integer  $\mu(i) \in [1, \dots, 4]$ . The permutation operation is then carried out on the set of locally-manipulated qubits, resulting in  $A_i$  being in possession of the state  $|B_{\mu(i)}^{i,i}\rangle$ . By performing a Bell measurement,  $A_i$  can read the two bits of information sent by  $A_{P^{-1}(i)}$ , and in total  $2N$  bits have been communicated.

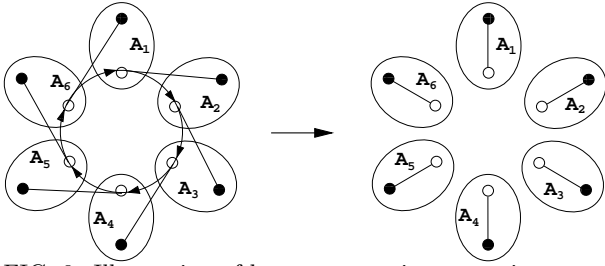

FIG. 9. Illustration of how permutation operations can be used to communicate  $2N$  classical bits, using the same cyclic permutation as in figure (8). Each laboratory initially shares 1 ebit with its successor, which it then manipulates into one of the 4 Bell states. The manipulated qubits are represented by hollow circles. The permutation operation is then used to localise each of these ebits in the successive laboratories. Individual local Bell measurements are performed upon these, each of which reveals two classical bits, or  $2N$  bits in total.

As is the case with the SWAP operation for 2 qubits, the number of ebits that  $U_P$  can establish is also the minimum amount of entanglement required to carry out this operation. The same is true of the classical communication resources involved. Suppose that  $A_i$  shares one ebit of entanglement with  $A_{P(i)}$  and can communicate 2 classical bits to this location. Then the permutation operation can be carried out using these resources to teleport the state of qubit  $q_i$  from  $A_i$  to  $A_{P(i)}$ . Permutation operations, including the SWAP operation, make maximally efficient use of the resources required to carry them out.

As is also the case with the SWAP operation, any operation which is equivalent to  $U_P$  up to an  $N$ -partite local unitary transformation, that is, any unitary operation  $T$  of the form

$$T = \left( \bigotimes_{i=1}^N U_i^2 \right) U_P \left( \bigotimes_{j=1}^N U_j^1 \right), \quad (3.10)$$

where  $U_i^1, U_j^2$  are arbitrary local unitary operations on qubits  $q_i$  and  $q_j$ , is also maximally-inseparable. This is a consequence of the fact that  $U_P$  can be obtained from  $T$  by the local unitary operation

$$U_P = \left( \bigotimes_{i=1}^N U_i^{2\dagger} \right) T \left( \bigotimes_{j=1}^N U_j^{1\dagger} \right). \quad (3.11)$$

Comparing (3.7) and (3.8) with (3.6), we see that the total amount of entanglement that can be established, and the total amount of classical information that can be sent is strictly less than that required to carry out an arbitrary operation using the teleportation protocol, with the exception of the case  $N = 2$ . We have not, however, established the optimality of the teleportation protocol. We examine this issue in the following section.

## IV. RESOURCES REQUIRED TO PERFORM ARBITRARY MULTIPARTICLE OPERATIONS

### A. Graph Symmetrisation

The teleportation-based method for performing an arbitrary collective quantum operation upon  $N$  spatially separated qubits requires  $E_R = 2(N - 1)$  ebits of entanglement and  $C_R = 4(N - 1)$  classical bits. An obviously important question is: are these figures optimal, in the sense that no less entanglement and communication will suffice?

Unlike the case of  $N = 2$ , for general  $N$  we cannot answer this question by making use of the fact that the resource entanglement and communication required by the teleportation protocol can respectively be recovered and used to communicate messages, as can be done with the SWAP operation. For  $N > 2$ , the values of  $E_R$  and  $C_R$  for the teleportation protocol, given by Eq. (3.6), are strictly greater than the upper bounds on  $E_C$  and  $C_C$  in (3.7) and (3.8). Another approach must be taken to resolve this issue. In this section, we show that, for even  $N$ , the resource entanglement and communication required to perform an arbitrary quantum operation upon  $N$  qubits using the teleportation protocol are indeed the minimum possible values. We describe a novel proof technique, which we term *graph symmetrisation*, to establish this fact. The same method is then used to find lower bounds on the minimum values of  $E_R$  and  $C_R$  for odd  $N$ . We find that, for  $N \geq 4$ , these lower bounds are strictly greater than the upper bounds on  $E_C$  and  $C_C$  in Eqs. (3.7) and (3.8).

The problem we will investigate is the following. A network of laboratories  $A_i$  possesses shared bipartite entanglement, described by the graph  $G_E$ , and facilities enabling limited classical communication between them, described by a graph  $G_C$ . If these graphs describe sufficient resources to enable any collective operation to be performed upon their respective resident qubits  $q_j$ , then what lower bounds must the corresponding values of  $E_R$  and  $C_R$  satisfy?

We commence by making the following observation: if the graphs  $G_E(V)$  and  $G_C(V)$  describe sufficient resources, then so does any other pair of graphs obtained from them by a permutation of the vertices. Note that we have written the dependence of the graphs on the vertex set explicitly here. This makes sense intuitively. Nevertheless, here we provide a short proof. Let  $G'_E(V)$  and  $G'_C(V)$  be the entanglement and communication graphs obtained from  $G_E(V)$  and  $G_C(V)$  by a permutation  $P$  of the vertex set. We may write  $G'_E(V) = G_E(P[V])$  and  $G'_C(V) = G_C(P[V])$ , where  $P[V]$  is the permutation. The reversibility of permutation operations implies that  $G_E(V) = G'_E(P^{-1}[V])$  and  $G_C(V) = G'_C(P^{-1}[V])$ . Consider now a quantum operation  $\mathcal{L}$  on the  $N$  qubits. This also depends on the vertex set and so we write it as  $\mathcal{L}(V)$ . We can obtain another quantum operation  $\mathcal{L}'$

from  $\mathcal{L}$  by applying the same permutation to the vertex set, that is,  $\mathcal{L}'(V) = \mathcal{L}(P[V])$ , and  $\mathcal{L}(V) = \mathcal{L}'(P^{-1}[V])$ .

If there exists an operation  $\mathcal{L}'(V)$  which cannot be performed using the resources described by the graphs  $G'_E(V)$  and  $G'_C(V)$ , then by reversing the permutation  $P$ , it follows that  $\mathcal{L}(V)$  cannot be carried out using  $G_E(V)$  and  $G_C(V)$ , in contradiction with our premise. Thus, if the resources described by the graphs  $G_E(V)$  and  $G_C(V)$  can be used to carry out any quantum operation, then so do those described by  $G_E(P[V])$  and  $G_C(P[V])$  for any permutation  $P$  of the vertex set  $V$ .

Let us now consider the graphs  $\tilde{G}_E$  and  $\tilde{G}_C$ , defined by

$$\tilde{G}_E = \sum_{P[V]} G_E(V), \quad (4.1)$$

$$\tilde{G}_C = \sum_{P[V]} G_C(V). \quad (4.2)$$

These graphs are constructed by summing over all of the graphs obtained from  $G_E$  and  $G_C$  by permuting the vertices. By summing, we mean summing the entanglement and communication represented by the weights of the edges. The resource entanglement and communication matrices for these graphs are easily obtained. Their elements are

$$\tilde{E}_R^{ij} = \sum_{P[V]} E_R^{P(i),P(j)}, \quad (4.3)$$

$$\tilde{C}_R^{ij} = \sum_{P[V]} C_R^{P(i),P(j)}. \quad (4.4)$$

These graphs are regular and complete. A complete graph is one where each pair of vertices is joined by an edge. In the case of the graph  $\tilde{G}_C$ , this means that each pair of vertices is connected by an edge in each direction. A regular graph is one where all edges have the same weight. In a network represented by these graphs, all pairs of laboratories share the same amount of entanglement, and can communicate the same amount of classical information, in both directions.

For the purposes of illustration, the graphs  $\tilde{G}_E$  and  $\tilde{G}_C$  are shown in figures (10) and (11) corresponding to the particular graphs  $G_E$  and  $G_C$  in figures (4) and (5).

The regularity and completeness properties are easily proven, and follow immediately from the fact that the graphs  $\tilde{G}_C$  and  $\tilde{G}_E$ , being defined as sums over all vertex permutations, are clearly themselves permutation invariant.

The total resource entanglement and communication for these graphs,  $\tilde{E}_R$  and  $\tilde{C}_R$ , are easily evaluated in terms of the corresponding resources represented by the original graphs  $G_E$  and  $G_C$ . Take the case of  $\tilde{E}_R$ : there are  $N!$  permutations of the vertex set, so  $\tilde{G}_E$  describes  $N!$  times as much entanglement as  $G_E$ , that is

$$\tilde{E}_R = N!E_R. \quad (4.5)$$

Similarly,

$$\tilde{C}_R = N!C_R. \quad (4.6)$$

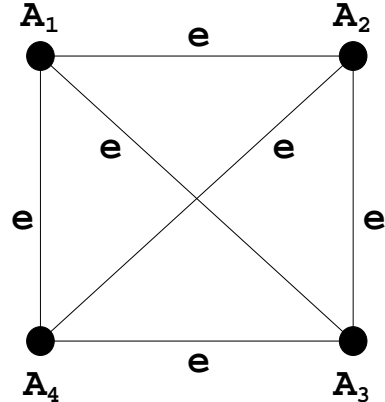

FIG. 10. Symmetrised resource entanglement graph  $\tilde{G}_E$  corresponding to the graph  $G_E$  in figure (4). Here,  $e$ , which is given by eq. (4.7), is equal to 24.

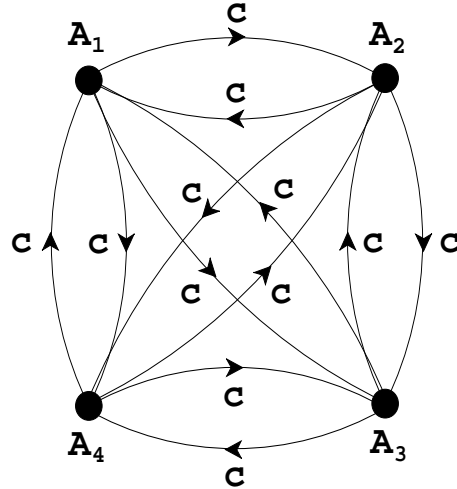

FIG. 11. Symmetrised resource communication graph  $\tilde{G}_C$  corresponding to the graph  $G_C$  in figure (5). Here,  $c$ , which is given by Eq. (4.8), is equal to 42.

All edges in each of these graphs have the same weight, and it will be convenient to label these two weights. For  $\tilde{G}_E$  and  $\tilde{G}_C$ , we denote these edge weights simply by  $e$  and  $c$  respectively. These are

$$e = 2(N-2)!E_R, \quad (4.7)$$

$$c = (N-2)!C_R, \quad (4.8)$$

which follows from Eqs. (4.5) and (4.6), and also from the fact that the graphs  $\tilde{G}_E$  and  $\tilde{G}_C$  have  $N(N-1)/2$  and  $N(N-1)$  edges respectively. For the graphs in figures (10) and (11), we find that  $e = 24$  and  $c = 42$ .

There are  $N!$  permutations of the vertex set. The permutation invariance of the sufficiency condition then implies that the resources represented by the graphs  $\tilde{G}_E$

and  $\tilde{G}_C$  can be used to perform any operation  $N!$  times. By this, we mean the following: suppose that  $A_i$  contains  $N!$  qubits. We can then define  $N!$  sets of qubits, where each contains one qubit from each laboratory. It will be possible to perform the same operation separately upon every one of these sets.

In the next two subsections, we will use the formalism developed here, together with inequalities (2.4-2.6) to establish lower bounds on the values of  $e$  and  $c$ . These lead to lower bounds on  $E_R$  and  $C_R$  through Eqs. (4.7) and (4.8). We shall treat the cases of even and odd  $N$  separately, since, for even  $N$ , it is possible to use this technique to solve for the minimum values of  $E_R$  and  $C_R$  which are sufficient to carry out any operation. These are those required to implement the teleportation protocol described in section III.

### B. Necessary and Sufficient Resources for Even $N$

Using the formalism we have set up, we can obtain the minimum values of  $E_R$  and  $C_R$  exactly when  $N$  is even. The network of  $N$  laboratories is assumed to possess sufficient resources, described by the graphs  $\tilde{G}_E$  and  $\tilde{G}_C$ , to enable any operation to be carried out  $N!$  times. Here, we consider one particular operation, which we will refer to as the pairwise-SWAP (PS) operation. This operation has the effect of swapping the state of a qubit at  $A_j$  with that of one at  $A_{j+1}$ , for all odd  $j$ . If we write the two-particle SWAP operation exchanging the states of qubits at  $A_j$  and  $A_{j+1}$  as  $U_S^{j+1,j}$ , then the PS operation may be written as

$$U_{PS} = U_S^{N,N-1} \otimes U_S^{N-2,N-3} \otimes \dots \otimes U_S^{2,1}. \quad (4.9)$$

This operation is illustrated in figure (12).

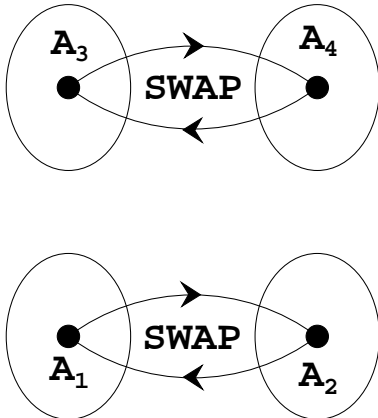

FIG. 12. Depiction of the pairwise-SWAP (PS) operation for  $N = 4$ .

The PS operation is a permutation operation which leaves no vertex invariant, and so it can be used to es-

tablish  $N$  ebits of entanglement and to communicate  $2N$  classical bits. Performing this operation  $N!$  times can then be used to create  $N!N$  ebits of entanglement and to send  $2N!N$  bits of classical information. From the assumption that the graphs  $\tilde{G}_E$  and  $\tilde{G}_C$  represent sufficient resources to carry out the  $N!$ -fold PS operation, we can deduce the minimum values of  $e$  and  $c$ , and using Eqs. (4.7) and (4.8), those of  $E_R$  and  $C_R$ , required to do so.

To determine the minimum value of  $e$ , we will make use of the fact that entanglement cannot increase under LQCC operations. Consider the situation depicted in figure (13). We partition the entire network into two sets. One contains the even laboratories  $A_2, A_4, \dots, A_N$ , and the other contains the odd ones  $A_1, A_3, \dots, A_{N-1}$ . We shall refer to these sets as  $S_{even}$  and  $S_{odd}$ .

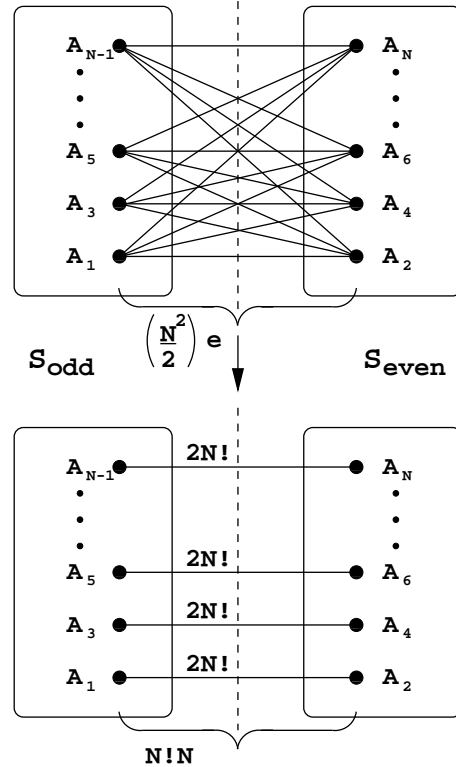

FIG. 13. Use of the resource entanglement graph  $\tilde{G}_E$  to carry out the  $N!$ -fold pairwise-SWAP operation. Initially, the entanglement resources are distributed according to the graph  $\tilde{G}_E$ . We have divided the  $N$  laboratories into even and odd sets  $S_{even}$  and  $S_{odd}$ . For the sake of clarity, we have not indicated the internal entanglement of these sets. Each laboratory in  $S_{odd}$  shares  $e$  ebits of entanglement with each laboratory in  $S_{even}$ . These sets are separated by an imaginary partition, indicated by the broken line. Initially, these sets share  $(N/2)^2 e$  ebits, and the  $N!$ -fold PS operation can create  $N!N$  ebits. The total entanglement shared across this partition cannot increase, and the requirement that  $e$  must be large enough to carry out the  $N!$ -fold PS operation leads to inequalities (4.10) and (4.11).

The total entanglement initially shared by these sets can be calculated in a straightforward manner. Each of the  $N/2$  laboratories in  $S_{odd}$  shares  $e$  ebits with each laboratory in  $S_{even}$ , that is,  $Ne/2$  ebits with  $S_{even}$  in total. Adding up the  $N/2$  such contributions from the laboratories in  $S_{odd}$  gives  $(N/2)^2 e$  ebits initially shared by  $S_{even}$  and  $S_{odd}$ . The final entanglement they share is  $N!N$  ebits. The total entanglement that  $S_{even}$  and  $S_{odd}$  share cannot increase, giving the inequality

$$\left(\frac{N}{2}\right)^2 e \geq N!N. \quad (4.10)$$

Making use of Eq. (4.7), we find that

$$E_R \geq 2(N-1). \quad (4.11)$$

This lower bound on the total resource entanglement is precisely the amount which is required by the teleportation protocol. Thus, for even  $N$ , the teleportation protocol is optimal with regard to the required total resource entanglement.

This bound has been derived on the basis of the fact that, in a multipartite system, the (bipartite) entanglement shared by two exhaustive subsets cannot increase under LQCC operations. Although the entanglement initially shared by each pair of laboratories is in pure, bipartite form, the transformation shown in figure (13) may, at some point, manipulate the resource entanglement into, possibly mixed, multipartite entanglement. Our argument still holds under these circumstances. If the final entanglement is in multipartite form, then in order to carry out the  $N!$ -fold PS operation,  $A_j$  and  $A_{j+1}$  will have to be able to *distill*  $2N!$  ebits of pure, bipartite entanglement. The *total* distillable entanglement between  $S_{even}$  and  $S_{odd}$  cannot increase, which leads to inequality (4.10) and thus the teleportation bound in (4.11).

The nonincreasing of entanglement under LQCC operations is an asymptotic result. It follows that the teleportation protocol is asymptotically optimal for even  $N$ . By asymptotic [22], we mean that, given a very large number of sets of separated qubits, where the same, arbitrary operation is to be carried out on each set, the teleportation protocol uses the minimum *average* entanglement that is required per run of the operation.

In practical situations, it is often the resources required to carry out an operation successfully just once that will be of interest. For general information processing tasks, the resources required in the ‘one-shot’ scenario are at least equal to the resources required asymptotically. For the problem we have considered here, when  $N$  is even, the entanglement resources required in both scenarios are equal. This is because the teleportation protocol, which requires  $2(N-1)$  ebits, can be used to carry out any collective operation on  $N$  qubits once.

The proof that the  $N$  laboratories must also be able to send  $4(N-1)$  classical bits proceeds similarly. The graph  $\tilde{G}_C$  is assumed to represent sufficient CC resources to

perform any operation  $N!$  times. If this operation is the PS operation, then it should then be able to communicate  $2N!N$  bits. Given this, and the fact that each laboratory can communicate  $c$  classical bits to each other one, we can determine the minimum value of  $c$ , from which we can infer the minimum of  $C_R$  through Eq. (4.8).

Again, we partition the vertex set into  $S_{even}$  and  $S_{odd}$ . According to inequalities (2.4-2.5), the total amount of resource communication between the sets  $S_{even}$  and  $S_{odd}$  cannot be less than the amount of classical information that the  $N!$ -fold PS operation can be used to communicate between these two sets.

According to  $\tilde{G}_C$ , each of the  $N/2$  laboratories in  $S_{even}$  can communicate  $c$  classical bits to each one in  $S_{odd}$ . From this, we find that the maximum amount of classical information that can be sent in either direction between  $S_{even}$  to  $S_{odd}$  odd is  $(N/2)^2 c$  bits.

The  $N!$ -fold PS operation can be used to send  $N!N$  bits in either direction  $S_{even}$  to  $S_{odd}$ . Inequalities (2.4-2.5) imply that

$$\left(\frac{N}{2}\right)^2 c \geq N!N. \quad (4.12)$$

Making use of Eq. (4.8), we obtain

$$C_R \geq 4(N-1), \quad (4.13)$$

which is the amount of resource communication required to implement the teleportation protocol. We have thus shown that, in terms of the total resource entanglement and communication, the teleportation protocol in section III is maximally efficient.

### C. Necessary Resources for Odd $N$

Let us now examine the case of odd  $N$ . We have been unable to find a specific operation which proves that the minimum resources required to carry out any operation on an odd number of qubits are those employed by the teleportation protocol. However, using the graph symmetrisation technique, it is still possible to obtain lower bounds on these minimum resources. As before, we assume that the graphs  $\tilde{G}_E$  and  $\tilde{G}_C$  represent sufficient resources to perform any operation  $N!$  times. The specific operation we shall consider here is the PS operation upon the first  $N-3$  qubits, and a separate, cyclic permutation of the remaining three. For  $N=3$ , there is only this latter part of the operation. We shall refer to this as the PS+CP operation, and it is illustrated in figure (14).

The PS+CP operation is again a permutation operation which leaves no vertex invariant. It follows that it can be used to establish  $N$  ebits of entanglement and to communicate  $2N$  classical bits.

We shall now apply the same arguments as those used for the PS operation for even  $N$  to obtain lower bounds

on the resources required to carry out the PS+CP operation. Again, we divide the  $N$  laboratories into two sets,  $S_{even}$  and  $S_{odd}$ .

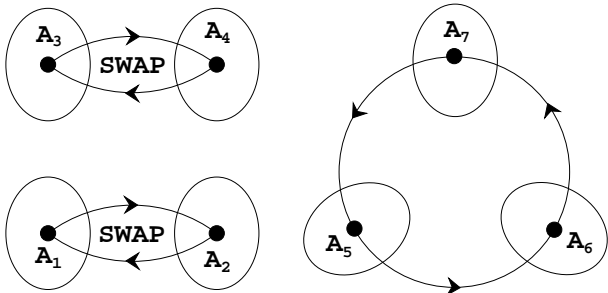

FIG. 14. Depiction of the PS+CP operation for  $N = 7$

Our aim, as before, is to obtain lower bounds on the minimum values of  $c$  and  $e$  from the assumption that  $\tilde{G}_E$  and  $\tilde{G}_C$  represent sufficient resources to perform this particular operation  $N!$  times.

We begin by deriving a lower bound on the minimum sufficient resource entanglement  $E_R$ . In figure (15), the total initial entanglement between  $S_{even}$  and  $S_{odd}$  is depicted, as is the amount of entanglement that can be established by the  $N!$ -fold PS+CP operation. As before, these sets are divided by an imaginary partition, and the total entanglement across this partition cannot increase.

Initially, each of the  $(N - 1)/2$  laboratories in  $S_{even}$  shares  $e$  ebits with each of the  $(N + 1)/2$  laboratories in  $S_{odd}$ . The total amount of entanglement initially shared by  $S_{even}$  and  $S_{odd}$  is then  $(N^2 - 1)e/4$  ebits. There are two contributions to the amount of entanglement that can be created by the  $N!$ -fold PS+CP operation. One is that created by the PS part of the operation on the qubits in the first  $N - 3$  laboratories. This can create  $N!(N - 3)$  ebits. The second contribution comes from the cyclic permutation on the remaining three laboratories. This gives an additional  $2N!$  ebits. Inequality (2.6) then implies

$$\left(\frac{N^2 - 1}{4}\right) e \geq N!(N - 1). \quad (4.14)$$

Making use of Eq. (4.8), we obtain a corresponding lower bound on  $E_R$ :

$$E_R \geq 2 \left(\frac{N}{N + 1}\right) (N - 1), \quad (4.15)$$

that is, the teleportation bound multiplied by a factor of  $N/(N + 1)$ . The argument given for even  $N$  that this bound cannot be improved upon by converting the initial bipartite resource entanglement into multiparticle entanglement also applies here.

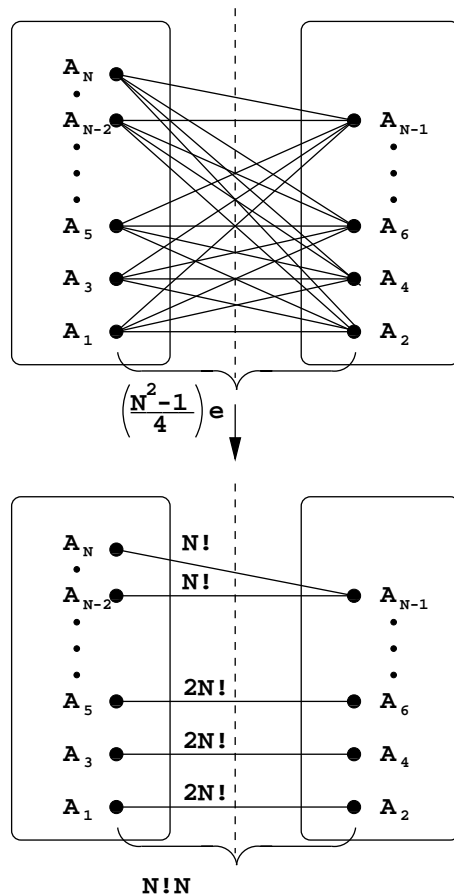

FIG. 15. Use of the resource entanglement graph  $\tilde{G}_E$  to carry out the  $N!$ -fold PS+CP operation. The initial entanglement resources are distributed according to the graph  $\tilde{G}_E$ . Here, prior to carrying out the operation, the sets  $S_{even}$  and  $S_{odd}$  share  $(N^2 - 1)e/4$  ebits of entanglement. The  $N!$ -fold PS+CP operation can establish  $N!N$  ebits between them. The total entanglement shared by these sets cannot increase, and the requirement that  $e$  must be large enough to carry out the  $N!$ -fold PS+CP operation leads to inequalities (4.14) and (4.15).

Let us now obtain a lower bound on the minimum resource communication  $C_R$ . As with the even case, we will make use of the fact that the amount of classical information that the PS+CP operation can be used to communicate, in either direction between  $S_{even}$  and  $S_{odd}$ , cannot exceed the amount of resource communication in this direction that must be consumed in order to implement the  $N!$ -fold PS+CP operation.

For the sake of concreteness, we shall consider communication from  $S_{even}$  to  $S_{odd}$ . Initially, each of the  $(N - 1)/2$  laboratories in  $S_{even}$  can communicate  $c$  classical bits to each of the  $(N + 1)/2$  laboratories in  $S_{odd}$ . This implies that the total resource communication from  $S_{even}$  to  $S_{odd}$  is  $(N^2 - 1)c/4$  bits. It is easy to show that it is the same in the opposite direction.

As with entanglement, the PS and CP parts of the  $N!$ -fold PS+CP operation make distinct contributions to the amount of information that this operation can be used to send from  $S_{even}$  to  $S_{odd}$ . For a single implementation of PS+CP, the PS part can communicate  $(N-3)$  bits from  $S_{even}$  to  $S_{odd}$ , while the CP part can be used to send 2 bits. Thus, the total amount of classical information that the  $N!$ -fold PS+CP operation can be used to send in either direction across the partition is  $N!(N-1)$  bits.

The impossibility of this exceeding the resource communication in either direction across the partition implies that

$$\left(\frac{N^2-1}{4}\right) c \geq N!(N-1). \quad (4.16)$$

and, making use of Eq. (4.8), we obtain the corresponding bound for  $C_R$ :

$$C_R \geq 4 \left(\frac{N}{N+1}\right) (N-1), \quad (4.17)$$

which, like the entanglement bound in (4.15), is the teleportation bound multiplied by  $N/(N+1)$ .

Like the bounds in (4.11) and (4.13) for the even case, the lower bounds we have obtained here for the minimum resource entanglement and communication for odd  $N$  are asymptotic results. However, the fact that the bounds (4.15) and (4.17) are not integers suggests that if the available resources are at these bounds, they may not be very useful in the one-shot case, where it is more desirable to be able to transmit whole bits of classical information, and to manipulate whole ebits of entanglement. With this in mind, let us return to the bound on  $E_R$  in (4.15) and consider the inequality

$$\frac{2N(N-1)}{N+1} = 2(N-1) - 2 + \frac{4}{N+1} \geq 2(N-1) - 2 \quad (4.18)$$

where the equality is attained only in the limit as  $N \rightarrow \infty$ . If we are to round this bound up to the next integer, we obtain  $2(N-1) - 1$ . Thus, the minimum number of integer ebits able to carry out an arbitrary operation on an odd number of qubits, in the one-shot case, is bounded from below by one ebit less than the teleportation bound.

By a similar calculation, one can show, using the bound in (4.17), that in the one-shot case, if classical information is to be transmitted in integer amounts, then the minimum number of bits needed to carry out an arbitrary operation on an odd number of qubits is bounded from below by 3 bits less than the teleportation bound. For  $N = 3, 5$ , a stronger bound of 2 bits less than resource communication for the teleportation protocol is obtained.

With these observations in mind, the case of  $N = 3$  appears to be particularly significant. For this case, in the one-shot scenario, we see that at least 3 ebits and

6 classical bits are required. However, we know that a permutation of 3 qubits can create 3 ebits or be used to send 6 classical bits. This implies that these bounds must also hold asymptotically.

It is important to compare the bounds in (4.15) and (4.17), which hold rigorously in both the one-shot and asymptotic scenarios, with the maximum amount of entanglement that can be created, and the maximum amount of classical information that can be sent, by an  $N$  qubit operation. With this in mind, we note the following inequality, which holds for all  $N \geq 3$ :

$$2 \left(\frac{N}{N+1}\right) (N-1) \geq N. \quad (4.19)$$

The equality is obtained only when  $N = 3$ . This implies that, for all  $N \geq 4$ , the resources required to carry out an arbitrary operation exceed those that can be recovered, either by re-establishing consumed entanglement, or using the resource communication which was consumed to implement the operation to send useful messages.

As we saw in section II, this is not the case for  $N = 2$ , which can be seen from the properties of the SWAP operation. The remaining case, that of  $N = 3$ , is presently unsolved.

#### D. Transfer of Expendable Resources

In our derivation of the lower bounds on the minimum resource entanglement and communication needed to carry out any multiqubit operation, we used specific operations where certain pairs of laboratories needed to be able to establish large amounts of entanglement or communicate large amounts of classical information: more than is represented by the corresponding edges in the graphs  $\tilde{G}_E$  and  $\tilde{G}_C$ . Thus, to carry out either the  $N!$ -fold PS or PS+CP operation, the resources from the other edges in these graphs must somehow be ‘transferred’ to the edges which must gain resources.

We can formalise this notion in the following way: consider a multiqubit operation  $\mathcal{L}$  on  $N$  qubits. If  $\mathcal{L}$  is carried out  $N!$  times, then depending on the initial conditions, there may be some pairs of laboratories which will end up sharing more than  $e$  ebits of entanglement, or exchanging more than  $c$  classical bits in either, or perhaps both directions. Let us define the *target* entanglement and communication graphs  $G_E^T$  and  $G_C^T$ . These will represent either the number of ebits shared by each pair of laboratories or the number of classical bits communicated, following the  $N!$ -fold implementation of  $\mathcal{L}$ . These graphs can be characterised by the target entanglement and communication matrices  $\mathbf{E}_T = \{E_T^{ij}\}$  and  $\mathbf{C}_T = \{C_T^{ij}\}$ , in the same way as for the resource graphs.

For  $\tilde{G}_E$  and  $G_E^T$ , we will define a pair of complementary subsets of the edge set,  $S_{E+}$  and  $S_{E-}$ , in the following way:  $S_{E+}$  is the subset of the edge set, where each edge is denoted by the unordered pair  $(i, j)$ , such that  $E_T^{ij} > e$ .

The set  $S_{E-}$  contains all edges for which  $E_T^{ij} \leq e$ . These sets contain the edges which respectively gain, and do not gain entanglement.

Similarly, for the classical communication graphs  $\tilde{G}_C$  and  $G_C^T$ , we will define the subsets  $S_{C+}$  and  $S_{C-}$  of the edge set.  $S_{C+}$  contains the edges, represented by *ordered* pairs  $[i, j]$ , for which  $C_T^{ij} > c$ , and  $S_{C-}$  contains all edges  $[i, j]$  for which  $C_T^{ij} \leq c$ .

Here, we shall be particularly interested in the edges which gain resources. In fact, the resources contained in the other edges, contained in the sets  $S_{E-}$  and  $S_{C-}$ , will be considered *expendable*. The total expendable entanglement and communication are given by

$$E_E = \frac{1}{2} \sum_{(i,j) \in S_{E-}} \tilde{E}_R^{ij}, \quad (4.20)$$

$$C_E = \sum_{[i,j] \in S_{C-}} \tilde{C}_R^{ij}. \quad (4.21)$$

The question we would like to answer is: how much of the expendable entanglement or communication can be transferred to the set  $S_{E+}$  or  $S_{C+}$ ? We have been unable to obtain the general solution to this problem, although the analysis of the PS operation suggests intuitively appealing upper bounds.

For the  $N!$ -fold PS operation, the values of  $E_E$  and  $C_E$  are easily calculated, where the sets  $S_{E+}$  and  $S_{C+}$  contain the edges linking laboratories whose qubits are to be swapped. We find that

$$E_E = \frac{1}{2}(N^2 - 2N)e, \quad (4.22)$$

$$C_E = (N^2 - 2N)c. \quad (4.23)$$

If each pair of swapped qubits generates 2 ebits of entanglement, then as we know, the  $N!$ -fold PS operation can be used to create  $N!N$  ebits. The total amount of entanglement which has been *added* to the set  $S_{E+}$  is then  $N!N - (Ne/2)$  ebits. From inequality (4.10), we see that

$$N!N - \frac{Ne}{2} \leq \frac{E_E}{2} \quad (4.24)$$

that is, at most half of the expendable entanglement can be added to the edges in  $S_{E+}$ . Whether or not this bound holds in general for all  $N$ , and when the initial resource entanglement is not described by a regular, complete graph, is currently unknown. However, we can prove that it holds in general for  $N = 3$ . Consider 3 laboratories,  $A_1 \dots A_3$ . Let their initial and final entanglement be described by the resource and target entanglement graphs  $G_E$  and  $G_T^T$ , characterised by the corresponding matrices  $\mathbf{E}_R$  and  $\mathbf{E}_T$ . The difference between the initial and final entanglement between each pair of laboratories can be represented by the matrix  $\mathbf{\Delta} = \mathbf{E}_T - \mathbf{E}_R$ .

The fact that the total amount of entanglement shared by one laboratory and the other pair cannot increase implies that the sum of the elements in each row or column of  $\mathbf{\Delta}$  cannot exceed zero. This also implies that

the entanglement between at most one pair of laboratories can increase. Let this pair of laboratories be  $A_1$  and  $A_2$ . Summing up the elements of  $\mathbf{\Delta}$  in rows 1 and 2, together with the nonincreasing property of the column sums, gives  $\Delta_{12} \leq |\Delta_{13} + \Delta_{23}|/2$ . The numerator on the right hand side is the total amount of entanglement lost. We see that the entanglement transferred to the edge (1,2) cannot exceed half of this loss.

This kind of entanglement loss was originally discovered in association with *entanglement swapping* [14]. It would be useful to know whether or not it is an unavoidable feature of all operations which transfer entanglement, and for an arbitrary number of spatially separated systems. Any proof, or disproof, of this conjecture must take into account the possibility that the initial bipartite resource entanglement is converted into multiparticle entangled states. Some progress has recently been made towards developing a theory of conversion between bipartite and multiparticle entangled states [23]. The study of certain particular situations has indicated that these conversions are typically lossy. Consequently, we do not believe that multiparticle entangled states will enable more efficient entanglement transfer.

Returning to the  $N!$ -fold PS operation, we will show how a similar result relating the expendable communication to the communication that can be added to the edges in  $S_{C+}$  can be obtained. The  $N!$ -fold PS operation can be used to send  $2N!N$  bits. The total amount of communication which has been *added* to the set  $S_{C+}$  is then  $2N!N - Nc$  bits. From inequality (4.12), we see that

$$N!N - \frac{Nc}{2} \leq \frac{C_E}{2} \quad (4.25)$$

that is, at most half of the expendable communication can be added to the edges in  $S_{C+}$ .

This restriction holds in general if the expendable communication is used to transmit information *indirectly* between pairs of laboratories. By ‘indirectly’, we mean the following. the weight of an edge in a resource communication graph is equal to the number of bits that one party can transmit along a channel to some other party, without passing through some intermediate laboratory. Clearly, the sender can transmit more information to the receiver if he sends some information via some intermediate laboratories. By indirect communication, we mean this relaying procedure.

Thus, if the sender wishes to send  $\kappa$  bits indirectly, he will use up at least  $\kappa$  bits of resource communication sending this information to the intermediate parties, who will in turn use up at least a further  $\kappa$  bits of resource communication relaying it to the receiver. So, the  $\kappa$  bits actually communicated from sender to receiver cannot exceed the lower bound of  $2\kappa$  bits depleted from the resource communication.

For the remainder of this section, we will make the hypothesis that at most half of the expendable resources can be transferred is of general validity, and explore its



consequences for odd  $N$  and the PS+CP operation. We will show that this leads to tighter bounds than (4.15) and (4.17) on the amount of resource entanglement and communication needed to carry out an arbitrary operation on an odd number of qubits.

Let us return to the  $N!$ -fold PS+CP operation. Beginning with entanglement, the amount of entanglement transferred to the edges in  $S_{E+}$  has two contributions. The entanglement transferred by the PS part of the operation is easily calculated to be  $(N-3)(2N!-e)/2$  ebits. The amount transferred by the CP part is  $3(N!-e)$  ebits. The expendable entanglement is that initially represented by all other edges in the graph  $\tilde{G}_E$ , and is found to be

$$E_E = \left[ \frac{N^2}{2} - N - \frac{3}{2} \right] e. \quad (4.26)$$

The assumption that at most half of the expendable entanglement can be transferred to the edges in  $S_{E+}$  leads to the inequality

$$N!N \leq e \left[ \frac{N-3}{2} + 3 \right] + \frac{E_E}{2}. \quad (4.27)$$

From the relationship between  $e$  and the initial resource entanglement  $E_R$ , expressed in Eq. (4.7), we find

$$E_R \geq \frac{2(N-1)}{1+3/N^2}. \quad (4.28)$$

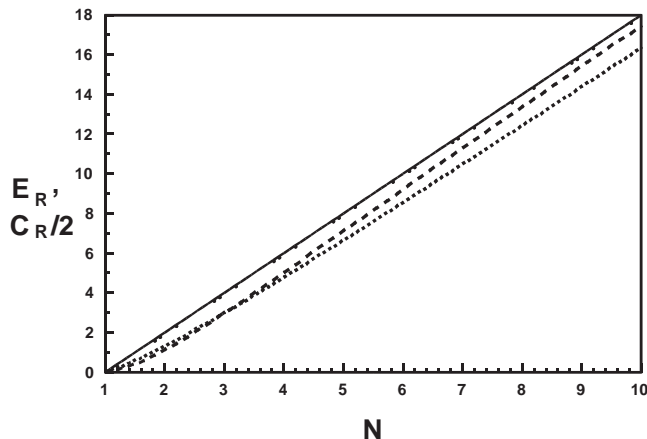

FIG. 16. Lower bounds on the resource entanglement and communication versus the number of qubits. The solid line corresponds to the teleportation bound in (4.11) and (4.13). The dotted line indicates the bounds in (4.15) and (4.17) for the PS+CP operation which hold rigorously for odd  $N$ . The dashed line corresponds to the bounds in (4.28) and (4.29), for the PS+CP operation and odd  $N$  if at most half of the expendable resources can be transferred.

Similar reasoning can be applied to the required minimum classical communication. If at most half of the expendable communication is transferable, then the minimum number of classical bits required to perform the PS+CP operation with odd  $N$  is bounded by

$$C_R \geq \frac{4(N-1)}{1+3/N^2}. \quad (4.29)$$

Assuming that inequalities (4.28) and (4.29) hold, let us deduce the minimum integer resources for the one shot case, as we did in the previous subsection. To this end, we note the inequality

$$\frac{2(N-1)}{1+3/N^2} \geq 2(N-1) - 1, \quad (4.30)$$

for  $N \geq 3$ , with the equality only being attained when  $N = 3$ . From this inequality, we see that for all  $N \geq 4$ , the minimum integer resource entanglement is equal to that required to implement the teleportation protocol. By a similar calculation, one can show that for all  $N > 3$ , the minimum integer resource communication is at least equal to one bit short of the teleportation bound, and that for all  $N \geq 12$ , it is the teleportation bound.

Figure (16) illustrates the main asymptotic bounds we have considered in this paper: the teleportation bound, the bound derived from the PS+CP operation derived in the previous subsection and the bound derived from the PS+CP operation based on the assumption that only half of the expendable resources are transferable.

To summarise this subsection, we have worked on the assumption that at most half of the expendable resources can be transferred. The analysis of the PS operation supports this conjecture that it is true for all  $N$ . If it indeed is true in general, then in the one-shot case, the teleportation protocol is optimal with regard to the resource entanglement for all odd  $N \neq 3$ , and also in terms of the resource communication for all odd  $N \geq 13$ , if only integer resources are permitted.

## V. DISCUSSION.

In this paper, we have examined the properties of collective quantum operations performed upon spatially separated quantum systems. We have considered a network of  $N$  spatially separated laboratories, each of which contains one qubit. The network is equipped with facilities for classical communication and local quantum operations, and each pair of laboratories also shares bipartite pure entanglement.

This scenario we have considered helps to emphasise the fact that the final state of each system will depend upon the initial states of the others. The evolution thus requires information to be exchanged between the systems. In classical physics, this is simply classical information. If the systems are quantum mechanical, then the exchange of quantum information is necessary.

The transmission of quantum information from one location to another can be achieved by sending quantum systems, or by quantum teleportation. We have proposed a simple teleportation-based protocol which allows any quantum operation to be performed upon  $N$  separated, identical quantum systems. Teleportation requires

the transmission of classical information and existence of entanglement shared between the sending and receiving stations. In the case of  $N = 2$ , one particular class of operations, namely those equivalent, up to bipartite local unitary transformations, to the SWAP operation, permits either the minimum classical communication or entanglement resources required to perform any operation to be ‘recovered’ for other tasks. These operations may be regarded as the most inseparable operations for  $N = 2$ .

For  $N > 2$ , the situation is more interesting. For  $N \geq 4$ , no operation can establish the entanglement or be used to communicate the information necessary to perform any operation. Whether or not this is also the case for  $N = 3$  is currently unknown. For all  $N$  we have determined the maximum total amount of entanglement that can be established, and the maximum total number of classical bits that can be communicated, by any operation. Permutation operations attain these limits, which are also the minimum resources required to carry out these specific operations.

We have also examined the problem of finding the minimum resources required to perform an arbitrary operation. The scenario we considered was one where each pair of laboratories shares a certain amount of entanglement, and can communicate a certain number of classical bits to each other. The problem we addressed was: what are the minimum values of the total entanglement and communication required to carry out an a priori unknown operation, that is, unknown prior to the entanglement and communication resources being set up?

For even  $N$ , we have found these minimum resources exactly, and these can be used to perform an arbitrary operation using teleportation. We arrived at these bounds using a technique we refer to as graph symmetrisation. We have shown that the teleportation protocol is optimal for even  $N$ . Whether or not it is also optimal for odd  $N$  is an important outstanding problem. We have shown, in the even case, that the optimality of the teleportation protocol can be reinterpreted as coming from a restriction on the extent to which expendable resources can be transferred from one pair of laboratories to another. In particular, for any amount of resources transferred, at least as much are irrevocably lost. The assumption that this restriction always holds leads to tighter bounds on the resources required to carry out an arbitrary operation on an odd number of qubits. These bounds imply that if, in the one shot scenario, resources can only be consumed in integer amounts, then the teleportation protocol is optimal, for all  $N > 3$  for entanglement and for all  $N \geq 12$  for communication also. One clear conclusion from our work is that the case of  $N = 3$  is of particular interest, since many of our results which apply to all other  $N \neq 2$  have not been established for this case. It could be that graph-theoretic techniques are not suitable for analysing the 3 qubit case, and that other tools must be employed.

## ACKNOWLEDGEMENTS.

We would like to thank Sandu Popescu, Noah Linden, Osamu Hirota and Masahide Sasaki for interesting discussions. We also wish to thank John Vaccaro for help with some of the figures. Part of this work was carried out at the Japanese Ministry of Posts and Telecommunications Communications Research Laboratory, Tokyo, and we would like to thank Masayuki Izutsu for his hospitality. This work was funded by the UK Engineering and Physical Sciences Research Council, and by the British Council.

- 
- [1] J. S. Bell, *Speakable and Unsayable in Quantum Mechanics: Collected Papers on Quantum Philosophy* (Cambridge 1987).
  - [2] C. H. Bennett, G. Brassard, C. Crepeau, R. Josza, A. Peres and W. K. Wootters, *Phys. Rev. Lett.* **70**, 1895 (1993).
  - [3] P. W. Shor, *SIAM Journal on Computing* **26**(5), 1484 (1997).
  - [4] L. K. Grover, *Phys. Rev. Lett* **79**, 325 (1997).
  - [5] A. K. Ekert, *Phys. Rev. Lett.* **67**, 661 (1991).
  - [6] S. Popescu and D. Rohrlich, *Phys. Rev. A* **56**, 3319 (1997).
  - [7] B. Schumacher, *Phys. Rev. A* **51**, 2738 (1995).
  - [8] H. Barnum, E. Knill and M. A. Nielsen, ‘On Quantum Fidelities and Channel Capacities’, LANL e-print quant-ph/9809010.
  - [9] S. Lloyd, *Phys. Rev. A* **56**, 1613 (1997).
  - [10] B. Schumacher, *Phys. Rev. A* **54**, 2614 (1996).
  - [11] A. Chefles, C. R. Gilson and S. M. Barnett, ‘Entanglement and Collective Quantum Operations’, LANL eprint quant-ph/0003062, *Phys. Lett. A*, in press.
  - [12] W. K. Wootters, *Phys. Rev. Lett.* **80** 2245 (1998).
  - [13] C. H. Bennett, G. Brassard, S. Popescu, B. Schumacher, J. A. Smolin and W. K. Wootters, *Phys. Rev. Lett.* **76** 722 (1996).
  - [14] M. Zukowski, A. Zeilinger, M. A. Horne and A. K. Ekert, *Phys. Rev. Lett.* **71** 4287 (1993).
  - [15] K. Kraus, *States, Effects and Operations: Fundamental Notions of Quantum Theory*, (Springer-Verlag, Berlin Heidelberg, 1983).
  - [16] J. Eisert, K. Jacobs, P. Papadopoulos and M. B. Plenio, ‘Optimal Local Implementation of Non-Local Quantum Gates’, LANL eprint quant-ph/0005101.
  - [17] M. Horodecki and R. Horodecki, *Phys. Lett. A* **244**, 473 (1998).
  - [18] D. Collins, N. Linden and S. Popescu, ‘The Non-Local Content of Quantum Operations’, LANL eprint quant-ph/0005102.
  - [19] A. Chefles and S. M. Barnett, *Phys. Lett. A* **232** (1997) 4.
  - [20] C. H. Bennett and S. Wiesner, *Phys. Rev. Lett.* **69**, 2881

(1992).

- [21] See any introductory text for a fuller discussion, e.g. R. Gould, *Graph Theory*, (Benjamin/Cummings 1988).
- [22] C. H. Bennett, H. J. Bernstein, S. Popescu and B. Schumacher, *Phys. Rev. A* **53** 2046 (1996).
- [23] N. Linden, S. Popescu, B. Schumacher and M. Westmoreland, 'Reversibility of Local Transformations of Multiparticle Entanglement', LANL e-print quant-ph/9912039.