

UDK 669.187:669.788
Professional article/Strokovni članekISSN 1580-2949
MTAEC9, 43(4)219(2009)STEEL REFINING IN A VACUUM UNIT WITH
CHEMICAL BOOSTINGRAFINACIJA JEKLA V VAKUUMSKI NAPRAVI Z VPIHOVANJEM
LEGIRNIH DODATKOV¹Zdeněk Adolf, ¹Miroslav Dostál, ²Zdeněk Šána¹ VŠB-Technical University of Ostrava, Faculty of Metallurgy and Materials Engineering, 17. listopadu 15/2172, 708 33 Ostrava-Poruba, Czech Republic² EVRAZ Vítkovice Steel, a. s., 708 33 Ostrava, Czech Republic
zdenek.adolf@vsb.cz

Prejem rokopisa – received: 2008-10-13; sprejem za objavo – accepted for publication: 2009-04-15

This paper describes an integrated system of secondary metallurgy (ISSM), which is exploited at the company EVRAZ Vítkovice Steel a.s. Ostrava Czech Republic. The system consists of a caisson-type vacuum unit, enabling chemical boosting, decarburisation, desulphurisation, chemical homogenisation and the modification of a liquid steel's chemical composition simultaneously in two ladles. The experimental part was focused on observation and evaluation with a statistical analysis of the parameters, which influence substantially the final hydrogen content after a vacuum treatment of steel. The most important of the monitored parameters appeared to be the vacuum treatment time, the sulphur content in the refined steel and the difference between initial and final temperatures of the steel in the ISSM.

Keywords: vacuum refining of steel, ladle with chemical boosting, reduction of hydrogen content

V članku je opisan integrirani sistem za sekundarno metalurgijo (ISSM), ki je v uporabi v podjetju EVRAZ Vítkovice Steel, Ostrava, Češka Republika. Sistem sestavljajo vakuumska posoda, v kateri je mogoče legiranje dodatkov, razožgijčenje, razžveplanje, kemična homogenizacija in sprememba kemične sestave taline v dveh ponovcah istočasno. Eksperimentalno delo je bilo namenjeno spremljanju in statistični analizi parametrov, ki pomembno vplivajo na vsebnost vodika po vakuumski obdelavi jeklene taline. Največji vpliv je bil ugotovljen pri trajanju vakuumske obdelave, končni vsebnost žvepla in razliki med začetno in končno temperaturo procesa v ISSM.

Ključne besede: vakuumska rafinacija jekla, ponovca z legiranjem, zmanjšanje vsebnosti vodika

1 INTRODUCTION

In 2007 the company EVRAZ Vítkovice Steel put into operation the integrated system of secondary metallurgy (ISSM). The equipment enables chemical boosting, vacuum treatment, degassing, decarburisation, desulphurisation, temperature and chemical homogenisation and modification of the chemical composition of molten steel simultaneously in two ladles.

2 EQUIPMENT ISSM

The basic part of the ISSM technological equipment consists of a caisson, which contains a refining ladle with molten steel stirred by an inert gas. The design of the equipment is shown in **Figure 1**.

After the insertion of the ladle, the caisson is hermetically closed and the treatment of hot metal begins. The evaluation of the technological parameters of the ISSM is shown in **Figure 2**. **Figure 3** shows a timeline of the metallurgical parameters of the molten steel during its refining.

3 EXPERIMENTAL PART

The steel manufactured in a bottom blown converter OBM is characterised by an increased content of hydrogen. Therefore, the objective of the experimental work

was to evaluate the connection of the measured parameters in terms of the final content of hydrogen during the steel's treatment in the vacuum unit. The investigated X70 steel is intended for large-diameter welded tubes used for long-distance ducts. The required chemical composition is given in **Table 1**.

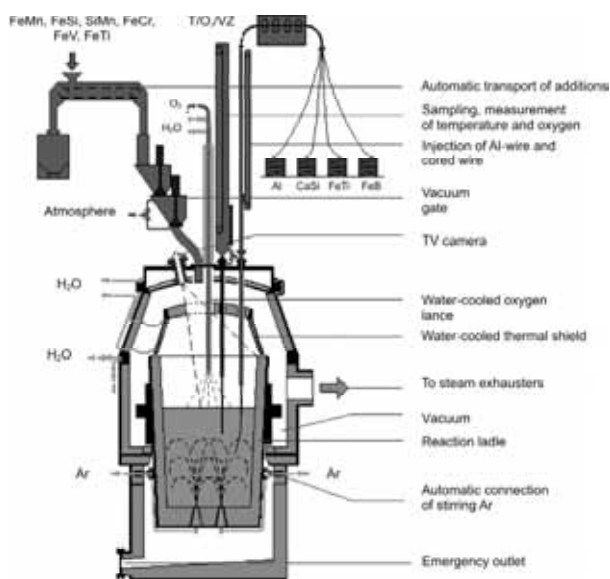

Figure 1: Design of the ISSM vacuum unit
Slika 1: Shema vakuumske naprave ISSM

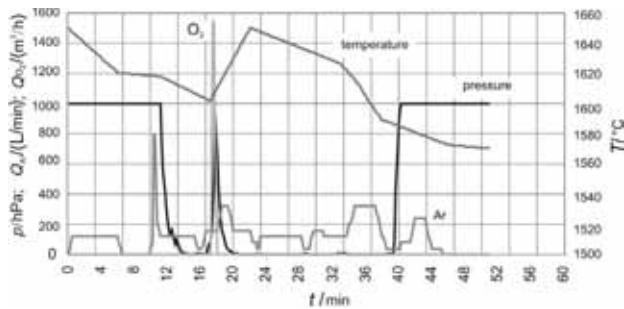

Figure 2: Technological parameters of the ISSM processing
Slika 2: Tehnološki parametri procesiranja v ISSM

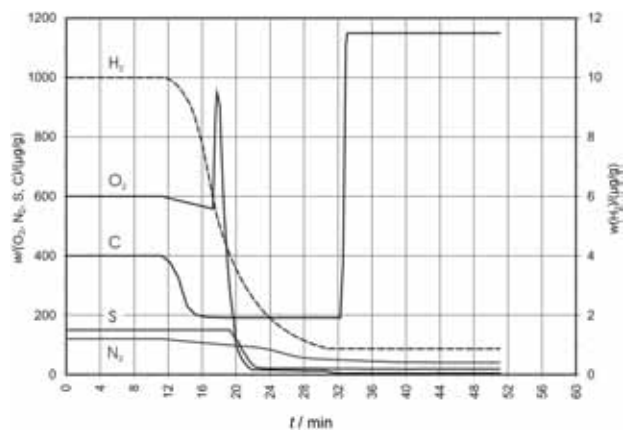

Figure 3: Metallurgical parameters of the ISSM processing
Slika 3: Metalurški parametri procesiranja ISSM

The evaluation of partial influences of the individual parameters on the hydrogen content of steel was made by the method of pairing linear regression. The evaluated

Table 1: Chemical composition of the steel X70 in mass fractions (w%)
Tabela 1: Kemična sestava jekla X 70 (w%)

X 70	C	Mn	Si	P	S	Cu	Ni	Cr	V	Ti	Al	N	Nb
min											0.020		0.03
max	0.11	1.80	0.40	0.018	0.006	0.30	0.30	0.30	0.08	0.035	0.050	0.010	0.06

Table 2: Table of variable values
Tabela 2: Tabela z vrednostmi spremenljivk

		Minimum	Maximum	Average	Unit
Regressor	Hydrogen content	1.2	2	1.58	μg/g
Regressor	Duration of vacuum treatment	525	1595	937.1	s
	Temperature of steel at the beginning of the treatment (ISSM)	1589	1624	1605.5	°C
	Temperature of steel at the end of the treatment (ISSM)	1557	1576	1564.5	°C
	Difference between the initial and final temperatures of the steel (ISSM)	28	55	40.9	°C
	Sulphur content in steel during tapping from the converter in mass fractions (w)	0.0047	0.012	0.008	%
	Sulphur content in steel at the end of the treatment (ISSM) in mass fractions (w)	0.0011	0.0038	0.002	%
	Mass of charged ferro-alloys	20	214	100	kg
	Difference between overall time of treatment and duration of vacuum treatment in ISSM	16.5	38	23.9	min
Regressor	Sulphur content in ISSM in mass fractions (w)	0,0011	0,0038	0,002	%
Regressor	Duration of vacuum treatment	525	1595	937,1	s

data were obtained from heat sheets. The variables, their maximum, minimum and average values, are given in Table 2.

The extent of the impact of the independent variable (regressant) on the hydrogen content in the steel (regressor) was evaluated with the help of:

- the correlation coefficient (R), characterising closeness of dependence,
- the slope of a straight line, which was recalculated to an angle, which is formed by the straight line with the axis x (α), characterising the closeness of the dependence,
- the testing parameter (P), the values of which should be lower than 0.05.

In order to obtain a comparison of the slope of the dependence characterising the intensity of the effect of the given parameter on the hydrogen content, the values of the regressant were re-calculated to a dimensionless form in the interval from 0 to 1 using the equation

$$\bar{x}_i = \frac{x_i - x_{\min}}{x_{\max} - x_{\min}}$$

where x_i is the concrete value of the parameter, \bar{x}_i is the re-calculated value of the parameter, 1, x_{\max} , x_{\min} are the maximum and minimum values of the parameter.

The results of the regression statistics are given in Table 3.

3.1 Evaluation of the results of the regression analysis

From Table 3 it follows that the final content of hydrogen in the steel is, as expected, influenced mostly

Table 3: Parameters of evaluated dependencies for hydrogen and sulphur on different variables**Tabela 3:** Parametri ocenjenih odvisnosti za vodik in žveplo od različnih spremenljivk

	R	P	α
Hydrogen content			
Duration of the vacuum treatment	0.381	0.0005	-20°
Temperature of steel at the beginning of the treatment (ISSM)	0.204	0.071	-9.8°
Temperature of steel at the end of the treatment (ISSM)	0.031	0.791	-1.5°
Difference between the initial and final temperatures of the steel (ISSM)	0.2725	0.0172	-13.8°
Sulphur content in steel during tapping from the converter	0.220	0.050	10.6°
Sulphur content in steel at the end of the treatment (ISSM)	0.3304	0.0031	15.6°
Mass of charged ferro-alloys	0.216	0.120	9.2°
Difference between the overall time of the treatment and the duration of the vacuum treatment in ISSM	0.1466	0.2094	7.4°
Sulphur content in ISSM			
Duration of vacuum treatment	0.4477	0.00001	-26.8°

by the vacuum treatment time (**Figure 4**). A higher initial temperature of the steel, which accelerates the diffusion of hydrogen in the melt, also has a positive influence. While the temperature of steel at the end of treatment in the ISSM has no influence (it must correspond exactly to the specified temperature of the

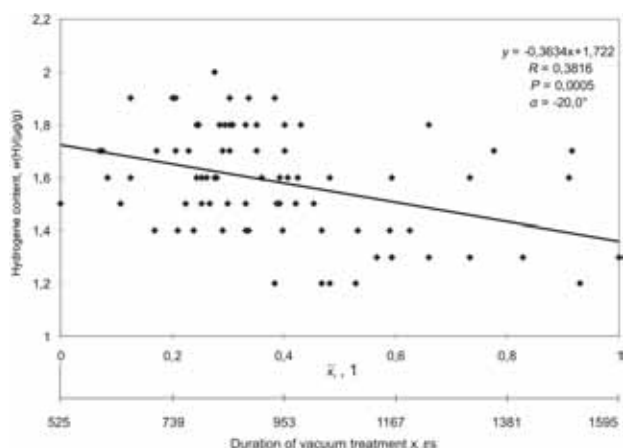
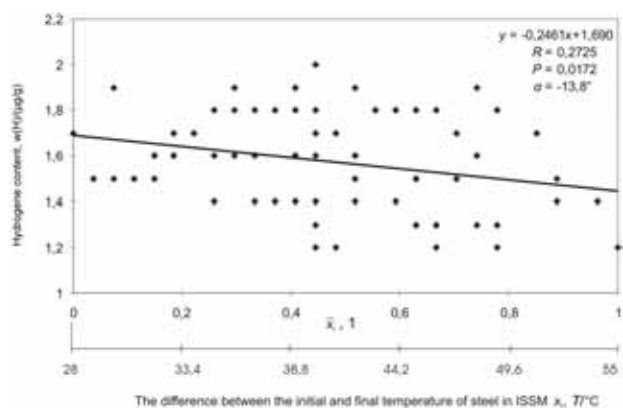
**Figure 4:** Dependence of hydrogen content on the vacuum treatment time**Slika 4:** Odvisnost med vsebnostjo vodika in trajanjem vakuumiranja**Figure 5:** Dependence of the hydrogen content on the difference between the initial and final temperatures of the steel in the ISSM**Slika 5:** Odvisnost vsebnosti vodika od razlike med začetno in končno temperaturo jekla v ISSM

casting on the CCM), the difference between the initial and final temperatures of the steel in the ISSM shows a substantial influence on the reduction of the hydrogen content (**Figure 5**).

It is evident from **Figures 6 and 7** that the final content of hydrogen is closely related to the sulphur content in the steel. This is explained by the surface activity of the sulphur, which prevents the transfer of hydrogen into the gaseous phase. The higher slope and the closeness of the dependence in **Figure 7** shows that the negative influence of sulphur on the degassing is already evident at low contents of sulphur at the end of the vacuum treatment. At the beginning of the steel treatment in the ISSM, the steel contains, apart from sulphur, also surface-active oxygen, which also restricts the de-sulphurisation. However, its content was not monitored.

Ferro-alloys containing humidity are always a source of hydrogen. The mass of ferro-alloys shows the comparatively insignificant influence on the final content of hydrogen due to the intensive vacuum treatment.

The intensive contact of steel with slag during argon blowing into the melt also causes deep desulphurisation, which is evident from **Figure 8**.

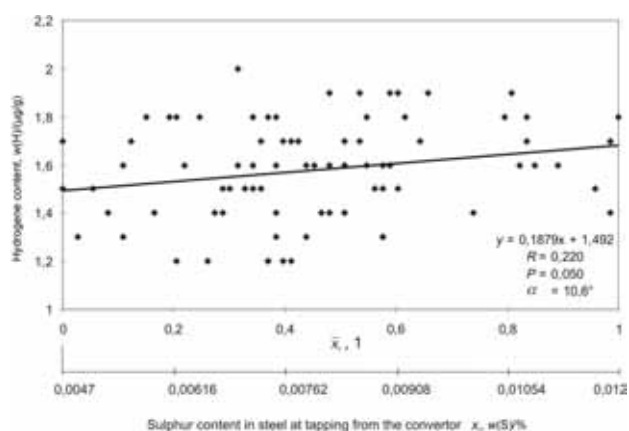
**Figure 6:** Dependence of hydrogen content on the sulphur content in steel during tapping from the converter**Slika 6:** Odvisnost vsebnosti vodika od vsebnosti žvepla ob izlivu jekla iz konvertorja

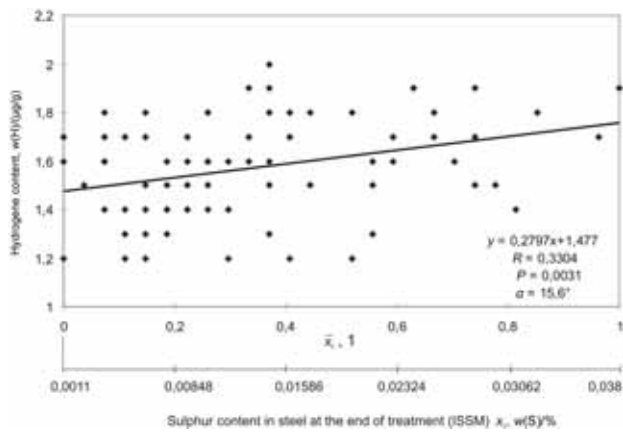

Figure 7: Dependence of the hydrogen content on the sulphur content in the ISSM

Slika 7: Odvisnost vsebnosti vodika od vsebnosti žvepla v ISSM

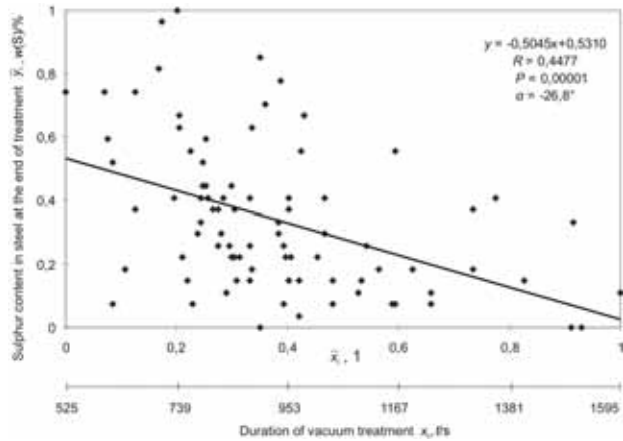

Figure 8: Dependence of the sulphur content on the vacuum treatment time

Slika 8: Odvisnost vsebnosti žvepla od trajanja vakuuiranja

The positive value of the slope in **Figure 9** (the dependence of hydrogen content on the time of vacuum treatment and argon blowing of the steel only) shows that during the time of argon blowing and alloying the hydrogen content increases.

4 CONCLUSION

The aim of the work was to compare the influence of selected parameters on the final content of hydrogen during steel refining in the ISSM vacuum unit. The investigation was made on this equipment installed in the company EVRAZ Vitkovice Steel. The experimental findings of the tests are as follows:

- the greatest effect on the final hydrogen content in steel after treatment in the ISSM is found for the vacuum treatment time. This dependence shows both significant closeness and slope;
- the increased initial temperature of the steel in the ISSM has a positive influence on the hydrogen

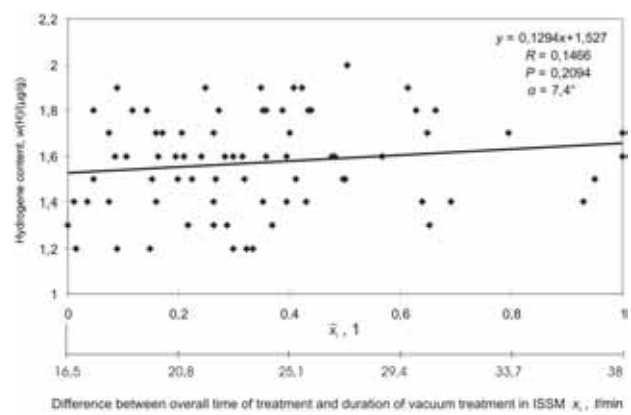

Figure 9: Dependence of the hydrogen content on the time when the steel is not vacuum treated in the ISSM

Slika 9: Odvisnost vsebnosti vodika od časa prepihanja z argonom brez vakuuiranja

diffusivity and, therefore, also a positive influence on steel degassing;

- the final temperature of the steel after treatment in the ISSM has no influence on the degassing efficiency, since, it is specified in a very narrow interval depending on the casting temperature of the given grade on the CCM;
- the mass of ferro-alloys showed a certain influence on the final hydrogen content in the steel, but it was less significant than the effect of the vacuum treatment time;
- the content of sulphur influences significantly the final hydrogen content in the steel because of its high surface activity;
- from the comparison of the dependence of the hydrogen content on the duration of the vacuum treatment and argon treatment it was found that during the time when the steel was argon treated only, the degassing is almost arrested;
- the influence of the vacuum treatment time on the reduction of sulphur content was found to be important. Although the vacuum does not affect the desulphurisation, the increase of the intensity of the stirring of the steel and the slag as a result of argon blowing into the vacuum-treated steel has significantly reduced the content of sulphur.

The work was undertaken within the frame of the project EUREKA 3580! and the project FI-IM4/110 with the financial support of the Ministry of Education, Youth and Sports and Ministry of Industry and Trade of the Czech Republic.

5 REFERENCES

- ¹ Dostál, M. Pánvová pec ISSM – hodnocení vybraných parametrů taveb [Ladle furnace ISSM – evaluation of selected parameters of heats]. Bachelor degree thesis, VŠB-TU Ostrava, 2008, 40 pp.