

## Carbon-coated magnetic particles increase tissue temperatures after laser irradiation

Shupeng Liu<sup>\*,†,‡</sup>, Na Chen<sup>\*</sup>, Fufei Pang<sup>\*</sup>, Zhengyi Chen<sup>\*</sup>  
and Tingyun Wang<sup>\*</sup>

*\*Key Laboratory of Specialty Fiber Optics and Optical Access Networks  
Shanghai University, 149 Yanchang Road  
Shanghai 200072, P. R. China*

*†Institute of Biomedical Engineering, Shanghai University  
149 Yanchang Road, Shanghai 200072, P. R. China  
‡liusp@shu.edu.cn*

Received 4 August 2014  
Accepted 4 November 2014  
Published 2 December 2014

**Purpose:** This work focused on the investigation the hyperthermia performance of the carbon-coated magnetic particles (CCMPs) in laser-induced hyperthermia. **Materials and methods:** We prepared CCMPs using the organic carbonization method, and then characterized them with transmission electron microscopy (TEM), ultraviolet-visible (UV-Vis) spectrophotometry, vibrating sample magnetometer (VSM) and X-ray diffraction (XRD). In order to evaluate their performance in hyperthermia, the CCMPs were tested in laser-induced thermal therapy (LITT) experiments, in which we employed a fully distributed fiber Bragg grating (FBG) sensor to profile the tissue's dynamic temperature change under laser irradiation in real time. **Results:** The sizes of prepared CCMPs were about several micrometers, and the LITT results show that the tissue injected with the CCMPs absorbed more laser energy, and its temperature increased faster than the contrast tissue without CCMPs. **Conclusions:** The CCMPs may be of great help in hyperthermia applications.

**Keywords:** Carbon-coated magnetic particles; hyperthermia; laser.

### 1. Introduction

Magnetic nanoparticles have been widely used to improve the quality of magnetic resonance imaging, drug delivery, cell separation and hyperthermia applications.<sup>1-3</sup> Many kinds of magnetic nanoparticles

have been prepared, such as ultra-small superparamagnetism iron oxide particles and carbon-coated magnetic nanoparticles.<sup>4-7</sup>

Hyperthermia is a therapeutic procedure that raises the temperature of a region of the body

<sup>‡</sup>Corresponding author.

This is an Open Access article published by World Scientific Publishing Company. It is distributed under the terms of the Creative Commons Attribution 3.0 (CC-BY) License. Further distribution of this work is permitted, provided the original work is properly cited.

affected by cancer. The elevated temperature can be produced by various methods, such as microwave, ultrasound, laser or a magnetic field.<sup>8</sup> Hyperthermia combined with radiation treatment, chemotherapy or photodynamic therapy may improve the efficacy of cancer therapies.<sup>9–13</sup> Some studies found that injecting nanoparticles into the tumor also improved the cancer treatment.<sup>14,15</sup> Nanoparticles, such as gold nanoparticles or gold nanorods, have been shown to strongly increase the absorption of laser light, which helps target the heat to the tumor cells.<sup>16,17</sup> Some studies have demonstrated that iron oxide magnetic nanoparticles and carbon nanotubes can effectively mediate hyperthermia.<sup>18–21</sup> Carbon-coated magnetic particles (CCMPs) also absorb a significant amount of laser light, and they therefore may mediate hyperthermia as well as magnetic particles, or carbon nanotubes.

Fiber Bragg grating (FBG) are widely used for specific applications in aeronautics, the automotive industry, structure monitoring in civil engineering and undersea oil exploration for the measurement of various parameters such as strain, force, pressure, displacement, temperature, humidity and radiation dose.<sup>22</sup> Recently, FBG has been used in biomedical application such as biomechanics<sup>22,23</sup> and hyperthermia.<sup>24,25</sup> FBG could measure multi-point temperature, and this would be helpful for the temperature detection and control to avoid the normal cells from being damaged during cancer hyperthermia. In this paper, we prepared the CCMPs and investigated their performance in mediating laser-induced hyperthermia by using the FBG as a fully distributed temperature sensor to measure the temperature distribution in tissues.

## 2. Materials and Methods

### 2.1. Preparing CCMPs

We used the organic carbonization method<sup>26</sup> to prepare CCMPs. Iron (III) nitrate nonahydrate ( $\text{Fe}(\text{NO}_3)_3 \cdot 9\text{H}_2\text{O}$ ) (0.8 g), poly(vinyl alcohol) (PVA) (2.1 g) and poly(vinyl pyrrolidone) (0.2 g) were dissolved into 40 mL water. The solution was heated for about 4 h at 100°C to evaporate the water. Then the solutes were heated to above 400°C with nitrogen for several minutes, producing the CCMPs.

### 2.2. Characterizing CCMPs

Drops of diluted CCMPs solutions were deposited on carbon films supported by copper grids and then air-dried in a ventilation cabinet. A JEM-200CX (JEOL, Japan) transmission electron microscope (TEM) was used to study the particle morphology. The CCMPs powder were characterized by X-ray diffraction (XRD) on a D/MAX-2200 X-ray diffractometer (Rigaku, Japan). Magnetic characterization of CCMPs was carried out using a vibrating sample magnetometer (7407, LakeShore, USA) at room temperature with maximum applied field of 2.3 T. The ultraviolet-visible (UV-Vis) adsorption spectra of CCMPs dispersed in deionized water were collected on a UV-2102PCS UV-Vis spectrophotometer.

### 2.3. Cell and tissue experiments

Human hepatoma cells (SMMC 7721) were cultured in Dulbecco's modified Eagle medium (DMEM) supplemented with 10% heat-inactivated fetal bovine serum (FBS). Cells were maintained under

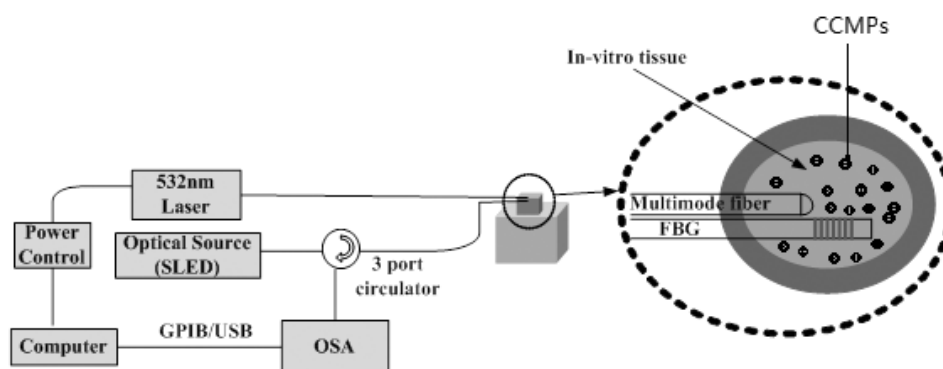

Fig. 1. Schematic of the tissue hyperthermia experiment.

standard cell culture conditions at 37°C with 5% CO<sub>2</sub>. Cells dissociation was processed using 0.25% Trypsin-EDTA, and cells were mixed with the CCMPs when exposed to the laser. The muscle tissue used in this experiment came from pork bought from the supermarket. CCMPs were injected about 10 mm into the muscle tissue.

The solid-state laser (MLL-H-532, Changchun New Industries Optoelectronics Technology Co., Ltd.) with a total power of 900 mW at the wavelength of 532 nm was used in the photothermal treatment. The 532-nm laser was transmitted to the tissue through the multimode fiber, where the output power from the multimode fiber coupled to the sample was about 261 mW. Then, the tissues and the nanoparticles absorbed the laser energy, and their temperature rose subsequently. The temperature detection device with the distributed FBG sensor was designed in our laboratory, and it can detect the temperature dynamically at roughly 8 s intervals, as shown in Fig. 1.

### 3. Results

#### 3.1. Characterizing the CCMPs

The XRD, magnetization curve and TEM image of the CCMPs were measured and analyzed. The results are shown in Figs. 2–4.

The magnetic nanoparticles were dispersed in the carbon, and the mean size of the magnetic nanoparticles was about 15 nm. The average size of the CCMPs was about several micrometers. The XRD spectrum of the CCMPs shows that the magnetic nanoparticles were Fe<sub>3</sub>O<sub>4</sub>, and the estimated

crystallite size was about 9 nm using X-rays data by Jade software. The PVA blocked the crystal development process of Fe<sub>3</sub>O<sub>4</sub>, and the carbon coated on the Fe<sub>3</sub>O<sub>4</sub> weakened the peak of the XRD spectra. The saturation magnetization was about 5.27 emu/g, the carbon may also affect the magnetism of the magnetic particles.

The UV-Vis absorption spectra of CCMP water solutions were shown in Fig. 5, whereby wavelength scanning was performed from 200 nm to 800 nm. Deionized water was used to construct the baseline for the measurement. The results from the UV-Vis absorption spectra imply that CCMPs can absorb about 60% of the laser energy in a 10 mg/mL CCMPs–water solution.

#### 3.2. Cell and tissue experiments

Cells mixed with CCMPs produced higher temperatures of laser irradiation than cells without CCMPs [Fig. 6(a)]. Without cells, the CCMPs solution absorbed more laser power than water (without CCMPs) at the same conditions [Fig. 6(b)]. These results show that CCMPs can absorb laser energy and increase temperatures, so they may be beneficial for laser-induced hyperthermia.

The temperature distribution was measured in the pork muscle tissue under laser-induced hyperthermia (Fig. 7). The highest temperature achieved in the water-injected tissue was about 50°C, whereas that of the CCMP-injected tissue was 60°C. The results show that the tissue injected with CCMPs absorbed more laser energy, and its temperature increased faster than the contrast tissue without CCMPs.

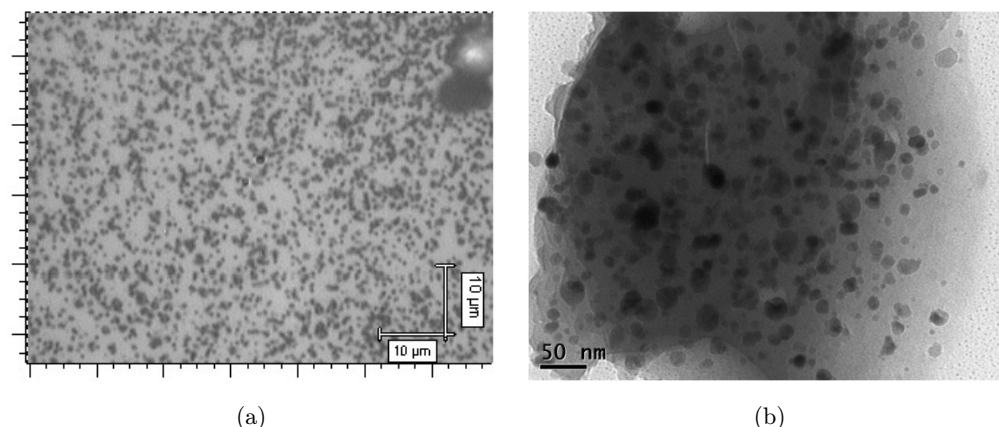

Fig. 2. Images of the CCMPs. (a) Optical images of the CCMPs; (b) TEM images of the CCMPs.

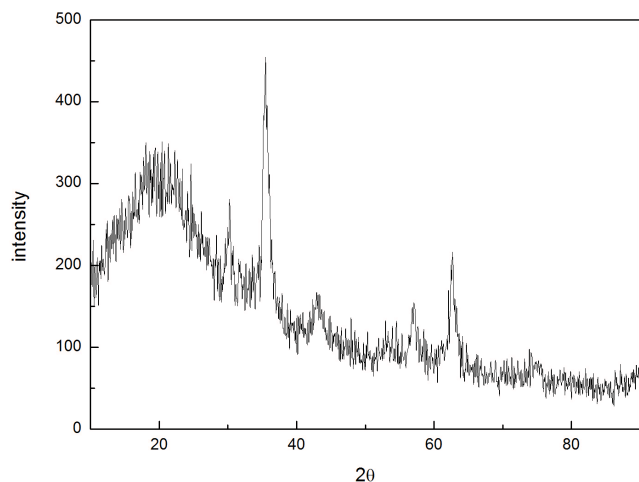

Fig. 3. Powder X-ray diffraction pattern of the CCMPs.

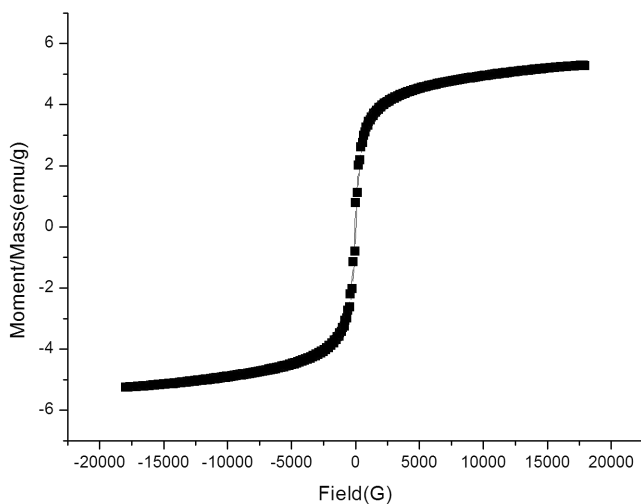

Fig. 4. Magnetization curves of the CCMPs.

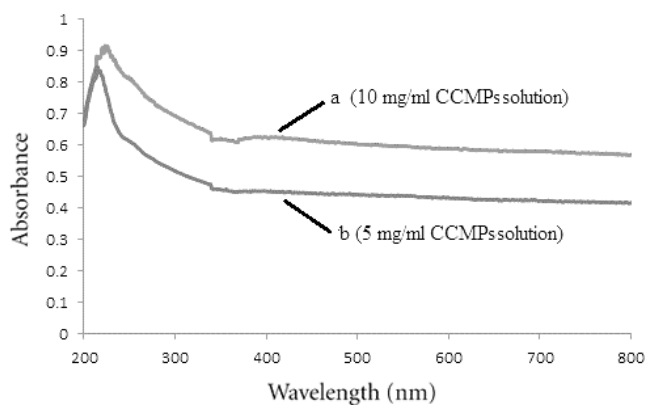
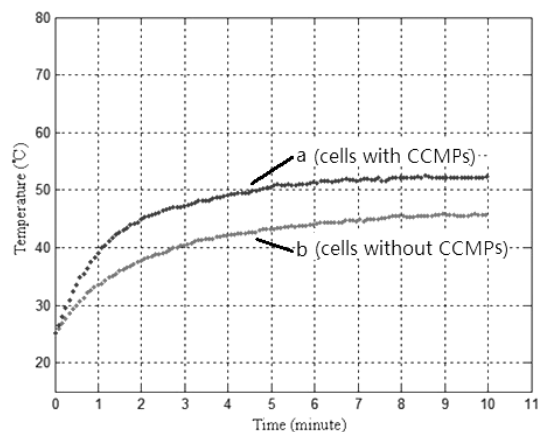
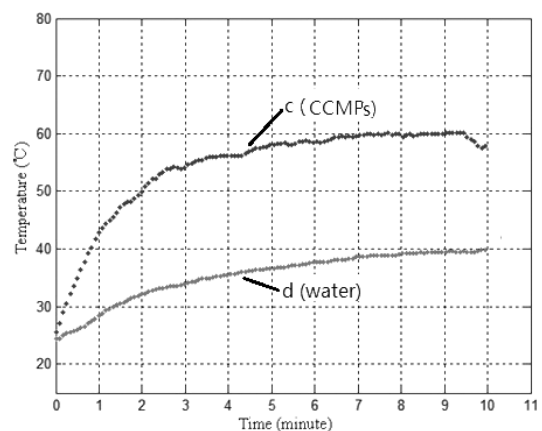

Fig. 5. UV-Vis absorption spectra of CCMPs. (a) 10 mg/mL CCMPs-water solution; (b) 5 mg/mL CCMPs-water solution.



(a)



(b)

Fig. 6. Temperature curves with time as laser irradiation to cells and water. (a) Line a shows the temperature curve of a cell solution mixed with CCMPs (0.2 mL cell + 0.1 mL 0.03 g/mL CCMPs); Line b shows the temperature curve of a cell-only solution (0.2 mL cell + 0.1 mL water). (b) Line c shows the temperature curve of a CCMPs solution (0.3 mL 0.03 g/mL CCMPs); Line d shows the temperature curve of water alone (0.3 mL water).

#### 4. Discussion

The magnetic iron oxide nanoparticles have good biocompatibility and are already used with hyperthermia treatments clinically and in research.<sup>27,28</sup> Consequently, magnetic particles were selected for photoabsorption in laser-induced hyperthermia. Carbon has also been used previously as a photoabsorption material.<sup>18</sup> Therefore, CCMPs were studied as a photoabsorption material for laser-induced hyperthermia in this paper.

The CCMPs were prepared and tested with laser irradiation. We found that water or cell solutions

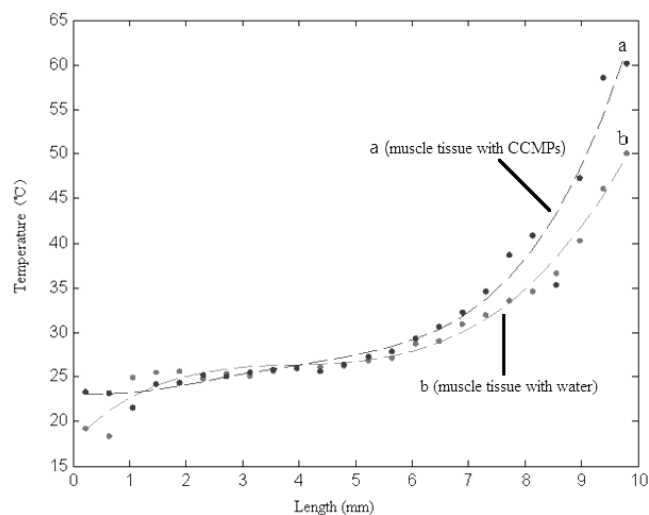

Fig. 7. Temperature profile of the muscle tissue after laser irradiation. (a) muscle tissue with 0.2 mL of a 0.03 g/mL CCMPs solution; (b) Muscle tissue with 0.2 mL water (without CCMPs).

that contained CCMPs absorbed more laser power than water or cell solutions without CCMPs. In addition, CCMPs allowed for higher muscle tissue temperatures than non-CCMP-containing tissue because the particles helped to focus the heat to a specific location. Therefore, when CCMPs are injected into cancerous cells, their “focusing” capability may help prevent healthy tissue from being destroyed when laser-induced hyperthermia is performed in cancer therapy.

Our future work will focus on hyperthermia therapy experiments using CCMPs in a cancerous mouse model. Because CCMPs can absorb laser energy, they may be helpful in cancer hyperthermia therapy.

## Acknowledgments

This work is supported by the Natural Science Foundation of China (NSFC) (61027015, 61177088, 61107076) and the National Program on Key Basic Research Project (973 Program, 2012CB723405). We would like to thank Dr. Bo Lu from the Laboratory for Microstructures for helping us analyze the XRD and magnetism data.

## References

1. A. K. Gupta, M. Gupta, “Synthesis and surface engineering of iron oxide nanoparticles for biomedical applications,” *Biomaterials* **26**, 3995–4021 (2005).

2. D. K. Kim, Y. Zhang, J. Kehr, T. Klason, B. Bjelke, M. Muhammed, “Characterization and MRI study of surfactant-coated superparamagnetic nanoparticles administered into the rat brain,” *J. Magn. Magn. Mater.* **225**, 256–261 (2001).
3. B. Thiesen, A. Jordan, “Clinical applications of magnetic nanoparticles for hyperthermia,” *Int. J. Hyperthermia* **24**(6), 467–474 (2008).
4. C. C. Berry, A. S. G. Curtis, “Functionalisation of magnetic nanoparticles for applications in biomedicine,” *J. Phys. D: Appl. Phys.* **36**, R198–R206 (2003).
5. S. Purushotham, P. E. J. Chang, H. Rumpel, I. H. C. Kee, R. T. Ng, P. K. H. Chow *et al.*, “Thermoresponsive core-shell magnetic nanoparticles for combined modalities of cancer therapy,” *Nanotechnology* **20**(30), 1–11 (2009).
6. R. Nesper, A. Ivantchenko, F. Krumeich, “Synthesis and characterization of carbon-based nanoparticles and highly magnetic nanoparticles with carbon coatings,” *Adv. Funct. Mater.* **16**, 296–305 (2006).
7. H. Cao, G. Huang, S. Xuan, Q. Wu, F. Gu, C. Li, “Synthesis and characterization of carbon-coated iron core/shell nanostructures,” *J. Alloy Compd.* **448**, 272–276 (2008).
8. P. Wust, B. Hildebrandt, G. Sreenivasa, B. Rau, J. Gellermann, H. Riess *et al.*, “Hyperthermia in combined treatment of cancer,” *Lancet Oncol.* **3**, 488–497 (2002).
9. D. L. Liu, S. Andersson-Engels, C. Stureson, K. Svanberg, C. H. Håkansson, S. Svanberg, “Tumour vessel damage resulting from laser-induced hyperthermia alone and in combination with photodynamic therapy,” *Cancer Lett.* **111**, 157–165 (1997).
10. J. Eichler, J. Liebetrueth, R. A. London, L. Ziegenhagen, “Temperature distribution for combined laser hyperthermia-photodynamic therapy in the esophagus,” *Med. Eng. Phys.* **22**, 307–312 (2000).
11. Y. L. Klaver, T. Hendriks, R. M. Lomme, H. J. Rutten, R. P. Bleichrodt, I. H. de Hingh, “Hyperthermia and intraperitoneal chemotherapy for the treatment of peritoneal carcinomatosis: An experimental study,” *Ann Surg.* **254**(1), 125–130 (2011).
12. W. Rao, Z. S. Deng, J. Liu, “A review of hyperthermia combined with radiotherapy/chemotherapy on malignant tumors,” *Crit. Rev. Biomed. Eng.* **38**(1), 101–106 (2010).
13. T. M. Zagar, K. A. Higgins, E. F. Miles, Z. Vujaskovic, M. W. Dewhirst, R. W. Clough *et al.*, “Durable palliation of breast cancer chest wall recurrence with radiation therapy, hyperthermia, and chemotherapy,” *Radiother. Oncol.* **97**(3), 535–540 (2010).

14. T. Kobayashi, "Cancer hyperthermia using magnetic nanoparticles," *Biotechnol J.* **6**(11), 1342–1347 (2011).
15. Y. S. Chang, S. Savitha, S. Sadhasivam, C. K. Hsu, F. H. Lin, "Fabrication, characterization, and application of greigite nanoparticles for cancer hyperthermia," *J. Colloid Interface Sci.* **363**(1), 314–319 (2011).
16. L. A. Dombrovsky, V. Timchenko, M. Jackson, G. H. Yeoh, "A combined transient thermal model for laser hyperthermia of tumors with embedded gold nanoshells," *Int. J. Heat Mass Transfer* **54**, 5459–5469 (2011).
17. S. Soni, H. Tyagi, R. A. Taylor, A. Kumar, "Role of optical coefficients and healthy tissue-sparing characteristics in gold nanorod-assisted thermal therapy," *Int. J. Hyperthermia* **29**(1), 87–97 (2013).
18. C. Iancu, L. Mocan, "Advances in cancer therapy through the use of carbon nanotube-mediated targeted hyperthermia," *Int. J. Nanomedicine* **6**, 1675–1684 (2011).
19. D. K. Chatterjee, P. Diagaradjane, S. Krishnan, "Nanoparticle-mediated hyperthermia in cancer therapy," *Ther. Deliv.* **2**(8), 1001–1014 (2011).
20. M. Chu, Y. Shao, J. Peng, X. Dai, H. Li, Q. Wu *et al.*, "Near-infrared laser light mediated cancer therapy by photothermal effect of Fe<sub>3</sub>O<sub>4</sub> magnetic nanoparticles," *Biomaterials* **34**(16), 4078–4088 (2013).
21. H. F. Rodrigues, F. M. Mello, L. C. Branquinho, N. Zufelato, E. P. Silveira-Lacerda, A. F. Bakuzis, "Real-time infrared thermography detection of magnetic nanoparticle hyperthermia in a murine model under a non-uniform field configuration," *Int. J. Hyperthermia* **29**(8), 752–767 (2013).
22. E. Al-Fakih, N. A. Abu Osman, F. R. M. Adikan, "The use of fiber Bragg grating sensors in biomechanics and rehabilitation applications: The state-of-the-art and ongoing research topics," *Sensors (Basel)* **12**(10), 12890–12926 (2012).
23. A. A. Abushagur, N. Arsad, M. I. Reaz, A. A. Bakar, "Advances in bio-tactile sensors for minimally invasive surgery using the fibre Bragg grating force sensor technique: A survey," *Sensors (Basel)* **14**(4), 6633–6665 (2014).
24. D. Tosi, E. G. Macchi, M. Gallati, G. Braschi, A. Cigada, S. Rossi, G. Leen, E. Lewis, "Fiber-optic chirped FBG for distributed thermal monitoring of *ex-vivo* radiofrequency ablation of liver," *Biomed. Opt. Express* **5**(6), 1799–1811 (2014).
25. F. Taffoni, D. Formica, P. Saccomandi, G. Di Pino, E. Schena, "Optical fiber-based MR-compatible sensors for medical applications: An overview," *Sensors (Basel)* **13**(10), 14105–14120 (2013).
26. Ö. Burak, J. Wei, Y. Osamu, F. Kiyoshi, N. Zenbe-E, "Preparation and characterization of carbon-coated ZnO and CaO powders by pyrolysis of PVA," *J. Mater. Sci.* **42**(3), 983–988 (2007).
27. J. P. Williams, P. Southern, A. Lissina, H. C. Christian, A. K. Sewell, R. Phillips *et al.*, "Application of magnetic field hyperthermia and superparamagnetic iron oxide nanoparticles to HIV-1-specific T-cell cytotoxicity," *Int. J. Nanomedicine* **8**, 2543–2554 (2013).
28. I. Hilger, "*In vivo* applications of magnetic nanoparticle hyperthermia," *Int. J. Hyperthermia* **29**(8), 828–834 (2013).