

Enabling Remote Design and Troubleshooting Experiments Using the iLab Shared Architecture

J. L. Hardison, K. DeLong, V. J. Harward, J. A. del Alamo, R. Shroff, O. Oyabode

Center for Educational Computing Initiatives, Massachusetts Institute of Technology,
77 Massachusetts Ave., 9-321, Cambridge, MA 02139; email: hardison@mit.edu

ABSTRACT

The MIT iLab Project is dedicated to the goal of increasing laboratory experimentation opportunities for engineering students worldwide. Since its inception in 1998, the project has furthered this goal through the development of individual remote laboratories, or iLabs, as well as a distributed software infrastructure designed to streamline the implementation and sharing of remote laboratories. iLabs are designed to complement traditional, hands-on laboratories by providing practical educational experiences where they would not otherwise be available. Such remote labs, developed and hosted by MIT and other institutions within the iLab Consortium, have been successfully used by instructors at schools across the educational spectrum and around the world. While certainly valuable, many of the original experiments available through the iLab platform provide a limited experience in that they are observational in nature. They only provide students the ability to study the behavior of a pre-defined system under test. Such labs have proven to be valuable additions to engineering curricula, but do not have the flexibility that is inherent in a traditional laboratory experience. To address this, the MIT iLab Project has begun focusing on the development of iLabs that provide students with the ability to design or troubleshoot experimental systems. Through two particular remote labs, focusing on electronic control system analysis and basic electronics test and measurement respectively, the project is designing remote labs that provide a more flexible learning experience for students and are more attractive to instructors in a broad set of disciplines.

INTRODUCTION

Laboratory experiences are a valuable component of a practical education in a variety of fields. As a complement to theoretical instruction, a hands-on laboratory experience can solidify a student's understanding of a topic and allow them to explore behaviors that are not easily modeled. However, there are a number of cases where a traditional, hands-on laboratory component may not be available to students. These cases all tend to revolve around issues of lab cost and availability. Traditional labs require instrumentation that is housed in a safe and easily accessible physical space. Trained staff are also needed to maintain equipment and assist students. Further, large numbers of students must be served either by large laboratories or by scheduling

that may limit a student's lab time. This can render a valuable laboratory experience impractical. In such cases, remote laboratories can be an attractive alternative.

The MIT iLab Project is dedicated to increasing the number and variety of laboratory experiences available to students by developing Internet-based remote laboratories, or iLabs. Generally speaking, remote laboratories allow students and instructors to access real lab hardware from anywhere and at any time over the Internet. A lab manager can make a single set of instrumentation available for use by many students by building it as a remote lab. Remote labs can also provide students with access to instrumentation that is physically distant, rare, dangerous or otherwise difficult to interact with as a traditional lab.

iLabs are remote laboratories that can be easily constructed and shared using the iLab Shared Architecture. The iLab Shared Architecture (ISA) provides a distributed web-based framework for the development of remote laboratories (Harward, 2004). Lab developers can take advantage of a variety of existing generic services, such as user authentication and data storage, and easily share their labs with others around the world. Since the inception of the project in 1998, iLabs hosted at MIT have been used by students at 22 universities across five continents. There are also a growing number of universities who are adopting the ISA and developing their own iLabs (Harward, 2008; Jiwaji, 2009; Kehinde, 2007). Interest in the concept and architecture is such that these iLab partner institutions have come together to form a consortium to support the development of a broad range of remote laboratories that can be used in a variety of educational settings.

Concentrated efforts by this diverse group of stakeholders have yielded a number of successful iLabs (Akinwale, 2009; Ayodele, 2009; Harward, 2008; Jiwaji, 2009). This includes MIT's Microelectronics Device Characterization iLab, which has been regularly used in courses at MIT for over a decade (Harward, 2008).

Aside from its success, the Microelectronics iLab is similar to other existing iLabs in that it is observational in nature. Students primarily use the system to observe the behavior of a predefined device-under-test. While this is quite valuable, especially in cases where a laboratory component would not otherwise be available, it can be a somewhat limited experience. Students are not able to perform design-oriented tasks or troubleshoot faulty systems as they would in a traditional lab. This can constrain how instructors use iLabs in their courses and increase the perceived value gap between traditional and online laboratories. In response to this, a number of iLabs that integrate design or troubleshooting capabilities are being developed.

This paper will detail work undertaken by the MIT iLab Project to provide iLabs that support design and troubleshooting based experiments. As a basis for this discussion, it will describe the MIT Microelectronics iLab as an exemplar of an observational remote laboratory. Following that, a pair of recently updated iLabs, the MIT Dynamic Signal Analyzer and NI-ELVIS iLabs, which incorporate design and troubleshooting capabilities, will be detailed. This paper will show that iLabs of this

kind that are robust, highly versatile and provide levels of flexibility approaching those of traditional laboratories can be developed and leveraged by instructors in a variety of disciplines.

EXPERIENCES WITH OBSERVATIONAL iLABS

At the beginning of the MIT iLab Project, remote lab development efforts revolved around providing access to a particular set of experimental apparatus. At that time, remote labs were being developed in a variety of fields. In particular, a flagpole instrumented with accelerometers was developed for students in civil engineering courses, a heat exchanger remote lab was developed within chemical engineering and a microelectronics device characterization lab was developed for electrical engineering students (Amaratunga, 2002; Colton, 2004; del Alamo, 2002). Each of these first-version remote labs provided the ability to observe the behavior of fixed resources. The instrumented flagpole measured the movement of a structure in response to environmental factors. The heat exchanger allowed control and observation of a defined thermal transfer system. The microelectronics lab allowed students to perform current-voltage measurements on off-the-shelf electronic devices. In each of these cases, as the focus of remote lab development was on providing reliable and educationally valuable access to lab instrumentation over the Internet, the systems that were under test or observation were kept relatively simple.

This is not to say that these remote labs were simplistic. Focusing on the microelectronics device characterization lab, which would eventually become the MIT Microelectronics Device Characterization iLab in use today, this system provided students with control of industry-grade electronics test equipment. The instrumentation at the core of this lab, a semiconductor parameter analyzer, was within the financial reach of a well-funded research project, but not that of a small instructional lab. This instrument can perform complex measurements with a high degree of speed, flexibility and precision. It also allows users to perform real-time mathematical analysis of measured data. By placing such a piece of equipment online, large numbers of students can perform such measurements as part of their course assignments without requiring physical access to the lab. Indeed, with such a remote lab made reliably available over the Internet, a single instrument was able to support hundreds of students completing course assignments at universities worldwide (del Alamo, 2003).

Over the intervening years, the Microelectronics Device Characterization iLab has undergone significant development to increase its reliability, scalability and educational value (del Alamo, 2002; Hardison, 2005). Soon after its initial release a switching matrix was added to enable multiple devices to be connected to the system at a given time. This allowed users to select one device to test from a set, enabling multiple courses using different devices to be supported at a given time. Advanced lab administration controls were added to simplify the work of those managing the remote lab and to allow fine-grain control of device usage in order to reduce hardware failure rates. Additionally, significant software development occurred with the goal

of creating a robust, modular remote laboratory system that can gracefully and reliably scale up to large numbers of simultaneous users. All of this has led to a remote lab system that has become a regular feature in electrical engineering education at MIT as well as other universities and is one of the flagship offerings of the MIT iLab Project.

While the technology supporting the Microelectronics iLab has grown significantly over time, the educational experience has remained relatively constant. Students today are using this lab to observe pre-defined devices or small circuits in the same way they did with the first version of this lab in 1998. A variety of assignments have been crafted to leverage this capability in different ways. However, the experience provided by the Microelectronics iLab, as well as many other available iLabs, remains primarily observational. Students analyze the behavior of a fixed system. Whether that is a factory-assembled transistor or a flagpole in a university courtyard, it is a system that the student has a limited ability to interact with.

It is this level of interactivity with the subject of a lab experiment that has continued to separate remote laboratory experiences from their traditional counterparts. A traditional lab is a highly flexible environment. System behavior can be manipulated by changing parameters or by modifying or replacing whole components. Observations of the system are limited only by the student's ability to place an appropriate sensor. The student has a high degree of control over both the system-under-test and how it is observed.

The value of remote laboratories, either as a complement to traditional labs or as a substitute, has been demonstrated (Fischer, 2007; Harward, 2008). Particularly in an educational environment where distance learners are receiving course materials and submitting assignments online, remote laboratory facilities have an obvious benefit. However, in order to create versatile remote laboratories that let students explore the behavior and operation of a system-under-test they must provide capabilities that more closely resemble their traditional counterparts.

DEVELOPING MORE VERSATILE iLABS

In order to provide more flexible remote laboratory experiences to students, the MIT iLab Project has begun investigating a pair of approaches. The first of these is to incorporate elements of design into the laboratory experience by providing control of the behavior of the system-under-test. This approach has been implemented in our Dynamic Signal Analyzer iLab.

The second approach is to provide students with the ability to perform troubleshooting-style tasks from a remote lab interface. This is, at its core, still an observational experience, but it is one that requires a high degree of flexibility and is a valuable part of a traditional, hands-on lab. This functionality has been included in a recent prototype version of our NI-ELVIS electronics iLab. While each approach has been primarily implemented in distinct iLabs – largely a result of specific

functionality requirements by those who use them – both the Dynamic Signal Analyzer and NI-ELVIS iLabs contain aspects of both design and troubleshooting approaches.

Supporting Design-based Experiments with the MIT Dynamic Signal Analyzer iLab

The MIT Dynamic Signal Analyzer (DSA) iLab is similar to its microelectronics counterpart in that it provides students with remote access to industry-grade electronics test instrumentation. In the case of the DSA iLab, students are able to perform frequency-domain characterization measurements on electronic filters and feedback control systems using an Agilent 35670A dynamic signal analyzer. The DSA iLab was originally implemented in 2004 and first deployed in a senior-level feedback and control system course at MIT (Viedma, 2005). In this initial version, students could perform swept-sine measurements to observe the behavior of electronic systems in the frequency domain. The client interface currently used for this experiment is shown in Figure 1.

There was also functionality built into this lab to support the testing of circuits whose behavior could be changed by parameters supplied by students using the remote lab interface. This was achieved by the use of a simple LabJack I/O device connected to a system-under-test built using voltage-controllable components. This hardware configuration is shown in Figure 2. By defining a set of control signals, students could elicit a wide range of responses from the system-under-test. This was a powerful tool for instructors and students. Rather than merely observing the behavior

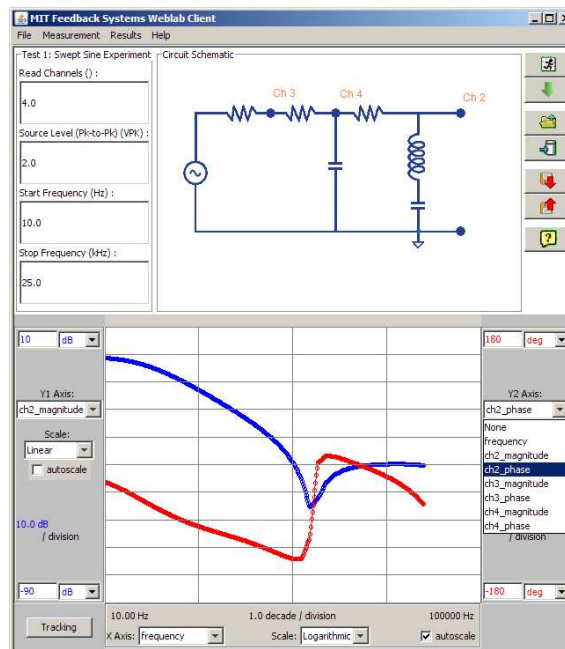

Figure 1. Lab Client interface to the MIT Dynamic Signal Analyzer iLab

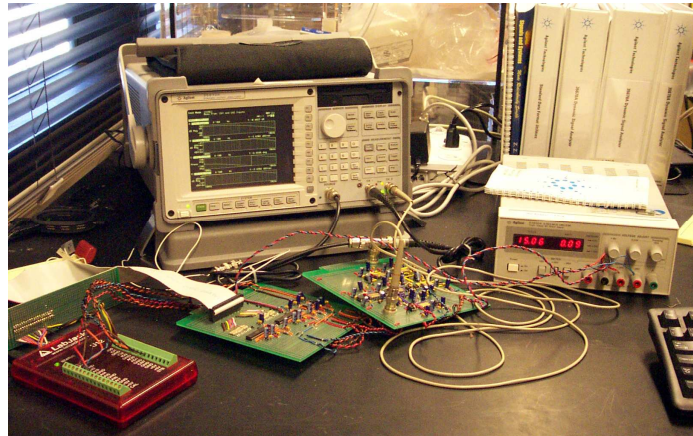

Figure 2. Instrumentation for the MIT Dynamic Signal Analyzer iLab. Agilent 35670A, LabJack I/O unit, circuit-under-test and power supply.

of pre-defined circuits and leaving design exercises as purely theoretical tasks, this iLab allowed students to remotely implement, test and refine a design on state-of-the-art instrumentation. Unfortunately, only one rather complex multi-stage control circuit was developed to take advantage of this capability. Further, the DSA iLab found more regular use in introductory circuits courses. As a result, simpler static circuits were used more regularly and the design-oriented capabilities of this iLab went under-utilized.

Over the past two years the MIT iLab Project has engaged in efforts to remedy this situation. A project is underway to increase both the functionality and scalability of the DSA iLab as well as its use of dynamically configurable circuits. The essential motivation of this effort is that a well-featured, design-oriented remote laboratory focused on electronic control systems would be of value in a variety of engineering disciplines. To this end, efforts are underway to expose time domain step-response measurement capabilities in the DSA instrumentation. Further, a switching matrix has been integrated into this laboratory setup. This switching matrix will route the data and control signals from the dynamic signal analyzer and LabJack instruments to one of a set of available test circuits based on input from the remote lab user. This topology is further detailed in Figure 3. The result of this work is a single remote laboratory that could perform a near-complete analysis of a set of electronic filters or control circuits. The use of switching will allow this iLab to easily support multiple assignments at a given time, increasing the ability of this remote laboratory experience to benefit a large number of students.

At the same time, the project is focused on re-introducing the design-oriented capabilities of this iLab. The primary reason that these capabilities went under-utilized was that the circuit designed to leverage them was not well-matched to its audience. A complex control system made sense for a senior-level controls course but is well outside the scope of the introductory courses that currently use the DSA iLab. As such, the project's efforts to remedy this situation involve both technical

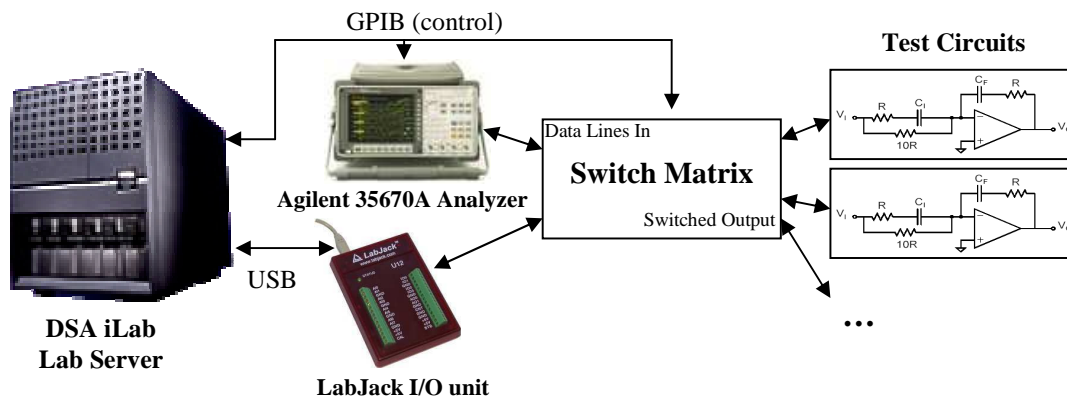

Figure 3. Instrument topology for the updated Dynamic Signal Analyzer iLab. The signal analyzer and switch matrix are controlled over GPIB and the LabJack I/O unit over USB. Instrument signal lines are routed to one of a set of test circuits based on user input parameters.

and curricular development efforts. On the technical side, the MIT iLab Project is developing a series of simpler, canonical filter and control system circuits designed to leverage the design-oriented capabilities of the DSA iLab. These will include basic electronic filters and single stage feedback control systems that are more typically taught in introductory circuits and signal processing courses.

In terms of curricular development, tutorials detailing the capabilities of these test circuits and describing potential lab exercises are being developed as a means of reducing the initial burden an instructor would face by integrating the DSA iLab into their courses. Ultimately, the MIT iLab Project relies on instructors to develop and share assignments that utilize iLabs. However, tutorials highlighting possible methods of integrating the DSA iLab into courses will seed this process and increase the range of instructors likely to use and develop curricular materials beyond those most committed to the concept of remote laboratories.

These efforts will result in a new Dynamic Signal Analyzer iLab that provides a complete, design-oriented control system characterization platform. The inclusion of switching into this iLab will also increase its ability to support multiple experiments using a variety of static and dynamically controllable test circuits. Further, the development of basic tutorials to seed curricular development will help instructors integrate this iLab into their courses. Taken together, the new Dynamic Signal Analyzer iLab will be of significant value to many students and instructors in electrical engineering as well as other disciplines where signal processing and control systems are taught.

Providing Troubleshooting Capabilities with the NI-ELVIS iLab

In 2005, the MIT iLab Project began developing remote electronics laboratories based on the National Instruments Electronics Laboratory Virtual Instrumentation Suite (NI-ELVIS) (Jiwaji, 2009). The NI-ELVIS is a compact, relatively low cost

hardware platform that, when used with a standard desktop computer, provides the measurement capabilities of a basic electronics lab. This includes function generators, an oscilloscope, bode analysis capabilities and digital I/O as well as a well-featured digital multimeter. Initial iLabs based on the NI-ELVIS platform exposed only a fraction of the instrument's capabilities. Subsequent versions have seen the incorporation of more of the NI-ELVIS's instruments into the iLab framework. While iLabs based on the NI-ELVIS platform were originally intended as low-cost alternatives to iLabs using more expensive industry-grade instrumentation, the NI-ELVIS iLab has proven itself to be equally valuable as a result of its versatility. The most recently deployed NI-ELVIS based iLab allows students to perform basic time and frequency domain measurements on a wide variety of electronic circuits from a single remote interface.

Despite the advancement of the NI-ELVIS based iLabs as they incorporate more of the instrumentation's capabilities, these remote labs have remained primarily observational experiences. In recent years, however, the MIT iLab Project has investigated ways to provide more design and troubleshooting oriented experiences with the NI-ELVIS. These efforts have revolved around the use of switching hardware to increase the variability of the circuits-under-test as well as the flexibility of making certain measurements. Initial work along this vein, prompted by iLabs developed at Obafemi Awolowo University, involved using switching to allow students to dynamically configure circuits (Ayodele, 2008; Harrison, 2008). Where the DSA iLab uses voltage-controlled components to achieve this effect, user-controllable switching has been used with the NI-ELVIS to allow students to select which components will be wired into the circuit. More recently, a prototype version of the NI-ELVIS iLab that uses switching with the instrument's digital multimeter to enable troubleshooting-style experiments has been produced (Shroff, 2009).

A traditional, hands-on laboratory is an ideal venue for developing troubleshooting skills. Errors in a laboratory setup, either as a result of an accidental mis-configuration or a purposefully introduced problem, are part of the very distinction between a "real-world" experience and its idealized, theoretical counterpart. Further, the flexibility inherent in a traditional lab enables students to explore a wide variety of troubleshooting methods and solutions. In a traditional, hands-on lab, the student is able to make measurements wherever he or she is able to place an instrument probe. It is this flexibility of measurement that the MIT iLab Project sought to develop in a NI-ELVIS based troubleshooting-capable iLab.

In the prototype version of the NI-ELVIS based troubleshooting iLab, switching was used with the instrument's digital multimeter to create a versatile remote circuit test laboratory. On its own, the multimeter built into the NI-ELVIS is capable of a wide variety of measurements. It can measure current and voltage at a circuit node as well as the resistance, capacitance or inductance of a component. This alone provides a powerful tool for circuit troubleshooting. However, the NI-ELVIS is limited in that it only has one set of physical terminals to the digital multimeter instrument. As such,

some switching capability was needed to allow remote users to “move” the multimeter probe connections around the circuit in an easily controllable way.

For the prototype NI-ELVIS troubleshooting iLab, the digital multimeter probe terminal is connected through a collection of switches to different points of interest within a given circuit-under-test. This physical configuration, detailing the circuit and the switches connected to each circuit node, is specified by the lab administrator in the iLab’s experiment configuration. This configuration is then relayed to the student’s lab client interface, which displays the circuit along with potential probe points as shown in Figure 4. Students can then configure their measurements by selecting the appropriate multimeter function (current, voltage, capacitance, etc.) and probe points. As such, students are able to “place” the probes of the digital multimeter within the circuit and perform a variety of measurements. Circuit behavior can be analyzed by measuring voltages across circuit branches or current values at circuit nodes. Further, components can be measured for their resistance, capacitance or inductance values. With a level of flexibility beginning to approach that of a traditional lab, a wide variety of circuit analysis and troubleshooting experiments assignments can be crafted with the functionality of this iLab.

DEPLOYING DESIGN- AND TROUBLESHOOTING-FOCUSED iLABS

While the versions of both the Dynamic Signal Analyzer and NI-ELVIS iLabs described here are still in prototype stages of deployment, both have potential to bring a versatile remote laboratory experience to a wide range of users. Currently deployed, observationally oriented versions of each of these iLabs are regularly used by instructors in courses at MIT and at other institutions. With the increase in

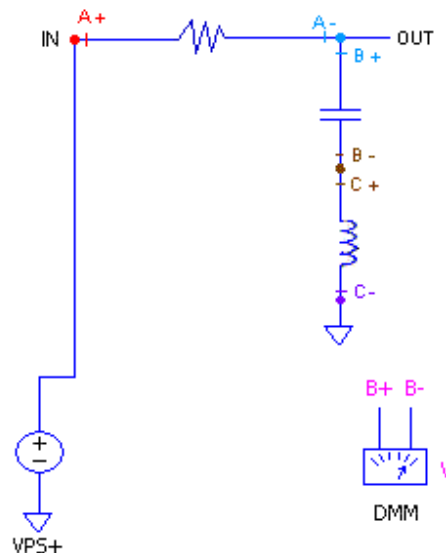

Figure 4. RLC Circuit with lab client rendered instrument terminals (variable power supply and digital multimeter). Electrical nodes available for probing are represented by labeled clusters.

flexibility and capability of each of these iLabs, the MIT iLab Project expects that both will appeal to even broader audiences.

Deployment of this latest revision of the DSA iLab will provide a wide range of students with a remote laboratory environment where they can implement and test designs rather than merely observe static circuits. This also broadens the range of experiments that can be entertained with a given circuit-under-test in much the same way that the switching matrix did for the Microelectronics Device Characterization iLab. Certain students may observe the circuit only in a single, predefined, effectively static configuration while others may perform more design-oriented assignments. This, coupled with the potential reach of the DSA iLab from electrical engineering into other fields which teach feedback and control systems, provides the potential for a large number of students at a variety of levels and across a breadth of disciplines to benefit from this iLab.

Meanwhile, the NI-ELVIS based iLab will bring a highly flexible remote electronics test laboratory experience to students across the educational spectrum. As with the DSA iLab, a troubleshooting-enabled NI-ELVIS iLab will have even more value for students in design-oriented courses that presently use NI-ELVIS based iLabs. This iLab will also be of value to students in programs where troubleshooting skills are more highly emphasized. In particular, the MIT iLab Project has been working with the Maricopa Advanced Technology Education Center (MATEC) to help develop a remote lab to support a new electronics technician curriculum (Jiwaji, 2009). Instructors in this curriculum are less concerned with teaching device-level behavior than they are with teaching system-level analysis and troubleshooting techniques. As such, a remote lab based on a low-cost platform, such as the NI-ELVIS, that provides troubleshooting capabilities would address the needs of a wide range of students and instructors. This audience will likely continue to grow as an increasing number of both technician- and engineer-oriented programs are put online for distance learners.

CONCLUSIONS & FUTURE WORK

Through the development of the latest Dynamic Signal Analyzer and NI-ELVIS iLab prototypes, remote laboratories that are fundamentally more versatile than their more observational counterparts are being made available. Rather than discounting the approaches of earlier observational experiences, these new iLabs build upon their successes and the lessons learned from them. The MIT Microelectronics Device Characterization iLab in particular has evolved into a robust and versatile remote laboratory that, every year, provides a steady number of students from around the world with the ability to observe the behavior of a wide range of electronic devices and circuits. Building upon this work by constructing iLabs that are equally robust but feature design and troubleshooting capabilities serves to broaden the potential audience for iLabs and close the gap between remote and traditional laboratories.

Both the DSA and NI-ELVIS prototype iLabs are based on remote laboratories that target students in electrical engineering programs yet have the potential to appeal to

broader groups. The DSA iLab, with its focus on feedback and control systems, provides a remote laboratory experience in a topic that is taught in a number of engineering disciplines. The addition of a robust design-oriented component to this iLab will increase its appeal, particularly to instructors and programs that focus more on system design than analysis. Likewise, the troubleshooting capability of the NI-ELVIS iLab will appeal to users interested in analyzing and testing electronic systems with a high degree of flexibility rather than merely observing the behavior of a static system. Further, the DSA and NI-ELVIS iLabs both provide their new capabilities in the most flexible way possible. While such iLabs will not be replacements for hands-on experiences, they will provide as close to a traditional experience as possible in cases where remote laboratories are the most reasonable solution.

Moving forward, the MIT iLab Project is in the process of bringing both the Dynamic Signal Analyzer and NI-ELVIS troubleshooting iLabs from prototype to full deployment-ready systems. In the case of the DSA iLab, this involves further development and testing of this system with initial deployment anticipated at the end of the 2009-2010 academic year. With respect to the NI-ELVIS iLab, the described troubleshooting capabilities will be refined and integrated into the core deployed NI-ELVIS iLab implementation. This core implementation captures all of the feature development for the NI-ELVIS iLab into a single, versatile platform for use in a variety of educational situations. Further, as these iLabs find audiences in a broader range of educational environments, the iLab Project will have to think critically about how these iLabs serve each of these groups. While a single, one-size-fits-all approach may be the most convenient for lab developers, it may also be the least effective for lab users. This will likely involve improving elements of how these iLabs are presented (e.g. user interface design, documentation, etc.) and will require input from stakeholders across the educational spectrum.

ACKNOWLEDGEMENTS

This work has been supported in part by the Carnegie Corporation of New York, the Maricopa Advanced Technology Education Center, the Microsoft Corporation through iCampus (the MIT-Microsoft Alliance), the National Science Foundation under award #0702735, by the Singapore-MIT Alliance, the Singapore-MIT Alliance for Research and Technology and by MIT Alumni Funds (Classes of '51, '55, '60, and '72) as well as through equipment donations from National Instruments, Agilent Technologies, AMD, Hewlett-Packard and Intel.

REFERENCES

Akinwale, O., Kehinde, L., Ayodele, K., Jubril, A., Jonah, O., *et al.* (2009). "A LabVIEW-based On-line Robotic Arm for Students' Laboratory." ASEE, Austin, TX, June 14, 2009.

Amaratunga, K. and Sudarshan, R. (2002). "A Virtual Laboratory for Real-Time Monitoring of Civil Engineering Infrastructure." International Conference on Engineering Education 2002, Manchester (UK), Aug. 18–22, 2002.

Ayodele, K. P., Kehinde, L.O., Jonah, O., Ilori, O., Ajayi, E.O.B., et al. (2008). "Development Of An Operational Amplifier Virtual Laboratory Based On ILab Architecture And NI Elvis." Proceedings of the ASEE Annual Conference and Exposition, Pittsburgh, PA, June 2008. Nominated for Best Paper award at the Conference.

Ayodele, K., Akinwale, O., Kehinde, L., Osasona, O., Ajayi, E., et al. (2009). "Advanced Digital Laboratory: An FPGA-Based Remote Laboratory for Teaching Digital Electronics." ASEE, Austin, TX, June 14, 2009.

Colton, C. K., Knight, M. Q., Khan, R.-A., and West, R. (2004). "A Web-Accessible Heat Exchanger Experiment." INNOVATIONS 2004: World Innovations in Engineering Education Research, Ed. W. Aung, R. Altenkirch, T. Cermak, R. W. King, and L. M. S. Ruiz, Eds. Arlington, VA: iNEER, 2004, pp. 93–106.

del Alamo, J. A., Brooks, L., McLean, C., Hardison, J., Mishuris, G., et al. (2002). "The MIT Microelectronics WebLab: a Web-Enabled Remote Laboratory for Microelectronics Device Characterization." 2002 World Congress on Networked Learning in a Global Environment, Berlin (Germany), May 2002.

del Alamo, J. A., Chang, V., Brooks, L., McLean, C., Hardison, J., *et al.* (2003). "MIT Microelectronics WebLab." Book chapter in "Lab on the Web - Running Real Electronics Experiments via the Internet", T. Fjeldly and M. Shur, Eds., Wiley, 2003, pp. 49-87.

Fischer, J. H., Mitchell, R., and del Alamo, J. A. (2007). "Inquiry-Learning with WebLab: Undergraduate Attitudes and Experiences." Journal of Science Education and Technology, Springer Netherlands. Volume 16, Number 4, August, 2007.

Hardison, J. L., Zych, D., del Alamo, J. A., Harward, V. J., Lerman, S. R., *et al.* (2005). "The Microelectronics WebLab 6.0 – An Implementation Using Web Services and the iLab Shared Architecture." International Conference on Engineering Education and Research 2005, Tainan, Taiwan, March 1-5, 2005.

Harrison, B. (2008). Masters Thesis, Expanding the Capabilities of the ELVIS iLab Using Component Switching, Department of Electrical Engineering and Computer Science, Massachusetts Institute of Technology (May 2008).

Harward, J., del Alamo, J. A., Choudary, V. S., DeLong, K., Hardison, J. L., *et al.* (2004). "iLabs: A Scalable Architecture for Sharing Online Laboratories." presented at the International Conference on Engineering Education 2004, Gainesville, Florida, October 16-21, 2004.

Harward, V. J., del Alamo, J. A., Lerman, S. R., Bailey, P., Carpenter, J, *et al.* (2008). "The iLab Shared Architecture: A Web Services Infrastructure to Build Communities of Internet Accessible Laboratories." *Proceedings of the IEEE* Vol. 96, No. 6, June 2008.

Jiwaji, A., Hardison, J., Ayodele, K., Tickodri-Togboa, S., Mwambela, A., *et al.* (2009). "Collaborative Development of Remote Electronics Laboratories: The ELVIS iLab." ASEE, Austin, TX, June 14, 2009.

Kehinde, .L. O. (2007). "iLabs and Curriculum Enhancement" Engineering Africa." Conference Abuja, Nigeria. March 4-6, 2007.

Shroff, R., Soumare, H., Hardison, J., del Alamo, J., Harward, J., *et al.* (2009). "A Versatile Internet-Accessible Electronics Workbench with Troubleshooting Capabilities." REV 2009, Bridgeport, CT, June 2009.

Viedma, G., Dancy, I. J. and Lundberg, K. H. (2005). "A Web-based Linear-Systems iLab." American Control Conference, Portland, OR, Jun.8–10, 2005.