

# An evaluation of options to mitigate voltage rise due to increasing PV penetration in distribution networks

Craig E. Carter<sup>\*</sup>, Martina Calais, Pengcheng Lu, and Julian A. Crocker

School of Engineering and Information Technology, Murdoch University, Perth, Australia

Received: 3 January 2017 / Received in final form: 21 July 2017 / Accepted: 27 July 2017

**Abstract.** Australia and most other countries are adopting renewable energy generation as the dominant means of reducing dependence on fossil fuels. This has been made more feasible by the exponential take-up of solar-photovoltaic (PV) systems and their concurrent production scale-up and cost decline. Rooftop solar PV, combined with battery storage, seems likely to be the dominant means of providing household electricity needs. In response to the technical challenges from rooftop PV, network utilities have implemented various low cost options to cope with PV's impact on network voltages. However, if we want this clean energy technology to fully utilise the available roof space and eventually meet residential electricity needs, additional hardware, control and commercial options will need to be adopted by both network utilities and their customers to overcome the technical barriers, especially voltage rise. This paper presents the authors' evaluations of options to mitigate voltage rise, including operating solar inverters with reactive power absorption (var absorbing), dependent only on solar power output or operating the solar inverters in a volt-var response mode (voltage droop control) where the inverter adjusts its reactive power ( $Q$ ) in response to changes in its terminal voltage –  $Q(V)$ . This paper also considers the fulltime  $Q(V)$  option, where an inverter's reactive power capacity is independent of solar conditions – statcom mode. The network utility option of using line drop compensation (LDC – used on long rural MV feeders) on urban MV feeders during daylight hours is assessed to lessen voltage rise on LV feeders with low net loading or reverse power flow due to high solar PV generation. The paper concludes that a combination of solar inverters performing fast fulltime voltage droop control outside a voltage deadband (statcom mode) and HV/MV substation transformers with slow acting daytime LDC mitigates voltage rise, whilst limiting feeder reactive power requirements.

## 1 Introduction

It appears increasingly probable, given the declining costs, that most dwellings that can accommodate rooftop photovoltaics (PV) will be fitted with solar panels. Rooftop PV may become the norm, provided technical barriers do not prevent this. Network utilities in Australia have not yet had to modify or augment distribution networks to accommodate the current level of solar PV penetration. However, to become the social norm, customers with rooftop PV, who both consume and produce electricity – sometimes called prosumers, and utilities may both need to play a role in mitigating the adverse technical effects of rooftop PV saturation. The most prominent of these is voltage rise and this paper considers and assesses options that prosumers and utilities could adopt to prevent voltage rise being the limiting barrier.

A basic prosumer option, required by some utilities, is for the solar inverter to have a  $P(V)$  characteristic, also called a volt-watt response mode, whereby a solar

inverter's power output is progressively reduced, as the voltage rises above a selected upper acceptable level. Western Power, the network operator/owner of the South West Interconnected Network in Western Australia, currently requires a volt-watt response mode to be enabled with the default settings given in the Australian/New Zealand Standard AS/NZS 4777.2:2015 [1,2]. As the aim is to facilitate high urban PV penetration, only options that mitigate voltage rise, without resorting to curtailing solar power, are evaluated.

The simplest prosumer option to mitigate voltage rise, without resorting to power curtailment, is to operate solar inverters with absorbing vars, rather than at unity power factor. Under this option, the solar inverters can be programmed to operate at unity PF up to a threshold solar power ( $P$ ) level, e.g. 50% of rated power [1]. Above this power threshold, reactive power ( $Q$ ) absorption commences and reaches a defined power factor limit when operating at rated power, e.g. 0.95 PF absorbing. Absorbing  $Q$  reduces network voltages partially offsetting the voltage rise caused by  $P$  [3]. It is a very effective option in networks with relatively high  $X/R$  ratios (e.g. HV networks), but less

<sup>\*</sup> e-mail: [craig.carter@murdoch.edu.au](mailto:craig.carter@murdoch.edu.au)

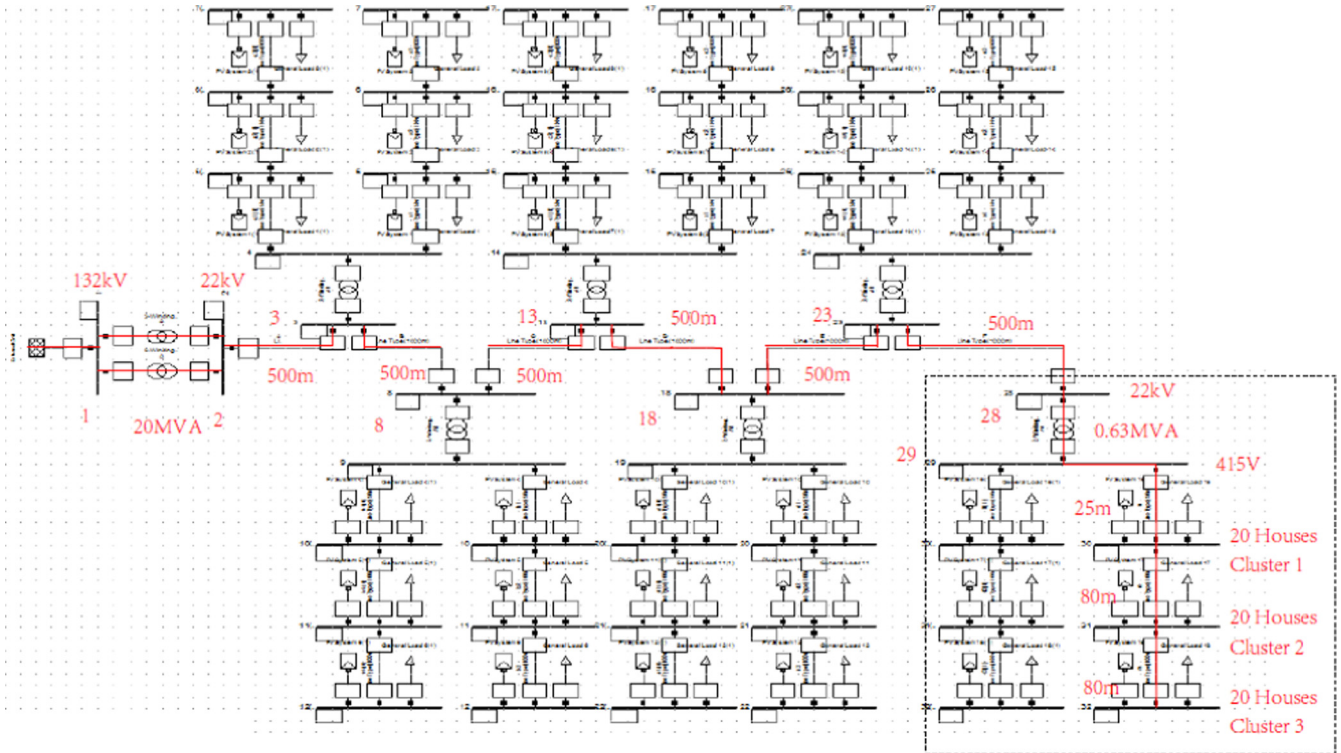

**Fig. 1.** PowerFactory model of the example 22 kV urban feeder with LV distribution [10].

effective in LV networks with low  $X/R$  ratios where variations in  $Q$  can have a lesser influence on voltage than variations in  $P$  [4,5]. The increasing adoption of underground MV and especially LV bundled cables is reducing  $X$  even more than  $R$ , due to the very low inductance of bundled cables compared to spatially separated overhead conductors. There is still a role for solar inverters with active  $Q$  control, if programmed to absorb significant amounts of  $Q$  only when network voltages are excessive.

Hence the option of programming solar inverters with a  $Q(V)$  characteristic, also called a volt-var response mode is evaluated, where the  $\pm Q$  range has defined limits [1,6]. These defined limits may be expressed as a percentage of rated power or as a  $\pm PF$  range, e.g.  $\pm 0.9 PF$ . The final prosumer option to be evaluated is solar inverters with a  $Q(V)$  characteristic, where the  $\pm Q$  limits are independent of  $P$  (statcom functionality), as some solar inverters now have this mode [7]. In this analysis, it is assumed that the inverters operating in the  $Q(V)$  modes do not have communications with a network control centre to enable  $Q(V)$  setting changes.

One network utility option to mitigate voltage rise has been to limit solar penetration by limiting individual rooftop PV size, e.g. Western Power applies a 3 kVA limit on single phase solar inverters on houses with a three phase LV supply [2]. Utilities may shift single phase LV prosumer houses experiencing excessive voltages to the phase with the lowest LV voltage, if available.

Another possible network utility option, which this paper evaluates, is to program urban HV/MV substation transformers with line drop compensation (LDC) during daylight hours. LDC is traditionally used on transformers supplying rural MV feeders so that the substation

transformer taps up the sent-out voltage, as the transformer current increases, to partially compensate for voltage drop on long rural feeders. HV/MV transformers with LDC capability (a common feature on rural and newer urban HV/MV substation transformers) can be programmed to lower the sent-out voltage on urban feeders during daytime, when high solar PV output results in light feeder load conditions or even reverse power flow. It is anticipated that the LDC adjustment would need to have a long time constant to avoid excessive tap changing during solar power fluctuations caused by cloud movements [8].

Other utility options, which have been used in Germany, such as distribution connected statcoms to regulate LV feeder voltages or step voltage regulators, are not cheap options and have not been evaluated in this paper. In the case of utility statcoms, the rollout of prosumer solar inverters with statcom functionality could provide similar voltage support benefits. By default, they would be located at the LV feeder extremities, where under and over-voltages are usually worst.

The utility and prosumer options and the combinations of these options will be compared on their ability to mitigate voltage rise, whilst considering other network impacts, such as the consequent reactive power demand and energy losses on an MV/LV urban feeder network. The option of utilising home battery storage to mitigate voltage rise has not been evaluated, as battery storage has the same effect as limiting solar power export by diverting “excess solar power” to the battery. Battery storage provides the primary benefit of time shifting solar energy so that it can be utilised to supply home loads, when there is no solar output. Battery inverters could also provide a statcom function. Battery storage has not been evaluated, as a

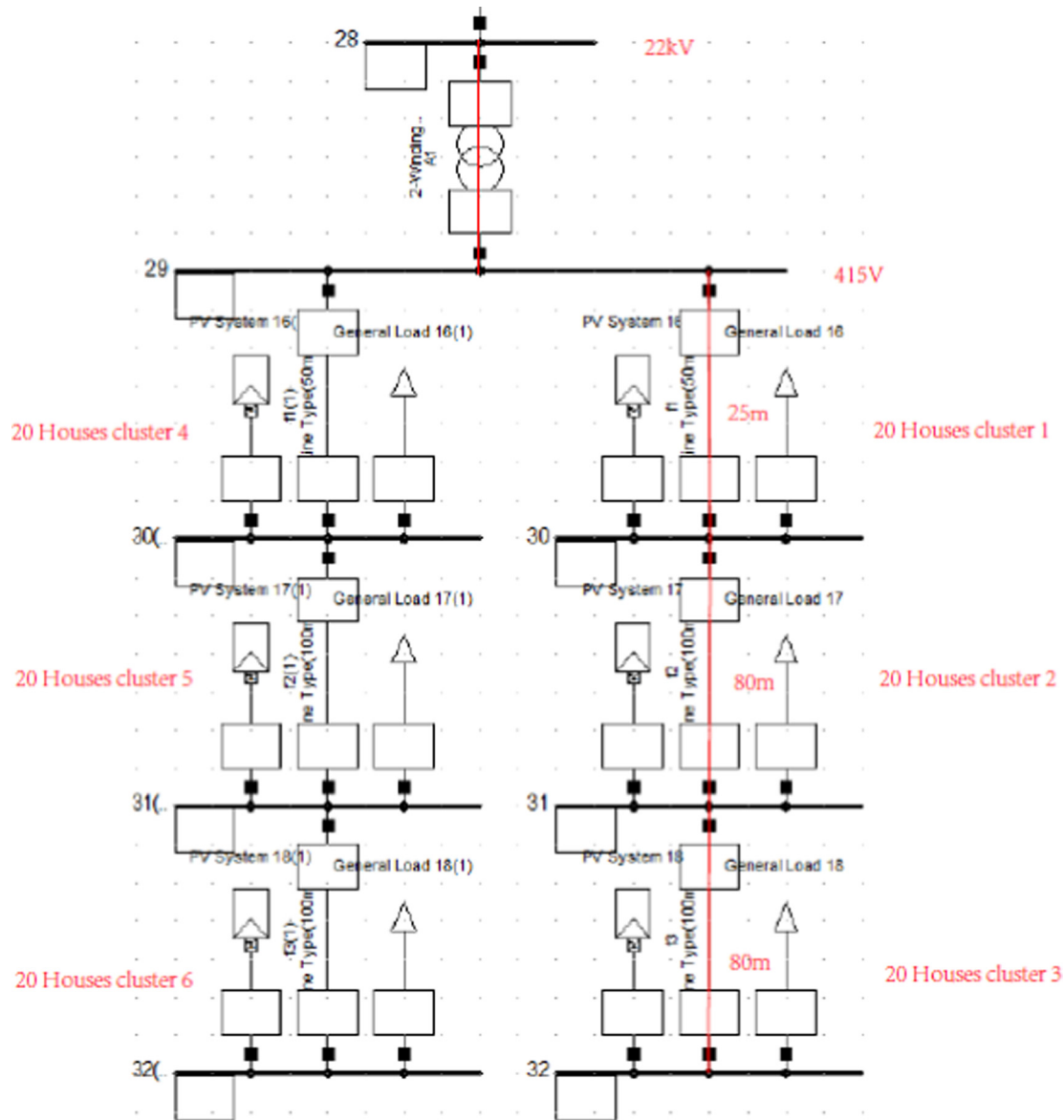

Fig. 2. Highlighted LV feeder of Figure 1 [10].

means of mitigating voltage rise. This paper evaluates options that deal with exported solar power and the statcom function is already being considered, as part of the solar inverter.

## 2 Methodology

To evaluate the effectiveness of the various options of mitigating voltage rise, to allow an increase in PV generation, a representative MV/LV urban feeder was designed and modelled using DlgSILENT PowerFactory version 15.2 software. Distributed rooftop PV generation was added to an example model of an urban feeder to analyse alternative methods to increase urban PV generation. For the purpose of building a representative urban distribution feeder, feeder modelling has taken into account AS3008 [9] for the LV cable data and applied typical MV cable data for the MV cable.

The representative distribution network is shown in Figure 1, with one LV feeder shown enlarged in Figure 2. This network consists of a slack generator behind a source impedance, representing an interconnected grid system. This equivalent “grid” is connected to a 132/22 kV substation containing two 20 MVA 132/22 kV transformers in parallel. A “typical” 22 kV substation urban feeder has been modelled as a 50 mm<sup>2</sup> aluminium 22 kV underground cable that supplies six 630 kVA 22 kV/415 V distribution transformers located at distances of 0.5, 1, 1.5, 2, 2.5 and 3 km from the 132/22 kV substation. Each 630 kVA 22 kV/415 V transformer has an off-line tap changer set to boost the LV voltage by 2.5% and has two 95 mm<sup>2</sup> aluminium 415 V feeder cables connected to it. Each LV cable supplies 60 houses modelled as three “20 house clusters” connected at distances of 25, 125 and 205 m from the 22 kV/415 V transformers.

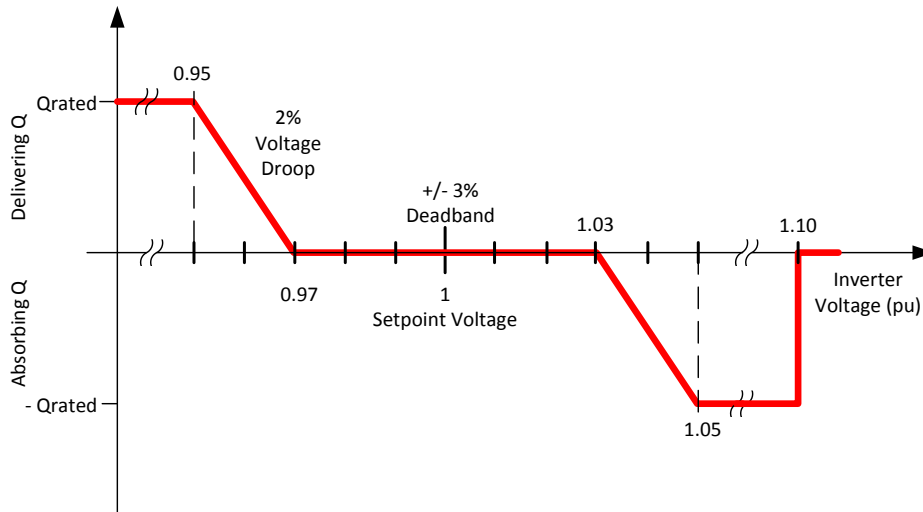

**Fig. 3.**  $Q(V)$  control curve where  $\pm Q_{\text{rated}}$  is limited to a power factor range of  $\pm 0.90$  PF.

**Table 1.**  $Q(V)$  characteristics data (with a deadband).

Voltage droop	Lower voltage limit	Upper voltage limit
2%	0.97 pu	1.03 pu

In the simulations, the network has balanced voltages, as it is assumed that voltage imbalance can be rectified in practice by switching single phase loads and PV generation between phases, where practical.

The peak daytime load base case assumes a maximum daytime load of 4 kVA at 0.85 PF (absorbing) per house or 80 kVA at 0.85 PF (absorbing) per “20-house cluster” and no PV generation. This load scenario represents the maximum load that the modelled MV/LV network could support and supply the most remote “20 house cluster” at 0.95 pu or 5% below the nominal LV voltage. This allows a further 1% voltage drop along the LV cable connecting to each house’s switchboard. The minimum daytime load base case assumes the load is 2 kVA at 0.85 PF (absorbing) per house or 40 kVA at 0.85 PF (absorbing) per “20 house cluster” and no PV generation.

PowerFactory modelling was used to produce voltage profiles for these base cases (no PV generation) and then to produce voltage profiles with increasing amounts of PV generation in 1 kW/house increments up to 5 kW/house and beyond. To represent the current practice in Australia, the solar inverters’ power factor was set to 1 PF (no vars) in the initial studies.

The prosumer options were evaluated and compared by repeating these studies with the solar inverters set to 0.95 PF (absorbing vars), then with the solar inverters programmed with a  $Q(V)$  function and finally with a fulltime  $Q(V)$  function (statcom mode). Table 1 and Figure 3 show the  $Q(V)$  control settings that were selected for the simulations.

These settings, with a  $\pm 3\%$  voltage deadband, are nearly equivalent to having each household solar inverter programmed with a  $\pm 4\%$  voltage deadband, which allows for the  $\pm 1\%$  voltage variation along the LV cable

**Table 2.** 132/22 kV Transformers’ LDC settings in PowerFactory.

Voltage set point	$R_{\text{set}}$	$X_{\text{set}}$
1.00 pu	7	1.4

connecting to each house’s switchboard. These settings provide more voltage support than those proposed in AS/NZS 4777.2:2015, where solar inverters only reach maximum  $Q$  absorption when the LV voltage reaches 265 V, which is more than 10% above the nominal voltage.

The network utility option of using LDC, during the daytime, in the tap change control of the substation 132/22 kV transformers, was then evaluated with solar inverters operating at unity PF, and at 0.95 PF (absorbing). Finally the LDC algorithm was combined with  $Q(V)$  operation of the solar inverters and fulltime  $Q(V)$  operation (statcom mode).

With LDC, the 132/22 kV substation transformers should reduce the sent-out voltage, when the solar power reduces the net daytime feeder load and help offset the voltage rise at the most remote “20 house cluster”. The LDC settings for the two 132/22 kV transformers used in the PowerFactory model (see Fig. 4) are shown in Table 2. These settings were selected so that the  $X_{\text{set}}/R_{\text{set}}$  ratio was similar to the effective  $X/R$  ratio of the MV/LV feeder system. The voltage set point and magnitudes of  $X$  and  $R$  were adjusted so that the 22 kV voltage at the 132/22 kV substation reached 1.02 pu under maximum load, no solar conditions, i.e. identical to the equivalent case without LDC. Also consideration was given to the sensitivity of the setpoint voltage to changes in solar power. The selected settings caused the sent-out voltage to vary from 1.02 pu (maximum daytime load, no solar) to 0.985 pu (minimum daytime load, 5 kW/house of solar).

### 3 Results

For the base case of maximum feeder load (4 kVA at 0.85 PF absorbing per house) and no solar, the most remote “20 house cluster” bus voltage was simulated at 0.948 pu ( $\sim 0.95$  pu).



**Table 3.** Voltages at the most “remote Bus” for the selected prosumer options with 5 kW of solar power/house and 2 kVA at 0.85 PF household loads, without and with the utility LDC option. *Note:* the feeder’s  $P$  (reverse power flow) and  $Q$  demand are also shown for each combination.

Prosumer option	Without LDC			With LDC		
	22 kV substation voltage = 1.02 pu					
	Most remote bus voltage (pu)	$P_{\text{feeder}}$ (MW)	$Q_{\text{feeder}}$ (Mvar)	Most remote bus voltage (pu)	$P_{\text{feeder}}$ (MW)	$Q_{\text{feeder}}$ (Mvar)
Do nothing – solar inverters at 1 PF	1.084	−2.280	0.865	1.049	−2.275	0.873
Solar inverters at 0.95 PF (absorbing)	1.059	−2.226	2.111	1.025	−2.216	2.122
$Q(V) \pm 0.9$ PF (as per Fig. 3)	1.058	−2.213	2.053	1.041	−2.260	1.197

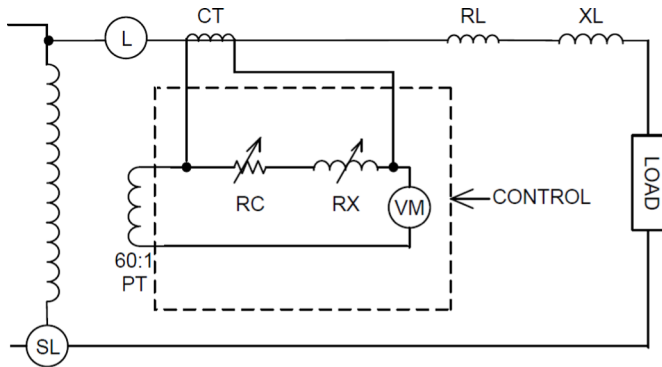

**Fig. 4.** Line drop compensation diagram adapted from Cooper Power Systems [11].

With the solar inverters on every house set to unity PF (current practice) and a minimum daytime house load of 2 kVA at 0.85 PF (absorbing), the simulations showed that with PV output of 3 kW/house, the voltage rose to 1.05 pu at the most remote “20 house cluster”, increasing to 1.084 pu with 5 kW/house – well above the acceptable limit (see Tab. 3).

The simulations were repeated with solar inverters set to 0.95 PF (absorbing vars) and 4 kW/house of solar power and resulted in voltages at the most remote house cluster remaining below 1.05 pu. With 5 kW/house this voltage increased to 1.059 pu – just above the acceptable limit (see Tab. 3).

The next evaluated prosumer option is solar inverters operating with a  $Q(V)$  function. Using the proposed  $Q(V) \pm 0.9$  PF with  $\pm 3\%$  voltage deadband settings (2% voltage droop outside deadband), the 4 kW/house case resulted in voltages remaining just below 1.05 pu and 5 kW/house causing the voltage to reach 1.058 pu. These results are very similar to the case with all inverters operating at 0.95 PF (absorbing). Whilst the solar inverters in the  $Q(V)$  option have a greater  $Q$  range ( $\pm 0.9$  PF) compared to the 0.95 PF (absorbing) option, they only commence absorbing  $Q$  when their terminal voltages rise above the voltage deadband. The  $Q(V)$  option slightly reduces the feeder’s  $Q$  demand by 48 kvar (2.111 – 2.053 Mvar) compared to the 0.95 PF (absorbing) option (see Tab. 3).

The most technically advanced prosumer option of having all inverters capable of providing a fulltime  $Q(V)$  function (statcom mode) was simulated, assuming each

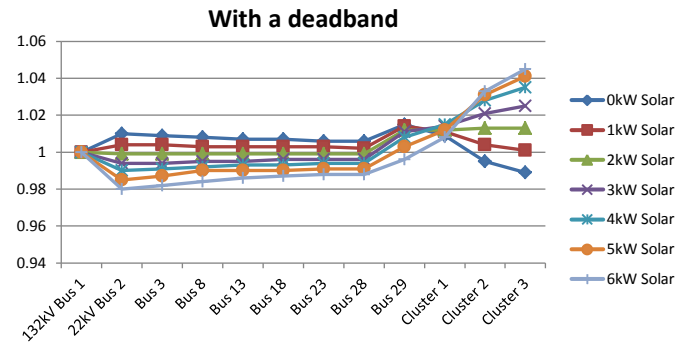

**Fig. 5.** Voltage profiles starting from the 132/22 kV substation through to the most “remote Bus” for the combination of the  $Q(V)$  and LDC options and household solar power levels from zero to 6 kW.

house had a 5 kW solar inverter with a fulltime  $Q$  range equivalent to  $\pm 0.9$  PF operation at 5 kW, i.e.  $\pm 2.42$  kvar. The voltage deadband and voltage droop settings were kept the same as at the previous  $Q(V) \pm 0.9$  PF case. The simulations showed that the effect of operating the 5 kW solar inverters as statcoms during maximum load and no solar output conditions was to raise the minimum LV feeder voltage by around 1% from 0.948 to 0.957 pu, effectively increasing the maximum load carrying capacity of the LV feeder.

The utility option of using daytime LDC, with the settings previously described, was simulated in combination with the selected prosumer options.

Table 3 shows the effect of introducing LDC. With solar power at 5 kW/house and a minimum daytime house load of 2 kVA at 0.85 PF, the substation 132/22 kV transformers are experiencing reverse power flow. Hence the LDC has adjusted the setpoint voltage of the 22 kV voltage at the 132/22 kV substation below 1 pu – in this case down to 0.985 pu.

The addition of LDC significantly reduces the voltage rise when combined with the prosumer options (see Tab. 3). The combination of the 0.95 PF (absorbing) option and LDC resulted in the lowest voltage rise (1.025 pu), however the combination of the  $Q(V)$  option and LDC, which produced a voltage rise of 1.041 pu, reduced the feeder’s  $Q$  demand by 925 kvar (2.122 – 1.197 Mvar), compared to the combination of the 0.95 PF (absorbing) option and LDC. The  $Q(V)$  option and the fulltime  $Q(V)$  option (statcom

mode) produced identical results with the solar inverters operating at rated power output – as they are in the simulations that produced the results in Table 3. Figure 5 shows the simulated feeder voltage profiles starting from the 132/22 kV substation through to the most “remote Bus” for the combination of the  $Q(V)$  and LDC options, with solar inverter output (and rating) levels from zero to 6 kW per house. This figure demonstrates the effect of the LDC lowering the substation’s sent-out voltage as the level of household solar increases, thus offsetting the voltage rise at the most remote Bus.

## 4 Conclusions

Combining selected prosumer and utility options has the potential to provide effective means of mitigating voltage rise and so allow for very high solar penetration, i.e. every dwelling that can accommodate rooftop solar can have rooftop solar.

Operation of solar inverters at 0.95 PF (absorbing vars) rather than unity does reduce voltage levels but this mode places a significant extra reactive power burden on the network. The fixed reactive power absorption is especially undesirable, if network voltages are low. Also  $Q$  absorption near the start of an LV feeder has little benefit in reducing LV voltages.  $Q$ -loading at the start of the feeder has little benefit [12].

The operation of the solar inverters with a  $Q(V) \pm 0.9$  PF function with deadband according to Figure 3 reduces voltage rise by a similar amount but is responsive the voltage levels. As the network voltages decrease, the inverters absorb less  $Q$  (or none if terminal voltages are between 0.97 and 1.03 pu) and begin  $Q$  export if terminal voltages fall below 0.97 pu. The fulltime  $Q(V)$  option provides continuous voltage support, which reduces LV voltage variations and increases LV feeder voltages under high load conditions, thus enhancing the feeder’s load carrying capacity. The selected  $Q(V)$  deadband and droop settings mean that the solar inverters’  $Q$  (absorption) capacity is fully utilised in trying to prevent voltage rise exceeding 1.05 pu (20 house cluster) or 1.06 pu (house switchboard). The latter equates to 254 V in Western Australia. These settings make better use of solar inverter capabilities than the proposed settings (disabled by default) in AS/NZS 4777.2:2015, which ramp up a solar inverter’s  $Q$  absorption over the voltage range 250–265 V (27% of  $Q$  capacity utilised at 254 V).

LDC appears an effective means of mitigating voltage rise and combining it with  $Q(V)$  or fulltime  $Q(V)$  means that the inverters are absorbing less  $Q$  under high solar conditions. The slow acting LDC is effectively automatically reducing the  $Q$  loading of the fast acting solar inverters and therefore reducing the reactive power demand of the feeder.

The addition of LDC to the  $Q(V)$  option or the fulltime  $Q(V)$  option appear to be a good combinations in terms of reducing voltage rise without drawing excessive reactive power under high solar conditions. The slow acting LDC

effectively reduces the reactive power loading of the solar inverters so that they can maintain their fast voltage support. The fast acting solar inverters will also help support feeder voltages whilst the LDC function operates with a long time constant to avoid excessive tap changing during cloud movements.

## References

- Standards Australia, Standards New Zealand, *AS/NZS 4777.2:2015 Grid connection of energy systems via inverters – inverter requirements* (SAI Global, Sydney, 2015)
- Western Power, Technical Guidance for Solar Installers (2017), Available from: <https://www.westernpower.com.au/support/technical-guidance-for-solar-installers/> (accessed on: 2017/12/01)
- D. Condon, D. McPhail, Voltage regulation of distribution networks using inverter reactive power functionality – Australian utility experience, in *Proceedings of the IEEE PES Asia-Pacific Power and Energy Engineering Conference, APPEEC, Brisbane* (2015)
- J. Croker, Transactive energy for voltage support within residential grids with a high penetration of photovoltaics: a co-simulation analysis, Masters dissertation, Murdoch University, 2016
- E. Demirok, D. Sera, R. Teodorescu, P. Rodriguez, U. Borup, Clustered PV inverters in LV networks: an overview of impacts and comparison of voltage control strategies, in *Proceedings of the 2009 IEEE Electrical Power and Energy Conference, EPEC 2009* (2009)
- P. Jahangiri, D.C. Aliprantis, Distributed Volt/VAR control by PV inverters, *IEEE Trans. Power Syst.* **28**, 3429 (2013)
- A. Maknouninejad, N. Kutkut, I. Batarseh, Z. Qu, Analysis and control of PV inverters operating in VAR mode at night, in *Proceedings of the IEEE PES Innovative Smart Grid Technologies Conference Europe, ISGT Europe* (2011)
- T.L. Lee, S.S. Yang, S.H. Hu, Design of decentralized voltage control for PV inverters to mitigate voltage rise in distribution power system without communication, in *Proceedings of the 2014 International Power Electronics Conference, IPEC-Hiroshima – ECCE Asia 2014* (2014), p. 2606
- Standards Australia, *AS3008.1.1:2009 Electrical installations – selection of cables – cables for alternating voltages up to and including 0.6/1 kV – typical Australian installation conditions* (SAI Global, Sydney, 2009)
- P. Lu, An investigation into voltage control approaches on an example distribution feeder to increase PV penetration, Bachelor of Engineering Honours thesis, Murdoch University, 2015
- Cooper Power Systems Inc., *Bulletin 77006: how step-voltage regulators operate* (1993), Available from: [http://www.cooperindustries.com/content/dam/public/powersystems/resources/library/225\\_VoltageRegulators/77006.pdf](http://www.cooperindustries.com/content/dam/public/powersystems/resources/library/225_VoltageRegulators/77006.pdf), accessed on: 2017/12/01
- E. Demirok, P.C. González, K.H.B. Frederiksen, D. Sera, P. Rodriguez, R. Teodorescu, Local reactive power control methods for overvoltage prevention of distributed solar inverters in low-voltage grids, *IEEE J. Photovolt.* **1**, 174 (2011)