

DISTORTION OF SPEED CHANGER HOUSINGS AND RESULTING GEAR FAILURES

BY

Fred L. VanLaningham

Senior Staff Engineer, Systems and Machinery Management

Union Carbide Corporation

Chemicals & Plastics

South Charleston, West Virginia



Fred VanLaningham is a senior staff engineer, Systems and Machinery Management, Union Carbide Corporation's Engineering Center, at South Charleston, West Virginia.

He has worked with Union Carbide for more than 23 years in several positions in Maintenance, Construction, and Engineering and is presently senior staff engineer with the Mechanical Technology Group (a mechanical equipment reliability oriented group) following application of large process machinery from specification, through evaluation, purchasing, manufacturing and testing to installation, commissioning and startup.

He has completed numerous troubleshooting and problem diagnosis assignments related to large rotating machines, including high speed gearing, centrifugal compressors, and gas and steam turbines, at Union Carbide plants of both the Chemicals and Plastics and Linde Divisions.

ABSTRACT

Gear case distortion due to thermal effects has caused unique and costly failures at several of Union Carbide's process plants. The unusual nature of these failures has prompted us to make an in-depth logical investigation considering the most obvious as well as the not so obvious reasons for failure.

Diagnosis indicates that distortion of the housing due to temperature variations, including changes in ambient and the design of the internal lubrication and gear mesh cooling spray, is more significant than previously suspected. Several examples illustrating the problems and their solutions, including the field mechanical and optical measurement methods, are discussed.

INTRODUCTION

Union Carbide Corporation has experienced problems resulting from gear case or housing distortion of both speed increasers and speed reducers installed in its chemical process and air separation plants. Many of the resulting gear and bearing failures were not totally explained until the presence of certain factors of a similar nature were recognized as a part of each failure.

Thermal distortion of the housing or case due to the design of internal lubrication and gear spray systems, radiation from connected equipment, and rapid changes in atmosphere conditions and temperatures were recognized as contributors.

The failures were not limited to fabricated housings nor were they limited to any typical design. We had problems with

spur, single helical, and double helical gear sets in cast and fabricated housings. Units with service factors of from 1.3 up to 2.0 were subject to failures that were unusual and difficult to diagnose.

RECOGNITION OF PROBLEM

The first failure that was recognized as the result of housing thermal distortion occurred on a fabricated housing of side bar type construction. It is a large, single helical, multipinion unit and is located in one of our Gulf Coast plants. This unit connects five machines: three compressors, a turbine, and a motor/generator. The gear is seven feet in diameter, and the pitch line velocity is 26,389 ft/min. Figure No. 1 illustrates the unit. The pinions have taper land thrust bearings in the direction of normal thrust and the low speed gear at time of failure had taper land bearings in both directions since its direction of thrust was determined by the power output or input combination at the various shafts. The failure was wiping of both thrust

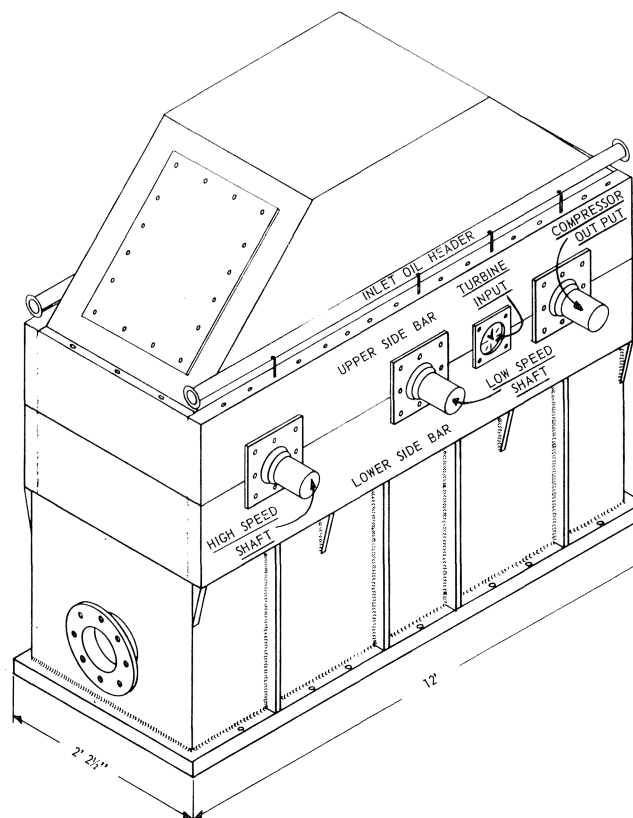

Figure 1. Triple pinion single helical gear speed increaser/reducer showing base plate at extreme bottom of enclosure.

bearings on the low speed gear. The thrust clearance was considered adequate for distance between thrust faces and assuming normal thermal growth of the gear shaft relative to the housing. Lubricating oil was supplied from a console common to the entire compression system. Two external pipe headers were mounted above the horizontal split line of the housing and ran the full length of the housing. Bearing temperature detectors were mounted in the bearings; also noncontacting vibration monitors were installed.

The low speed bearing temperatures were higher than expected when the unit was first operated and exhibited minor excursions in both directions. However, they were not at what was considered an alarm or danger point. After a short period of operation (about six weeks), the temperatures moved up in a matter of minutes forcing a shutdown of the system.

The housing was disassembled and the babbitt thrust face of both low speed bearings were badly wiped. Wiping had also occurred on the inboard side or next to the thrust faces of both journal bearings. Prior to the failure, the system was operating normally and nothing unusual was noted. The most probable cause for such a failure is insufficient thrust or axial clearance. Clearance had been checked and recorded during the post-mechanical running test inspection at the builder's plant and again after installation at the job site. The only clue to the cause of failure was that during the time thrust bearing temperatures were rising, thunder showers were occurring. We concluded that this failure was caused by thermal bowing inward of the housing side bar sections thus decreasing the axial or thrust clearance. The higher temperature inside of the housing due to windage, hot oil mist, etc., relative to the outside of the housing had caused the housing side bars to bow resulting in a loss of clearance. The higher temperature inside of the housing due to windage, hot oil mist, etc., relative to the outside of the housing had caused the housing side bars to bow resulting in a loss of clearance. The higher than normal thrust bearing temperatures we had experienced resulted from the heavy Gulf Coast thunder shower cooling the exterior, increasing the temperature differential, and resulting bowing enough to totally wipe out both thrust faces. Figure No. 2 indicates the side bars bowing.

The unit was repaired temporarily with replacement bearings machined for increased axial clearance plus insulating the entire outside surface of the housing. The manufacturer then redesigned the low speed bearing arrangement changing from the plain journal bearings with taper land thrust faces to two double element type TDO tapered roller bearings. The unit on the main oil pump side was fixed, and the unit on the motor generator side floating. The calculated life of the roller bearings is about 125 years. After modification, the insulation on the exterior of the housing was removed.

This unit has been operating continuously since 1969 with no further problem due to thermal bowing.

A smaller motor driven, 5000 HP double helical speed increaser, installed outdoors at one of our northern plants wiped both low speed thrust faces during initial startup. As before, this gear set had been given a successful mechanical run test and post-test inspection at the manufacturer's plant. All clearances were again checked and recorded during installation.

The initial startup of the gear speed increaser took place in late January 1970, and the ambient temperature was -20°F . The previous experience with the multipinion unit led us to an immediate simple solution. The axial float or thrust clearance was increased to compensate for the inward bowing of the housing. The system was then operated with no further bearing problem.

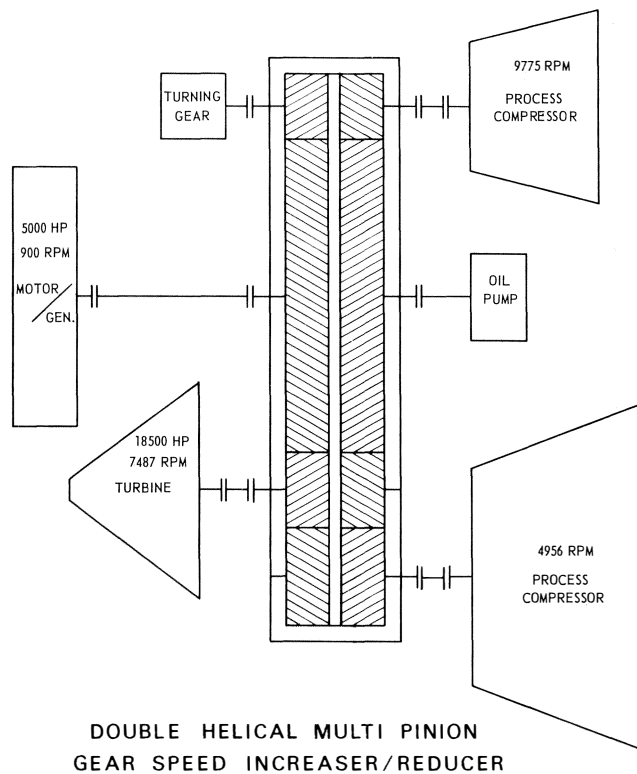

DOUBLE HELICAL MULTI PINION
GEAR SPEED INCREASER/REDUCER

Figure 2. Plan view of triple pinion single helical unit showing connected equipment and inward bowing of both side bars toward low speed gear.

The two units just described are examples of a simple thermal distortion problem.

COMPOUND PROBLEMS ARE RECOGNIZED

Installed in another of our northern plants are three identical high speed (25,910 ft/min.) pitch line velocity double-helical speed increaser units, each connecting a gas turbine to a compressor train consisting of two compressors and a steam helper turbine. Two of the units are installed indoors with a relatively constant ambient temperature while the third is installed outdoors. The two units installed indoors had, after 23,100 and 23,500 hours of service, experienced gear failures.

The number two unit which failed first after 23,100 hours of operation had teeth broken out of the pinion near the apex on the input or turbine side helix. The gear teeth were pitted near the apex on the loaded flanks of the input or turbine helix.

The number one unit failed after 23,500 hours of service and had teeth broken out of the pinion near the apex on the input or turbine helix as shown in Figure 3. In addition to the pitting, which was similar to the number two unit, near the apex on the loaded flanks of the gear, pitting was also evident near the edge on the output or compressor helix as can be seen in Figures 4 and 5.

The gears had no doubt failed due to an internal alignment difficulty that had concentrated the load resulting in localized fatigue failure. Distortion of the housing, its foundation, or barreling of the gear and/or pinion in the center due to nonuniform heat rejection from the gears were possible causes.

Thermal distortion, "barreling," of the pinion was assumed to be the major cause for failure, and distortion of the housing or its foundation were considered as candidates for compounding the problem.

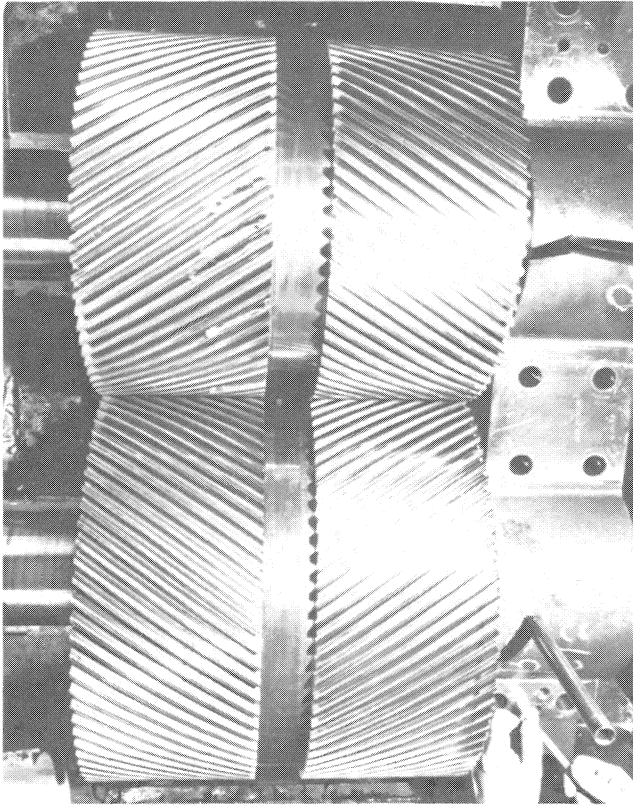

Figure 3. Photograph of failed double helical speed increaser gears as upper half of housing was removed. Fatigue breakage is evident on pinion.

Lockup of the pinion to compressor coupling was another possible cause. If the coupling were to seize or lock as the unit was being brought up to temperature, the thermal expansion of the compressor shaft from its thrust bearings toward the gear could cause increased loading of one helix while unloading the other. The input or turbine helix would be loaded in this manner. If this were the case, why then did we have pitting on both helices of the gear?

Studies were conducted by us simultaneously with the manufacturer as to adequacy of the gear design, tooth strength in beam bending, surface durability, and lubrication including how mesh cooling and lubrication spray were accomplished. Records of the tooth contact, alignment and clearances were checked, and the housing was physically checked for out of parallelism of the bearings bores that could result from grout swelling, loosening of anchor bolts or relaxation of residual stress within the housing. The bearing bores were parallel and further housing checks disclosed nothing.

Barreling of the pinion remained the prime suspect. Modifications were made to the gear mesh spray system adding sprays to the out of mesh side as well as into mesh with an additional set of spray nozzles spraying the face of the pinion 180° from the mesh, and the oil pressure to the unit was increased. After 5000 hours the number two unit was inspected, and severe pitting near the apex at the pitch line was found on the replacement gears.

Why did only the units installed indoors exhibit the apparent barreling problem, while the trouble-free third unit installed outdoors was consistently more heavily loaded? The answer was obvious once we reviewed the differences in the installations. A simple screen that had been added to the out-

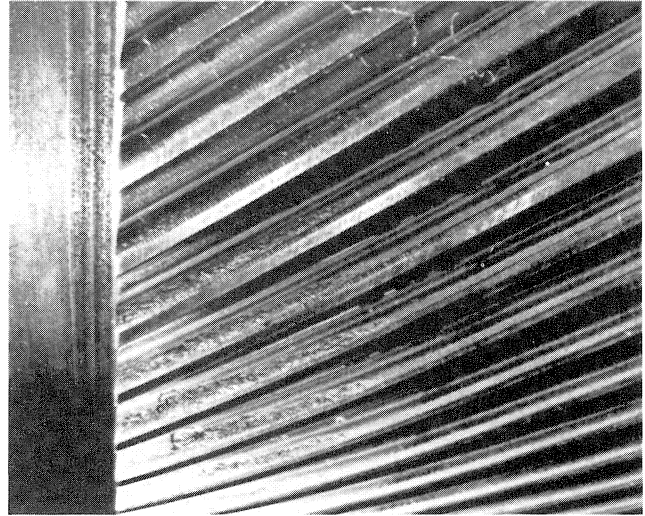

Figure 4. Photograph of low speed gear turbine side helix loaded flanks showing destructive pitting and spalling.

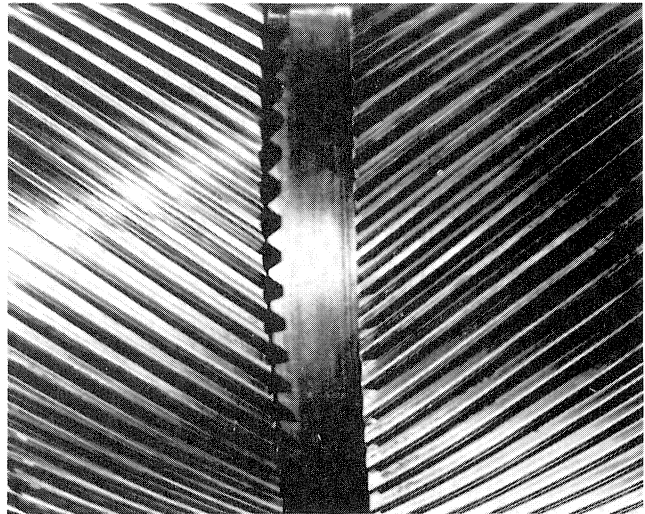

Figure 5. Photograph of low speed gear showing pitting on loaded flanks of both helices. Additional markings on compressor side helix can be seen in lower right hand corner.

door installation was shielding the gear housing from the heat radiated by the hot end of the gas turbine. The radiant heat was causing the horizontal center distance to increase on the side nearest the turbine; also the vertical thermal growth was greater at one shaft than the other resulting in the gear and pinion centerlines being out of parallel in two planes during operation. This altered the tooth contact and concentrated the load near the apex.

A shield was installed in addition to the previous lubrication and cooling spray modifications. The units have operated continuously except for planned preventive maintenance for the past six years with no reoccurrence of the failures. Routine inspections of the gears indicate excellent tooth contact and no further indications of distress.

CHRONIC PROBLEMS WITH A COMPLEX UNIT

Two high horsepower, multipinion, double helical, high speed (22,619 ft/min.) units installed outdoors at a Gulf Coast plant have been in operation for several years. The housings

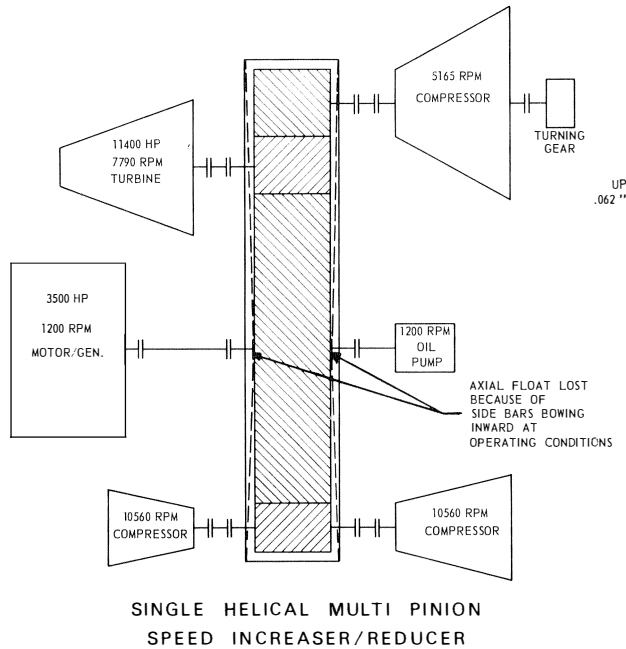

Figure 6. Plan view sketch of triple pinion double helical speed increaser/reducer showing connected equipment.

are fabricated and are of side bar type construction. Two centrifugal compressors, a turbine, and a motor/generator are connected to the gear set with grease packed flexible couplings (See Figure 6).

Problems have been gear tooth contact changes, tooth breakage due to edge loading, gear tooth spalling and pitting at the pitch line, and bearing failures. One major problem has been excessive wear and worm tracking of the flexible couplings teeth connecting the equipment in the system. Only one failure of a low speed journal bearing resulting in edge loading and tooth breakage of the gear and two of the pinions and a broken main oil pump drive shaft on one of the two units has been totally explained.

Other failures remained a mystery. Coupling alignment has been checked using all of the conventional methods. The alignment has never been consistent from one check to the next causing us to discredit the validity of the measured values. The following methods have been used to check the shaft to shaft coupling alignment from cold static condition to dynamic running at full load operating conditions:

1. Shaft to shaft with dial indicators.
2. Inside micrometers or measuring rods from targets fixed at each side of each bearing to targets on the soleplates.
3. Temperature gradient checks with thermocouples and chart recorders.
4. Noncontacting proximity probes mounted on water cooled stands at each coupling.
5. Brackets or bars mounted on each machine, spanning the space in both directions across the couplings and measuring their relative movement with proximity probes, dial indicators, and feeler gages.
6. Optical alignment telescopes and optic scales.

Each method failed to produce conclusive data.

Shaft to shaft with dial indicators taking both reverse indicator readings and face and rim measurement produced inconsistent results. Even with the very best of planning, dedi-

cated and skilled mechanics, and the proper tools available, it is nearly impossible to get an accurate "hot check" of coupling alignment. The instant the unit is tripped and starts to coast down, the temperature of the machines starts changing. By the time the dial indicators are clamped to the shafts, even if the coupling spacer spool remains in place, the change has continued. The mechanics can rotate the shafts, obtain and record one set of readings, then make another revolution to check their findings, and the values will have changed.

Measurements with inside micrometers or crankshaft deflection gages measuring from spots center punched on the top of soleplates to spots center punched on similar targets mounted on each side of the bearing centerline of the machines were made while static and in operation. These measurements were the most consistent of all and perhaps caused us to fail to recognize that gross misalignment was occurring.

The output of a series of thermocouples embedded in drilled holes in the foundation, cemented onto the frames and supports of the machines was recorded on a continuous recorder from cold start until after several days of operation to assure that the system was thoroughly "heat soaked." We hoped to establish the thermal movement for each small section and use this as a check against our other measurements. The sensitivity of the recording system was such that we could detect the effect of passing clouds on a sunny day, sudden thundershowers, and changes from day to night. This proved to be an exercise in data collection. From that standpoint it was a success.

The DC voltage from noncontacting proximity probes mounted on water cooled pipe stands anchored into the foundation and monitoring the position of the shafts rendered a wide range of values. The probe mounting brackets installed on the water cooled stands would distort from radiant heat, and the stands were buffeted by windage from the open bottoms of the coupling guards. Mechanics, operators, and just about anyone that would venture out to have a personal look at the situation would eventually use the stands as handholds, grab irons, and as access steps, at times rendering the readings useless.

Brackets mounted on each machine bolted at one end, and spanning the space in both directions across the coupling spools to the connected machine were used. Two brackets were required for each coupling. Three types of measurements were made using brackets of this nature. Dial indicators, feeler gages, and proximity probes were all used. All values were different. None of the readings would repeat with the accuracy necessary.

Optical alignment checks were performed by us and also by a firm that specializes in optical alignment of rotating machinery. The values were truly unbelievable and to get believable numbers, changes were made in the procedures used. Cold and hot readings were made only between 10:00 p.m. and 2:00 a.m. to minimize solar effects. Cold reference readings were made using both the reverse indicator method and the face and rim method with dial indicators. The results of each check were "fantastic" indicating that the compressors had shrunk after being brought up to operating temperature.

Discussion followed with experts from the optical alignment firm and the manufacturers of each piece of rotating equipment in the connected system. We contacted other users of the same size compressors operating at similar temperatures including three installations at other plants within our own corporation. The thermal movement values recorded at our other locations, recorded by other users, and reported by the manufacturer were consistently very close to the manufacturer's predicted values.

A review of the values of the optical readings was held with experts from the optical alignment firm. The gear had been considered a fixed point of reference for each of the four couplings, and the bases for establishing the values for realignment to an optimum value was the relative difference of each as measured optically.

Reviewing the measured data from all sources plus the information from other installations indicated that if the compressors were growing thermally as predicted, then the gear was moving nearly six times its predicted growth. The hot and cold elevation of the compressors was established as the base, and the gear set assumed to change differently than predicted. The assumption indicated that this 14 foot long gearbox was bowing up at each end or actually "curling up its toes" by as much as 0.062 in. to 0.090 in. Temperatures of nearly 900°F would be required to cause an increase in the height from the soleplate to centerline of that magnitude. Inside micrometer measurements from the soleplate to gearbox centerline did not indicate such movement.

Discussions continued with the optical experts, and additional measurements of the gear were made. More than fifty targets or reference points were permanently mounted on the gear housing in preparation for the optic check to confirm whether the housing was distorting or not. The results indicated that it was distorting by bowing up at each end, the side rails were bowing inward, and the unit was twisting.

The gearbox was bolted to the grouted soleplate with 1-3/4 in. hex head cap screws. They were found to be tightened properly, but we discovered that the soleplate was moving up with the box. This was the reason the inside micrometer checks from the centerline to soleplate were relatively consistent and clouded the cause of the actual distortion. The grout had failed, and some of the anchor bolts were no longer at original stress or torque values. One anchor bolt had failed.

DEFINING THE ACTUAL PROBLEM

The inward bowing of the housing side rails was assumed to be the result of the temperature differential between the inside of the unit and the outside ambient, since two units had previously exhibited this and the conditions were similar.

The reason for the ends bowing up was not clear. This condition had not been suspected before on these or any other units. The similarities and dissimilarities in design, installation, and operation were tabulated; and the one difference that was recognized was the design of the internal lubricating and gear cooling spray system.

Three gear manufacturers were contacted plus a consultant or gearing for assistance in diagnosing the probable cause. We had housing distortion problems with units manufactured by each of them and the consultant had assisted us before. No history of or experience with gearboxes bowing up at the ends was available. Our consultant on gearing and each manufacturer including the builder of the unit in question cooperated with us and each other fully to expedite a solution.

The bowing, we thought, most probably was the result of a temperature difference between top and bottom halves of the housing. How this condition could exist became clear when the lubricating oil header design was reviewed. The filtered and cooled oil entered at one end of the housing just above the horizontal centerline, i.e., the upper half. Once the oil entered the inlet nozzle and passed through the housing, the flow divided equally to each side into two identical oil headers. The headers were formed by two 1-1/2 in. by 5 in. channels welded to the inside of the two upper side bars or rails and ran the full

length of the housing. The side rails formed the fourth side of the channel. The porting for bearing oil was drilled through the side rails and into the chamber formed by the channels while the mesh sprays were mounted on pipes that crossed the box and connected the two chambers together. At the opposite end of the unit from the inlet were ports drilled and tapped with pressure gages installed.

The lower rails of the housing were clear except for oil return holes to drain the oil from the bearing end covers or shaft seal cavities back into the housing.

The inlet oil temperature was normally held at 115°F to 130°F. The housing temperature as measured with a surface pyrometer was, with the exception of a few hot spots, about 30°F to 50°F higher than inlet oil temperature everywhere except for the two upper side rails. They were at or about 3°F above inlet oil temperature. What we had was similar to a huge bimetallic thermostat. The number, diameter, and length of the split line bolts were such that the horizontal joint did not slip but would bow with the ends moving in the direction of the lower temperature. The channels also formed a flow interruption at the inside of the housing causing a further increase in temperature due to windage.

REDESIGN TO ACHIEVE A SOLUTION

Redesign of the internal lubrication and cooling system was relatively simple. The channels welded to the rails were removed, and two full length pipe headers were welded into the end panels that were relatively thin compared to the heavy rails. Jacketed braided hoses were connected and tack welded to prevent loosening to threaded couplings welded into the pipe headers. Both faces of every mesh are sprayed. Sixty spray nozzles cool and lubricate the three meshes of the four gears. See Figure 7.

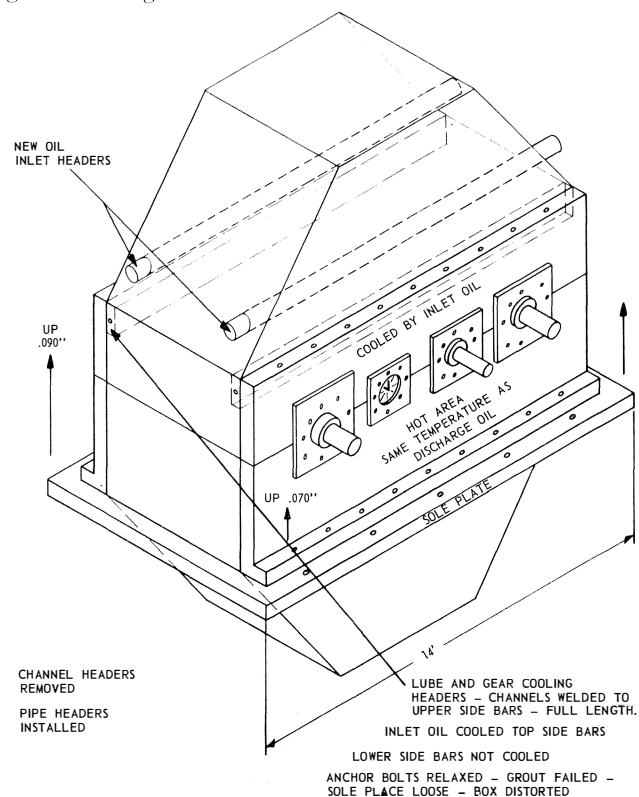

Figure 7. Triple pinion double helical unit indicating cut over sole plate mounting and location where distortion was greatest plus location of original and as modified oil inlet headers.

Although the pipe headers are cooler than the housing and expand less than the housing, the "thin" end panels act as diaphragms to absorb the difference. We assume that the pipe headers cause less of a flow interruption to the windage from the gear.

After modification of the housing, the grout was chipped out, the soleplates removed, optically leveled, and regouted with epoxy resin grout. The units also had bearing metal temperature detectors and noncontacting vibration probes installed while the modifications to the lube system was being done. Both units as reinstalled are monitored continuously.

Work is continuing to confirm the effectiveness of the "fix" and the predicted thermal effects on the coupling alignment.

CONCLUSION

We, as a user, have experienced many other types of gear failures and now request via the purchase order all necessary data to perform a complete design audit of the gear set. The audit may be done either in-house by us or by outside consultants with our participation plus the manufacturer's participation. It has been necessary to modify their standard offerings at times to achieve suitable units for our requirements. An example of some of the data requested is as follows:

1. Gear Mechanical Evaluation Data
 - A. Gear data for each gear
 1. Diametral pitch
 2. Helix angle
 3. Pressure angle and tooth form
 4. Center distances
 5. Number of teeth
 6. Face width
 7. Material
 8. Surface hardness and depth
 9. Core hardness
 10. Weight and mass moment of inertia
 11. Lateral critical speed
 - B. Shaft dimensions. Sketch showing:
 1. Diameter and tapers
 2. Locations of changes in diameter
 3. Locations of attached masses (gears, thrust collars, etc.)
 4. Locations and dimensions of spacer sleeves
 5. Location of bearings
 6. Shaft material and average operating temperature of shaft
 7. Location and size of keyways and helix angle orientation of gears
 - C. Attached masses
 1. Weight of each
 2. Axial and diametral mass moments of inertia
2. Radial Bearing Data
 - A. Type and size (length and diameter)
 - B. Radial clearance
 - C. Oil film stiffness and damping coefficients
 - D. Oil pressure to bearings, psi
 - E. Oil temperature entering and leaving bearings, °F
 - F. Support stiffness

- G. For tilting pad bearings provide:
 1. Number of pads
 2. Included angle of pads, degrees
 3. Pivot position relative to pad center
 4. Preload factor (1-C'/C)
 5. Load position (on pad or between pads)
 6. Pivot point radial stiffness, lbs/in.
- H. Number, orientation, and included angle of grooves in multiple axial groove bearings
- I. Number, ellipticity, and included angle of lobes in lobed bearings
- J. Groove orientation, width, depth, and included angle for pressure dam type bearings
- K. For ball or anti-friction bearings, provide manufacturer and number, ball diameter, number of rollers or balls, radii of curvature of inner and outer races, contact angle, and axial preload.

* Stiffness and damping coefficients should be given at various speeds. If not given, calculated values will be used.

3. Thrust bearing type, size, and unit loading
4. Coupling Data
 - A. Spacer length
 - B. Weights and centers of gravity
 1. Each hub
 2. Spacer
 3. Flanges, bolts, etc., at each end
 - C. Polar mass moment of inertia of each coupling half
 - D. Torsional spring constant*
 - E. Distance centerline to centerline of gears or diaphragms
 - F. Cross-section moment of inertia or OD and ID of spacer
 - G. Lockup torque for gear couplings
 - H. Axial and bending flexibilities for diaphragm type
5. Possible sources and frequencies of excitations

* Torsional spring constant should be from point of entry of shaft into coupling hub on each end and assuming one-third of shaft in each hub is free to twist.

In addition to these data, we have Quality Assurance documentation requirements which are a means of emphasizing the importance of Quality Control. They are intended to provide essential "as-built" data for the critical components and are included in the purchase specifications and discussed in detail with the vendor. Our General Specifications for Gears and Quality Assurance Documentation Requirements both call out the minimum requirements for shop mechanical spin testing, post-test inspection, and preparation for shipment. In spite of these requirements and checks pertaining to the dynamic parts, problems have originated with the static members that have dramatically affected the units.

More attention is now being given the housing and the installation than before in an effort to eliminate the problem of distortion. Each user should be equally aware of the effects of connected equipment, internal lubrication and cooling systems, indoor or outdoor installation, plus any unique features that affect the housing and can dramatically reduce the life of the gear set regardless of its service factor or how well the gears were manufactured.

Another check that is desirable is to shut a newly installed unit down for a recheck of the tooth contact pattern after it has

been brought up to load, speed and temperature for a few hours or as long as necessary for the temperature to stabilize. If the contact pattern from the loaded run so indicates, it may be necessary to actually internally misalign the gears by unequal shimming and warping the housing to compensate for the housing distortion. This is not different than the accepted practice

of cold coupling misalignment of connected machines to compensate for their individual housings movements.

It is hoped that we have passed along experiences that will tend to give those who build, specify, and use gears an understanding of the importance of attention, equal to that given the gears, be applied to the gear case or housing.

