

TURBOMACHINERY PROBLEMS — LUBE AND SEAL SYSTEM REVISITED

by

Royce N. Brown
 Consulting Engineer
 Dow Chemical U.S.A.
 Houston, Texas



Royce N. Brown is a consulting engineer with Dow Chemical U.S.A., Engineering and Construction Services, Houston, Texas. His responsibilities include specifications, consulting and field assistance in the area of large rotating equipment for Dow worldwide. He holds a Bachelor of Science degree in Mechanical Engineering from the University of Texas and a Master of Science degree in Mechanical Engineering from the University of Wisconsin. He is a fellow member of ISA, a member of ASME, a member of API, and is a registered professional engineer in Texas, Louisiana, Wisconsin and California.

ABSTRACT

Even an apparently well-designed lube and seal system can and will cause turbomachinery problems to occur if all operating parameters are not considered in the design of the lube and seal system. Lube and seal system design, fabrication and installation have made great progress in basic design in the past decade. The introduction and use of API 614 has made its contribution. However — despite these advances — periodically turbomachinery suffers unscheduled outages — sometimes major damage due to the loss of lubricating oil. The paper will discuss some of the problems experienced in the past several years.

INTRODUCTION

Much has been said on the subject of the design, operation, and malfunction of lube and seal oil systems. Problems with either of the above, unfortunately, are not self-contained. That is to say, problems on the oil supply system are reflected as part of the reliability of a turbomachinery train. It should be self-evident that the loss of lubricating oil to an operating turbomachine can, and usually has, catastrophic results. The damage to the machine and the resulting lost production in most cases far exceed the cost of a lube and seal system. Previous papers [1, 2] have discussed some of the design problems, specifications, and components.

There has been much progress made in the field of lube system design, startup, and operation. API 614 [3] has had its positive impact. Despite all this, there still are problems. The purpose of this paper is to discuss some of these problems.

Generally, the source of the problem is inadequate communication, — not always, but most of the time. Some problems are caused by failure to communicate sufficient information on expected plant upsets to the original equipment builder, or to take this information into account while performing the plant design. On the other hand, some problems are caused by the original equipment builder but have not been reported properly by some type of feedback. Without proper

feedback, the manufacturer is unable to “correct the error of his ways.”

As a review and to establish a base from which to communicate, refer to Figures 1, 2, and 3. These are block diagrams of lube or lube and seal systems of varying complexity, depending on the service in which they are used. Figure 4 shows a photograph of a large lube oil console. In common, they all include a source, consisting of multiple pumps, coolers, and filters. To keep the illustration simple, not all controls or control variations are shown. At first glance it would appear difficult that even in its basic form, such a simple string of equipment could be the source of problems.

PROBLEMS

The first problem to be discussed has a rather obvious solution, or does it? The point in question is the power source to drive the pumps. A positive pressure must be provided to insure a flow of oil to the bearing and some type of seals. This function is adequately provided by a pump, if the pump driver has power. Normally two independent sources of power are provided, such as steam for a steam turbine driven main pump and an alternating current electric pump stand-by (Figure 5). Unfortunately, as reliable as this scheme is, all is not always well. Using instances from one of the largest and one of the smallest operating divisions, there have occurred over the years several damaging failures due to a power outage. Partly, this problem occurs because back at the source electricity and

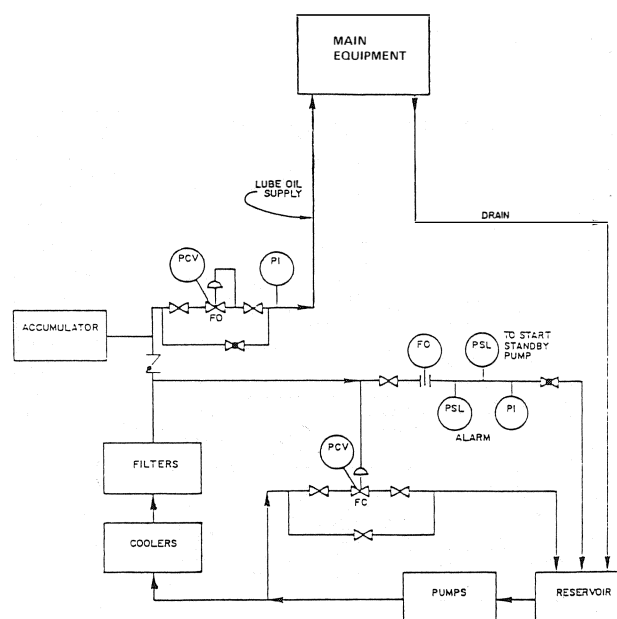

Figure 1. Lube Oil System.

steam are not necessarily truly independent of each other. Therefore, on a full outage of electric power, there is a good possibility that the steam is not far behind. The first solution after a full power outage was to retrofit many of the critical equipment units with a third pump sized to provide oil to the bearings during coastdown. Various forms of independent power from DC to air have been used with a reasonable degree of success. Figure 6 shows a DC driven coastdown pump. For the large horsepower trains where the lube and seal system pumps are of a larger size, a different approach has been used.

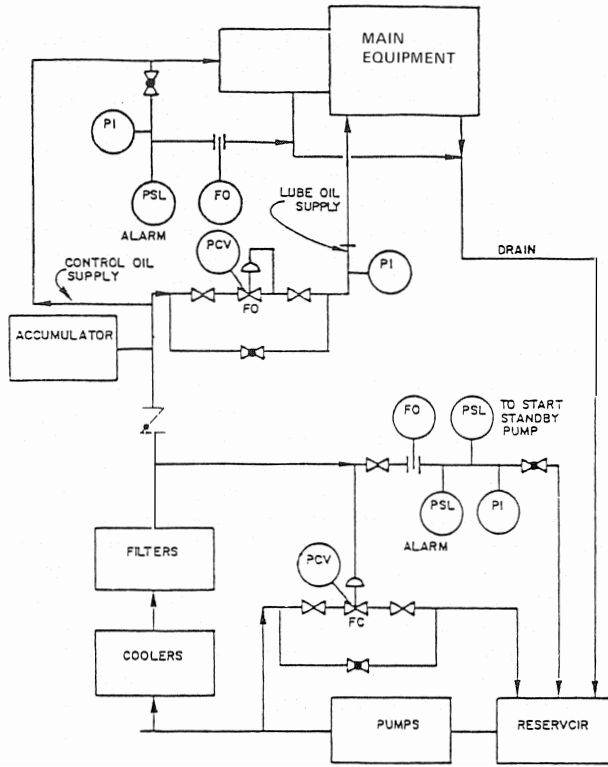

Figure 2. Lube and Control Oil System.

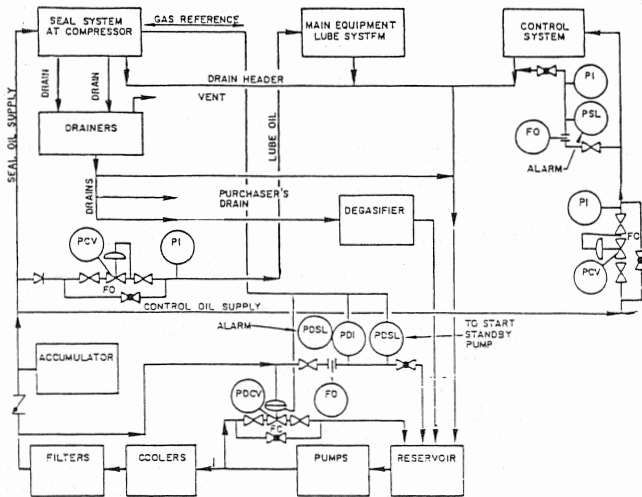

Figure 3. Combined Lube, Seal and Control Oil System for Contact Seals (No Overhead Tank).

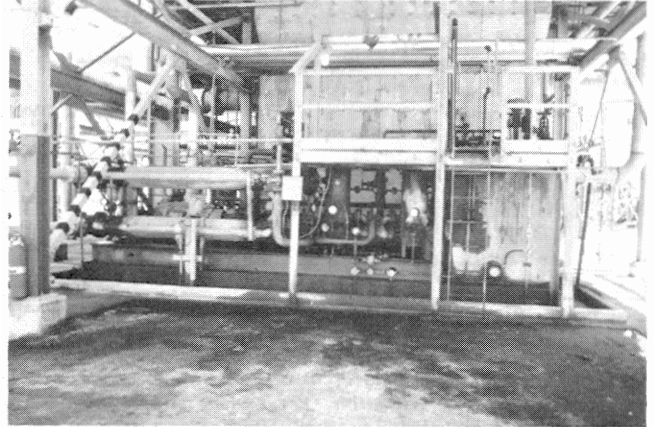

Figure 4. A Large Lube, Seal and Control Oil System.

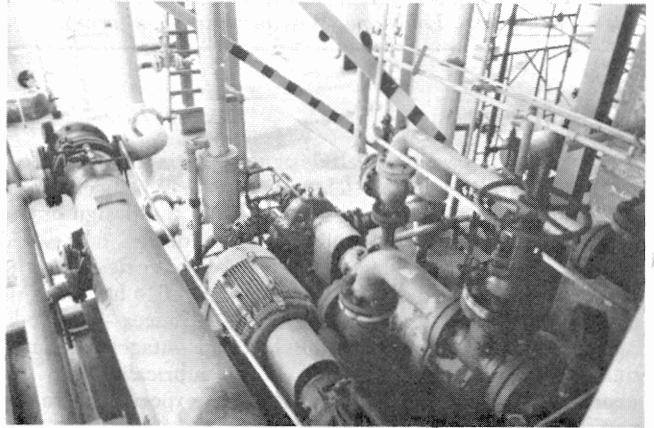

Figure 5. Steam Turbine Driven Main and Electric Motor Driven Auxiliary Pumps.

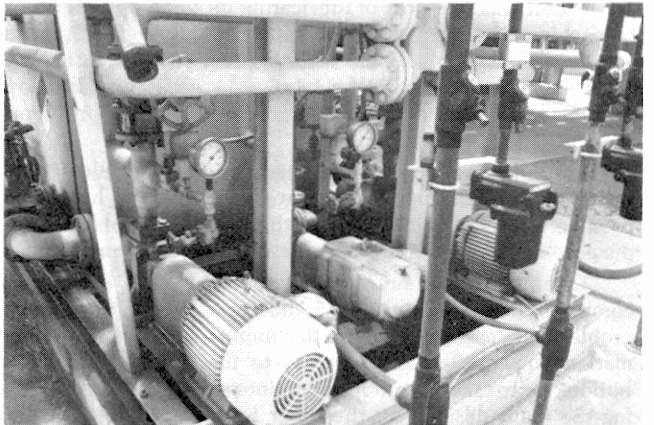

Figure 6. DC Motor Driven Coastdown Pump.

A vertical steam driven direct coupled pump was added to the system. Figure 7 shows such a pump. The steam turbine is a large clearance unit capable of operating on lower than normal steam. As the steam system decays, so does the output of the pump. The machinery train has slowed down to a point where less oil is required and the two pair rather nicely. This system works reasonably well on a large train and large steam system with a relatively large inherent storage capacity. This system did not function well at one of the smaller operating units where, when the systems went down, they were really down. Here another solution was used. A quite reliable source of pressure is gravity. By the addition of an overhead tank floating on the system, a rundown source of oil has been provided without any other outside power. Figure 8 shows an overhead lube oil coastdown tank. To avoid the use of a pressure vessel, the system piping as shown in Figure 9 is used. There are many alternatives to this. In fact, several different ones are used in the author's organization, but the one in the illustration appears to meet the need in most locations. The one primary requirement for this system is that the tank static head set by the elevation be less than the low oil pressure trip. This is necessary in order to use the entire contents of the tank after the unit has tripped for the coastdown. The size of the overhead tank is always a problem in that the time factor for coastdown is not exactly known nor is there an exact value established for quantity of oil to the bearings. Experience would indicate that the first minute is critical. Time and quantity become less critical thereafter because of the rate of deceleration of the turbomachine. A rule of thumb that works is to size for five minutes using the following relationship for quantity:

$$Q_t = \sqrt{\frac{P_t}{P_n}} \times (Q_n)$$

Q_t = Flow at trip GPM

Q_n = Flow to bearings at normal pump pressure

P_t = Oil pressure at trip PSIG

P_n = Normal oil pressure at the header PSIG

In actual experience, a value as small as three minutes has been used, as well as larger than five minutes.

In passing, an accumulator at ground level may be substituted for the coastdown tank, but it must have either a trapped gas bladder or a gas supply. It is not quite as reliable as gravity.

Another problem that has been experienced, that seems to fall into the area not covered by normal specifications and falls into interdiscipline areas in design, is the problem of electric pump startup. If it were not so serious, at best it would be quite embarrassing to have the standby pump start switch close and the electric pump not start. There have been a number of these type problems due to the following causes:

1. Driver sized too small for startup oil temperature.
2. Seal system stagnation pressure higher than allowed for in driver sizing.
3. WR^2 of the pump and motor neglected.
4. Voltage lower at terminals than motor sized for.

These four items, any or all in combination have caused problems. These conditions would not have occurred had there been communication between design people, both as manufacturer and between plant design mechanical and electrical disciplines. There is very little else one can say after pointing out the problem, as the solution at design time is relatively straight forward. At startup time or at the first need to transfer to the

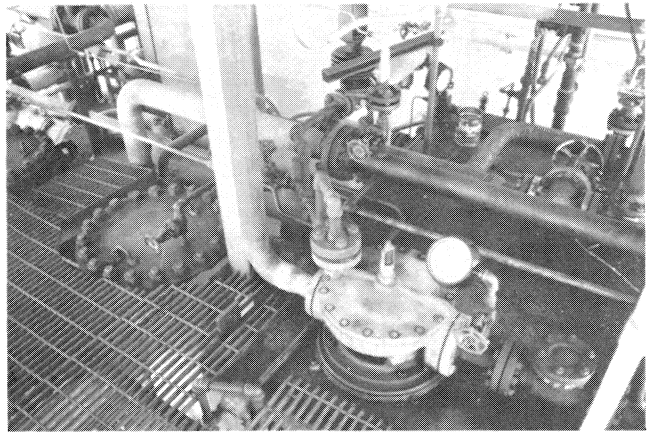

Figure 7. Steam Turbine Driven Coastdown Pump.

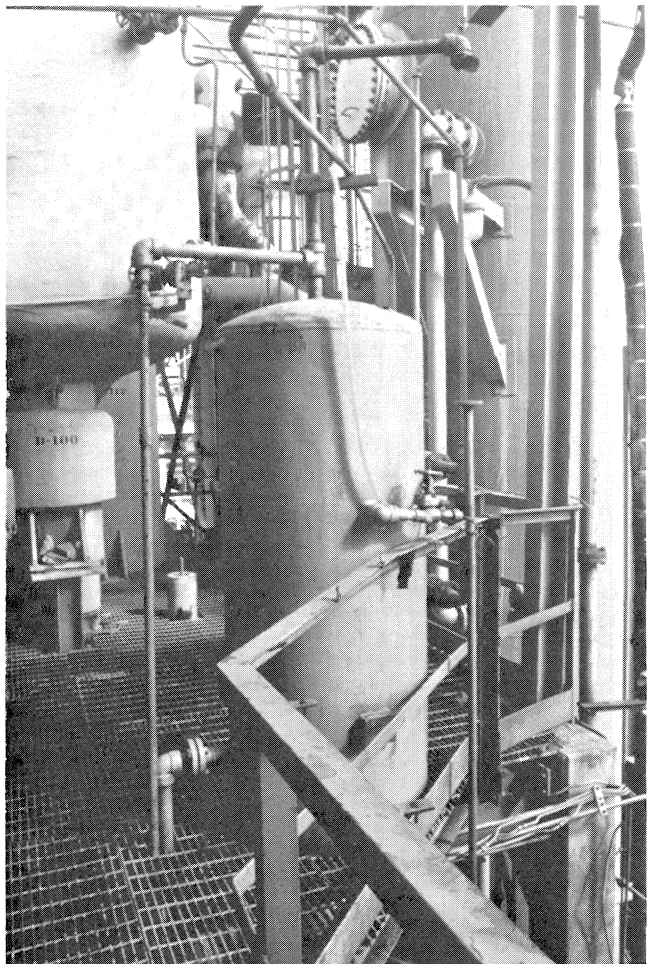

Figure 8. Overhead Lube Oil Coastdown Tank.

standby pump, the solutions are not all that easy. Probably the most unusual one mentioned bears one more comment, this being the third item, WR^2 . Normally this is not a factor. However, in conjunction with low voltage, a large system, or in the rare case where a gear might be used, it merits consideration in the system design.

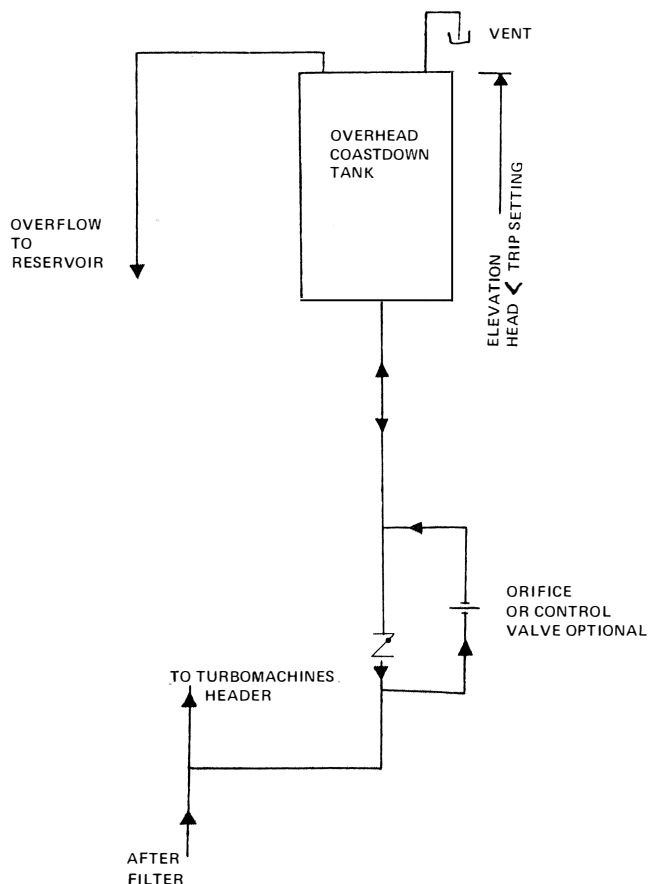

Figure 9. Overhead Coastdown Tank Piping.

Another problem was caused by one of several causes. The problem was the collapsing of filter elements. The time at which the filter elements collapsed was traced to that period of time during which both pumps were running. Further investigation showed that the bypass control valve was not as shown in Figure 1, but was located downstream of the filters. There are many pros and cons regarding this practice. The purpose of mentioning this particular failure is to point out the problem. The solution in the existing unit was to move the control valve to the position indicated in Figure 1. However, had the filters been checked for pressure drop with two pumps running, the initial position of the control valve would have been adequate.

On at least two occasions there have been what at first appeared to be mysterious pump failures. The pump was a screw type pump and generally considered very reliable. A detailed investigation revealed that when the combination of two pumps running, or high system pressure occurred at the same time, and the oil temperature in the tank was at a maximum, the pumps would fail. Immediately, the location of a control valve before or after a cooler becomes a factor regarding reservoir temperature. Again on larger systems, oil heating in the pump is a real factor in design. The pump manufacturer's literature indicated a possible minimum viscosity problem when the circumstances were considered together. The pump manufacturer was somewhat reluctant to admit the choice was marginal in that he sold to original equipment manufacturer's (OEM's) more than users and that in most cases the OEM chose the pump. This he felt put him in a compromising position regarding the choice. By and large the facts came out that the pump chosen was the best the OEM felt he could make to

meet conditions. Further investigation revealed that for extra money a pump of generally similar construction, but designed for low viscosity, high pressure service, was available. Because of its cost it was normally not offered for lube oil service. Communication could have easily prevented this problem. While the cost of the pump itself was substantial as a pump, it was negligible in the total equipment train. The economics of making the discovery far outweighed paying extra for a more rugged pump.

One minor problem has occurred and is mentioned in passing more as a flag than a specific problem and solution. The problems encountered and the solutions thereto have not, in the author's opinion, been technically as sound as possible. The problem is one of control stability. When a system such as Figure 3 is commissioned, it consists of many control loops which may interact. Direct operated controllers are usually preferred for simplicity. Reliability, while it should go together with simplicity, is more elusive. Manufacturers usually offer direct operated controllers to be competitive, not reliable. The inherent intelligence of a direct operated controller is limited. Some problems have been solved using small accumulators to provide capacitance. Another solution is a more sophisticated controller such as a pneumatic or electronic multimode controller working into a valve positioner. A more comprehensive analysis at the time of design would probably save startup time and provide reliability.

ENERGY

At this time when everyone is trying to adjust their thinking to escalating energy costs, a few words regarding energy related trade-offs seem in order. For this only a bit of philosophy can be offered. When discussing problems, the problem of undersized motors was mentioned. Because of problems with starting motors quickly in standby service, there is a tendency to oversize motors. The oversizing must be weighed against the poor part-load efficiency of motors. As systems increase in size and energy costs go up, the utility cost of the lube and seal system must be a factor in design. Consideration must be given to the selection of an efficient driver regardless of type.

A scheme that can save pumping power on a refrigeration unit's combined lube and seal system is shown in Figure 10. The refrigeration unit seals normally run at relatively low pressure during operation and require high pressure at shutdown and startup. The controls in Figure 10 permit the pressure to pick up only when needed. The driver must be sized for the higher pressure, but if a careful selection for part load efficiency is made, energy can be saved. Figure 11 shows an overhead seal differential pressure tank. Such a tank is referenced to the compressor suction. It is used to maintain a constant differential seal oil pressure just above the suction pressure under all conditions of operation and shutdown.

COMMERCIAL

Some vendors provide lube oil systems ranging from a complete adherence to API 614 requirements to several levels of compromises and corresponding cost savings. For instance, the complete API 614 system would include stainless steel pipe downstream of filters, turbine driven main and electric motor driven auxiliary pumps, a reservoir with eight minute retention time, and a complete performance test. To compare costs, a base cost factor of 100 percent will be assigned to this system. The next level of compromise would replace the stainless steel piping with carbon steel, eliminate the performance test and reduce the reservoir retention time to five minutes. The cost factor for such a system would be about 75 percent. The next

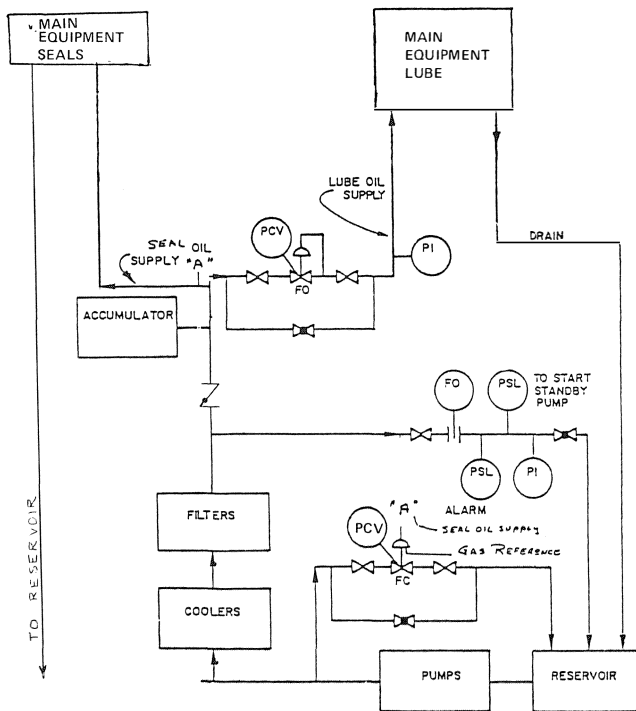

Figure 10. Combined Lube and Seal Oil System for a Refrigeration Compressor.



Figure 11. Overhead Seal Differential Pressure Tank.

level of compromise would further reduce the reservoir retention time to three minutes and replace the steam turbine driven main pump with a shaft driven main pump. The cost factor for this system would be about 50 percent. This comparison is included here for the sake of completeness and to serve as a guide for decision making.

In giving the comparison of cost there is a strong tendency to come back and justify the full API 614 system. For critical equipment where outages are catastrophic, the best approach is to do just that, use the full system. If, due to economic reasons compromises must be made, the above presented costs are roughly in sequence relative to degree of compromise. As an example, the test in the shop is really insurance. Those items determined in the shop can certainly be done later in the field and if there are no major problems, the money savings become real. The same general rationale can be applied to the stainless pipe, however, most startup engineers would argue that the extra cost for the stainless pipe can be justified by the reduced flushing time required before startup.

From the preceding it is shown that each step in cost savings involves a trade-off of reliability or serviceability and economics. These decisions can only be made on an individual basis.

One last area when lube and seal systems present problems is somewhat of a commercial problem. There is a tendency for the OEM to look at profit and loss on lube systems. The free enterprise system encourages competition and the right to a profit. Unfortunately, the ultimate user frequently loses out and if given a choice of where to place the cost, would prefer the charge "up front," not after delivery. What this is trying to say is that "farmed out" lube systems have, in the author's experience, been more of a problem than those built by the OEM. Problems range from coordination, component selection, and shipping damage. It would appear a lube system built by the OEM is monitored as if it really were part of the package. The outside built units are treated as any "buy out" item and lose the concept of reliability. To the user, given the choice of pay now or later, it would be wise to consider the "now."

CONCLUSION

A number of problem areas have been presented with some of the solutions that have proven satisfactory. The important factors to consider are that lube and seal systems are still as critical as ever. Lube and seal systems, while they have come a long way in the past several years, deserve continued development — that problems can and still do occur. Finally, one of the best overall approaches is good communication between manufacturer and user, and within the user's own organization.

REFERENCES

1. Clapp, A. M., "Fundamentals of Lubrication Relating to Operation and Maintenance of Turbomachinery," Proceedings of the First Turbomachinery Symposium, Texas A&M University, 1972, p. 67.
2. D'Innocenzo, M., "Oil Systems — Design for Reliability," Proceedings of the First Turbomachinery Symposium, Texas A&M University, 1972, p. 163.
3. API 614, "Lubrication, Shaft-Sealing and Control Oil Systems for Special Purpose Applications," American Petroleum Institute, 1973.

