

RETROFIT INSTALLATION OF A BOILER FEED PUMP HYDRAULIC COUPLING

by

Merwin W. Jones

Systems Engineer

Scott R. Taylor

Engineer, Generating Engineering Department

Potomac Electric Power Company

Washington, D.C.

and

Bernard S. Herbage

President and Technical Director

Centritech Corporation

Houston, Texas



Merwin W. Jones is the Systems Engineer for the Thermal and Mechanical Systems Engineering Group for the Potomac Electric Power Company located in Washington, D.C. As Systems Engineer, he is responsible for directing the engineering for any new construction or modifications to existing equipment within the energy conversion area of the company's power plants. A graduate of the Virginia Polytechnic Institute and

State University, he holds a B.S. degree in Mechanical Engineering.

During almost 15 years at PEPCO, he has been involved with modification or replacement of most equipment in the condensate, extraction, feedwater, cooling water, and turbine systems. He has authored papers for the Electric Power Research Institute and was a member of the ASME's Power Test Code Committee for rotary pumps. Mr. Jones is a member of the Turbomachinery Symposium Advisory Committee and ASME.

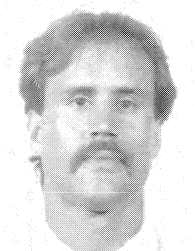

Scott R. Taylor received his B.S. degree in Mechanical Engineering from Bucknell University in 1981. After graduation, he joined Potomac Electric Power Company, where he initially worked in the Construction and Project Management Sections of the Generating Engineering Department. He now works in the Thermal/Mechanical Section where he is responsible for the selection of new equipment and applications engineering,

involving feedwater heaters, condensers and rotating equipment. Additionally, he is responsible for the gas turbine and combined cycle conceptual engineering of a proposed gasification-combined cycle power plant. He is currently studying for a Masters' in Business Administration degree.



Bernard S. Herbage is Technical Director of Centritech Corporation. Centritech Corporation, founded in 1971, specializes in the design and manufacture of fluid film bearings and seals to solve end-users problems, often requiring Centritech's in-house rotordynamic analysis capability.

The first ten years of Mr. Herbage's career were spent with Allis-Chalmers, in the Mechanical Design Sections of the

Steam Turbine and Generator Departments, specializing in unit sizes through 1000 MW, and on the design, application, and testing of high capacity thrust and journal bearings.

The Allis-Chalmers experience prompted his move to Waukesha Bearings Corporation, where he served as Chief Engineer.

For the past 32 years, Mr. Herbage has worked with virtually every major high speed rotating machinery manufacturer in the design and application of fluid film thrust and journal bearings. A number of his innovations are now part of many OEM bearing designs.

Mr. Herbage is a registered professional engineer, with a B.S. degree in Mechanical Engineering from Bradley University, and was a member of Tau Sigma.

ABSTRACT

The application of main turbine-generator shaft drive for boiler feed pumps is generally accepted as a method to increase unit efficiency. The use of shaft drive eliminates the power requirement of an auxiliary motor or turbine drives. The addition of variable speed to this shaft drive provides economic advantages at lower unit loads. During the installation of any equipment, it is necessary to pay particular attention to all facets of the design. It is especially important when dealing with an operating facility for which many design details are not readily available. A case history of a utility's experience in installing variable speed hydraulic couplings for main boiler feed pump drive service is presented.

INTRODUCTION

The Dickerson Generating Station is a three unit plant owned and operated by Potomac Electric Power Company. The plant's units began service between 1959 and 1962. At the time of their construction, these units were among the most efficient in design. In its first year of operation, Unit 1 was rated as the world's best.

The basic cycle is a regenerative reheat system with initial conditions of 2400 psig, 1000°F main steam and a reheat to 1000°F degrees. The cycle has seven extraction feedwater heaters and uses a cross-compound turbine-generator as shown in Figure 1. The turbine is separated into two parallel turbines, each with its own generator. The first turbine is a combined double flow high pressure/intermediate pressure shaft, which turns at 3600 cpm. The second turbine is a single flow low pressure shaft which turns at 1800 cpm. The two units have no mechanical tie to maintain the speeds, but instead, are electrically connected through the generators. The combined output of the two turbines is nominally 185 MW for a plant total output of 555 MW.

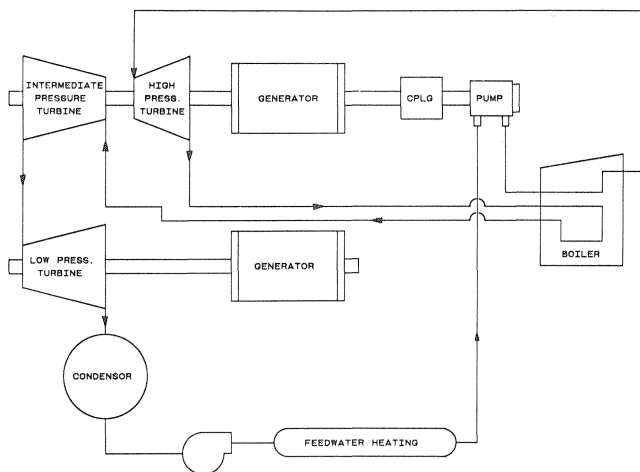

Figure 1. Simplified Flow Diagram.

The main boiler feed pump is connected to the outboard (collector) end of the high pressure/intermediate pressure (H.P./I.P.) turbine-generator via a variable speed coupling. The original variable speed coupling used for this application was an electromagnetic coupling which was selected for its high efficiency and low slip. This coupling was directly coupled to the generator shaft. Each unit also has a high speed (7200 cpm) auxiliary boiler feed pump and turbine driver to provide for easier startup and to supply feedwater when the main pump is out of service.

HISTORY

The variable speed couplings installed on the three units were given careful consideration during the design of the plant. The electromagnetic couplings had the advantage of being more efficient and potentially easier to control. These particular couplings were considered to be somewhat of a development project by some, but the manufacturer had built ones which were higher speed and others which were higher output. Although none of the combined speed and power had been built, it seemed that the manufacturer had the ability to build such couplings. At a generator speed of 3600 cpm, the couplings were designed to transmit 6350 hp with a torque of 10500 ft-lb at 2.08 percent slip (3525 cpm).

The couplings did perform as efficiently as expected and were still quite efficient at the time of their replacement. They did, however, suffer from poor reliability. Some of the problems encountered appear in retrospect to be related to the extrapolation of size and speed.

The design of these couplings relied on the torque developed by the interaction of two rotating fields, a primary magnetic field (the drum) and a secondary magnetically induced field (the rotor). The rotor is contained inside the drum, with its shaft protruding through one end via pilot bearings. The drum also has a shaft (opposite end); it protrudes through the casing via journal bearings. The primary field is produced by a surrounding stationary field which is excited by a direct current energized coil. The secondary field is produced by eddy currents, caused by the slip between the rotor and rotating inductor drum. Slip losses result in heating of an oil which is cooled externally.

Initially, the input shaft was connected to the coupling drum and the pilot bearings were of a babbitted design. When first placed in service the coupling displayed high vibration of 4 mils to 8 mils, which resulted in failure of the pilot bearings. A redesign switched the input and output ends and replaced the pilot bearings with roller bearings. These efforts reduced the vibration to a tolerable level. Numerous other problems involving overheating also occurred, thereby resulting in further design changes. These changes included:

- Modification of the internal oil cooling circuit.
- Installation of a larger external oil cooler.
- Installation of an improved oil feed to the pilot bearings.

All of these changes did not result in a reliable coupling. An evaluation, made by both the manufacturer's and the owner's engineers, concluded that two major problems still existed. The first of these was that the oil used for cooling and lubrication was flashing in the close clearances between the rotating drum and the rotor. Vibration was caused by the flashing, much in the manner in which a pump experiences cavitation. The second problem was that the pilot bearing was not designed for the high loads and high speeds encountered during startup when the maximum slip of 3600 cpm occurred. In fact, no manufacturer of roller bearings could supply a bearing to carry both the high load and the high slip, simultaneously.

A contributing factor in the failures also may have been that the coupling was rigidly connected to the generator shaft. During startup, the generator/coupling operated with a parallel offset on seven mils to eleven mils (0.007 in to 0.011 in). This increased the loads on the pilot bearing.

After 22 years of operation, the cumulative effects of vibration and thermal cycling (plus the associated bearing, drum and rotor rebuilds) had taken their toll on the coupling life expectancy and unit availability. Since the couplings were aging and were the only ones of their size ever manufactured, the purchase of replacement parts required long lead times. Fortunately, the turbine-driven auxiliary boiler feed pump could be used to supply feedwater, but only at the price of lower unit efficiency (approximately 40 Btu/kWh heat rate increase).

The poor reliability of the couplings, together with changes in electric demand which increased the number of startups, resulted in a study to determine the most economic alternative to provide reliable service.

The study examined a number of options to provide reliable service. These options were weighed against the poor reliability and the low estimates of remaining life of several major components in the electromagnetic couplings. The options examined included constant speed electric motors, variable speed motors, fluid drive hydraulic couplings and a cursory review of a variable speed steam turbine.

The method of comparison was based on establishing a system design for each option and then pricing the cost of installing

each. In addition, the operating costs over the life of the plant were estimated and used in the final evaluation. Since the options were so different, it is not reasonable to use these costs as a guide in selecting equipment for different applications. For example, the constant speed motor option required a significant modification to the pump recirculation system, which would not be required in the other options, and as a result of the recirculation rate had a very high penalty for energy usage. Assessing such a penalty is strongly influenced by the load curve at which the unit operates and should be calculated for each application.

The costs of the various options are illustrated in Figure 2. This chart compares the costs of each option to the average cost of all options. This chart shows only the capital cost of the installation without engineering and corporate overheads. The evaluated costs of the different options, when energy costs are included, are shown in Figure 3. Some points of interest are the fact that the constant and variable speed motors were so close in evaluated cost, and the fact that the steam turbine evaluated cost was so high. The primary reason for the steam turbine high cost was that a significant amount of piping, both steam and feedwater, would need to be rerouted and a new foundation installed. The hydraulic coupling could use existing foundations, fit in the existing location, and would require no modifications to the boiler feed pump or piping.

Replacement of the electromagnetic couplings with hydraulic couplings was especially attractive. Hydraulic couplings are widely used in the industry and have proved to be reliable. Based on this experience, the study determined that hydraulic coupling maintenance would equal one-tenth that of the electromagnetic couplings. Economic evaluation of the aforementioned options demonstrated that capital and evaluated costs would be lowest if the electromagnetic couplings were replaced with hydraulic couplings. Although the difference in cost between maintaining the electromagnetic couplings and replacement with hydraulic couplings was not substantial, the persuading factor was the belief that the reliability of the electromagnetic couplings would always be in doubt.

HYDRAULIC COUPLING DESIGN

Similar to the electromagnetic coupling, the variable speed hydraulic coupling transmits the torque of the prime mover (the H.P./I.P. turbine-generator) to the main boiler feed pump. As shown in Figure 4, the same oil is used for working oil (power transmitting oil) and for bearing (lube) oil. A main oil pump

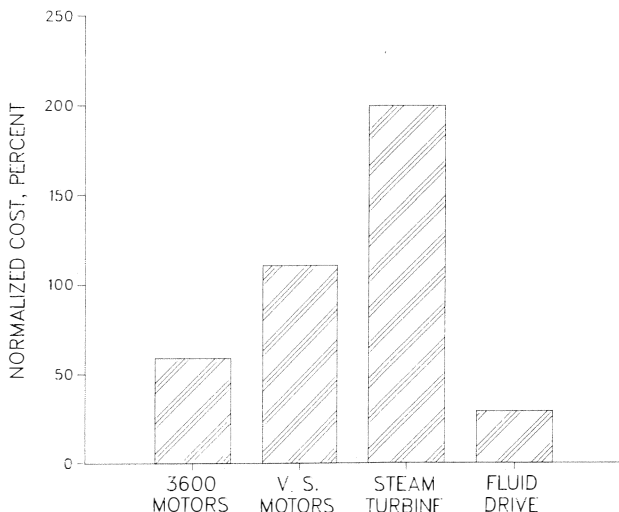

Figure 2. Installed Cost Comparison of Replacement Options.

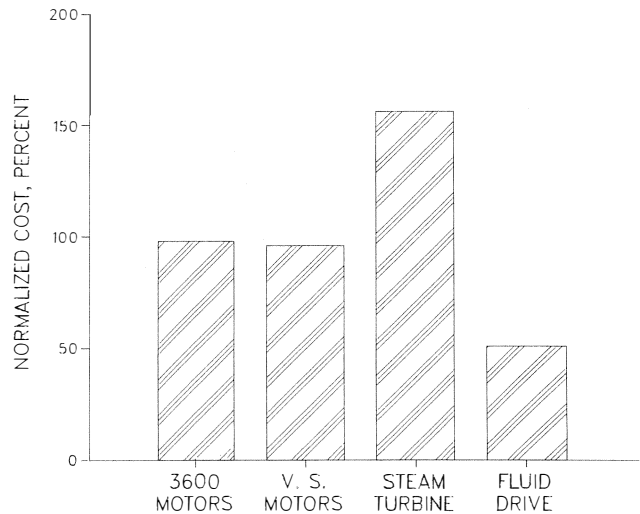

Figure 3. Evaluated Cost Comparison of Replacement Options.

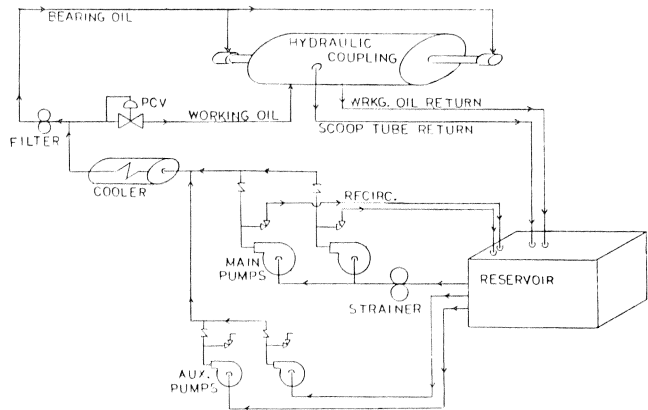

Figure 4. Hydraulic Coupling Oil Circuit Flow Diagram.

draws oil from an external reservoir through a duplex strainer, then passes it through an oil cooler. After the cooler, a portion of this oil passes through a filter then on to the bearings, while the rest of the oil is directed through a pressure control valve. After the valve, this working oil is passed through an orifice plate into the working chamber of the coupling primary wheel (impeller).

The torque of the turbine-generator accelerates the impeller and the oil in the working chamber. The chamber of the impeller encloses a secondary wheel (runner). An oil ring is formed in the working chamber due to centrifugal forces. Due to shear forces, the oil ring transmits torque to the secondary (output) shaft. A pressure drop occurs between the primary and secondary wheels; essentially, a slip is required for power transmission.

The thickness of the oil ring (i.e., the amount of filling in the working chamber) determines the degree of power transmission and is controlled by a scoop tube. When this scoop tube moves into the chamber, oil is removed by the scoop tube from the oil ring and the ring thickness decreases, slip increases, less power is transmitted, and output speed decreases. When the scoop tube moves away from the chamber, less oil is removed and the oil ring thickness increases, slip decreases, more power is transmitted, and output speed increases.

The thickness of the oil ring can be varied anytime during operation. This makes the transmitting capacity of the coupling adjustable and permits stepless speed regulation of the boiler feed pump. The oil removed by the scoop tube travels back to

the external oil reservoir by pressure head. The oil coolers dissipate the heat created by the coupling slip.

A disc brake is mounted on the output end of the coupling. The purpose of the brake is to secure the output shaft so that maintenance can be performed on the main boiler feed pump while the turbine-generator is in service. Thus, the brake was designed to offset twice the windage torque created by the turbine-generator shaft rotating at 3600 cpm (approximately 1100 ft-lb).

DESIGN PROBLEMS

As a first step in replacement of the electromagnetic couplings, a comprehensive technical specification was created so as to enable bid invitation for hydraulic couplings. This specification not only covered the basic requirements for the couplings themselves, but also for auxiliaries (oil coolers, main oil pumps, lube oil pumps, and pump electric motors). Subsequent performance evaluation of the existing auxiliaries indicated that replacement would be prudent considering their age. Further, the available capacity of the plant closed cooling water system was examined to confirm its ability to maintain proper oil temperature for the hydraulic couplings.

Stringent requirements were specified for the hydraulic couplings to ensure their future reliability. To match the unit feedwater requirements, the couplings would have to transmit turbine-generator torque with slips not exceeding 2.2 percent. Physical dimensions of the couplings would have to be compatible with the available shaft separation, shaft heights and the existing turbine deck coupling soleplates. The couplings would have to accommodate generator and feed pump shaft offsets during startup. First critical speed and maximum vibration levels for the couplings were specified. Finally, criteria was set for the couplings' radial and thrust bearings, output shaft brakes, and protective devices.

After a manufacturer was selected and as the details of the equipment were received, several problems were noticed. First, the new couplings were substantially shorter than the ones being replaced. Consequently, the flexible connection couplings grew in length to a point where concern arose regarding the use of diaphragm type couplings (as were specified). This was resolved by reverting to a gear type coupling which could be procured without delaying the upcoming outage. One other small problem was fitting the new couplings on the existing soleplates of the electromagnetic couplings. The existing soleplates were used because of a reluctance to install new anchor bolts in a concrete turbine deck containing massive amounts of large diameter rebar. This problem proved to be more of a drafting effort, but could only be done when each of the existing couplings was out of service for maintenance.

A further problem occurred when the coupling manufacturer submitted his operating recommendations in the form of logic diagrams. It appeared that the method used to protect the coupling during any upset condition, such as low lubricating oil pressure, was to trip the turbine. Although loss of oil pressure is significant, the means to deal with the problem was of particular concern, especially in view of the fact that the turbine requires more than 30 minutes to coast down to turning gear speed. Severe damage to the coupling could still result even if the turbine was tripped. As a result of numerous discussions with the manufacturer's staff, many changes were made to the operating logic to reflect the normal practices of an electric utility. These discussions were somewhat more difficult than usual, since the couplings were of foreign manufacture. Specific changes which resulted were: a change from trip to runback status of the coupling; more attention given to alarms for the control room operators; more reliance given to the backup

systems, such as redundant main oil pumps and direct current (DC) emergency lube oil pumps. All operating principles were agreed to by both parties.

The final design problem was discovered when the drawings of the installation were sent to the turbine manufacturer for review and comment. During the review process, it was pointed out that other similar units which used an overhung extension of the generator shaft (for the field excitation collector and for driving the boiler feed pump) had experienced vibration problems when the driven equipment was disconnected from the generator shaft. This occurred because the driven equipment had been rigidly bolted to the generator shaft and thereby had restricted the vibration of the generator. This was particularly the case for lateral vibration, since the generator is supported on elliptical bearings. The vibration caused by uncoupling the rigid connection had been severe enough to result in flashover in the collector brushes. The proposed modification would probably be worse because the flexible connection coupling would not contribute any restraint to the generator shaft, but would add mass at the end of an overhung shaft. Since the turbine supplier had all appropriate data, an order was given to perform a dynamic analysis of the rotors.

GENERATOR/COLLECTOR SHAFT ANALYSIS

The analysis was performed using a somewhat typical computer model of the shaft and bearing system (Figures 5 and 6). At the utility's direction, the model was also tuned to match vibration data taken during a startup. This data identified two critical speeds which the generator passed through, one at 1000 cpm and a second at 2700 cpm. The orbit and sine wave data is shown in Figure 7. A waterfall plot of the shaft end during a startup is shown in Figure 8.

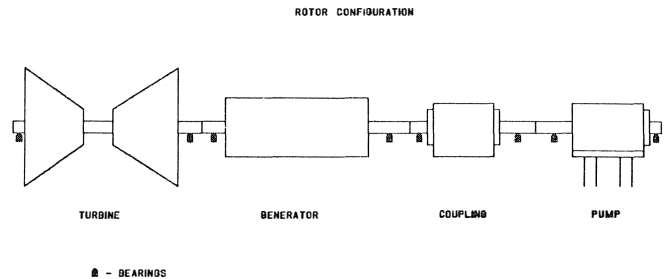

Figure 5. Generalized Rotor Arrangement.

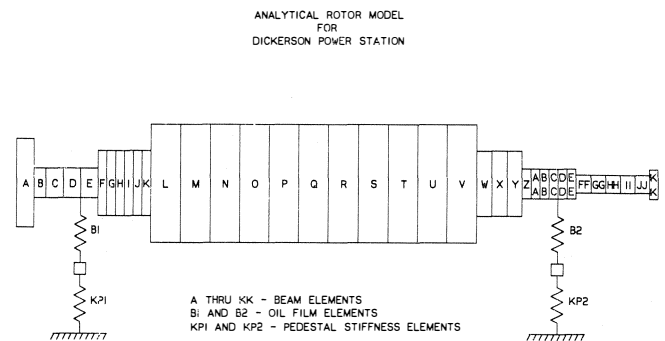

Figure 6. Generator Shaft Model.

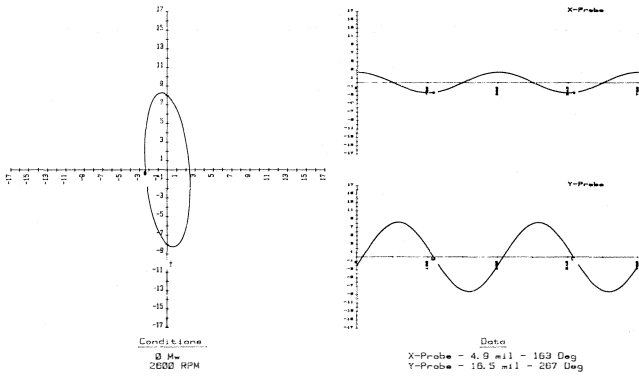

Figure 7. Orbit and Sine Wave Data for the Generator Shaft End, Uncoupled Condition.

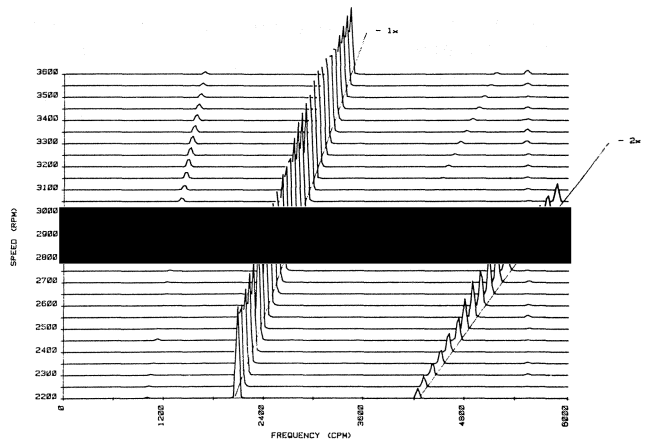

Figure 9. Undamped Critical Speed Map.

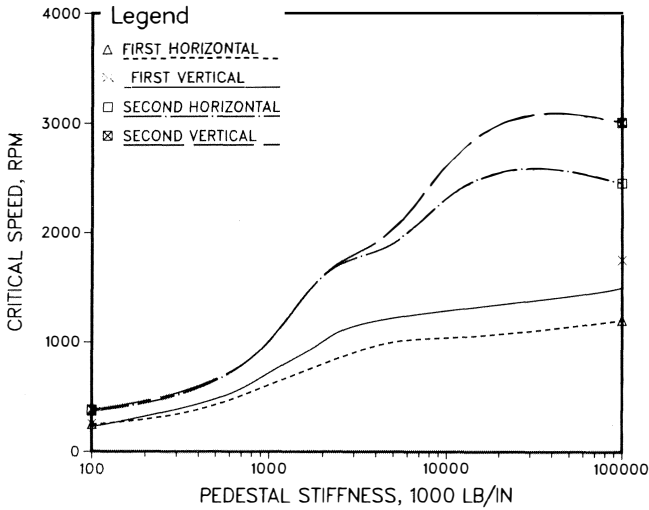

Figure 8. Waterfall Plot of Generator Shaft End During a Startup, Uncoupled Condition.

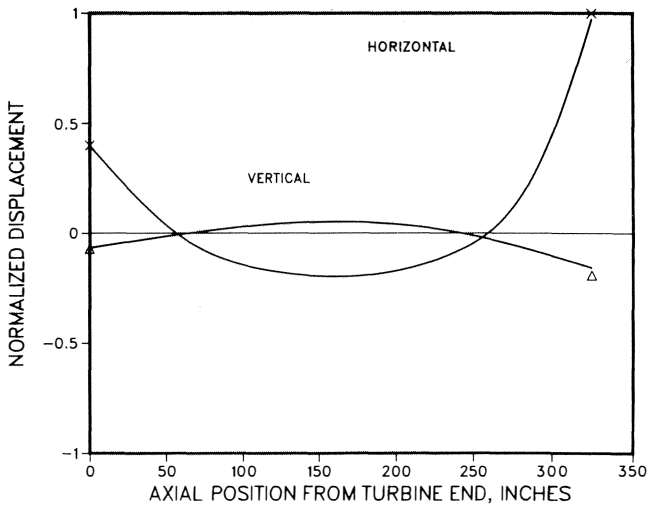

Figure 10. Undamped Mode Shape at 2579 cpm. (Note the high deflection at the shaft end.)

In order to calibrate the model to reflect actual data, an undamped critical speed map was made first (Figure 9). The critical speeds plotted were for the first and second vertical and horizontal modes. A pedestal stiffness was then chosen to correlate with the measured critical speeds. Although not exact, a value of three million lb/in was used as the best correlation between the measured values for the first and second critical. Mode shapes were also plotted as a means of identifying which modes could cause large amplitudes at the shaft end. One example of the mode shapes at 2579 cpm is shown in Figure 10. This example shows the high amplitude at the end of the generator shaft in the vertical direction. Similar modes exist at slightly different speeds in the horizontal direction. The mode shapes were also used to identify which critical speeds correspond to the measured data. For example, the undamped analysis indicates a second critical at approximately 1600 cpm. However, the mode shape indicates large displacements at the bearings. These frequencies are probably critically damped.

Once a model for the existing configuration was established, the model was modified to reflect the effect of a flexible coupling. The major effects of the modification were to reduce the third critical speed to near that of the operating speed and to create a greater response to any unbalance force. A graph of the response to an assumed unbalance of one inch-pound is shown in Figure 11. As can be seen from the diagram, the response is

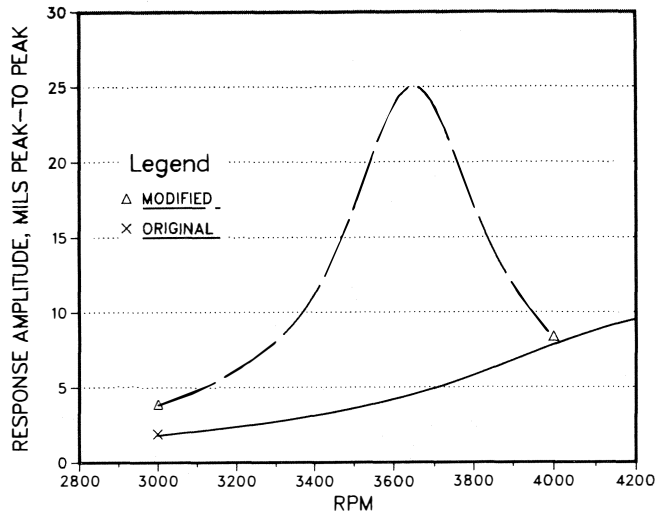

Figure 11. Predicted Unbalance Response of Generator Shaft.

approximately six times greater than the original at 3600 cpm. The critical speed now occurred near running speed, instead of several hundred cpm higher.

Because of the high risk of serious damage to the generator shaft due to vibration, an additional bearing for the shaft was considered. This presented some unique problems, but appeared to be the only way to reduce the vibration. An arrangement for such a bearing was suggested by the turbine manufacturer, but space considerations and the necessary modifications to the generator shaft were serious drawbacks to that design. An alternate designer of bearings was contacted to investigate the design of such a steady bearing and to provide a quotation for fabricating the bearing and pedestal.

STEADY BEARING DESIGN

The hydraulic coupling selected for use between the boiler feed pump and the main turbine generator/collector rotor was not designed to accommodate large axial movements nor was it designed to take large transverse loads whether static or dynamic.

Since the axial thermal expansion of the outboard end of the collector overhang has been measured to be over 5/8 in, a gear type flexible coupling was selected as the type to use for the mechanical link to the hydraulic coupling as shown on Figure 12.

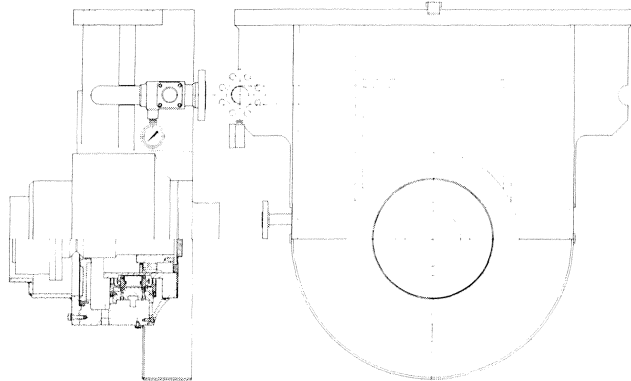

Figure 12. Steady Bearing Outline and Section.

The weight of the gear coupling added to the collector overhang required the use of a steady bearing. The logical location was selected as the gear coupling hub bolted to the generator shaft. The thermal rise and fall of the main generator bearing and of the steady bearing made the magnitude and direction of the load on the steady bearing unpredictable.

Under certain light load conditions, a fixed geometry journal bearing might become unstable and begin to whirl. Therefore, a tilting pad bearing with its inherently stable characteristics offered the best chance of success.

The exact size of the bearing was determined from a study of the maximum and minimum loads that might be imposed on the bearing. A calculation made of the stiffness of the collector overhang predicted a value of 500,000 pounds per inch. During operation, the expected rise of the outboard generator bearing was 0.018 in, while the expected rise of the steady bearing was 0.007 in. In a worst case scenario: should a preload of 0.014 in be imposed on the steady bearing, the maximum load on the bearing would be 7000 pounds. Because of the severe axial space limitations existing (16.5 in between shafts), as seen in Figures 13 and 14, a high capacity bearing design was used. With a bearing bore of 9 1/4 in, a 2.25 in pad length was selected to maintain a pad unit load of 336 psi. Typically, a load of 350 psi is recommended as a maximum, while loads of 500 psi or more

have operated successfully. The complete assembled bearing is shown in Figure 15, ready for clean up and shipping.

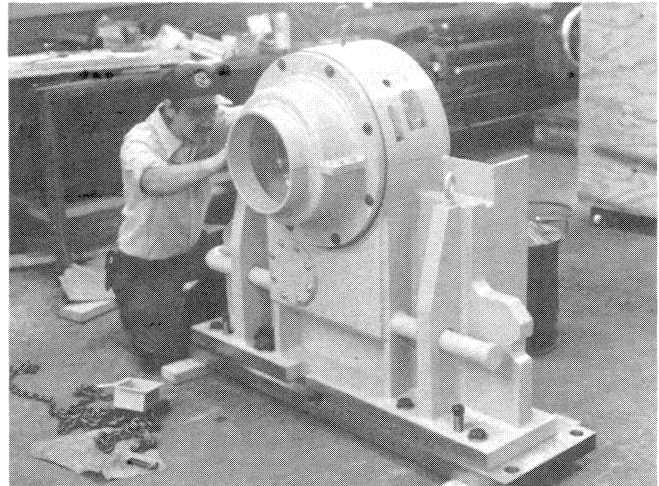

Figure 13. Steady Bearing, Assembled.

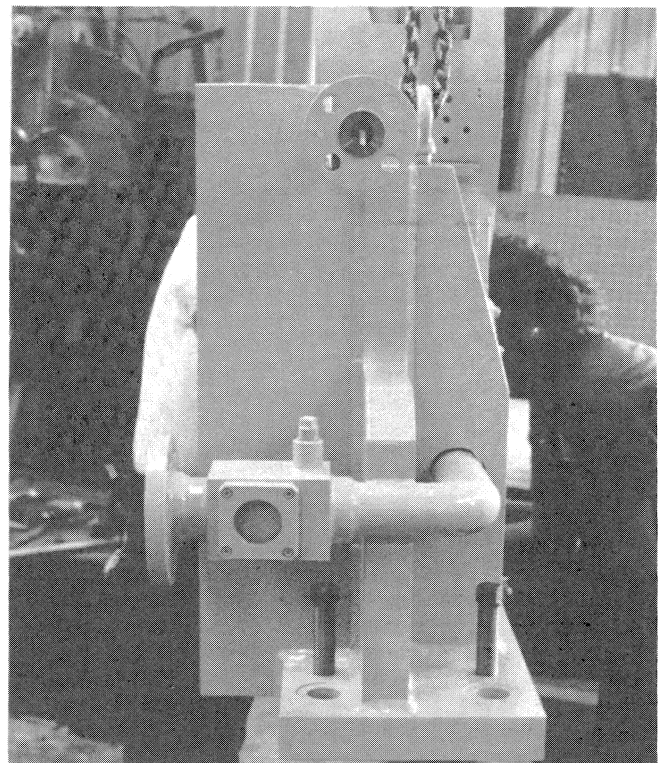

Figure 14. Side View of Steady Bearing.

Drawings and photographs of the tilt pad steady bearing and the support pedestal are featured in Figures 15, 16, 17, 18, and 19. Typically, in a situation such as this, it is prudent to provide the optimum bearing available to avoid potential problems of misalignment, high unbalance forces, fatigue failure, oil leakage, etc. Design features of this bearing include:

- A seven pad design was used to get a good length to width ratio of one. The seven pad design also can carry load in any direction with equal efficiency. Referring to Figure 15 and to Figure 16: pad orientation is load between pad, with a vertical down load.

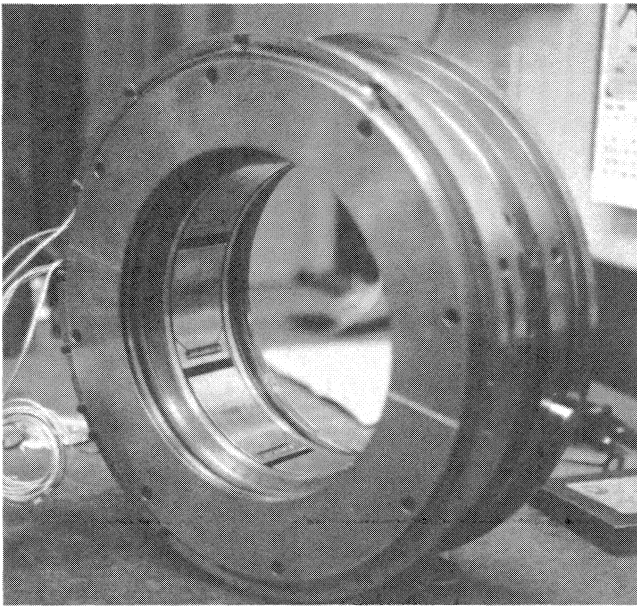

Figure 15. Tilting Pad Bearing.

- An offset pivot design is used for optimum load carrying ability. This feature, which assures positive preload action of the unloaded pads, is shown in Figure 16.

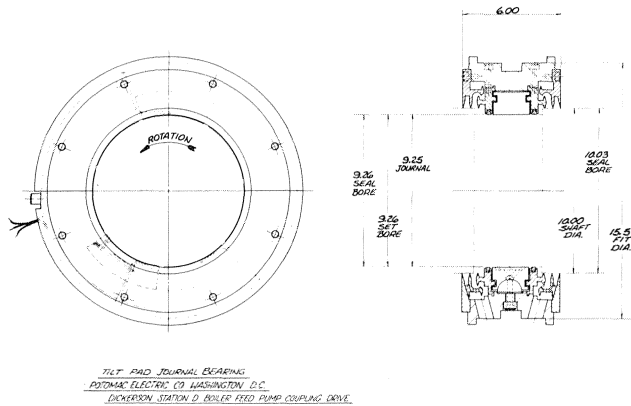

Figure 16. Tilting Pad Outline and Cross-Section.

- Journal pad pivots on ball supports (Figure 16) result in low pivot stresses helping maintain original running clearances even under severe operating conditions.

- Oil lubrication is to the leading edge of each pad through each spherical pad support. In addition to the grooves in Figure 17, a small amount of oil is circulated around the pad area.

- Thin babbitt (0.005 in to 0.007 in) centrifugally cast to the bearing bronze backing material was used as the journal pad material for greater load carrying ability and fatigue resistance. By looking closely in the groove area of Figure 17, this thin babbitt can be seen.

- To accommodate parallel offset misalignment between the generator shaft and the hydraulic coupling, the design included a gear type double mill spacer coupling, with the inner hub surface containing the coupling teeth, and the outer surface acting as the journal. The flexible coupling hub driving the floating spool piece shown in Figure 12 was extended and machined with a stepped recess to act as the journal surface. A number of seals at each end of the journal bearing act to control and restrict the flow of oil along the shaft to prevent oil carryover

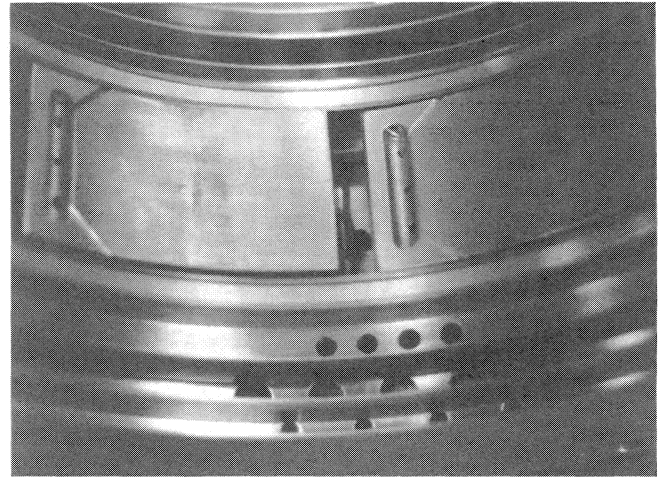

Figure 17. Oil Feed Grooves to Pads.

into the collector and toward the boiler feed pump end of the unit. The main control of the oil flow is through the journal pads themselves. Close clearance floating seals act adjacent to the pads, while several labyrinth seals acting on the larger diameter slingers direct the spent oil toward the bottom drains.

- A contoured seal between the steady bearing support and the collector (Figure 18) directs cooling air away from the shaft mounted fan through an opening in the pedestal base, which must also act as a duct leading to the basement. This ducting is a requirement that surfaced after the initial design was submitted for review. Sides of the ducting acted as stiffeners for the pedestal lower half, while a circular lagging fitted at assembly was provided for the upper half.

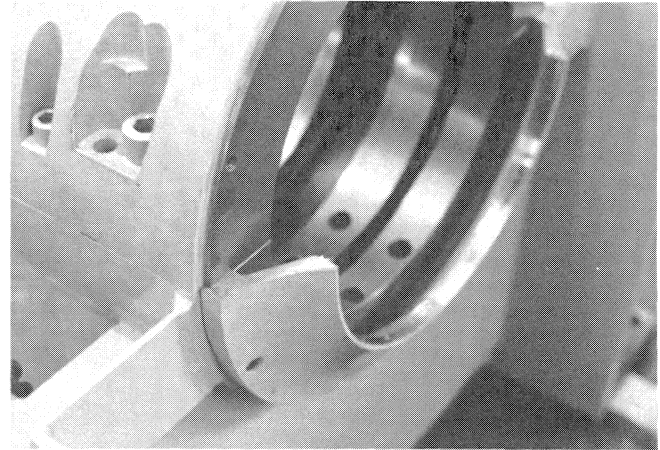

Figure 18. Bearing Housing and Seals.

- Electrical insulation is provided between the exciter overhang and the gear coupling hub to prevent stray currents from pitting the bearing or the gear teeth.

- Two bottom pads and one top journal pad with temperature probes were instrumented to monitor safe operation and to check the loading results of the unit alignment. In addition, proximity probes shown on Figure 19 were supplied to operate on the gear coupling hub just outboard of the journal bearing.

- Wishing to unify responsibility for design and manufacture, the company had one manufacturer supply the complete steady bearing unit including the soleplate, foundation bolts, hold down bolts, alignment shims, keys, coupling guard, and even the epoxy grout for field installation.

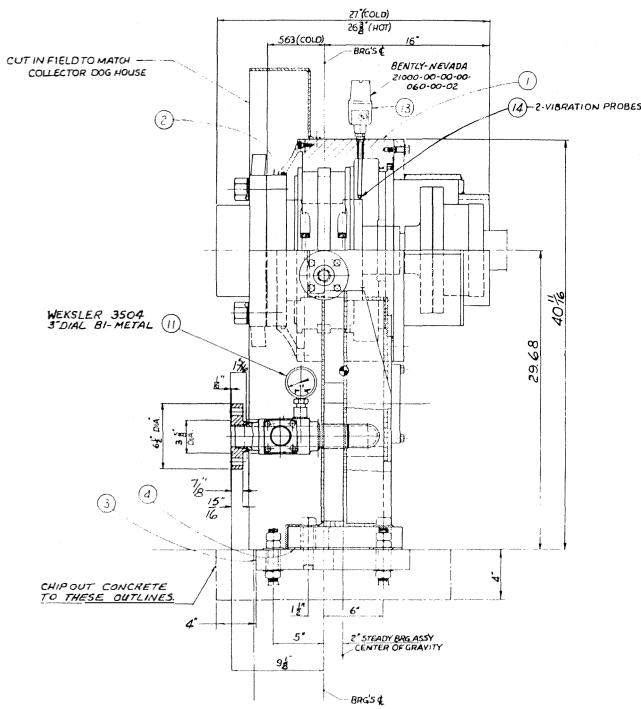

Figure 19. Final Outline—Side View.

- The coupling was designed with a shear neck to prevent any damage to the generator shaft, should a mechanical failure prevent the hydraulic coupling shaft from turning.

STARTUP CONCERNS

As installation of the first hydraulic coupling and steady bearing progressed, several concerns arose regarding these components. The most significant of these were:

- Alignment of components.
- Bearing loads and temperatures.

The alignment of all components was especially difficult to predetermine, because the actual rise from cold to hot conditions of the steady bearing and coupling were unknown. Fortunately, an optical shot of the generator shaft was made prior to and after shutdown. This showed the generator shaft to rise 18 mils (0.018 in) from the cold to the hot position. The steady bearing was predicted to rise only seven mils, the hydraulic coupling 14 mils. Although the alignment of the coupling and feed pump was simple to achieve, the generator shaft to steady bearing was significantly more difficult. The fact that the steady bearing grew only seven mils and had an internal clearance of 13 mils meant that the total of growth plus clearance minus one mil for upper and lower oil film (0.007 in + 0.013 in - 0.001 in - 0.001) equaled the total rise of the generator shaft, that is 18 mils. The concern was that if the journal surface was not properly centered in the steady bearing, the pads would be overloaded in either the hot or cold condition. Even when properly centered, it appeared that the loaded pads in the cold condition would be in the bottom, and that the load would shift during startup to being totally at the top. It was felt that the tilting-pad steady bearing would provide sufficient damping of shaft vibrations throughout the range.

The final alignment arrangement was for the steady bearing to be set one mil below the cold generator shaft, the hydraulic coupling set two mils above the generator shaft and the boiler feed pump was set four mils below the hydraulic coupling. The tolerance on the alignment was one mil.

At startup, temperatures of the steady bearing pads were monitored to determine the relative load on the pads. Three pads, two lower and one upper, were monitored for any anomalies. The results are shown in Figure 20. Although the turbine was started at time 0, the hydraulic coupling was not loaded until about 14 hours later. The results did not show any significant change in temperatures relative to each other. The reason for this became very clear when the shaft centerline position was plotted. The plot (Figure 21) showed that the shaft position only moved about seven mils which implies that the housing of the steady bearing grew perhaps 12 mils. Further checks have indicated the growth of the steady bearing tracks the generator growth through the load range. Oil temperature leaving the bearing is approximately 130°F.

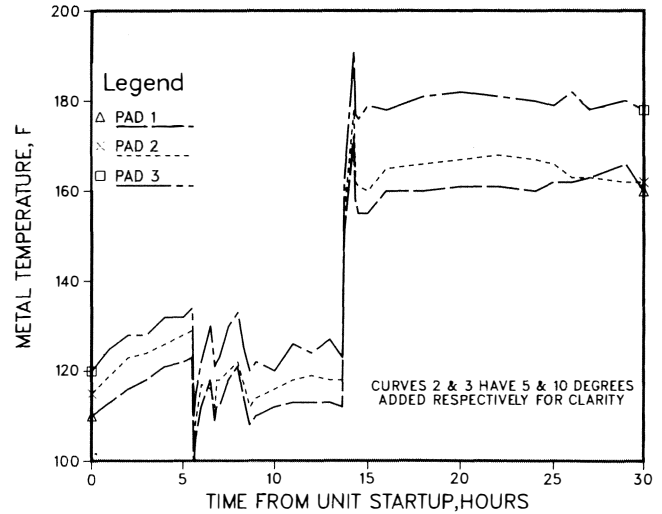

Figure 20. Bearing Temperatures at Unit Startup.

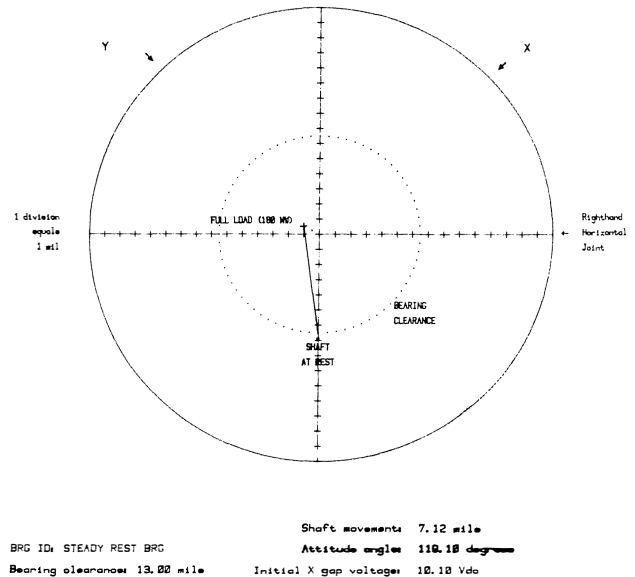

Figure 21. Shaft Position Plot.

RESULTS OF STARTUP

During installation, many precautions were taken to prevent startup problems. Many design details which would be typical for such an installation were improved to reduce the installation period. Although not required, all the existing oil piping was removed and replaced with 304 stainless steel pipe and valves. The oil reservoir was reused, but was first sandblasted and given a phenolic based coating. The choice of stainless steel and the coating was economically justified, since the need for pickling was eliminated, and the flushing operation would be greatly reduced.

The installation of the first hydraulic coupling was planned for a scheduled five week overhaul. To meet the schedule, demolition of existing piping and coupling began seven weeks earlier, while the unit operated on the steam turbine driven feed pump. Due to various delays, the initial startup occurred one week late. At that time, it was discovered that the main oil pumps were slightly oversized, since oil pressure at the coupling was much higher than design. Due to the lack of a pressure reducing valve, the main oil pump discharge relief valve was reset to allow recirculation and a subsequent lower pressure at the bearings. The valve manufacturer concurred with this operation, and after further testing and refinement of the coupling controls, the unit maximum emergency load of 191 MW was attained on March 12, 1985.

Final testing of the coupling occurred on March 20, 1985, at which time a maximum emergency unit load of 196 MW was reached. At 3600 cpm generator input and 85 percent scoop tube position, the boiler feed pump speed was recorded at 3525 cpm with a coupling slip of 2.08 percent (better than predicted).

The unit presently operates at a normal full load of 185 MW. This load occurs at 72 percent scoop tube position and a pump speed of 3453 cpm, with four percent slip. At this load, vibration of the coupling input and output shafts is only 1.4 mils. Steady bearing vibration (i.e., the generator shaft) is only 1.8 mils. These vibration levels include mechanical and electrical runout of approximately 0.5 mils for an actual vibration level of 0.9 mils and 1.3 mils, respectively. Vibration spectra shortly after startup are shown in Figures 22 and 23.

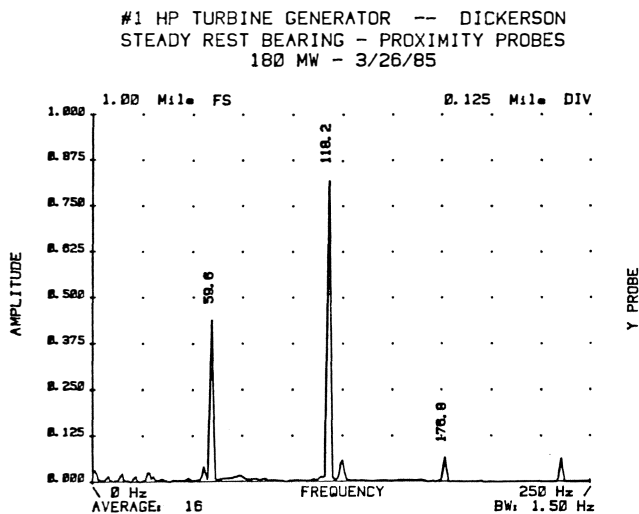

Figure 22. Vibration Spectrum—Steady Bearing Stub Shaft.

SUBSEQUENT SERVICE HISTORY

The second coupling was installed on Unit 2 during the fall of 1985. In early 1986, the coupling's scoop tube appeared to "stick" during low load operation, thus upsetting boiler feedwa-

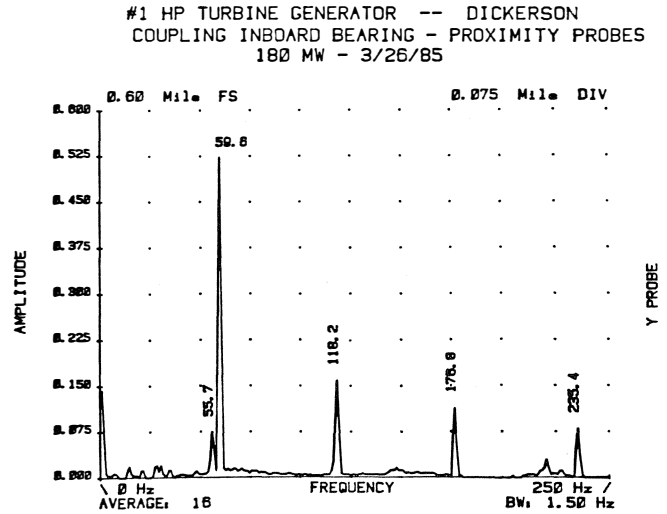

Figure 23. Vibration Spectrum—Hydraulic Coupling Input Shaft.

ter control. The unit's auxiliary boiler feed pump was then used at the lower unit loads to overcome the problem. An unrelated weekend shutdown allowed the maintenance shop to dismantle the coupling and examine the scoop tube.

Upon reassembly of the coupling and subsequent operation with the unit, the "sticking" problem disappeared. The scoop tube again allowed proper feedwater control throughout the full load range. Although the cause of the problem was never discovered, two other items of interest were examined.

First, it was determined that the hydraulic coupling could not be uncoupled from the main turbine-generator and disassembled, unless the steady bearing was also disassembled. The input shaft of the coupling was supported by two journal bearings, and was bolted to the floating element of the steady bearing. This element floats (via gear teeth) inside an outer hub which was the journal surface of the steady bearing. Consequently, the outboard end of this element had no support when it was disconnected from the hydraulic coupling input shaft. To alleviate this, the bearing manufacturer designed an auxiliary support bearing which could be temporarily attached to the coupling outboard end of the floating element; the coupling can then be unbolted and the turbine-generator operated without needing to disassemble the steady bearing. A cross-section diagram is shown Figure 24.

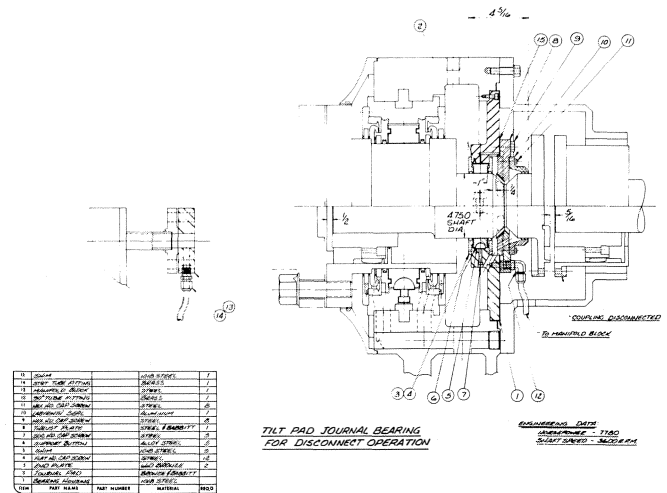

Figure 24. Auxiliary Support Bearing.

The second item of interest was a "hot" alignment of the coupling. After the weekend shutdown, the unit was brought back on-line using the auxiliary boiler feed pump. The unit was operated in this manner for several weeks until examination of the coupling was completed. During another unrelated weekend outage, the cold coupling, cold steady bearing and cold boiler feed pump then had to be aligned to the hot turbine-generator (normal cooldown time is five days). Since the baseplate shims had not been altered (i.e., elevation and horizontal offset was unchanged), all of the equipment had operated successfully when previously aligned, and the relative cooldown rate of the turbine-generator was unknown, it was decided that only a hot alignment check would be made. If the check were to reveal any major misalignment (possibly due to accidental upset of the equipment), then the turbine-generator would have to be cooled-down completely for another thorough cold alignment.

The major finding of the hot alignment check was that both the steady bearing and hydraulic coupling shaft center lines were off to one side of the turbine-generator shaft centerlines (by 6.5 mils and 10.0 mils, respectively). The engineers believed it was unlikely that both the steady bearing housing and coupling housing shifted during operation. Rather, it was more likely that the turbine-generator shaft was not in the true center of its bearings when the original cold alignment was done. This seemed possible, considering the elliptical bearings on the generator. During the original cold alignment, the turbine-generator lube oil was cold and the unit had been off turning gear for several days; shaft rotation was accomplished with a jack, which probably caused the shaft to ride up on one side of its bearings. During the hot alignment check, though, the lube oil was warm and the shaft had just come off turning gear; it was probably then in the true center of its bearings. A slight rubbing seen on the tilt-pad on one side of the steady bearing confirmed this conclusion. Although these positions were not ideal, the

previously successful operation of this equipment indicated the offsets to be acceptable. Subsequent operation after the weekend shutdown again produced low vibration and expected temperatures. Nevertheless, future cold alignments will attempt to avoid the untrue centering of the turbine-generator shaft.

CONCLUSION

The retrofit installation of any equipment can present interesting design challenges. Experience with this installation has demonstrated that these challenges can be met through the coordination of various engineering resources.

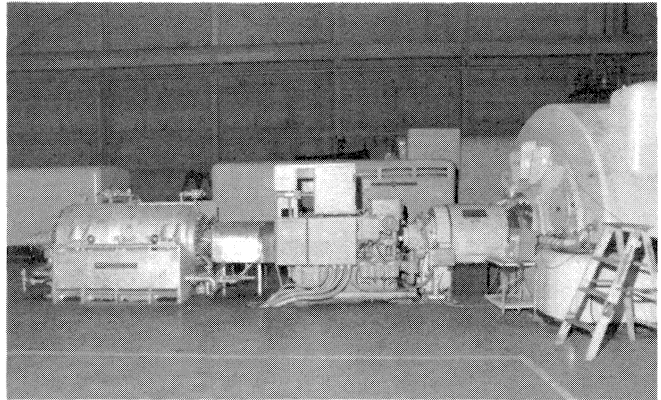

Figure 25. Completed Installation.

To date, the operation of hydraulic couplings for boiler feed pump drive service has proven to be reliable and the increased efficiency of variable speed shaft drive provides significant economic advantages over alternate drive systems. A view of the completed installation is shown in Figure 25.