

## EXPERIENCE WITH AN ONLINE CONDITION MONITORING SYSTEM

by

**Refah R. Unsal**

**Mechanical Engineering Specialist  
Phillips Petroleum Company Norway  
Tananger, Norway**

and

**Meherwan P. Boyce**

**President and CEO  
Boyce Engineering International, Incorporated  
Houston, Texas**

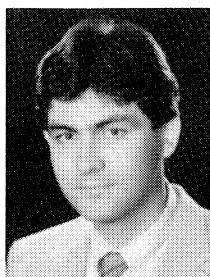

*Refah R. Unsal is the Mechanical Engineering Specialist in Condition Monitoring Systems, Vibration and Turbine/Control with Phillips Petroleum Company Norway.*

*Previously, he worked as an Associate Technical Systems Analyst where he was the Project Leader for a Pilot Condition Monitoring System Project to monitor four GE Frame 5002 machines at Ekofisk Tank platform, and participated in the development of a Corrosion Monitoring*

*Interface System for the Ekofisk field. His areas of interest are performance analysis, vibration analysis, rotordynamics, turbomachinery prognosis/diagnosis, systems analysis/design and programming.*

*Mr. Unsal received a B.S. degree in Electrical Engineering from Middle East Technical University of Ankara, Turkey, and an M.S. degree in Electrical Engineering from University of Birmingham, England.*



*Meherwan P. Boyce is President and CEO of Boyce Engineering International, Incorporated, in Houston, Texas. His past experience incorporates many academic and professional positions, including Professor of Mechanical Engineering, Founder, and first Director of the Turbomachinery Laboratory. He was also responsible for founding the Turbomachinery Symposium, which he chaired for eight years. His industrial positions*

*include Manager of Compressor and Turbine development at Curtiss Wright and Manager of Aerodynamics Technology at Fairchild Hiller Corporation. Dr. Boyce has authored more than 100 significant publications and technical reports and is the author of the Gas Turbine Engineering Handbook and has contributed to other major handbooks. He is a member of Phi Kappa Phi, Pi Tau Sigma, Sigma Xi, and Tau Beta Pi. He is also a member of ASME, SAE, NSPE, HESS and ASEE. In June 1985, Dr. Boyce was named a Fellow of the American Society of Mechanical Engineers.*

*Dr. Boyce was the 1974 recipient of ASME's Herbert Allen Award for Excellence and the 1973 recipient of the Ralph R. Teeter Award of SAE.*

*Dr. Boyce pioneered a breakthrough in technology through the development of a real time computer system (DATM4) which monitors, analyzes, diagnoses, and prognosticates performance of major turbomachinery. These systems are in use throughout the world.*

*Dr. Boyce received his Ph.D. in Mechanical Engineering from the University of Oklahoma.*

### ABSTRACT

A total online condition monitoring system has been in operation on the world's largest offshore facility located off the coast of Norway. The Ekofisk platforms are operated by the Phillips Petroleum Company Norway and supplies crude and natural gas. The system, which monitors performance, as well as mechanical parameters, has been operating for the past two years on four trains which are used for gas transmission from the platform to Emden, Germany. The system and the operating experience are described.

### INTRODUCTION

On the Phillips Petroleum Ekofisk platform located 296 km offshore Norway, is one of the largest and most complete turbomachinery condition monitoring systems (DATM4). It was completed and put into operation in January, 1987 at a cost of U. S. \$1.7 MM.

This pilot condition monitoring system (PCMS) is a real time, online system used to monitor aerothermal, thermodynamic, process, vibration and event variables of four frame 5002 GE turbines driving Dresser Clark gas pipeline compressors offshore at the Ekofisk 2/4 tank platform. Each turbine is coupled to a Dresser Clark nine stage (5 × 4 back-to-back) single shaft compressor with a capacity of 19MMM<sup>3</sup>/day. The gas turbines operate in a simple cycle on natural gas. The gas turbines are rated at 22.4 MW(ISO) and are equipped with the General Electric Speedtronic MK2 Control system. A schematic overview of one of the trains being monitored is shown in Figure 1. As background, a tabulation of the operating and maintenance history of these four trains is shown in Figure 2 [1].

Out of these four monitored gas pipeline units, one is normally kept as a standby and the rest of the units run continuously. The three units consume approximately 18.4 mmscf of fuel gas per day which amounts to \$U.S. 16.8 million dollars/year based on \$2.50/MM Btu. It is easy to see the enormous amount

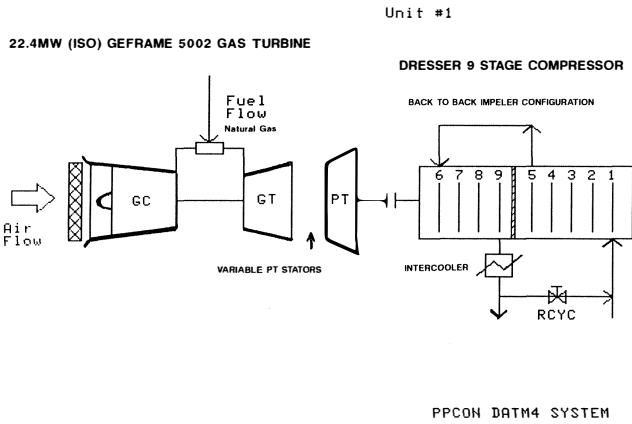

Figure 1. Gas Turbine-Compressor Train Being Monitored.

Platform	2/4 Tank			
Unit	A	B	C	D
FIRED HOURS x 10 <sup>3</sup>	53	52	52	52
FIRED STARTS	655	725	593	626
HOURS/START	81	72	88	83
AVAILABILITY %	85,2	80,0	90,4	85,6
RELIABILITY %	96,9	95,7	96,9	96,7
USE FACTOR %	67,5	65,3	66,3	65,2
YEAR OF COMMISSIONING	77	77	77	77
MAJOR COMPONENTS REPLACED				
FIRST STAGE NOZZLE ASSEMBLY	2	2	1	2
COMBUSTION LINER SETS	2	2	2	2
TRANSITION PIECE SETS	1	1	1	1
COMPRESSOR BLADE SETS	*	1	1	1
1ST STAGE TURBINE BLADES		1	3	
BEARING NO. 1	2	1	1	1
BEARING NO. 2	2	1	1	1
BEARING NO. 3	1	1	1	1
BEARING NO. 4				1
HP THRUST	1	1	1	1
LP THRUST				1

Note: Availability and Reliability figures are for combined driver and driven equipment

\* First three stages only

Figure 2. Past History of Gas Turbine Compressor Sets Being Monitored [1].

of energy involved. As these units consume so much energy, monitoring is required to ensure that degradation is limited and that operation at least approaches its optimum efficiency. Maintenance actions can also be taken to maintain this efficiency within acceptable economic limits. A one to two percent efficiency related saving can amount to between \$170,000-340,000/year.

The installed system has two separate computer systems linked via satellite. All information collected on the platform is both available offshore for operators and turbine engineers and onshore in their Tananger office for maintenance specialists via a satellite connection. An overview of the system is shown in Figure 3.

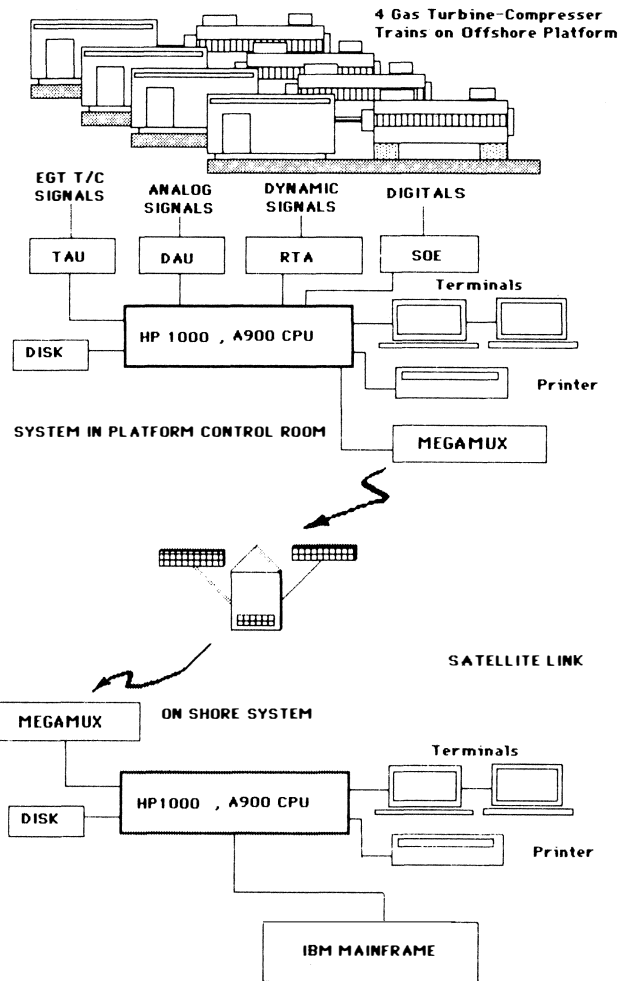

Figure 3. Conceptual Overview of the Condition Monitoring System.

The project was justified on the basis of fuel, manpower and maintenance savings. Major premises are: saving fuel by monitoring performance to operate the machine more effectively, lowering the maintenance costs by using preventive/predictive condition monitoring techniques to reduce unscheduled downtime and excessive mechanical deterioration, and perform inspections as needed instead of on a fixed schedule.

Some intangible benefits are: maximizing reliability of the gas pipeline facility and availability of the machinery, reducing number of catastrophic shutdowns, and having a reliable record of what really is the underlying cause when a shutdown occurs.

Manpower savings are achieved by locating the mechanical specialists onshore and transmitting operational data over the satellite for evaluation. These savings together could show a rate of return which would be less than one year.

The system is designed to evaluate the performance of the turbines and compressors, both from an aerothermal and mechanical point of view, thus providing analysis and diagnostics so that catastrophic failures can be avoided.

SYSTEM DESCRIPTION

The following three areas will be discussed:

- Input Signals and Instrumentation Considerations
- Hardware Considerations
- User Interface

### *Input Signals and Instrumentation Considerations*

The total number of points handled by the system exceeds 1000 points. There are some 800 measured points and 640 calculated points.

These measured points are divided into three major categories: analog, digital and dynamic. Analog inputs are sensor inputs from flow, temperature and pressure transducers. Digital inputs are interlock status and other on-off type signals. Dynamic input refers to rapidly changing items such as the vibration signals from which FFTs are performed.

There are 100 analog signals per unit (total 400) that are read every three seconds. These signals are input from instrumentation such as thermocouples, rtd's, flow, pressure and overall values of vibration from proximator, accelerometer and velocity probes.

Data acquisition hardware for the analog signals consists of a multiplexer voltmeter arrangement with an HP-IB link to send the data periodically to the host computer. In the case of the exhaust temperature data from the GE Speedtronic IIs, special modification had to be made to read the values. The modification consisted of putting all the thermocouples into a temperature averaging unit (TAU) before they were averaged and then sending the digital averaged temperature control signal to the controller rather than the hardware averaged signal. The digital signals are directly taken into a sequence of events recorder.

The dynamic inputs included all the train proximity probes as well as data from the accelerometers located on the turbine. It consists of 25 signals per unit (total 100 which can be measured up to 16 channels simultaneously). Communication to the host computer is through an HP-IB link. The signals are divided into two sections. One is dedicated to signals from high pressure (HP) rotors and the other from low pressure (LP) rotors of the machinery being monitored. The triggering source for the analyzers is the Keyphasor signal from each shaft. One spectrum analyzer is capable of capturing data from eight channels simultaneously, when a trip occurs. The analyses provided by the spectrum analyzers are: frequency spectra, order tracking spectra and time base samples.

Instrument accuracy, reliability and repeatability is an important area for the design of any condition monitoring system. The software conducts sensor credibility checks and flags the sensor suspected. In some cases, the best estimate for the discrepant error is made by computational techniques.

### *Hardware Considerations*

#### *Host Computer and Communications*

The system uses the HP1000 series A900 minicomputer as the online host computer. It is situated on 2/4-tank platform at Ekofisk. Its main functions are collection and storage of all data and presentation to offshore users. It also acts as the communications mode for sending data to another HP1000 series A900 computer situated onshore at the Phillips Tananger base. The connection is a 9600 baud satellite link.

The HP operating system being used is RTE-A and the network software used to communicate through the satellite is HP DS/1000-IV. The onshore HP1000 has a 9600 band HASP link using HP MRJE/1000 software to an IBM mainframe computer.

This link is utilized to transfer gas properties tables from IBM to HP1000 onshore and eventually to the offshore online system for use in aerothermal calculations. Both computer systems (on and off shore) have operator interface stations, mass storage and printers.

#### *User Interface*

In order to ensure user acceptability, a totally menu driven system was used. Extensive use of graphic displays is used and

operators can access any information required without knowledge of special computer commands. Machine schematic print-outs allow operators to pick whatever data (spectrum, trend, performance maps) they want. Some typical displays are shown in Figure 4. The performance data from the gas turbine are shown in Figure 4 (a). The centrifugal compressor unit performance data are shown in Figure 4 (b). The vibration measurement group on the train is presented in Figure 4 (c) while the bearing temperature group is reflected in Figure 4 (d). Using this pictorial information, any measured point or computed value can be selected and viewed in any format desired.

### **AEROTHERMAL AND MECHANICAL SYSTEM MONITORING AND ANALYSIS**

Analysis is a process of manipulating engineering data and presenting it in a useful format. The condition monitoring system conducts two major analyses.

They are:

- Aerothermal analysis, and
- Mechanical analysis.

Aerothermal analysis allows a determination of overall efficiencies, component efficiencies, and heat balances which could enable operation close to design efficiency. Determination of component efficiencies also allows the detection of problems such as compressor and turbine fouling, and several other problems that often manifest themselves as performance changes.

Mechanical analysis includes vibration analysis, bearing temperature analysis and lube/seal oil analysis, and is an effective tool in detecting incipient failures. Several of these problems could be rotordynamic related. Effective machinery condition monitoring requires both types of analysis.

#### *Aerothermal Analysis*

The need for aerothermal analysis arises from the fact that while overall deterioration may be evident in a turbomachine, determining the specific component (or set of components) causing the deterioration may not always be possible without aerothermal analysis. Moreover, efficient operation of turbomachines is of utmost importance by virtue of the fuel cost dollar savings obtained by operating at the design efficiency point. Maintenance scheduling can also be based on specific performance decrements. Usually it is not practical on an operational turbine to measure pressures and temperatures as total properties, but for the purpose of condition monitoring, static properties with corrections can be used. It should be borne in mind that absolutely correct values are not as important as repeatability. Providing measurements are repeatable within a reasonable tolerance, useful trends can be made. The point of the exercise is to record changes.

Various assumptions have to be made to get certain measurements. Air flow into the gas turbine compressor, for example is a difficult measurement. Static pressure and temperature are measured at the compressor inlet scroll. The geometric area can be determined either from drawings or by measurement. With static conditions at the scroll determined, a total measurement is needed to complete the calculation. The ambient temperature and pressure are recorded and are used in calculating the air mass flow into the compressor. The total pressure at the compressor bellmouth inlet is assumed to be a function of the atmospheric pressure and the total temperature is the ambient temperature. The assumption, of course, is that the flow through the filter system and ducting is isentropic (reversible). Although this is not strictly true, the actual error will be approximately constant especially for machines like the dual shaft GE Frame 5002, which has constant gas generator compressor speed. With these

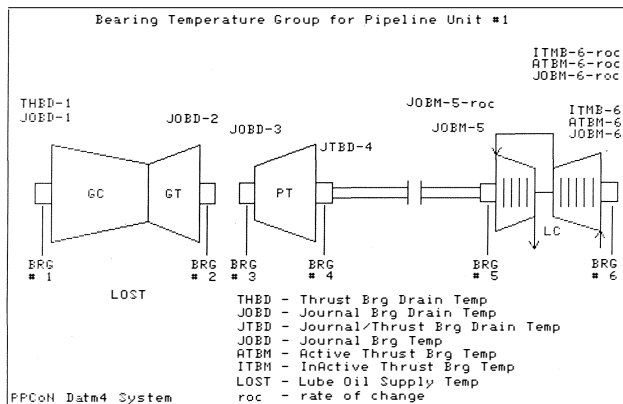
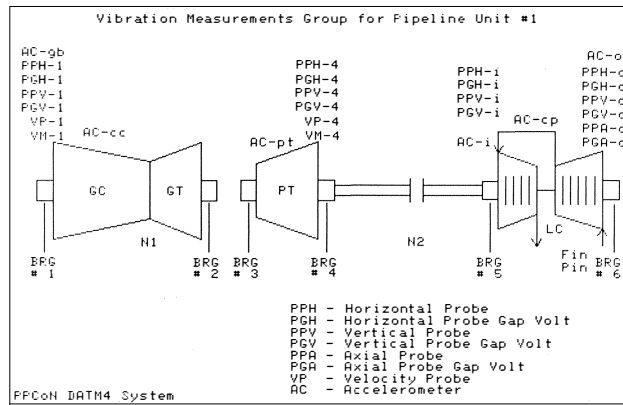
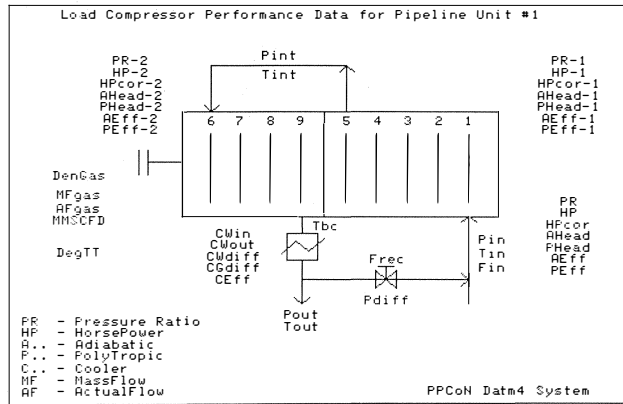
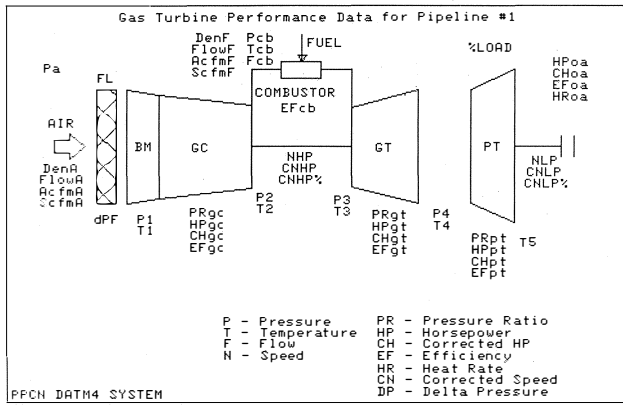

Figure 4. Schematic Diagrams Showing User Interface.

measurements, the compressor inlet flow can be estimated taking into consideration the corrected speed.

Once a given set of performance parameters is computed, it is necessary for these to be adjusted to some predetermined set of conditions (such as ISO conditions of 60°F and 14.7 psia). The corrected parameters taken from a new and healthy machine often form an aerothermal baseline. Details regarding correction of parameters are provided in Figure 5.

Gas Turbine Aerothermal Performance Equations for Correction to Standard-Day Conditions

Factors for Correction to Standard-Day Temperature & Pressure Conditions

Assumed standard-day pressure	14.7 psia
Assumed standard-day temperature	60°F (520°R)

Conditions of test

Inlet temperature	T <sub>i</sub> , °R
Inlet pressure	P <sub>i</sub> , psia

Corrected compressor discharge temperature = (Observed temperature) (520/T<sub>i</sub>)

Corrected compressor discharge pressure = (Observed pressure) (14.7/P<sub>i</sub>)

Corrected speed = (Observed speed) √(520/T<sub>i</sub>)

Corrected air flow = (Observed flow) (14.7/P<sub>i</sub>) √(T<sub>i</sub>/520)

Corrected horsepower = (Observed power) (14.7/P<sub>i</sub>) √(T<sub>i</sub>/520)

Figure 5. Performance Correction Factors.

The condition monitoring system should be able to discriminate between performance decrements caused by off-design operation and performance degradation due to problems.

It is not practical to measure the turbine inlet temperature, so this has to be estimated by a heat balance over the axial compressor and the gas generator turbine, knowing the inter-turbine temperature. If the inter-turbine temperature measurement is not available, then it is estimated by doing a heat balance on the power turbine and the load compressor. Combustor efficiency calculation is corrected by a heat loss coefficient to account for the heat radiated from the turbine and energy used to raise the fuel gas temperature.

The mass flow into the turbine changes as it passes through the gas path. Some flow is extracted for sealing while fuel flow is added in the combustor. It turns out in practice that unless compressor flow is used external to the gas turbine, the amount of air flow used for cooling, as well as sealing, which can be considered as leakage air, is approximately equal to the volume of gas added in the combustor.

With the process compressor calculations, one must be careful to allow for the fact that the fluid is not a perfect gas. Allowance for compressibility must be made. The scheme being used involves the following steps:

- Get the gas constituents from a gas analysis.
- Produce gas properties tables with the given gas constituents for given pressure and temperatures.
- Access the look up tables from the aerothermal programs to do temperature entropy calculations to determine isentropic and polytropic efficiencies.

Mechanical Monitoring and Analysis

This function is mainly responsible for analyzing data connecting with mechanical condition of machinery. The condition monitoring system offers two types of mechanical analyses. These are:

- Vibration signature monitoring and analysis, and
- Bearing/Seal system monitoring and analysis.

### Vibration Signature Monitoring and Analysis

It has been found in industrial practice that good correlation exists between the characteristics vibration signatures of machines and their relative condition. The different components of a machine vibrate at one or more discrete frequencies, and different malfunctions in a given component can cause vibrations at different discrete frequencies. It is the combination of these discrete frequency vibrations that result in the complex vibration waveform at the measurement point. Therefore, a common and effective method of analyzing the measured vibration signal is to reduce it to its discrete frequency components. The result of this type of analysis usually presented as a plot of amplitude versus frequency, is what is commonly referred to as the "vibration signature" of the machine. Vibration Signature Analysis simply involves comparing the current vibration signature of a machine to a baseline vibration signature taken when the machine was operating satisfactorily.

The system spectrum analyzer performs analog to digital conversion and Fast Fourier Transform (FFT) on each incoming time domain vibration signal. The output of the analyzer is a digitized vibration spectrum and is stored on disc. The user can examine any of the stored spectra individually or in two or three dimensional multiple spectra diagrams, i.e., Waterfall and Cascade diagrams.

The software also includes a high performance cascade spectra capability. This allows excellent presentation of high density cascades (Waterfall diagrams) that allow the detection of a variety of transient problems. The cascades may be either time or rpm dependent and are excellent diagnostic tools during startup and shutdown.

### Bearing/Seal System Monitoring and Analysis

This analysis involves measuring the bearing metal temperature, the lube oil inlet temperature, and any other lube/seal oil temperature points.

The program calculates the rate of change on the bearing metal temperature and differential temperature between the metal and the oil. The rate of change eliminates the problem of slow thermocouple response. The differential temperature provides good indication of bearing loading.

## APPLICATION SOFTWARE MODULES AND THEIR USE

There are several main modules that the user is provided with as a menu on the screen. These are:

- *Performance Maps*. This contains a variety of performance maps for the compressor and gas turbine.
- *Summary Charts*. This contains charts displaying different groups of analog data.
- *Trends*. This allows the user to obtain a graphical display of historical data.
- *Individual Points*. This allows the user to view any individual analog point.
- *Vibration Snapshots*. This provides the user with on demand vibration spectra, orbits or time records.
- *Vibration Analysis*. This allows the display of any of the "automatically" taken spectra.
- *Transient Analysis*. This allows the user to view vibration data acquired during startup/shutdown.
- *Status and Alarms*. This provides a current and historical display of machine status and alarms.
- *Operator Logs*. This allows the operator to enter any event/comment/note of interest (similar to operator log sheet).

- *Data Capture*. This module allows access to 90 minutes of raw data.

- *Startup File*. This provides data automatically triggered by digital events. Display formats are similar to the data capture module.

- *Specialized Graphs*. This has a collection of special outputs (EGT Profile), bar charts, etc.

- *Daily Report*. This provides a summary of events for a past defined time period.

- *Offline System*. This provides a set of maintenance support alignment and balancing programs that can be used in an offline mode.

- *Database Setup*. This is a module that permits an authorized user to make routine modifications/updates to the database.

Some of the key modules along with some application examples are shown later.

### Performance Maps

The performance map menu provides the user with a choice of aerothermal performance maps that allows the user to visualize the thermodynamic behavior of the machine under consideration. The maps show the live operating point superimposed on the operating characteristics map of the machine.

Engineers and operators can visualize and optimize the on-line operation with respect to the operating envelope of the machine.

This allows safe operation and allows an insight into operating efficiencies, proximity to surge and how the machine behaves compared to its design point. Deterioration in performance can be seen by using these maps. The ability to simultaneously view four maps provides the user with a quick representation of the operation.

A performance map is the expected machinery behavior under different operating conditions. This is normally used as a baseline to measure how well a machine is performing under different operating conditions. The module plots the designed performance map and places a live operating point on the map. The X and Y coordinates of the operating point are also displayed at the bottom right hand corner. In addition to these two values, three more user selected values can be displayed at the same area. All five values are updated continuously. A sample map for the load compressor is shown in Figure 6. Four maps in Figure 7 are shown on a screen which gives relationship between the compressor and the turbine. This is very useful in determining the relationships between the turbine and the compressors.

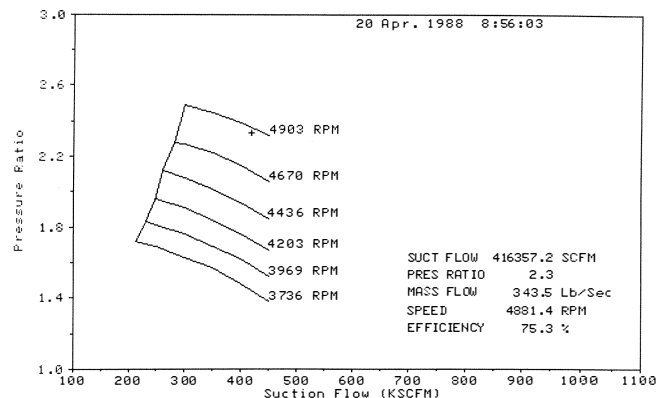

Figure 6. Compressor Surge Map.

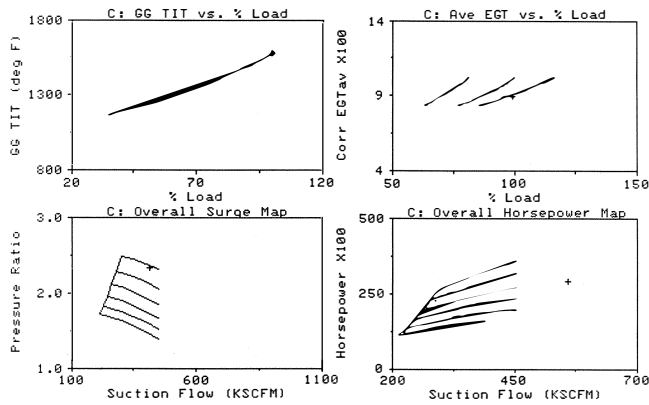

Figure 7. Multiple Performance Maps.

By monitoring the operating point of the process compressor, it is possible to see if the compressor is operating at the higher efficiencies close to the surge line. During turndown operation, minimizing recirculation, and at the same time operating close to the surge line without going into surge, can provide considerable fuel savings. This is possible if the operator can see the operating point dynamically changing on a performance map. The system also calculates a surge factor, a value developed as a function of the velocity perpendicular to the shroud and the pressure gradient, which signals the onset of surge.

The surge factor accurately calculates the surge margin on each wheel and is used to illustrate to the operator where he is from surge on each wheel. The bar charts for each wheel are shown in Figure 8.

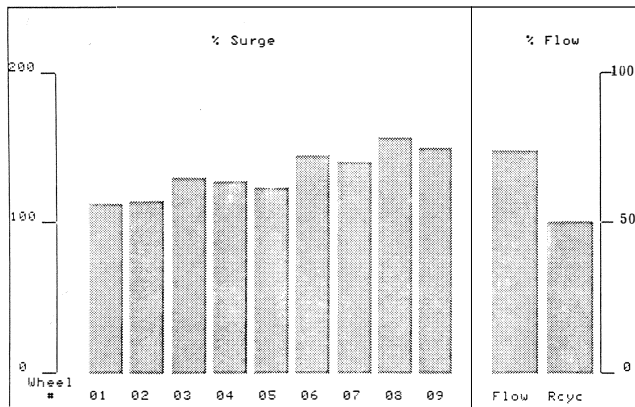

Figure 8. Surge Bar Chart.

The life cycle analysis chart calculates the actual life used as a function of the following parameters: blade metal temperature, number of starts, compressor discharge temperature, blade loading and the number of forced shutdowns. The system used the compressor discharge temperature and the computation of the turbine inlet temperature to calculate the blade metal temperature and with the turbine loading the Larson Miller parameter is computed. This establishes a relationship between temperature and time for various metals. The number of starts and forced trips also hold heavily to hours operated.

It is important to note that while summary charts display data in numeric fashion, some displays are available in bar chart or polar plot format. A polar plot of the gas turbine exhaust gas temperature profile is shown in Figure 9. This sort of display permits a quick visual evaluation of operating conditions.

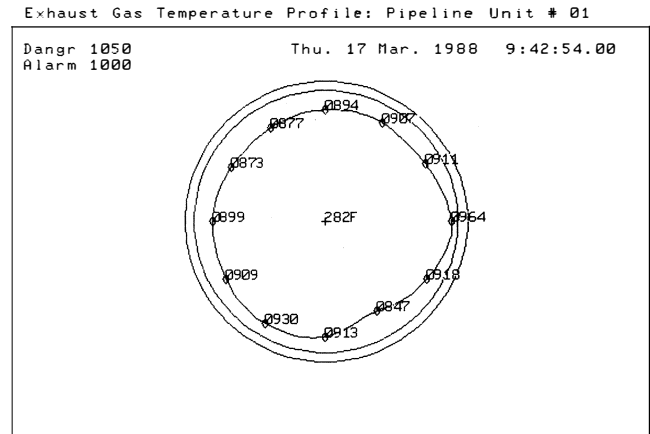

Figure 9. Gas Turbine Exhaust Gas Temperature Profile.

### Summary Charts

The summary charts are a dynamic tabular representation of numerical data that describes the operating behavior of the machines. It is updated every three seconds. A wide variety of these charts is available. Summary charts consist of both measured and calculated variables.

The summary charts are means of obtaining detailed information about a group of sensors of a particular type or a group of sensors pertaining to the vibration, performance or auxiliary system performance (e.g., lube and seal oil system). A particular summary chart can be made to display a wide variety of values. This particular module allows the user to display groups of data from the machine train. The variables are grouped into the following charts.

- Exhaust gas temperature summary chart
- Wheel space temperature summary chart
- Vibration measurement summary chart
- Bearing/lube temperature summary chart
- Gas turbine performance data summary chart
- Compressor performance data summary chart
- Flow measurement summary chart
- Gas turbine control summary chart.

The charts may display any one of the following:

- Current values
- Maximum value (over a six hour period)
- Minimum value
- Average value (past 24 hr)
- Baseline value
- Upper alarm limit
- Lower alarm limit
- Upper danger limit
- Lower danger limit
- Raw data (voltages)

Some summary charts for the gas turbine and the load compressor are shown in Figure 10. The charts show that the gas turbine is operating at a thermal efficiency of 21.6 percent and a turbine inlet temperature of 1517°F. The exhaust gas temperature is at an average of 876°F with maximum spread of 99.6. The load compressor is operating at a polytropic efficiency of 74.4 percent and a pressure ratio of 2.24.

Gas Turbine Aerothermal Data Summary Chart for Unit #3

23 Mar. 1988 13:12:01

CURRENT VALUES	Overall	GT Comp	Combustor	GG Turb	PT Turb
Actual Flow ( ACFM )	195880		283.6		
Mass Flow ( Lbs/Sec )	245.7		4.3		
Inlet Pressure ( Psia )	12.0			109.7	35.2
Inlet Temp ( Deg F )	50.8			1517.3	1119.5
Outlet Pressure ( Psig )	101.1				
Outlet Temp ( Deg F )	518.9				863.9
Shaft Speed ( RPM )	5064.2				4735.8
Pressure Ratio	8.3			3.1	2.4
Horsepower ( HP )	27446.4	41983.3		43743.3	27446.4
Corr Horsepower ( HP )	28699.9	43900.0		45740.0	28699.9
Efficiency ( % )	21.6	87.9	91.7	80.8	78.2
Corr Speed ( RPM )		5104.8			4773.8
Heat Rate ( Btu/Hp-Hr )	11803.3				
Corr EGT ( Deg F )					885.2
Corr Speed ( % )		105.9			102.2
Load ( % )					90.0

Exhaust Gas Temperature (EGT) Chart for Unit #3

19 Apr. 1988 16:46:32

CURRENT VALUES	Spread
EGT # 1 & Spread ( 1 - 2 )	911.4
EGT # 2 & Spread ( 2 - 3 )	940.6
EGT # 3 & Spread ( 3 - 4 )	892.5
EGT # 4 & Spread ( 4 - 5 )	885.6
EGT # 5 & Spread ( 5 - 6 )	904.5
EGT # 6 & Spread ( 6 - 7 )	920.0
EGT # 7 & Spread ( 7 - 8 )	923.4
EGT # 8 & Spread ( 8 - 9 )	918.3
EGT # 9 & Spread ( 9 - 10 )	916.5
EGT # 10 & Spread ( 10 - 11 )	909.7
EGT # 11 & Spread ( 11 - 12 )	890.8
EGT # 12 & Spread ( 12 - 1 )	901.1
Tx - EGT Average	909.7
Min EGT & Max EGT	885.6 940.6
Max EGT Spread & (Max EGT Spread)/Tx	54.9 .060
Channel A1 Over-Temperature	899.4
Channel B1 Over-Temperature	887.4

Load Compressor Aerothermal Data Summary Chart for Unit #3

23 Mar. 1988 13:13:30

CURRENT VALUES	1st Stage Suction	InterStage	2nd Stage DisCharge	Overall
Gas Flows	331.9	>Lbs/Sec 6073.7	>ACFM 579.2	>MMSCFD
Pressure ( Psig )	824.4	1311.0	1882.2	
Temperature ( Deg F )	60.8	140.8	192.0	
LP Shaft Speed ( RPM )	4745.2			
Pressure Ratio		1.6	1.4	2.3
HorsePower ( HP )		16913.3	10394.0	27307.3
Corr HorsePower ( HP )		18022.2	9847.2	29097.4
Adiabatic Head ( Ft )		17675.5	15805.5	32723.0
Polytropic Head ( Ft )		18504.4	14825.5	33026.9
Adiab Efficiency ( % )		62.7	95.7	73.8
Poly Efficiency ( % )		65.6	89.8	74.4
Cooler Water Temp ( Deg F )	INVALID	>Inlet 79.6	>Outlet 100.1	>Diff
Cooler Gas Temp ( Deg F )	INVALID	>Inlet 192.0	>Outlet 100.1	>Diff
Cooler Efficiency ( % )	INVALID			
DeGassing Tank ( Deg F )	152.1a			

Figure 10. Summary Charts.

Trends

The trends module permits the user to obtain plots of any measured or calculated parameter over a wide choice of time frames. This feature allows the user to examine the time dependent vibrations or other parameters that occur in the machine.

The trends permit the user to see how much machine behavior varies over time. This feature is most important from a condition monitoring standpoint. The ability to select and simultaneously view trends of four variables helps in identifying inter-relationships in machines behavior, for example, the effect of load on vibration, etc.

Trending is used to obtain predictions which would be helpful in the scheduling of maintenance. The system has hourly, monthly and yearly trending, and prediction capabilities. The prediction allow the user to predict a time when conditions will have deteriorated to a point demanding maintenance.

A trend of gas turbine air filter differential pressure vs time is shown in Figure 11.

Vibration Snapshots

This module permits the user to obtain spectra, orbits or time waveform pictures from vibration sensors on the machine. This allows the user to examine the vibration behavior on demand, i.e., whenever he desires to look at a particular point. The spec-

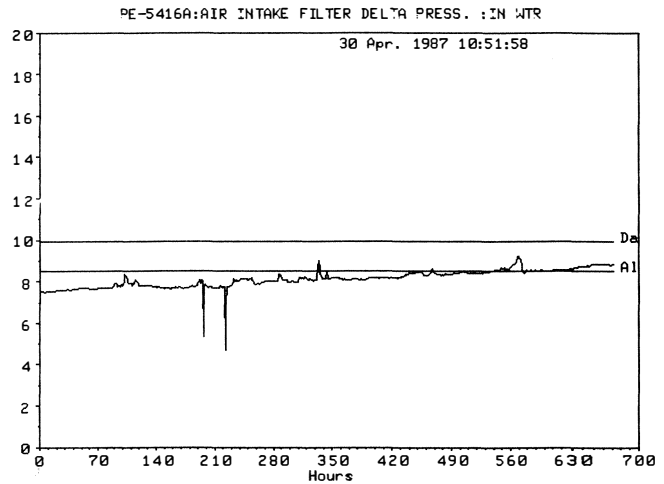

Figure 11. Trend of Intake Filter Differential Pressure.

trum feature permits viewing of any spectrum of choice. Orbits can only be obtained where X and Y proximity probes exist. Time waveforms can be obtained for any vibration signal.

This tool is useful in troubleshooting vibration problems. The spectrum analysis feature permits representation of the vibration in the frequency domain. The orbits show a representation of the shaft movement in the bearing. The time waveform provides the time amplitude trace of the vibration waveform. The choice of display depends on the objectives of the user.

Orbits

The orbit orientations are presented on the screen with the key phasor at the three o'clock position, i.e., the orbit is adjusted to this frame of reference. The outer circle is an amplitude reference circle and the value it represents (in mils/microns) is presented on the screen. Figures 12, 13 and 14 show representations of orbit, spectrum and time waveform snapshots, respectively.

Vibration Analysis

This module allows the access and management of all the spectra that are automatically acquired by the condition monitoring system. There are two ways in which spectra are acquired:

- Each vibration probe on the train, or a user defined set of probes, is scanned on a periodic basis (typically, every four

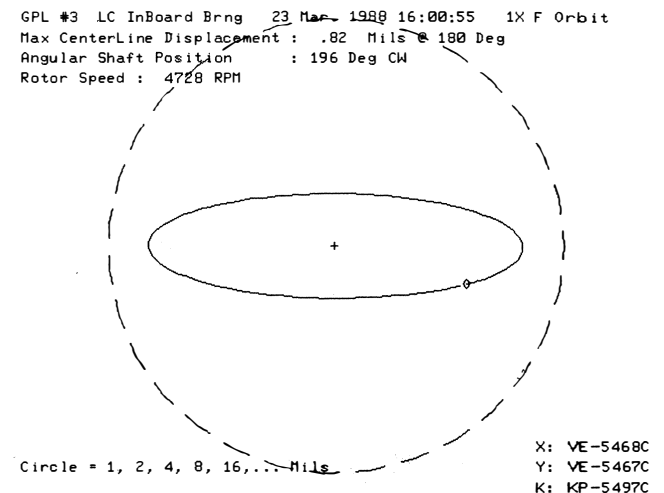

Figure 12. Orbit Representation.

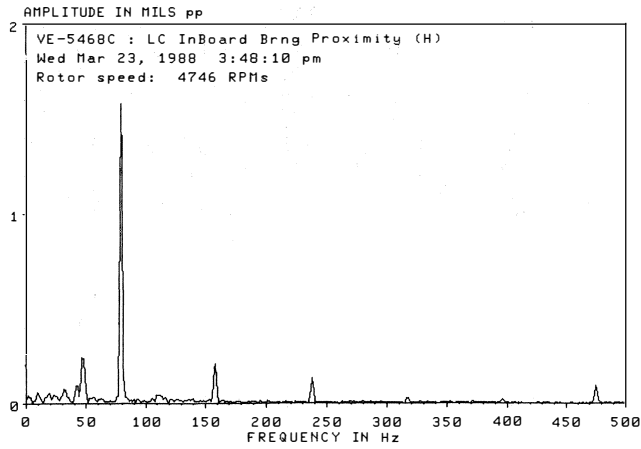

Figure 13. Spectrum Snapshot.

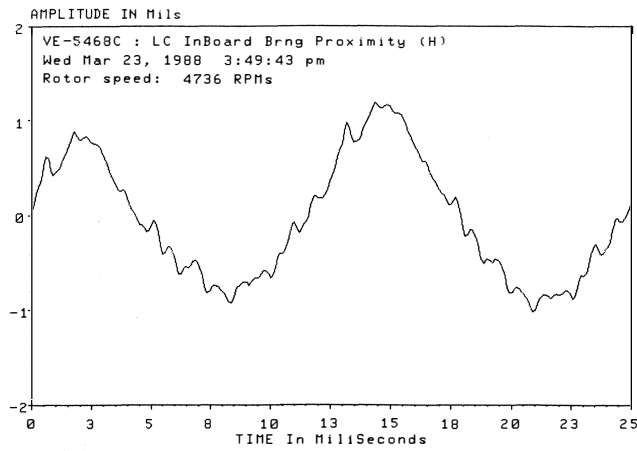

Figure 14. Time Waveform.

hours) and a spectrum is taken. The four hour spectrum scan rate is user definable. A set of 150 spectra for *each* probe are stored in a file on a first-in-first-out basis. This means that at any time one can view up to 560 hr or about 23 days worth of spectral history per vibration probe on the train. In order to manage and for the user review of the data, the vibration analysis module is to be used.

- If a set of user defined sensors go into alarm on overall value, then this can trigger an accelerated rate of spectra collection on a set of associated set of probes. Alarm limits are set dependent on the frequency and type of probe. For example, if a sudden increase in overall vibration on a particular bearing is found, this may cause the system to concentrate on associated proximity probes and increase the spectrum scans on those points. Also various analog points such as compressor discharge pressure or exhaust temperature can initiate a vibration analysis if they exceed or decrease beyond certain limits. This is a very valuable condition monitoring feature as it allows the user to view the changes in vibration spectral behavior over time. This allows the detection of the growth of unusual peaks and examination of time dependent changes that might have occurred. There are several ways in which the data may be viewed:

*Cascades* or "Waterfall" of a number of spectra (up to 150 stacked spectra at a time). Typically choosing about 50-60 consecutive spectra will provide the best visual resolution. The starting and ending spectra numbers have to be specified. This

is done by the operator by his filling in an easy to use form. The cascade permits a quick detection of problems as small changes and the appearance of new or undesirable peaks (e.g., a subsynchronous vibration peak) can be detected.

*Five Spectra* of the spectra available of any particular user chosen point. For example, the user may decide to pick spectrum numbers 1, 35, 70, 105, 130, and 150 for display. The five spectra will then be displayed on the screen. This feature permits a more detailed examination of the spectra. Figure 15 shows a five spectra representation. Alarm and danger spectral component limits are shown in Figure 16.

*Transient Analysis*

This module is a very useful feature of DATM4 that allows the user to review the vibration data that is acquired during startups, shutdowns or other transient events. Data may be viewed as Cascades, Nyquists or Bodé plots as shown in Figures 17, 18 and 19.

After any transient event, the user may wish to examine the vibration behavior of the point(s) chosen. In order to do this, he would use this module. This module allows the user to define the format of the display of the transient event. He can choose between Cascade, Nyquist or Bodé plots. The Cascade program allows the user to fix the first/last spectra and the spectra increment.

This system is set up to lock onto the vibration probe exhibiting the highest amplitude upon detection of a trip. Spectra are acquired for this primary probe and its associated probe during the machine rundown. Each trip is automatically logged to disc and number and date assigned to it for identification purposes.

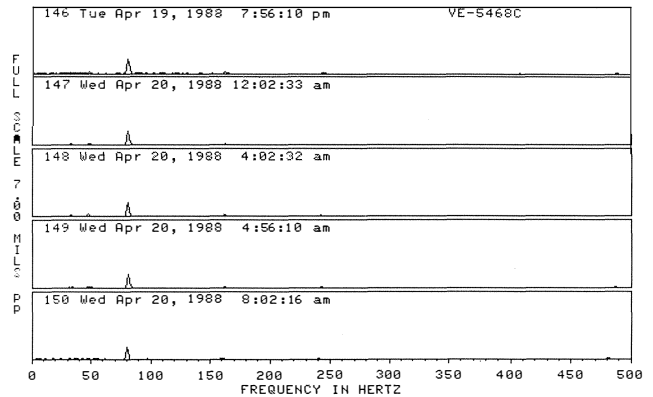

Figure 15. Five Spectra Representation.

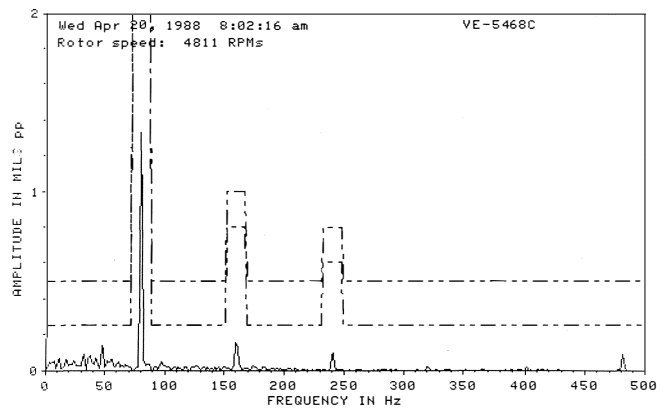

Figure 16. Spectrum Showing Frequency Related Limits.



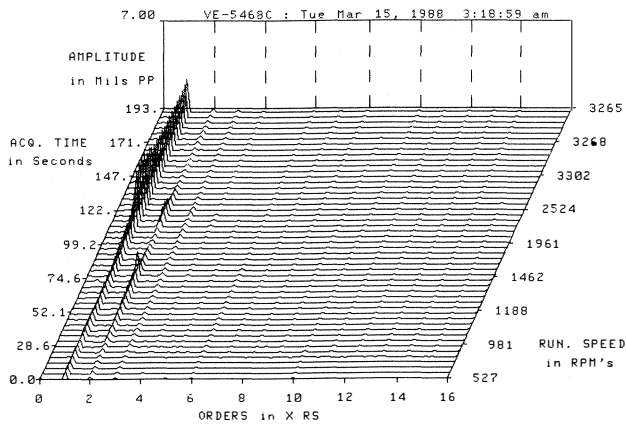

Figure 17. Special Order Cascade.

VE-5468C : Tue Mar 15, 1988 3:18:59 am NYQUIST DIAGRAM  
 Max displacement: 4.46 Mills pp, 39 deg @ 2477 RPM

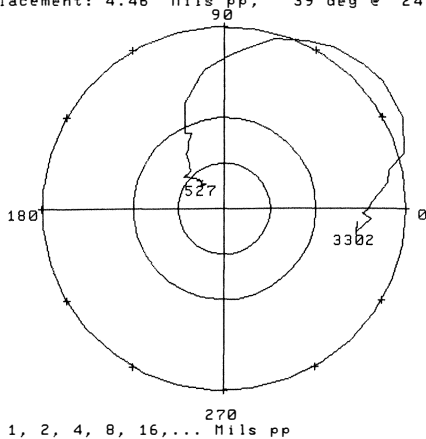

Figure 18. Nyquist Diagram.

VE-5468C : Tue Mar 15, 1988 3:18:59 am BODE DIAGRAM

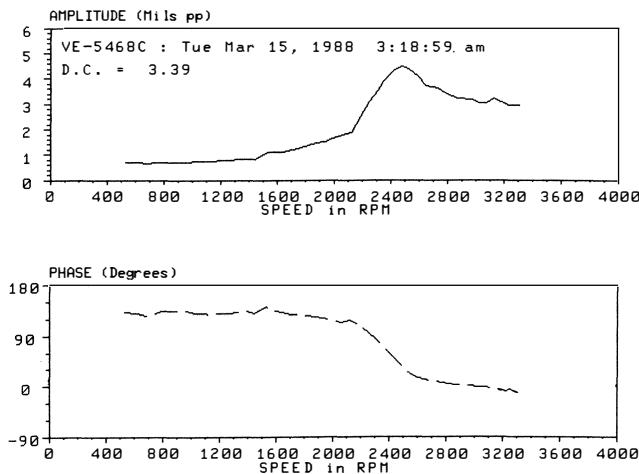

Figure 19. Bode Plot.

This module is set up to list all of the vibration trips occurring on any machine unit. From the listing of vibration trips, an individual trip can be selected for close examination.

Data Capture

Data capture is a feature that allows the freezing of approximately 90 minutes of raw data (i.e., "as scanned" data without any averaging) either when a trip occurs or upon user command. About five minutes of data *after* the trip will also be frozen. There are three files for storing captured data. One of these is always actively windowing the "raw" data and the other two contain the last two captures. This module is activated upon machine trip. Keeping the raw data that occurs prior to, and after the trip allows the user to observe exactly what happened that may have initiated the trip. The captured data can be displayed in performance map format, summary charts, trends format, or as X-Y plots. Often it is the latter (trend format) that provides a good picture of the events leading up to the problem.

The events leading to the trip can be viewed like a video, scanning forward, backward and with a freeze button. This is an important tool to study (almost in slow motion) the underlying causes that led to a trip. Operators can see how the key pressures, temperatures, flows, and vibration behaved prior to the trip.

Sequence of Events Logging

Event sequence logging is a very useful tool in the operation of the machinery. It is mainly used to determine the reasons that cause trips and solve problems associated with startups. It is an important troubleshooting tool for the operators. It also has saved many problems due to the fact that in the past, operators would tend to start up units without fully understanding the cause of the trip. Data is logged at an interval of one millisecond.

CONDITION MONITORING OPERATING EXPERIENCE

The aforementioned system became operational in November 1985. All the features of the system were not available immediately, but trending of data was begun.

The specialist group onshore now have a very useful tool for evaluating the operation of the turbines and compressors that are monitored by the system. The ability to be able to observe the operation of the pipeline turbines, from 296 km away, has greatly increased the effectiveness of the specialist group. The quality of advice that can be given to the offshore operators and maintenance personnel is very different now, because previously the only communication was over the offshore telephone. The offshore personnel are improving their understanding of the operation of the turbines and compressors and are able to troubleshoot problems, with much greater confidence. Downtime is being reduced by quicker diagnosis of problems.

To date the system has proved most valuable in the troubleshooting mode. Vibration problems in particular have provided opportunities to use the system effectively to reduce downtime by speeding up investigation. Recently, one of the load compressor units was retrofitted with squeeze film bearings and tilt pad seals to overcome a persistent subsynchronous vibration problem. The vibration analysis capabilities of the DATM4 system is proving invaluable in monitoring the operation of the machine.

It is too early to say if the modification is a complete success, but at least it is possible to thoroughly document the effects of the modifications.

Because these units have been recently overhauled, there have been no dramatic savings from aerothermal analysis as yet, since the deterioration of the turbines and compressors is relatively slow, and longer term trends are required to detect the deterioration. However, small performance enhancements have been made by optimizing fuel nozzle flow patterns detected by exhaust temperature spread profiles.

The aerothermal part of the system is under continuous development and better ways of measuring performance by adding more instrumentation are being pursued.

The turbine operators are also learning the value of such routine tasks as changing air inlet filters and doing compressor washing at the optimum time, by seeing the instant increase in compressor efficiency. One interesting incident, which illustrates the usefulness of the system, occurred as follows. Shortly after the system was commissioned, the onshore specialist noticed that the compressor inlet temperature on one turbine was 10°C higher than the two adjacent turbines. Offshore maintenance were asked to investigate and check if there was a recirculation of the exhaust gases from the turbine or other turbines in the vicinity. They measured the temperature just in front of each of the air filter systems and reported no significant difference. After further investigation however, they found that the anti-icing ducting inside the intake was hot. The cause was a leaking valve in the anti-icing duct from the turbine exhaust. This represented quite a loss in efficiency and so fuel savings were made by fixing the valve.

By proper performance monitoring, the intervals between the various gas turbine inspections and overhauls have been increased amounting to large savings. The surge system has also enabled the units to be run with much less recycle flow leading to savings.

Gains in efficiency will often be made from simple maintenance tasks such as changing filters at the correct time, compressor washing, fixing leaking valves and cleaning fuel nozzles. One might assume that these tasks would be done anyway even without a condition monitoring system, but experience has shown that often these smaller tasks are put off to some future more convenient time. Highlighting loss in efficiency, by producing trend curves, can change this attitude.

The condition monitoring system itself has been available about 99 percent of the time in 1987 and with an improvement on the number expected in 1988.

Some observations and lessons learned are provided below:

- Inter-turbine temperature measurement on the gas turbine is a troublesome measurement from a sensor reliability point. Because of the short sensor life that has been experienced, a re-design is being considered for this probe.
- Users of sophisticated condition monitoring systems should expect initial onsite activities of software modification, database modification and system tuning. Time should be allocated for this (onsite). It is easy to underestimate the complexity of this task.

- The condition monitoring system highlights sensor failures. Work orders are written to correct these at the most convenient time.

- Maintainability of the data acquisition cabinets is a very important consideration. In retrospect, it would have been better to have a less tightly built unit which would help in maintenance.

- System documentation is a very important consideration. Improvements could be accomplished by the use of indexing of library software routines and by the use of detailed programmed interaction diagrams. More extensive help files would have been beneficial.

- User training should be provided at a place different than the installation site where operators can spend more time with the system without interruptions. This would require a simulation facility.

## CONCLUSIONS

Description and experiences with a comprehensive online condition monitoring system have been outlined, as applied to four gas turbine compressor trains. Computer based online condition monitoring systems will be the wave of the future on large critical machinery. These systems should provide the users and machinery engineers with greater insight into the working of the machine—both in terms of its thermodynamic performance, vibration behavior and performance of all auxiliary systems. This insight is invaluable when difficult value judgments are to be made relating to maintenance and availability of the machinery. This comprehensive system has been successfully integrated into the normal operation of an offshore platform.

## REFERENCES

1. Operating and Maintenance Practices for Heavy Industrial Gas Turbines on The Ekofisk to Emden Gas Pipeline; J. Cullen, CIMAC Proceedings, Warsaw, Poland, (June 1987).

## ACKNOWLEDGEMENT

The authors would like to thank the management and partners of the Phillips Petroleum group, Fina Exploration Norway, Inc., Norsk Agip A/S, Norsk Hydro a.s., Elf Aquitaine Norge A/S, Total Marine Norsk A/S, and Den Norske Stats Oljeselskap a.s. for their cooperation and approval of the publishing of this paper.