

ONLINE ULTRASONIC MONITORING OF BEARING WEAR

by

Jeffrey C. Chann

Sales Engineer

TecSonics, Incorporated

Twinsburg, Ohio



Jeffrey C. Chann is employed by TecSonics Inc., a subsidiary of J.W. Harley Inc., both of Twinsburg, Ohio. Mr. Chann is responsible for the nationwide sales of TecSonics equipment.

Before joining TecSonics, Mr. Chann spent five years with The Nash Engineering Company handling compressor and vacuum system sales.

Mr. Chann received his formal education in Chemical Engineering from Vil-

anova University.

ABSTRACT

Unpredicted bearing failures continue to plague industry with forced outages. As a result of these outages, many industries have attempted prevention by unnecessary inspections and premature bearing replacement. This work can be associated with significant incurred costs.

Bearing failures often occur after a lengthy process of wear, related to factors such as abrasion, corrosion, and erosion. Over the years, several techniques for indirectly measuring bearing condition have been developed and used. These techniques, however, provide imprecise measurements of bearing damage and wear rates. Until recently, the only direct measure of bearing condition was visual inspection and dimensional checks, both requiring shutdown and disassembly.

A bearing wear monitoring system has been developed to eliminate the interpretation of indirect symptoms and the need for bearing disassembly. The level of accuracy provides a diagnostic ability far more sensitive to wear than indirect methods such as vibration monitoring. In addition, the system provides data on the location and the extent of the problem.

Finally, the ultrasonic technique reduces inspection costs, and eliminates the risk of improper reassembly that may follow inspections.

INTRODUCTION

In theory, when a fluid-film bearing is properly designed, installed, and maintained, it should never wear. As with any mechanical component, however, fluid-film bearing bearings do experience operational difficulties. The potential causes of failure are many and varied. Proper performance of a bearing is critically dependent upon the proper functioning of other subsystems—for example, the lubricant, including its supply, return and conditioning. For the machine, these include rotor and shaft dynamics, and the mounting, housing, and pedestal foundations. Human interfacing is also a critical subsystem.

Without some form of monitoring, the first indication of a damaged bearing condition is usually a premature failure of the equipment. Over the years, several techniques for indirectly measuring bearing condition have been developed and used.

Some of these are lube oil analysis, oil temperature measurement, and monitoring of vibration levels. These technologies, however, indirectly evaluate the symptoms of a bearing problem, rather than directly, as it occurs.

An ultrasonic bearing wear monitoring system directly measures material loss from the bearing surface. During the process of wear, a bearing will eventually fail. The system can track this wear from inception through the point of bearing instability. There is a reduction in inspection costs and in the risk of improper reassembly. Diagnostic information of this kind eliminates guesswork in bearing conditions and allows maximum operational use of monitored bearings.

DESCRIPTION

The fundamental operating principle of the bearing wear monitor is a transducer which acts as an acoustic micrometer. The system times an acoustic signal as it passes through the transducer. The signal leaves a piezoelectric crystal, bounces off the transducer tip, and then passes back over the crystal. The amount of time that it takes for the sound to travel this path equates to distance. The transducers are installed flush with the bearing surface, exposing them to the same potentially harsh conditions as the bearing. If the bearing wears, so will the transducer tip, thus reducing the path length of the signal. This reduction means the signal returns to the crystal in a shorter amount of time. The measured time difference is converted to distance, thereby measuring the loss of material from the bearing surface. Measurements are independent of many operational parameters such as shaft speed, clearance, equipment vibration, and lube oil properties. In fact, measurements are possible at any operating point, even at rest.

In the ultrasonic system, there are only two main components required, the transducer and an electronic instrument. Transducers designed for the bearing wear monitoring system are specifically engineered for use in a variety of fluid-film bearings. Transducers are about the size of a pencil eraser and typically made of materials similar to the bearing (Figure 1). For example,

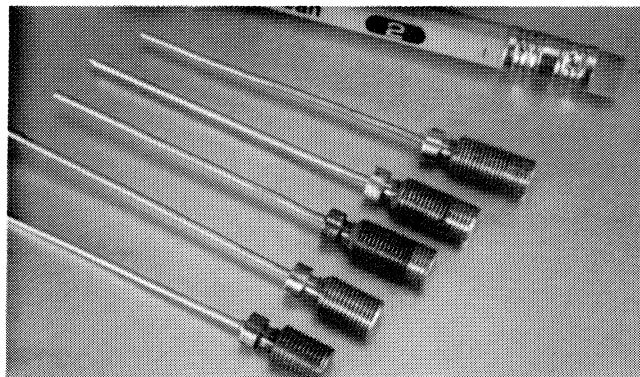

Figure 1. Transducers Are about the Size of a Pencil Eraser. Materials shown here, left to right, are steel, bronze, Babbitt/steel, #1 Babbitt/copper, and #2 Babbitt/copper.

steel, copper or Babbitt tipped transducers are used in bearings of that type. Transducers, each containing a piezoelectric crystal are installed in a bearing at known or anticipated wear areas. The transducers can be installed in new bearings or in bearings as they are reconditioned (as illustrated in Figures 2, 3, 4, 5, 6, 7, 8). When installed, the transducers become an integral part of the bearing surface so the transducer wears at the same rate as the bearing.

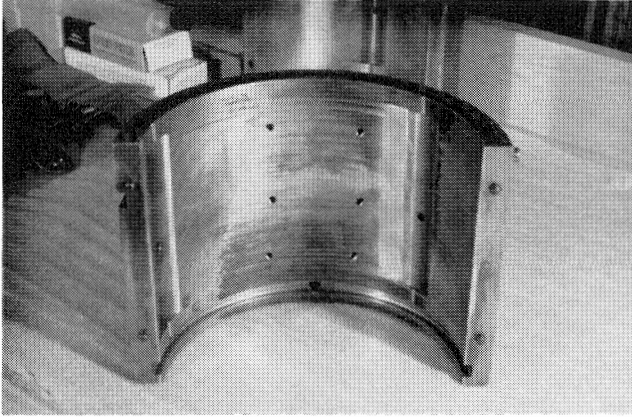

Figure 2. The Bottom Half of an Elliptical Journal Bearing Showing Transducer Locations in the Wear Area.

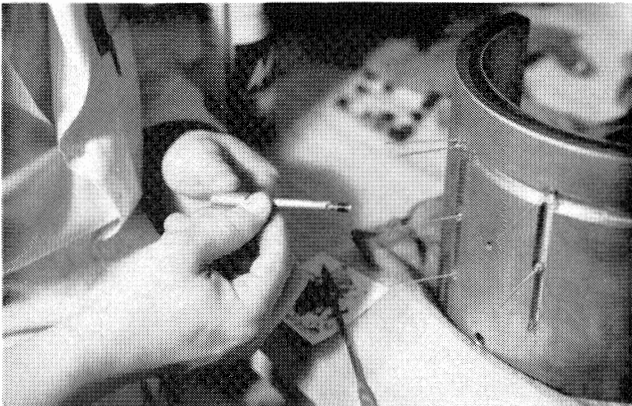

Figure 3. Transducers Are Installed through the Back of the Bearing.

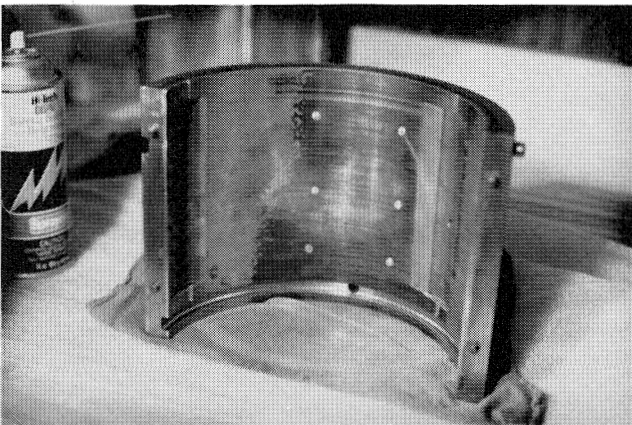

Figure 4. The Bearing with Transducers Installed.

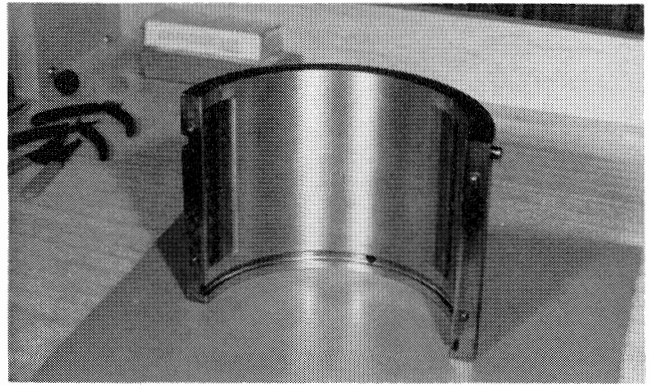

Figure 5. The Finished Bearing, Ready to be Installed in the Machine.

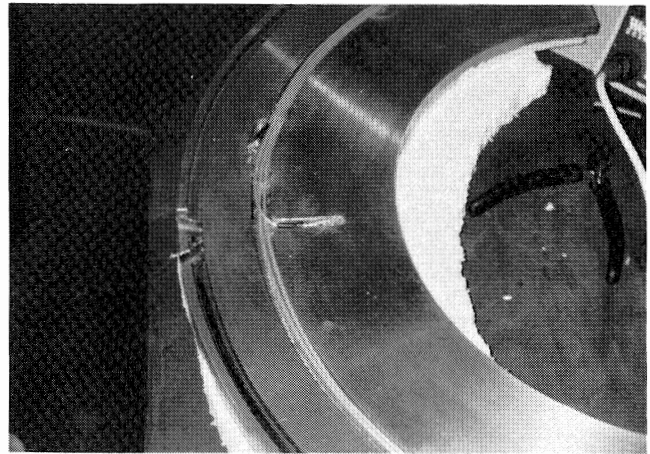

Figure 6. A Tapered-Land Thrust Bearing Showing Sensor Cables in the Channel.

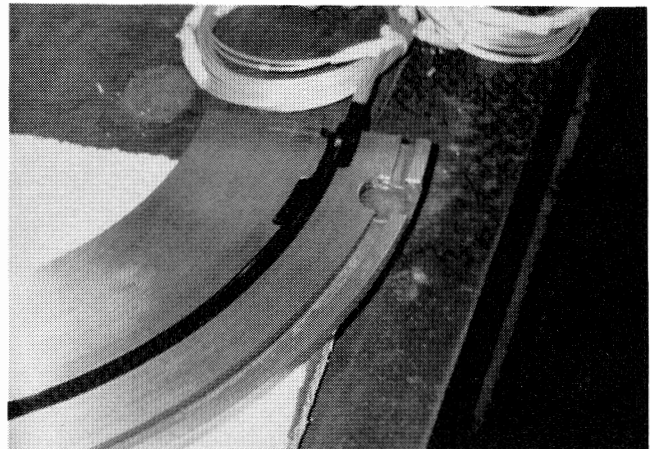

Figure 7. The Cable Channels Set in Epoxy.

As illustrated in Figures 9 through 16, instrumentation included with the system sends a pulse to a piezoelectric crystal mounted in the transducer. This crystal, in turn, emits a sound wave that travels to the face of the transducer and is reflected back. The returning wave reexcites the crystal, which sends a signal back to the electronic instrument. This instrument iden-

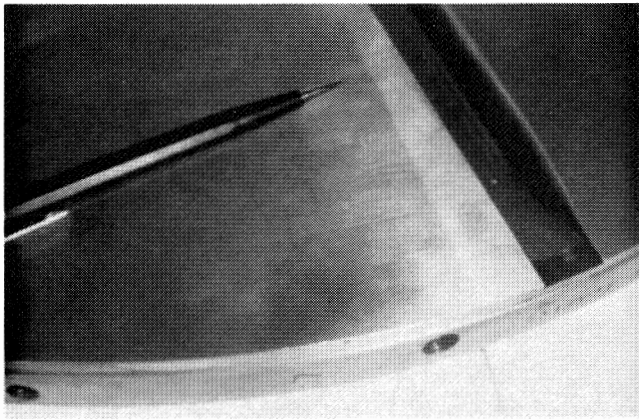

Figure 8. The Finished Bearing Surface after Transducers Are Installed. The transducer tip is barely visible; the transducer in the taper is within the drawn circle.

tifies and qualifies the signal, measuring the elapsed time between signal emission and receipt. The qualification process prevents false readings from other sources. The measured time difference translates accurately into distance.

Distance measurements are read with an electronic instrument. A block diagram of the processing is shown (Figure 17). A

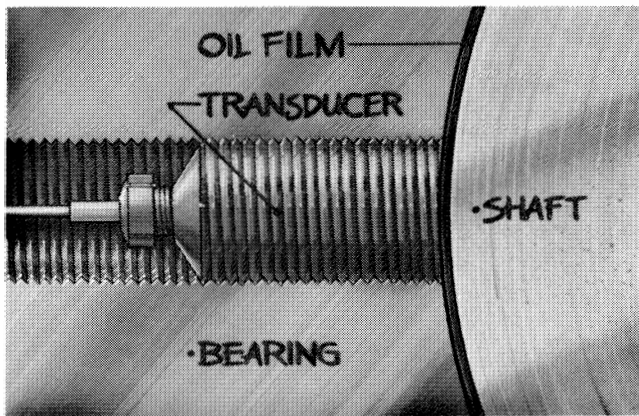

Figure 9. The Transducer Is Mounted in the Bearing in Such a Way That It Becomes an Integral Part of the Bearing.

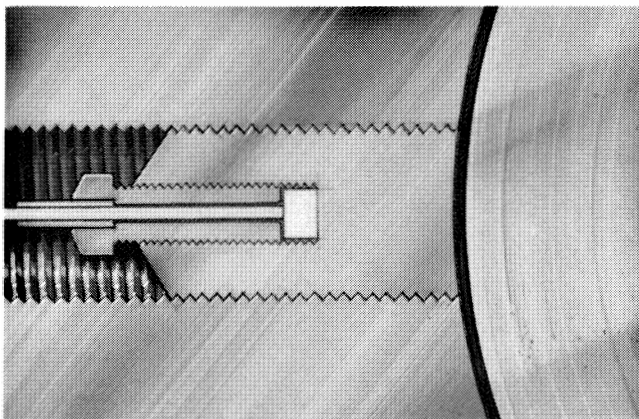

Figure 10. A Piezoelectric Crystal is Located within the Transducer.

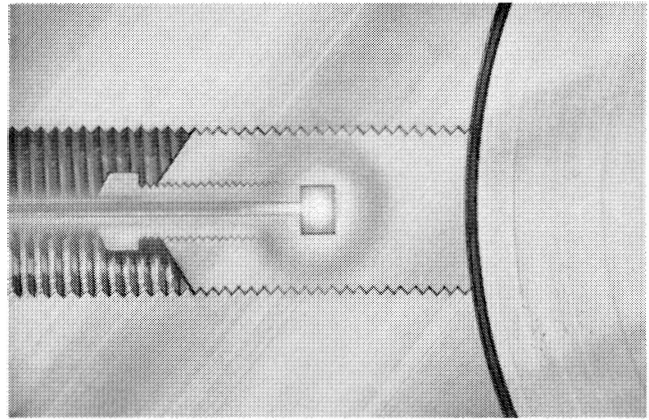

Figure 11. The Crystal Emits a High Frequency Sound Wave When It Is Excited by a Signal from the Monitoring System.

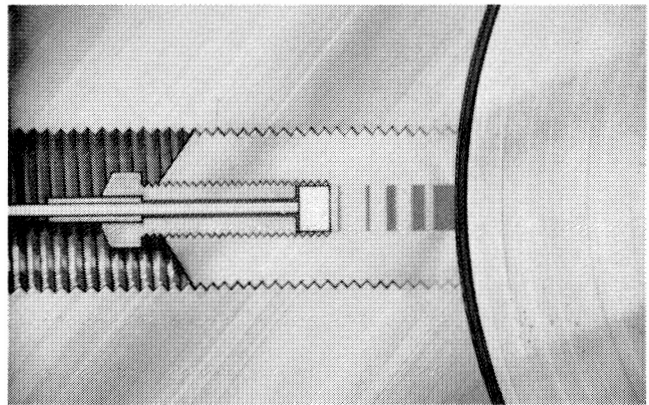

Figure 12. The Signal Travels to the Face of the Transducer and "Bounces" or "Echoes" Back.

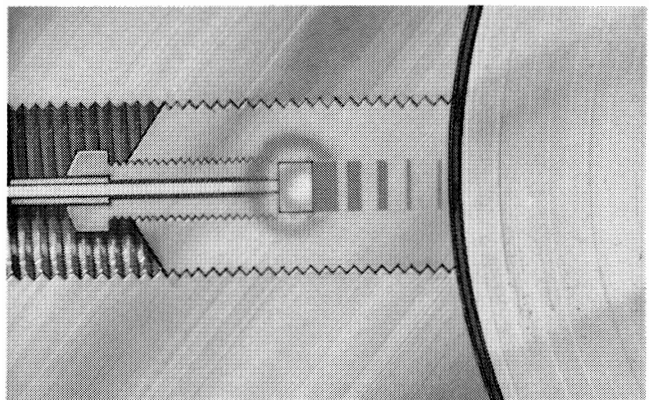

Figure 13. The Echo of the Signal Re-Excites the crystal.

readout for each installed transducer is obtained. With a portable instrument, each transducer channel is keyed in manually. With a continuous, online system, sampling is performed as directed by the host computer. The continuous, online network system is shown in Figure 18, in which one of the multiple sensor loops is illustrated. The sampling and processing of data for each transducer is shown. The main electronics handle the processing of all channels and interface with the host computer. Each pulser/receiver station (only one shown) handles each remote

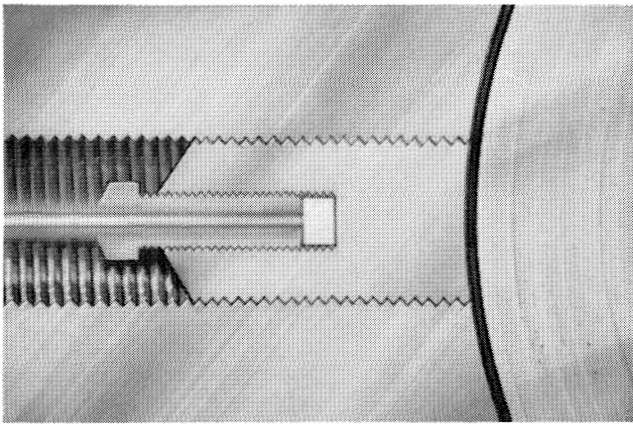

Figure 14. A Signal Then Travels from the Excited Crystal Back to the Electronics System.

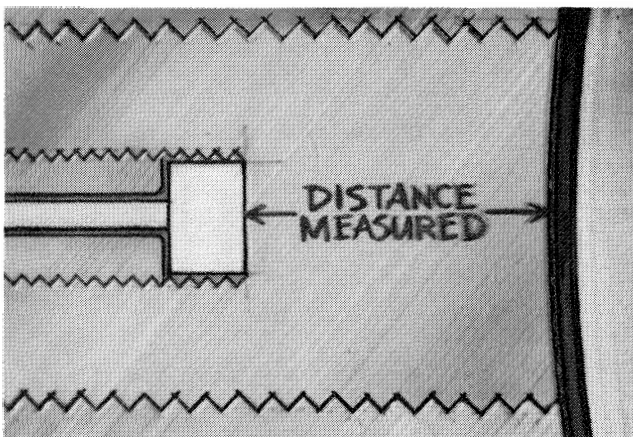

Figure 15. The Electronics System Measures the Time from Signal Emission to Echo Receipt.

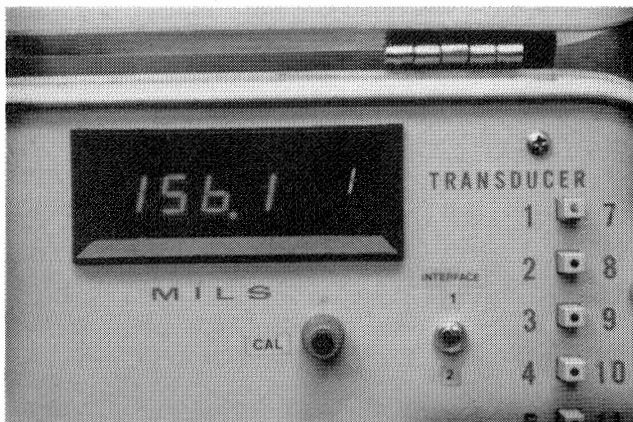

Figure 16. The Time Difference Translates Accurately into Distance. The readout is mils.

bearing location. The readout for either system is in mils (thousandths of an inch) with an accuracy of ± 0.0002 in. Comparing a current reading with a previous reading gives an indication of bearing wear. Trending of these measurements is a convenient means to determine the rate of change in a bearing (Figure 19). The combination of multiple wear data points provides data

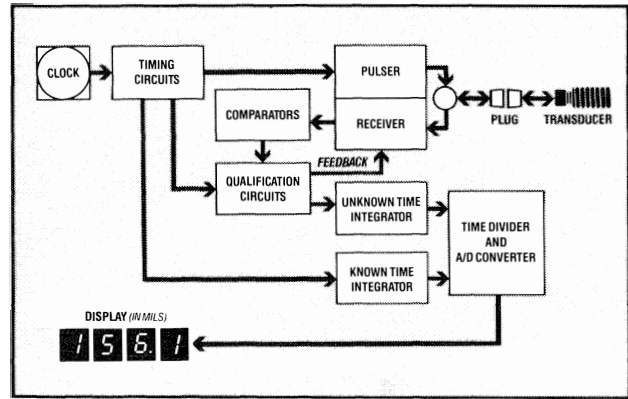

Figure 17. Bearing Wear Monitor Signal Processor Block Diagram. 1. The clock and timing circuits generate two system control command, (a) an accurate reference pulse for the known time integrator, and (b) a high frequency trigger signal for the pulser. 2. The pulser fires a voltage pulse to activate the piezoelectric crystal in the transducer. 3. The transducer crystal converts the pulse to an ultrasonic signal, which travels to the face of the transducer and rebounds. When the return signal strikes the crystal, a small characteristic electrical wave is emitted. 4. The receiver separates the characteristic wave and converts it from an analog to digital signal for processing. 5. The digital signal is then sent to the qualification circuit. 6. The qualification circuit determines that a proper signal has been received, locks on to it, and stops the unknown time integrator. This generates a value for the unknown time signal. 7. The unknown time integrator converts the digital unknown time value to a voltage proportional to microseconds. The known time integrator converts the accurate one-microsecond pulse to a reference voltage. 8. The final process compares the unknown time integrator voltage to the one-microsecond reference voltage, applies a calibration constant, and translates it to a digital number. 9. This digital number is displayed as a measurement in units of thousandths of an inch.

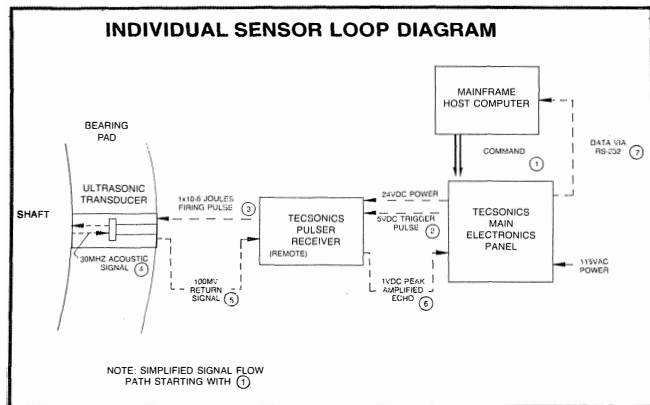

Figure 18. Sensor Loop Diagram Showing Interface with a Host Computer.

on the extent of wear, as well as the wear pattern in the bearing (Figure 20).

Given such information, users can estimate the remaining safe operating life of bearings. Maintenance can be scheduled based on actual bearing condition (Figure 21). In addition, by trending wear against various operating conditions, an operator

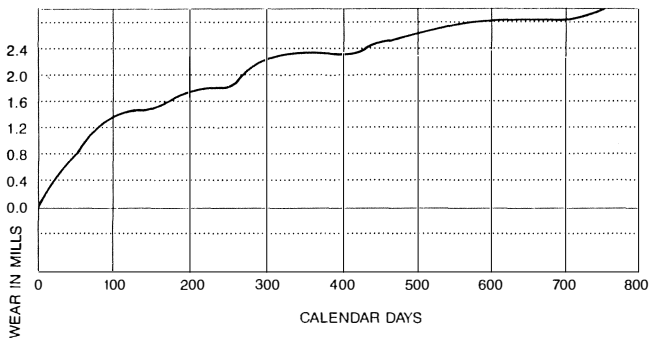

Figure 19. Two Years of Ultrasonic Wear Measurements from a Thrust Bearing in a Steam Turbine.

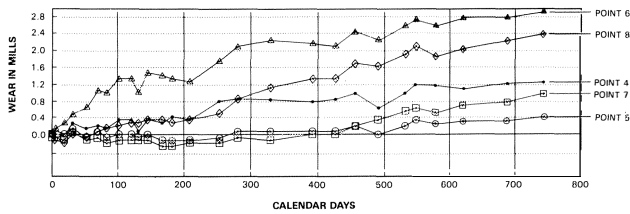

Figure 20. Multiple Wear Data Points on a Thrust Bearing.

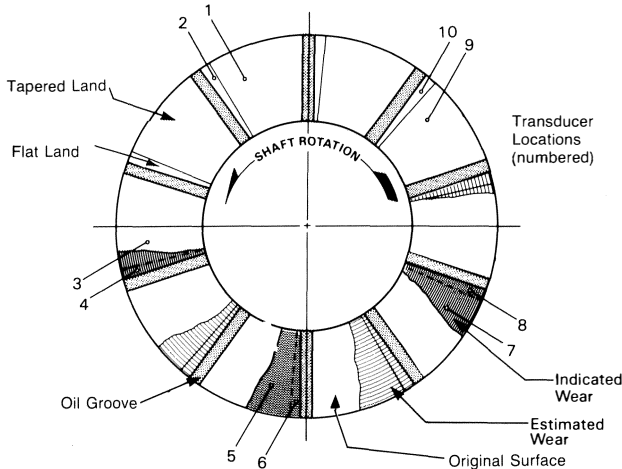

Figure 21. Indicated Bearing Wear after 745 Days of Operation.

may identify conditions that cause accelerated wear. Then the user can develop strategies to minimize those operating conditions.

LABORATORY TESTS FOR ACCURACY

Laboratory tests were conducted to verify the ability of the transducer to accurately measure surface material loss. A flat surface thrust bearing was used as the fixture, into which several transducers were installed. To simulate bearing wear, the face of the block was carefully machined with a milling machine. As the surface material was removed, the thickness of the thrust plate was measured with a micrometer at each transducer location. Differences in these measurements reflect how much material was removed from the surface. The ultrasonic transducer data gathered from each point were compared to these physical measurements. The results are shown in Table 1. Three types of transducers were used for the test: one solid bronze, and two

Babbitt tipped. The electronic instrument used at that time, was calibrated for bronze. Results of the bronze transducer readings in comparison to measurements by the micrometer were accurate and agreed satisfactorily. As expected, however, a variance was observed with readings taken from Babbitt tipped transducers. As shown in Figure 22, this variance is linear, and can be accounted for by applying a numerical constant to the data. When a factor of 0.7 is applied to the copper/Babbitt data, it matches the bronze data. This variance is identified as a result of the change in the speed of sound in different metals. With the electronics calibrated for bronze material, the numerical factor corrects the data for the other material. The test results were found to be accurate, and the ultrasonic transducer system was verified as an accurate method of measuring bearing wear.

Table 1. Results from Laboratory Testing for System Verification.

Measurements taken by various transducers of surface material removed by a milling machine.			
Micrometer Readings Inches	Transducer Results, Inches		
	Bronze	Copper/Babbitt	Copper/Babbitt
0.001	0.0011	0.0013	0.0016
0.002	0.0022	0.0031	0.0029
0.003	0.0029	0.0038	0.0041
0.004	0.0040	0.0055	0.0053
0.005	0.0048	0.0063	0.0067
0.006	0.0059	0.0079	0.0079
0.007	0.0066	0.0088	0.0092

Results of transducer measurements showing a deviation due to transducer materials. Electronics calibrated for bronze only. Experiment date 7-1-87.

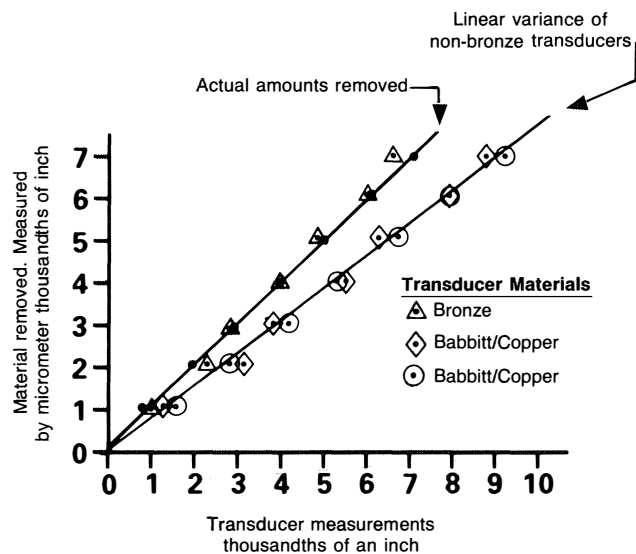

Figure 22. Laboratory Test Results Showing the Accuracy of the Ultrasonic Method.

COMPENSATION FOR THERMAL EFFECTS

Changes in bearing temperature cause expansion or contraction of the bearing material. Additionally, temperature affects the speed of sound in metals. These variables have a dramatic effect on the results obtained using ultrasonics. Temperature re-

ferencing technology was developed, compensating for the temperature variables. A transducer is embedded in the bearing, very near, but not through the bearing surface. The transducer does not penetrate the surface, therefore it will not wear. In this manner, this nonwearing transducer measures itself. Any expansion or contraction relates to temperature. The reference transducer measures the thermal effects, allowing adjustment of the electronic instrument.

Due to different bearing designs, a single reference transducer may not provide enough localized information for accurate compensation. To eliminate the addition of multiple reference transducers, localized compensation was developed. Tilting pad bearings provided a special challenge for temperature compensation. Since each pad is free to react to the developed hydrodynamic pressure distribution, the load zone and temperature profiles will vary (Figure 23). The temperature profiles within each pad may be quite different and may change during operation. A reference transducer in each pad does not adequately measure this profile. Multiple references in each pad are not economically feasible. Extensive testing on a turbine at Kingsbury, Incorporated, was initiated to address this problem.

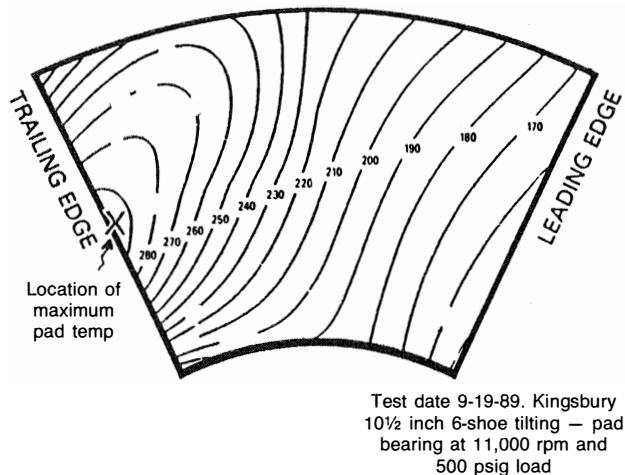

Figure 23. Isotherms in a Tilting-Pad Thrust Bearing Pad.

Temperature compensation was desired at each wear measuring transducer. Self-referencing technology was developed for this purpose. This technology allows the electronic instrument to sense thermal changes within each transducer, correct for this change, and recalibrate the transducer for wear measurement. To do this, an internal signal reflecting point is built in to the transducer, below the wear surface. This internal reference point reflects part of the ultrasonic signal back to the crystal in the same manner as the wear surface. The scope trace of a standard transducer is illustrated in Figure 24, and the same is shown in Figure 25 transducer with the self-referencing feature. The electronic instrument reads the internal reference point, which is then compared to a known baseline value. The reference point is internal and is not exposed to wear. If temperature causes an expansion or contraction of the metal transducer, the electronics will measure it. With each transducer being self-referencing, the temperature variable can be eliminated for any transducer in the bearing. A Kingsbury thrust pad, shown in Figure 26, is fitted with the self-referencing transducers for testing. Testing of this system, at the Kingsbury test facility, revealed consistent readings with improved accuracies as well as confirming the temperature compensating feature.

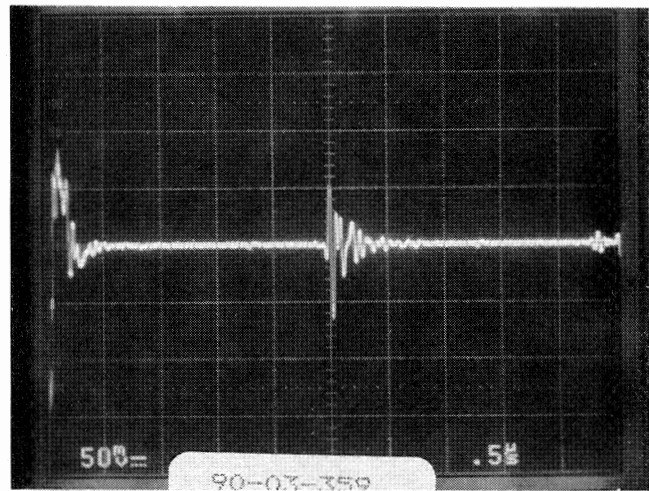

Figure 24. Oscilloscope Trace of a Standard Transducer. The firing pulse is shown to the far left. The return echo, from the transducer tip, is shown in the middle of the trace.

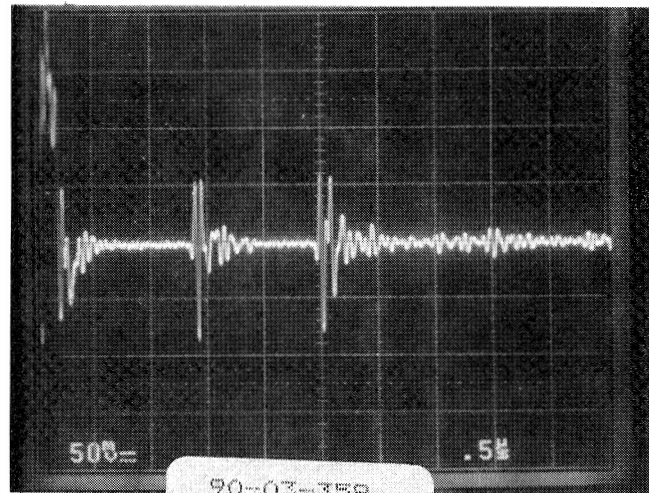

Figure 25. Oscilloscope Trace of a Self-Referencing Transducer. From left to right, are the firing pulse, self-referencing echo, and the transducer tip echo.

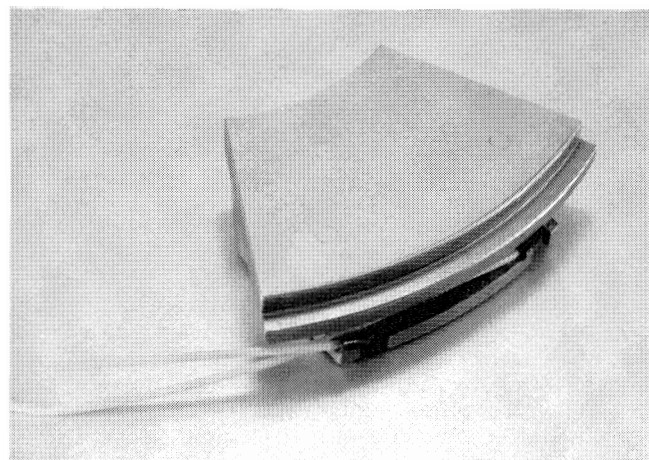

Figure 26. Self-Referencing Transducers Installed in a Self-Aligning Thrust Pad.

CURRENT APPLICATIONS AND EXPERIENCE

In 1985, the ultrasonic bearing wear measurement system was introduced to the electric utility industry for transformer oil circulation pumps. These pumps are typically one to ten horsepower, wet-end motor design that can run continuously for years before scheduled maintenance. Disassembly of these pumps for bearing inspection is expensive, because the transformer oil requires retreatment after the system is disassembled. By eliminating bearing inspection, this application of the ultrasonic bearing wear monitoring system has been beneficial to the utility industry, with more than 1500 installations.

An installation exists in a 250 MW steam generator turbine drive located at Cleveland Electric Illuminating's Eastlake Station. Eight main journal bearings support the rotating elements of the turbine. One thrust assembly absorbs the axial forces. One of the thrust bearings is a ten segment tapered-land design with Babbitt material. This bearing, (Figure 27) is shown as found during a three year inspection. The thrust bearing was worn to an estimated 40 percent of the design load capacity. Operating records of axial position and bearing temperatures did not reveal any significant shift or bearing overheating. As shown in Figure 28, transducers were installed in five out of the ten land areas. In these instrumented sections, one transducer was placed in the flat land and one in the tapered land. In reference to Figure 29, the transducer in the flat land is more likely to show wear than the transducer in the taper. Monthly wear data recorded for the first 745 days of operation is graphically represented in Figure 30.

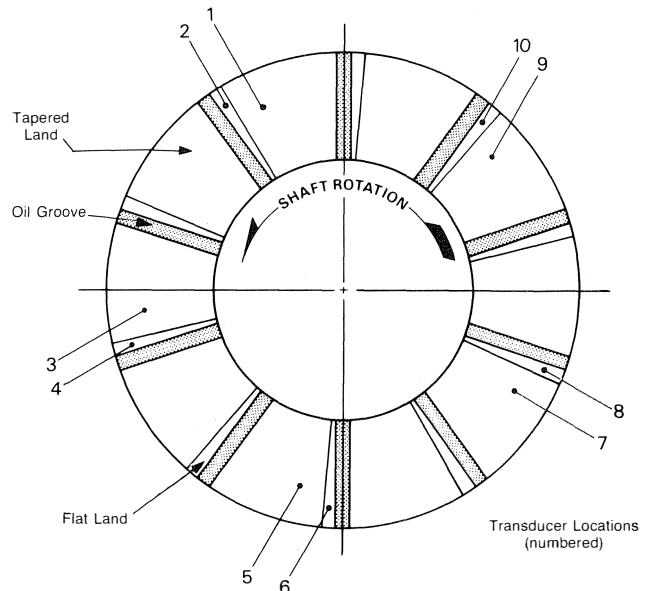

Figure 28. Transducer Locations on a Tapered-Land Thrust Bearing.

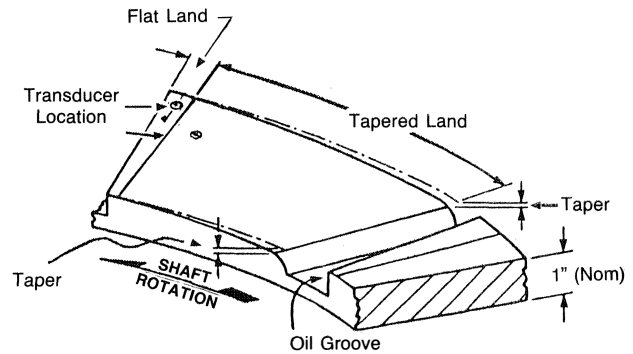

Figure 29. Developed View of a Tapered-Land Segment Showing Transducer Layout.

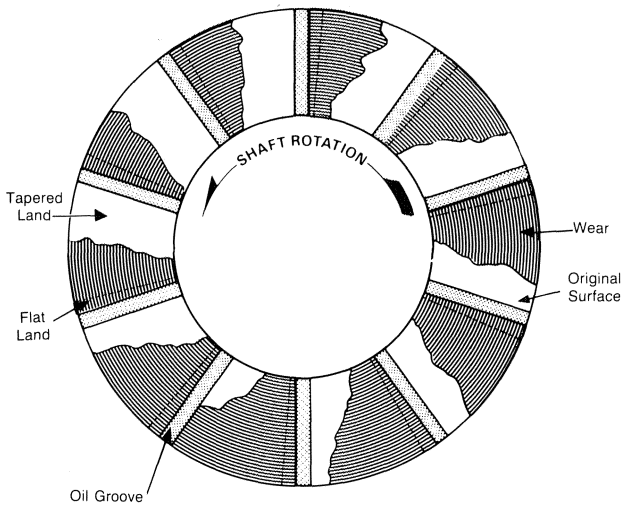

Figure 27. Wear Patterns on a Tapered-Land Thrust Bearing, after Three Years of Operation, as Shown by Physical Inspection.

Through a project with Philadelphia Electric Company and the Electric Power Research Institute (EPRI), a 350 MW steam generator turbine is fitted with the bearing wear monitoring system. Two tilt-pad radial bearings and two thrust bearings are equipped with transducers. The system has been operational for over 20 months. Data is obtained with the portable electronic instrument on a semimonthly basis. In January 1989, an upset to the turbine occurred. After this incident, additional readings were taken and compared to earlier values. Insignificant wear had occurred due to this incident, as shown in Figure 31. This data supported other turbine diagnostics verifying that the bearings did not suffer damage as a result of the upset.

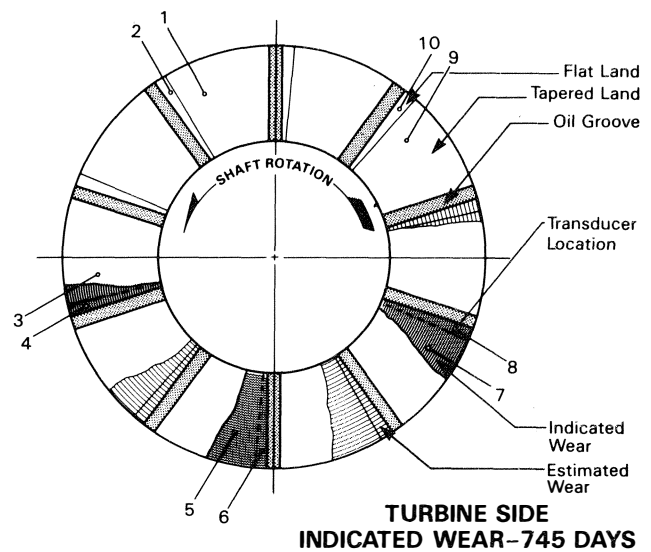

Figure 30. Indicated Wear Patterns Based on Ultrasonic Measurement Data, 745 Days of Operation.

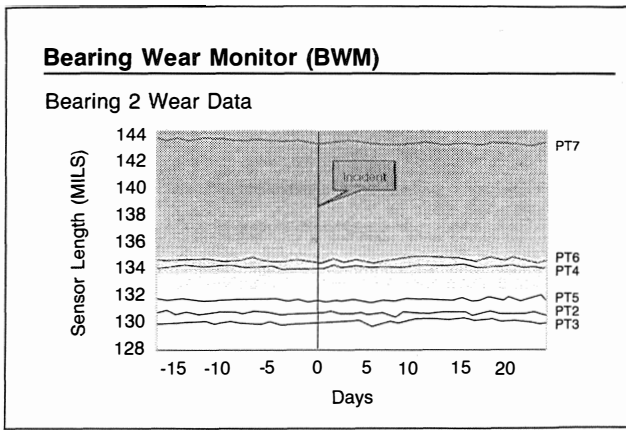

Figure 31. Wear Data Records During a Heavy Vibration Incident Showing No Wear Damage to the Bearing.

In February 1990, the unit was shut down for maintenance and the monitored bearings were inspected. The data collected for 20 months was confirmed by the physical inspection of the bearings. Of the four bearings monitored, one bearing showed extensive wear patterns. This was the generator end thrust bearing. The other thrust bearing and the two journal bearings did not have significant wear. The historical data and a photograph of the generator end thrust bearing are shown in Figures 32 and 33. This information proved useful in the evaluation of bearing condition while operating the turbine. The physical inspection confirms the transducer data and verifies the predictive maintenance capabilities of the ultrasonic bearing wear monitor system.

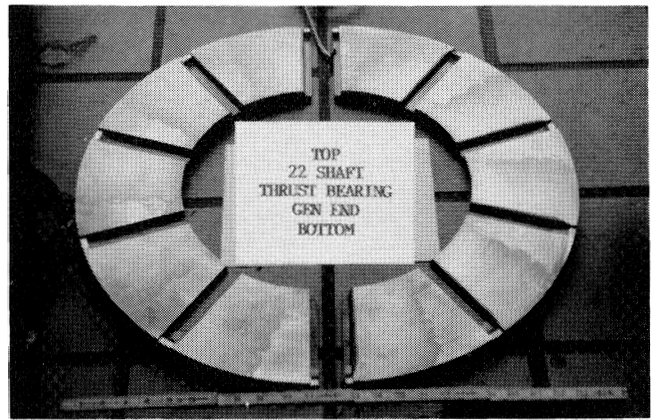

Figure 33. Physical Damage to a Bearing from a 20-Month Operation Confirming the Ultrasonic Wear Monitor Data.

SUMMARY

The bearing wear monitoring system has proven cost effective by eliminating equipment disassembly for bearing inspection. This technology provides more online diagnostic information than previously possible. It eliminates the guesswork of bearing condition. This is accomplished through direct, continuous, accurate measurement of material loss rather than monitoring some other phenomenon of bearing distress. Trending wear patterns with system or process upsets provides additional diagnostic information. This information allows the maximum operational use of bearings. The user now can predict bearing replacements, minimize unscheduled inspections, and reduce equipment failure risk.

BIBLIOGRAPHY

- Haramis, G. ., et al., "Condition Monitoring of Operating Fluid Film Bearings With Ultrasonic Transducers," Mechanical Failures Prevention Group, Office of Naval Research, Symposium (April 1990).
- Electric Power Research Institute, "On-Line Ultrasonic Monitoring of Bearing Wear," Technology Review (1989).

ACKNOWLEDGEMENTS

The development and application of TecSonics technology is the result of a team effort. Contributions to the effort have been added by: Dov Hazony, Case Western Reserve University; Wayne Karberg, Centerior Energy; John McElroy, Philadelphia Electric Company; Richard Colsher, Electric Power Research Institute; Steve DeCrow; Renewal Parts Maintenance, Incorporated; Richard Berris; Berris Electronics; and Frederick Wiesinger, Kingsbury, Incorporated.

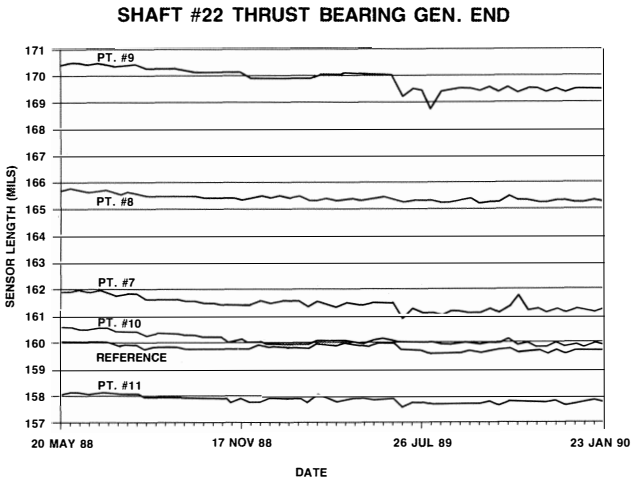

Figure 32. Data Trends Showing Bearing Condition During a 20-Month Operation. Data represent only a partial sample of collected information.