

# USING A DAMPER SEAL TO ELIMINATE SUBSYNCHRONOUS VIBRATIONS IN THREE BACK-TO-BACK COMPRESSORS

by

**Robert L. Richards**

Project Manager

Amoco Torlon Products

Atlanta, Georgia

**John M. Vance**

Professor, Department of Mechanical Engineering

Texas A&M University

College Station, Texas

**Donald J. Paquette**

Project Engineering Manager

and

**Fouad Y. Zeidan**

KMC, Inc.

West Greenwich, Rhode Island



*Robert L. (Bob) Richards is a Project Manager with Amoco Chemicals Polymers Business Group in Atlanta, Georgia. He started his career working for the Chevron Refinery in El Paso, Texas while attending The University of Texas. He transferred to Aramco in Abqaiq, Saudi Arabia as a Maintenance Supervisor and Rotating Equipment Specialist where he worked for 11 years. He joined Amoco Chemicals at their Texas City Plant in 1979 as a Maintenance Supervisor of Critical Equipment. He was transferred to his present assignment in Atlanta to assist with the development of the Amotech process in 1990. His job functions involve the design, application and installation of parts in rotating equipment that improve efficiency and reliability. He presently holds three U.S. patents.*

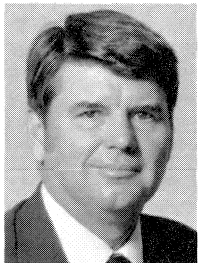

*John M. Vance is a Professor of Mechanical Engineering at Texas A&M University. He received his B.S.M.E. (1960), M.S.M.E. (1964), and Ph.D. (1967) degrees from the University of Texas. Prior to joining Texas A&M in 1978, Dr. Vance held full time engineering positions at Armco Steel, Texaco Research, and Tracor, Inc., and developed a Rotordynamics Laboratory at the University of Florida. Dr. Vance is currently conducting research on rotordynamics, bearing dampers, and seals in the Rotordynamics laboratory at Texas A&M. He has published a book entitled Rotordynamics of Turbomachinery (John Wiley, 1988) and more than 50 technical articles and reports on rotordynamic instability, squeeze film bearing dampers, vibration isolators, and related subjects. He is an active consultant to industry and government and has held 11 summer appointments at Pratt and Whitney Aircraft, USARTL (Helicopter Propulsion Lab, Ft. Eustis), Southwest Research Institute, Shell Development Co., and the Balcones Center for Electromechan-*

*ics. He organized the annual short course for industry at Texas A&M on "Rotordynamics of Turbomachinery" and co-organized the biennial "Workshop on Rotordynamics Instability Problems in High Performance Turbomachinery," and has served on the Advisory Committee for the Turbomachinery Symposium since 1983. Dr. Vance is an inventor on several patents relating to rotating machinery and vibration control.*

*Dr. Vance was named the Dresser Industries Associate Professor at Texas A&M in 1979-80 and was Associate Head of the Department of Mechanical Engineering in 1980-81. He was named a Halliburton Professor for 1986-87 and a TEES Research Fellow in 1991-1992. He is a member of ASME and ASEE, and he is a registered Professional Engineer in the State of Texas.*



*Donald J. Paquette is Project Engineering Manager at KMC Inc. in West Greenwich, Rhode Island. Mr. Paquette has been with KMC since 1988 where he is actively involved in the design, finite element analysis, rotordynamic analysis, testing, and development of deflection pad and other high performance journal and thrust bearings. He is also involved in the development of efficient analysis procedures for high performance journal and thrust bearings.*

*Mr. Paquette received his B.S. degree (Fluid and Thermal Engineering) from Case Western Reserve University (1988). He is currently pursuing an M.S.M.E. degree at Worcester Polytechnic Institute. He has written several technical papers for reviewed journals and is a member of ASME.*

## ABSTRACT

A new type of labyrinth seal that reduces cross coupled rotor forces and produces a remarkable amount of damping has been invented at Texas A&M University. Laboratory tests have shown

complete elimination of critical speeds under some conditions and orders of magnitude more damping than conventional labyrinth seals. The new seal acts as a damper by dynamic variations of gas pressure in large pockets around the shaft that always oppose the rotor vibratory motion. The pocket walls also serve to block the gas swirl that produces the cross coupling in conventional seals. The background is described of the invention of the new seal along with two case histories of its design, installation, and use for solving subsynchronous vibration problems in back-to-back centrifugal compressors. In Case 1, the seal construction is of conventional metallic materials, while in Case 2, the seal is made of an amorphous copolymer with engineered properties to produce a better tolerance of shaft rubs during surge events. The subsynchronous vibration problems were solved in both cases by retrofitting the new type of seal. In Case 2, a small number of seal blades was used in order to produce large pockets with a very large damping value, and the use of engineered plastic as a seal material allowed the machine to tolerate surge and remain stable, which had not been possible with conventional labyrinth seals.

## BACKGROUND

Since about 1980, much of the research in the Turbomachinery Laboratory has been directed toward solving vibration problems in high performance turbomachines through the use of bearing dampers and seals. Dara Childs, the current Director of the Laboratory, showed in 1978 that seals were the major source of such problems in the Space Shuttle Main Engine Turbopumps. When he came to Texas A&M University, Dr. Childs set up a large scale high speed seal test facility for measuring rotordynamic coefficients and leakage of gas seals. Meanwhile, the second and fourth authors of this paper (Vance and Zeidan) researched the design and operation of squeeze film bearing dampers, mainly for aircraft engines, but later used in high performance industrial centrifugal compressors. Although this research resulted in better damper designs, it became obvious that the bearings in many turbomachines are not well located for the purpose of damping rotor vibration. In fact, bearings are often located near the nodes of the mode shapes to be damped. Seals, on the other hand, are often located near the antinodes, where damping is the most effective. It became clear that a gas seal with high damping and no cross coupling would be the antivibration device of choice for many turbomachines, especially back-to-back compressors with center labyrinth seals.

Some years earlier, Alford [1] suggested by mathematical analysis that labyrinth seals could have very large damping, either positive or negative depending on whether the seal blade/shaft clearances are increasing or decreasing in the direction of leakage flow. Murphy and Vance [2] extended Alford's analysis to include more blades in the model and to allow the possibility of unchoked flow through the seal. The predictions of very high direct damping were confirmed in their analysis as well. However, 10 years of testing labyrinth seals in the Turbomachinery Laboratory (see for example, Vance, et al. [3]) have shown that the predictions of Alford [1], and of Murphy and Vance [2], were incorrect. That is, conventional labyrinth seals actually have very small direct damping, regardless of the shaft/blade clearances, converging or diverging. Furthermore, conventional labyrinth seals do have significant cross coupled stiffness coefficients which are destabilizing to forward rotor whirl. The cross coupling is produced by swirl of the gas around the annular cavities between the blades of the seal. The unobstructed circumferential flow is also the factor which invalidates Alford's theory for direct damping.

Around 1990, the second author finally came to realize that Alford's predictions of high direct damping with diverging

clearances could be made valid by simply installing walls in the annular cavities of a seal to separate them into a number of pockets around the circumference. In 1991, this idea was brought to a prototype test by Richard Shultz [4]. A free vibration test result is shown in Figure 1 of the first prototype compared with a conventional labyrinth seal. Subsequent improvements in the design have resulted in the ability to completely suppress a critical speed in a laboratory test rotor as shown in Figure 2.

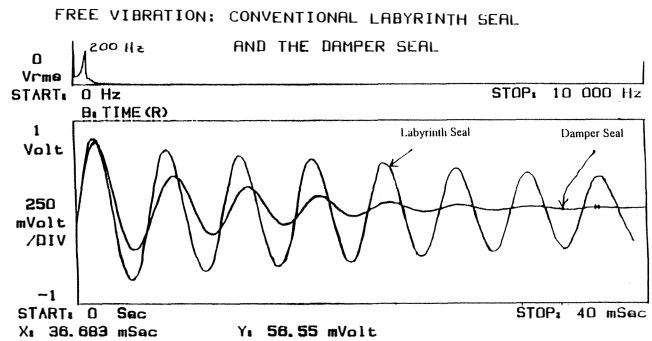

Figure 1. Free Vibration Test of Prototype Seal.

## Horizontal Coastdown Curves ( Pressure = 45.0 psia )

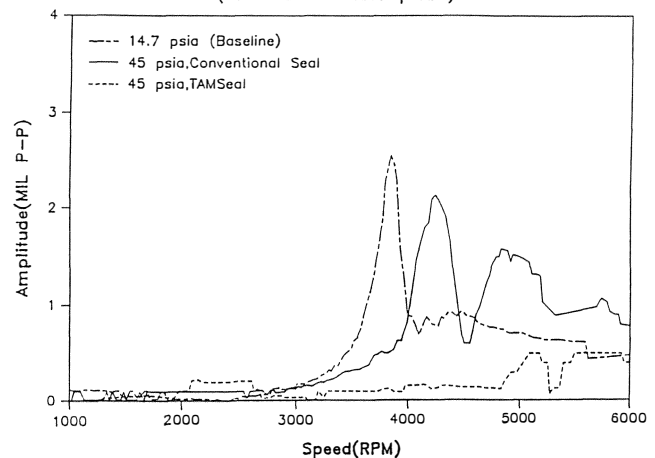

Figure 2. Laboratory Rotor Response to Imbalance.

After seeing the laboratory test results of the pocket damper seal at a meeting of the Turbomachinery Research Consortium, John Platt of Amoco Research suggested the possibility of a field test in a centrifugal compressor that had a history of subsynchronous vibration problems [5]. The second author computed damping coefficients for several versions of a new center seal of the new design that could be retrofitted to the compressor and also conducted a rotordynamic stability analysis of the expected results. The unstable mode of the unmodified machine is as predicted by the computer code with  $-0.06$  logarithmic decrement (Figure 3). The same mode is predicted in Figure 4 to be very stable with a four bladed pocket damper seal producing a positive  $3.1$  logarithmic decrement. The leakage and the damping are predicted to vary with the number of blades in the damper seal as shown in Figures 5 and 6. Since three identical sister compressors had proven difficult to stabilize in the past, four blades were chosen (Figure 6) as an optimum to achieve acceptable leakage with very high damping. The actual test results of this retrofit and the details of the seal design are presented under Case II below.

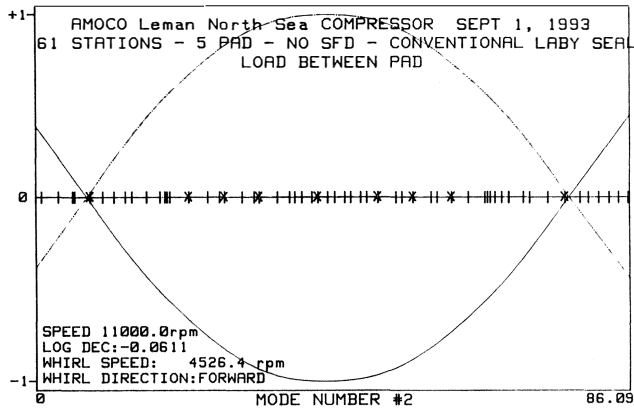

Figure 3. Unstable Whirl Mode of Unmodified Compressor—Case 2.

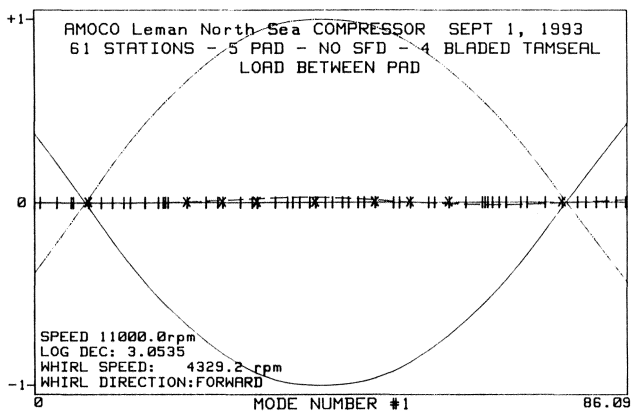

Figure 4. Stabilized Whirl Mode of Compressor With Pocket Damper Seal—Case 2.

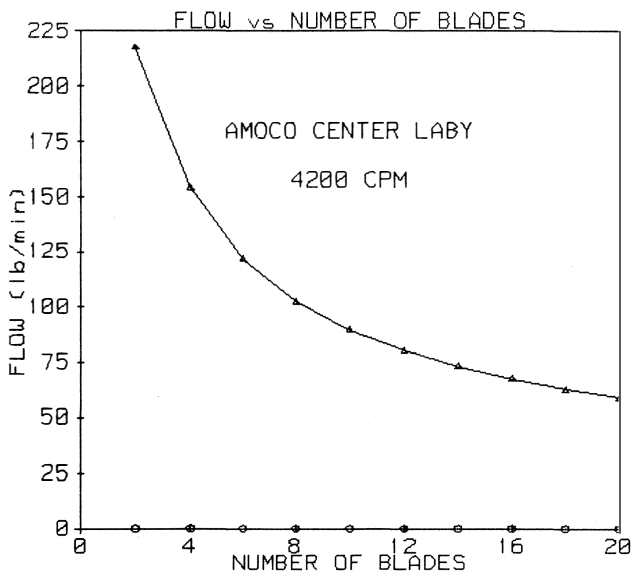

Figure 5. Pocket Damper Seal Leakage vs Number of Blades—Case 2.

Texas A&M University has patents pending on the pocket damper seal. The technology was licensed to KMC, Inc., who

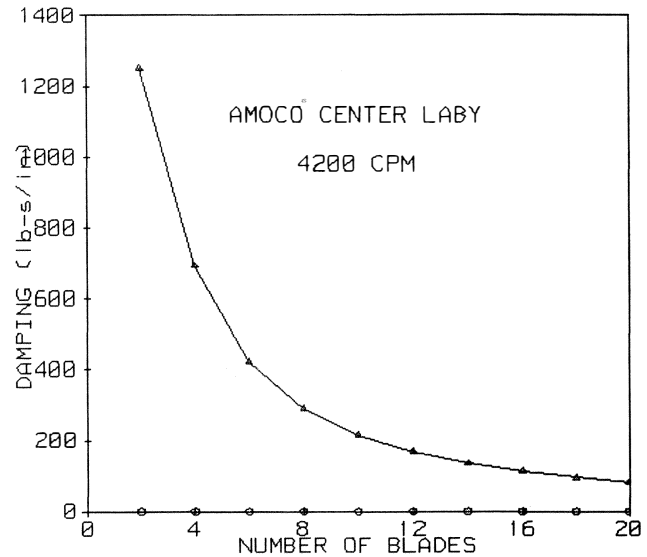

Figure 6. Pocket Damper Seal Damping vs Number of Blades.

designed the applications of Case 1 and performed the rotordynamic analysis with the seal coefficients supplied by the second author.

Conventional labyrinth seals continue to be a source of aerodynamic excitation in high pressure compressors. The theory and corresponding computer programs available to model and predict the dynamic coefficients for labyrinth seals operating at high pressures are still inadequate as demonstrated by the cases presented here. Honeycomb seals have replaced labyrinth seals where they have been shown to provide better damping and eliminate aerodynamic cross coupling (Zeidan [6]). In Case 1 (to be described later) however, the delivery schedule for the compressors was not compatible with the relatively long lead time required for the manufacture of a replacement honeycomb seal. Furthermore, the rotordynamically desirable honeycomb configuration consists of a smooth rotor and a honeycomb stator. This would require machining the steps off of the rotating shaft to provide a smooth rotor. This in turn would mean a repeat of the high speed balancing operation on a total of eight rotors. These limitations, which are not uncommon, dictate alternative solutions, which can be accomplished in a relatively short time, and without any change to the rotating components on the shaft.

### SUMMARY OF THE TWO CASES

In the cases described in detail below, subsynchronous vibrations were experienced on three different high pressure back-to-back compressors. The first case involves a compressor train with a low pressure compressor (LPC) and a high pressure compressor (HPC). Here the high subsynchronous vibration showed up on both compressors during the full load, full pressure, full speed (FL/FP/FS) testing. The compressor train is rated at a maximum continuous speed (MCS) of 11,493rpm. The stability threshold speed was reached at about 7500 rpm on the LPC and at 10,600 rpm on the HPC. Both compressors in the train are of the back-to-back configuration with a relatively long center seal. The LPC has four impellers (two on each end) with spacing for two additional impellers. The HPC has two impellers (one on each end) with spacing for four more to be added at a later date when the process dictates the need for higher pressure ratio. The subsynchronous vibration is believed to be the result of high aerodynamic cross coupling introduced by the conventional grooved rotor and stationary labyrinth center seal. Furthermore, the location of the seal at an antinode for the first

forward mode increased the modal influence of the center seal on the stability of both compressors.

The second case involves a set of four compressors. These machines are six-stage, back-to-back machines that were originally installed on a platform in the North Sea. The original installed configuration was with only two impellers. As the process changed, resulting in lower suction pressure, additional impellers were added, two at a time until the full complement of six was in place. After each restaging, the machines exhibited high vibrations. Considerable effort was required to reduce the vibration to acceptable levels. In the mid-80s, one of these machines was converted to gas lubricated face seals. After the conversion, that machine was inoperable. Subsynchronous vibration levels of as high as 0.012 in, p-p were exhibited and, on at least one occasion, the center balance piston labyrinth was wiped open to a 0.065 in radial clearance.

Extensive rotordynamic analyses were conducted by both the manufacturer and the user. These analyses were done using a conventional rotor model that incorporated the shaft for stiffness and the sleeves and impellers as added masses and inertias. The modelling of forces on the rotor was limited at first to the bearing coefficients [5]. To calibrate the rotor model, the suspended rotating assembly was subjected to an experimental modal analysis. The results of this analysis were compared to the predicted free-free modes of the rotor model. Good agreement was found. However, the predicted eigenvalues on bearings did not agree well with the observed behavior of the machine. In search of better agreement, attempts were made to calculate the stiffness and damping coefficients of the labyrinths. The codes existing at that time provided wildly differing values for these coefficients. Reasonably good agreement was finally achieved with the inclusion of 50,000 lb/in cross coupled stiffness at the center balance piston location in the computer model.

In both cases, the subsynchronous vibration was eliminated through the use of the new pocket damper seal configuration described above. This new seal is unique and has been named the TAMSEAL™. In the second case, it was decided to install one constructed of a PAI (defined under Case 2) material at the center balance piston location. The PAI material is a high strength, high temperature engineering polymer. This modification, by itself, produced acceptable stability in the machine. The use of the PAI material in the manufacture of pocket damper seals, the robust design of these seals, and careful engineering of tolerances and thermal properties, enabled the design of a seal which runs at closer clearances than conventional labyrinth seals. This machine has had several full pressure surge events associated with emergency shutdowns since the installation of the pocket damper seal. There has been no observable degradation in the mechanical dynamic behavior of the machine due to those events.

### CASE 1—THREE IDENTICAL COMPRESSOR TRAINS

The machines in this case consisted of three identical compressor trains. Each train consisted of a gas turbine, a gear box, a low pressure compressor (LPC) and a high pressure compressor (HPC). Both compressors are of the back-to-back configuration. The operating speed was approximately 11,000 rpm. The LP compressor ran well in the high speed balancing bunker, but experienced severe subsynchronous vibration during the shop testing. The subsynchronous vibration was observed on the LPC as the running speed reached 7500 rpm. The vibrations increased above 150  $\mu$ m (5.9 mils) and the compressor was tripped, thus preventing it from reaching the operating speed. The subsynchronous vibration frequency was at 61.25 Hz, which corresponded to the first natural frequency of the rotor.

A similar shop test was performed on the HP compressor to establish the stability characteristics at full load and full pressure. The LPC was not used during this test. Subsynchronous vibration was observed on the HPC, but at a higher threshold speed than that observed on the LPC. The subsynchronous vibrations in this case appeared as the speed was increased from 11,000 rpm to MCS at a discharge pressure of 126 kg/cm<sup>2</sup> (1788 psi). The subsynchronous vibration frequency was at 87.5 Hz, which also corresponded to the first natural frequency of the rotor.

Based on these tests, it became necessary to reexamine the rotordynamic characteristics of both compressors in much greater detail. Special considerations were given to the seals and bearings, making use of the data obtained in the tests to help zero in on the source of the discrepancy between the earlier predictions and the shop test results. The LPC was examined first, since its threshold speed was much lower than the HPC compressor, thus making it the more difficult case to stabilize. A very thorough rotordynamic analysis was performed by the OEM, the bearings and seals supplier, and by the end user. The rotor model was verified by impact testing and measurement of the free-free modes. These measurements were used to bench mark the computer generated rotor model and, thus, account for the stiffening effects of the shrunk-on wheels and shaft sleeves. This process verified that the mass-elastic properties of the rotor were accurately accounted for. Next, the fluid film bearings were modelled. The existing spherical pivot tilt pad bearings were analyzed at the nominal, minimum, and maximum extremes of the manufacturing tolerances. FLEXUREPIVOT™ bearings (FPB) were also considered, due to their inherent performance characteristics and manufacturing technology which can limit the minimum and maximum tolerances to a very narrow range.

#### *Low Pressure Compressor (LPC)*

##### *Rotor Model Verification*

It was essential to scrutinize the complete analysis, and the rotor model was verified first to ensure that the mass elastic properties of the rotor were accurately modelled. This check was achieved by comparing the predicted free modes with those obtained through impact testing with the rotor suspended on flexible slings. The first two measured free-free modes agreed with the numerically predicted frequencies. This confirmed that the mass elastic properties of the rotor were adequately modelled. The computer generated rotor model is shown in Figure 7. The rotordynamic analysis program is based on the polynomial transfer matrix method developed by Murphy and Vance [7]. The bearings (shown as spring elements on the rotor model) are modelled as forces applied to the rotor. The labyrinth seals and the impellers are also modelled as forces applied to the rotor.

##### *Matching the Analysis to the Test Data*

The next step in the analysis was to simulate and benchmark the unstable operation observed during testing. The maximum continuous speed of the LPC is 11,493 rpm. During the full load, full pressure, full speed (FL/FP/FS) test, subsynchronous vibration was observed at an operating speed of 7500 rpm. The subsynchronous vibration frequency was about 3675 rpm (61.25 Hz). This corresponded to the first forward mode shown in Figure 8, which has an antinode at the center seal. This suggested that the cross coupling in the center seal has a significant modal influence in comparison to other elements in the dynamic system, and may be the major source of instability.

Speed dependent bearing coefficients were obtained for the existing spherical pivot, five pad tilt pad bearings at the minimum, maximum and nominal bearing clearances. These coefficients were obtained using a comprehensive tilt pad bearing

HIGH PRESSURE COMPRESSOR  
ROTOR MODEL  
Shaft Mass=587.057 kg Shaft Length=2365.480 mm C.G.=1174.800 mm

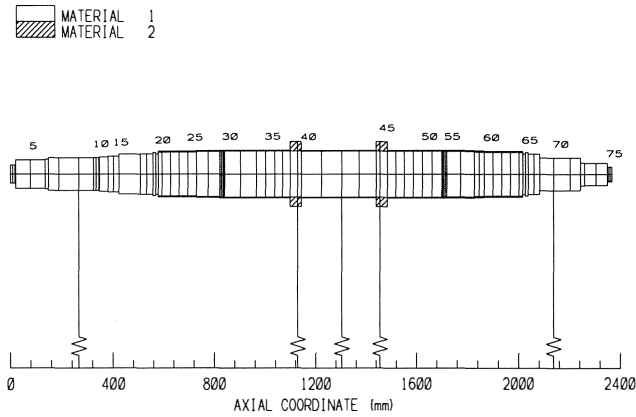

Figure 7. LPC Rotor Model.

ROTOR DYNAMIC MODE SHAPE PLOT  
LOW PRESSURE COMPRESSOR  
STABILITY ANALYSIS - LABYRINTH CENTER SEAL  
SHAFT SPEED = 7500.0 rpm  
NAT FREQUENCY = 3411.63 cpm, LOG DEC = -0.0211  
STATION 36 ORBIT FORWARD PRESSION

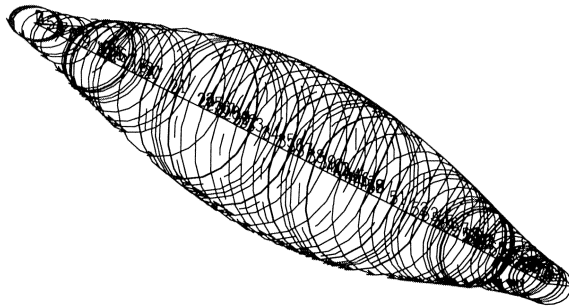

Figure 8. First Forward Mode of the LPC.

analysis program which includes thermal effects. The destabilizing effect of the impellers and seals was also considered. In general, the aerodynamic excitations present in impellers and seals are much more difficult to predict than the dynamic coefficients in fluid film bearings.

For the impellers, the aerodynamic cross coupling was estimated using Wachel's empirical formula:

$$K_{xy} = -K_{yx} = 6300 \text{ hp mol wt } \rho_o / (N D h \rho_s)$$

where:

- hp = stage horsepower
- mol wt = fluid molecular weight
- $\rho_o$  = discharge density
- $\rho_s$  = suction density
- N = speed, rpm
- D = impeller diameter
- h = restrictive dimension in flowpath

To allow calculation of the dynamic coefficients for the impellers, the compressor manufacturer provided the data in Table 1.

Table 1. Data for LPC.

	Test Condition	Design Condition
Sec-1 Horsepower (kW)	2524	5326
Sec-2 Horsepower (kW)	2395	5585
Sec-1 Suc. Density (kgf/m <sup>3</sup> )	39.4	26.1
Sec-1 Disch. Density (kgf/m <sup>3</sup> )	42.9	38.3
Sec-2 Suc. Density (kgf/m <sup>3</sup> )	42.8	38.1
Sec-2 Disch. Density (kgf/m <sup>3</sup> )	45.7	53.4
Molecular Weight	16.01	19.82
Speed (rpm)	7500	10946
Impeller Diameter (mm)	436.5	436.5
Restrictive Dimension (mm)		
Sec-1 1st Stage	20.60	20.60
Sec-1 2nd Stage	18.86	18.86
Sec-2 1st Stage	17.11	17.11
Sec-2 2nd Stage	15.63	15.63

Using the above data, the aerodynamic cross coupling was calculated for each impeller. The predicted values are shown in Table 2.

Table 2. Cross-Coupling at Impellers - LPC

Impeller Position	Cross-Coupling at 7500 rpm (lb/in)	Cross-Coupling at 10946 rpm (lb/in)
Sec-1 1st Stage	1704	3756
Sec-1 2nd Stage	1856	3790
Sec-2 1st Stage	1925	4423
Sec-2 2nd Stage	2107	4711

The cross coupling at the center labyrinth seal was estimated using a labyrinth seal analysis program. The center seal geometry is shown in Figure 9. This is an interlocking seal design with blades on the stator and a grooved rotor. The temperature and pressure of the gas at the center seal inlet and exit are shown in Table 3.

Table 3. Gas Temperature and Pressure - LPC

	7500 rpm	10946 rpm
Upstream Pressure (bar)	77.7	80.81
Downstream Pressure (bar)	58.4	50.69
Upstream Temperature (°C)	69.0	138.2

←  
*FLOW DIRECTION*



Figure 9. Center Seal Geometry for the LPC.

The gas composition is shown in Table 4.

Table 4. Gas Composition

Gas	Mol. Weight
CH4	0.85270
C2H6	0.05610
C3H8	0.02620
IBUT	0.00990
BUTA	0.00480
IPEN	0.00230
PENT	0.00130
HEXA	0.00190
C7H8	0.00150
OCTA	0.00110
IPRB	0.00040
DECA	0.00020
CO2	0.03450
WATR	0.00010
N2	0.00200
	19.8219

Using the labyrinth seal analysis program developed by Childs, et al. [8], the predicted cross coupling at stability threshold speed of 7500 rpm and at the MCOS of 10946 rpm was calculated and is shown in Table 5.

Table 5. Cross-Coupling at Center Labyrinth Seal - LPC

7500	10946 rpm
10525 lb/in	19272 lb/in

A stability analysis was performed using the calculated bearing coefficients along with the cross coupling at the center seal and the impellers. The analysis predicted stable operation when the theoretical values obtained from the seal programs were used. However, the shop testing indicated otherwise. This suggested, as other cases have in the past, the inability of existing seal programs to adequately model the cross coupled stiffness in labyrinth seals. In order to match the test results, the cross coupling at the center seal was increased to approximately five times the theoretically predicted value. This constitutes a very significant shortcoming with the present analysis tools. The predicted log dec for the first mode is shown in Figure 10.

Since the location of the center labyrinth seal would have the most influence on the stability of the machine (due to its size and location), it was thought that modifying this seal would constitute the most direct approach to solving the problem.

#### Solution to the Stability Problem

Back to back compressors with high differential pressure across the center seal have had a history of unstable operations. The most effective means of increasing the stability margin of these compressors is by eliminating (or substantially reducing) the destabilizing forces inherent in the labyrinth seals. Therefore, the investigation concentrated on replacing the existing labyrinth seal with an alternate more stable seal design. This suggested the use of the new damper seal, a pocketed labyrinth stator design with very high direct damping. The separation walls in this seal reduce the fluid circulation and the corresponding cross-coupled stiffness. The inlet tooth of each cavity has a tighter clearance compared to the exit tooth thus producing a diverging clearance in the direction of flow. The diverging

ROTORDYNAMIC MODE SHAPE PLOT  
LOW PRESSURE COMPRESSOR  
STABILITY ANALYSIS - LABYRINTH CENTER SEAL  
SHAFT SPEED = 10946.0 rpm  
NAT FREQUENCY = 3487.13 cpm, LOG DEC = -0.9638  
STATION 36 ORBIT FORWARD PRECESSION

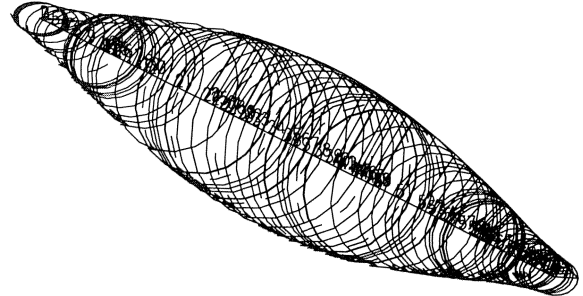

Figure 10. Predicted Logarithmic Decrement for the LPC.

clearance and pocketed design, along with optimization of the pocket volume, produce high direct damping while reducing the cross coupled stiffness. Although this seal design did not have significant field experience at the time, it was, nevertheless, a viable alternative based on the results that had been shown in laboratory tests. Its rugged design and its simplicity also made it the better choice in comparison to a honeycomb seal. The ease of manufacturing made it possible to machine in a very short time, which was a must in this case.

Honeycomb seals have been used to solve stability problems in many high pressure compressors [6]. Analysis with a honeycomb seal design showed that the compressor could be stabilized using this seal. The predicted log dec of the LP compressor increased to a positive (stable) value when the existing labyrinth center seal was replaced with a honeycomb seal. Ultimately, however, the honeycomb seal option was not viable for two reasons. First, the relatively long lead time required for the manufacture of a honeycomb seal would impact the delivery schedule for the compressor trains. Second, the optimum configuration for a honeycomb seal consists of a smooth rotor and a honeycomb stator. Zeidan, et al. [6], showed that in one application the predicted direct damping was 15 to 20 times lower for a honeycomb seal operating against a stepped rotor compared to a honeycomb seal operating against a smooth rotor.

However, changes to the stepped rotor configuration shown earlier in Figure 9 would necessitate machining the rotor and the high speed balancing would have to be repeated on all six rotors for the three compressor trains (one HPC and one LPC per train) and the two spare rotors for a total of eight rotors. These two factors weighed heavily against the honeycomb seal option that was eventually dropped from consideration. The investigation was therefore limited to alternate solutions that would not require modifications to the rotor and could be accomplished within a short time frame. This made the new pocket damper seal the prime candidate.

The optimum pocket damper seal configuration generally consists of a smooth rotor and a rough (toothed) stator. The smooth rotor (no steps or grooves) will minimize the surface area on the shaft that is responsible for dragging the fluid resulting in undesirable high swirl with its resultant cross coupling. However, due to the limitations imposed in this case that precluded any modifications to the rotating components, a less than optimum configuration was used. This configuration shown in Figure 11 consisted of a damper seal running against the

existing stepped (grooved) rotor. The pocket depths of the seal were optimized to maximize the direct damping at a frequency of 62.5 Hz under the constraint of a large number of blades to fit the grooved rotor. The dynamic force coefficients for this seal design are shown in Table 6. Using these coefficients in the rotordynamic model increased the predicted log. dec. from -0.96 with the conventional labyrinth to +0.48 with the pocket damper seal. The first forward mode is shown in Figure 12.

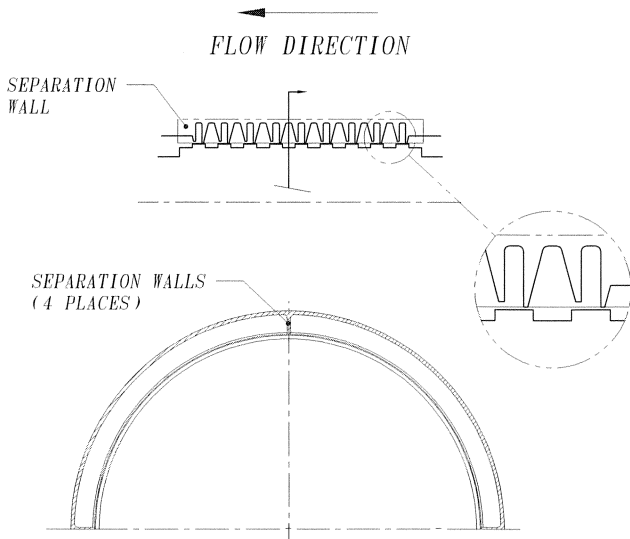

Figure 11. Pocket Damper Seal Configuration for the LPC.

ROTOR DYNAMIC MODE SHAPE PLOT  
 LOW PRESSURE COMPRESSOR  
 STABILITY ANALYSIS - TAMSEAL CENTER SEAL  
 SHAFT SPEED = 10946.0 rpm  
 NAT FREQUENCY = 3319.59 cpm, LOG DEC = 0.4810  
 STATION 36 ORBIT FORWARD PRECESSION

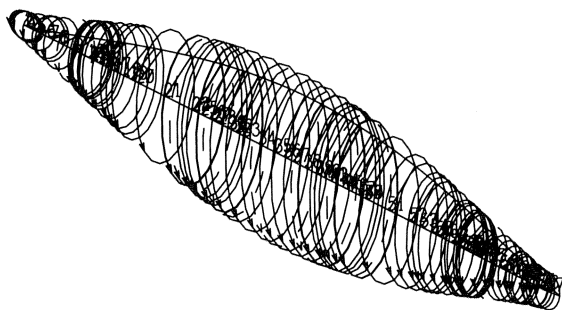

Figure 12. First Forward Mode with the Pocket Damper Seal.

The compressor was fitted with the damper center seal and tested with the existing spherical seated tilt pad bearings. At the same time the holes used for injecting gas (shunt holes) in a tangential direction against the shaft rotation at the center seal were reduced in number and size to increase the velocity. Shunt holes were also applied at the equalizing labyrinth seal on the thrust end of the rotor. The compressor was tested with this configuration and the subsynchronous vibration was eliminated. However, the synchronous vibration was unacceptable and the spherical pivot bearings were replaced with FPB bearings as described below. This final modification provided low synchronous vibrations and the compressors' rotordynamic performance satisfied all required limits on vibrations.

Table 6. Dynamic Coefficients for Pocketed Damper Seal - LPC

Kxx	Kxy	Kyx	Kyy
0.00 lb/in	0.00 lb/in	0.00 lb/in	0.00 lb/in
Cxx	Cyx	Cyx	Cyy
1.70 lb-s/in	0.00 lb-s/in	0.00 lb-s/in	1.70 lb-s/in

*Bearing Redesign*

The FPB bearing design has been shown to improve rotordynamic performance in many demanding turbomachinery applications (Chen, et al. [9]). Speed dependent bearing coefficients were obtained using a comprehensive bearing analysis program which includes thermal effects. The rotordynamic analysis was then performed with the pocket damper seal coefficients and the FPB bearing coefficients. The predicted log dec for the first mode was the same as the one shown in Figure 12.

The high speed balancing test data on the FPB bearings and the conventional spherical seated tilt pad bearings was not available for direct comparison. However, a more recent test with the same geometry and same size bearings was performed at a major compressor manufacturer in the Northeast. The results are shown in Figures 13 and 14 for an unbalance weight at the mid span and at the quarter spans respectively. There is a significant attenuation of the synchronous vibration amplitude based on these test measurements with the FPB bearings. The analysis, however, did not predict a difference between the two styles of bearings tested. This suggests that additional damping observed on the high speed balancing stand may be attributed to the squeeze film damping obtained from the fine wire EDM cuts on the under side of the pads. This damping effect is not modelled by the current bearing computer codes.

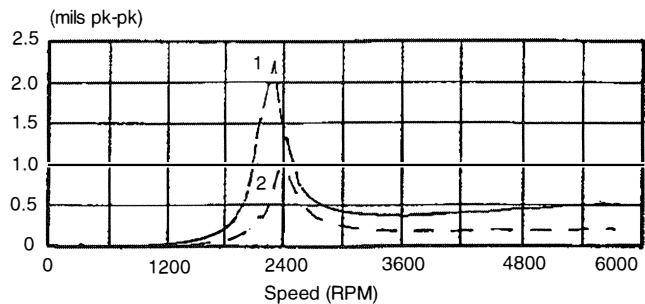

- 1 Spherical Pivot Tilt Pad Bearing
- 2 Flexure Pivot Tilt Pad Bearing

Figure 13. Unbalance Response with two Types of Bearings—Unbalance at Midspan.

**HIGH PRESSURE COMPRESSOR (HPC)**

The same analysis procedure presented above for the LPC was used for the HPC. The rotor model was verified by comparing the predicted free-free modes with those obtained through impact testing with the rotor suspended on flexible slings. The first two measured free-free modes agreed with the numerically predicted frequencies. This confirmed that the mass elastic properties of the rotor were adequately modelled. The computer generated model for the HP compressor rotor is shown in Figure 15.

The unstable operation observed during the shop test was simulated analytically. Speed dependent bearing coefficients were obtained for the existing spherical pivot, five pad tilt pad

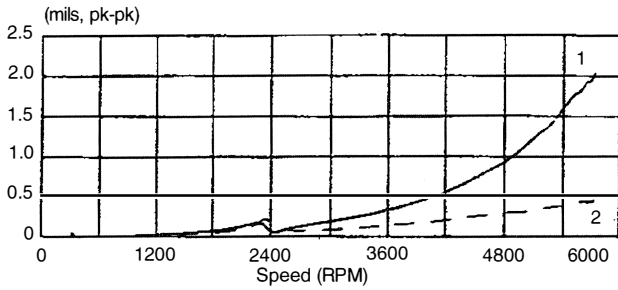

1 Spherical Pivot Tilt Pad Bearing  
2 Flexure Pivot Tilt Pad Bearing

Figure 14. Unbalance Response with two Types of Bearings—Unbalance at Quarter Span.

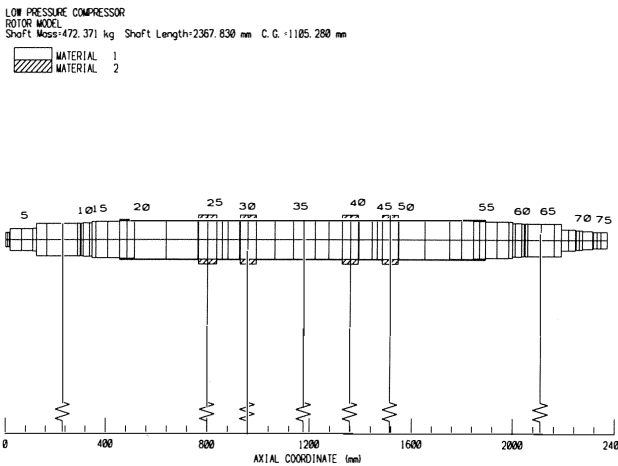

Figure 15. Rotor Model for the HPC.

bearings. Cross coupling at the impellers was estimated using Wachel’s empirical formula and the data in Table 7.

Table 7. Data for HPC

	Test Condition	Design Condition
Sec-1 Horsepower (kW)	2993	2612
Sec-2 Horsepower (kW)	3015	2673
Sec-1 Suc. Density (kgf/m <sup>3</sup> )	73.7	76.8
Sec-1 Disch. Density (kgf/m <sup>3</sup> )	83.7	91.0
Sec-2 Suc. Density (kgf/m <sup>3</sup> )	83.7	90.8
Sec-2 Disch. Density (kgf/m <sup>3</sup> )	93.0	105.3
Molecular Weight	21.3	19.82
Speed (rpm)	10692	10946
Impeller Diameter (mm)	436.5	436.5
Restrictive Dimension (mm)		
Sec-1 1st Stage	14.32	14.32
Sec-2 1st Stage	12.92	12.92

The predicted aerodynamic cross coupling at each impeller is shown in Table 8.

The cross coupling at the center labyrinth seal was estimated using a labyrinth seal analysis program. The temperature and

Table 8. Cross-Coupling at Impellers - HPC

Impeller Position	Cross-Coupling at 10692 rpm (lb/in)	Cross-Coupling at 10946 rpm (lb/in)
Sec-1 1st Stage	5895	4878
Sec-1 2nd Stage	6438	5414

pressure of the gas are shown in Table 9. (The gas composition was shown previously in Table 4).

The predicted cross coupling at 10,946 rpm was calculated and is shown in Table 10.

Table 9. Gas Temperature and Pressure - HPC

	10946 rpm
Upstream Pressure (bar)	131.5
Downstream Pressure (bar)	102.5
Upstream Temperature (°C)	92.7

Table 10. Cross-Coupling at Center Labyrinth Seal - HPC

10946 rpm
26638 lb/in

A stability analysis was performed using the calculated seal coefficient shown in the table above, but this also (as in the LPC case) did not result in a negative log dec. The cross coupling at the center seal was, therefore, increased until the log dec turned negative. The value required to reach a negative log dec and instability was 2.25 times the theoretically predicted value shown in Table 10.

A pocket damper seal was designed by the second author to operate against the existing grooved rotor. The damper seal force coefficients are shown in Table 11. FPB tilt pad bearings were also analyzed for the HPC. The rotordynamic analysis was conducted using the damper seal coefficients and the FPB bearing rotordynamic coefficients.

Shop Testing after Implementing the HPC Modifications

The first test used the pocket damper center seal and the existing spherical pivot tilt pad bearings. The shunt holes at the center seal location were reduced in number and size to increase the velocity of the gas. Shunt holes were also applied at the equalizing labyrinth seal on the thrust end of the rotor.

With this configuration, the subsynchronous vibration was eliminated. However, the synchronous vibration was unacceptable and did not satisfy the API specifications. The maximum peak-peak vibration levels were as follows:

- At MCS 42 μm (1.7 mil)
- At OVS 53 μm (2.1 mil)

Table 11. Dynamic Coefficients for Pocketed Damper Seal - HPC

K <sub>xx</sub>	K <sub>xy</sub>	K <sub>yx</sub>	K <sub>yy</sub>
0.00 lb/in	0.00 lb/in	0.00 lb/in	0.00 lb/in
C <sub>xx</sub>	C <sub>yx</sub>	C <sub>xy</sub>	C <sub>yy</sub>
1.69 lb-s/in	0.00 lb-s/in	0.00 lb-s/in	1.69 lb-s/in



Based on these results, it was decided to replace the existing spherical pivot tilt pad bearings with FPB tilt pad bearings while still retaining the pocket damper seal. The subsynchronous vibration was still eliminated as expected. In addition, with the FPB bearings, the synchronous vibration was substantially reduced and the HPC satisfied all required vibration limits.

At MCS 28  $\mu\text{m}$  (1.1 mil)  
 At OVS 32  $\mu\text{m}$  (1.3 mil)

A bar graph is shown in Figure 16 comparing the synchronous and overall vibrations between the spherical pivot tilt pad bearings and the FPB bearings.

**HIGH PRESSURE COMPRESSOR SYNCHRONOUS VIBRATION**

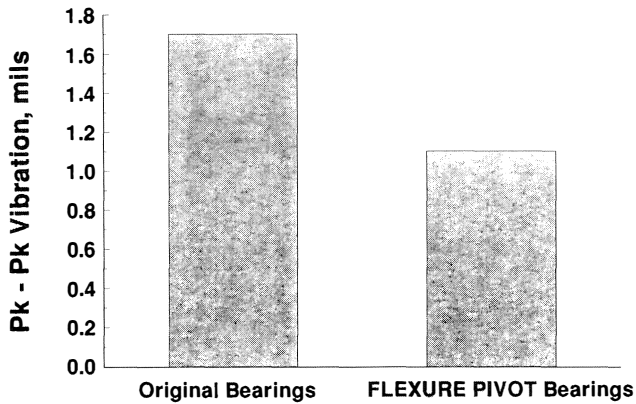

Figure 16. Synchronous Vibration Levels with Two Types of Bearings—HPC.

The synchronous and overall vibrations for the spherical pivot tilt pad bearings and the FPB bearings in both the LPC and HPC are summarized below.

At MCS 26  $\mu\text{m}$  (1.0 mils), 11  $\mu\text{m}$  (0.43 mils)  
 At OVS 31  $\mu\text{m}$  (1.2 mils), 12  $\mu\text{m}$  (0.47 mils)

The cascade plots in Figures 17 and 18 show the vibrations before and after the conversion to the pocket damper center seal and FPB bearings on the HP compressor. The results on the LP pressure compressor were very similar in eliminating the subsynchronous vibrations.

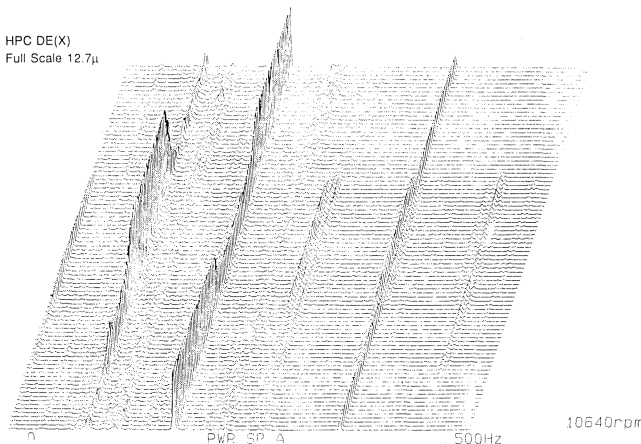

Figure 17. Cascade Plot of HPC Vibration before Modification.

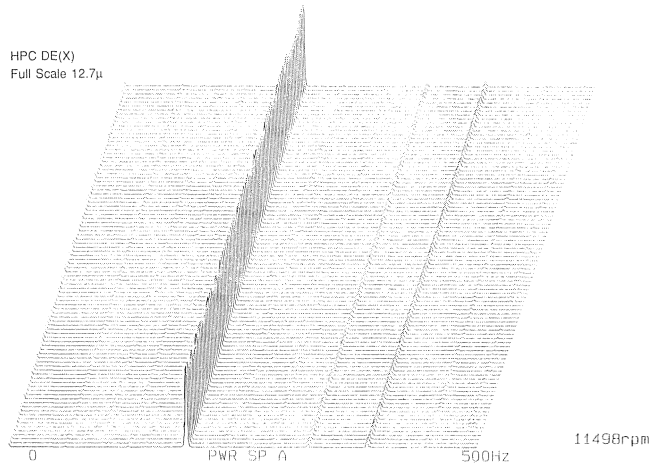

Figure 18. Cascade Plot of HPC Vibration after Modification.

**CASE 2-NATURAL GAS COMPRESSOR ON AN OFF-SHORE PLATFORM**

Case 2 involves the design and installation of a pocket damper center balance piston labyrinth seal manufactured from a high performance polyamide-imide copolymer (PAI). The material selection was based on the physical properties and chemical compatibility with the service conditions involved. The previous vibration history of this set of compressors involved severe labyrinth seal rubs during surge or operating upsets. The use of PAI for this seal prevents damage to the shaft/sleeve area during this type of excursion and permits tighter operating clearances. A subsequent emergency shutdown after the modified machine was put on line proved that the pocket damper design and PAI material choice were justified.

*Case 2 History*

The compressor involved is one of a set of four machines installed on a North Sea offshore platform. The machines are presently six stage, back-to-back impeller design with a center balance piston labyrinth seal as shown in Figure 19. The original installed configuration involved only two impellers. As the process changed, resulting in lower suction pressure, additional impellers were added, two at a time, until the full complement of six was in place. After each restaging, the machines exhibited high vibration. Considerable effort was required to reduce the vibration to acceptable levels. In the mid-1980s, one of these

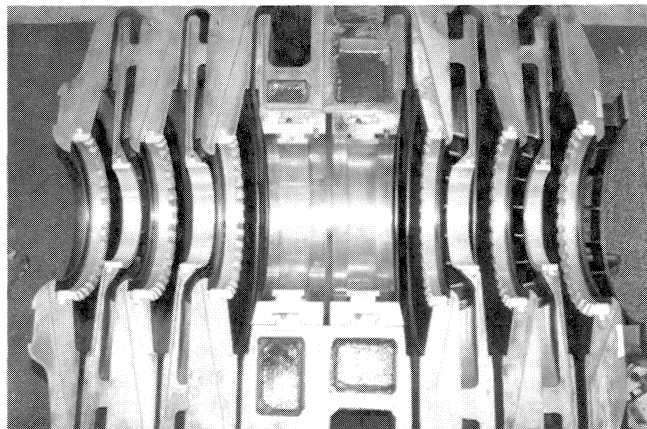

Figure 19. Center Labyrinth Seal Configuration in Split Case Compressor.

machines was converted to gas lubricated face seals. After the conversion, that machine was inoperable due to subsynchronous vibration levels of as high as 0.012 in, p-p. On at least one occasion, the center balance piston labyrinth seal was wiped open to a 0.065 in radial clearance.

Extensive rotordynamic analyses were conducted by both the original equipment manufacturer and the user. These analyses were done using a conventional rotor model that incorporated the shaft for stiffness and the sleeves and impellers as added masses and inertias. The support stiffness model was limited to the bearing coefficients [5]. The freely suspended rotating assembly was subjected to an experimental modal analysis. The results of these analyses were compared to the predicted free-free modes of the rotor model. Good agreement was found. However, the predicted eigenvalues on bearings did not agree with the observed behavior of the machine. In search of better agreement, attempts were made to calculate the stiffness and damping coefficients of the labyrinths. The codes existing at the time provided widely differing values for these coefficients. Reasonably good agreement was finally achieved with the inclusion of 50,000 lb/in cross coupled stiffness at the center balance piston labyrinth location.

Modifications attempted included several variations of a swirl brake at the center balance piston labyrinth location, antiwhirl devices at the impeller eyes, and optimized bearings with two degrees of freedom pads. The combination of all of these modifications rendered the machine operable as long as the labyrinth clearances were maintained at blueprint values. However, due to the installation and problems with the control system, these machines were subjected to occasional surge conditions. When this occurred, the labyrinth clearances would be increased and the machine then became unstable.

At this point, squeeze-film damper supported bearings were installed. This modification rendered the machines marginally operable. However, as the process continued to evolve the suction pressure continued to reduce, requiring the machines to operate at higher speeds to achieve the increasing differential pressure requirement. Eventually, the machines became unstable again. In 1991, a honeycomb seal was installed at the center balance piston. This modification completely stabilized the machines. The predicted logarithmic decrement increased from 0.2 to approximately 2.0 [6], and the machines became operable again.

Due to a decrease in gas volume available, one of these machines remained unmodified and was idled as an emergency spare. It was decided to install a pocket damper labyrinth seal manufactured from polyamide-imide (PAI) at the center balance piston location in this machine to improve its reliability. This modification, by itself, produced acceptable stability in the machine eliminating the need for bearing modifications.

Vibration spectra on the inboard bearing, vertical probe are shown in Figures 20 and 21 (note the change in the amplitude scale) before and after the seal modification. These data were taken with the machine clearances at blueprint values. The same relative change in probe vibration levels was evident on the inboard horizontal and outboard bearing vibration plots, but to a lesser magnitude. The vibration plot of the vertical probe on the inboard bearing shown in Figure 20 was taken when the compressor was equipped with the original standard labyrinths. The same vibration location data are shown in Figure 21 after the pocket damper labyrinth installation. The remaining probe location plots on the compressor show the same relative improvement.

Coast down data before and after the center pocket damper labyrinth installation are shown in Figures 22 and 23, respectively. These data were taken with the compressor internal clearances at blueprint values. The use of the unique pocket

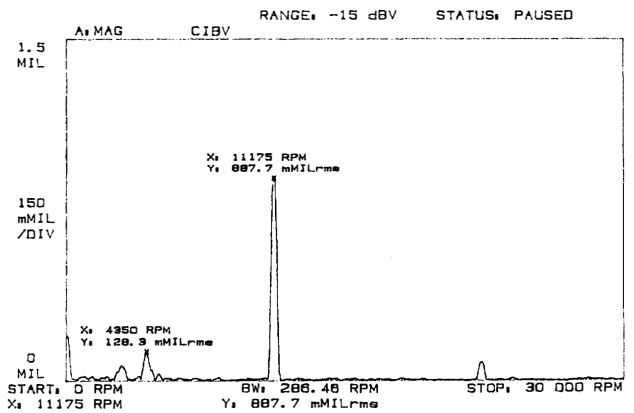

Figure 20. Vibration Spectrum with Standard Labyrinth Center Seals, Blueprint Clearances.

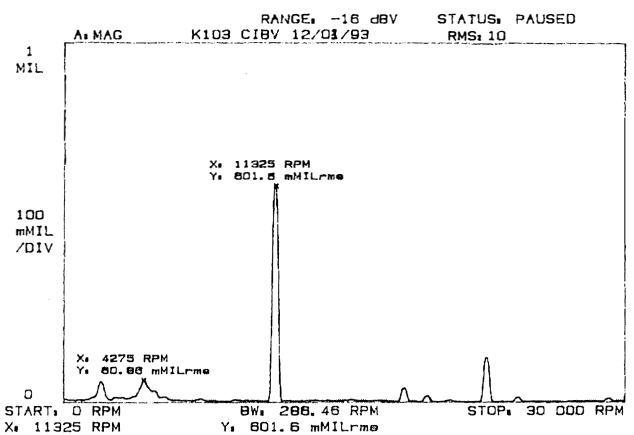

Figure 21. Vibration Spectrum with Pocket Damper Center Seal Labyrinths, Blueprint Clearances.

damper design coupled with the selection of a PAI seal material resulted in an economical and effective solution to the rotor instability problem. This machine has had several full pressure surge events associated with emergency shutdowns since the installation of the new seal. One of these very high vibration excursions resulted from a coupling lubrication failure. There has been no observable degradation in the mechanical dynamic behavior of the machine due to those events.

A severe vibration condition is shown in the plot at the inboard bearing, vertical probe on Figure 24. This ESD data was

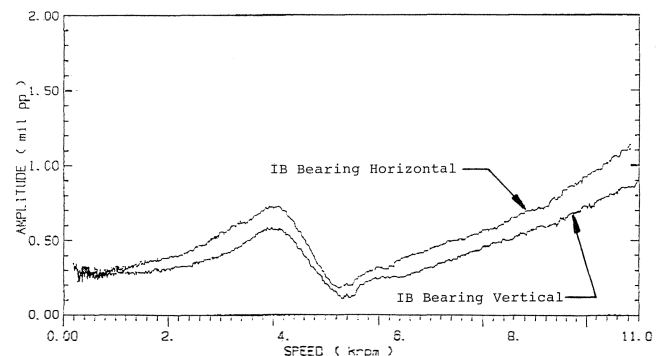

Figure 22. Coastdown Data with Standard Labyrinth Center Seal.

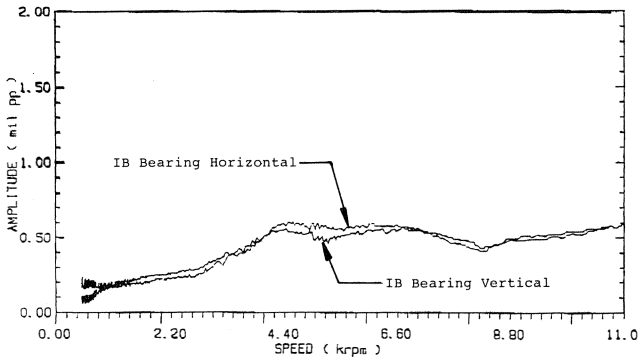

Figure 23. Coastdown Data with the Pocket Damper Center Seal.

taken on another compressor in the set; it is typical of the increased vibration experienced on these compressors after a severe vibration excursion caused by a surge or an ESD. The same data are shown in the plot on Figure 25 for the subject compressor, after installation of the pocket damper labyrinths, and after a severe ESD. Note that the pocket damper labyrinths have left the compressor operable and unaffected after the excursion. Other bearing probe data in the machine have been omitted for brevity, but they all show the same relative changes.

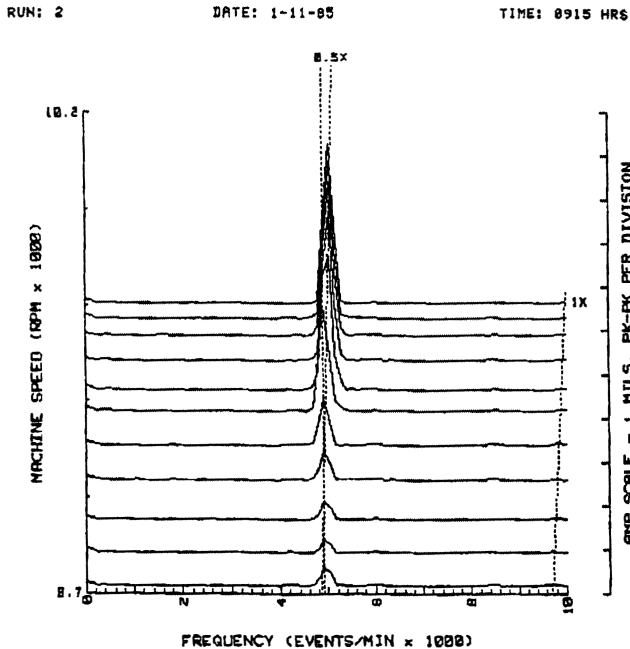

Figure 24. A Waterfall Plot at the Inboard Bearing, Vertical Probe Showing High. Vibration at Subynchronous Frequency after an ESD on another Compressor in the Set.

#### Compressor Operating Data—Case 2

The designed operating conditions of the compressor with the six stage impeller configuration are listed under “Pertinent compressor operating data.” Since the center balance piston labyrinth is actually a two-part (horizontally split) labyrinth, it is important to determine or estimate, fairly accurately, the temperatures of the various components at the center seal location. The sixth or final stage discharge temperature was used as the operating temperature for the high pressure seal. The low

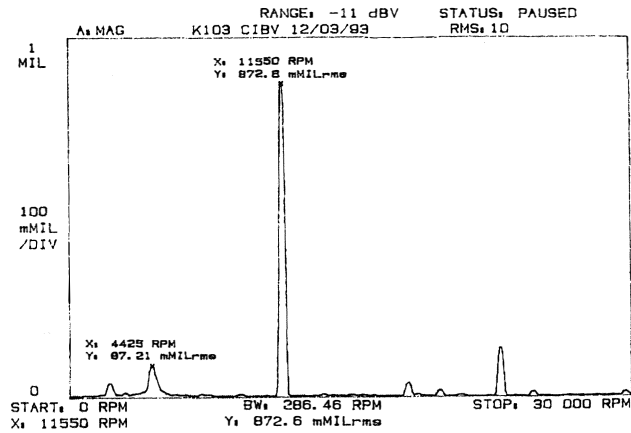

Figure 25. A Vibration Plot at the same Bearing Location on the Subject Compressor with the Pocket Damper Labyrinth Installed and after a Severe ESD Surge Excursion.

operating temperature was estimated to be equal to the third stage impeller discharge temperature. These temperature values assured a conservative design for the final operating clearances between the labyrinth inserts and the rotating element.

Pertinent compressor operating data:

- Suction pressure: 300 psig
- Suction temperature: 135°F
- Intermediate pressure: 600 psig
- Intermediate temperature: 170°F
- Discharge pressure: 1200 psig
- Discharge temperature: 205°F
- Shaft speed: 11,100 rpm
- Process fluid: natural gas

#### Copolymer Polyamide-Imide (PAI)

The selection of this amorphous copolymer as the material of choice for the labyrinth seal was based on the physical properties required for the compressor operating conditions. A bearing grade of this material was selected for its low coefficient of friction and excellent wear characteristics. High tensile strength and modulus at operating temperatures along with a high glass transition temperature were also of prime importance. Chemical compatibility of the seal material with the process had to be considered. Significant property data of the PAI selected for this seal are listed at the end of the next section.

#### Glass Transition Temperature (T<sub>g</sub>)

The glass transition temperature (T<sub>g</sub>) of a polymer is seldom listed in property data tables, yet is worthy of discussion at this point. T<sub>g</sub> roughly corresponds to the softening temperature of a polymer. The T<sub>g</sub> of a polymer can be determined by thermal analysis (Differential Scanning Calorimetry, ASTM test D-3418) or Dynamic Mechanical Analysis. Below its T<sub>g</sub>, a polymer is relatively rigid and glass-like. Above its T<sub>g</sub>, a polymer will be softer and more rubbery. On a molecular level, T<sub>g</sub> is the temperature at which the polymer chains are able to move freely past one another. This results in a dramatic change in properties. The strength and modulus will drop rapidly once a polymer reaches its T<sub>g</sub>. Creep and the coefficient of linear thermal expansion (CLTE) both increase rapidly above the T<sub>g</sub> [10]. It is important to select a material with a high enough T<sub>g</sub> to avoid failure due to operating temperature excursions. Polyamide-

imide has a Tg of 525°F, making it suitable for the compressor's operating conditions.

Significant physical properties of PAI (bearing grade) for this seal application are:

- Tensile strength (psi), 12,900 @ ambient (70°F), 6,400 @ 450°F
- Young's modulus (psi), 488,000 @ ambient (70°F), 250,000 @ 450°F
- Poisson's ratio, .42
- Coefficient of linear thermal expansion ( $10^{-6}$  in/in/°F), 19.3 @ 32°F to 100°F, 21.8 @ 170°F to 205°F
- Glass transition temperature, 525°F, Coefficient of Kinetic Friction, (@ 10,000 PV) 0.15, (@ 45,000 PV) 0.11
- Wear factor K, ( $10^{-1}$  in<sup>3</sup> - min/ft-lb-hr), 7.0 @ 10,000 PV, 52.0 @ 45,000 PV
- Compressive strength (psi) 18,300
- Chemical compatibility with natural gas, excellent

#### Sizing the Pocket Damper Seal Diameters

A proprietary computer program was used to correctly size the seal diameters [11]. Results from the program provide the free state machining dimensions for the seal inside and outside diameters. The program results also give the ambient and operating radial clearances, and the amount of compressive stress buildup in the PAI material at operating conditions. Required inputs for this program are listed for calculating the final seal dimensions and stresses below:

- Rotor outside diameter at ambient temperature (in)
- Effective rotor inside diameter at ambient temperature (normally 0.0)
- Effective rotor outside diameter at ambient temperature (in)
- Inside diameter of the housing at ambient temperature (in)
- Effective housing outside diameter (in)
- Ambient temperature (normally 70 F)
- Operating temperature of the rotor ( F)
- Operating temperature of the insert (PAI Seal, F)
- Operating temperature of the housing ( F)
- Operating rotor speed (rpm)
- Minimum desired radial operating clearance (in)
- Minimum desired od interference fit at operating conditions (in)
- Desired tolerance on the insert (labyrinth) outside diameter (in)
- Desired tolerance on the insert (labyrinth) inside diameter (in)
- Young's modulus for the rotor (psi)
- Young's modulus for the insert (psi)
- Young's modulus for the housing (psi)
- Thermal expansion coefficient for the rotor ( $10^{-6}$  in/in/ F)
- Thermal expansion coefficient for the insert ( $10^{-6}$  in/in/ F)
- Thermal expansion coefficient for the housing ( $10^{-6}$  in/in/ F)
- Yield stress for insert material (psi)
- Poisson's ratio for the rotor

- Poisson's ratio for the insert
- Poisson's ratio for the housing
- Density of the rotor (lb/in<sup>3</sup>)

#### Pocket Damper Seal Configuration and Fabrication

The pocket damper center balance piston seal consists of two separate labyrinths. The general seal configuration of the high pressure and low pressure labyrinths is illustrated in Figure 26. The high pressure labyrinth faces the sixth stage impeller discharge. The low pressure labyrinth faces the high pressure seal with the downstream side of this seal facing the third stage impeller discharge. Each seal contains four pressure dams producing four pockets located at 90 degree intervals, radially. The labyrinth seals were split at the compressor horizontal joint to facilitate installation. The horizontal joints were designed without expansion gaps. Rather, the outside diameters of the seals were sized to create sufficient compressive force at the split line at operating temperatures to provide a uniform seal at the split line. This was accomplished by using the difference in CLTE values between the PAI labyrinth material and cast steel housing.

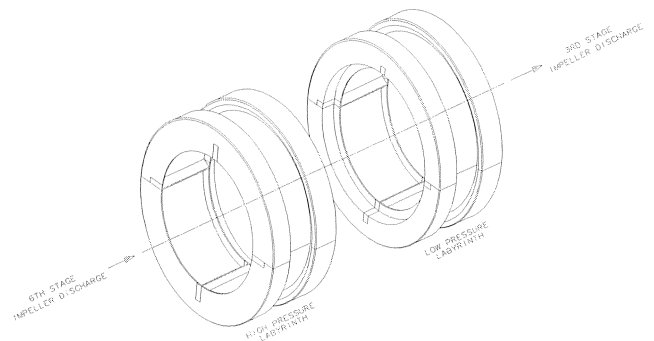

Figure 26. General Arrangement of the High and Low Pressure Balance Piston Pocket Damper Labyrinth Seals.

A robust design was used for the labyrinths and pressure dams. The labyrinth teeth had very small shaft contact areas to resist heat buildup due to possible heavy rubs. The new labyrinths were manufactured with rough inside diameter bore dimensions. Milled slots for the pressure dams had been machined to accept the dams. The dams were then pinned in place with PAI pins and bonded with PAI adhesive. The parts were then securely clamped (Figure 27) and placed in a programmable oven for a 30 hour cycle to 400°F to cure the adhesive. The high pressure side labyrinth and pressure dams were finish machined to the same inside diameter. The low pressure side labyrinth of each

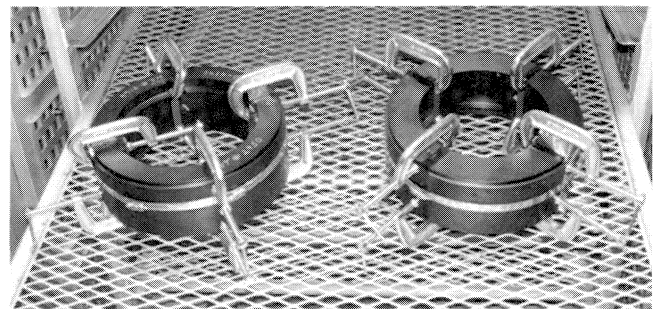

Figure 27. Labyrinth Seal Clamping Arrangement for Oven Cure Cycle.

seal had been finish machined to the correct, slightly larger inside diameter subsequent to the cure cycle. The same manufacturing process was used for both labyrinth seals.

The labyrinth seals installed in the case lower half are shown in Figure 28. Notice that the shaft contact areas of the labyrinths are less than 0.060 in wide while the body of the labyrinths and pressure dams are 0.375 in thick.

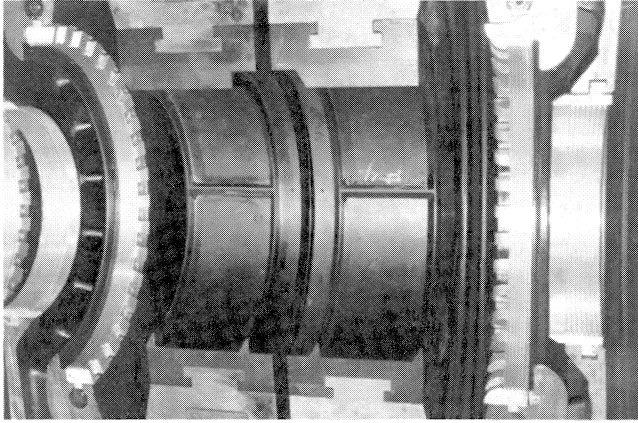

Figure 28. Pocket Damper Labyrinth Seals Installed in the Lower Case Half.

## CONCLUSIONS

In Case 1, the pocket damper seal proved to be a very rugged and reliable source of damping in the three compressors. Its ability to withstand high pressures and to fit as a drop-in replacement for conventional labyrinth seals made it especially advantageous in comparison to honeycomb seals. Another advantage this seal has over honeycomb seals is the high damping it can provide in relatively short axial length seals. This makes it very suitable for fitting at impeller eye seals and shaft interstage seals.

The reduction in synchronous vibration levels with the FPB bearings suggests that these bearings provide more direct damping than the existing spherical pivot tilt pad bearings. Independent testing on a high speed balance stand by another compressor manufacturer has shown similar results. This suggests that either the spherical pivot bearings provide less damping than predicted by the analysis programs or that FPB bearings provide more damping than predicted. The bearing manufacturer is currently testing the effect of the narrow wire EDM passages on the underside of the pads. This investigation and testing will verify if the squeeze film damping mechanism inherent with this style of bearing is the source for the additional damping.

In Case 2, the installation of a pocket damper labyrinth seal, made of PAI material, at the center seal location of the compressor was an economical solution to eliminate the rotor whirl instability. Considering the prior effort and expense of modifications to the other three identical machines to achieve rotor stability, this design change was relatively simple and straightforward. Careful engineering of tolerances and making the best use of the thermal properties and strength of the PAI material enabled the design of a damper seal that will run with closer clearances than conventional seal materials while providing

improved rotor stability. The emergency shutdowns and surge excursions that have occurred with this compressor since the modification, with no measurable degradation, prove the concept of PAI pocket damper labyrinth seals.

## ACKNOWLEDGMENTS

The authors would like to thank John Platt, Amoco Engineering and Construction and Lester Palliser, Amoco Polymers for suggesting the Case 2 modification and for taking the time to assist in verifying the accuracy of Case 2 in this study. Terry Ashmore, Amoco Production, coordinated the actual installation on the North Sea platform and assisted in obtaining startup and operating historical data. The third and fourth authors would like to acknowledge the help and support provide by the technical staff of the user and the OEM for Case 1.

## REFERENCES

1. Alford, J. S., "Protecting Turbomachinery from Self-Excited Whirl," *Journal of Engineering for Power*, 87, pp. 333-344 (1965).
2. Murphy, B. T., and Vance, J. M., "Labyrinth Seal Effects on Whirl Stability," #C306/80, I.Mech.E. Proceedings, pp. 369-373 (1980).
3. Vance, J. M., Zierer, J. J., Jr., and Conway, E. M., "Effect of Straight Through Labyrinth Seals on Rotordynamics," *Vibration of Rotating Systems, DE-Vol. 60, ASME Vibrations Conference*, pp. 159-171 (1993).
4. Vance, J. M., and Shultz, R. R., "A New Damper Seal for Turbomachinery," *Vibration of Rotating Systems, DE-Vol. 60, ASME Vibrations Conference*, pp. 139-148 (1993).
5. Kocur, J., Platt, J. P., and Shabi, L., "Retrofit of Gas Lubricated Face Seals in a Centrifugal Compressor," *Proceedings of the Sixteenth Turbomachinery Symposium*, Turbomachinery Laboratory, Texas A&M University, College Station, Texas (1987).
6. Zeidan, F., Perez, R., and Stephenson, E. M., "The Use of Honeycomb Seals in Stabilizing Two Centrifugal Compressors," *Proceedings of the Twenty Second Turbomachinery Symposium*, Turbomachinery Laboratory, Texas A&M University, College Station, Texas (1993).
7. Vance, J. M., *Rotordynamics of Turbomachinery*, New York, New York: John Wiley & Sons (1988).
8. Childs, D. and Scharrer, J., "An Iwatsubo Based Solution for Labyrinth Seals: Comparison to Experimental Results," *Journal of Engineering for Gas Turbines and Power*, 108, pp. 325-331 (1986).
9. Chen, W. J., Zeidan, F. Y., and Jain, D., "Design, Analysis, and Testing of High Performance Bearings in a High Speed Integrally Geared Compressor," *Proceedings of the Twenty-Third Turbomachinery Symposium*, Turbomachinery Laboratory, Texas A&M University, College Station, Texas (1994).
10. Rodriguez, F., "Principles of Polymer Systems," Third Edition, New York, New York: Hemisphere (1989).
11. Sizer 1.2, Rotordynamics-Seal Research, North Highlands, California (1993).

