

**GUIDELINES FOR REDUCING THE NOISE LEVEL OF A CENTRIFUGAL AIR COMPRESSOR INSTALLATION****John Badini**

Senior Product Engineer, PE  
FS-Elliott Co., LLC  
Export, PA USA

**Paul A. Brown**

Product Engineer, PE  
FS-Elliott Co., LLC  
Export, PA USA



*John R. Badini is Senior Product Engineer at FS-Elliott Company and just received his 25- year service award. He is a registered Professional Engineer with the Commonwealth of Pennsylvania. His areas of expertise include rotor dynamics, acoustics, vibration analysis, modal analysis, structural analysis and lubrication systems. He has worked on numerous prototype development projects during his career, which involved agricultural, mining, and turbomachinery. Mr. Badini holds a U.S. Patent on a vibration isolation device developed for agricultural equipment. Mr. Badini obtained his B.S. Degree (Mechanical Engineering, 1972) from West Virginia University.*



*Paul A. Brown is a Product Engineer with 14 years of service at FS-Elliott Company. His expertise includes acoustics, vibrations, rotor dynamics, heat exchangers, pressure vessels, and test systems. He has worked on a number of design and development projects involving compressors, blowers, power boilers, heat exchangers, and test facilities. Mr. Brown is a registered Professional Engineer in the Commonwealth of Pennsylvania. He obtained his B.S. degree (Mechanical Engineering, 1993) from Pennsylvania State University and his M.S. degree (Mechanical Engineering, 2000) from Carnegie Mellon University.*

**ABSTRACT**

This paper will review the best practices for installation of a centrifugal air compressor without a sound enclosure to obtain the best acoustic environment for reduced operating noise levels. An overview of the noise sources associated with a centrifugal air compressor will be discussed along with the noise attenuation techniques. Moreover, proper selection and installation of accessory hardware associated with the compressor installation will be addressed, since the accessory hardware can often generate higher noise levels than the compressor if not selected and installed correctly. Guidelines

for valve sizing, proper lagging of piping and valves for noise reduction, drain line noise attenuation, inlet silencer selection, discharge silencer selection and silencer installation will also be explored.

The refining, petrochemical, oil and gas, automotive, steel, electronic and industrial applications utilize centrifugal air compressors to provide utility air to support manufacturing their processes. They are often purchased to meet a specified noise level based on customer site requirements. Compressors that meet the noise requirement without using a complete sound enclosure are preferred. This is due to both the high cost associated with sound enclosures and because sound enclosures make access to the compressor difficult for maintenance. Figure 1 shows a typical centrifugal air compressor package for a refinery application.



*Figure 1. Centrifugal Air Compressor*

Proper site development is important for reduced noise levels while the equipment is in operation. Outdoor installations do not exactly replicate a Free Field noise environment; indoor installations are often reverberant in nature because of building construction. In any case, when the compressor is in operation, the noise level measured with a sound level meter is often higher than the actual compressor generated noise. This paper will provide guidelines on how to achieve compressor installation noise objectives.

## INTRODUCTION

Sound levels should be considered in regard to air compressor installations. The noise comes from the compressors, the compressor accessories and extraneous equipment. It is amplified by the reflective surfaces in the facility. Unfortunately, sound levels are often neglected during the procurement process. Once the plant is operating, neighbors or personnel may raise complaints about the noise level. Although post-construction sound treatment is possible, it is also expensive.

This paper aims to present good practice in the compressor facility design so that noise problems can be prevented. The first look is at the nature of the installed noise. This is followed by a detailed description of common noise sources. Good installation design will be given under the topic of Best Practices. Finally, Appendix A presents a short discussion on the use of acoustic intensity equipment to measure sound emission levels within an *in situ* environment.

### FREE FIELD

Compressor sound ratings are always given as sound emission levels in Free Field conditions. A Free Field is an acoustic environment which is free from bounding surfaces and undisturbed by other sources of sound. (Reference Figure 2) The Free Field sound emission rating is a benchmark. It stays constant regardless of the installation.

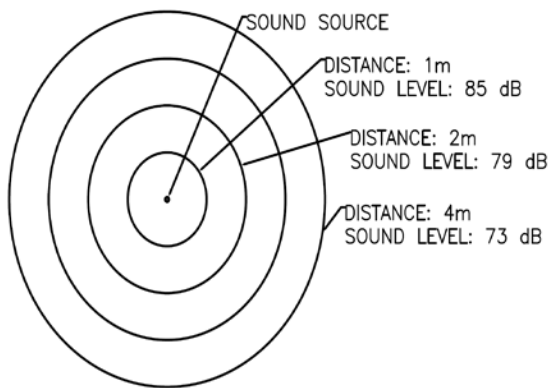

Figure 2. Free Field.

In a Free Field, the sound pressure level decreases by 6 dB for each doubling of distance to the source; provided the measurements begin at a distance from the source that is several times the largest dimensions of the major source. One way to verify the Free Field characteristics of an installation is to take sound readings at several points. Measure the sound level at 1 m, 2 m, 4 m, 8 m, and 16 m. In a Free Field, each measurement will be 6 dB less than the previous one.

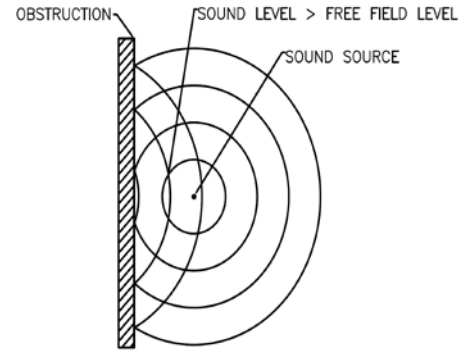

Figure 3. Reflective Plane.

With air compressors, a Free Field environment seldom occurs because the installation site includes many reflective surfaces and extraneous noise sources. The installed sound level is called the *in situ* sound level. As shown in Figure 3, when an observer takes a measurement between the sound source and the reflective surface, the level will be higher than the emission sound level from the source. Additional sound sources and reflective surfaces will serve to further amplify the *in situ* sound level.

### CENTRIFUGAL COMPRESSOR NOISE SOURCES

Like any sizeable machine with moving parts and flowing fluid, centrifugal compressors generate some level of noise. Some small fraction of the compressor input power is converted to noise and vibration. In general, the larger and more powerful the machine, the greater the noise emissions will be.

Compressors are typically driven by motors or steam turbines. Motors have three primary sources of sound: mechanical shaft vibration, cooling fans, and magnetostriction. Shaft vibrations at one or more times shaft revolution excite the air directly or indirectly by exciting the natural frequencies in the motor's structure. Cooling fans produce a sound pressure pulse each time a blade passes. The individual pulsations combine to form a tone with a frequency equal to the product of the number of blades and the speed of rotation. As the cooling air passes through the motor, turbulence and eddies form noise. Another possible source of noise is the magnetostriction of the motor laminations. Time varying electromagnetic forces cause the magnetic parts of the motor to expand and contract at the utility power line frequency and its harmonics. This is a source of line frequency hum.

Steam turbines are dominated by the high velocity steam flow along with the blade passing phenomena. High velocity, even choked, flow through the governor valve, nozzles, and blades can generate a great deal of noise emission. As usual with turbomachinery, the blade passing frequency will appear in the sound signature.

Like steam turbines, centrifugal compressors have moving blades. The blades produce sounds at their passing frequencies.

Gearing noise comes from the gear-to-gear meshing and vibration. Harmonics of the various shaft speeds appear from shaft vibration as well as manufacturing variations like pitch-line runout. Usually the dominant frequency is the gear tooth mesh frequency. Each time two teeth mesh, a small sound is

generated. This will have a frequency equal to the product of the rotating speed and the number of teeth on the gear.

Noise appears any time turbulence is induced in the flow of the working fluid. Obstructions like thermowells create turbulence. Changes of direction caused by pipe fittings such as tees and elbows also disturb the flow resulting in noise emission. Valves are one of the dominant flow noise sources in a compressor installation. Partially open inlet or unloading valves can create turbulent flow fields and commensurate noise emissions.

Poorly designed piping can also suffer from standing wave resonance and sonic shock. The gas in a pipe has a natural resonance frequency. Sound levels are amplified when the excitation frequency matches the natural frequency. Many musical instruments such as organs or flutes operate on this principle. In industrial compressors, the large pipe sizes resonate at lower frequencies than the compressor's blade passing excitation frequency. Occasionally, valves or flow obstructions can excite low frequency standing waves in compressor piping. Sonic shock occurs when pipe flow velocities reach the speed of sound. A shock wave produces a great deal of noise and piping vibration over a broad frequency band.

For control purposes, centrifugal air compressors are usually equipped with unloading valves. Excess air passes through the valve and in some control modes, exits to the atmosphere. The high flows and pressure drops require the installation of vent silencers.

Blade passing noise from the compressor travels opposite the air flow to exit through the inlet air filter. Even basic filters can provide attenuation, particularly for the high frequency components. Care must be taken to match the compressor to a suitable air filter.

Off-design operation of the compressor can be an unexpected source of noise. Compressor surge contributes a fluctuating broadband excitation. When the compressor is operating at or near choke (stonewall), the higher velocities are a source of high frequency and whistling noises. Care must be taken in control system design and operation to avoid both surge and choke.

## BEST PRACTICES

This section will summarize the best practices for obtaining reduced noise levels for both indoor and outdoor compressor installations. Specific information related to the accessories and noise treatments referenced in this section are described in the Accessory and Hardware Treatment section. Figure 4 shows the general arrangement for the accessories and hardware for a centrifugal air compressor installation.

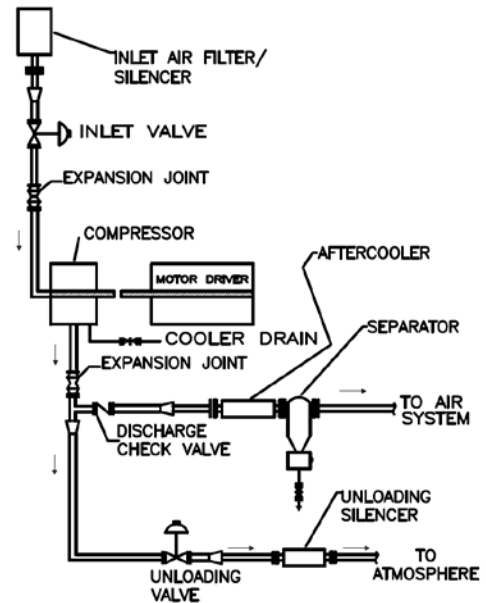

Figure 4. General Arrangement of Accessories and Hardware.

The local sound level is increased when multiple units are placed together. For lowest sound levels, compressors should be located well away from other compressors and other sound emitting equipment. The illustration below shows that two compressors rated for 85 dBA installed within close proximity of each other will have a combined level of approximately 88 dBA when measured between the compressors

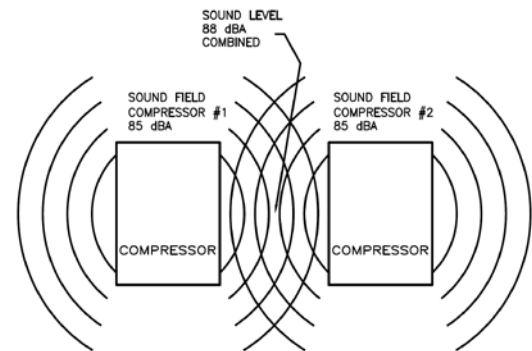

Figure 5. Combined Noise Effect of Two Compressors Operating.

All piping connected to the inlet and discharge of the compressor should be sized to minimize the air velocity. A good rule of thumb is to keep the inlet piping diameter the same as the compressor inlet pipe size and discharge piping line size the same size or larger than the compressor discharge connection. Another rule of thumb for keeping the noise generated from air flow to a reasonable level is to keep the air velocity below 150 ft/second. This is accomplished by sizing the piping accordingly.

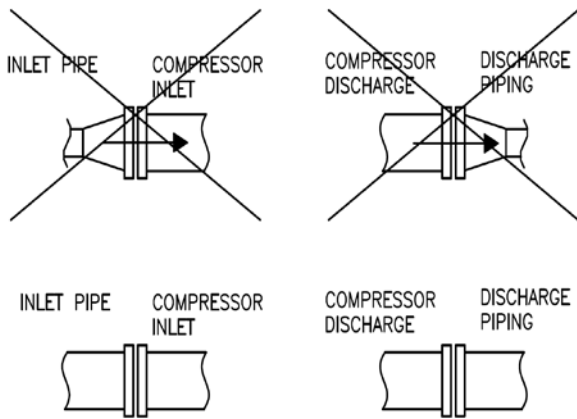

Figure 6. Inlet and Discharge Piping Size.

Piping size is particularly important between the unloading valve and the unloading silencer. Immediately after the unloading valve, the pipe diameter should be increased to that of the discharge silencer inlet flange size which is typically larger than the compressor discharge pipe size and unloading valve discharge line size.

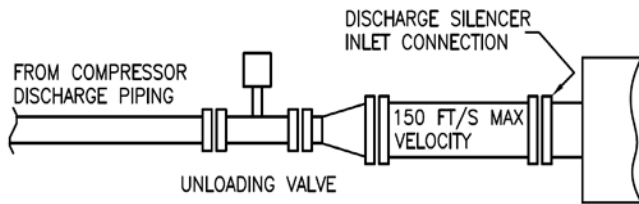

Figure 7. Unloading Valve Discharge Silencer Piping Arrangement.

All inlet, discharge, and unloading piping, expansion joints, and valves should be treated with acoustic insulation and metallic lagging. The insulation selection and installation should follow the guidelines of ISO 15665 or an equivalent national standard.

Condensate drain lines should be piped to an enclosed or otherwise silenced sump. Both condensate drain traps and notched valves should be equipped with drain mufflers. All piping associated with the drain lines should be treated with acoustic insulation and metal lagging.

For best acoustic performance, the inlet filter silencer and unloading silencer should be installed outdoors. The inlet filter silencer and discharge silencer exhaust should be mounted at an elevation such that they are well away from the compressor and normal personnel access areas. They should be mounted above adjacent buildings, walls, or other equipment to prevent reflection of the sound.

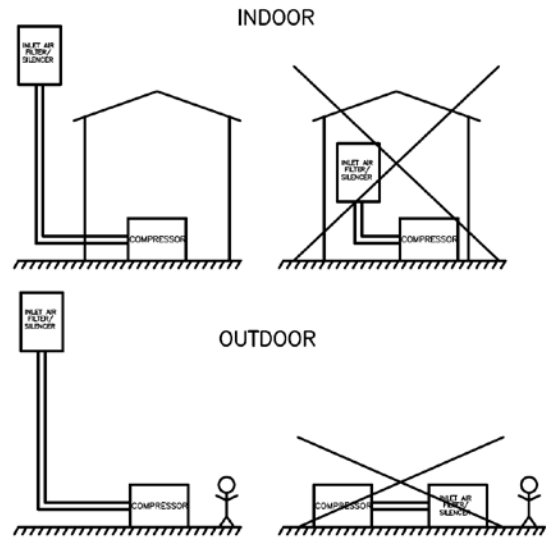

Figure 8. Inlet Filter/Silencer Installation.

The exhaust end of the discharge silencer should be oriented in a direction that is free from any reflective surfaces. Keep the discharge 3 – 5 meters above personnel areas. The silencer should never be installed with the silencer discharge pointed vertically downward. Figure 9 shows installation arrangements for the discharge silencer.

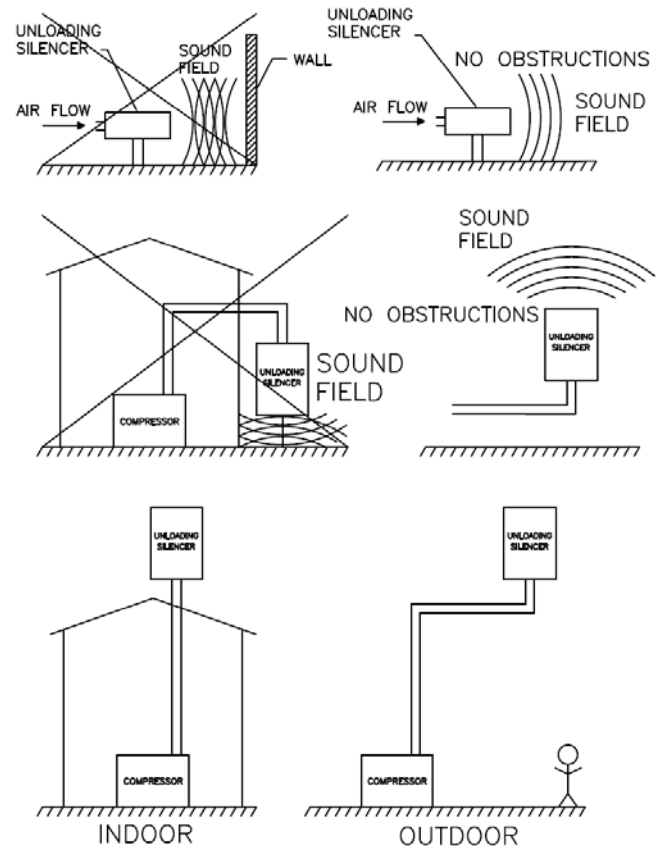

Figure 9. Discharge Silencer Installation.

In lieu of bolting the compressor base to the floor, vibration isolation mounts can be used. See Figure 10 for an example of a typical isolation mount. These mounts need to be selected such that they isolate the driver running speed frequency from being transmitted into the floor, which could excite structural resonances.

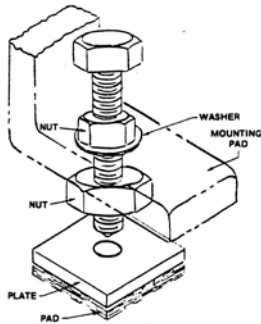

Figure 10. Compressor Isolation Pad.

Special attention should be given to the compressor foundation. The compressor foundation should be designed to avoid resonant running speed frequencies of the driver. (50 or 60 Hz). The foundation resonant frequency should be designed for a minimum separation margin of 20 % above or below the primary driver running speed frequency. There should be similar separation margins with up to the fourth harmonic of the driver primary running speed frequency. A foundation resonant frequency above the fundamental driver speed of the compressor is preferred. The foundation should rest entirely on natural rock or entirely on solid earth and arranged so that outside vibration are not transmitted to it. Where foundations must be supported by floor beams, a vibration dampening material should be installed between the beams and foundation.

Precautions must be taken with regard to outdoor installations that incorporate a sun/weather roof installed over the compressor. Normal building roof height is recommended to allow for maintenance of the compressor. Metal roof support columns should incorporate vibration isolation pads for the prevention of structural resonance induced by equipment operation. The roof interior will require acoustic treatment. Acoustic materials rated for outdoor environment should be used and selected for the best noise absorption for the frequencies generated by the high speed running components of the compressor.

Compressor indoor installations require the building to be constructed such that sound reverberation is limited. All of the aforementioned best practices are still applicable for an indoor installation.

## ACCESSORY AND HARDWARE APPLICATIONS

The previous section provided a general overview of best practices for reducing noise. This section will address specific accessories and components along with their proper selection and application.

## Compressor Driver Noise

The driver of the centrifugal compressor is an integral part of the compressor package. Electric motor drives and steam turbine drives are typically used. The noise levels provided by driver suppliers are unloaded noise levels. A typical noise increase of 3 dBA can be expected when going from no load to the rated load of the driver. This increase may be greater depending on the manufacturer and driver construction. Typically, steam turbine drives can be purchased with sound treatment (Acoustic Wraps) for reduced noise levels and motor drives can be purchased that are designed for reduced noise levels.

In order to meet a specified noise emission level for the compressor package including the driver, the loaded noise level of the driver must usually be less than that of the complete package. If the requirement is to meet 85 dBA for the package, the driver will usually need to have a sound emission level less than 85 dBA. The compressor supplier typically purchases the driver from a third party. The purchaser should pay particular attention to the driver data sheets provided by the supplier. In particular the driver data sheet should have the motor unloaded noise specified as a maximum of 82 dBA unloaded. Drivers with unloaded noise level of 80 dBA are preferred since most driver suppliers qualify their measurements by a +/- 2 dBA tolerance.

## Inlet Filter Silencer

An inlet air filter is required as part of the centrifugal air compressor installation. These filters can be purchased such that they provide noise silencing in addition to filtering. Figure 11 shows a typical inlet filter silencer.

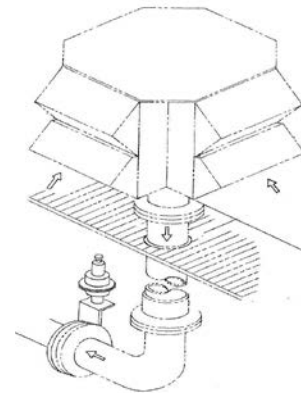

Figure 11. Inlet Filter Silencer.

Depending on the noise level generated by the compressor, an inlet silencer downstream of the filter may also be required. In addition to meeting the required noise level, the hardware selected must also meet flow requirements, filtration requirements and pressure drop limitations for compressor aero performance. The following discussion gives guidelines for selecting an inlet filter silencer to meet 85 dBA measured at 1 meter from the intake weather hood opening.

Inlet filter silencer suppliers typically provide noise attenuation characteristics for the inlet filter silencer as dB insertion loss (IL). The noise data is particular to a

filter/silencer with rated capacity and filtration to handle the compressor nominal inlet flow rate and maximum allowable pressure drop specified by the compressor supplier. Table 1 shows the insertion loss values for a typical silencer.

The human ear is not responsive to very low or very high frequencies. It is more sensitive to the range of frequencies that are typical of speech. "A" weighting takes into account the human ear's perception at different octave band frequencies. Table 1 shows the dB values for "A" weighting that are applied to each octave band. Subtract the "A" weighting value from each linear octave band level to obtain "A" weighted octave band level.

The published insertion loss values are for octave bands and have linear weighting applied as opposed to "A" weighting.

In order to calculate the estimated silencer noise at 1 meter from the intake weather hood opening, noise level data must be provided by the compressor supplier in octave bands measured at the compressor inlet without a filter silencer installed. Table 1 shows un-attenuated octave band noise data provided by a centrifugal compressor supplier.

The overall dB level is the logarithmic sum of each octave band level as defined by Equation 1 where x1 through x8 are the octave band levels in dB.

$$\text{Overall dB} = 10 \text{ Log} (10^{x1/10} + 10^{x2/10} + 10^{x3/10} + 10^{x4/10} + 10^{x5/10} + 10^{x6/10} + 10^{x7/10} + 10^{x8/10})$$

*Equation 1.*

The overall "A" weighted (dBA) level is also calculated using Equation 1. In this case, x1 to x8 are the "A" weighted octave band levels in dBA.

Table 1 illustrates the technique for using octave band insertion loss data. It also provides an example for the calculation of overall sound level from the octave bands.

Center Freq. Hz	Compressor Linear Un-Attenuated. dB	Inlet Filter Silencer Insertion loss dB	Calculated Linear Level Attenuated dB	"A" Weighting per Octave Band dB	Calculated Attenuated Level dBA
63	87.7	12.75	75	-26.2	48.8
125	90.2	13.75	76.5	-16.1	60.4
250	93.0	14.75	78.3	-8.6	69.7
500	96.2	15.8	80.4	-3.2	77.2
1000	96.6	17.1	79.5	0	79.5
2000	95.0	18.5	76.5	1.2	77.7
4000	92.5	23	69.5	1	70.5
8000	103.6	23.5	80.1	-1.1	79.0
Overall	106.0 dB		87 dB		84.8 dBA

*Table 1. Inlet Filter/Silencer Noise Level Example.*

Using the inlet filter/silencer insertion loss values shown and the measured octave band linear noise levels for the

compressor, the overall dBA level is 84.8 dBA at 1 meter from the intake weather hood opening.

Although the filter silencer meets 85 dBA, it will also add to the compressor overall noise level if not installed without some forethought. For best acoustic performance in indoor compressor installations, the filter silencer should be installed outside of the building. For outdoor compressor installations, the filter silencer should be at least 10 meters away from the compressor inlet. It should be mounted at an elevation above adjacent buildings, walls, or other equipment. For either outdoor or indoor installation, the piping from the filter outlet to the compressor inlet should also be lagged. The use of proper lagging materials will be described in the piping noise reduction section.

*Unloading Valve and Silencer*

The unloading valve and silencer need to be sized together. The unloading valve reduces unwanted compressed air from line pressure to atmospheric pressure. The amount of flow depends upon the compressor mode of operation. During startup, after a surge, and prior to shutdown, the unloading valve can be passing the entire output flow of the compressor. The exact details will vary depending upon the compressor control system logic.

While the unloading valve is in operation, all of the energy stored in the pressurized flow is converted to heat, noise, and vibration. When the flow energy is being released at a rate of thousands of kilowatts, the results can be deafening. A good silencer will reduce this to modest levels.

Many compressor manufacturers use butterfly valves for unloading the compressor. Butterfly valves are inexpensive, have low pressure drop when open, and have a reasonably linear control characteristic. However, a simple valve is very noisy with high flows and large pressure drops. One option is to use a quieter valve. Control valve manufacturers offer a variety of globe valves, ball valves, and angle valves that have noise reducing trim. Even with these special valve designs, an unloading silencer is still required to meet typical noise targets. It is generally more economical to use a standard valve and optimize the silencer than it is to use a special valve.

Sound level measurements are generally taken at a distance of 1 m and an angle of 90 degrees from the flow. Silencers have an exhaust jet of hot, fast moving air. The sound level is higher within the jet than to the side of it.

From a noise perspective, usually the best place to locate an unloading silencer is outdoors, above surrounding obstructions, and directed upward. If the silencer is located within a building, the discharge sound will reflect off of the ceiling and walls. The sound level at personnel ear level will be amplified. When the silencer is located outside, adjacent walls and overhead obstructions can have the same effect.

Inclement weather such as snow, ice, or rain can interfere with the operation of a vent silencer. When this is a concern, the supplier can equip the silencer with weather protection.

Inside the pipe, the valve discharge is always very loud. It is important to insulate the pipe walls to minimize this source of noise.

Consult with the silencer designer to optimize the performance.

Some installations use simple low cost notched drain valves for the elimination of condensate from the intercoolers and aftercooler. Figure 12 shows a typical notched drain valve. A notch is cut into the valve to ensure a continuous drainage of condensate. The notched drain valve continuously vents a small amount of compressed air. Depending on the amount of air leakage, high noise levels can be generated by the air flowing through the notched valve.

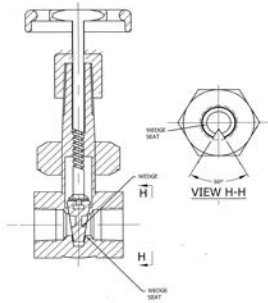

Figure 12. Drain Valve.

To avoid noise generated by the air leakage through the condensate valves, a condensate drainage system using drain traps and liquid level switches can be used as shown in Figure 13. During normal operation the drain trap is closed and there is no noise generation. When the drain trap is activated, the air and condensate passes through an in line muffler (Figure 14).

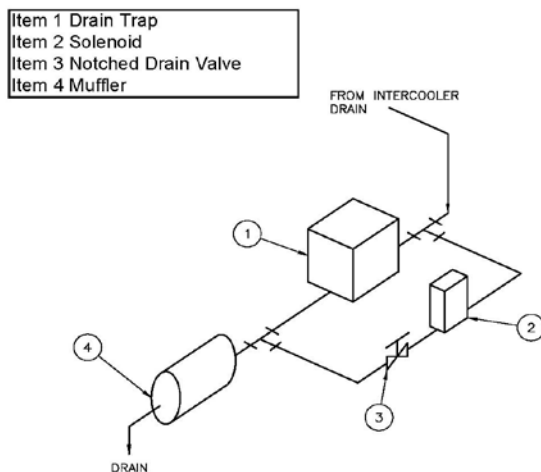

Figure 13. Drain Valve Noise reduction.

For redundancy, the notched drain valve is installed in parallel with the automatic drain trap. In order to operate the bypass system, a level switch is installed inside the compressor intercooler and is interfaced to the solenoid valve. If the condensate level inside the intercooler housing rises as the

result of a drain trap malfunction, the level switch will activate the solenoid valve and exhaust the condensate from the intercooler shell through the notched drain valve. The solenoid valve will remain energized until an operator resets the circuit.

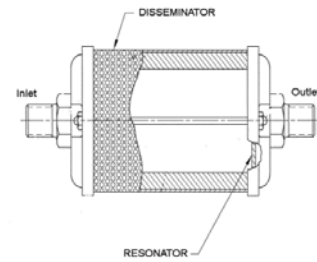

Figure 14. Drain Muffler.

This type of system prevents the continuous noise generation prevalent from the notched valves by only allowing venting when the traps are full. It also provides noise reduction by venting through an in-line muffler. Further noise reduction can be obtained by lagging the piping with proper acoustic lagging techniques.

### Piping

A good reference for acoustically treating inlet and discharge piping and associated valves, expansion joints, and flanges is "ISO 15665: Acoustics - Acoustic insulation for pipes, valves and flanges." This standard covers rigid acoustic piping insulation.

It is best to design and install the piping treatment before the compressor is in place and running. Therefore, the compressor supplier must provide expected octave band frequency data for the compressor piping when operating without any acoustic treatment. The dominant frequency inside of the piping will be the blade passing frequency of the impeller for the stage connected to the piping. Typically this frequency is 1000 Hz or higher.

Once the frequency content and level of the piping noise is known, the required insertion loss of the lagging can be calculated. The insertion loss is the difference in sound pressure level radiated from a noise source before and after the application of acoustic treatment. Table I of ISO 15665 tabulates the different classes of insulation based on their minimum insertion losses for each octave band.

Example: If the maximum permissible sound level is 85 dBA for the piping and the piping noise is 115 dBA, an insertion loss of 30 dBA is required. Based on this overall insertion loss requirement, the class of insulation can be determined from Table I of ISO 15665. The same mathematical procedure described in the inlet filter section is used to determine the overall sound level.

Typical piping insulation is made up of two layers. The first layer is a porous sound absorbing layer typically made from mineral fiber or open-cell flexible plastic foam. The second, outer cladding layer is made from steel, aluminum, plastic or rubber. It provides physical protection to the first layer. For maximum sound attenuation an additional sound barrier layer is added between the porous layer and cladding to

add mass to the cladding. This layer is usually made from a high mass per unit area sheet (barium loaded vinyl) or a visco-elastic polymer damping compound that is sprayed onto the inner side of the cladding.

Figure 15 shows the typical layout of acoustic insulation for a straight piping run. Notice that care must be taken to overlap the cladding both in the vertical and horizontal seams so that no water can enter and there are no leak paths for sound to escape.

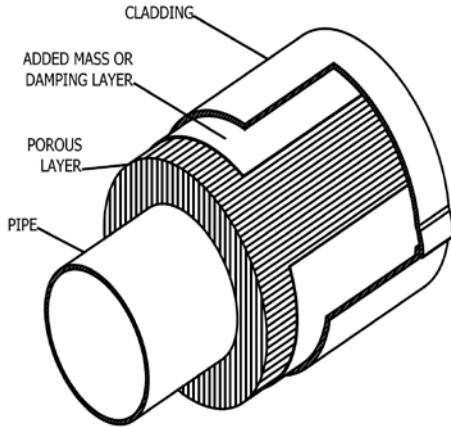

Figure 15. Typical acoustic insulation for piping.

In addition to treating the straight runs of piping all elbows, valves, flanges, and expansion joints should be treated. ISO 15665 provides illustrations of typical installation methods for these components.

It should be noted that piping supports should be insulated from the pipe to where they attach to structural supports. The piping supports should have vibration isolation pads installed to eliminate transmission of noise to structural members as shown in Figure 16.

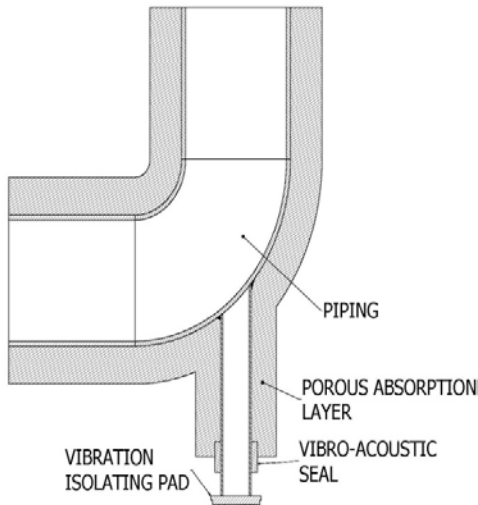

Figure 16. Elbow and piping support example.

Similarly piping hangers should also have vibration isolation pads so that vibrations are not transferred to the supporting structure, which would cause noise.

Walls and Ceiling

Most buildings that house compressors are of steel construction and noise reflection inside of the building amplifies the sound level coming from the compressor. In order to decrease the noise level in the room, this sound reflection must be reduced. The easiest way to accomplish this is through the use of sound absorbing paneling that are attached to the walls, ceiling, and any other reflective surface. Table 2 lists sound absorption coefficients and overall noise reduction coefficients (NRC) for several different foam thicknesses of commercially available foam panels. The sound absorption coefficients for each octave band and overall noise reduction coefficient are scalar representation of the amount of sound energy absorbed upon sound striking a particular surface. A NRC coefficient of 0 is perfect reflection and a coefficient of 1 indicates perfect absorption. NRC coefficients greater than 1 are possible due to the laboratory sample geometry.

The foam panels are installed using an adhesive that is applied with a caulking gun. Also available are cloth covered fiberglass panels (in varying colors) that provide similar noise absorption coefficients. The foam paneling is manufactured in a variety of colors. It can also be painted. Paint will reduce the NRC of the panels. Both the fiberglass and the foam panels can be a challenge to clean.

For maximum noise absorption, all walls adjacent to the compressor, the ceiling and other reflective surfaces should be covered in sound absorbing panels.

Octave Band Center Frequency							
Foam Thickness	125 Hz	250 Hz	500 Hz	1000 Hz	2000 Hz	4000 Hz	Overall NRC
35mm	0.08	0.29	0.73	0.94	0.97	0.89	0.75
53mm	0.17	0.55	1.07	1.15	1.08	1.10	0.85
60mm	0.19	0.62	1.15	1.21	1.14	1.20	1.05

Table 2. Foam octave band noise reduction coefficients.

The price of the absorption material increases with increased thickness. Therefore, it is critical that the octave band frequency content and level is known for the compressor while in operation. Table 3 is an example of typical sound pressure levels of a centrifugal compressor.

Octave Band Center Frequency values in dBA					
125 Hz	250 Hz	500 Hz	1000 Hz	2000 Hz	4000 Hz
64 dBA	74 dBA	78 dBA	89 dBA	91 dBA	90 dBA

Table 3. Compressor Sound Pressure levels in Octave Bands.

Table 3 shows that compressor noise levels are loudest in the octave band frequencies 1000 Hz and higher. Although the 60 mm foam provides the best NRC levels at these frequencies the 53 mm foam has almost equal absorption in these frequencies and would be more cost effective. Figure 17 shows an example of the 53 mm foam installed on a factory wall.





Figure 17. Foam Installation.

### Acoustic Jacketing

Acoustic jacketing is an effective method for reducing centrifugal compressor noise. For maximum sound emission level reduction, the compressor interstage piping, gearbox, and compressor casings should have jacketing installed. Figure 18 shows acoustic jacketing installed on compressor casings, interstage piping and intercooler chamber.

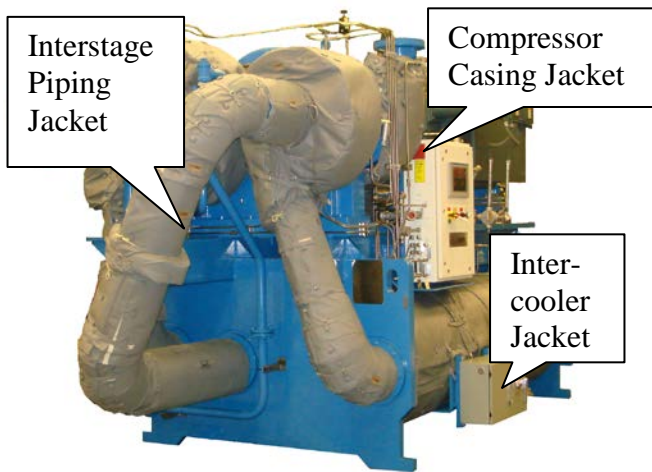

Figure 18. Compressor sound jacketing.

Depending on how intercooler chambers are incorporated into the compressor package, application of acoustic jacketing will reduce the compressor noise. Some compressors use structural tubing construction in the base. Jacketing tubing will often significantly reduce the compressor noise.

Standard acoustic jacketing typically consists of three layers. The first layer (outermost layer) is a Teflon coated fiberglass cloth and it provides excellent chemical, oil, abrasion, and weather resistance.

The next layer is high density mechanically bound fiberglass insulation with a high temperature rating which acts as a sound absorber. See Table 4 for typical sound absorption

coefficients for this layer. The final layer (innermost layer that touches the compressor surfaces) is a silicone impregnated fiberglass cloth which has a continuous temperature rating in excess of 400 F. These layers are double stitched together and held onto the compressor with belts fabricated from the outer jacketing material and attachment rings.

An additional layer of barrier material will provide further noise reduction. This barrier is placed between the outer Teflon coated fiberglass cloth and the fiberglass insulation. It is typically made of Barium loaded vinyl. See Table 5 for typical sound transmission loss for Barium loaded vinyl.

	Octave Band Center Frequency (Hz) vs. Noise Reduction Coefficient					
	250 Hz	500 Hz	1000 Hz	2000 Hz	4000 Hz	Overall NRC
1" Thickness	0.15+/- 0.04	0.60+/- 0.03	1.02+/- 0.02	1.08 +/- 0.02	0.92+/- 0.02	0.070

Table 4. Fiberglass insulation sound absorption coefficients.

Note: The sound absorption coefficients for each octave band and overall noise reduction coefficient (NRC) are scalar representation of the amount of sound energy absorbed upon sound striking a particular surface. A coefficient of 0 is perfect reflection and a coefficient of 1 indicates perfect absorption.

Frequency (Hz)	Octave Band Center Frequency (Hz) vs. Sound Transmission Loss dB						
	125	250	500	1000	2000	4000	STC
Barium Loaded Vinyl	13	17	22	26	32	37	0.070

Table 5. Typical Barium Loaded Vinyl sound transmission loss data.

Note: The values in Table 5 are octave band sound transmission loss values in dB. The sound transmission class (STC) is the overall dB reduction the Barium loaded vinyl would provide in an ideal laboratory setting.

These values are the sound reduction and absorption coefficients in a test environment. If installed perfectly the barium layer alone would provide approximately 26 dBA of overall noise reduction. In practice, when jacketing is used on a compressor the sound reduction will be significantly less. This is due to the fact that there are sound leaks at joints in the jacketing, flanges, air gaps, penetrations, as well as parts of the compressor that are not completely wrapped. With planning and attention to detail, the authors have been able to achieve an insertion loss as high as 15 dBA using acoustic jacketing. However, 6 dBA is a more typical sound reduction.

### CONCLUSION

Centrifugal air compressors can be purchased to meet 85 dBA at one meter without sound enclosures. If good acoustic

practices are not applied during installation of the compressor, the 85 dBA level will not be obtained when the compressor is operating. This often results in disputes between the compressor supplier and the user. Most compressor suppliers rate the noise level for a given compressor model based on the exclusion of system components and in a Free Field environment. System components include process air inlet piping, discharge unloading valve and piping, inlet and exhaust steam piping (when steam turbine driven), inlet filter silencer, discharge unloading silencer, intercooler drain valves, drain lines, vent lines and expansion joints. This paper has presented an overview of best practices for obtaining an installation that will approach the desired sound level for the complete installation.

## NOMENCLATURE

dB	= decibels
dBA	= A Weighted decibels
NRC	= Noise Reduction Coefficient
STC	= Sound Transmission Class
IL	= Insertion Loss

## APPENDIX A

### NOISE MEASUREMENT METHOD

#### *Acoustic Intensity Techniques for In Situ Noise Source Identification*

Measuring the *in situ* sound level in a compressor installation is straightforward. A basic sound level meter can be used to give the overall sound level at each location. This level will be a combination of sound from all sources. Often though, the measurement task is to identify the individual noise sources and to rank their contributions towards the overall sound level.

A variety of techniques have been employed over the years. One of the newer ones uses acoustic intensity measurements. Acoustic intensity can be used several different ways. With the appropriate instrumentation software, it tells the operator the direction towards the source of the dominant sound source. Within the limitations of the measurement instrumentation, it can also be used to determine sound power of equipment *in situ*, even with significant background noise and reverberation.

Acoustic intensity is the sound power per unit area expressed as a vector. The probe is equipped with a pair of phase matched microphones. Signal processing algorithms in the instrument convert the differences between the microphone measurements into acoustic intensity.

The vector property of acoustic intensity can be used for finding dominant noise sources. Intensity measurement systems often have a simple program for operating in "compass mode." The instrument display shows which end of the intensity probe is oriented towards the dominant noise source. Manually rotating and moving the intensity probe allows the operator to quickly identify the dominant noise source at a particular location.

Sound power is the rate of acoustic energy emission from the equipment. Power measurements begin by first constructing a virtual envelope around the machine. The envelope is broken into smaller sub surfaces. Next, intensity measurements are taken on each of the sub surfaces. The emission sound power is calculated for each sub surface as the product between the area and the intensity for each sub surface. The total emission sound power level is the sum of the power levels of each sub surface. Software is available for performing the detailed math of the sound power calculation. Standards such as ISO-9614 provide detailed guidance on the technique.

Sound power can be used to estimate emission sound pressure levels. It can also be used for ranking noise sources. Emission sound pressure levels can be estimated by following ISO-11203.

The first step in acoustic emissions ranking is to measure the sound power level of each noise source. Apply the sound power measurement procedures to all of the noise sources in the area. Be sure to include compressors, valves, inlet filter/silencers, piping, vent silencers, air dryers, or any other auxiliary equipment. Once the measurements have been taken, treat the noise sources with the highest sound power level first.

Acoustic intensity measurements are a helpful tool when evaluating and treating an installation for excess noise emission. The technique can be used for identifying troublesome noise sources as well as ranking the source severity. This information is helpful when creating a sound treatment plan.

## REFERENCES

- Beranek, L.L., 1960, *Noise Reduction*, New York: McGraw-Hill Book Company, Inc.
- ISO 15665: *Acoustics - Acoustic insulation for pipes, valves, and flanges*, Geneva: Switzerland, ISO.
- ISO 1964: *Acoustics – Determination of sound power levels of noise sources using sound intensity*, Geneva: Switzerland, ISO.
- ISO 11203: *Acoustics –Noise emitted by machinery and equipment–Determination of emission sound pressure levels at a work station and at other specified positions form the sound power level*, Geneva: Switzerland, ISO.
- Kensler, K.E., 1962, *Fundamentals of Acoustics*, New York: John Wiley and Sons, Inc.
- Peterson, A. and Gross, F., 1972, *Handbook of Noise Measurement*, Seventh Edition: General Radio.

## ACKNOWLEDGEMENTS

The authors would like to thank Mike Evan, Product Engineer, for his help in obtaining information for this paper. Finally, the authors would like to thank FS-Elliott Company for permission to publish the information presented in this paper.