

Proceedings of the Forty-Second Turbomachinery Symposium
October 1-3, 2013, Houston, Texas

VSDS MOTOR INVERTER DESIGN CONCEPT FOR COMPRESSOR TRAINS AVOIDING INTERHARMONICS IN OPERATING SPEED RANGE AND VERIFICATION

Volker Hütten

Head of Numerical Design Department
Siemens Energy Sector
Duisburg, Germany

Tim Krause

Mechanical Design Engineer
Siemens Energy Sector
Duisburg, Germany

Vijay Anantham Ganesan

Medium Voltage Drive System Consultant
Siemens Industry Sector
Nuremberg, Germany

Christian Beer

Senior E-Drive Expert
Siemens Energy Sector
Erlangen, Germany

Sven Demmig

Medium Voltage Drive System Consultant
Siemens Industry Sector
Nuremberg, Germany



Volker Hütten is head of the Numerical Design department of Siemens Oil & Gas Division, in Duisburg, Germany since 2010. During his more than 21 years in this company he is responsible for the machinery dynamics of compressors and compressor trains of order related tasks. He has been active in correlating analytical results with field data in numerous troubleshooting and problem diagnosis situations.

Volker Hütten received his Diploma degree from the University of applied sciences in Krefeld in 1990.



Sven Demmig is a medium voltage drive system consultant at Siemens Industry Sector in Nuremberg, Germany. After achieving his PhD in the field of electrical drive systems, he has been working for Siemens since 2008.



Vijay Anantham Ganesan is medium voltage drive system consultant at Siemens Industry Sector in Nuremberg, Germany. He received his M.Sc. degree in electrical power engineering from RWTH Aachen University, Germany in 2005. From 2005 to 2010, he was a research assistant at Leibniz University Hannover, Germany.



Christian Beer is a senior e-drive expert at Siemens Oil & Gas Division in Erlangen, Germany. Since 1989 he has specialized in electrical drive systems and has been responsible for LNG e-drive solutions.



Tim Krause is a mechanical engineer at Siemens Oil & Gas Division in Duisburg, Germany, where he is responsible for engineering and troubleshooting of compressor trains in the field of machinery dynamics. He received his diploma degree from the University of applied sciences in Dortmund in 2005.

ABSTRACT

During operation of compressor trains by a variable speed drive system (VSDS), integer and non-integer harmonic currents are generated in the inverter. Via the electrical system of the inverter and the motor, an excitation torque is transferred across the motor air gap into the main mass of the motor rotor. The frequency of this excitation may cause torsional resonances. Due to the rapid increase in excitation frequency of integer harmonics, intersections with relevant torsional natural frequencies (TNFs) can in general be avoided within the operating speed range. In contrast, the intersections of the non-integer harmonic excitation frequencies, also called interharmonics, with TNFs within the operating speed range may have an essential impact on the vibration behaviour of the rotating equipment. This aspect has to differentiate between two train configurations. The first are direct driven trains and

the second, trains including an intermediate gear. For direct driven trains, only fatigue problems have to be considered. In trains with an intermediate gear, on top of that, interaction of torsional and lateral movement may have a negative effect on the lateral vibration behaviour of the gear rotors.

The main focus of this publication is on a simple but effective method for turbo compressor applications that allows avoiding main resonances within the operating speed range caused by intersections of interharmonic excitations with relevant TNFs. This method is based on detailed knowledge of the inverter behaviour and possible design options of the motor itself. This in-depth understanding was developed by correlating numerical and experimental results based on dynamic torque measurements of real turbo compressor trains. During this investigation the mechanically relevant torsional excitations were identified. Therefore, the different types of inverters and their corresponding characteristics had to be analyzed and understood in detail. This knowledge, in combination with possible motor designs, with regard to the number of pole pairs and the most common train configurations (direct driven and/or trains including intermediate gears), is incorporated in this report.

INTRODUCTION

Advantages of VSIDS Driven Trains

Rotating equipment in the turbomachinery industry traditionally uses mechanical drivers as prime movers. Process and mechanical engineers have confidence in their equipment and might have reservations about yet not installed electrical equipment. Ongoing discussions about energy efficiency, equipment availability, operability and avoidance of green house gas emissions (GHG) has lead to a steadily increasing use of electric motors, either as fixed speed or as variable speed drivers. The industry has reacted with an array of electrical drive systems that can beneficially replace gas turbines and gas engines as prime movers of compressors and pumps.

In smaller power ratings the electric motor is unchallenged in all industrial fields, including the oil & gas industry. Its simplicity, robustness, and performance is unmatched by any other drive in most all applications. In Megawatt power ratings, however, electric motors are challenged by gas turbines. Detailed driver selection studies are the rule when it comes to find the best suited driver for a given application. With the introduction of electronic variable speed drives in the late '70s to the industry the benefits of fixed speed electric motor drives have been significantly enhanced and these additional features are most often the reason for their selection:

- Soft start and fully torque controlled operation over a wide speed range
- Dynamic & accurate speed control via electronic variable speed controllers
- Ability to ride through brief power bus disturbances
- Energy efficiency above 95 percent also in part-load mode and related speed range
- Shaft speeds in excess of the customary 3000 or 3600 rpm dictated by the power system frequency, eliminating step-up gears in many cases

- Insensitivity to frequent start/stop cycles and ability to (re)start fully loaded compressors
- Instantaneous starting capability provides process flexibility
- Lower in GHG and noise emissions

Suppliers of such motors and many engineering contractors have the experience, know-how, and tools to select and recommend the optimum variable speed drive system for a given application.

History

After the technology's potential to realize variable speed operating envelopes in combination with high efficient electric drives was discovered, it was installed more frequently. However, it turned out that the ecologic and economic advantages of all-electric compression with VSIDS driven trains come along with a technical issue to solve.

For many years occasionally high lateral vibration in intermediate gears as well as coupling or shaft end damage occurred and was reported to the industry (Corcoran, et al., 2010), (Kita, et al., 2008), (Kocur and Corcoran, 2008), (Naldi, et al., 2008), (de la Roche and Howes, 2005), (Feese and Maxfield, 2008). Measurements revealed high torque oscillation amplitudes, initially caused by torque oscillations generated in the inverter. These travelled across the motor air gap towards the rotating equipment and excited the fundamental TNF of the entire train.

Variable speed drive systems rectify alternating line current (AC) of 50 Hz and/or 60 Hz, to direct current (DC), and invert the DC to a variable frequency AC current in order to operate the motor at variable speeds. As illustrated in Figure 1 the electrical conversion from line side to the motor side, quite small harmonic distortion of the inverter output current causes forced torsional vibration. Due to small amplitudes, this is outside the resonances of a well enduring load for the train components. Unfortunately, the vibration is amplified when the excitation frequency of torque ripples match a TNF with a suitable mode shape to excite the train. These can then be high enough to either transfer the torsional vibration energy into lateral pinion vibration through the gear, or even exceed the component's fatigue lifetime capacity.

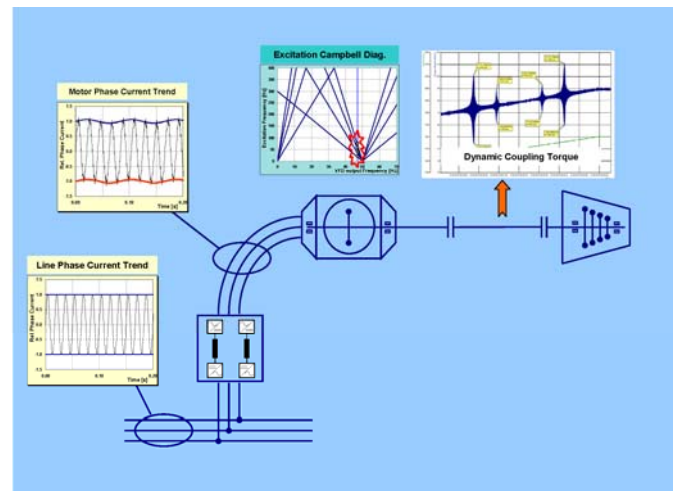

Figure 1. Electro-Mechanical Interaction.

The turbocompressor manufacturers historically dealt mainly with torsionally easy to handle gas and steam turbine drives and fixed-speed electric motors. They now had to close the ranks with the electric drive equipment manufacturers to gain ground in bringing the two disciplines, electrical and mechanical engineering, together.

Technical Impact of Torsional Resonances Excited by VSDS

In principle, generated harmonic torque oscillations may have an essential impact on the torsional vibration behavior of the entire train. Consequently, the train-responsible party, mostly the compressor manufacturer, must carry out detailed analyses to examine the operational condition of the rotating equipment in order to do a proper engineering design. Therefore, close collaboration of driver and compressor manufacturer in designing and engineering of such a VSDS-driven train is essential, as also stated by Hudson (1992).

First of all, it is an essential task to avoid fatigue in the torque-transmitting elements. Torsional excitation may cause fatigue which could eventually lead to a catastrophic failure of torque transmitting elements. During the engineering phase of any project the occurring peak torque and the corresponding torque capability of each individual train component has to be evaluated. Furthermore, in systems including intermediate gears, elevated lateral vibration of the pinion and bull-gear rotors could also occur. Due to the fact that torsional and lateral vibrations are coupled via the gear mesh, excitations have to be examined to avoid higher lateral amplitudes and/or to avoid clattering in gears in addition to fatigue problems.

Based on the authors' experience, excessive high lateral vibrations caused by a torsional excitation were observed in some cases. It is due to the coupled movement in lateral and torsional direction, a more or less plausible behaviour. Nevertheless, the authors have, in some cases, also observed high torsional vibration amplitudes and, simultaneously, only few microns of relative shaft vibration corresponding to the torsional excitation frequency.

A case of white noise excitation in contrast to the widely known single frequency excitation has not yet been encountered by the authors. However, two cases of VFD compressor trains in the LNG industry showing such phenomenon were recently published (Kocur and Muench, 2011).

Ultimately, only a dynamic torque measurement during string testing and/or during commissioning would be able to identify the potential risk of a failure. The alternative is to have a reliable strategy for the engineering. One specific will be presented as the main topic of this paper, but also other options will be discussed which positively influence the aspects.

GENERATION OF TORQUE RIPPLES IN VSDS

Principle of Generation of Torque Ripples

The motor air gap torque is generated by the rotor flux in combination with the stator current. For a perfect sinusoidal stator current waveform and a perfect air gap field, the motor torque would be constant. Using a VFD, the motor current waveform is not perfectly sinusoidal. The AC-DC-AC

conversion adds torsional excitation frequencies to the system. Integer harmonics and interharmonics excitation generated in the converter cause torque oscillations in the motor air-gap. This effect cannot be disregarded due to the fact that interharmonic excitations can be of such frequency that they can generate torsional resonances in the operating speed range.

The air gap torque ripple generated by the VFD characteristic can be split in two categories (Figure 2):

- Integer harmonic torque excitation
- Interharmonic torque excitation

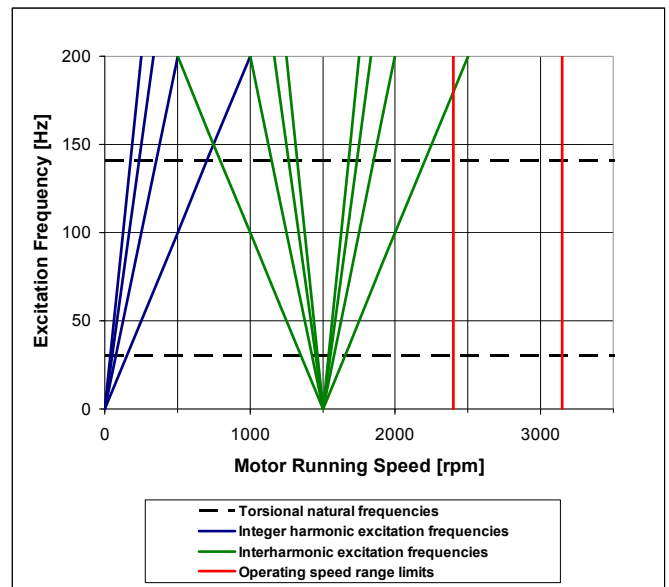

Figure 2. Typical VFD Campbell Diagram.

The excitation frequencies are written for the integer harmonic torque harmonics as $f_{exc-h} = C_1 * f_{do}$ and for the interharmonics as $f_{exc-i} = |(C_2 * f_{do} - C_3 * f_i)|$.

The integer harmonics are directly proportional to the motor stator current frequency and therefore the motor speed. The characteristics depend on the converter topology e.g. VSI or LCI and the pulse number of the motor side rectifier. The amplitude of the air gap torque ripple depends, just to mention the main factors, on:

- Switching device characteristic
- Motor impedance
- Motor voltage
- Motor cable characteristic
- PWM characteristic for VSI drives

The non-integer harmonics are caused by the not perfect DC current (LCI drives) or DC-voltage (VSI drives). This means the characteristic of the line side inverter is modulated on the motor currents by the motor side rectifier. Because of this modulation, the frequency of the interharmonics depends on the line frequency, the motor frequency and the pulse number of the motor and the line side rectifier. The amplitude is influenced by the same parameters as the integer harmonics plus additional parameters of the DC-link and the line side:

- DC-link capacitance / inductance

- Line side characteristic (harmonic pre-load, frequency-dependant impedance, etc.)
- Transformer impedance

The resulting torque ripple frequency of the interharmonic air gap torque varies within the range of operation depending on the parameters explained before. Nevertheless, this may result in an interaction with the TNF of the mechanical string even if the amplitude is much lower than the amplitude of the integer harmonics.

Because of the large number of parameters influencing the amplitude of the air gap torque ripple the prediction of specific amplitude is complicated and only possible with tolerances. But knowing the drive and motor type the torque ripple frequencies over the complete speed range can be predicted easily even without any simulation.

It has to be pointed out that this kind of behaviour is inherent to all state of the art inverters in the entire market. It varies only with regard to interharmonic frequencies and excitation magnitude for each particular configuration.

Typical Motor Design and Number of Pole Pairs

Electrical motors can be built in 2, 4, 6, ... pole design (equivalent to number of pole pairs (N_{pp}) of 1, 2, 3, ...) and this leads to synchronous speed of:

$$n_{syn} = (f_i / N_{pp}) * 60 \quad (1)$$

As can be seen in Figure 3 a motor with a number of pole pairs of 1 runs with supply frequency. Whereas a motor with a number of pole pairs of 2 at half and with a number of pole pairs of 3 at one third of the supply frequency accordingly. This is an essential fact in order to find resonance free train design solutions within this new design concept.

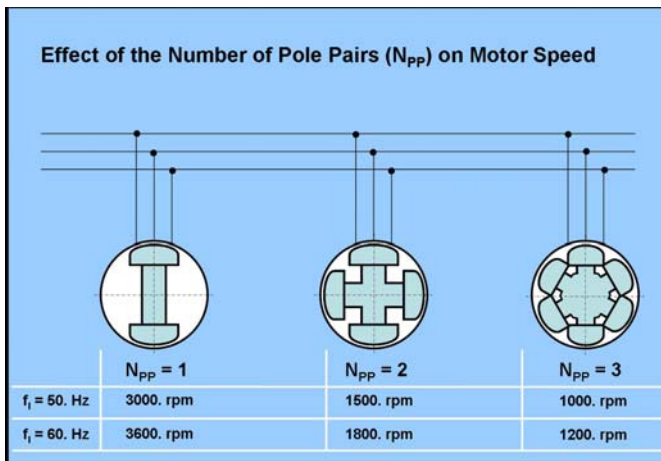

Figure 3. Effect of Number of Pole Pairs on Motor Speed

Overview of Relevant Frequency Converter Types

In the turbomachinery industry 2 frequency converter types are typically used:

- Voltage source inverter (VSI)
- Load commutated inverter (LCI)

Both types have specific advantages and disadvantages and the selection is based on power and voltage range, complexity

and the reference situation. In general VSI are used for the lower power ratings up to 25 MW and the LCI is the preferred solution for the highest power ratings up to 120 MW. In the range of 15 to 25 MW both topologies can be used. The VSI can be used with all motor types and topologies with different pulse numbers. The VSI will generate motor voltage in block form. The resulting motor current depends on the stator inductance, the cable parameter, the pulse number and the control characteristic. Nevertheless, the current total harmonic distortion (THD) of VSI drives is lower than the current THD of LCI drives. As explained before, this leads to a lower torque ripple which may be advantageous for the overall compressor string design.

The LCI instead can be used for synchronous motors only. Also for the LCI topologies, different pulse numbers are available. The motor current is generated in a block form, results finally in higher current THD.

EXPERIENCE WITH AND CONSEQUENCES OF INTERHARMONIC EXCITATION

Several case studies of vibration issues related to torque excitation caused by inverter fed motors have already been published. Here, two of our own typical examples of case studies are presented which were used in order to get an in-depth understanding of the operating behaviour of the individual inverter types. This information is needed to realize the new train design concept that is lastly the main focus of this publication.

Excitation Pattern of a VSI

In the first case, a 1.5 MW 12-pulse VSI inverter feeds the induction motor of a single-shaft radial compressor train with intermediate gear. During run-up with constant acceleration the dynamic torque measurement at low speed coupling recorded amplitudes as shown in Figure 4. As the inverter speed control actively accelerates the train, the harmonic and interharmonic excitation lead to dynamic torque peaks at speeds, where torsional resonance occurs. The blue line is the torque measurement and the green line shows the motor speed, both versus time. Some torque peaks can be observed: one single major amplitude at about 2700 rpm and some peaks quite close together especially in the low speed range.

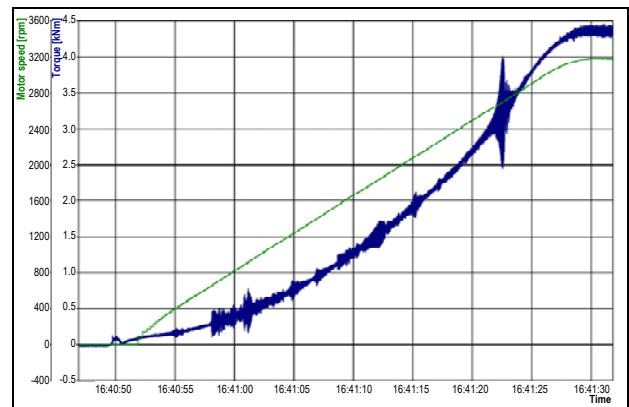

Figure 4. Trend of Motor Speed and Dynamic Torque at Low Speed Coupling.

It is practical to plot these together with the TNFs and excitation frequencies in a Campbell diagram. Figure 5 represents this diagram with the first two TNFs (dashed lines) and torque ripple excitation frequencies (solid blue lines) versus motor operating speed. At motor speeds where the 1st TNF and excitation frequency intersect, a resonance is present. The red circles indicate the relevant resonances.

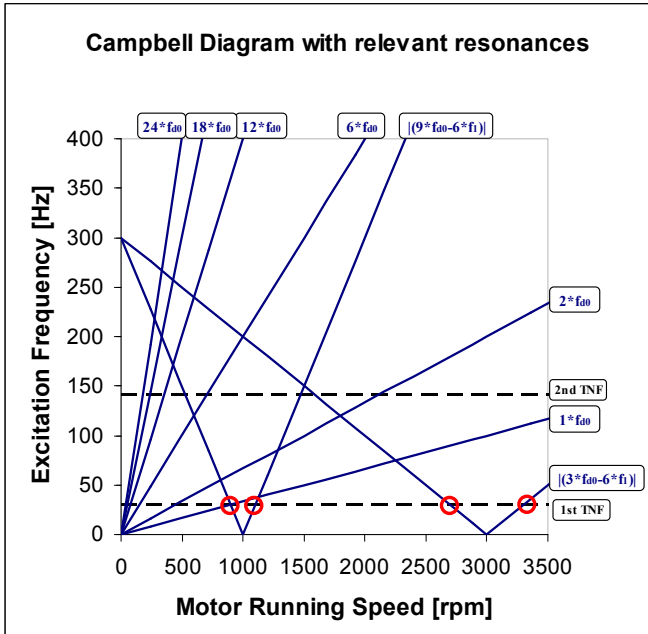

Figure 5. Campbell Diagram with Relevant Resonances.

The diagram reveals that the by far dominating torque peak at 2700 rpm is caused by the $|3*f_{do}-6*f_i|$ interharmonic excitation frequency exciting the 1st TNF. This excitation should therefore, as major resonance, not fall within the operating speed range. Apart from this, secondary amplitudes at about 10 percent peak-to-peak the motor rated torque are observed. The first natural frequency is stimulated by the $|9*f_{do}-6*f_i|$ interharmonic excitation frequency and $1*f_{do}$ at about 900 rpm. Due to its mode shape, the first natural frequency for this train configuration commonly leads to the highest torque amplification for excitation at the motor air gap. Torque amplitudes at other speeds, due to their limited amount, are considered not relevant for the train design. These results leveraged the confidence to use the numerically derived excitation frequencies for this inverter type for the later described train design concept.

Excitation Pattern of a LCI

The following example is related to a 16 MW 12-pulse LCI driven synchronous motor train, connected to a 50 Hz grid, including intermediate gear and a single shaft radial compressor. The train has been designed to operate in a speed range of 1260 rpm to 1890 rpm. In order to get the required information with regard to relevant interharmonic excitation the train was equipped temporarily with strain gauges at the low speed coupling for a dynamic torque measurement. During the measurement program the train was ramped-up slowly with an acceleration rate of 0.2 up to 0.5 rpm per second. The measured

dynamic torque (blue line) and the motor speed (green line) are shown versus time in Figure 6. Four main torsional resonances could be observed. These resonances correlate with the fundamental TNF and the expected interharmonic torque excitation of the 6- and 12-order. Based on that result, it means that higher orders of interharmonic excitations are not relevant regarding torsional excitation within this system.

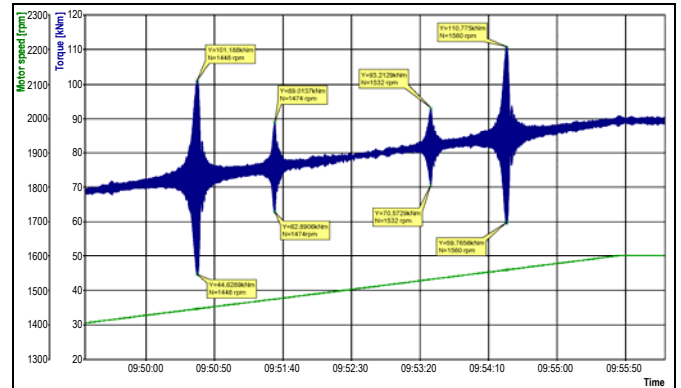

Figure 6. Ramp up of 16 MW LCI Driven Train.

In the next step it is essential to know what happens to the torque amplitude by running in resonance conditions. In order to get an understanding of the behaviour of the vibration system each individually observed resonance was entered for a period of time. For one example of these tests see Figure 7. The observed torque amplitude was generally higher during continuous operation in contrast to crossing the resonance. However, the maximum torque amplitude achieved stationary conditions. This information is of paramount importance with regard to a worst case operating scenario of the fatigue design of the train components running in resonance condition permanently.

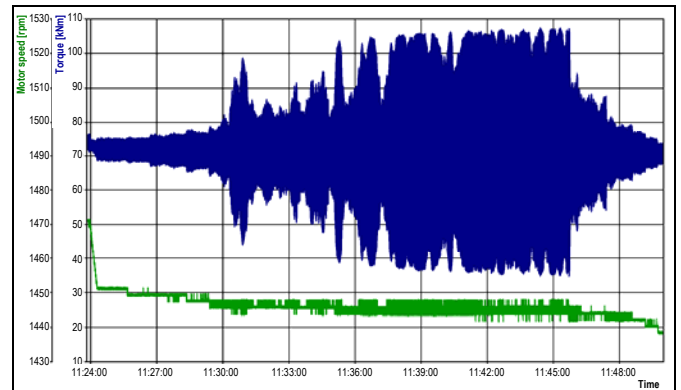

Figure 7. Stationary Operation in Resonance of 16 MW LCI Driven Train.

For this particular case, the measured torque amplitudes at torsional resonance condition were above the expected, based on the state of the art electro-mechanical simulation. Nevertheless, the applied service factors considering the simulation uncertainties ensure that the mechanical train components are capable of withstanding the observed dynamic torque amplitudes permanently. Therefore, the train can be operated without any operational restrictions.

Comparison of Simulated and Measured Results

Several VSIDS driven trains were investigated on a numerical basis. For some of them, measured results of dynamic torques are available for correlation. The analytical investigation is generally able to identify the relevant interharmonic excitations. The TNF and the corresponding motor speed can be determined with satisfactory accuracy. But nevertheless, based on the authors experience of correlating results of various simulated and observed torsional turbomachinery systems, the peak torque amplitude in the state of resonance condition cannot be predicted with sufficient accuracy in order to carry out a fatigue analysis on a numerical basis only. Therefore, it can be concluded that further uncertainties exist in the electrical and also in the mechanical model. To compensate for these uncertainties the service factors are conservatively selected. This guarantees safe design while accepting the drawback of over-engineering. For an accurate prediction of the occurring dynamic torque in the train elements, the magnitude of torque excitations including realistic tolerances are essential. Further investigations and improvements of the electro-mechanical simulation model are of course an ongoing task.

Experience with Interaction of Torsional and Lateral Vibrations

For trains including an intermediate gear and/or for trains with an integrally geared type compressor, the torsional and lateral vibration system are coupled in movement via the gear mesh. In such a case, the lateral vibration spectrum may also present frequency components of the torsional excitation frequency.

Higher lateral vibrations were observed in the field with trains featuring gears. This kind of observation is not only reflected by the authors' experience, but is also published in other literature sources (Kita, et al., 2008), (Naldi, et al., 2008).

At a first glance it seems to be plausible that high torque fluctuation also produces high lateral vibrations. This is the reason why only concerns regarding high dynamic torques are raised, when high lateral gear shaft vibrations are also evident. In contrast, cases could also be observed where high torque fluctuations were measured, although only insignificant lateral vibrations of the gear pinion and/or the bull gear could be seen. Having the physical relationships in mind, this issue boils down to the influence of the dynamic oil film stiffness of the gear bearings.

Generalized, one can only conclude that if TNFs can be measured in the lateral vibration spectrum, dynamic torque oscillation will with high probability be present in the train. However, low levels of radial vibrations do not necessarily mean low levels of dynamic torque fluctuation in the train components.

White noise excitation

Harmonic, inter-harmonic and control loop torque disturbances form the group of single frequency excitation mechanisms. These are widely considered the main issue related to VFD's, but recently two cases of VFD compressor

train torsional vibration were published, which were connected with white noise excitation (Kocur and Muench, 2011). This made it necessary for the involved parties to rethink the strategy for torsional analysis, including the system response to banded Gaussian white noise into the scope. The authors cannot give recommendation in this matter, since they have never experienced a case of torsional vibration related to white noise, simulated or practical, with their equipment so far.

CONVENTIONAL STRATEGIES OF DEALING WITH INTERHARMONIC EXCITATION

If a resonance with an interharmonic excitation is detected and countermeasures are found to be necessary, one can today choose from a wide range of proven alternatives. These can be sorted into one of the following categories:

- Damping increase
- Excitation reduction
- Torque transmitting component fatigue capability increase
- Resonance avoidance

What follows, they are presented and discussed with their inherent advantages and disadvantages to give an overview.

Inverter Control Setup

Although the basic root cause was not exactly the same in all of the case study papers mentioned in the introduction, for all of these cases modifications of the setup of the inverter control or inverter control type change finally reduced the excitation torque amplitudes sufficiently. De la Roche and Howes (2005) describe the case of a motor driven reciprocating compressor with motor shaft failure on one of two trains. For the first train, inverter software parameter change was able to increase, as well as satisfyingly decrease the torque oscillations. They and Corcoran and Kocur (2008) as well, mention the speed feedback into the inverter control to be a contributing factor to the overall vibration. It is considered able to amplify the oscillation, when the speed control counteracts the speed fluctuation initiated by the torsional vibration.

When torsional vibration is present, it is adequate to first exhaust the remaining room for improvement in the inverter control for optimization.

Designing Components Robust Enough to Withstand Torque Ripples

According to the applicable paragraphs of API617 7th edition, if excitation mechanisms are known to act in a compressor train, the train responsible party shall conduct a stress analysis. This shall show permissible amplitudes compared to high cycle fatigue capabilities of the train components. It would be therefore satisfying to design the relevant train components in such a way that they can withstand the occurring dynamic torsional load over the train's lifetime. The benefit for the operator is that the train can be operated with the whole speed range specified, although resonances are present only at certain speeds.

Necessarily, the dynamic torque amplitude must be known from torque measurement records, or it must be sufficiently and

accurately predicted by torsional analysis. Independently, whether the simulation model is a harmonic forced response simulation or a coupled electrical/mechanical simulation, both deliver the dynamic torque response within the train elements of interest at the detected resonant conditions. These results vitally depend on the damping assumption made in the analysis and the accuracy of the expected dynamic air gap torque excitation magnitude. If uncertainties regarding the above aspects are present, service factors need to be conservatively defined. From the authors' point of view, there is still some need for refinement of simulation models. It promises for the future service factors to be reduced to appropriate figures, thus preventing over engineering.

Individual Exclusion Speed Ranges at Resonance Condition

The torsional resonances described before can also be avoided by using individual exclusion ranges. It is practicable to determine resonances of relevance, i.e. with a dynamic torque amplitude probable to exceed a component's high cycle fatigue capability, by torque measurement at the manufacturers test bed facilities or during commissioning. The countermeasure is then to implement the identified resonant motor speeds into the inverter speed control. These speeds plus a separation margin including tolerances and uncertainties are blocked. It is by this, of course, not possible to exclude resonances from the speed range, but it limits the time of operation within to a minimum. In a variable speed performance map, blocked speed ranges can be illustrated as the areas shown in Figure 8. It must be clear that for the plant operator, a blocked speed range, even if it is small, always is a limitation of production flexibility.

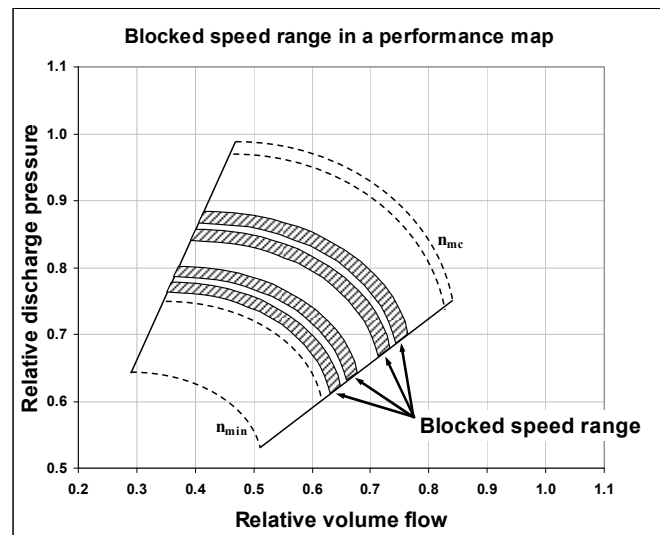

Figure 8. Blocked Speed Ranges in a Performance Map.

Using individual exclusion ranges seems to be a simple and effective solution. However, a lot of parameters and uncertainties have to be born in mind by setting the real problem solving exclusion speed ranges.

For one single train installed, these include the accuracy of the dynamic torque measurement itself, changing of material properties over life cycle and/ or due to temperature and local grid frequency variation, just to name few. The last parameter

can, especially in countries with high grid frequency fluctuation, become the decisive parameter for the blocked speed range. It would necessarily increase, unless the grid frequency was considered in a speed control algorithm as an additional parameter, which is possible.

In case of multiple identical trains installed, efforts increase. If a torsional measurement is going to be done for one train only, it should be critically discussed, how material property uncertainties between the train components are reflected in the determination of the blocked speed range(s).

Damping in Control Loop

Active damping of the load or the process using the VFD is standard in some industries. Also for compressor strings there are approaches to use the VFD for active damping (Naldi, et al., 2008). The challenge for the compressor trains is the low frequency of the switching devices and the limits of the specific topologies. Another challenge is the identification of the train characteristic. The control loop needs as input parameter the actual status of the train. Therefore, additional sensors are most likely needed.

The conventional multi parameter control system of an inverter is extended by an additional damping control loop. This feature should be considered in detail during engineering and also during the commissioning process in order to achieve a reliable operation. As long as additional sensors need to be installed and are crucial for the functionality, redundancy is essential.

Damper Coupling using Elastomeric Elements

Occurring torque response in resonance condition is mainly determined by the magnitude of the torque excitation and the mechanical amplification. Therefore, torsional damping is a significant influence parameter for the overall system. Couplings consisting of a steel structure combined with integrated elastomeric elements are used as common dampening device. The main task of these elastomeric elements is to absorb torsional vibration energy by compressed deformation of the elements in contrast to solid steel couplings. It is of utmost importance that this coupling be located close to the node of the mode shape of the fundamental TNF to be most effective in increasing system damping. As a consequence of the material properties, the rubber elements degrade over time due to heating up and environmental factors. The main disadvantage of this kind of coupling is usually increased maintenance for reliable operation, in contrast to solid steel couplings. Due to this fact elastomeric couplings are principally not allowed per specification of the operators for some applications.

The authors are convinced that using such kind of coupling may help to limit the torque amplitude during crossing resonances for a short period of time. However, for VSIDS driven trains it may happen that the train is running in condition of a torsional resonance for a longer period. If amplitudes are excessively high, running in resonance condition for a longer period may overload the elastomeric elements. Coupling failure in a VSIDS driven train are, in most cases, not necessarily caused by a poor coupling capability, but are quite often caused

by the train behaviour itself (Corcoran and Kocur, 2008).

NEW TRAIN DESIGN CONCEPT TO AVOID INTERHARMONICS IN OPERATING SPEED RANGE

Basis of the New Train Design Concept

In principle, the basis of the new train design concept to avoid interharmonics within the operating speed range is an in-depth understanding of inverter behavior, motor design and finally, the various compressor train configurations and their corresponding torsional behavior. First of all, it is essential to work out the details of the mechanically relevant torsional excitations caused by the individual inverter types. This task has been done on a numerical basis by simulating the electrical and mechanical system. Due to the fact that the occurring torque amplitude in a state of resonance condition is connected with tolerances, although using state-of-the-art coupled electrical and mechanical simulation models, correlation with dynamic torque measurements are of vital importance. This is to separate the relevant excitation frequencies from the insignificant. In the next step, possible motor designs of induction motors and/or synchronous motors with regard to different numbers of pole pairs have to be considered. Lastly, the engineering process of the motor manufacturer itself should enable the flexibility to adapt the required operating speed range for the individual application in order to avoid the relevant torsional excitations within the operating speed range of the driver. The new train design concept will be presented on an exemplified basis for a current source inverter in the following chapter.

Introduction of the Design Concept on Basis of a Current Source Inverter (LCI)

To explain the developed design concept in order to avoid interharmonic excitations caused by the inverter within the operating speed range, a compressor train direct driven by a synchronous motor fed by a 12-pulse LCI is considered. On the basis of numerical investigations, the 6-pulse and 12-pulse current source inverter generates the following interharmonic excitations:

$$\begin{aligned} &|6*(f_{do}-f_i)| \\ &|12*(f_{do}-f_i)| \\ &|18*(f_{do}-f_i)| \\ &|24*(f_{do}-f_i)| \end{aligned}$$

The main difference in characteristics for a 6- and 12-pulse design is related to torsional excitation magnitude only. Typically the higher the number of pulses the lower the excitation magnitude.

For these types of inverter 6-, 12-, 18-, 24- and 36-pulse designs are currently being used in the field of compressor train applications. In order to consider all these inverter types, the mechanically relevant harmonic and interharmonic excitations have to be identified out of the known multitudinous theoretical excitation potentials.

Identification of the Relevant Interharmonic Excitations of a 12-pulse LCI

By numerical investigations of various types of inverter, numerous harmonic and interharmonic excitations can be identified. In order to identify the VSDS generated mechanical relevant excitations, dynamic torque measurements are indispensable. As described in chapter *Excitation Pattern of a LCI*, torsional resonance conditions of a 12-pulse LCI driven train could be observed. The measured resonances and its corresponding motor speeds can be projected into a Campbell diagram in order to identify the relevant excitations as can be seen in Figure 9. Based on these results, it is obvious that for this particular inverter only 6- and 12-order interharmonics are of relevance with regard to mechanical excitation of the torsional system. Therefore, only these excitations have to be considered in the train design concept.

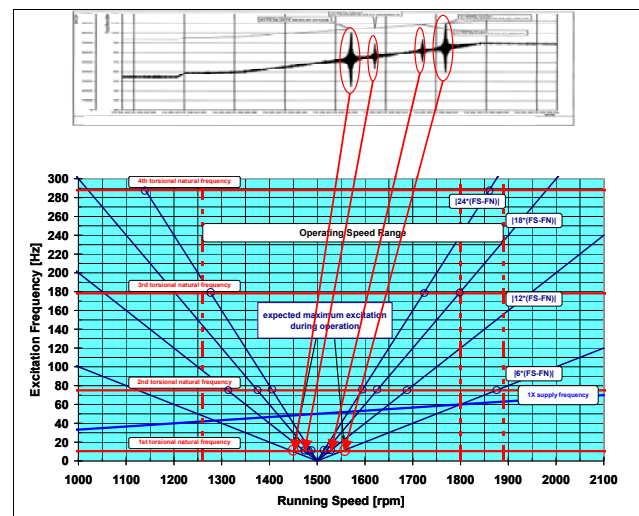

Figure 9. 12-pulse Current Source Inverter (LCI).

In the next developing step of the strategy, the mechanically relevant harmonic and interharmonic excitations can be presented in a Campbell diagram as seen in Figure 10. The excitation frequency is presented on the vertical axis whereas the motor supply frequency is shown on the horizontal axis of this diagram. The incorporated harmonic excitation lines are of 12, 18, 24 and 36 times of motor supply frequency. The presented characteristic of the interharmonic excitation lines are as has already been described. Typically, all these interharmonics intersect the horizontal axis at grid frequency (for this example 50 Hz). The frequencies are considered as absolute values. Therefore, the excitation lines are given as V-lines in a Campbell diagram. The intersections of the excitation lines of the above mentioned interharmonics and the TNF range are all in immediate vicinity. All excitation lines are incorporated into the diagram, although we have learned that only the 6- and 12-order interharmonics are of mechanical relevance. However, due to the fact that a separation margin of 10 percent as specified in the API617 has to be considered, the higher order interharmonic do not effect the required exclusion range.

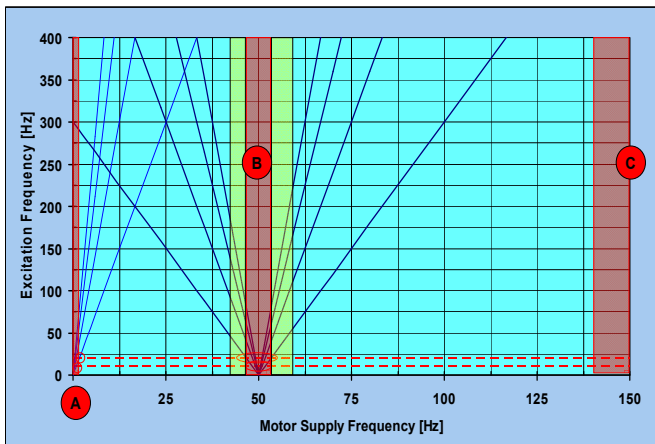

Figure 10. Campbell Diagram of a 12-pulse LCI Driven Compression Train.

In a next step the typical fundamental TNF range has to be identified based on experience. For this particular example a range of 10 to 20 Hz for the fundamental TNF has been considered. Most train configurations within the authors references are within this range and/or could be moved into this range by tuning the coupling stiffness, given that some kind of mechanical necessity is present. For conventional train configurations like direct driven trains (motor-compressor) and/or trains including an intermediate gear (motor-gear-compressor), the first TNF can be significantly excited at motor main mass due to the corresponding torsional mode shape. It has to be pointed out that for train configurations considering a drive through motor, also the second and /or the third torsional critical speed could be of vital importance. It has to be checked individually.

The intersections of the mechanically relevant excitations and the range of TNFs can easily be identified. Therefore, exclusion ranges can be set at these ranges of motor supply frequencies. To make it obvious, exclusion ranges are generally marked in red in the following figures. The first exclusion range (A) at lowest supply frequencies is related to the harmonic excitations. In order to avoid resonances with the interharmonic excitations the second exclusion range (B) has to be set. These excitations are located in the immediate vicinity of the grid frequency. In compliance with the requirements of API617, an additional separation margin of 10 percent is considered for the exclusion ranges (A) and (B). Whereas the first exclusion range is typically not relevant for continuous turbo compressor operation, the second exclusion range (B) could be in conflict with the operating speed range. Based on this graphic presentation it becomes obvious that the interharmonic excitations are of technically higher importance. The third range (C), also marked in red, is determined by the individual maximum supply frequency of this particular application which can be generated in the inverter. That means, it describes the current frequency limit of the inverter for standard applications.

Based on these considerations, the supply frequency ranges which should be avoided are separated. In addition, the ranges of motor supply frequency without resonances caused by inverter operation are identified. Therefore, these are the supply frequency ranges which should be used for designing compressor trains.

In order to design compressor trains, it is at this stage necessary to transfer the driver supply frequencies into a motor speed related diagram. Transferring electrical supply frequencies into mechanical running speeds of a motor means that the number of pole pairs of the motor has to be considered. The impact with regard to allowable or excluded motor speed ranges is clearly presented by Figure 11.

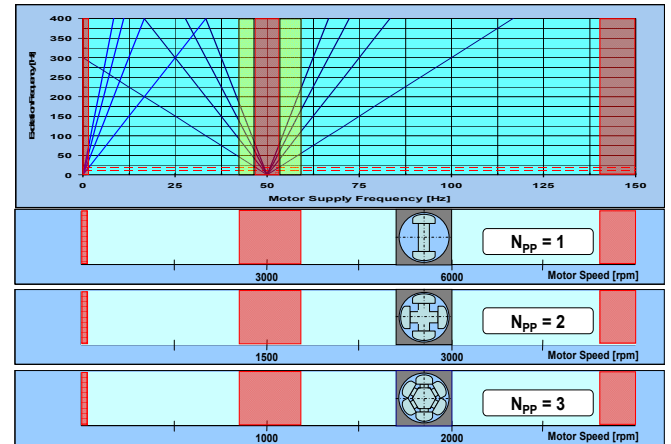

Figure 11. Exclusion Ranges Transferred into Motor Speeds.

The well known relation between operating speed and inverter supply frequency and number of pole pairs of a motor is defined as follows:

$$n_{op} = (f_{do} / N_{pp}) * 60 \quad (2)$$

The determined exclusion ranges are transferred into a motor speed related diagram for the chiefly used number of pole pairs 1, 2 and 3. Focused on the most relevant exclusion range of the resonance conditions caused by interharmonics, it becomes obvious that the center of the most important exclusion range shifts from 3000 rpm to 1500 rpm and finally to 1000 rpm for a number of pole pairs of 1, 2 or 3, accordingly. In order to consider this information during the proposal and/or execution phase of a project, the information has to be transferred into a motor speed related bar diagram as can be seen in Figure 12. For achieving a reliable engineering process, a more or less simple illustration of the complex background information is essential.

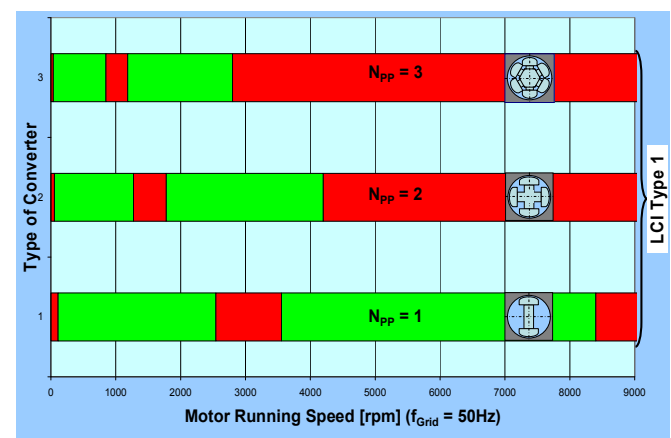

Figure 12. Bar Diagram of Motor Speeds for 12-pulse LCI.

Figure 12 collects all the relevant information in order to

avoid torsional resonances caused by a 12-pulse LCI operation. The allowable speed ranges are marked in green, whereas motor speeds which should be excluded are marked in red. It goes without saying that additional separation margins have to be considered to achieve a trouble free operation with regard to torsional excitation mechanisms, for example running speed related excitations as specified in API617. Based on this illustration, it becomes obvious that theoretically for all common used driver speed ranges solutions can be realized.

Consideration of Direct Driven Trains

A typical train configuration of a direct motor driven turbo compressor is shown in Figure 13. For this particular example a large synchronous motor and a barrel type compressor are coupled via a diaphragm coupling.

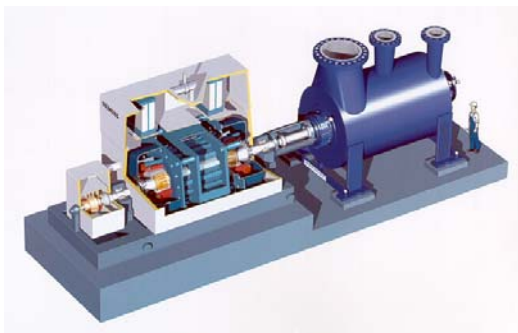

Figure 13. Typical Direct Driven Compressor Train.

For the design process of such compressors, the typical application range with regard to compressor speed has to be considered. For larger direct driven centrifugal compressors the minimum operating speed could be at about 2000 rpm whereas for smaller direct driven compressors the maximum operating speed can be significantly higher, up to 8000 rpm and even higher for special applications. For direct driven trains, speed ranges between approx. 2000 and 4000 rpm can be realized by a load commutated inverter in combination with a driver considering a number of pole pairs of 2 as illustrated in Figure 14. Such a train design would be able to avoid main torsional resonances within operating speed range. Currently a 4-pole motor ($N_{pp}=2$) operated at frequencies higher than 60 Hz represents an uncommon design in the turbomachinery industry. Nevertheless, it offers the opportunity of a torsional resonance free operation by using a reliable standard motor design. Whereas for applications with operating speeds above 3500 rpm a 2-pole motor ($N_{pp}=1$) should be used. A motor with a number of pole pairs of 3 offers the design opportunity to realize driver speeds between 1200 rpm and about 2800 rpm. Lastly, it should be pointed out that this particular example is related to a grid frequency of 50 Hz.

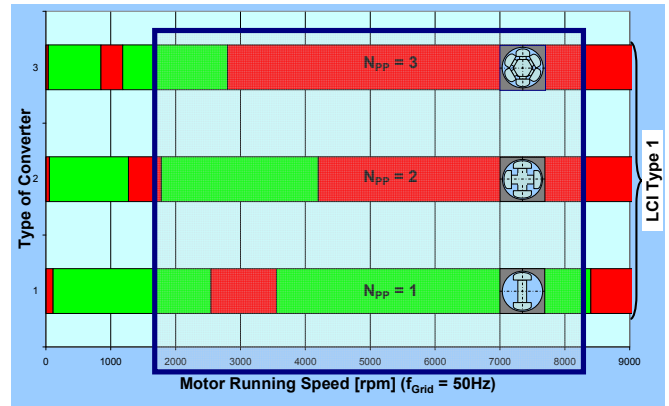

Figure 14. Typical Speed Range of Direct Driven Trains.

Consideration of Compressor Trains incl. Intermediate Gear

Figure 15 shows a typical motor driven compressor train including an intermediate gear used as speed increaser. That means that for this kind of application the speed range of the driver is normally lower in contrast to direct driven trains.

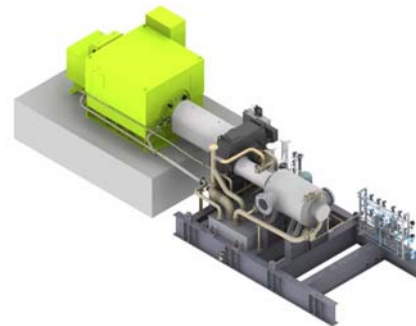

Figure 15. Typical Motor Driven Compressor Train incl. Intermediate Gear.

A typical application range of motor driven compressor trains with an intermediate gear is between 600 rpm and up to 3600 rpm, which can also be seen in Figure 16 for 50 Hz grid application. Whereas for direct driven trains the motor and compressor speed has to be identical, for trains including an intermediate gear the motor speed can be chosen almost independently from compressors optimal design speed. The main advantage for this train configuration is to tune the gear ratio in order to adapt the driver and the compressor speed. Accordingly, it is possible to use a motor speed range at lower or higher speeds in order to find a torsional resonance free train design solution for the particular application. However, for compression trains including an intermediate gear, the minimum operating speed and the fundamental TNF could run into a design conflict with fulfilling a separation margin of 10 percent related to running speed excitations as specified in API617. This essential design criterion has to be considered by selecting an adequate minimum operating speed which allows fulfilling the requirement. Otherwise, it can be helpful to tune the torsional stiffness of the low speed coupling in order to fulfill demand of separation margin.

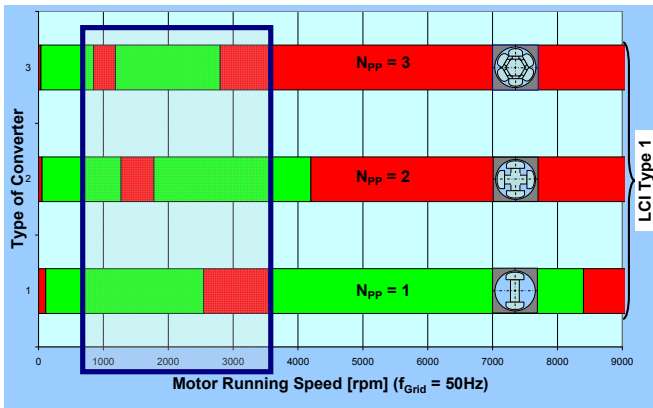

Figure 16. Typical Speed Range of Motor Driven Compressor Trains incl. Intermediate Gears.

As shown in Figure 16, speed ranges of about 600 rpm up to 2500 rpm can be realized by using a 2-pole motor design ($N_{pp}=1$), whereas a 4-pole motor design ($N_{pp}=2$) achieves a resonance free operation for a driver speed range between 1800 rpm and 3600 rpm or even higher. A motor design considering a N_{pp} of 3 can be used for applications with a driver speed range from about 1200 rpm up to 2800 rpm. Eventually, the optimal solution has to be determined case by case.

Transferring the New Train Design Concept to Relevant Inverter and Motor Types

The described designing strategy in order to avoid torsional resonances excited by inverter behavior can easily be adapted to all the other in-depth understood inverter applications. Figure 5 shows the behavior of the 12-pulse voltage source inverter. Several excitations are able to produce a torsional resonance condition but only few of them are able to produce higher torsional peak-to-peak amplitudes of more than 10 percent of the motor rated torque. Based on the dynamic torque measurements of a real train with a 12-pulse voltage source inverter under realistic load and electrical grid conditions, the mechanically relevant torsional excitation frequencies of the voltage source inverter can be identified. The torsional resonances with a torque amplitude above 10 percent of the rated motor torque are defined as mechanically relevant and should be therefore considered in the new train design concept. On the basis of the simulation results, the measured main resonances can be correlated with interharmonic excitation frequencies. It has to be pointed out that the inverter behavior is always product- and manufacturer-specific. Therefore, the relevant excitations have to be identified individually.

Separated into different types of inverters and their corresponding behavior, considering different number of pole pairs in combination with a realistic estimate of relevant TNFs, an inverter-motor-selection bar diagram can be prepared as can be seen in Figure 17. It is essential to prepare such a bar diagram separately for 50 and 60 Hz electrical grid frequencies.

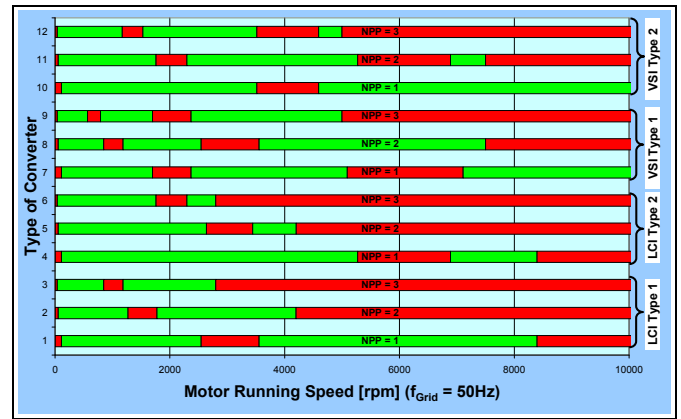

Figure 17. Bar Diagram of Motor Running Speed for VSIDS Motor-Inverter-Selection-Tool.

For proposals and also for the order execution phase, avoiding torsional resonances has to be considered in an early stage of the process. In order to achieve this target, a Motor-Inverter-Selection-Tool has been prepared and has already been integrated in the engineering process (Gallelli and Hütten, 2009).

Impact of Design Strategy

The design strategy of a specific project has to cover the technical and commercial impact of the VFD and motor selection. It is beneficial to optimize the overall compressor string instead of optimizing single components. Therefore, close cooperation between mechanical and electrical engineers is required to end up with the best fit for the individual train design. The above mentioned bar diagram for motor-inverter-selection leads to an operating speed range without the necessity of blending out frequencies, which is important for the overall process performance of the plant. In some cases, a slightly more expensive solution is required. In this case, a mutual agreement between process owner, EPC, and the compressor string supplier is required.

LATEST DYNAMIC TORQUE MEASUREMENT RESULTS OF VSIDS DRIVEN TRAINS

Verification1: Measurement results of a LCI driven Train

The train consists of a 25 MW 12-pulse LCI driven synchronous motor with double drive shaft with a speed increasing gear and a centrifugal compressor on both ends (Figure 18).

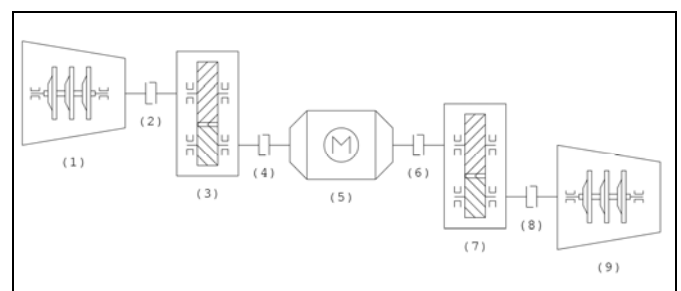

Figure 18. Layout of the LCI-Driven Train.

Strain gauges were applied at both low speed couplings between motor and the bull gears. Based on analytical investigation before measurement this train configuration has been identified to have two modes excitable at the motor main mass. Therefore a total number of 8 resonances with the 6- and 12-order interharmonics were expected. The measured dynamic torques are plotted as a trend in the upper half of figure 19 (dark blue and purple line). The thin lines above and below the measured torque indicate the technical relevance border of $\pm 10\%$ of the components rated torque. Taking the Campbell diagram in the lower half of same figure with excitation frequency versus motor speed as reference, the major vibratory torques are linked to the 6- and 12-order interharmonic excitation, whereas 18- and 24-order interharmonics cause no vibratory torque at all.

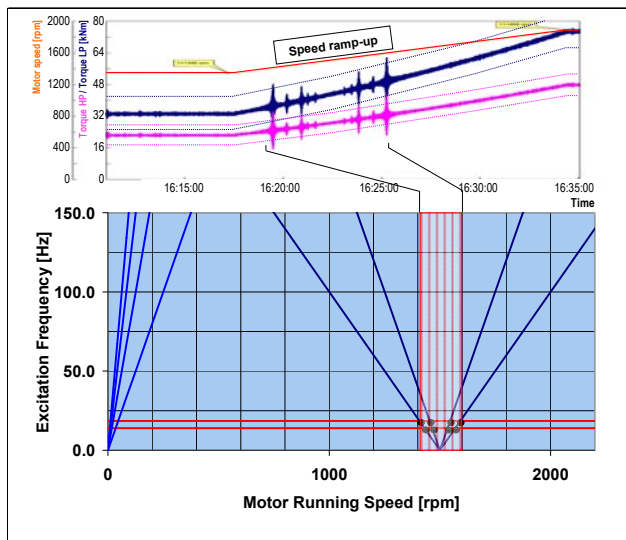

Figure 19. Ramp up of 25 MW LCI Driven Train.

The measurements prove that only the 6- and 12-order interharmonics of the LCI drive are technically relevant, as these show the highest torque response. An operation outside the marked speed range of 1410 to 1595 rpm would be completely free of resonances. The results also indicate that the VFD selection strategy can also be successfully implemented for more complex train configuration. Also in such a case it is essential to consider the excitable torsional modes and the relevant interharmonic excitations.

Verification 2: Measurement results of a VSI driven Train

In principle the same train configuration was designed consisting of a 10.5 MW 24-pulse voltage source inverter driven induction motor with double drive shaft with a speed increasing gear and a centrifugal compressor on both ends.

Also for this train both low speed couplings were equipped with strain gauges in order to observe the occurring dynamic torque response during string testing. Figure 20 shows the measured dynamic torque in the low speed couplings. Torque ripples are obviously visible during slow ramp-up within operating speed range. Nevertheless the maximum torque amplitudes are less than $\pm 10\%$ of the rated torque and are therefore due to their insignificant magnitude without any concerns for the mechanical integrity of the train components.

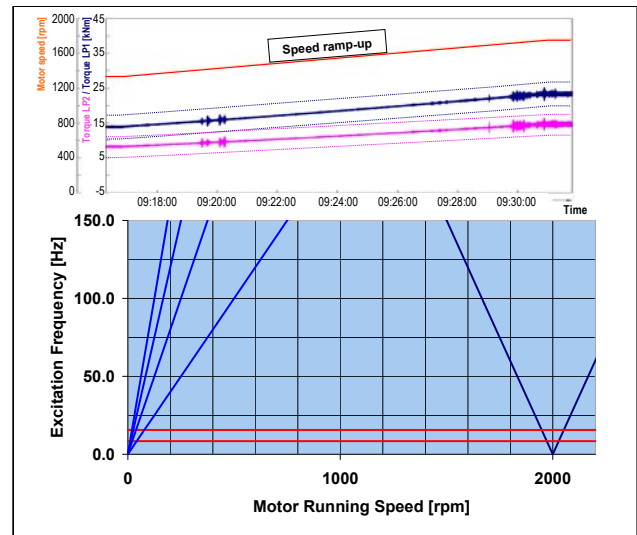

Figure 20. Ramp up of 10.5 MW VSI Driven Train.

Verification 3: Measurement results of a large LCI driven Motor Generator Train

Recent test bed activities included testing of a 78.7 MW 12-pulse LCI driven 4-pole synchronous motor with a rated speed of 3000 rpm. The motor was performance-tested while it was driving an identical motor in generator mode in a back-to-back arrangement (Figure 21).



Figure 21. 78.7 MW Motor Generator Back-to-Back arrangement

The two drives were coupled with the disc-pack type job coupling and a torque flange for static and dynamic torque measurements. Figure 22 shows the measured dynamic torque in the torque flange for a run-up from 700 – 3000 rpm with constant acceleration rate. The run-up time had to be kept short for cooling reasons, such that the acceleration rate was about 80 rpm/sec. This unfortunately deviates from the optimum verification condition with regard to resonance amplitudes, which would be a steady-state vibration. A quasi-stationary condition was in the past often approximated by the authors in other torque measurements by a very low acceleration of about 0.5 rpm/sec. In previous measurements, it was observed that a high acceleration and thus very short time span being in a resonant state generates lower vibratory torques than a low

acceleration rate. The resonances with the 6- and 12-order interharmonics were expected at 1417, 1458, 1541 and 1583 rpm using the measured fundamental TNF of 16.55 Hz. Although due to the quick run-up not easy to determine, three resonances at 1433, 1567 and 1600 rpm may be named, matching the predicted range accurately. The maximum torque amplitudes are lower than $\pm 10\%$ of the rated torque and are not yet critical for the mechanical integrity of the train components, but due to the acceleration considerations made above, higher vibration levels would be expected in a steady-state operating mode.

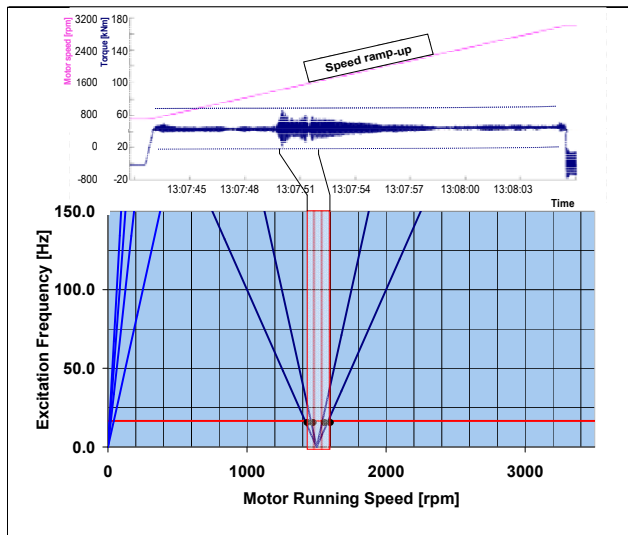

Figure 22. Ramp up of 78.7 MW LCI Motor Generator Train.

Based on this verification it has been demonstrated that a torsional resonance free operation in the operating speed range can be expected.

Measurement results of a large LCI driven Compressor Train

The same 78.7 MW drive as used in the back-to-back test was also tested with its associated compressor in a full-load string test. The 7-stage single-shaft compressor was directly coupled to the motor shaft with the disc-pack type job coupling (Figure 23).

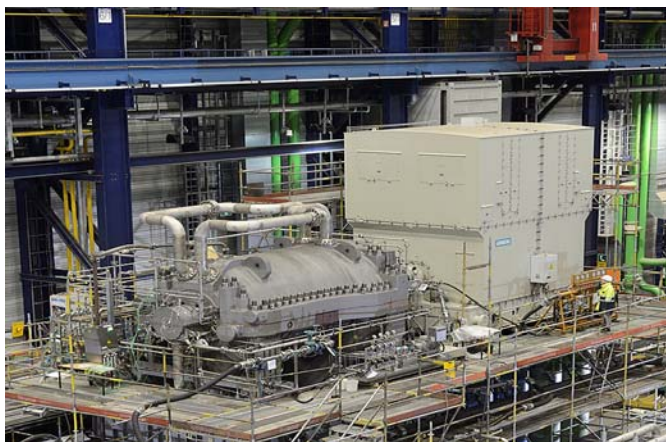

Figure 23. 78.7 MW large electric driven compressor string

The coupling was equipped with temporary torque measurement equipment with strain gauges and continuously measured the dynamic torque in the coupling spacer. Figure 24 shows the measured dynamic torque in the coupling for a start-up from 175 to 3000 rpm. Torque ripples are observed in the very low speed range, associated with the harmonics of the supply frequency f_{do} . The resonances with the 6- and 12-order interharmonics were expected at 1394, 1447, 1553 and 1606 rpm using the measured fundamental TNF of 21.12 Hz. Again due to the quick run-up not easy to determine, two resonances at 1409 and 1621 rpm can be mentioned, matching the predicted range accurately. The maximum torque amplitudes in a state of a resonance are observed also on a low level, due to the acceleration considerations made above. In a steady-state operating mode significant higher torsional amplitudes in resonance condition can be expected.

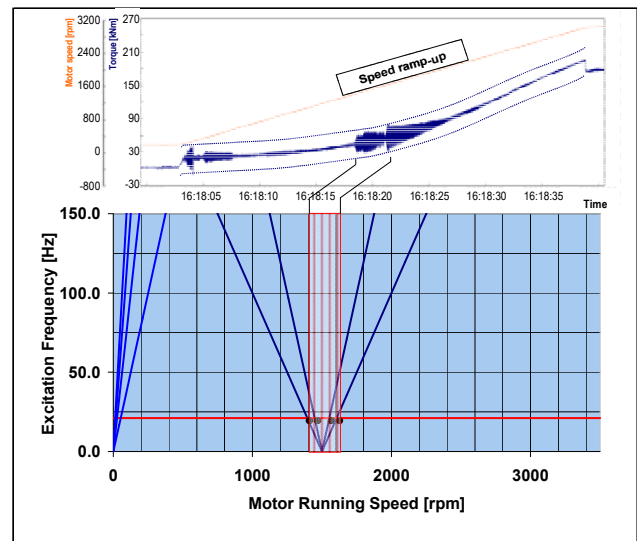

Figure 24. Ramp up of 78.7 MW LCI Driven Compressor Train.

The string test verified the results derived from the back-to-back test, i.e. the actual resonances with the interharmonic excitation were found at the expected motor speeds and no unexpected resonances were found.

Bringing together the measurement results of all 4 different train configurations and the corresponding expected Campbell Diagram for this train and inverter behaviour, it could be demonstrated that also no mechanically relevant torsional oscillation has been expected within the measured speed ranges. The latest measurements support the validity of the resonance free design concept based on general characteristics of the different VFD types with regard to interharmonics.

SUMMARY

- Torsional vibration may cause fatigue problems of torque transmitting elements of the train. In addition, it may also lead to higher radial shaft vibrations and/or gear clattering of pinion and bull gear shaft in intermediate gears.

- Nevertheless, also low radial shaft vibrations of a few microns were observed even in combination with measured dynamic torques of up to 80 percent of the motor rated torque.
- State of the art numerical investigations are generally able to identify the relevant interharmonic excitations. The TNF and the corresponding motor speed can be determined with adequate accuracy.
- Based on correlating simulated and experimental results further uncertainties in the entire electro-mechanical model exist. Due to these, the occurring torsional amplitude in resonance condition cannot be predicted with sufficient accuracy. Appropriate service factors are necessary to compensate for this, ensuring safe and reliable design.
- The pros and cons of the various well known strategies of dealing with interharmonic excitations have been presented within this publication.
- This paper presents a new train design concept in order to avoid the mechanically relevant torsional resonances excited by the inverter within the selected operating speed range.
- The new train design strategy is a result of correlating analytical and experimental results of the torsional train behaviour. The strategy considers mechanically relevant interharmonic of the inverter, selecting the motors number of pole pairs and the driver operating speed range.
- The success of design concept has already been verified by various examples as presented within this paper.

CONCLUSIONS

- The inverter behaviour is product and manufacturer-specific. Therefore, the relevant excitations have to be identified individually.
- Under consideration of the relevant individual behaviour of the inverters in combination with possible designs of the motors, number of pole pairs main torsional resonances can be avoided in operating speed range.
- One additional important aspect is that the engineering process of the motor allows realizing motor designs with individually required speed ranges.
- For direct driven trains, the driver speed has to be identical to the compressor speed. Nevertheless, for typical turbo compressor applications between 2000 rpm and 8000 rpm resonance free operating conditions can be realized.
- For trains including an intermediate gear the driver and the compressor speed can be selected independently from each other. In order to find a torsional resonance free solution, the driver speed can be adapted to compressor speed by the gear ratio.
- The presented pragmatic new train design concept offers reliable mechanical solutions in order to avoid interharmonic excitation within the motor speed range.

However, the commercial aspect has to be evaluated individually.

- This concept does not need any individual adjustments during testing and/or commissioning and does not lead to operational restrictions of the compressor train.
- Ultimately, for designing VSIDS driven turbo compressor trains, a close collaboration between the manufacturer of the driver and compressor is of vital importance.

NOMENCLATURE

AF	=	Amplification factor	
AC	=	Alternating current	
$C_{1,2,3}$	=	Constants associated with a particular VFD design	
DC	=	Direct current	
EPC	=	Engineering and procurement contractor	
f_{do}	=	VFD output frequency	(Hz)
f_i	=	Electrical line frequency	(Hz)
f_{exc-h}	=	Frequency of harmonic torque excitation	(Hz)
f_{exc-i}	=	Frequency of interharmonic torque excitation	(Hz)
f_{Ti}	=	Relevant torsional natural frequency	(Hz)
GHG	=	Green house gas	
i	=	Gear ratio	(-)
J_M	=	Mass moment of inertia of the motor	
J_C	=	Mass moment of inertia of the compressor	
LCI	=	Load commutated inverter	
LNG	=	Liquefied natural gas	
n_{min}	=	Minimum operating speed	(rpm)
n_{mc}	=	Maximum continuous speed	(rpm)
n_{op}	=	Motor operating speed	(rpm)
n_{syn}	=	Synchronous speed	(rpm)
N_{pp}	=	Number of pole pairs	(-)
THD	=	Total harmonic distortion	
TNF	=	Torsional natural frequency	
TNFs	=	Torsional natural frequencies	
VFD	=	Variable frequency drive	
VSIDS	=	Variable speed drive system	
VSI	=	Voltage source inverter	

REFERENCES

- Childs, D., Elrod, D., and Hale, K., 1988, "Rotordynamic Coefficient and Leakage Test Results for Interlock and Tooth-on-Stator Labyrinth Seals," ASME Paper Number 88-GT-87, Gas Turbine Conference.
- API Standard 617, 2002, "Axial and Centrifugal Compressors and Expander-compressors for Petroleum, Chemical and Gas Industry," Seventh Edition, American Petroleum Institute, Washington, D.C.
- Corcoran, J. P., Kocur, J. A., Mitsingas, M. C., 2010, "Preventing undetected train torsional oscillations", Proceedings of the Thirty-Ninth Turbomachinery Symposium, Turbomachinery Laboratory, Texas A&M University, College Station, Texas
- Corcoran, J. P., Kocur, J. A., 2008, "Torsional Oscillation Trouble on VFD Motor Driven Recip Compressor," Case Study at Proceedings of the Thirty-Seventh Turbomachinery Symposium, Turbomachinery Laboratory,

Texas A&M University, College Station, Texas.

de la Roche, L., Howes, B., 2005 "Lateral and torsional vibration problems in systems equipped with variable frequency drives", Beta Machinery Analysis Ltd., Calgary, AB, Canada.

Feese, T., Maxfield, R., 2008 "Torsional vibration problem with motor/id fan system due to pwm variable frequency drive", Proceedings of the Thirty-Seventh Turbomachinery Symposium, Turbomachinery Laboratory, Texas A&M University, College Station, Texas.

Gallelli, V., Hütten, V., 2009, "VFD-Motor-Selection" Siemens Energy Sector, Oil&Gas Division, Duisburg, Germany.

Hudson, J. H., 1992 "Lateral Vibration created by Torsional coupling of a Centrifugal Compressor system driven by a Current Source Drive for a variable speed Induction Motor," Proceeding of the Twenty-First Turbomachinery Symposium, Turbomachinery Laboratory, Texas A&M University, College Station, Texas, pp. 113-123.

Hütten, V., Zurowski, R., Hilscher, M., 2008, "Torsional Interharmonic Interaction Study of 75MW Direct-Driven VSDS Motor Compressor Trains for LNG duty," Proceeding of the Thirty-Seventh Turbomachinery Symposium, Turbomachinery Laboratory, Texas A&M University, College Station, Texas.

Kita, M., Hataya, T., Tokimasa, Y., 2008 "Study of a Rotordynamic Analysis Method that considers Torsional and Lateral coupled Vibrations in Compressor Trains with a Gearbox", Proceeding of the Twenty-seven Turbomachinery Symposium, Turbomachinery Laboratory, Texas A&M University, College Station, Texas.

Kocur, J. A., Corcoran, J. P., 2008 "VFD Induced Coupling Failure", Case Study at Proceeding of the Thirty-Seventh Turbomachinery Symposium, Turbomachinery Laboratory, Texas A&M University, College Station, Texas.

Kocur, J. A., Muench, M. G., 2011 "Impact of electrical noise on the torsional response of VFD compressor trains", Proceeding of the First Middle East Turbomachinery Symposium, Turbomachinery Laboratory, Texas A&M University, College Station, Texas.

Loscha, Th., Matern, Th., Beer, Chr., Hütten, V., Geilich, N., 2013 "Full Load Testing of Large Electrical Driven Train", Proceeding of the 17 th International Conference & Exhibition on Liquefied Natural Gas (LNG 17), Houston, Texas.

Naldi, L., Biondi, R., Rossi, V., 2008 "Torsional vibration, in rotordynamic system, identified by monitoring gearbox behaviour", Proceedings of ASME Turbo Expo 2008, Berlin, Germany.

Naldi, L., Rotondo, P., Kocur, J., 2008, "Development and Implementation of VFD Active Damping to Smooth

Torsional Vibrations on a Geared Train", Case Study at Proceeding of the Thirty-Seventh Turbomachinery Symposium, Turbomachinery Laboratory, Texas A&M University, College Station, Texas.

BIBLIOGRAPHY

API Standard 684, 2005, "API Standard Paragraphs Rotordynamic Tutorial: Lateral Critical Speeds, Unbalance Response, Stability, Train Torsionals, and Rotor Balancing," Second Edition, American Petroleum Institute, Washington, D.C.

Hütten, V., Beer, Chr., Krause, T., Demmig, S., 2011 "VSDS Motor Inverter Design Concept for Compressor Trains avoiding Interharmonics in Operating Speed Range", Proceeding of the First Middle East Turbomachinery Symposium, Turbomachinery Laboratory, Texas A&M University, College Station, Texas.

Rotondo, P., Andreo, D., Falomi, St., Pieder, J. , Lenzi, A., Hattenbach, T., Fioravanti, D., De Francis, S., 2009, "Combined Torsional and Electromechanical Analysis of a LNG Compression Train with Variable Speed Drive System," Proceeding of the Thirty-Seventh Turbomachinery Symposium, Turbomachinery Laboratory, Texas A&M University, College Station, Texas.

Song-Manguelle, J., Schröder, St., Geyer, T., Ekemb, G., Nyobe-Yome, J.-M., 2009 "Prediction of Mechanical Shaft Failures due to Pulsating Torques of Variable Frequency Drives", IEEE IAS 44th annual meeting.

ACKNOWLEDGEMENTS

The authors would like to thank the management of Siemens AG for authorizing the publication of this design concept.