



DEVELOPMENT AND DESIGN OF ANTISURGE AND PERFORMANCE CONTROL SYSTEMS FOR CENTRIFUGAL COMPRESSORS

Saul Mirsky, PE

Chief Technology Officer
Compressor Controls Corporation
Des Moines, IA, USA

Wayne Jacobson

Global Technology Manager
Compressor Controls Corporation
Des Moines, IA, USA

David Tiscornia

Control Systems Engineer
Compressor Controls Corporation
Houston, TX, USA

Jeff McWhirter, PE

Houston/Gulf Coast Sales Manager
Compressor Controls Corporation
Houston, TX, USA

Medhat Zaghloul

Regional Manager – Abu Dhabi
Compressor Controls Corporation
Al Reem Island, Abu Dhabi, UAE



Saul Mirsky, CCC's Chief Technology Officer, is the distinguished author of numerous technical papers and esteemed lecturer on turbomachinery control solutions. Mr. Mirsky has been with CCC since 1980 and is part of the Company's Leadership Team. In this position, he serves as a technology consultant, coordinating efforts throughout the

Company to ensure consistency in both methodology and technology. In addition, he also analyzes and devises strategies for turbomachinery control solutions. Mr. Mirsky continuously researches technological control issues in various industries and recommends product development improvements to new and existing products. His work has awarded him several patents in control methodology for turbomachinery. Mr. Mirsky is a professional engineer and holds a Master's Degree in electrical engineering from Polytechnical University in Riga, Latvia. Mr. Mirsky may be reached through the Company website: <http://www.cccglobal.com/contact-us>



Jeff McWhirter is the Houston/Gulf Coast Manager for CCC. His thirty plus years of experience in turbomachinery controls encompasses many industries and extends to LNG plants - implementing both the APCI and COP processes, refineries utilizing fluidized catalytic cracking(FCCU) and power recovery, NGL facilities, oil and gas

production facilities including separation, injection, gas lift and sales gas, as well ammonia and ethylene plants. Mr. McWhirter is a member of the working committee for the new Machinery Protection System API 670 5th edition specification and joint authored a patent entitled "Compressor-Driver Power Limiting in Consideration of Antisurge Control" in December 2012. Jeff received his B.Sc. degree in Mechanical Engineering from Texas A&M University and is a member of the ASME



Wayne Jacobson is CCC's Global Technology Manager in Des Moines, IA.. Wayne joined CCC in 1996 as a Systems Engineer with a BS in Mechanical Engineering from the University of Wisconsin – Platteville. His responsibilities include providing technical guidance and support throughout the organization, develop and enhance control

applications, maintain and improve standard engineering and overseeing the overall technical development of engineering staff.



Medhat Zaghloul is CCC's Regional Technology Manager for the Europe, Middle East and Africa regions with CCC, based in the Abu Dhabi Office. Medhat joined CCC in 1993 with over 35 years in the oil and gas industry and 15-years specific to instrumentation controls for the petrochemical industry. He is responsible for the development of technical solutions and control applications, and providing

technical guidance and support. Mr. Zaghloul holds a B.Sc. in Electrical Engineering from the Cairo Institute of Technology in Egypt.



David Tiscornia is a control systems engineer with CCC. Throughout his 12 year tenure at CCC, David has held various positions including software development, project engineering, and new technology development. An accomplished lecturer and thought leader, Mr. Tiscornia has written and presented papers and articles on

turbomachinery control solutions at industry events around the globe. David holds BS and MS degrees from Purdue University and is a registered Professional Engineer in Iowa. He currently offices in the Houston, TX location and can be reached via the CCC website (www.cccglobal.com/contactus)

ABSTRACT

The development and design of control systems for centrifugal and axial compressors is discussed and explanations given to bring together features of control systems on varying machine designs. Potential problems resulting from such differences will be addressed and resolutions offered.

INTRODUCTION

Control systems for centrifugal and axial compressors (below term Dynamic Compressors, or for simplicity: Compressors) follow the same rules and reasoning as do control systems for other plants, processes, machines, etc. At the same time, the nature of Dynamic Compressors includes many additional dissimilar properties that make it essential to pay considerably more attention to the design of control systems for these machines. It is tempting to design and implement these control systems “by the book”, and many systems were and still are being implemented that way. However, operation of many control systems that are below average acceptability tell us that at best these systems are wasting energy, and often, they may be allowing damage to the machines that they are intended to control and protect.

This Tutorial is intended to help the Mechanical, or Process Engineer that understands issues associated with the design of mechanical elements of the machine and, is familiar with the processing of gas through the system, but does not have sufficient experience with the design of control systems for these machines. It is assumed further in the Tutorial that the user of the Tutorial is familiar with multitude topics involving Dynamic Compressors and their application in industrial processes. The focus of the Tutorial is to explain the direction that must be taken in the design of the control systems for Dynamic Compressors as based upon many years of experience from the author's company. This Tutorial stresses our explanation of how to bring together features of the control system regardless of varying machine designs, and at the same time, how to keep track of distinctive potential problems that result from differences between machines and processes that make the design of these systems more demanding and uncertain.

The proper control system for a complex object can be designed only after achieving a solid understanding of the object to be controlled, the Dynamic Compressor in this case. What follows is a brief review of the important features of a Dynamic Compressor as a controlled object.

DYNAMIC COMPRESSOR AS A CONTROLLED OBJECT

The Dynamic Compressor is a machine that converts mechanical energy of the driver (electric motor, steam or gas turbine, etc.) into energy of the gas being processed. Operation of the Dynamic Compressor can be well presented in the Compressor Map (or, Compressor Performance Map). The Compressor Map (Figure 1) shows operation of the compressor in an X-Y plot in which the Volumetric Flow, Q_s is used as X-axis, and the Compression Ratio, R_c as Y-axis of the plot (further below this map is referred to as the map in Q_s-R_c coordinates, the other, most useful for analysis compressor map is plotted in Q_s-H_p coordinates).

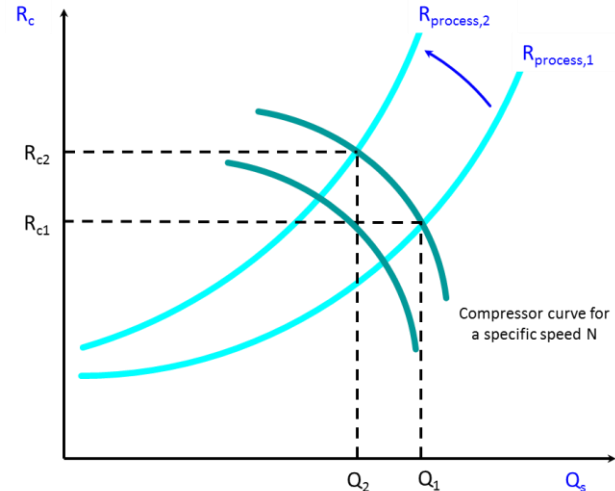

Figure 1. $Q_s - R_c$ Compressor Map with common lines of resistance, speed, and change in each.

Many various coordinates can and are being used, and at times must be also integrated into the analysis of the compressor, but the Q_s-H_p plot allows a number of advantages. The Q_s-H_p plot is used in a majority of cases as the de-facto standard way of presenting machine performance, whereas the Q_s-R_c map is used when combined operation of the compressor and the process is being reviewed. The performance of the compressor is shown in the compressor map for a set of constant speeds, making the Speed, N of the compressor the 3rd commonly seen coordinate of the map, while the controlled process can be represented in the Compressor Map as lines of resistance. Figure 1 shows a few lines of constant resistance that are typical for compressor operation. In its steady state, the operating point of the compressor is always located at a point of intersection of the line of constant resistance and the line of constant speed. As the process resistance or the compressor speed changes, the operating point

follows with some delay and lag to the new point of intersection (see Figure 1).

The Compressor Map, Figure 2, allows one to recognize the first set of challenges to the control system: the operating zone of the compressor is a region constrained on almost all sides by additional boundaries that may need to be controlled, or at least must be taken into account in the design (Ludtke, 2004).

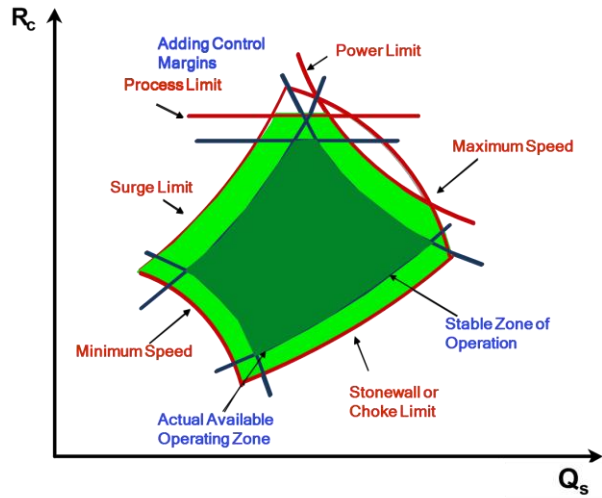

Figure 2. Q_s - R_c Compressor Map with Boundaries

Compressor Operating Boundaries

Surge Limit Line (SLL)

Operation of the compressor must take place to the right of the Surge Limit Line (SLL); crossing the SLL leads to surge. Many definitions of surge are used, but they all settle on stating that surge is an event in which the energy contained in the gas being compressed becomes equal, or larger than the energy imparted by the rotating impeller (or, set of blades) of the compressor. Essentially, energy accumulated in the compressed gas becomes greater than the energy level the rotating impeller of the compressor can sustain, and, as a result, the gas rapidly expands in an abnormal direction back through the compressor. Stall is another well-known phenomenon; at times it precedes the surge event and it may lead to the onset of surge. Surge is a very rapidly occurring event of gas expansion through the compressor, in most cases a loud sound can be heard by the observer. Once the gas energy in the volume associated with the discharge of the compressor is dissipated by flowing back to the suction of the compressor, the operation of the compressor is returning back to normal, but if preventive measures are not taken, the compressor eventually proceeds back into the next surge. As a result, surge that is not aborted, becomes a cyclical event, with frequency dependent on the design of the compressor and, on piping and volumes of the process system (typically observed, surge cycle times are 1-5 sec. for centrifugal compressors, and 3-20 sec, for axial compressors). Figure 3a illustrates trajectory of the operating point of the typical compressor during surge cycle in the

Compressor Map, while changes in discharge pressure, flow and discharge temperature for a typical compressor running in a surge cycle are shown in Figure 3b.

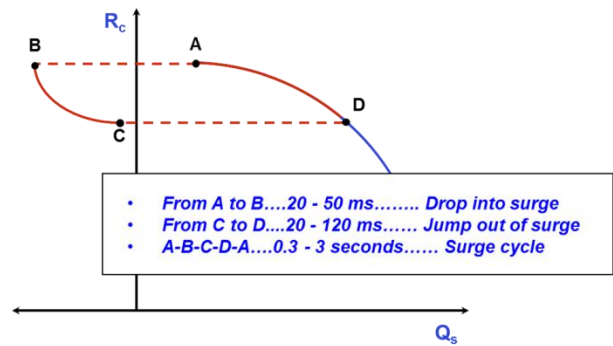
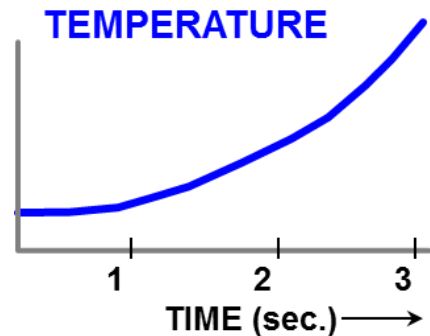
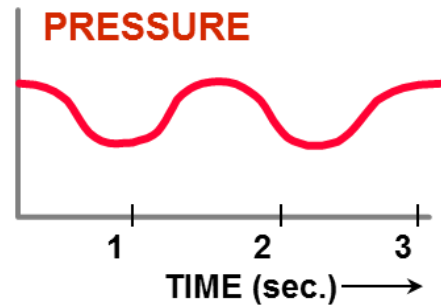
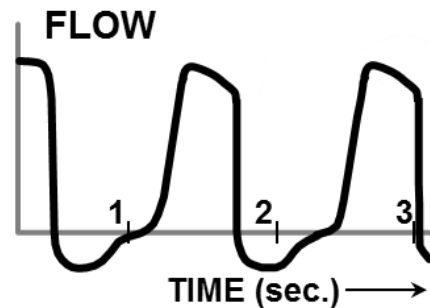

Figure 3a. Surge cycle in the Q_s - R_c Compressor Map.



Figures 3b. Traces of flow, discharge pressure and temperature of compressor surge cycling.

Consequences of surge are: complete defeat and reversal of the balancing design of the rotating bundle of the

compressor leading to abnormally high loads on bearings (especially thrust bearings) and seals; exceptionally high levels of vibration; rapid rise in the internal temperature of gas, and consequently, a rise in the internal temperature of the compressor; inability to meet flow and pressure demands of the process. For the majority of modern compressors surge is a highly damaging, sometimes a destructive event. The degree of damage to compressors during surge varies depending on design and application, and statistics are incomplete for obvious reasons. However it is a common industry belief that a ½ hour of accumulated surge is detrimental enough for the compressor to become damaged beyond acceptable level. Operation of the compressor to the left of the SLL must be avoided and a surge event that evolved into surge cycling must be stopped immediately.

Choke, or Stonewall Line.

The lower part of the compressor map is limited by the choke, or stonewall line. Below this line the velocity of gas in some cross section inside of the compressor reaches local sonic velocity. Further increase of throughput of the compressor beyond this line would require substantially more energy, the performance lines become more vertical (in many cases they do become vertical), and the event is often accompanied by heightened vibration along the blades of the compressor. Some centrifugal compressors are able to tolerate operation in choke for prolonged periods of time, but for many compressors, especially operating at higher gas density, prolonged operation (more than few minutes) beyond this line is not recommended by the manufacturer, and for axial compressors especially, choke event may be destructive much sooner.

Line of Maximum Power

In most cases, a “line of maximum power” represents the maximum power available from the driver to the compressor. In some instances, it may represent the maximum power that is allowed to be dissipated in a weak element of energy transmission chain - possibly one of the shafts, coupling, etc. In many of these cases, it is the energy consumption by the compressor being the power consumer of the chain that must be limited to avoid damage to elements of the compression train.

Lines of Maximum and Minimum Pressure (Process or Machine Design constraint)

Lines of maximum and minimum pressure represent the maximum or minimum allowable pressure levels dictated by the design of the machine, of process piping, vessels, and/or equipment.

Lines of Maximum and Minimum Speed

Continuous operation of the machine beyond maximum and minimum speed is not allowed due to reaching mechanical strength limits when above maximum speed and the

possible, unacceptably high levels of vibration beyond both maximum and minimum speeds.

In addition to the lines representing the boundaries of the operating envelope above, it is also possible to show in the compressor map the line representing the typical objective of the operation of the compressor - for example, the line of constant discharge pressure, or constant flow.

From Compressor Map to Invariant (nearly) Process Variable for Antisurge Control

The compressor map described above allows visualizing and evaluating acceptable envelope of normal operation. The compressor map also allows bridging the available data describing mechanical and aerodynamic performance of the compressor to the data necessary for the development of the antisurge control system.

A typical compressor map is usually presented in Q_s – H_p coordinates of volumetric flow in suction, Q_s and Polytropic Head, H_p . These coordinates are used commonly by the compressor manufacturers since they allow for a summary view of the thermodynamics of energy conversion in the compressor. Furthermore, they are associated reasonably well with the currently used methods of design of the internals of the compressor. The first inclination for the design of an antisurge control system may be to use the Q_s – H_p compressor map as it comes along with the compressor, but there are at least two additional obstacles that are necessary to be aware of:

Q_s – H_p compressor map coordinates

The coordinates of the Q_s – H_p compressor map are not easy, if possible at all, to use as input signals into the antisurge control system.

Shown below are simplified equations for the Volumetric Flow, Q and Polytropic Head, H_p

$$Q_s = A * \sqrt{\frac{dP_0 * T_s * Z_s}{P_s * MW}} \quad (1)$$

$$H_p = \frac{Z * R * T_s}{MW} * \left(\frac{Rc^\sigma - 1}{\sigma} \right) \quad (2)$$

where

$$Z = (Z_s + Z_d) / 2 \quad (3)$$

$$Rc = Pd / P_s \quad (4)$$

$$\sigma = (k - 1) / (k * \eta) \quad (5)$$

$$k = C_p / C_v \quad (6)$$

The first, immediately obvious problem with direct use of Q_s - H_p coordinates of the compressor map in the control system is that these variables are completely impractical for application in a system that requires high speed, efficiency, accuracy, and reliability of input signals. Only the variables of pressures and temperatures in the equations above can be measured directly by use of available, reliable, and tested in applications, industrial grade transmitters. Parameters of gas, like Z , MW and k , can be measured by modern available equipment. However accuracy, speed of response, reliability, etc. of these measurements makes them unacceptable for inclusion into a closed loop control system. The efficiency η of the compressor (or compressor stage) of interest proves even more elusive because its measurement would involve comparing actual compression cycle with the idealized compression cycle for the same gas.

Inferential Control System

In control systems the compressor antisurge control system belongs under the classification of an “inferential control system”, meaning that direct measurement of the controlled variable - distance to surge in this case - is unavailable, and that the controlled variable has to be inferred from available measurements. There are two reasons for this. First, the position of the SLL as presented in the compressor map represents at best, the latest known position of the SLL that may change in an unpredictable way with time and with change in condition of the compressor. Second, position of both the SLL and the operating point is influenced by changes in gas composition, but as stated above, the use of gas composition measurements for inclusion into the antisurge control system should be avoided. There is not much that can be done to improve measurability of the drift of the SLL as a result of a changing condition of the compressor, unless some newly invented method that allows a direct measurement of the SLL is employed. It is possible, however, to deal with the second problem.

For the operation of the antisurge control system, it is necessary to measure and further express the distance between present position of the operating point and the SLL of the compressor. Varying position of the operating point can be measured, but only in units of flow, pressure and temperature without accounting for change in gas composition (see explanation above); location of the SLL of the compressor is not measurable directly during normal operation at all. Since position of the SLL is not-measurable directly, it must be inferred from the best data, previously obtained, and from available flow, pressure and temperature measurements.

In practice this means that the SLL available for control is representing our best knowledge at the time, and that position of SLL must be periodically corrected to reflect the change in its position with time and with compressor condition, and that position of SLL also must be constantly reflecting changes in gas parameters. Little can be done to improve the ability of direct measurement of SLL position, therefore continuous correction of the condition of the compressor drift is

hardly possible - but it is possible to work around continuous correction for gas parameter changes.

One possible, but impractical, method for this would be to obtain gas parameters necessary for the equations 1-6 above (in essence this would follow calculations that are recommended and described in the ASME Testing Code PTC 10-1997). But since the use of measurements of gas parameters is impractical, this method is not used for operation of the antisurge control system.

Another alternative is to simplify the calculated control inputs to the point where the calculations would not contain variables that are difficult to obtain, but additionally and most importantly, to perform this simplification in a way that does not negatively affect accuracy of the result. Substantial amount of studies of the topic of expressing control inputs for a compressor in an invariant coordinate system can be found in literature (Batson, 1996, Bloch, 1996).

Described below is the practical method performed in a few steps of expressing compressor map in invariant coordinates and establishing an appropriate control variable for the antisurge control:

Expressing Compressor Map in Invariant Coordinates

Equations (1) and (2) representing the original compressor map are a very good starting point to move to the desired result. First the equation (1) is squared

$$Q_s^2 = A^2 * \frac{dPo * Ts * Zs}{Ps * MW} \quad (7),$$

Both equations (2) and (7) are then divided by a common factor $\frac{Ts * Zs}{MW}$, which results in two new variables: Reduced Flow Squared - q_{sr}^2 and Reduced Head - h_{pr}

$$q_{sr}^2 = \frac{Q_s^2}{Ts * Zs} = \frac{A^2 * \frac{dPo * Ts * Zs}{Ps * MW}}{\frac{Ts * Zs}{MW}} = \frac{dPo}{Ps} \quad (8),$$

and

$$h_{pr} = \frac{Hp}{Ts * Zs} = \frac{\frac{Z * R * Ts}{MW} * \left(\frac{Rc^\sigma - 1}{\sigma}\right)}{\frac{Ts * Zs}{MW}} = \left(\frac{Rc^\sigma - 1}{\sigma}\right) \quad (9)$$

Equations (8) and (9) omit constants, and an assumption is made for the equation (9) that Zd/Zs remains reasonably constant, which is approximately correct within operating range of many applications, and if this is not so further analysis must be performed.

The new variables, Reduced Flow Squared, q_{sr}^2 and Reduced Head, h_{pr} , do not contain non-measurable variables that change with gas composition changes. In addition, the compressor map in these coordinates acquires property of

invariance to changes in gas parameters. A number of papers were published on the topic of proper selection of invariant coordinates for the needs of the antisurge controls. The ones selected above are the best served, in the opinion of the author's Company. As may be seen on Figure 4, use of these variables for the compressor maps representing operation of the compressor with different gas compositions reduces the multitude of SLL into one contiguous, compacted SLL that can be implemented in the control system.

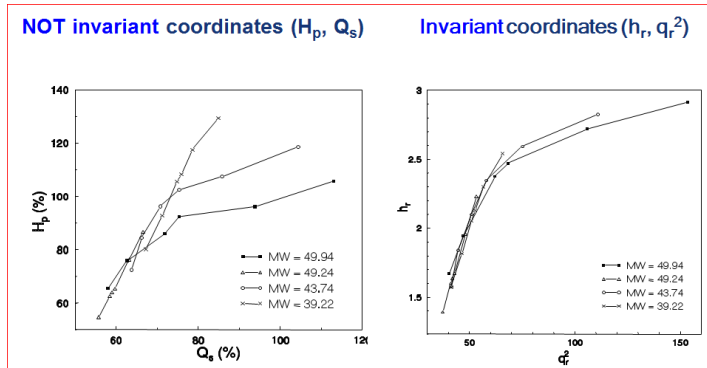

Figure 4. Reduction of the SLL in Q_5 - H_p coordinates

The derived above equations constitute a good basis for a nearly invariant compressor map coordinate, but even so, the designer of the antisurge control system must verify and validate assumptions made along the way. A recommended sequence is: once the implementation of the system is decided upon and the SLL is expressed as invariant and acceptable to the control system implementation, the designer needs to perform back-calculations to prove that the resulting error does not exceed acceptable level.

A word of warning is in order. Many other invariant parameter systems can be derived (Batson, 1996), but there does not seem to be any advantage of using a majority of them, and many of these parameter systems do not meet the requirement of a high speed response for the system, or do not exhibit an adequate sensitivity to change of position of the operating point. As will be shown later, the antisurge control system must be able to operate with an overall reaction speed that allows it to cope with the high speed of commencement of surge, which means that the selected variables must be able to change at a speed not lower than possible changes in actual position of the operating point. The analysis in this Tutorial is focused on flow being one of the most useful variables, with expectations for speed of pressure signals being somewhat slower, and only horsepower of the driver and rotating torque, that may be able to meet our high speed requirements.

Some notes for design of the antisurge control systems must be made in use of the resulting variables in equations (8), (9) above:

As previously stated, accuracy of the resulting calculations is limited caused largely in part, to a residual error

due to the fact that Zd/Zs may not remain constant throughout operating range of the compressor.

Additionally, derivation of invariant coordinates is based on what is termed as: accepting conditions of similarity between different operating conditions for which various idealizing assumptions are being made. In practice, when gas conditions are changed in a wide range, the reduced coordinates become less accurate due to a large number of unaccounted for factors (ASME PTC 10-1987). For example, the compressor maps represent well operation of the compressor if the measurements are taken immediately in the compressor, but actual instrumentation performing these measurements is installed outside of the compressor with inevitable errors due to losses which affect the final results.

Still, analysis of the implemented control systems shows that for majority of cases, the derived coordinates successfully reduce the multiple lines representing the complex surface of surge boundary into a singular line that can be expressed by using only simple, available measurements (see Figure 4).

Distance to Surge in Compressor Map in Invariant Coordinates

The analysis above resulted in a pair of reduced X-Y map coordinates allowing for all desired qualities. Here is our resulting pair:

$$q_{sr}^2 = \frac{dP_o}{P_s} \text{ and } h_{pr} = \left(\frac{Rc^\sigma - 1}{\sigma} \right) \quad (10)$$

The next step is to produce a singular control variable that can be used for the antisurge control. Division of the two coordinates of equation (10) allows calculating slope of the line to the operating point in the compressor map, $Slope_{OPL}$

$$Slope_{OPL} = h_{pr}/q_{sr}^2 \quad (11),$$

Likewise, division of the two coordinates of equation (10) for a point along the SLL allows one to calculate slope of the line to the surge point in the compressor map, $Slope_{SLL}$

$$Slope_{SLL} = h_{prS}/q_{srS}^2 \quad (12)$$

Finally, we can define the distance to surge control variable, as

$$S_S = Slope_{OPL}/Slope_{SLL} \quad (13)$$

The new variable S_S represents an angular measure of the distance between the operating point and the SLL in the compressor map with X-Y coordinates as defined by equations (10). Since coordinates of the compressor map as per equation (10) were invariant, the derived variable S_S retains the property of invariance, too.

The variable S_S is calculated continuously in the antisurge control system. Since S_S is lesser than 1 ($S_S < 1$) for normal operation, and S_S is greater than 1 ($S_S > 1$) when the system is in surge, this allows for a comfortable comparison of different compressor systems by using one and the same surge parameter that produces similar indications for different machines (see Figure 5).

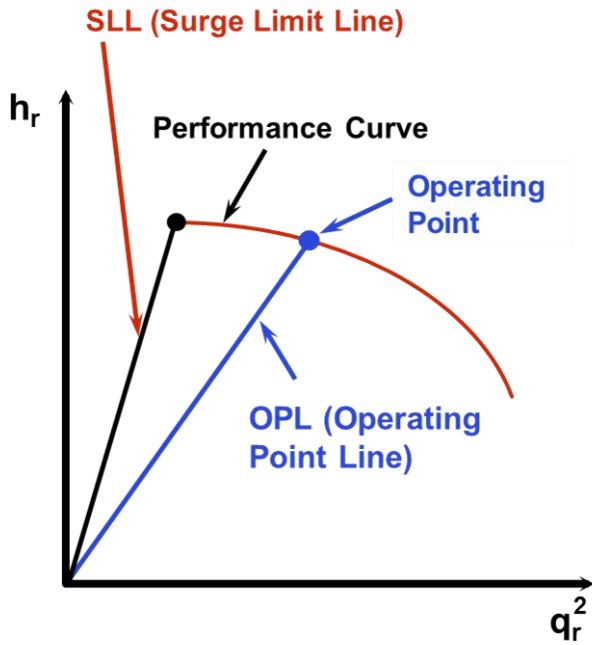

Figure 5. Measurement of distance to surge

The equation (13) is further converted into a form allowing calculations in the controller.

$$S_S = K * f(h_{pr}) / q_{sr}^2 \quad (14)$$

Introduction of a scaling coefficient K and function $f(h_{pr})$ in quantity $K * f(h_{pr})$ is intended to make S_S equal to 1 for all points along the SLL, which allows to implement the derived SLL curve in a form of a characterizer with sufficient number of points in invariant coordinates as per equation (14). Obviously, the number of points used for characterization should be higher for curved SLL and, two points would be sufficient if the original SLL is a nearly straight line.

Along with serving as a normalized indicator of distance to surge, variable S has an advantage of providing for a parametric increase in the gain of the antisurge control system as it approaches surge. It can be noticed in the equation (14) that with approach to the SLL variable q_{sr}^2 is continuously decreasing, and that for the same decrement in flow the distance to surge variable S produces larger and larger increments - in other words the gain of the control system increases as it approaches surge without use of any additional parameters, which is advantageous in the improvement of quality of the antisurge control (see Figure 6).

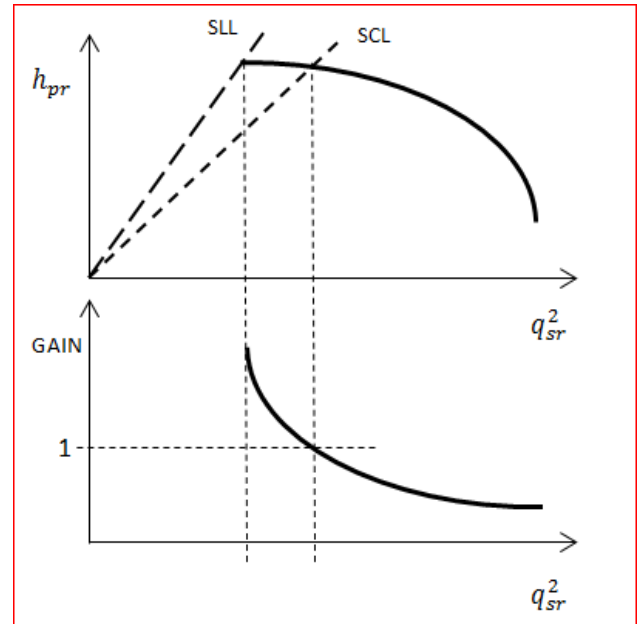

Figure 6. Parametric increase in the gain of the system with approach to surge

Polytropic exponent σ in the equations (10) above can be assumed constant if gas composition and gas parameters remain reasonably constant within operating range of the compressor, but it may be necessary to correct for gas composition changes in some cases.

Using the definition of polytropic process:

$$(Pd/Ps)^\sigma = (Td/Ts) \quad (15)$$

It is possible to calculate the polytropic exponent σ on line by using only available pressure and temperature signals, basically using the results of the compression process for calculation.

$$\sigma = \log(Td/Ts) / \log(Pd/Ps) \quad (16)$$

The calculated value of polytropic exponent σ can then be used in equation (10) for more accurate representation of gas composition changes. The application of equation (16) works out very well when used within families of similar gases, for example within mix of mostly linear hydrocarbons with small quantities of other gases, but may not be as useful if the mixture of gases is such that the ratio of specific heats k is not changing with the change in molecular weight and compressibility.

Selected Applications of compressor Map in Invariant Coordinates

In some application, equations (8) and (9) can be simplified without detrimental effect to the desired invariance of coordinates. For a controls engineer, it is always attractive to construct an elegant system (this includes reducing number of

inputs and complexity of calculations) without sacrificing the quality of antisurge control. The examples below demonstrate that there are cases that can be satisfied by simple solutions, but for some cases the complexity of the solution is justified.

“Fan Law” compliant compressor

A “Fan Law” compliant compressor in constant gas composition application may be adequately controlled by a simple antisurge control system. A well-known Fan Law for the compressors states that $Q \sim N$ and $H_p \sim N^2$, and it is well applicable to low head single stage compressors, hence the name “Fan Law”. In our derived $q_{sr}^2 - h_{pr}$ coordinates, since both coordinates are proportional to speed N , this means that the SLL for this type of a compressor is represented by a straight line out of origin of coordinates. Literature (Staroselsky, 1979, Gresh 2001) shows that the straight line assumption can be applied as long as the deviation from the Fan Law is limited, and as long as the gas composition remains constant.

If polytropic constant σ in equation (9) is considered constant and if the values of R_c are not particularly high, the equation (9) can be expressed, as

$$h_{pr} = \left(\frac{R_c \sigma - 1}{\sigma} \right) \cong R_c - 1 = \frac{P_d}{P_s} - 1 = \frac{P_d - P_s}{P_s} \quad (17),$$

and distance to surge S can be expressed as

$$S = K * f(h_{pr}) / q_{sr}^2 = K * \frac{(P_d - P_s) / P_s}{dP_o / P_s} = \frac{P_d - P_s}{dP_o} = \frac{dP_c}{dP_o} \quad (18)$$

An adequate antisurge control for this compressor may need only two differential pressure transmitters!

To reiterate, the above solution works well only if the gas composition is not changing, and if the head of the compressor is low enough to result in a straight SLL. The exact value of maximum R_c , for which this method is applicable, differs dependent on the type of gas used, the head of the compressor and the acceptable accuracy of implementation.

Compressor with Inlet Guide Vanes

Compressors with Inlet Guide Vanes may require IGV position signal. A majority of axial compressors and some of centrifugal ones are equipped by Inlet Guide Vanes (IGV) to control throughput of the compressor.

For the purposes of the antisurge control system, compressors with IGV can be viewed as machines with variable geometry, and change in the signal of IGV position indicates change in the machine geometry. In the compressor map shown in Figure 7a, the change in the machine geometry is noticeable as a substantial change in the slope of the SLL and in the shape of the performance curves for individual IGV position. For illustration purposes the same Figure 7a shows an approximate

shape of the SLL if the machine would not be equipped with IGV, but, as an example, would use variable speed resulting in constant slope of the SLL.

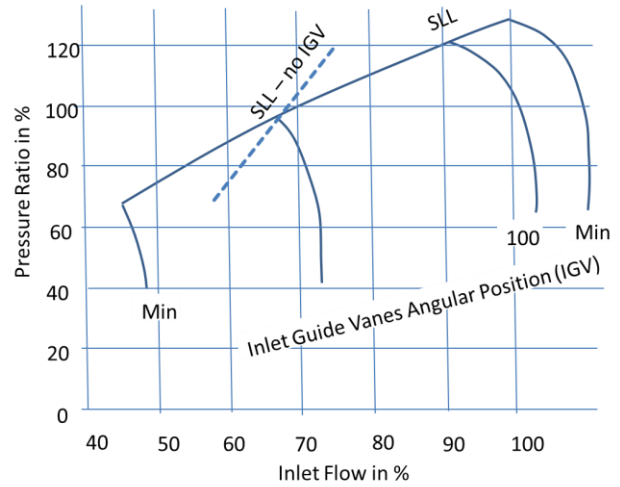

Figure 7a. Compressor map for an axial compressor with IGV

In some compressors, centrifugal machines especially, the effect of changes in IGV position on the SLL is not as expressed as in Figure 7a. But for axial compressors especially and for some centrifugal compressors, the effect is very strong and these machines must be always instrumented with inclusion of the IGV position into the control system. A large number of machines fall in between and the decision must be made by the designer of the control system whether to use the IGV position signal in the control scheme. That notwithstanding, it is always desirable to include the IGV position signal into the set of signals available for post-analysis of the system performance to be able to identify IGV position as a possible disturbance to operation of the antisurge control system.

Distance to surge for machines with IGV that require correction for variable slope SLL is calculated as

$$S = K * f_1(h_{pr}) * f_2(IGV) / q_{sr}^2 \quad (19)$$

Characterize $f_2(IGV)$ in the equation (19) is used to modify the slope of the SLL with change in IGV position, turning the SLL clockwise with opening of the IGV (see Figure 7b.)

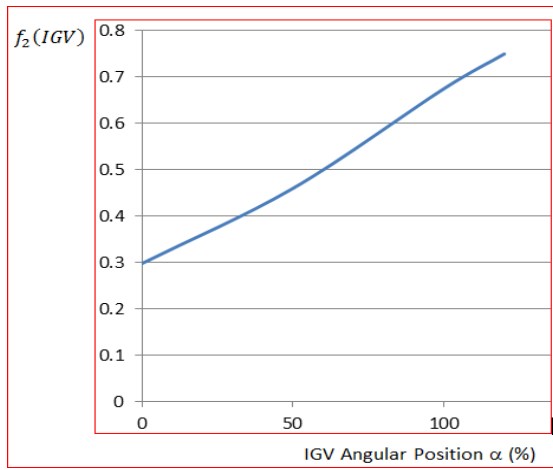

Figure 7b. Characterization of the SLL for axial compressor with IGV in Figure 7a

Variable Gas Composition

Variable gas composition is one of the more challenging applications for antisurge control systems. Implementation of the invariant coordinate system for the antisurge control system is reviewed extensively in the literature (Batson, 1996). Shown in Figure 8a and Figure 9a are the compressor maps for two applications with variable gas composition. It is obvious from the Q_s-H_p compressor maps for both of these applications that the SLL is not a singular line, and that the SLL is not invariant to changes in gas composition. Re-calculation of these two maps into invariant $q_{sr}^2-h_{pr}$ coordinates result in both cases in the SLL collapsing into an approximately singular, compacted line (see Figures 8b, 9b) and in addition, the resulting SLL is nearly invariant to gas composition changes. All that is left to complete the design is to calculate characterizer $f(h_{pr})$ for implementation in the antisurge control system.

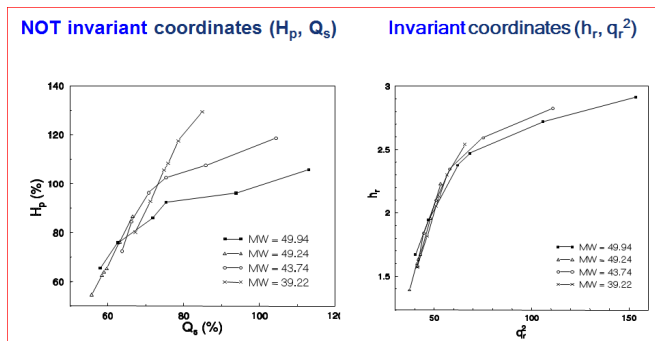

Figure 8a,b. Reduction of compressor maps for a variable gas composition into invariant coordinates, example 1.

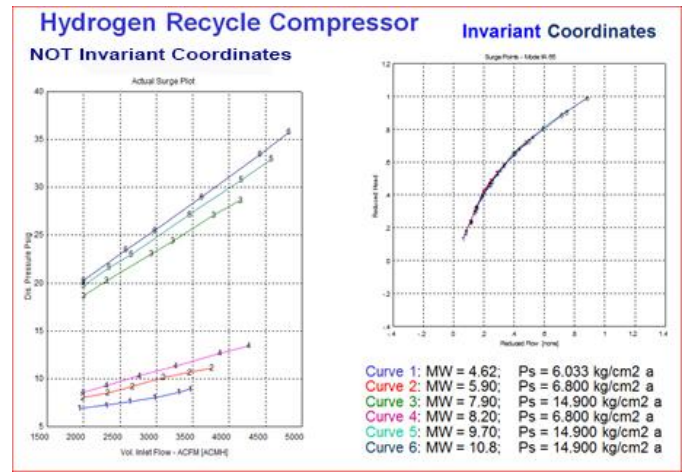

Figure 9a,b. Reduction of compressor maps for a variable gas composition into invariant coordinates, example 2.

As a side note: it is always recommended to include direct measurement of gas composition into the set of signals of the antisurge control system, if is available, for the follow up analysis of the system operation. Although the signal of gas composition (molecular weight for example) is not recommended for inclusion into the closed loop control system due to low speed and insufficient reliability, it is still very useful when evaluating quality of the operation of the antisurge control system as the gas composition is changing.

Flow Measurement in Discharge

Flow measurement in discharge is often used in compressor systems for various reasons. Installing the flow measuring device in the discharge of the compressor often is more economical and sometimes more practical, although the preferred location for the flow measuring device is still the suction of the compressor. To use it within suggested equations (10), signal of flow measuring device in the discharge of the compressor is converted to conditions in the inlet of the compressor using continuity of mass equations.

$$W = A_s \sqrt{\frac{dPos * Ps}{Zs * Ts}} = A_d \sqrt{\frac{dPod * Pd}{Zd * Td}} \quad (20)$$

From the equation (20) for suction and discharge, we can derive (to the accuracy of constant coefficient) value of the signal as it would be observed at the flow measuring device in suction of the compressor

$$dPos = dPod \frac{Pd * Ts * Zs}{Ps * Td * Zd} \quad (21)$$

In equation (21) all variables can be measured, except compressibility of gas. Compressibility Zs and Zd of gas in general are functions of local pressure and temperature and cannot be measured directly. Compressibility in equation (21) must be used as, available from reference, for conditions that are of most interest from the point of view of antisurge control,

such as pressures and temperatures at the most critical applications, or pressures and temperatures for the most probable surge scenario.

Alternatively, if the signals of temperatures in the equation (21) are not available, using a polytropic relationship between pressures and temperatures of gas, the equation (21) can be implemented as

$$dP_{os} = dP_{od} * \left(\frac{P_d}{P_s}\right)^{(1-\sigma)} * \frac{Z_s}{Z_d} \quad (22)$$

Comments to compressibility Z_s , Z_d made above apply to the equation (22), too.

It must be pointed out that both, equation (21) and, to a larger degree equation (22), suffer from loss of accuracy when applied to cases with variable gas composition due to effect of the pressure and temperature on compressibility. And further, equation (22) includes a ratio of specific heats of the gas, $k = C_p/C_v$, and efficiency of the compressor, η , both of which vary with gas composition as well.

Refrigeration Compressor with Side Streams

Refrigeration compressor with side streams presents an additional element of difficulty since direct measurement of flow is possible only for end-stages: in the inlet of the first stage and in the discharge of the last stage. It is impossible to acquire direct measurement of flow for mid-stages of the compressor.

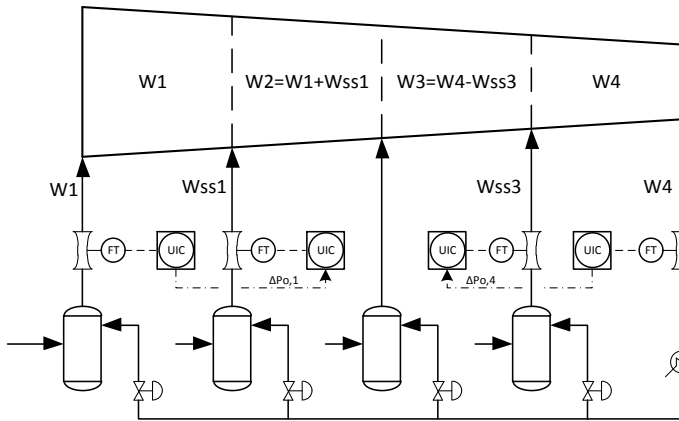

Figure 10. Layout of Refrigeration Compressor with Side Streams

As seen in Figure 10, direct measurement of flow for stage 2 of this refrigeration compressor is impossible and, therefore, a computation scheme is developed to obtain a “virtual” flow measurement for the inlet of stage 2 from measurements of flow in the inlet of the 1st stage and measurement of flow in the side stream of stage 2 using mass balance, as

$$W_2 = W_1 + W_{SS} \quad (23)$$

Expressing components of the mass flow equation (23) results in

$$A_{S2} \sqrt{\frac{dP_{OS2} * P_{S2}}{Z_{S2} * T_{S2}}} = A_{SS} \sqrt{\frac{dP_{OSS} * P_{SS}}{Z_{SS} * T_{SS}}} + A_{D1} \sqrt{\frac{dP_{OD1} * P_{D1}}{Z_{D1} * T_{D1}}} \quad (24)$$

For a typical refrigeration compressor pressures in the point of flow summation (Figure 10) are very close, and can be assumed equal:

$$P_{S2} = P_{SS} = P_{D1} \quad (25)$$

This allows to eliminate pressures out of equation (24), and further, equation (24) is multiplied by $\sqrt{Z_{S2} * T_{S2} / A_{S2}}$, resulting in

$$\sqrt{dP_{OS2}} = \frac{A_{SS}}{A_{S2}} \sqrt{dP_{OSS} \frac{Z_{S2} * T_{S2}}{Z_{SS} * T_{SS}}} + \frac{A_{D1}}{A_{S2}} \sqrt{dP_{OD1} \frac{Z_{S2} * T_{S2}}{Z_{D1} * T_{D1}}} \quad (26)$$

Direct measurement of temperatures and the associated compressibility in equation (26) is impossible, and further assumption is made that ratios of temperature and of compressibility in equation (26) are well behaved and that they remain reasonably constant within operating range of the refrigeration compressor. The temperature and compressibility ratios are then calculated as constants for design conditions of the compressor, and since the temperatures in the inlets of the compressor do not change much throughout operating range of the compressor, the assumption was proven to stand well in practical installations (additional analysis of variability of these ratios was also performed resulting in same conclusion). Continuing, the calculated temperature and compressibility ratios together with ratios of coefficients of flow measuring devices in front of square roots are replaced by constant coefficients and the equation (26) is squared resulting in

$$dP_{OS2} = C_3 * dP_{OSS} + C_4 * dP_{OD1} + C_5 * \sqrt{dP_{OSS} * dP_{OD1}} \quad (27)$$

where, dP_{OD1} in the discharge of stage 1 is calculated using available dP_{OS1} , P_{S1} and P_{D1} as

$$dP_{OD1} = dP_{OS1} * \left(\frac{P_{D1}}{P_{S1}}\right)^{(\sigma-1)} \quad (28)$$

Equations (27), (28) produce the “virtual” value of dP_{OS2} required for further calculations of the SLL for the stage 2 of the compressor in the same way as it would be if obtained from “real” measurements within desired accuracy as proven by numerous installations.

Similar sequence can then be repeated for the remaining stage 3 of the compressor, while stage 4 of the compressor can be processed using the strategy of re-calculation from the discharge to suction.

Surge Control Line (SCL) in Compressor Map in Invariant Coordinates

The remaining step for implementation of the calculations above in the antisurge control system is to produce process variable and set point. The preceding steps produced a normalized distance from surge variable S_s , which allows to calculate distance between the Operating Point and the SLL.

In reality, continuous operation in the immediate vicinity of the SLL is impossible due to the need for an additional surge margin to provide for the time required for the system dynamic response. The additional line, surge control line, SCL, is introduced for this purpose. SCL is shifted to the right of the SLL by the value of the surge margin, b_1 . The surge margin provides for sufficient time for the system to be able to respond to the disturbances and to “turn around” the operating point that is rapidly moving towards surge (see Figure 11).

It is obvious that the compression system will be operating with less recycle on average if the surge margin is smaller, and that a larger surge margin will increase system safety; but on the other hand, smaller margins increases system efficiency, while larger margins is making the system more wasteful. Thus, the surge margin is the ultimate expression of compromise between safety and efficiency of the compression unit and it needs to always be addressed from this perspective. To provide for usual conventions used in the control systems, one last step of calculations is performed.

$$DEV = 1 - (S_s + b_1) \quad (29)$$

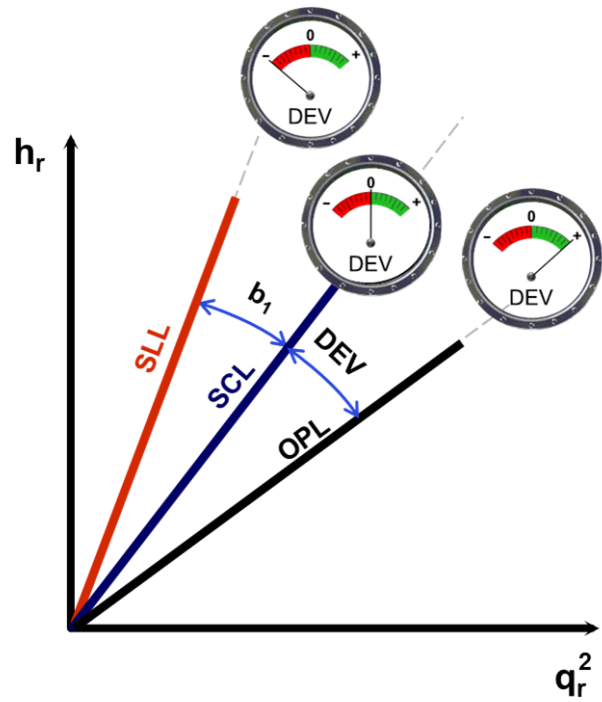
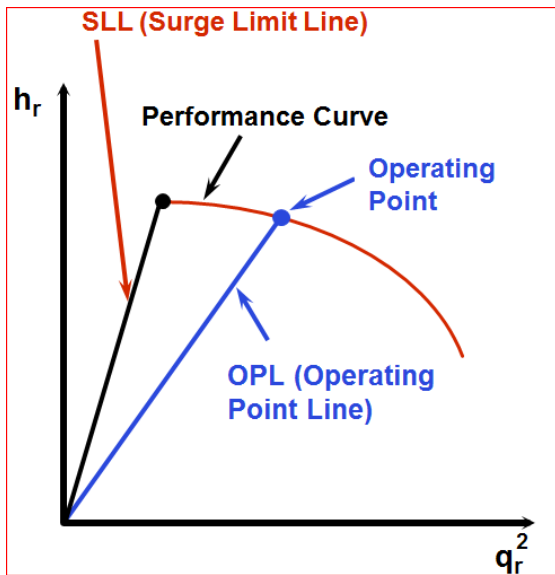

Figure 11. SLL and SCL and Deviation

Equation (29) expresses deviation of the operating point from the SCL in a manner comfortable and used traditionally by the operators of the process. As shown on Figure 11, $DEV=0$ when the operating point is located on the SCL; it becomes progressively more negative ($DEV<0$) as the operating point crosses the SCL and moves further into the surge zone, and deviation is becoming progressively more positive ($DEV>0$) as the operating point is located in the normal operating zone and moving away from surge.

Many users expect the surge margin to be equal to 10 percent of flow at the SLL, as based on their indiscriminate interpretation of various standards and literature sources. It is obvious that the surge margin equal to 10 percent may be too small in some cases, and too large in others. The surge margin of a specific system must take into account many factors, some of which are:

- Accuracy of the SLL data available for setting up the antisurge control system; the uncertainty of the SLL data available needs to be compensated by an increase in surge margin;
- Uncertainty due to errors in invariant representation of the SLL in the antisurge control system; the SLL may be defined perfectly well for some conditions, but it may deviate from reality for others;
- Differences in the shape of the performance curves of the compressor. For example, very flat refrigeration compressor curves (high MW and high Mach number) may need a more generous surge control margin than steeper curves.
- Uncertainty due to limited accuracy of transmitters and flow measuring devices, and methods of their installation;

- Time necessary for the dynamic response of the antisurge control system and other dynamic properties of the system, including the type, size and frequency of disturbances;
- The desired antisurge control objective; in some cases infrequent surging of limited duration is accepted, and in others, surge is to be avoided at any cost.

With all factors taken into account, it is impossible to predict whether 10 percent will be satisfactory for a specific system. Some predictions may be made by the use of dynamic simulation, and only final site testing allows to establish adequate surge margin for a specific system.

In the preceding steps, for the Antisurge controller we defined the process variable that allows to measure and express the distance of the operating point from the SCL and, the Set Point for this control function that is equal to 0 when on the SCL. When the $DEV > 0$ the antisurge control action is not required and the expected output of the antisurge controller should be 0, $DEV = 0$ indicates that the antisurge controller is actively controlling position of the operating point by manipulating position of the recycle valve, and $DEV < 0$ indicates that the operating point is to the left of the SCL, with large negative DEV indicating that the compressor may be operating in or dangerously close to surge.

Overall considerations

The preceding discussion may leave an impression that the proposed guide lines and set of strategies produce satisfactory results in all cases by just following the recommended rules. This is not always the case, and the designer of the system must be aware of that and be prepared for possible problems:

- Accuracy limits due to the compressor map coordinates being only “nearly” invariant. As mentioned above, the “near” invariant coordinates were derived on accepting certain assumptions for reduction of variables Q_s and H_p into their “nearly” invariant related parameters q_{sr}^2 and h_{pr} . Additional error here will be introduced due to omitting variability because of changes in discharge compressibility, Z_d . This implies that there may be some additional error between the SLL, as implemented in the control system vs. the actual SLL of the compressor, as tested on site.
- The compressor map in coordinates Q_s-H_p was used above and it was assumed that available maps cover all expected compressor operation. Often the compressor has to operate outside of the set of compressor maps supplied with the machine. The challenge to the designer of the antisurge control system is how to interpolate, and sometimes, extrapolate the SLL data for conditions not presented in the available compressor maps. Literature (Boyce, 2003, Lapina, 1982, ASME PTC 10-1987) offers a number of methods, some standardized, on how to re-calculate compressor operating maps from one set of conditions to another, but the same literature also defines the magnitude

of possible error when performing these recalculations. Caution must be taken when implementing this re-calculated data for compressor protection.

- Ultimately, the preceding explanation of how to set up the most appropriate implementation of the SLL in the antisurge controller only explains how to choose the path to the best solution for a given application. The rational selection of the solution is obviously up to the designer of the antisurge control system, and the economics of the solution must be also considered. The decision, as always in these cases, must be made between initial, capital outlays and long term, lifecycle cost. Less expensive, simpler antisurge control systems may end up wasting energy and will cost more in long term energy consumption, or compromising safety of the compressor.
- There is a lot of a discussion on whether to perform surge testing in field. In the opinion of the authors, there is no doubt that every antisurge control system must be tested in field, firstly to demonstrate the ability of the system to perform as expected, and, secondly, if it is necessary to establish the actual SLL of the compressor.

ANTISURGE CONTROLLER STRUCTURE

An antisurge controller must be capable of responding to many different transient scenarios and it should also be able to operate accurately in a steady state condition with, or without continuous recycle. In the case of a typical compressor, a sudden loss of feed gas may cause surge if the antisurge controller does not respond quickly enough. If low flow conditions persist, then the antisurge controller must maintain a stable position on the surge control line and make small adjustments to the valve position to maintain the minimum required surge flow. Because of this very wide range of operating scenarios, an antisurge controller needs to have a complex structure. Performance objectives of the antisurge controller must be formulated in terms of: accuracy of operation when in vicinity of the surge control line, combined with high speed of response when operating with large, sharp load disturbances.

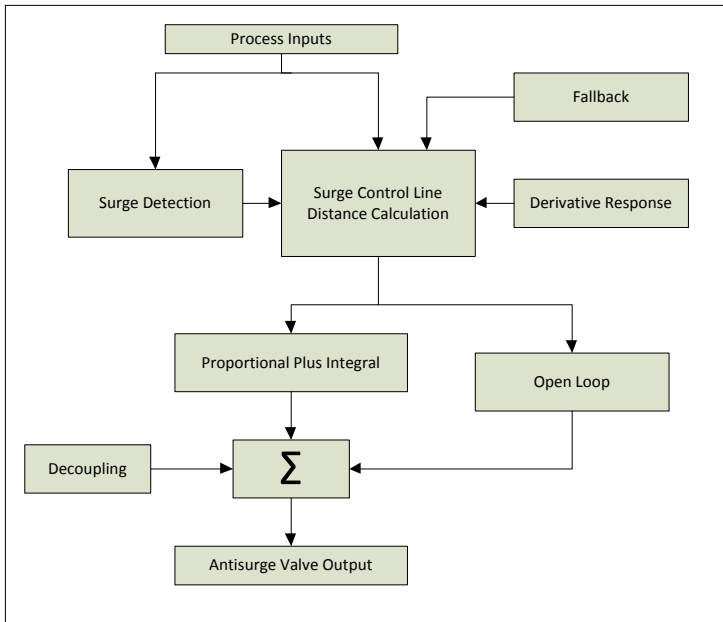

Figure 12. Antisurge Controller Structure

The structure of an antisurge controller is shown in Figure 12. The proximity to surge (deviation) is calculated from process inputs and then adjusted based on an adaptive response (surge detection), a derivative response, and fallback calculations. Once the control error has been calculated, a proportional plus integral (PI-control) calculation is applied. If the negative deviation towards surge is large enough to warrant a stronger, more powerful response, an open loop response is added. Finally, a decoupling signal from peer controllers is added to calculate the final output to the control valve.

Proportional Plus Integral Control

The core component of an antisurge controller is the PI-control calculation. The proportional part increases linearly as the error increases. The integral part (sometimes referred to as reset) increases as the time integral of the error. For antisurge control, error is defined relative to the surge control line:

$$e = 1 - S = DEV \quad (30)$$

where S is the distance to surge as defined in earlier chapter. The PI-control response is then:

$$CR_{PI} = Kp (e + Ki \cdot \int e \cdot dt) \quad (31)$$

The PI controller is a standard control algorithm that is generally used in the field of industrial controls. The proportional part (P-part) is intended to provide a sound dynamic response, where the integral part (I-part) eliminates offset due to the operation of P-part and maintains the set point with precision. The common tuning challenge in general, is to have enough proportional response to provide quick action, while the integral reset rate needs to adequately trim the valve position without continually hunting around the set point.

PI-control in the antisurge context is unacceptably slow. The integral part is not capable, nor is it intended to, provide a sufficiently large quick response. The proportional response near surge is limited. Consider the typical scenario of a 10 percent flow margin between the Surge Control Line and the Surge Limit Line. If the valve needs to be open to 50 percent stroke to guarantee surge protection, then the antisurge controller would need a nominal gain of more than 5 to produce the desired response. In practice, this high gain is impossible in the antisurge control systems because it would cause instability, while continuously operating on the surge control line. Typically a nominal gain of less than 1 is used to ensure stability in an antisurge controller. Therefore, PI-control is limited by stability requirements and will not be able to meet the high speed performance objectives of an antisurge system.

Open Loop Response

Because of the limited expected performance of PI-control, an open loop response is used to supplement the action of PI-control. When the deviation grows to a predefined level, the open loop response is triggered. Figure 13 illustrates the line that determines where the open loop response is activated. As the operating point moves left past the Surge Control Line, the antisurge valve opens on action of PI-control. If the operating point continues to move left and reaches the open loop line, then an open loop response is triggered and added to the already accumulated PI- response. Typically, the open loop line is placed near the middle of the surge control margin. However, field tuning ultimately determines the value of the distance.

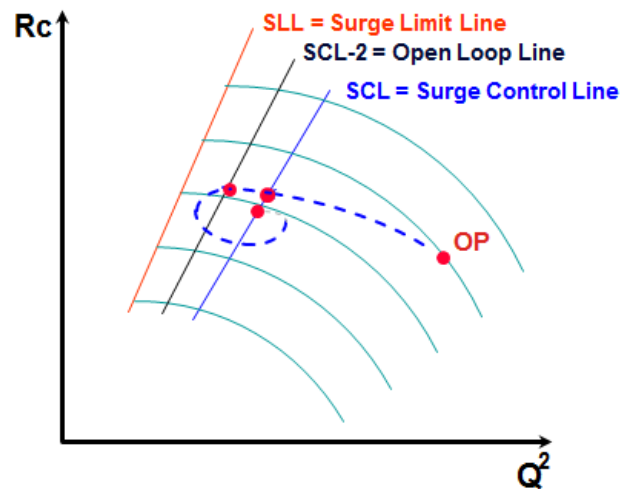

Figure 13. Open Loop Response Line

The magnitude of the step open loop response is based on the derivative of deviation at the time the operating point crosses the open loop line. This calculation method produces large step responses when the operating point is approaching surge rapidly, and smaller responses when the transient is less severe. In practice, the derivative of deviation is difficult to measure for all scenarios, so the minimum and maximum response from this calculation is clamped. The field service

engineer uses the best tools available to estimate the range of derivatives the compressor will see, and the gain is based on that assessment.

$$CR_{OL} = Td_{OL} \cdot \frac{dSs}{dt} + Min_{OL} \quad (32)$$

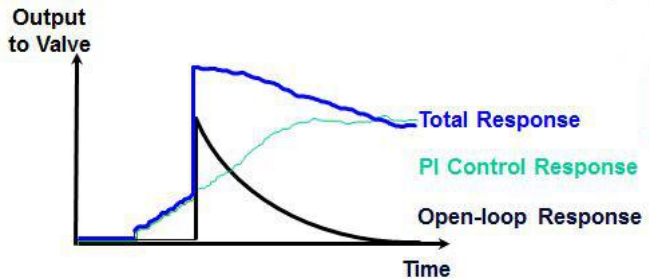

Figure 14. Open Loop Response

The open loop response (see Figure 14) will continue to repeat after a certain time period if the prior step response fails to increase the flow and/or reduce the head enough to move the operating point to the right of the open loop line. The valve then continues to “ratchet” open until the operating point moves to the right of the open loop line. At this point, the open loop portion of the response is slowly reduced through an exponential decay function. Use of the exponential decay of the sufficiently large step response is necessary to guarantee a smooth, bumpless transfer from open loop response that provided the necessary speed of protection back to “normal” operation under PI-control.

Derivative Control

Earlier, proportional plus integral control was described without mention of the derivative term, which is usually part of a PID-control loop. In a standard PID loop, the rate of change of error between the set point and process variable is calculated, multiplied by some factor, and added to the controller’s output. Signal noise, as a result, is usually amplified to the extent that this portion of the control response is useless because the output simply reacts to noise rather than to a real disturbance. Additionally, the traditional implementation of the derivative would slam the valve in closing direction as fast as the opening was, which is completely unacceptable. Antisurge control has little use for this particular type of derivative control.

Derivative control in an antisurge controller works differently than in the standard PID control loop. Derivative control in an antisurge controller increases the safety margin based on the peak rate of change in flow. Notice that only the peak rate is observed. By measuring the peak rate, the safety margin is increased only when significant transients are measured. The peak rate is slowly ramped down so that the derivative response is reset until the next transient. The result is that the derivative part of the algorithm has effect on the output only when the operating point is located near the SCL; the operating point does not attempt to open the antisurge valve when the operation occurs far away from the SCL; the

antisurge valve opens earlier when transients are high in vicinity of the SCL, and stays closed longer when transients are no longer present.

Another benefit of this type of derivative control is that less flow margin is needed between the surge line and the control line. In other words, if flows and pressures are reasonably steady then a properly tuned PI- control is adequate to be used alone. As disturbances increase, derivative control shifts the control line to the right. Therefore, PI-control has more room to overshoot when transients exist, and the compressor has more turndown when the system states remain relatively unchanged.

Surge Detection

Surge detection algorithms are used to alarm operators and to possibly shut down a compressor when all other methods of surge prevention have failed. A compressor’s surge limit line will, over time, shift because of slowly deteriorating performance. As the surge line changes, the controller will have less time to react because the distance between actual surge and the controller’s surge control line will decrease. If the compressor surges as a result of its shifted SLL, then the antisurge controller clearly needs to adapt its configuration by increasing the safety margin. This adaptive action prevents further surging by causing the antisurge controller to open the recycle valve at a higher flow rate.

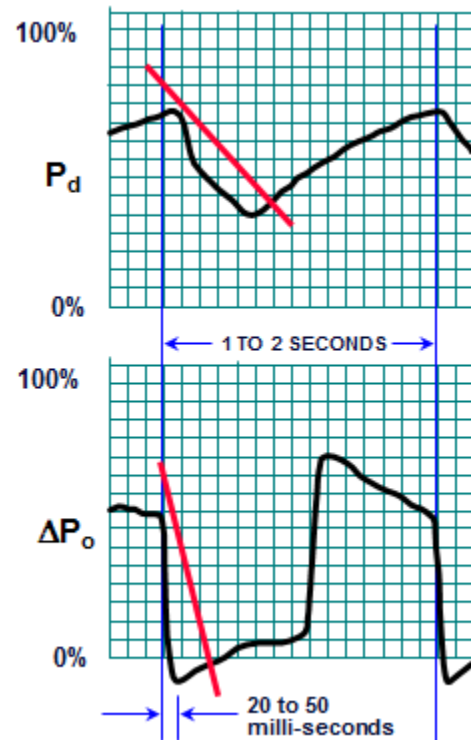

Figure 15. Surge Detection

Because of its use as an independent layer of defense,

surge detection must use something other than the surge limit line as a measure. Various ideas related to vibration and special instrumentation have been proposed as new, additional methods for surge detection, some of which show great potential. However, the current “accepted practice” methods used for surge detection are:

- Rapid change in flow (See Figure 15)
- Rapid change in pressure (See Figure 15)
- Rapid increase in temperature
- Rapid change in driver power
- Combinations of items 1-4

There are significant differences between surge detection and antisurge control that should be noted. Antisurge control serves the purpose of preventing a compressor from surging. Surge detection has the purpose of identifying that surge has occurred or that a compressor is operating at the onset of surge. Surge detection methods are used in an antisurge algorithm to enhance and adapt the distance from surge line calculation. A separate surge detector is used as an independent protection layer.

Separate Surge Detection as part of the expected 5th edition of API 670 Standard

The topic of Surge Detection that makes up the adaptive feature of the antisurge control algorithm, as discussed in preceding paragraphs, overlaps with the expected changes in API 670, 5th edition Machinery Protection Systems.

The 5th edition is expected to have major additions as it relates to surge detection. The standard is in the process of approval, but one expected change is that independent surge detection for axial compressors will be a requirement going forward. Centrifugal compressors (both inline and integrally geared) will also be considered as candidates for independent surge detection if it's specified or, if the consequence of surge related damage is unacceptable as defined by the end user or OEM. In any application for which the consequence of surge related damage is unacceptable, such as machines with high pressure ratios or power densities, an independent surge detection system may be justified. Compressors with multiple process stages may need surge detection on each stage.

Similarly to an independent overspeed trip device that is currently required by API 670, independent surge detection may become a requirement as well. The independent surge detection is being considered in addition to the expectation of having antisurge control system used for protection of axial or centrifugal turbomachinery.

Due to instrumentation malfunctions in transmitters or control valves, compressor fouling, or failure of the antisurge control system a compressor may encounter multiple surge events. If the antisurge control system is unable to prevent surging, then a surge detection system should be used to independently detect surge cycling and take action to avoid

severe compressor damage. These surge detectors should use independent transmitters and independent hardware platforms to avoid common mode failures. If the antisurge control system incorporates redundant transmitters and redundant control elements, it may be allowable for the surge detection function to be included in the antisurge control system.

Dedicated antisurge control is viewed as the first line of defense to prevent surge events and is not addressed directly by API 670. It's only after the primary antisurge protection is not effective that independent surge detection is expected to protect compressor from the surge related damage. If an antisurge control system is properly designed and maintained, machinery damage due to surge events is typically avoided.

The standard allows for multiple surge detection methods, similar to the ones listed above, and the surge detection system can incorporate more than one method.

The surge detection system should incorporate a surge counter that increments for each surge cycle. If more than one detection method is used, the surge detection system can only be allowed to identify one surge count per surge event.

The surge detection system would have two outputs, one for surge alarm and one for excessive surge. The surge alarm will be activated when a surge event is detected. The excessive surge output will be activated when a specified consecutive number of surge cycles are recorded within a specified time frame. The excessive surge output would be tied directly to the ESD system to trip the compressor or antisurge valve.

Loop Decoupling

Control loops are said to be coupled (also often used is the term, control loops are interacting) when the control action of one loop causes the process variable of another loop to change. Consider the antisurge control loops in Figure 16. If the downstream recycle valve opens, the increased flow to the suction of that stage will cause the pressure to increase. However, the suction pressure rise in the second stage will also cause a discharge pressure rise in the first stage. When the first stage discharge pressure increases, the first stage recycle valve will need to increase the flow of that stage to avoid surge. Because the first stage controller has to react to disturbances caused by the second stage controller, the loops are coupled, or are interacting. The actions of these two controllers may continue, because opening of the controller of the 1st stage will improve condition of the 1st stage, but it will make condition of the 2nd stage worse. The interaction between these two control loops cause the system (at best) to demonstrate oscillatory response, and in some cases systems of this type may become unstable, causing the operator to switch part or all of the control system into a potentially dangerous manual mode.

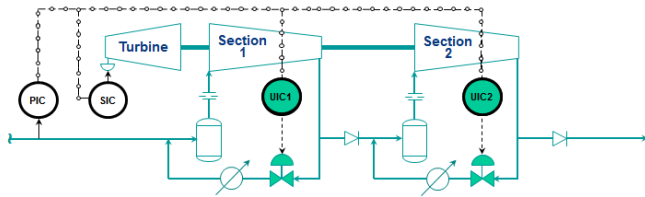

Figure 16. Loop Decoupling Between Antisurge Controllers

A decoupling control algorithm is designed to reduce and eliminate the interaction between the loops. Decoupling is achieved by adding a portion of the output of controller A (UIC-1) directly to the output of controller B (UIC-2). As a result, controller B actually begins its control action before it sees the disturbance caused by controller A's output. Ideally, this preemptive, feed forward control action would be just enough to cancel the upcoming disturbance caused by controller A's output. In this ideal case, controller A could position its valve in any fashion, and control loop B's dynamics would remain unchanged. Thus control loop B would be completely decoupled from control loop A.

Fallback Modes

A fallback mode is an alternate way to calculate a variable when certain data becomes unavailable. Most fallback modes are triggered by a failed transmitter and are intended to provide safe, and typically more conservative control until the failure is corrected. As an example, the reduced polytropic head calculation for distance to surge uses flow, temperature, and pressure transmitters. If one or more transmitters fail, then obviously an alarm is generated and the fallback mode is decided by the following logic:

- If a temperature transmitter fails, calculate proximity to surge using only pressures and flows.
- If a pressure transmitter fails, calculate proximity to surge using a minimum flow.
- If the flow transmitter fails, open the antisurge valve to the maximum of:
 - Its current position and
 - A configured minimum value.

Fallback strategies provide enhanced system availability. In the fallback decision tree, there is no logic path for shutting the compressor down. The antisurge controller is structured to provide machinery protection even when certain inputs fail. By providing an alternate method to control when certain parts fail, the compressor can run longer than if the failed input caused the machine shut down.

Overall System Dynamics Considerations

An antisurge control system must be designed to handle any transients that might occur while the compressor is operating within its defined operations envelope (see Figure 2). Nevertheless, the antisurge control system often is presented with challenges that cannot merely be addressed by control

algorithms alone. Operation during fast transients, such as ESD, might require additional equipment (e.g. valves, piping, and transmitters) to avoid surge. For example consider a system where the recycle piping is, by layout necessity, comparably long. In this case, the antisurge system alone will not have the capability to prevent surge during harsh ESD transients because the system dynamics of lengthy pipe runs are too slow to be compensated for by the electronics themselves. In this case a shorter (often termed "hot-bypass") recycle pipe run might need to be installed along with the necessary valves and instrumentation which is used for the sole purpose of preventing surge during these harsh transient scenarios. This additional hot-bypass system needs to be carefully integrated so its control action will not conflict with the main antisurge control system. As a general requirement, the antisurge control system must be able to accept signals from the ESD and other safety oriented systems protecting the compressor in order to synchronize its actions with these protective systems.

COMBINED ANTISURGE AND PERFORMANCE CONTROL

The throughput control method has a significant impact on the antisurge control system. Consider a few examples: if inlet guide vanes are used, then the antisurge control system should have inputs and specific characterizations for the guide vane position; if turbine speed is controlled, then the antisurge control needs to be integrated to avoid control loop interactions. In every case, the antisurge and throughput control are interrelated because they both influence the same process variables and the same position of the operating point in the compressor map.

The selection of the compressor drive primarily depends on size (i.e. power) requirements and available sources of energy. The throughput control method is usually predetermined by the drive type. For instance, steam turbines are often used at refineries and petrochemical plants because the processes used often produce excess heat that is further used to produce drive steam as well. In these cases, turbine speed often becomes the *de facto* method of throughput control because the speed can easily be governed with steam flow.

Compressor Throughput Control Methods

A constant speed electric motor driven compressor, controlled by a suction throttle valve, provides a simple solution. The startup controls are relatively straightforward and there is no warm-up sequence, as might be needed in a steam turbine. No over speed protection is needed. However, the cost of electricity can be relatively high and throttling inherently wastes energy. Therefore, constant speed electric motor driven compressors with throttling used for control are not necessarily the most energy efficient, but are simple to start and operate.

A constant speed electric motor driven compressor, controlled by a discharge throttle valve, has similar characteristics to that of a suction throttle. Both are relatively easy to operate and maintain. However, for an equivalent

reduction in throughput, suction throttling uses less power because the inlet gas density is reduced. Additionally, discharge throttling has substantially stronger negative effect on the antisurge control than the suction throttling. Therefore suction throttling is recommended over discharge throttling as a compressor throughput control method.

Constant speed compressors controlled by inlet guide vanes are more complicated than suction throttle machines, but are also more efficient. Inlet guide vanes effectively change the compressor performance characteristics at each vane angle. Therefore as the guide vanes open, not only does the flow increase but the performance curve steepness and surge flow changes as well (see Compressor with Inlet Guide Vanes on page 8).

Applications using turbine driven compressors are usually more efficient than throttled compressors because of the losses associated with throttling. The machine speed is varied until the flow requirement at a given pressure ratio is met. However, turbines (gas or steam) require complicated start-up and warm-up sequences. Over speed protection controls are also required on turbines.

Variable frequency drives (VFD) provide an efficient means for starting and controlling the speed of an electric motor. As technology improves, such drives have gained in popularity. Grounding and harmonic vibrations are some of the main issues associated with VFD's.

Electric motors can also vary the drive speed through a fluid coupling. Guide vanes are used in the fluid coupling to control the amount of transmitted torque. By varying the torque to the compressor shaft, speed can be controlled. Closed loop speed control greatly improves the response time and accuracy of this throughput method. Absence of speed control leads to the compressor operating at fluctuating speeds as the load changes, and thus results in poorer quality of throughput control and possibly a negative impact on the capability of the antisurge control to protect the compressor. Drawbacks of this approach are loss of efficiency and increased machine complexity.

Loop Decoupling

As mentioned previously, loop decoupling is an important part of an integrated control system. The previous discussion was on the benefits of loop decoupling between antisurge peers, and here the benefits of decoupling between the performance controller and antisurge controller is investigated. Loop decoupling between a performance controller and antisurge controller is important because the antisurge controller is essential to control flow in proximity to the surge limit line in the compressor map. At the surge control line, which is located in vicinity of the surge limit line, very small changes in pressure may cause large changes in flow. This increases the effect the antisurge controller (UIC), through operation of the recycle valve, will have on the parameter - like pressure, or flow that is being controlled by the performance controller (PIC) in controller interactions (see Figure 16).

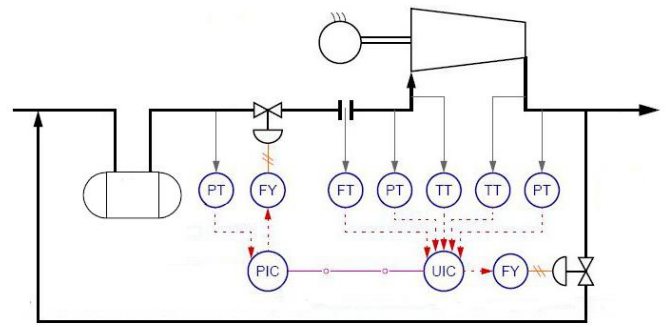

Figure 17. Loop Decoupling Between Antisurge and Performance Controllers

The first example of loop decoupling is between a throttle valve and the antisurge valve. In many cases, piping designs have the suction throttle inside the antisurge loop as shown in Figure 17. As the antisurge valve opens, pressure builds in the suction drum. As the suction drum pressure builds, the performance controller opens the inlet throttle valve to maintain the pressure. When the performance controller opens its valve, more flow is introduced into the loop. The antisurge controller then closes the recycle valve to compensate for this extra flow and the cycle repeats. The described interaction negatively affects the quality of control of the process variable, pressure in this example, making the system behavior more oscillatory, and potentially unstable. This negative interaction also affects the antisurge control by allowing wider excursions of the operating point towards the surge limit line.

A solution to this problem is to feed forward the antisurge control output to the performance controller. This feed forward control action eliminates controller oscillations caused by all of the piping and drum volumes between the antisurge valve and the suction throttle valve. Consider the previous example with loop decoupling implemented. As the antisurge valve opens, the performance control receives a feed forward command to open its valve as well. The additional gas flowing into the suction drum due to the increase in the recycle valve opening is immediately offset by the increase of the outflow from the suction drum by an increase in the opening of the inlet throttle control valve. Because the suction drum pressure remains constant, the performance controller does not need to act on an additional error through its PID-algorithm. As a result of decoupling, the antisurge controller (UIC) is free to maintain position of the operating point relative to the surge limit line without disturbing the controlled variable of the performance controller (PIC).

It is worth mentioning that for the common piping arrangement used in the prior example, the suction throttle valve should have a mechanical minimum stop. The reason for this stop is to ensure operability of the antisurge control system during periods of low load. Typically this stop is initially implemented at a 15 percent valve opening, although the final value is determined at commissioning.

The next example is the interaction observed on a

variable speed machine and the antisurge loop. Figure 18 illustrates a control interaction scenario where the compression train flow is reduced to the point where the antisurge valve must open. Starting at point A, the flow reduction causes discharge pressure (P_d) to increase. To maintain the controller set point, the machine speed must decrease. When the speed decreases to point B, the recycle valve must open to maintain position of the operating point on the surge control line. At this point, the speed control loop and antisurge control loop have conflicting goals: one controller acts to decrease the machine flow while the other acts to increase it. The overshoot illustrated in Figure 18 can be greatly reduced through loop decoupling. At point B, a portion of the antisurge output is added to the control response of the speed controller to help offset the conflicting control actions. The overall result is the operating point moving from point B to point C without overshooting the set point while maintaining a further distance from the Surge Limit Line.

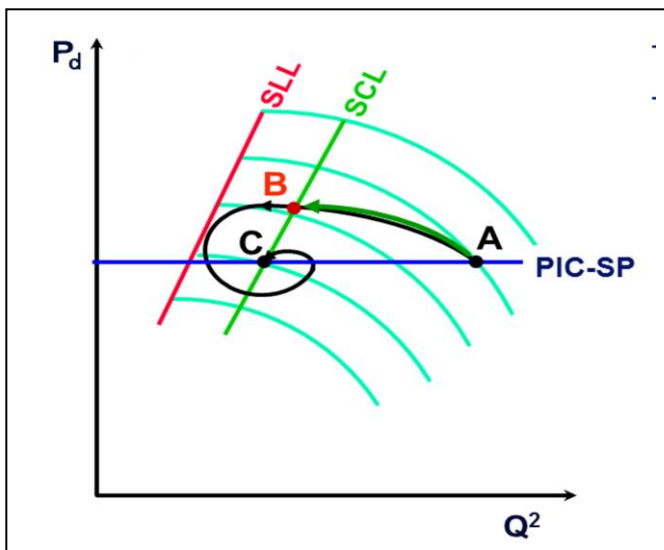

Figure 18. Control Loop Interactions with a Speed Controller

Parallel Train Operation

Often, multiple compressors will work in parallel to meet the design requirements of a particular installation site. For instance, LNG plants might use three propane refrigeration compressors in parallel rather than one large machine. The machines can be sized so that the plant can operate with two out of three machines running while one machine is being serviced. Additionally, if the plant load is greatly reduced, machines can be taken off line. Using multiple machines greatly increases the flow range that can be handled by a particular installation. However, controlling parallel compressors to efficiently and effectively meet the process goals can be a challenging task.

The first objective of parallel operation is control of the main process variable. This main process variable is usually suction header pressure, discharge header pressure, or compressor mass flow. The problem with multiple compressors trying to control, say, suction header pressure is that there are

too many degrees of freedom. For example, suction pressure header could possibly be maintained with one train fully loaded while the other train is in full recycle. The same suction header pressure could also be maintained by both machines operating at part load. If each train uses an independent controller to maintain a common suction header pressure, the two controllers will constantly oscillate back and forth.

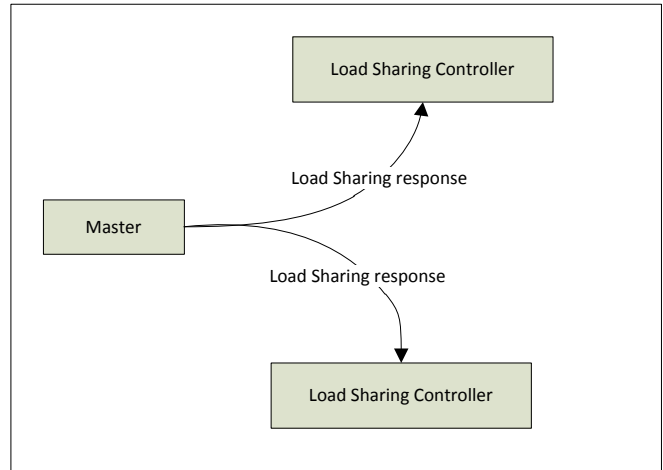

Figure 19. Load Sharing response

To maintain the main process variable, a single master controller needs to manage the main control variable. By using a single controller, the degrees of freedom are reduced to one: one control output is governed by a single input. If the master controller needs lower suction header pressure, it commands both load sharing controllers to increase its output by an equal amount. This control architecture guarantees that both compressor trains are intended to move in the same direction to meet the main process goal. Figure 19 shows a block diagram of the Load Sharing response.

The parallel control strategy thus far hasn't solved the problem of balancing the trains. Since no two compressors are exactly alike, the control system must take into account that each compressor will handle flow differently. The point/flow at which a compressor surges is one of the best indications for the machine's ability to handle flow. If one compressor is on the verge of surging while its peer has twice the surge flow, then clearly the best solution is to take flow from the latter and send it to the former. Eventually, the optimal point would be reached when each machine is as far away from surge as possible, and both are located at the same distance from their surge line. Therefore equalizing the relative distance from surge, or deviation, is the best means for distributing flow amongst parallel compressors. This strategy guarantees minimum overall recycle of the group of compressors, thus providing for the most efficient operation. This same strategy also guarantees the most effective antisurge control, because in the case of a disturbance, all compressors in the parallel system begin to open their recycle valves at the same time - without leaving one of the compressors behind, thus endangering it.

In order to balance the trains based on Deviation from SCL, the antisurge controllers are included into the control

strategy. On each train, all stages of the train report their distance from surge to the local performance controller. This local performance (Load Sharing) controller then applies some logic (usually the minimum of the reported distances) and reports the result to the master controller. The Master controller then uses the average of the reported deviations as a set point command to each load sharing controller. Figure 20 illustrates the load balancing control strategy.

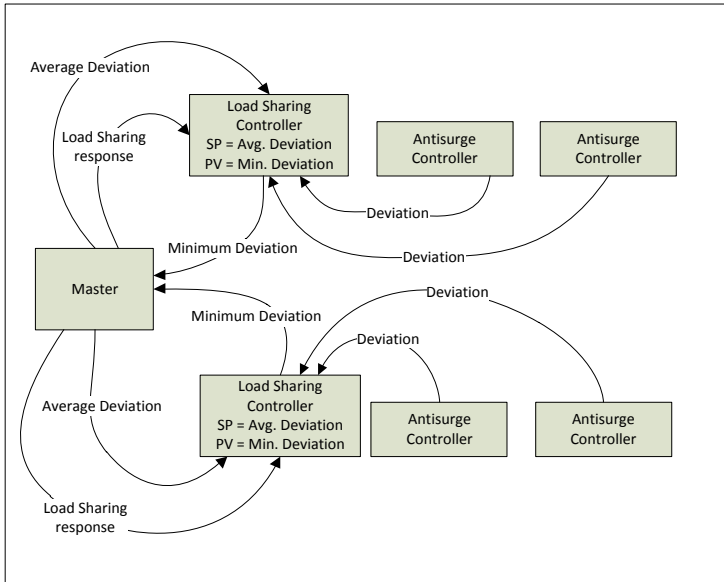

Figure 20. Parallel Load Sharing and Load Balancing

In practice, the single master controller sends two signals to each of the associated train controllers. The first signal is a direct command to increase or decrease the controller output depending on the needs of the main process variable control. The second signal is a set point that is the average distance of all compressors from surge. The overall output from the load sharing controller is then the sum of its own PI-control loop used to balance the deviation, and the load sharing response from the master controller used to maintain the primary process variable.

PIPING DESIGN CONSIDERATIONS

Piping system around the compressor must be designed to minimize the volume in the compressor discharge, between the compressor discharge flange, the inlet of the antisurge valve and the non-return (check) valve as much as possible. Large gas volumes act as energy storage, slowing recycle response times and increasing danger to the compressor during execution of protection cycle. Additionally, it is useful to note that the degree of damage to the compressor in an undesired case of compressor surge depends on the volume of gas in the compressor discharge. The relationship is pretty straightforward, the higher the volume, the longer it will take to pass back through the compressor, and consequently, the higher the damage to the compressor internals.

The recycle take off line should be located as close as

possible to the compressor discharge. A check valve needs to be installed directly after the recycle take off line.

Recycle Cooling

Recycle cooling is often required to prevent overheating during extended periods of recycling such as during startup, turndown operation or controlled shutdowns.

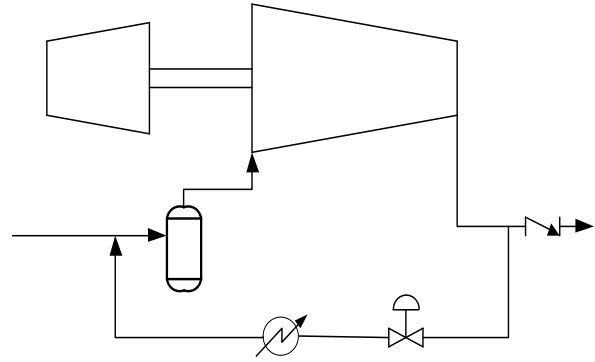

Figure 21. Cooler in recycle line downstream of the ASV

Coolers installed downstream of the antisurge valve (ASV) are preferred as this helps minimize the discharge volume. When utilizing coolers downstream of the ASV, knock out drums may need to be located downstream of the coolers, between the cooler and the compressor, to avoid liquid condensates from entering the compressor (See Figure 21).

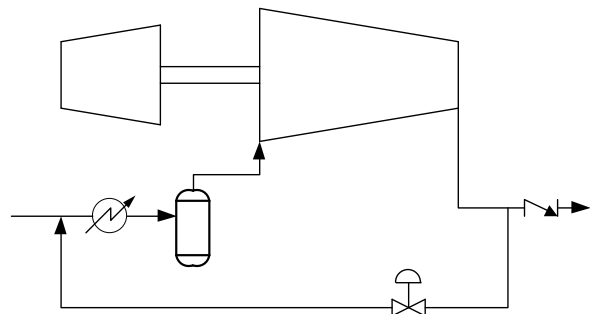

Figure 22. Recycle path utilizing cooler upstream of the compressor

Use of the production cooler located in the suction of the compressor often leads to very good results. As seen in Figure 22, this recycle piping layout also produces minimal volume in the discharge, and attention may need to be paid to these cases when volume in suction becomes important for assessment of dynamics of the system.

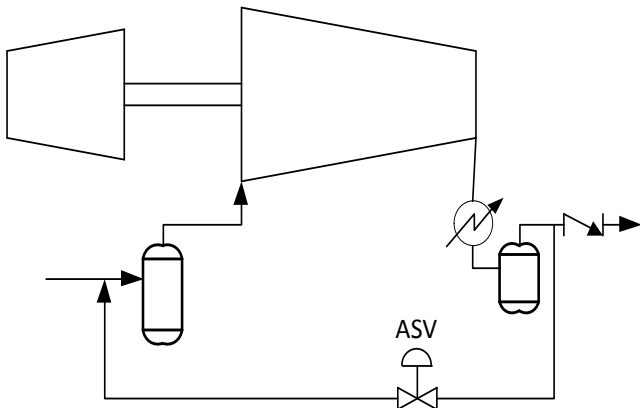

Figure 23. Recycle path utilizing compressor discharge cooler.

A less satisfactory recycle cooling layout can be achieved by utilizing a compressor discharge cooler. However, this will add to the discharge volume of the system which can result in the need for increases in antisurge valve capacities. To minimize the volume, the recycle take off should be located directly after the discharge cooler. Unfortunately, this is often not desirable because the gas downstream of the cooler in the discharge may contain condensed liquid that may damage the working body of the antisurge valve due to liquid erosion. Because of this recycle piping system, an addition knock drum is often needed between the cooler and take-off of the antisurge valve, as shown in Figure 23. This further increases the volume and resistance in the recycle path.

Recycle path constrictions

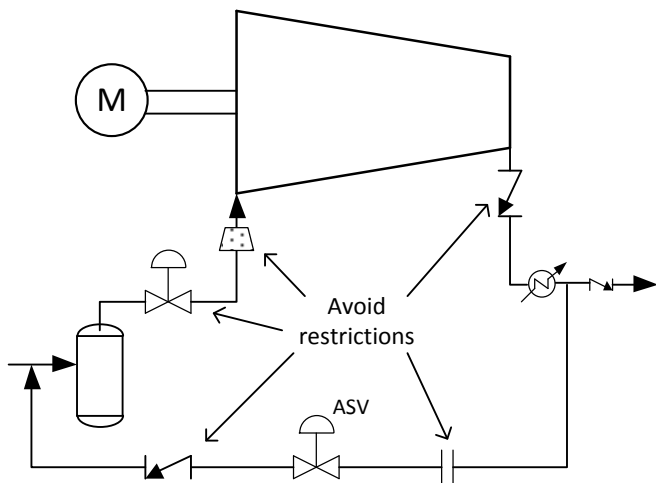

Figure 24. Recycle path restrictions

Restrictions in the recycle path can have negative effects on the antisurge control system. Suction strainers, suction throttling valves and flow measurement devices have the potential to restrict the recycle flow. See Figure 24 above.

Suction strainers are typically installed temporarily and then later removed after initial runs. Permanent strainers can clog over time and restrict flow through the compressor.

Permanent strainers, as well as temporary strainers, require additional instrumentation to measure the pressure drop across the strainer in order to determine if the strainer is becoming clogged.

Suction throttle valves should be installed upstream of the recycle path intake. Throttling downstream of the recycle path intake may be necessary, for example, to prevent high motor current during the startup of the compressor, a minimum mechanical stop should be incorporated on the valve to ensure that there will always be the necessary recycle flow to the compressor in case of valve failure or accidental closure.

Flow measurement devices are sometimes installed in the recycle line to measure the amount of recycle flow. Flow measurement devices with high permanent pressure loss should be avoided. An alternative method of measuring recycle flow is to install the flow measuring device downstream of the recycle line take off and subtract this flow from the compressor throughput flow measured by the antisurge control system.

Some compressor manufacturers may require a check valve to be installed directly after the compressor's discharge flange to prevent reverse flow through the compressor. In these cases, a non-slam type check valve should be used. Check valves located in the recycle line should be avoided as there is the possibility of the check valve becoming stuck closed and preventing recycle flow.

Multi-case compressors

Multi-case compressors as shown in Figure 25 are among the most complex compressors in use. The equivalent of two or more machines driven by a common driver, they can produce large compression ratios and are used extensively in wet-gas, gas gathering, and other applications. Although the below discussion focuses on two stage compressors, three, four, and more stage multi-case compressors are commonly used throughout the industry as well. These compressors can have complicated piping designs depending on the process requirements.

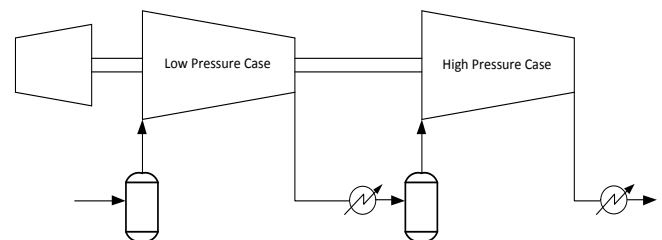

Figure 25. Typical two stage multi-case compressor

Even though all rotors are driven by the same driver, each stage has its own unique set of operating variables and disturbances to contend with. Efficiency, inlet and outlet temperatures, and pressures, gas composition, specific heat ratio, and compressibility all figure into the problem, yet vary from stage to stage. Each stage can surge independently of the others and must be protected as if it were a separate machine. For the fastest response, each compressor section should have

its own recycle line with a cooler and be controlled by an individual antisurge control loop reflecting properties of this compression stage, as shown in Figure 26. As discussed above, existing process coolers can be used as well.

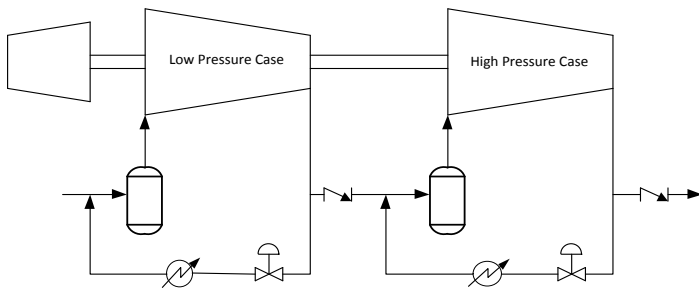

Figure 26. Two stage compressor with individual recycle paths

Examples of Compromised Piping Designs

Figure 27 illustrates a two-case machine in which both recycle lines are cooled by the same heat exchanger. Although this reduces capital and installation expenses, the large common cooler required by such an arrangement tends to bring additional, sometimes unacceptably high, dynamic instability between the two antisurge control loops.

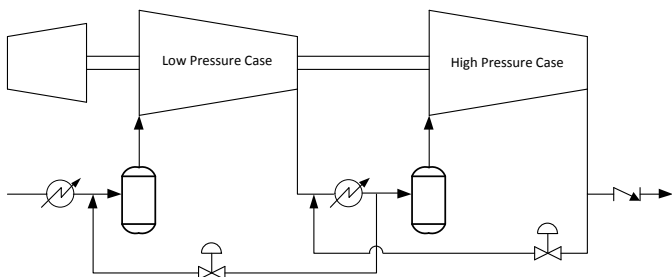

Figure 27. Recycle cooling using common inter-stage cooler

For example, when the antisurge valve for the high-pressure case opens, flow through the high-pressure case increases almost immediately. This loop's time constant is small because the volume between its antisurge valve and discharge is small. Because of the large inter-stage cooler there is a large volume in the low-pressure case's recycle line which may be further worsened by additional volume due to the potential need of a discharge knock out drum. The time constant of this section's antisurge control loop is much larger because of the inertial mass of the extra gas. This can lead to adverse control interaction.

Suppose the high-pressure case is moving towards its surge limit and starts to recycle to avoid surge. The discharge pressure in the low-pressure case will rise rapidly because the high-pressure recycle line feeds into the low-pressure case's discharge.

As this pressure rises, the first section's controller reaches its surge control line and opens its antisurge valve to lower the pressure. However, low-pressure section discharge pressure is dominated by high-pressure recycle and continues to

rise. When the low-pressure case starts to recycle, it immediately diverts flow from the suction of the high-pressure case. The high-pressure case must then increase its recycle to make up for the extracted flow, driving discharge pressure at the low-pressure case even higher. The net effect of low-pressure section recycle may be to increase in the first few seconds, rather than decrease the discharge pressure of that stage, thus possibly resulting in the section failing to avoid surge.

Adding a cooler to each recycle line is an ideal solution, but it is not the only solution. The system can be improved by changing the piping to include the upstream process cooler and an addition of a check valve between stages, as shown in Figure 28 below. This approach almost completely eliminates the problems inherent in the original layout shown in Figure 27.

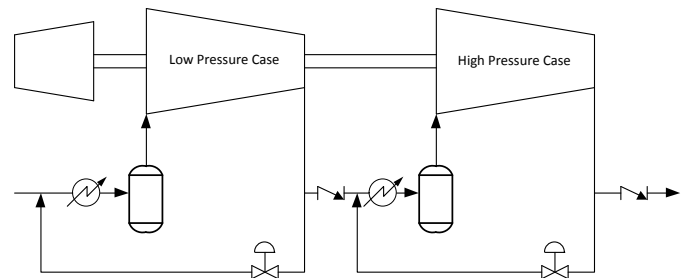

Figure 28. Improved piping design

The volumes between each compressor discharge and antisurge valve are small, so both antisurge controllers can be tuned aggressively. This keeps recycling to an energy-efficient minimum. Because the two loops have similar time constants, controller interactions are less dramatic and decoupling more effective.

Single overall recycle line across multiple stages

Figure 29 shows a two stage compressor with a single overall recycle path. Using a single recycle path is sometimes employed as the main method of avoiding interactions between individual antisurge control loops, as in Figure 28. This solution can result in excessive recycle and degrades surge protection. For example in Figure 29, the single recycle path may offer adequate protection for the high-pressure case, but it protects the low pressure case very poorly. The possible large time delay and lag before the discharge pressure of the low-pressure case decreases may present challenges when operating near its surge limit.

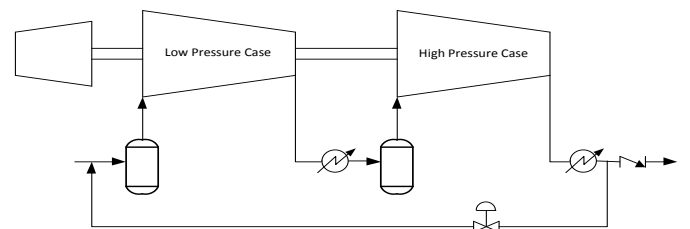

Figure 29. Two-stage compressor with one overall recycle path

Process applications that do not require recycling the gas such as process air compressors use blow off lines to provide antisurge protection. Process air compressors and air blowers which can have up to five or six stages can be effectively controlled utilizing a single blow off line located in the discharge, as shown in Figure 30. Additional blow off lines and valves may be required on these machines to accommodate substantial differences in surge flow on lower pressure stages.

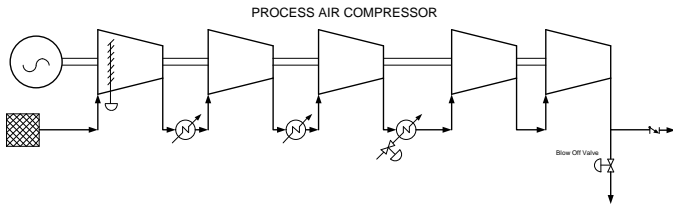

Figure 30. Typical Process Air Compressor

Multi-sectional compressors

Multi-sectional compressors with sidestreams, such as those used in refrigeration processes, differ from multi-case compressors in that all the compressor section recycle lines have the take-off from the discharge of the compressor. See Figure 31 below. This piping arrangement introduces time delays in the overall response of the system. Reduction in head across the compressor is less effective as a means of protecting the compressor from surge. Therefore increasing flow through each section becomes the primary means for surge prevention.

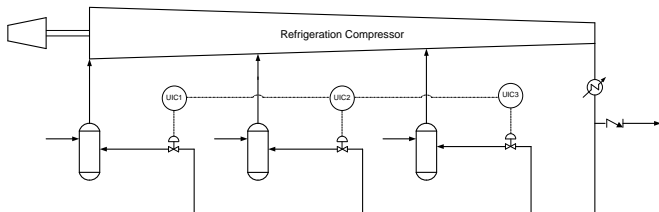

Figure 31. Typical three section side stream compressor

Although opening the first section's antisurge valve will benefit the following stages by increasing throughput, opening of downstream section's antisurge valve can have negative effects on upstream sections. For example, when the third section antisurge valve opens, the pressure in the second section discharge increases, as does the resistance. This tends to drive the second section towards surge. To overcome this and the lag times associated with longer recycle lines, loop decoupling, as described earlier, should be established between the downstream and upstream section antisurge controllers. For example in Figure 31, antisurge controller UIC1 should decouple from UIC2 and UIC3, while antisurge controller UIC2 should decouple from UIC3.

Multi-sectional compressors with side streams often utilize liquid quench to cool the recycle gas. Using liquid quench to cool the recycle gas, instead of discharge process coolers, helps reduce the large discharge volumes that are typically associated with refrigeration cycles. Also, quench

provides additional flow to the recycle path, which benefits the antisurge control system. Quench lines need to be tied in downstream of the antisurge valves and upstream of the inlet separation drums, as shown in Figure 32.

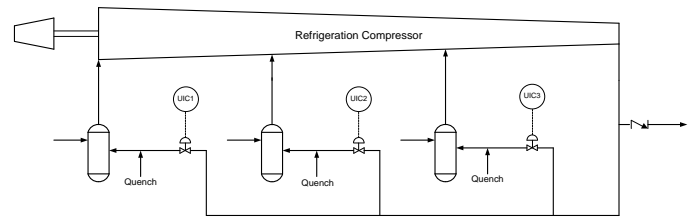

Figure 32. Typical three section side stream compressor

Parallel compressor systems

Piping designs for parallel compressor systems, as illustrated in Figure 33, need to account for isolation of the individual compressor trains to allow for standalone operation, as well as successful startup and shutdown of each parallel compressor train.

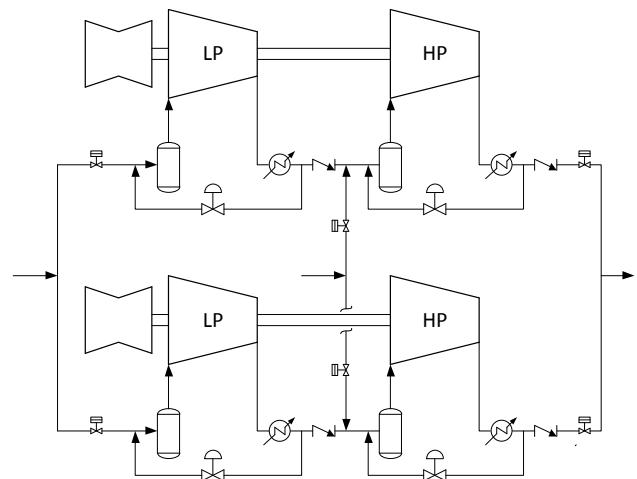

Figure 33. Typical piping layout for parallel gas lift compressors

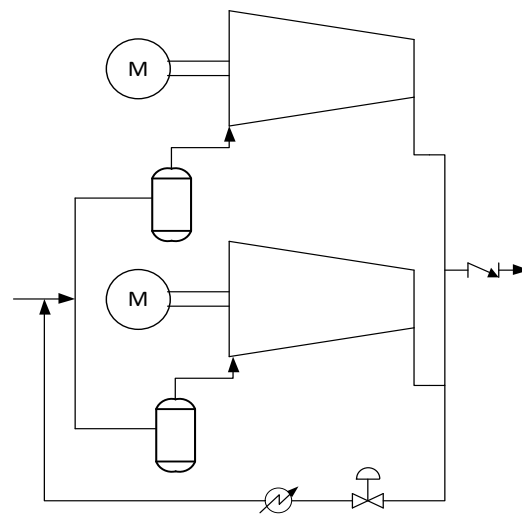

Figure 34. Shared Recycle Path

Block valves are used to isolate an offline compressor while discharge check valves are used to bring the compressor offline as well as online.

Compressors operating in parallel with common suction and discharge headers need to have individual recycle paths. A shared recycle path, as shown in Figure 34, will reduce the effectiveness of the antisurge control system during normal operation, but the bigger problem for this layout is starting and stopping one of the machines.

When one compressor is running and a second compressor needs to be started, the second compressor will most certainly surge, due to the running compressor taking all of the recycled flow of the starting compressor until the starting compressor will come on line. Even worse situation will exist when one unit is taken off line.

The above situation illustrates well how the same problem exaggerates further with closed loop parallel compressor systems, such as refrigeration cycles. These systems require separate suction drums in order to operate in parallel safely. Figure 35 illustrates an incorrect piping layout that is designed with common suction drums between two parallel refrigeration compressors.

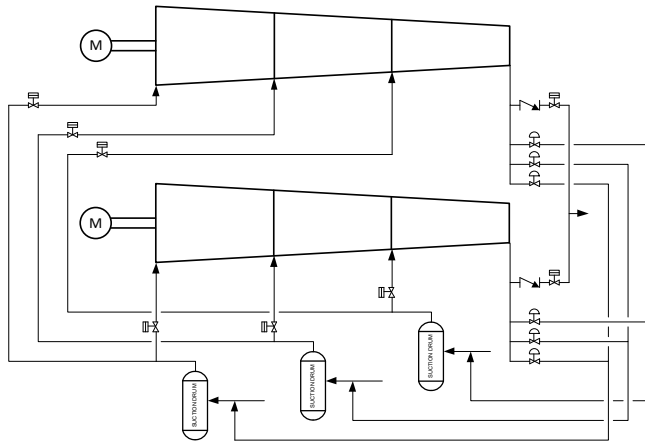

Figure 35. Incorrect piping design utilizing common suction drums

With this piping configuration, the effectiveness of the antisurge control system is reduced while both compressors are in operation. This is due to having part of the flow through an opening antisurge valve absorbed by the other compressor. In addition, a compressor that is being brought online or offline while the other is in operation has a high potential of surging since the running compressor will take the majority of the flow. Having separate suction drums for each compressor allows each compressor to run independently and eliminates the above potential risks associated with common suction drums.

ANTISURGE VALVE SELECTION

An antisurge valve must achieve the following requirements:

- The antisurge valve must be correctly sized in order to:
 - Provide adequate antisurge protection during the worst possible surge-inducing upset; in any operating regime within operating envelope of the compressor as depicted in the compressor map (this excludes protection of the compressor from the start/stop modes, and emergency shutdown especially, that should be reviewed in addition to the below methodology);
 - Provide adequate recycle/blow-off to satisfy any configured process limiting response; and
 - Provide flow peaks greater than what is required to achieve steady-state operation on the surge control line;
- Furthermore, the antisurge valve must not be oversized such that:
 - When fully open, it drives the compressor into its choke region; or
 - It introduces controllability issues.
- The Antisurge Valve also must meet following dynamic and accuracy requirements:
 - Full stroking time to open, under positioner control, of less than 2 seconds with less than 0.4 seconds of time delay without significant overshoot and closing time, also under positioner control, of no more than 8-10 seconds
 - Linear (Preferred) or equal percentage characteristic of the valve
 - Positioning accuracy 1 percent or better

Heuristic Approach to Antisurge Valve Sizing

Imagine a simple single stage compressor (equipped with an antisurge valve) that is forced to operate in full recycle, as illustrated in Figure 36, below:

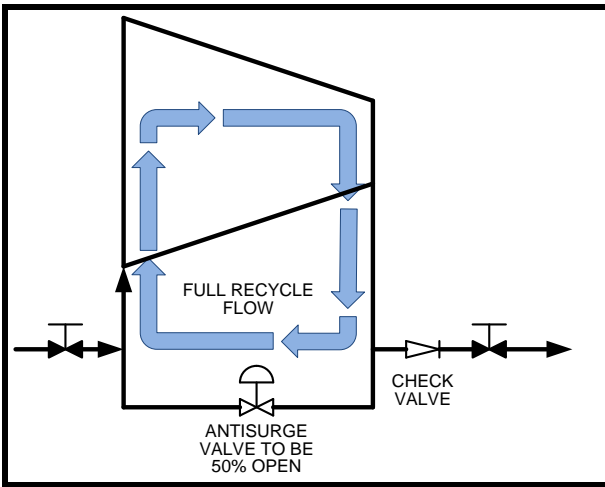

Figure 36. Single Stage Compressor Operating in Full Recycle

In our many years of experience, the criteria listed above is met if the antisurge valve that is open approximately 50 percent will drive the compressor into surge, while the compressor (stage) under protection is operating in full recycle.

This provides a heuristic approach to sizing the antisurge valve, namely it should be sized approximately for twice the steady-state surge flow. Using a reasonable ± 10 percent tolerance produces the following guide-line: The antisurge valve should be sized for 1.8 – 2.2 times the surge flow.

Validation of the Heuristic Approach to Antisurge Valve Sizing

As a simplified example to illustrate the heuristic approach to proper antisurge valve sizing, we review a variable speed, or variable IGV, compressor that may have following performance map, as developed by the compressor OEM:

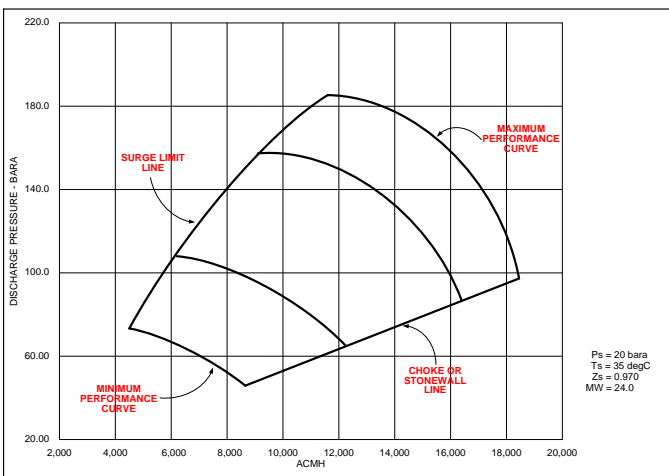

Figure 37. Performance Map of a Variable Speed (or IGV) Compressor

If the performance map of Figure 37 above, describes the compressor (as illustrated in the previous Figure 36), then it

is possible to “super-impose” lines of antisurge valve capacity, Cv onto it, yielding the following combined performance map (Figure 38):

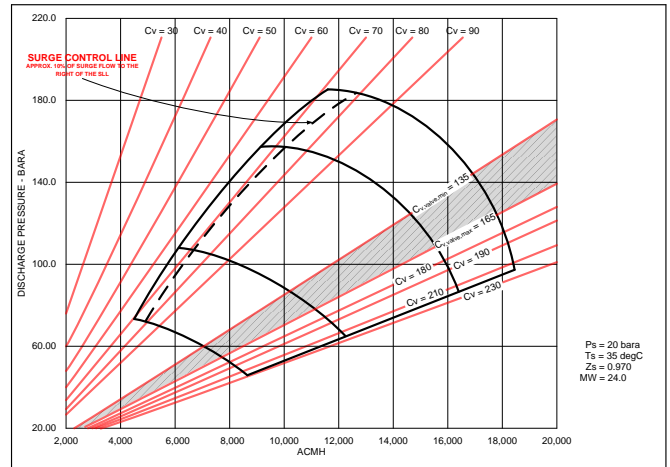

Figure 38. Antisurge Valve Cv curves superimposed onto the Compressor Performance Map

As seen in Figure 38, an antisurge valve with a Cv value of approximately 75 would provide the minimum steady-state antisurge flow to keep the compressor in full recycle. Thus, according to the “1.8 – 2.2 times the surge flow” guideline, a valve with a full-stroke Cv value of between 135 and 165 should be used for antisurge duty for this compressor.

With the compressor operating in a full recycle mode, such a valve, even when fully opened, would not have the capacity to drive the compressor into its choke region (that would occur for a Cv > 220).

ISA Valve Sizing Equation

The ISA valve sizing equation (ISA-S75.01-1985) based on mass flow through the valve is used. This equation is:

$$Cv = \frac{W_s}{N_s \cdot F_p \cdot P_1 \cdot Y} \cdot \sqrt{\frac{T_1 \cdot Z_1}{X \cdot MW}} \quad (33)$$

Deriving the Mass Flow (Ws) through the Antisurge Valve

Applications Where the Antisurge Line Spans A Single Compressor Section

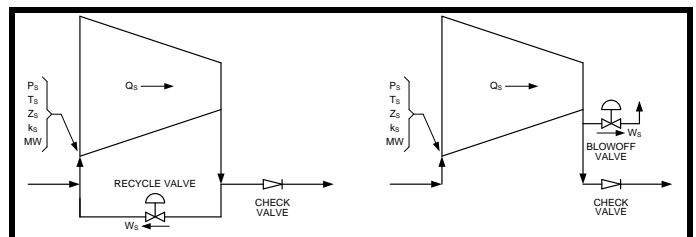

Figure 39. Antisurge Line Spans A Single Compressor Section

Imagine the compressor as operating in full recycle (left pane of above Figure 39), or full blow-off (right pane of above).

The volumetric flow rate at the Surge Point Q_{SLL} is determined from the supplied compressor performance curves. The equivalent mass flow rate (W_{SLL}) is then calculated and this is used for antisurge valve sizing purposes.

$$W_{SLL} = Q_{SLL} \cdot \rho_s \quad (34)$$

where:

$$\rho_s = \frac{P_S * MW}{Z_S * R_O * T_S} \quad (35)$$

Applications with Side stream Compressors

Side stream compressors present more challenge to the previous approach of using the surge flow at the maximum performance curve, as previously described. This is because each stage's performance curve is given for conditions at the common RATED speed for all the stages. A slightly different, but fundamentally similar approach is used. The first step, the same as in the example above is to establish steady-state mass flow rates for all stages of the compression that are then increased by using the same heuristic method as above.

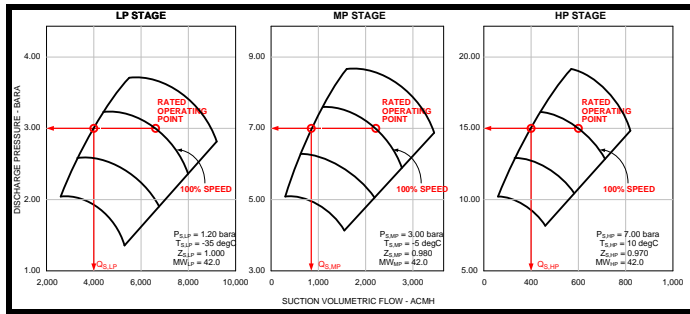

Figure 40. Compressor Maps for a 3-Stage Side stream Compressor

As may be seen in Figure 40, a horizontal line is drawn that passes through each stage's rated point. Where this horizontal line intersects with the surge limit line, the suction volumetric flow (Q_{SLL}) is noted.

Next, it is imagined that the compressor operates in full recycle, as per the following Figure 41:

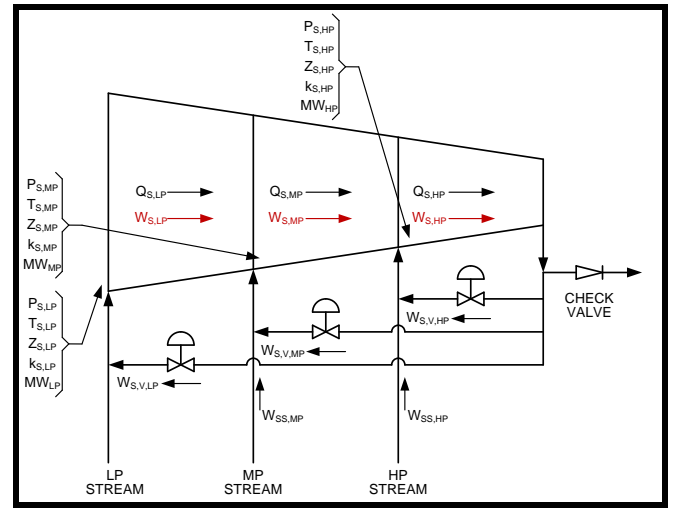

Figure 41. 3-Stage Side stream Compressor in Full Recycle

For the LP stage, determining the mass flow for the LP antisurge valve calculations is straightforward. It will be the mass flow that corresponds to the LP stage surge Limit Line volumetric flow, as derived above, and where density $\rho_{s,LP}$ is calculated as per equation (35) above:

$$W_{SLL,LP} = Q_{SLL,LP} \cdot \rho_{s,LP} \quad (36)$$

For the MP stage, we first determine the surge limit line mass flow from the MP stage surge limit line volumetric flow using density $\rho_{s,MP}$, as derived above:

$$W_{SLL,MP} = Q_{SLL,MP} \cdot \rho_{s,MP} \quad (37)$$

In the assumed steady-state full recycle situation, the MP stage thus requires a steady-state mass flow rate equivalent to the above-derived $W_{SLL,MP}$. But the MP stage is already receiving a mass flow equivalent to $W_{SLL,LP}$, coming from the LP stage (which may be considered as credit), and so, the MP antisurge valve needs to supply only an additional steady-state mass flow amount $W_{V,MP}$ equal to:

$$W_{V,MP} = W_{SLL,MP} - W_{SLL,LP} \quad (38)$$

For the HP stage, a similar approach is adopted: We first determine the Surge Limit Line mass flow from the HP stage Surge Limit Line volumetric flow, as derived above:

$$W_{SLL,HP} = Q_{SLL,HP} \cdot \rho_{s,HP} \quad (39)$$

In the assumed steady-state full recycle situation, the HP stage thus requires a steady-state mass flow rate equivalent to the above-derived $W_{SLL,HP}$. But the HP stage is already receiving a mass flow equivalent to $W_{SLL,MP}$, coming from the MP stage (which may be considered as credit), and so, the HP antisurge valve needs to supply only a steady-state mass flow amount $W_{V,HP}$ equal to:

$$W_{V,HP} = W_{SLL,HP} - W_{SLL,MP} \quad (40)$$

Deriving the Antisurge Valve Inlet Pressure P_1 and Outlet Pressure P_2

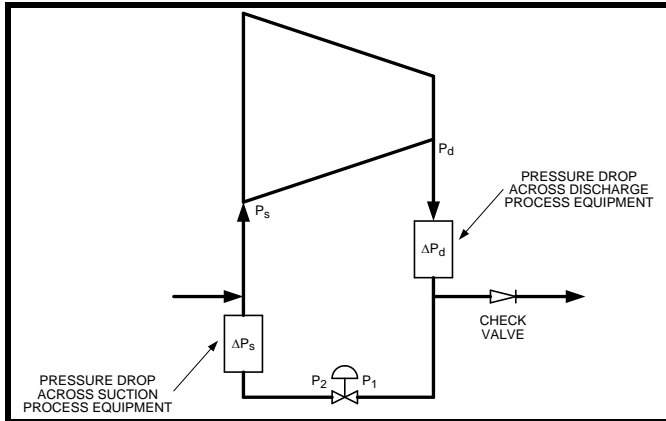

Figure 42. Deriving the Antisurge Valve Inlet (P_1) and Outlet (P_2) Pressures

As may be seen from Figure 42 above, the antisurge valve inlet pressure value P_1 , for antisurge valve sizing calculation purposes, should be determined by accounting for all the pressure losses ΔP_d between the compressor stage discharge flange and the antisurge valve inlet:

$$P_1 = P_d - \Delta P_d \quad (41)$$

Likewise, the antisurge valve outlet pressure value P_2 , for antisurge valve sizing calculation purposes, should be determined by accounting for all the pressure losses ΔP_s between the compressor stage inlet flange and the antisurge valve outlet:

$$P_2 = P_s + \Delta P_s \quad (42)$$

Deriving the Antisurge Valve Inlet Temperature T_1

In most applications, the antisurge valve is located downstream of an aftercooler, so that the piping configuration looks like the following Figure 43:

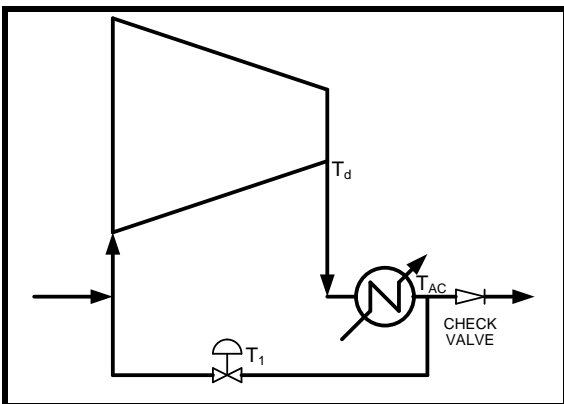

Figure 43. Deriving the Antisurge Valve Inlet Temperature (T_1) – Case 1

In this case, the antisurge valve inlet temperature T_1 may be assumed as being equal to the aftercooler design outlet temperature.

$$T_1 = T_{AC} \quad (43)$$

In some cases, the antisurge valve is located upstream of any aftercoolers, i.e. the piping configuration looks like the following Figure 44:

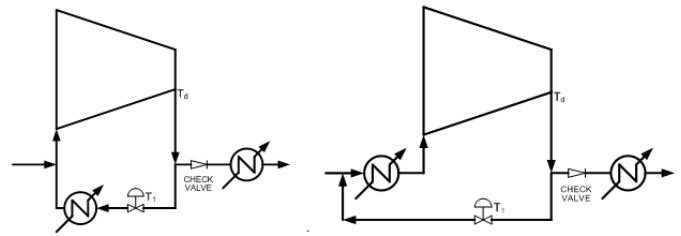

Figure 44. Deriving the Antisurge Valve Inlet Temperature (T_1) – Case 2

In such applications there is usually some method to cool the recycle flow, such as a recycle cooler (as illustrated in the left pane of above Figure 44), or a process cooler (as illustrated in the right pane of above Figure 44).

In cases such as these, for antisurge valve sizing calculation purposes, the antisurge valve inlet temperature value T_1 may be determined assuming it is equal to the compressor outlet flange discharge temperature.

$$T_1 = T_d \quad (44)$$

Deriving Gas Compressibility Factor Z_1 at the Antisurge Valve Inlet

While the actual value of the gas compressibility factor at the antisurge valve inlet will depend on the pressure and temperature at various points of the supplied compressor performance maps, we are assuming the value given on the compressor data sheets at the discharge flange at design conditions produces the usual acceptably accurate capacity calculations. Therefore:

$$Z_1 = Z_{d,design} \quad (45)$$

Alternatively one of available Gas Equations of State (EOS) can be used to establish a more accurate value of Z_1 .

Deriving the Gas Expansion Factor (Y) For Antisurge Valve Calculations

According the ISA, the following equation produces the value of the gas expansion factor (Y) at the antisurge valve inlet:

$$Y = 1 - \frac{X}{3 \cdot F_K \cdot X_T} \quad (46)$$

The value of Y is limited at the upper end to 1.0000 and at the lower end to 0.6667.

Also note that If $X > (F_K \cdot X_T)$, then $(F_K \cdot X_T)$ should be used in place of X in the equations for Y and C_V .

Deriving the Piping Geometry Factor (F_p) For Antisurge Valve Calculations

According the ISA, the piping geometry factor F_p is calculated as:

$$F_p = \left[1 + \frac{\Sigma K}{890} \cdot \left(\frac{C_{V,V}}{d_1^2} \right)^2 \right]^{-\frac{1}{2}} \quad (47)$$

Where:

$$\Sigma K = K_1 + K_2 + K_{B1} - K_{B2} \quad (48)$$

$$K_1 = 0.5 \cdot \left(1 - \frac{d_1^2}{D_1^2} \right)^2 \quad (49)$$

$$K_2 = 1.0 \cdot \left(1 - \frac{d_2^2}{D_2^2} \right)^2 \quad (50)$$

$$K_{B1} = 1 - \left(\frac{d_1}{D_1} \right)^4 \quad (51)$$

$$K_{B2} = 1 - \left(\frac{d_2}{D_2} \right)^4 \quad (52)$$

Where:

ΣK is a factor that accounts for the effective velocity head coefficients of the fittings attached to but not including the valve

Antisurge Valve Sizing and Compressor Choke

For single speed compressor maps, only the two end points of the compressor curve need to be considered: the surge point (A) and the choke point (C), as shown in Figure 45.

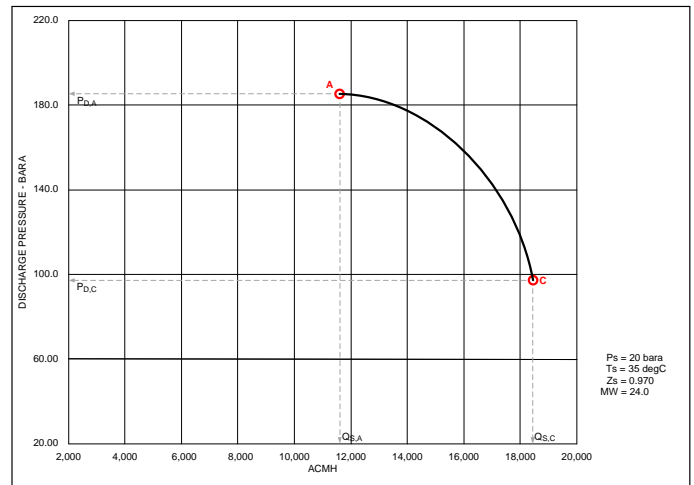

Figure 45. Single Speed Compressor Maps: Only Two Antisurge Valve Sizing Points needed

As shown in Figure 46 for variable speed compressor maps, and in order to properly position the quadrants of the compressor performance map onto the space of the various antisurge valve C_V curves, a minimum of four points of the compressor performance map need to be considered:

- The intersection of the maximum performance curve and the surge limit line – point A
- The intersection of the minimum performance curve and the surge limit line – point B
- The choke point of the maximum performance curve – point C
- The choke point of the minimum performance curve – point D

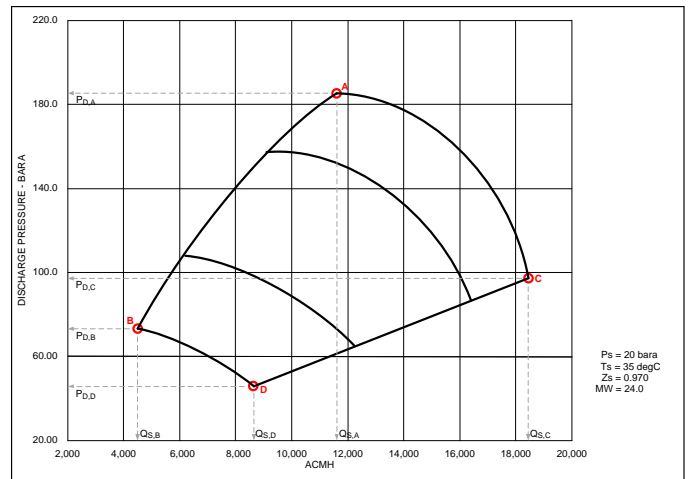

Figure 46. Variable Speed or IGV Compressor Maps: The Four Antisurge Valve Sizing Points

In the majority of applications, it is expected that the calculated antisurge valve C_V values for the above two surge points A & B will be close to each other, and the same applies for the calculated C_V values for the above two choke points C & D. In order to be conservative, the higher of the two values A & B (to be considered as the Surge Line C_V or $C_{V,SLL}$), and

the smaller of the two values C & D (to be considered as the Choke Line C_v or $C_{v,choke}$) should be chosen to determine the suitable antisurge valve sizing.

Dynamic Characteristics of the Antisurge Valve

The antisurge valve must stroke quickly and precisely in response to complex command signal profiles generated by an antisurge controller. Typically the antisurge controller output, combines slower responses with open-loop step changes, followed by a decaying profile that is configured by the antisurge controller.

The actuation system of the antisurge control valve must be engineered to produce the required smooth and precise stroking of the valve that matches the command signal of the antisurge controller.

The antisurge control valve actuation system typically includes such components as:

- A digital positioner that provides for both slow and fast command signals of the antisurge controller.
- Devices that amplify action of the motive fluid of the actuator in both the opening and closing directions (e.g. volume boosters for pneumatic actuators), and,
- A quick-dump device (e.g. solenoid valve) that permits the quick opening of the antisurge valve in response to an ESD (emergency shutdown) signal that may be generated outside of the antisurge controller.

Examples of such complex command signals from the antisurge controller are:

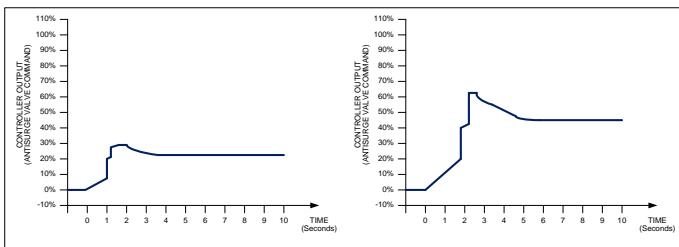

Figure 47. Examples of Complex Antisurge Controller Output (Valve Position Command) Signals

In order to assist the antisurge valve manufacturer to meet the performance goals for the antisurge valves, the following dynamic characteristics for the valve actuation should be achieved:

- **Fast and precise full-stroking of the valve under positioner control:**

Under positioner control, the valve must stroke from fully closed to at least 95 percent open in 2 seconds or less. Similarly, the valve must also stroke from fully open to at least 95 percent closed in approximately the same time (2

seconds or less), but in a maximum of 8-10 seconds or less. Significantly different stroking speeds in opposite directions will present unequal dynamic gains in the final control element that could compromise antisurge controller tuning.

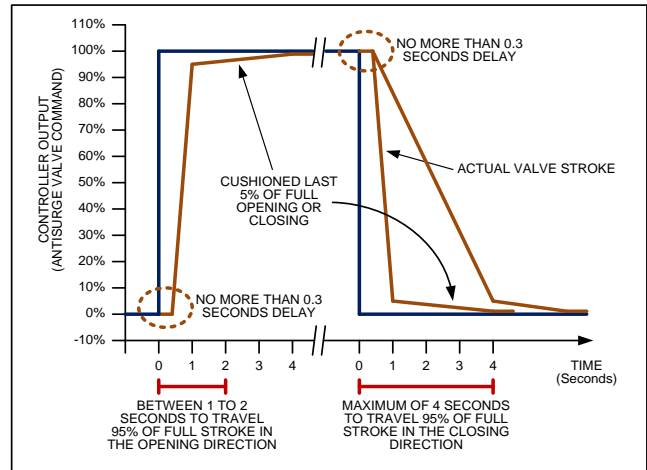

Figure 48. Full-Stroke Speed of The Antisurge Valve Under Positioner Control

To be noted, the above difference in opening and closing times is not specified for the purposes of the antisurge control, but should be allowed to enable valve OEM to deliver the specified valve quality. The antisurge controller must allow for the slow closing of the antisurge valve following an open-loop step opening of the valve, but it is recommended that this be achieved electronically within the controller by means of dedicated algorithms that set the controller output signal value (controlled decay), rather than different stroking speeds (depending on the direction of travel) within the antisurge valve actuation system.

When the antisurge controller commands the valve to fully open or close, the valve actuation system must exhibit no more than a 0.4 second delay time.

Finally, it is recommended that a “cushioning” feature be implemented in the actuation system (typically in the last 5 percent of full-stroke) to prevent the actuator from “slamming” against the mechanical stops at the end of stroke, which could potentially damage the actuator or the valve.

- **No significant hysteresis or overshoot of the valve for partial stroking under positioner control:**

The valve must partially stroke for fast or slow command signals from the antisurge controller without significant overshoot in either direction, and with a minimum of hysteresis when the command signal changes direction.

Since the antisurge controller may send the antisurge valve a command to step open and then resume

modulating control action, it is desirable to have the valve actuation system achieve the step change (in the opening direction) with as little instability as possible. Some “overshoot” (antisurge valve actuation system initially opens the valve more than the target position then settles to the target position) may be acceptable, continuous oscillatory behavior in valve actuation that may cause an overshoot in close direction is not acceptable.

In general, it is recommended that one-sided “overshoot” (i.e. in the opening direction only) should not exceed 10-15 percent of the step change in the controller output.

It is recommended to subject the antisurge valve with its actuation system to a controlled performance test at an internal valve static pressure and flowing conditions approximating actual process conditions to record the overshoot for step changes of 10, 20 and 50 percent, as shown in Figure 49.

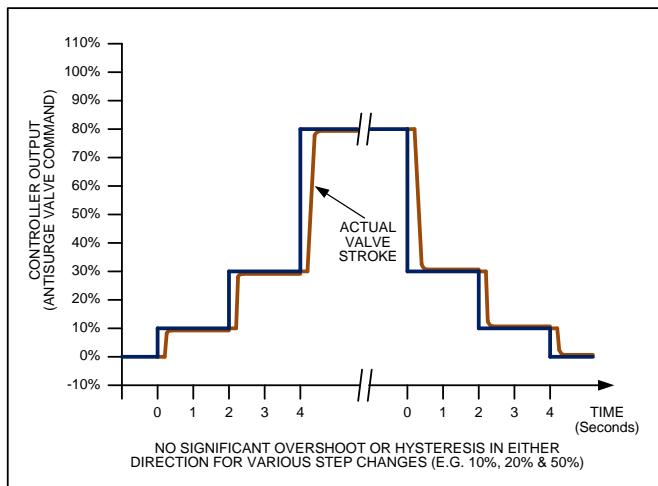

Figure 49. Partial-Stroke Testing of The Antisurge Valve Under Positioner Control

It is also recommended to test the valve by imposing a continuously increasing and then, decreasing signal and observe, record the result. The purpose of this test is to verify accuracy of calibration of the valve span, accuracy of positioning and to confirm that the response of the valve is smooth without jamming, hysteresis and slip-stick pattern in the response of the valve to continuous signals.

ANTISURGE CONTROL SYSTEM INSTRUMENTATION

In order to protect the compressor from surge, the control system must be able to accurately determine the proximity to surge in real time. The primary process measurements necessary for determining the proximity to surge are flow rate, suction pressure and discharge pressure. Differential pressure flow meters should be used for flow rate

measurement. Suction and discharge temperature measurement are necessary for systems that have varying gas composition or have the flow measurement located in the discharge of the compressor. For compressors that incorporate inlet guide vanes for process control, guide vane position measurement is necessary to account for the changes in machine geometry. Power or torque measurements are sometimes used for this purpose.

In addition to measurements used for determining the proximity to surge, other measurements are necessary in order to perform diagnostics of critical events, such as compressor trip or surge events, as well as analyzing the overall performance of the control system. It is highly desirable that speed measurement and antisurge valve position feedback to be available for high speed trending and recording of the antisurge control system operation.

Flow meter selection

The main criteria for flow measurement in antisurge control systems are speed of response, repeatability and an adequate signal-to-noise ratio.

The speed of response requirement is based on available industrial grade differential pressure flow transmitters which should have response times between 100 to 150 msec and not exceed 200 msec. The same speed requirement practically eliminates consideration for the antisurge control system for most any other available types of flow measurements, such as vortex shedding meters, ultra sound meters, etc.

Antisurge control systems are typically designed to operate with control margins of about 10 percent of surge line flow. The most challenging part of this requirement is to be able to provide for reliable measurement at the lower end of the compressor systems operating flow range, assuming that the transmitter and the flow measuring device itself are spanned properly to insure that the upper end is measured accurately, too. As a general guideline, the type and location of the flow-measuring device should be such that the pressure differential corresponding to the maximum flow through the compressor is 10 inWC (2.5 kPa) or more. If it is less, the noise level of the flow-measuring device may most likely be comparable with its signal. This is particularly true when the operating point is located on the surge control line and the pressure differential is less than 50 percent of the maximum. If the flow-measuring device is noisy, it is necessary to dampen its signal. However, this slows down the dynamic capability of the antisurge control system and reduces its effectiveness and may result in a larger than normally expected antisurge control margin.

The type of flow meter selected will depend on several factors such as pipe size, available piping length straight run, allowable permanent pressure loss, type of process gas, and overall cost. Overall cost consideration should include initial costs, installation costs and operational costs. The below table lists some flow measurement devices used for antisurge control

systems (Brun and Nored, 2008).

Table 1. Flow Measurement Types Used for Antisurge Control Systems

Type	Advantages	Disadvantages
Orifice Plates	Reliability Less initial costs	High permanent head loss Long straight-pipe run requirements Prone to installation errors
Venturi	Reliability and accuracy Low permanent head loss Requirement for straight pipe run is less than orifice plates	Higher initial costs Long straight-pipe run requirements
Flow Nozzles	Good accuracy Lower initial costs	Higher permanent head loss than Venturi
Pitot Tube of various types	Low permanent head loss Low cost	Intrusive device Reliability Produces very low differential pressures Often produces unacceptably low dP signal
Suction Eye	Low cost	Reliability and accuracy affected by installation Non-linear flow-dP relationship Often no good available calibration curve
V-Cone	Short straight-pipe run requirements Good accuracy and repeatability	Insertion device in pipe Higher initial costs

Flow meter location

When determining the location of the flow meter, the required upstream and downstream piping lengths must be considered and rigorously followed. Each type of flow meter will have specific requirements and if these requirements are not followed, the resulting accuracy, linearity and noise characteristics of the flow measuring device may become unpredictable. As a result, improper installation will directly affect the antisurge control system.

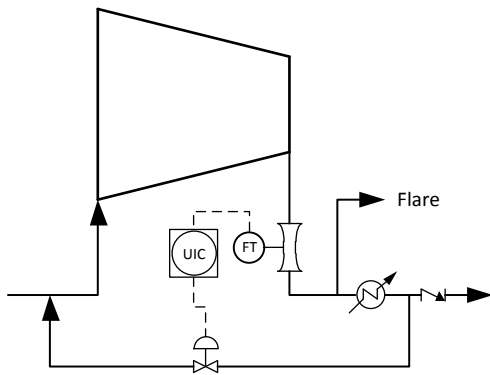

Figure 50. Flow meter in discharge

Flow meters used for antisurge control need to measure the total throughput of the compressor while it is in operation. Incoming or outgoing piping streams such as flare lines or inter-stage headers should not be located between the installed flow meter and the compressor, as shown in Figure 50.

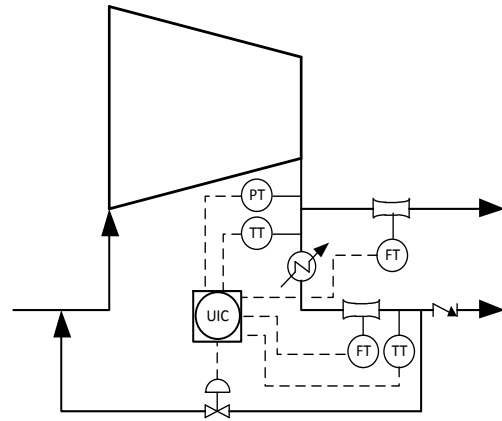

Figure 51. Additional flow measurement required

If direct flow measurement is not possible due to constraints of the system, additional flow measurement needs to be brought in to compensate for subtraction or addition of flow (see Figure 51). If the pressures and/or temperatures are different for each flow measurement device, then these will also need to be measured and brought into the antisurge control system in order to calculate and add the mass flow through each stream.

In applications such as refrigeration compressors, direct flow measurement through each compressor section is usually not possible. In this case, an acceptable alternative is to sum the flows of either the previous section or the succeeding section with the side stream flow (as shown in Figure 52 and in preceding chapters as explanation).

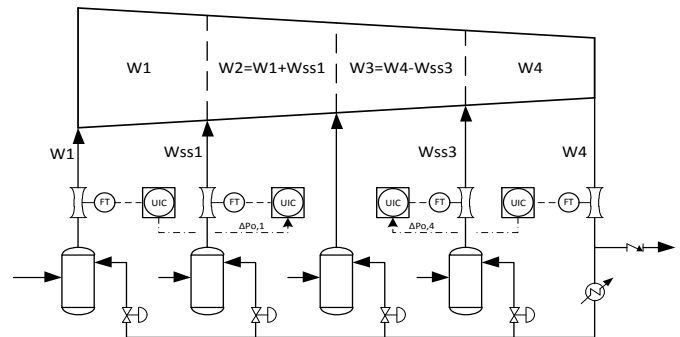

Figure 52. Refrigeration compressor with inlet side streams

This approach requires that the gas composition is the same for all the inlet streams into the compressor, as is the case of a closed loop refrigeration cycles. In order to reduce the errors associated with assumptions required to calculate the flows needed for operation of the antisurge control system, flow measurement devices should be installed in the suction and discharge of the compressor for direct measurement (Note, the example illustrated in Figure 52 shows flow measurements available on selected three inlet streams and also on the discharge stream. In reality, the needs of the antisurge control system may be satisfied by the availability of any four of the flow measuring devices).

Transmitter selection

Transmitters used for antisurge control must have a high reliability and high speed of response. A properly chosen range for a transmitter is important to the reliable operation of the control system. At the same time the transmitter range should be wide enough to accommodate the maximum control signal. It is recommended to span the transmitters so their minimum signal would not be less than 10 percent.

The response and effectiveness of the compressor control system is dependent also on the process information provided by the pressure transmitters. The controller must receive accurate, repeatable and timely process information in order to provide an adequate control response to an impending compressor upset or an impending compressor surge condition. The use of transmitters with a long response time and/or heavy signal dampening is certainly affecting negatively dynamic response of the antisurge control system and not recommended. See Figure 53 below.

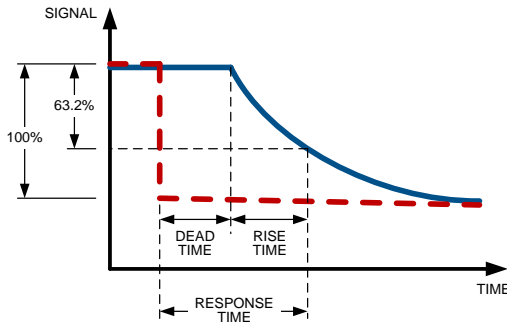

Figure 53. Transmitter Response Time

Differential pressure (flow) transmitter response times should be around 100 to 150 msec and not more than 200 msec. Pressure transmitters are less critical and response times of 300-400 msec is acceptable.

Signal dampening is used to reduce signal noise which might otherwise lead to improper action of the antisurge controller. However, heavy signal dampening will increase the rise time and may smooth out the transmitter output signal to such a degree that some of the compressor dynamics are not reported by the transmitter's output signal.

A stepped output, which is characteristic of some "smart" digital transmitters, can reduce the usefulness of the controller's derivative-response based functions.

Location of Instrumentation

All antisurge control system transmitter taps should be located as close as possible and as acceptable by Instrumentation norms to the compressor, as shown in Figure 54. This recommendation includes temperature sensors. Locating the points of process sensing as close to the compressor as possible provides the quickest and most accurate information about process conditions around the compressor.

When selecting the location for the transmitter,

vibration at the point of installation must also be considered. Installation on or near rotating machinery, or on a segment of pipe affected by vibration may produce adverse effects on the transmitter and its signal.

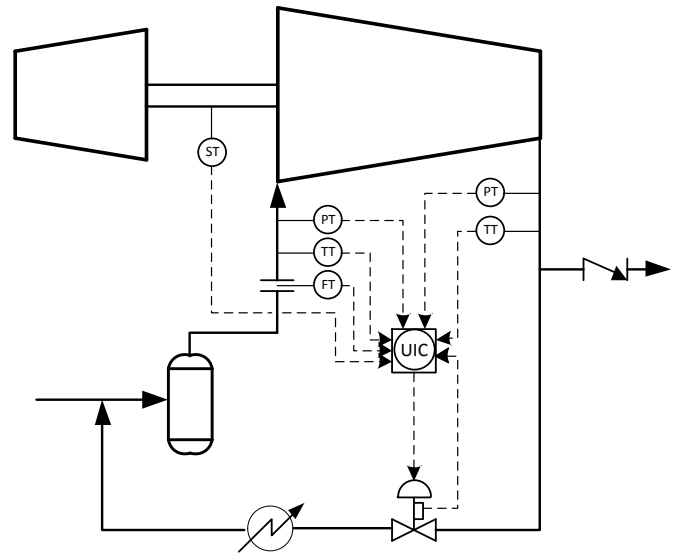

Figure 54. Transmitter tap locations

Process signal compensation

In some cases it may be necessary to compensate for pressure and temperature differences due to process valves, coolers, vessels or other restrictions in the process piping surrounding a compressor. Figure 55 shows an example of having a suction throttle valve installed between flow measuring device and the compressor inlet, with the pressure measurement between the suction throttle valve and the compressor inlet. Figure 56 shows the same suction throttle valve installed between flow measuring device and the compressor inlet but with the pressure measurement upstream of the suction throttle valve.

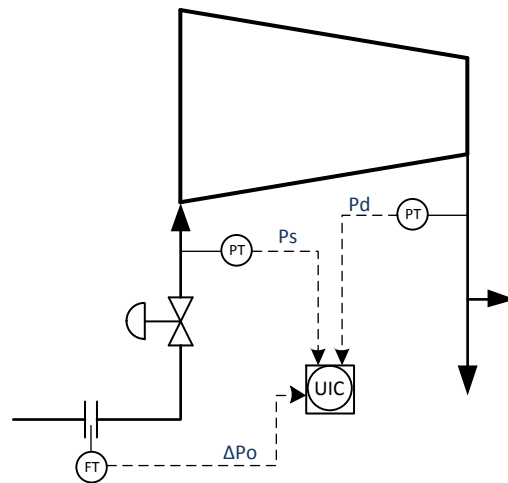

Figure 55. Incorrect reduced flow calculation

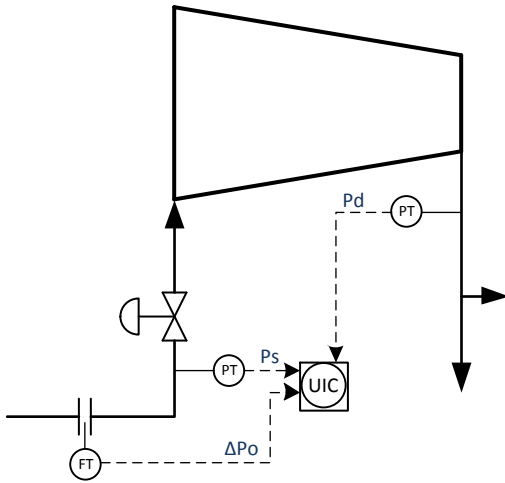

Figure 56. Incorrect reduced head calculation

In Figure 55, the antisurge control system will correctly calculate the reduced head (P_d/P_s) across the compressor, however it will incorrectly calculate the reduced flow ($\Delta P_o/P_s$). In Figure 56, the antisurge control system will correctly calculate the reduced flow, however it will incorrectly calculate the reduced head. In the first case, the calculated reduced head will be less than the actual since pressure upstream of the valve will be greater than the pressure at the compressor inlet due to the pressure drop across the valve. In the second case, calculated reduce flow will be greater than the actual since the pressure at the flow measurement device will be greater than the measured pressure downstream of the valve.

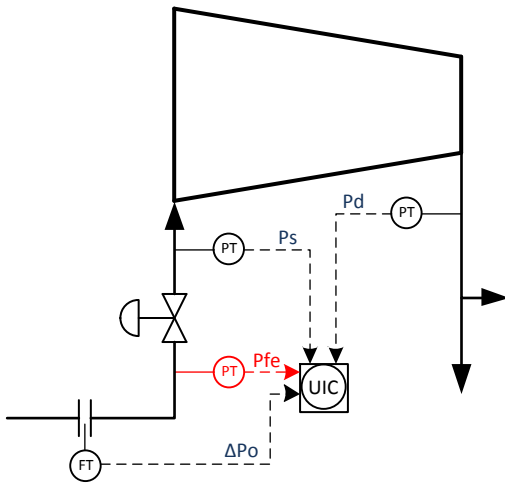

Figure 57. Required instrumentation locations

By installing an additional transmitter, as shown in Figure 57, the antisurge control system can compensate for the pressure drop across the suction throttle valve by calculating reduce flow as $\Delta P_o \cdot P_{fe}/P_s$ while reduced head is calculated as P_d/P_s . The same design considerations need to be applied to permanent suction strainers as well since the pressure drop across strainers can vary.

If the flow measuring device is located downstream of discharge cooler, as shown in Figure 58, temperature measurement is required downstream of the cooler in order to

compensate the flow measurement to compressor suction conditions.

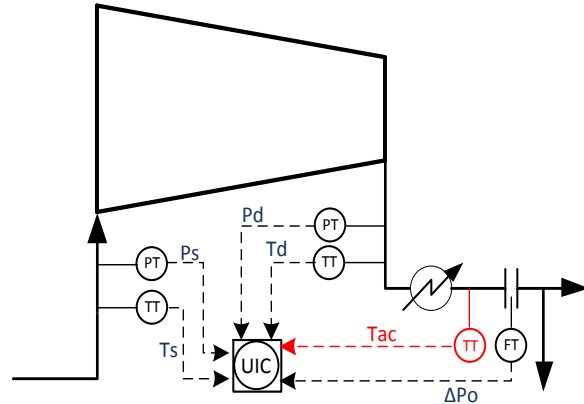

Figure 58. Required temperature compensation

Reduced flow in suction is then calculated as:

$$q_{sr}^2 = \frac{\Delta P_o}{P_s} \cdot \frac{T_s \cdot P_d}{P_s \cdot T_{ac}} \quad (53)$$

Reduced head is calculated as:

$$h_{pr} = \frac{K_c - 1}{\sigma} \quad \text{where } \sigma = \frac{\log(T_d/T_s)}{\log(P_d/P_s)} \quad (54)$$

Designing for transmitter installation

Poor pressure, and especially differential pressure, transmitter installation practices can greatly affect the performance of an antisurge control system. The transmitter should be mounted above its impulse tubing taps. The impulse tubing should be routed in such a way to avoid pockets. The impulse tubing should drain from the transmitter into the pipe. Mounting transmitters in this fashion will ensure proper performance and minimize transmitter troubleshooting time.

The location of the transmitter taps on the pipe is also an important consideration. The taps should be made on the upper half of the pipe. This tap location will reduce condensation buildup within the impulse tubing. Condensation buildup within the impulse tubing will adversely affect the correct reporting of the process conditions by the transmitter.

Transmitter access needs to be considered as well. In many cases transmitters are located at the nearest convenient access point which can lead to long impulse tubing lengths with several bends and horizontal runs. Long impulse tubing runs have a greater potential for vibration, accumulation of condensate and damage, and can slow down overall measurement response. Impulse tubing should be kept to a minimum such as 5 to 10 feet in length. In some cases this may require additional platforms for operator access to the transmitters.

CONCLUSIONS

Due to the limited volume of this Tutorial, only general coverage of the topic of interest had been addressed and much material remains beyond the scope of this paper. However this

Tutorial does provide general guidance and in the authors' view, satisfies the objective that real life systems must be designed with more attention to actual details of these very demanding control systems.

NOMENCLATURE

A = Flow coefficient of a flow measuring device
 ASV = Antisurge valve
 b1 = Surge margin, distance between SLL and SCL
 CR = Control response of the controller and its elements
 Cv = Valve flow capacity
 Cv,v = Cv value of the valve at full open
 D = Internal diameter of piping, (inch)
 DEV = Deviation of the operating point from the SCL, DEV=0 when the operating point is on the SCL
 d = Nominal inlet diameter of the valve, (inch)
 dPc = Pressure differential across compressor
 dPo = Pressure differential across flow measuring device (orifice typical), (inwc, or kpa)
 ΔP = (P1 - P2) pressure drop across the valve; alternatively, pressure drop across piping segment
 F_K = Ratio of the specific heat ratio of gas at the compressor discharge flange (at design conditions) to the specific heat ratio of air.
 Fp = Piping geometry factor
 f() = Characterizing function of variable under function
 FT = Flow transmitter
 H_p = Polytropic head (feet, or meter)
 h_{pr} = Reduced polytropic head
 K = Ratio of specific heats Cp and Cv of the gas
 MW = Molecular weight of the gas
 N8 = unit conversion factor (19.3 for English units or 0.948 for SI units)
 P = Pressure, (absolute)
 PT = Pressure transmitter
 Q = Volumetric flow rate, actual cubic feet per minute, (acfm, or m³/hr)
 q_{sr}² = Reduced flow squared
 R = Universal gas constant, 1545.3 ft *lbf/(lbmol.*°R) for English units, or 8.3143 J/(mol.*°K) for SI units)
 R_C = Compression Ratio across the compressor (or compressor stage)
 R_O = Universal gas constant
 S = Angular measure of distance between operating point and the SCL, S=1 for the SCL
 S_S = Angular measure of distance between operating point and the SLL, S_S=1 for the SLL
 SCL = Surge control line
 SLL = Surge limit line
 ST = Speed transmitter
 T = Temperature, (absolute)
 TT = Temperature transmitter
 UIC = Antisurge controller
 W = Mass flow
 X = Ratio of actual pressure drop across the valve to absolute valve inlet pressure
 X_T = Pressure drop ratio factor of the antisurge valve's particular internal geometry which is obtained from the valve manufacturer.

Y = Gas expansion factor
 Z = Compressibility
 ρ = Gas density
 η = Efficiency of the compressor (or compressor stage)
 σ = Polytropic exponent

Subscripts:

AC = Aftercooler
 av = Average
 d, D = Discharge
 fe = Flow element
 S = Suction
 SS = Side stream
 v = Valve
 LP = Low pressure stage of the compressor
 MP = Medium pressure stage of the compressor
 HP = High pressure stage of the compressor
 OL = Response of open loop control element
 PI = Response of PI control element
 1 = Valve inlet
 2 = Valve outlet

REFERENCES

- ASME PTC 10-1997, Reaffirmed 2003, "Performance Test Code on Compressors and Exhausters", American Society of Mechanical Engineers, New York, New York.
- Batson, B. W., 1996, "Invariant Coordinate Systems for Compressor Control", Proceeds of IGTA, Birmingham, UK.
- Bloch, H. P., 1996, "A Practical Guide to Compressor Technology", McGraw-Hill Companies.
- Boyce, M. P., 2003, "Centrifugal Compressors, A Basic Guide", PennWell Corp.
- Brun, K., Nored, M. G., 2008, "Application Guideline for Centrifugal Compressor Surge Control Systems", GMRC.
- Gresh, T.M., 2001, "Compressor Performance, Aerodynamics for the User", 2nd Edition, Butterworth-Heinemann.
- ANSI/ISA, 1985, "Flow Equations for Sizing Control Valves".
- Lapina, R. P., 1982, "Estimating Centrifugal Compressor Performance", Gulf Pub. Co.
- Ludtke, K. H., 2004, "Process Centrifugal Compressors", Springer-Verlag, Berlin.
- Staroselsky, N., Ladin, L., May 1979, "Improved Surge Control for Centrifugal Compressors", Chemical Engineering.
- White, M. H., December, 1972, "Surge Control for Centrifugal Compressors", Chemical Engineering.
- Wilson, J., Sheldon, A., August, 2006, "Matching Antisurge Control Valve Performance with Integrated Turbomachinery

Control Systems”, Hydrocarbon Processing.

ACKNOWLEDGEMENTS

The Authors of this paper would like to thank and acknowledge all of the Compressor Controls Corporation team members who provided valuable knowledge, materials and expertise in developing this paper.