



43rd Turbomachinery & 30th Pump Users Symposia (Pump & Turbo 2014)
September 23-25, 2014 | Houston, TX | pumpturbo.tamu.edu

OVERVIEW OF IMPORTANT CONSIDERATIONS IN WET GAS COMPRESSION TESTING AND ANALYSIS

Grant O. Musgrove

Research Engineer
 Southwest Research Institute
 San Antonio, TX, USA

Melissa A. Poerner

Senior Research Engineer
 Southwest Research Institute
 San Antonio, TX, USA

Massimiliano Cirri

GE Global Research –
 Europe
 Germany

Matteo Bertoneri

Conceptual Design Engineer
 GE Oil & Gas – Nuovo Pignone
 Florence, Italy



Grant O. Musgrove is a Research Engineer in the Machinery Program at Southwest Research Institute. He currently conducts applied research for turbomachinery applications in the Oil & Gas and power generation industries. His active research areas are wet gas compression, supercritical CO₂, and turbomachinery design. Mr. Musgrove's responsibilities range from technical analysis to project management for both experimental and computational activities. Mr. Musgrove graduated from Oklahoma State University in 2007 and from The Pennsylvania State University in 2009 with B.S. and M.S. degrees in Mechanical Engineering, respectively.



Melissa A. Poerner is a Senior Research Engineer and Test Program Coordinator in the Machinery Program at Southwest Research Institute. Her background includes work related to analysis and testing of compressors and other large machinery in adverse conditions such as wet gas or corrosive gas. In the past, she has been directly involved with design, operation, and project management of wet gas compression test programs. Ms. Poerner's work experience is supported by a Bachelor's of Science in Mechanical Engineering from Texas A&M University and a Master's of Science in Mechanical Engineering from Georgia Institute of Technology.



Matteo Bertoneri is a Conceptual Design Engineer within GE Oil & Gas, in Florence, Italy. His current duties involve research, development and prototype-testing activities on mechanical and thermodynamics conceptual design of new Centrifugal Compressors. His previous tasks were in Requisition office, designing

compressors for LNG and refinery jobs, and in Rotordynamic team, working on high speed rotor balancing. He has also worked as Test Engineer, responsible of Mechanical and Performance Tests of Centrifugal Compressors, Turboexpanders and Steam Turbines. Mr. Bertoneri received a B.S. and M.S. degree (Mechanical Engineering, 2010) from University of Pisa.

ABSTRACT

During upstream production of natural gas fields, it is common that a gas-liquid mixture of product is brought to the surface. The mixture, termed wet gas, is generally made up of mostly gas with a small amount of liquid, typically up to 5% by volume of the mixture. Because of the difficulties of compressing wet gas, the practical approach has been to separate the liquid and gas phases before compression. However, large separation equipment is unfavorable for subsea installations because of the cost to place machinery on the sea floor. Instead, a compressor designed for wet gas operation is preferred because it eliminates the need for large separation equipment leading to plant simplification and cost reduction. To address this design need, researchers have been active in addressing the challenges with wet gas compression. As result, experimental work has been conducted to study the effects of wet gas on compressor aerodynamic and mechanical performance. This experimental research has presented many challenges in recreating wet gas conditions and quantifying the effect of the liquid on the compressor performance. The results from this testing have helped to characterize the performance effects. But so far each work has focused on a range of test variables without identifying those that have the largest effect on compressor performance. This paper aims to provide the reader with an overview of the completed wet gas research, the challenges associated with doing the experimental work, and a discussion of the resulting trends observed in most of the wet gas research. This will include an in-depth review of relevant literature on wet gas compression testing and performance, a discussion of the important

research topics in wet gas compression, and a description on how wet gas experiments are set-up, performed, and the challenges associated with that testing. Also, this paper reviews the available test data using a multiple regression analysis to identify the important test variables and their effect on compressor power and pressure ratio. Some of the test parameters that are discussed are inlet pressure and temperature, gas-liquid temperature difference, liquid volume fraction, and speed. The results of the analysis are useful for establishing variables for a future test program to focus on operating conditions with the largest effect on performance. Additionally, the effects of wet gas on machinery performance are discussed relative to machine vibration and seals. Using the observed trends in test data and the knowledge from previous wet gas research, conclusions are presented to guide future analytical and experimental work in the area of wet gas compression.

INTRODUCTION

The flow stream from offshore upstream production of wellheads will often have a mixture of both gas and liquid with up to 5% liquid volume fraction. The liquid is often removed from the flow stream to avoid the negative influences of the liquid on the compression process. As production equipment is moved to the ocean floor, it becomes desirable to reduce the equipment footprint by eliminating the liquid separation equipment. Without liquid separation, however, the gas compressor must operate with two phase flow that can have significant effects on the compression process including both performance and reliability [1, 2, 3]. Therefore, it is important that compression systems be designed or modified to account for the liquid influences and maintain the same efficiency and reliability as in dry compression. To improve compressor designs, there have been several experimental and analytical research programs focused on understanding and improving wet gas compression. This paper aims to give the reader a comprehensive understanding of the state-of-the-art of wet gas compression, what is currently known about wet gas compression, the research being done to advance the technology, and the future planned research and trends for wet gas compression.

PAST AND CURRENT RESEARCH

Field Conditions

Before looking into the past and current research, it is important to have a clear picture of the expected operating conditions for a wet gas compression system. As is often the case, the research conditions are not actual conditions due to restrictions of time, money, and resources. The most well-known subsea compression applications are the Gullfaks, Ormen Lange, and Åsgard. A review of these production field conditions indicate that the typical compression system is as outlined below [4, 5, 6, 7, 8].

- **Suction Pressure:** ranges from 20 to 140 bara over lifetime of field
- **Compressor delta pressure:** 30 to 60 bara
- **Compressor flow rate:** 2 to 30 SMM³/day
- **Liquid Volume Fraction (LVF):** 0.25 to 5%
- **Compressor power rating:** 5 to 12.5 MW

As the gas field becomes depleted, the reservoir pressure and flow rate decrease. Therefore, the suction pressure at the compressor inlet reduces over time along with the compressor delta pressure and flow rate. The change in flow conditions directly affect the liquid volume fraction entering the compressor; whereby a maximum of 5% LVF is estimated as an upper limit for wet gas compression. Higher LVF than 5%, however, may be experienced in the field. Depending on the required flow rate and number of units at the field, compression power may vary from 5 to 12.5 MW. It is important to note that all three of these subsea compression projects are not currently operational in the field. The Gullfaks and Åsgard projects are planned for field installation in 2015 while the Ormen Lange in 2016 [9, 10, 11, 6]. All of these projects are currently working on research programs to understand how their compression systems will perform and how reliable they will be when they are installed. The past and current research to support the planned installations of subsea compression systems is discussed in more detail below.

Current Research

There have been concentrated efforts to understand wet gas compression from both theoretical and experimental perspectives. While wet gas research is ongoing, the analytical and experimental research that has been completed to date in the area of wet gas compression is discussed below

Experimental Research

The primary organizations that are currently involved in experimental wet gas research are the Norwegian University of Science and Technology (NTNU), Kårstø laboratory (K-lab), Framo Engineering, Dresser Rand (DR), General Electric (GE), and Southwest Research Institute (SwRI).

NTNU represents the academic research area in wet gas compression. NTNU has a single-stage centrifugal impeller test facility dedicated to wet gas compression research. The facility operates at ambient pressure and is used to measurement compressor performance and aerodynamic stability, and surge detection in wet gas compression. Much of this work is complimented with analytical research which will be discussed later [12, 13].

Also in Norway is the Kårstø laboratory which is commonly known as K-lab. K-lab is a metering and technology laboratory that is integrated with the Statoil Kårstø processing plant that serves gas and condensates from the Norwegian continental shelf. In recent years, K-lab has been used to test wet gas machinery at actual field operating conditions [14].

In 2008, a full scale wet gas compression test facility was constructed at K-lab, where two compressors from different vendors were tested. These compressors were subjected to flow streams up to 2-3% LVF with a mix of natural gas, water and condensate [15, 16, 17, 18]. In 2013 K-lab commissioned a facility to test compressors for wet gas applications while the compressors were submerged under water.

Statoil has partnered with Dresser-Rand in 2003 to complete testing of a single stage compressor under wet gas conditions at the Dresser-Rand laboratory. The single-stage testing was completed at suction pressures of 30 and 70 bara (which is representative of the actual conditions) and with a hydrocarbon/condensate mixture [3].

Framo Engineering, also based on Norway, is testing the compression system that is planned for installation in the Gullfaks field. Framo have built a loop to test an axial compressor in wet gas conditions, including submerged compressor tests. The testing at Framo Engineering includes evaluation of compressor performance, mechanical performance, and system endurance. Testing will be completed with an idealized fluid made up of nitrogen and Exxsol D80 and also a real fluid comprised of hydrocarbons [4].

General Electric (GE) has been heavily involved in evaluating and designing for wet gas compression. In 2008 they conducted performance testing of a single stage compressor at ambient pressures at their Munich Research Facility [19]. In 2010, they partnered with Southwest Research Institute® (SwRI®) and completed testing on a two stage compressor in wet gas conditions at an elevated suction pressure of 20 bara with air and water [1,2]. In 2013, they completed another set of tests with air and water at SwRI but with a single stage rotor. This testing also included more detailed aerodynamic measurements and a strong focus on rotordynamics as compared to the testing completed in 2010.

SwRI has been actively involved in wet gas compression research with General Electric in the past 4 years. In addition, SwRI has conducted independent research to quantify aerodynamic performance in wet gas conditions using a low-speed atmospheric wind tunnel. The advantage of the wind tunnel is that the flow is essentially isothermal and incompressible, resulting in test conditions that emphasize aerodynamic effects instead of the compressibility and thermal effects present in actual compressor testing. The results of this internal work are currently unpublished.

The general trends observed in the wet gas compression testing that has been documented in the public domain are listed below.

- The compressors dry performance does not significantly change after it has been subjected to wet conditions
- There is a significant power consumption increase when liquid is introduced into the flow stream
- The pressure ratio across the compressor generally increases when liquid is present
- The temperature ratio across the compressor decreases when liquid is present
- The volume flow rate through the compressor is reduced from the dry condition when liquid is in the flow stream
- Liquid droplet size or flow pattern has no effect on compressor performance when injected far enough upstream of the compressor to allow a natural two-phase flow regime to develop. Liquid droplet size or flow pattern has a noticeable effect on compressor performance when the liquid is injected at the compressor inlet guide vanes

There is a significant amount of analytical research that is being done in conjunction with the above experimental research. This research is described in more detail below.

Analytical Methods

The analytical methods that have been applied to wet gas

compression have typically been based on thermodynamic effects of the liquid phase on compressor performance. With the presence of liquid, the heat of compression is dissipated into the liquid which in turn evaporates throughout the compression process. Most of the open literature focuses on the thermodynamic effect of wet compression such that the aerodynamic effect is only accounted through the gas properties. Much of the work for predicting wet gas compression performance is founded in one-dimensional models of the compression path that are coupled to thermal models of liquid droplets that include evaporation. However, three-dimensional CFD methods have been utilized for axial compressor modeling. This section will provide a brief overview of the analytical models that have been applied for wet gas compression.

Direct Integration Approach

Characterizing the performance of wet gas compression is difficult when defining a polytropic efficiency using the widely-accepted equations from ASME PTC-10 [20]. The equations of PTC-10 are based on the method presented by Schultz [21] to characterize compressor polytropic performance using real gases instead of the ideal gas assumption. In the method, the inlet and exit conditions of the compressor are used along with gas properties taken at the average conditions between the inlet and exit. In wet gas compression, however, the compression process is expected to have a significant effect on the fluid properties due to phase change of the liquid. Therefore, a direct integration method has been used to quantify wet gas compression by iterating along incremental pressure steps through the compression process. In this method, the polytropic efficiency is estimated for the calculation and held constant for all iteration steps. From the method, the polytropic head and efficiency for the compressor are determined when the calculated discharge temperature matches the actual value. The direct-integration method has been shown by Huntington [22] to be more accurate than the Schultz method, and is compared among different equations of state by Hundseid [23]. A major advantage of the direct-integration method over the Schultz method is that the fluid properties are calculated for each step in the calculation instead of an average. Therefore, the method is better suited for high pressure ratio impellers or applications with significant property variation. The direct-integration method has been applied to wet gas compression data by Hundseid [24] to illustrate the large difference between the Schultz and direct-integration methods for wet gas compression. The drawback to the direct-integration method, however, is that both fluid phases are assumed to be in equilibrium. This leads to the fact that the prediction method is based on knowing the discharge temperature of the compressor, which is difficult to establish whether the measured value at the discharge flange is either the liquid or gas temperature. Nevertheless, the direct-integration method provides a promising approach to characterizing wet gas performance

Evaporation Performance Models

To predict the effect of wet gas on compressor performance, the most popular approach in the literature is to couple a one-dimensional model of the gas compression path

to a thermal model of the liquid phase. The coupling of the two models is done through equations of enthalpy and entropy that include phase change of the liquid as the gas temperature and pressure changes. The liquid phase in the model is usually assumed to be uniformly distributed in the flow in the form of very small, spherical droplets. The liquid is treated as a discrete phase such that the presence of the liquid is assumed to not affect the gas flow and droplet-droplet interactions are neglected. When individual liquid droplets are not considered in the analysis, bulk treatment of the liquid phase change is handled by calculating vapor fraction and enthalpy of vaporization. Considering individual liquid droplets, however, the evaporation is calculated using an estimate of the heat transfer coefficient around the droplet that is calculated from a slip velocity.

The method with and without individual treatment of the droplets is explained well by Härtel and Pfeiffer [25] for an axial compressor who compare the droplet model to using an ideal model that does not account for droplet size. Between the droplet model and an ideal model, the droplet model includes droplet diameter effects of evaporation that can be important for predicting droplet penetration in multi-stage compressors. Their work showed that the ideal model was equivalent to the droplet model when using 1micron droplet sizes. Other analyses using the evaporation method on axial compressor performance have been done [26, 27], while many other works have been neglected here for brevity. Beyond the one-dimensional model, White and Meacock [28] conducted a pseudo two-dimensional analysis of wet gas compression by calculating multiple mean lines through the flow path. From the droplet trajectory predictions, they estimated the amount of droplet impact on the blades as well as liquid film migration and evaporation.

The evaporation model has been applied to centrifugal compressors using the same assumptions as axial compressor analyses. Abdelwahab [29] coupled the droplet model to a mean line prediction for a centrifugal compressor to estimate the performance effects. Fabrizio et al. [19] attempted to use the droplet model to better understand the thermodynamic effects of the liquid droplets when comparing to test data, and obtained an estimate of polytropic efficiency.

CFD Modeling

Three-dimensional CFD methods have been applied for wet compression in axial compressors. The work of Zheng et al. [30] and Luo et al. [31] have used a multi-stage axial compressor model to study the thermodynamic effects of evaporating liquid droplets on aerodynamic performance. These models, similar to the one-dimensional methods, only account for the thermodynamic effect of the liquid. Khan [32] conducted a two-dimensional CFD study to compare the predictions between using the discrete phase model or a multiphase model. The difference between the two models is in the calculation of the second phase. The discrete phase model follows the method of previous studies that calculate individual droplet trajectories using a force-balance on the droplet while the multiphase method treats the liquid as a continuum and solves the momentum and energy equations. For both comparisons, a small amount of liquid mass is injected into the domain equivalent to 10 μ m droplets for the discrete phase simulations. The results were nearly identical

between the discrete phase and multiphase models; however, the multiphase models present a clearer picture of the liquid distribution near the compressor blades. In other words, the concentration of liquid film on the pressure side of the blades and leaving the blade trailing edge is explicitly seen in the multiphase results

IMPORTANT CURRENT RESEARCH TOPICS

Compressor Aerodynamic Performance

The primary application where wet gas compression is being considered is for subsea gas extraction. In this application and many others, the important operating parameters for a compressor are pressure head and flow rate. Operators desire to run the compressor in such a way to obtain enough pressure head to transfer the gas from the production field to shore or an off-shore platform at a desired flow rate and delivery pressure. If the compressor cannot generate enough pressure head, then the flow rate will be reduced or the delivery pressure will be lowered or both. Both of these parameters will impact the production of the gas field.

Another factor to consider is that over time the gas field depletes to lower compressor suction pressure. As a result, the delivery pressure and mass flow rates will be lower for both dry and wet applications. However, if the performance of the compressor in wet conditions is influenced by the suction pressure, then the variation must be well understood for operation of the compressor.

When compressors are selected for gas field production operation, they are designed and selected to have an operating map that will cover the various operating conditions that are expected. If the performance of the compressor significantly changes due to the presence of liquid, then this will cause limitations in the operation of the compressor. Figure 1 shows a graph of the performance of a two stage centrifugal compressor in dry and wet conditions. The dry condition is shown as black lines and the wet is individual data points. The wet condition data points clearly show when the compressor is subjected to wet conditions, the performance changes. Therefore, the compressor in a gas field may not operate as needed if exposed to wet conditions.

To combat this issue, compressor manufacturers, users, and research institutions have been actively trying to find appropriate methods to predict compressor performance in wet gas conditions. At the core of this issue is the change in the aerodynamic performance of the compressor. When liquid is introduced into the flow stream, the temperature ratio across the compressor drops, the pressure ratio changes, the power consumption increases, and the flow rate is limited. Some of these influences are related to thermodynamic type issues (temperature ratio decreases because you have a higher mass of fluid with a higher heat capacity, which requires more energy to have a temperature change) while other influences are related to aerodynamics. For instance, the blade shape essentially changes as a liquid film flows across the compressor blades and can affect the flow near the blade surface. A study by Grüner et al. [33] qualitatively showed through observations that wet gas flow around a single compressor blade results in a liquid film flowing along the blade. They concluded that the liquid film contributes to early separation on the airfoil to result in reduced aerodynamic

performance. To illustrate the effect of wet gas on compressor power requirement, Gilarranz et al. [34] presented a simple correlation of the relationship between wet and dry power requirement based on the mass flow of the liquid and gas. Converting the correlation to the common wet gas parameter of LMF, the ratio of wet-to-dry power is found to agree well with experimental data (Figure 2) when LMF is less than 50%. It should be noted, however, that this correlation assumes that compressor efficiency is not affected by the liquid in the compressor.

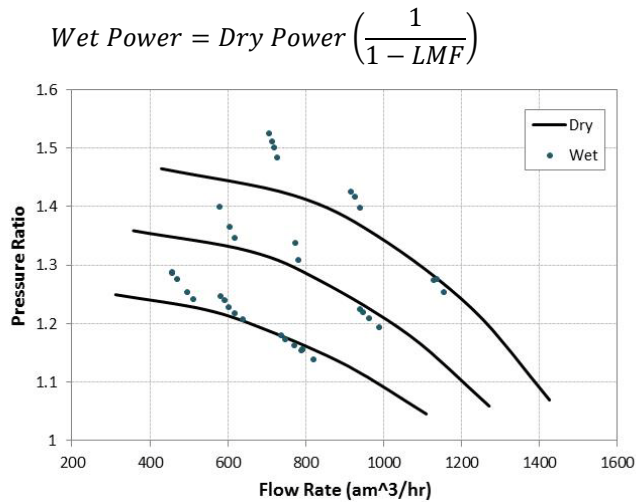

Figure 1. Two Stage Compressor Map Showing Variation between Dry and Wet Performance

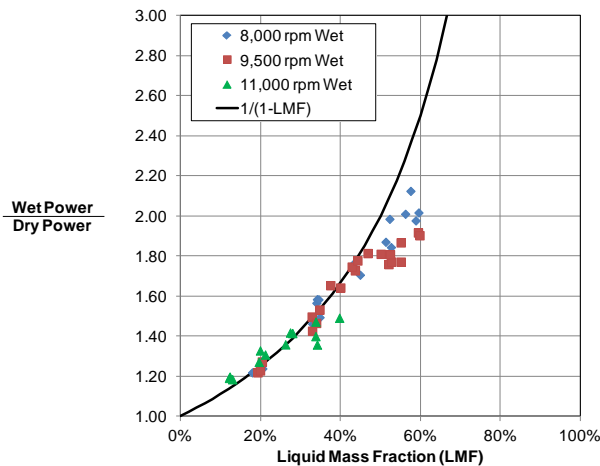

Figure 2. Comparison of Correlation from Gilarranz et al. [34] to Test Data

Compressor Rotordynamics

Another important part of compressor operation is mechanical stability; whereby operating outside of the normal operating regime can result in significant physical damage to the machine. Mechanical stability is even more critical for subsea applications due to the fact that the compressor is essentially inaccessible for repair on the ocean floor. Most subsea compressors are being designed for 5 years continuous running before an overhaul is required.

The influence of the wet gas conditions on mechanical stability is still unclear. Brenne, et al. [3] found that there was

little influence of the wet conditions on the radial vibrations. Ransom, et al. [1] also indicated little influence of wet gas conditions on radial vibration. However, they did find that the axial vibration was influenced by the wet conditions. With the limited published literature on mechanical stability with wet gas conditions, it is difficult to draw general conclusions. More experimental research on the influence of wet gas conditions on the stiffness and damping of internal components is necessary.

Erosion

In wet gas conditions, there is a potential for erosion of internal compressor components. There are many studies on erosion of metallic surfaces by a gas/liquid flow stream. One example is the erosion of steam turbine blades [35, 36, 37]. Pacheco et al. [38] evaluated several steam turbine erosion models and adapted one for wet gas compressions.

Little or no experimental data has been published specifically on erosion in the wet gas conditions described above. However, validated models developed in other applications can be applied to the wet gas applications given that important parameters such as material hardness, droplet size, and droplet velocity are matched to the wet gas application

System Performance

Much of the focus of research has been on quantifying/predicting the performance of the compressor with wet gas conditions. It is important to note that the piping, valves and other items connected to the compressor also influence the compressor operation. One area that has lacked significant development is modeling of the full system exposed to wet gas conditions. There are several system performance considerations that need to be taken into account when selecting a compressor and designing the piping system connected to the compressor such as system resistance, temperature effects, slugging issues, and two-phase flow modeling. For example, liquid slugging upstream of the compressor can cause the compressor to surge by momentarily starving the compressor of gas flow

Liquid Separation

Liquid separation is an important topic for wet gas compression research because the outlet of the separator is typically the inlet of the compressor. Separator footprint is being minimized for subsea systems which can result in decreased separation efficiency. Therefore, it is important that the separation efficiency be known for selection of the compressor to estimate how much liquid will enter the compressor.

Liquid Flow Profiles

As mentioned above, it has been seen in testing that varying droplet size does not cause variation in compressor performance if the liquid flows through a length of suction pipe. As the flow stream travels along the suction piping, the liquid distribution will develop into a natural two-phase flow that is determined by the pipe geometry and flow conditions. For example, liquid injected as droplets may coalesce into larger droplets or a river at the bottom of the pipe, resulting in annular or stratified flow. The development of the two-phase flow regime results in a somewhat consistent flow profile for

the liquid at the inlet of the compressor. This is especially true for any suction piping that has elbows or sharp turns that the flow experiences.

Currently, there is no research that identifies a desired flow profile for the gas/liquid mixture at the inlet. For instance, it is not known if small droplets or a liquid film would allow for higher compression efficiency. With the effect of the liquid distribution on compressor performance, future compressor inlets could be designed to achieve the desired flow profile.

Slugging

Depending on the layout of the compressor piping and valves, it is possible to generate liquid slugs upstream of the compressor. Slugs can be generated from vertical piping, tight flow restrictions, or very low gas velocity. Liquid slugs entering the compressor will cause the compressor to surge and should be avoided. Liquid slugging is primarily a concern for wet gas compressor installations without an upstream liquid separator. Compressor installations that utilize an upstream liquid separator have low risk of slugging.

WET GAS COMPRESSOR TEST SET-UP

There are many challenges that are presented when constructing and performing a compressor performance test in wet conditions. In the laboratory setting, matching the actual conditions is not always possible or desired. Often a smaller scale test at less severe conditions is convenient for gaining understanding into basic phenomena. This provides some simplification to the testing, but there are still many systems that must be operated and tuned to work in the desired conditions.

A typical wet gas test set-up in a laboratory with air and water is described below. This includes a review of various systems needed for a wet gas test and the challenges associated with operation of these systems.

General Arrangement

In a laboratory setting, wet conditions are simulated for testing by injecting liquid somewhere upstream of the compressor. When the liquid conditions are created, it is important to have tight control on the amount of gas and the amount of liquid flowing into the system such that specific Liquid Volume Fractions (LVF) and Liquid Mass Fractions (LMF) can be generated. In addition to generating the appropriate LVF and LMF, the loop must be capable of reaching steady operating conditions and measuring the compressor performance.

Figure 3 shows a typical dry compressor closed test loop. The test compressor is labeled C-101. The piping connected to the compressor has a control valve, a gas cooler, and instrumentation to measure pressure, temperature, and flow (orifice meter run). A few other features include the sealing air system, the motor and gearbox, and the loop blow-off silencer. Note that in dry compressor performance tests, pressure and temperature are typically adequate for measuring the compressor performance. In wet compressor performance tests, however, additional equipment and measurements are needed for the liquid.

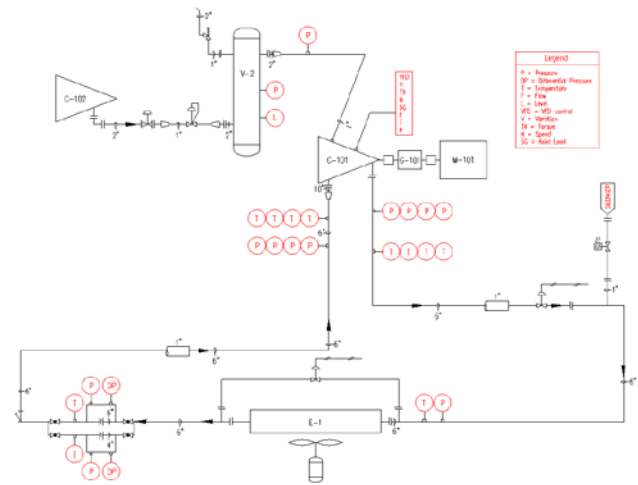

Figure 3. Dry Compressor Test Loop

Figure 4 shows the dry compressor test loop with the added equipment necessary for wet performance testing highlighted in blue. Some of the key components include:

- Liquid storage tank – Needed to have volume of fluid at pump suction and to generate enough NPSH
- Liquid pump – Used to pressurize fluid for injection into the gas loop
- Liquid flow meter – Measures the flow rate of liquid into the gas loop to control LVF and LMF
- Liquid Injection system – Introduces liquid into flow loop in desired pattern (droplets, film flow)
- Liquid/gas separator – Removes the liquid from the gas before gas returns to suction of compressor. Liquid is flowed back to tank.
- Liquid cooler – Removes heat from liquid absorbed during compression process
- Control valves – Used to control flow of liquid through pump, out of liquid/gas separator, and through cooler

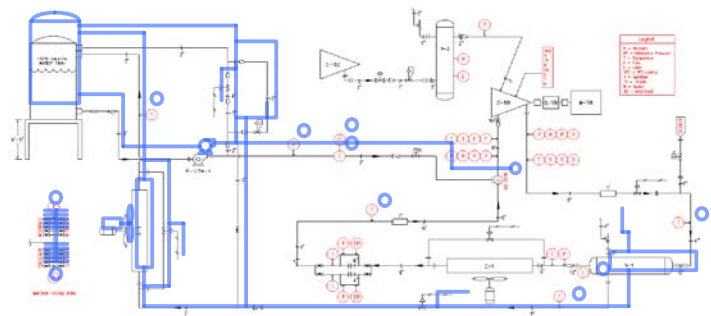

Figure 4. Wet Compressor Test Loop

Liquid Injection

The liquid injection system introduces the liquid into the gas flow. This is comprised of the tank, pump, control valve, instrumentation, and injectors. In a laboratory setting, researchers typically seek to achieve a specific flow profile (droplets or film flow) at the injection location. If injecting water droplets, there is typically a desired mean droplet diameter.

Typical injection systems have a fixed number of injection nozzles and allow for flow through all or a subset of those nozzles. Injection nozzles have a relationship between the average droplet diameter, pressure differential across the nozzle, and the flow rate through the nozzle. The pressure differential usually drives the droplet size and the flow rate through the nozzle. When injecting liquid into the flow stream, the average droplet diameter and the flow rate (LVF) are fixed. Therefore, a fixed pressure differential must be maintained across the injector nozzles. As a result, the flow rate can only be varied incrementally by opening or closing individual injector nozzles. Figure 5 shows the relationship of pressure differential to droplet diameter and flow rate for a typical nozzle where the solid circle indicates the desired average droplet size of 400 μm . To achieve this average droplet diameter, the pressure differential must be 3.2 bar with a provided flow rate of 6.5 gpm. Table 1 shows the various flow rates and LVF that could be achieved with up to 10 nozzles using a fixed pressure differential of 3.2 bar. There is a large range of flows available based on nozzle configuration; however, experimental testing is usually requires tests at specific target values. In wet gas testing, typical target LVF values are 0.5, 1, 1.5, 2, 2.5, and 3%. With the available flow rates listed below, the 0.5, 1, and 2.5% targets could not be met while providing a consistent mean droplet size.

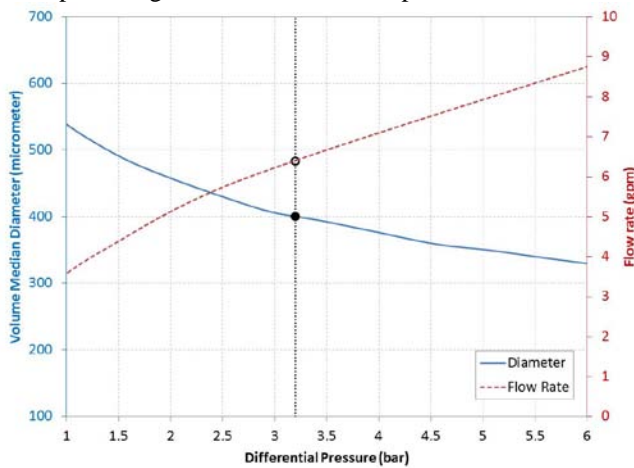

Figure 5. Injector Nozzle Droplet Diameter, Flow Rate, and Differential Pressure Curves for Fixed Average Droplet Diameter

If there is some leniency on the average droplet diameter, then the pressure differential across the injector nozzles can be varied to allow other target LVF values to be met. Figure 6 shows that if the average droplet size can be varied from 350 to 450 μm then this allows for a variation in flow from 5.3 to 8 gpm. The range of LVF that can be achieved with a different number of nozzles is outlined in Table 2. With leniency on

average droplet diameter, almost every LVF can be achieved.

Table 1. Liquid Flow Rate and LVF vs. Number of Nozzles Open for Fixed Average Droplet Diameter

No. of Nozzles Open	Liquid flow rate (gpm)	LVF (500 ACMH gas flow)
1	6.5	0.3%
2	13	0.6%
3	19.5	0.9%
4	26	1.2%
5	32.5	1.5%
6	39	1.7%
7	45.5	2.0%
8	52	2.3%
9	58.5	2.6%
10	65	2.9%

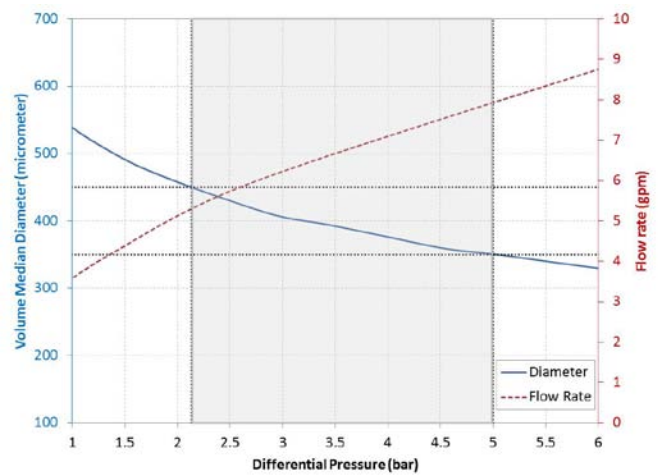

Figure 6. Injector Nozzle Droplet Diameter, Flow Rate, and Differential Pressure Curves for Range of Average Droplet Diameter

Table 2. Liquid Flow Rate and LVF vs. Number of Nozzles Open for Range of Average Droplet Diameter

No. of nozzles Open	Water flow rate (gpm)		LVF (500 ACMH gas flow)	
	Min	Max	Min	Max
1	5.3	8	0.2%	0.4%
2	10.6	16	0.5%	0.7%
3	15.9	24	0.7%	1.1%
4	21.2	32	1.0%	1.4%
5	26.5	40	1.2%	1.8%
6	31.8	48	1.4%	2.1%
7	37.1	56	1.7%	2.5%
8	42.4	64	1.9%	2.8%
9	47.7	72	2.1%	3.2%
10	53	80	2.4%	3.5%

To be able to achieve the control of the flow rate, droplet size, and pressure differential as discussed above,

provisions must be in place for control of the pump flow rate and pump discharge pressure. The configuration shown in Figure 4 allows for pump control using a pump bypass loop with a fixed-speed pump. Pump discharge pressure is maintained at or near a fixed value during all testing. The flow rate from the pump exit is also fixed, but a portion of the flow is diverted back to the tank using the bypass loop. An actuated control valve on the bypass loop is used to control the liquid flow rate to the injection system.

The control valve used for adjusting the flow rate to the injection system should have the capability to make small incremental changes (on the order of 1% change in valve position), which is important to reach specific LVF values. Also, the valve should be sized such that the full flow from the pump can flow through the control valve to the tank without exceeding the manufacturer recommended velocity limits. During start-up of the pump, it is important that the control valve be wide open and allow flow only back to the tank. This will avoid introducing any unexpected liquid into the gas flow stream that could flood the compressor. After startup, the control valve should slowly be closed to start introduction of liquid into the flow stream. Moving too quickly to introduce a large amount of liquid flow to the compressor could cause unexpected damage to the compressor.

The liquid injection system also requires pressure measurement, temperature measurement, and flow measurement. The pressure measurement should be placed as close to the injection location as possible. If the pressure measurement is placed far upstream of the injection system, then the actual differential pressure across the injector nozzles will be unknown due to line losses. The temperature measurement should also be placed as close to the injection location as possible. This measurement allows the test operator to determine the temperature difference between the gas and liquid temperatures at the injection location. Researchers are interested in both the identical and varying temperature between the gas and liquid. The gas and liquid at the same temperature is representative of a gas/liquid flow at the suction of the compressor. If the gas temperature is higher than the liquid temperature, this could be representative of a compressor with a side stream flow.

The liquid flow measurement should be made with a flow meter that has sufficient accuracy to measure the lowest liquid flow rate (lowest LVF on left hand side of map near surge at lowest speed) but still be able to handle the highest liquid flow rate (highest LVF on right hand side of map near stonewall at highest speed). Since the liquid flow rate is dependent on the desired LVF and the flow rate of the compressor (varies across the map) it can vary significantly (over 10:1 ratio). For example, the dry compressor map shown in Figure 1 has a minimum flow (at the lowest speed) of 320 ACMH and a maximum flow (at highest speed) of 1450 ACMH. If the minimum and maximum LVFs were 0.5% and 3%, respectively, this means that the liquid flow rates would need to be 7 and 197 gpm, resulting in a 27:1 ratio.

Gas/Liquid Separation

A gas/liquid separator is used in the test loop to remove the liquid from the flow stream after it has traveled through the compressor. This allows control of LVF and LMF at the suction of the compressor. The separator efficiency should be

sufficient to remove enough liquid to have the desired accuracy for LVF or LMF. Note that there is no instrument placed after the separator to detect how much if any liquid is present. Therefore, if the separator does not have sufficient liquid separation efficiency, the measured LVF or LMF can be skewed to an unknown value.

During testing at wet conditions, the liquid must be removed from the separator to prevent the separator from overflowing. Also, in a closed loop system the pressure in the loop will increase as the separator level increases. Alternatively, the loop pressure decreases with decreasing liquid level in the separator. It is recommended that a control valve be placed on the liquid exit of the separator to control the liquid flow leaving the separator within 1% opening increments. With this control valve, the flow rate of the liquid out of the separator can be matched to the flow rate into the separator. This will allow the separator level to remain constant and the pressure in the test loop to be steady. Figure 7 shows an example of a system where a control valve was not used to regulate the liquid flow out. Instead, a solenoid valve was used and the liquid was flowed out of the separator intermittently. This resulted in significant pressure fluctuations in the process (0.5 bara pressure fluctuations).

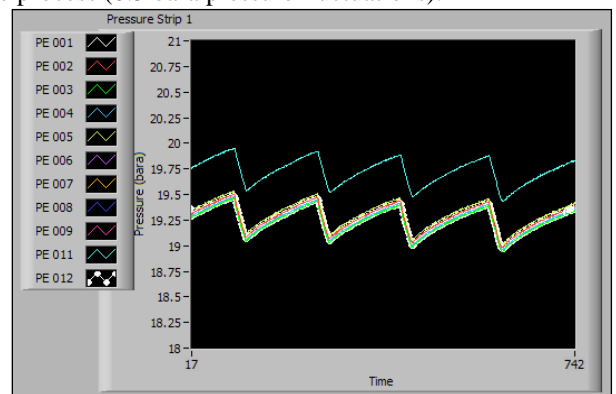

Figure 7. Pressure Fluctuations in a Test Loop Due to Intermittent Opening and Closing of a Solenoid Valve on Separator Liquid Exit

Sealing on the Compressor

Compressors in dry operation can have a variety of different seals including labyrinth seals, brush seals, and dry gas seals. These sealing systems are designed to operate with dry gas present in the seal. In wet gas operation, both gas and liquid are present in the flow stream which means that there is high likelihood that liquid can enter the sealing area. The authors of this paper primarily have experience with using labyrinth seals in wet conditions.

When using labyrinth seals, purging gas at a pressure higher than the compressor suction pressure is required to keep liquid from entering the seals. It is important to note that changes between dry and wet conditions, speed, and operation changes can lead to pressure fluctuations at the suction of the compressor. Some of these changes will cause the suction pressure to increase, which could exceed the purge gas pressure if not monitored closely. If the suction pressure exceeds the purge gas pressure, a mixture of liquid and gas can enter the labyrinth seals. It should be noted that the authors have found that liquid enters labyrinth seals even with

a pressure differential between the purge gas and compressor suction. The movement of the liquid from compressor suction to the labyrinth seals may be due to secondary effects in the sealing system, and is currently being investigated.

The condition and clearance of the labyrinth seals is also important. The seals cannot have large clearances due to wear, which will not keep the liquid inside the compressor

Pressure, Temperature, and Flow Rate Measurement and Control

With any research-grade testing, it is important to control flow rate, pressure, and temperature. The flow rate of the gas and liquid are easily controlled with actuated valves. The liquid flow rate control has been previously discussed. The gas flow rate is controlled by varying the opening of an actuated control valve on the discharge of the compressor. Flow measurement of the gas flow rate can be done with conventional gas measurements techniques. However, it is important that the gas flow rate be measured at a location that has “dry” gas only. When testing in a closed loop, the gas will likely be saturated, but no liquid droplets should be present (unless there is significant carryover from the separator). Figure 1 shows that the gas flow measurement as an orifice meter run which is placed after gas/liquid separation and the gas cooler. Two orifice meters were used for this loop to improve the accuracy of flow measurement in both the lower and upper flow ranges.

The pressure in the loop is controlled by two mechanisms. The first mechanism, the separator liquid level, has already been discussed. Note that it is desirable to have a somewhat consistent separator level, but this level can be used to control the pressure inside the loop if needed. The second pressure control mechanism is the source for pressurizing the closed loop. In the test loop being discussed, the loop is pressured through the seal purging system. The seal purging system continuously has a flow of gas into the seal area to create a seal buffer that sustains the pressure in the loop. Seal purging systems can be set up with automatic or manual valves to control the flow and pressure of the gas going into the seal chambers. The authors of this paper, however, have found that a manual pressure regulator is sufficient for controlling the seal purging pressure. The primary issue with the seal purging system is that it cannot automatically allow the seal purge pressure to increase (in case of a transient type of event that causes the suction pressure to increase, as discussed above).

It is important to note that since there is more than one component used to control sealing pressure; these two devices will interact with each other. For example, if the manual pressure regulator on the seal purging system is set at 20 bar, but the current test is being conducted at 18 bar, the separator level liquid will have to be continually decreasing in order to maintain a constant 18 bar pressure. This is because the seal purging system is allowing mass to flow into the compressor (instead of just creating a buffer). The liquid level in the separator must continually decrease to keep adding volume to the test loop to allow space for the mass of the purge gas being added to the loop. This explanation may seem cumbersome, but this control methodology was used several times in past testing to maintain a fixed pressure for a testing.

Pressure control is also important for start-up and shutdown. During start-up of the test loop, it may be necessary

to increase the pressure at a specified rate. This is especially true for any static measurement devices such as pressure scanners that may not be able to allow for fast pressure transients. This same consideration is true for depressurizing the system.

There are various methods for measuring pressure in a wet gas system. In many compressor performance testing loops, pressure measurements are made via pressure scanners. In wet systems, pressure scanners are difficult to use, because the pressure lines fill with liquid during testing. It is necessary to purge these lines intermittently to remove the liquid and also protect the pressure scanner (if a dry-only scanner is used). Purging systems can be elaborate and costly. However, these systems are often necessary to obtain pressure measurements inside the compressor or to acquire a large number of pressure measurements in a cost effective manner. For static pressure measurements on piping, direct mounted probes are recommended. This eliminates the pressure tubing and the purging system. Note, that the orientation of the probe is important. If a probe is oriented on the bottom of the pipe, the sensing face will almost always be flooded with liquid.

Temperature control is important to be able to meet desired conditions and maintain consistent test conditions for comparison at a later time. In wet gas testing, the three primary temperatures that must be controlled are the gas inlet temperature, liquid inlet temperature, and combined gas/liquid inlet temperature. The gas/liquid inlet temperature is a function of the gas/liquid mixing upstream of the compressor and thus is controlled by the flow in the upstream piping.

During a wet test, the liquid is heated as it flows through the compressor. In a closed system, the heat gained by the liquid must be removed before it re-injected. A separate cooler for the gas and liquid flows is recommended for precise control. In past testing, a single cooler for the mixed flow stream has been used, but it was found that the liquid was not adequately cooled in this configuration and the liquid temperature slowly increased overtime. Therefore, a steady liquid inlet temperature could not be maintained. With separator coolers, a steady liquid inlet temperature can be maintained.

Since a separate cooler is needed for both gas and liquid, this means that cooling occurs after separation. When testing a wet system, the gas is fully saturated with liquid at all points in the test loop. Therefore, after the gas has cooled, there could be some liquid drop out. If the cooler is placed after the separator, then this liquid will travel to the suction line where injection occurs and the liquid will not be accounted for in the LVF or LMF measurement. However, the liquid drop out can be estimated. Past experience testing with two separate coolers has shown that there is an insignificant amount of liquid drop out after the gas cooler, within the measurement uncertainty of the liquid flow rate. The primary situation where this could be a concern is for control of liquid flow at very low LVFs.

Temperature measurements can be made on a wet system with conventional temperature sensors. The primary thing to note about temperature measurement is that the location of the sensing element can influence the temperature reading. For example, the liquid may be stratified flow along the bottom of the pipe; whereby, the temperature sensing element placed at the bottom of the pipe will be reading liquid temperature while

other temperature sensors may be reading gas temperature at the top of the pipe.

GENERAL TRENDS OBSERVED IN WET GAS PERFORMANCE TESTING

From the available wet gas compressor performance data presented in the literature, there are consistent trends showing that as more liquid is added to the compressor, the compressor power increases (reduced efficiency), pressure ratio increases, and gas volume flow rate decreases. It is important to note, however, that the effect of wet gas on pressure ratio is dependent on the operating condition because the pressure ratio may not be affected at high volume flow rates. The test data used to illustrate the performance trends are from a past experimental program completed at SwRI [1, 2], as illustrated in Figure 8.

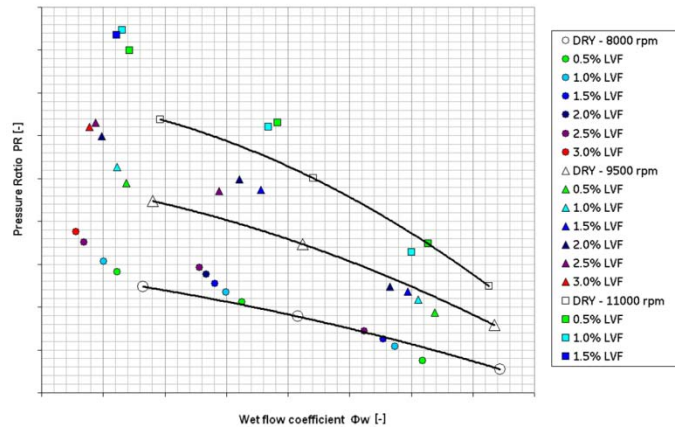

Figure 8. Wet Gas Test Data Set [2]

Effect of wet gas operating parameters on performance

When defining a test matrix for wet gas compression tests, it is easy to get lost in the test variables that may or may not influence the compressor performance. Much of the past testing in the literature focus on density ratio, LVF, gas volume flow, suction pressure, and suction temperature. However, it is possible that other variables may have a significant influence on the compressor operation, such as those that were thought to be insignificant when developing the test matrix. For example, test variables of LMF and air-water temperature difference can sometimes take a backseat to variables of LVF and suction air temperature. To determine the influence of test variables on compressor performance, a multiple regression model is used here to describe which variables should or should not be neglected.

A multiple regression model is a method to estimate a set of outputs for a given set of inputs. In the simplest form, a regression model can be thought of as a linear curve fit.

$$y = \beta_0 + \beta_1 x_1$$

In this simple form, the input is x_1 and the output is y . The magnitude coefficient (β_0) and the variable coefficient (β_1) are results of the regression analysis. When many inputs are monitored for a single output, a multiple regression model is expanded to include variable coefficients for each input. Generally, a multiple regression model can take the form of a first-order or second-order equation. The effect of variable interaction can be included in the regression model, but is

neglected in this paper because the no-interaction models were sufficient to predict the output variables.

First-Order Regression Model:

$$y = \beta_0 + \beta_1 x_1 + \beta_2 x_2 + \dots$$

Second-Order Regression Model:

$$y = \beta_0 + \beta_1 x_1 + \beta_2 x_1^2 + \beta_3 x_2 + \beta_4 x_2^2 + \dots$$

Using the performance data described in the previous section, first- and second-order regression models are presented to determine which test parameters most affect compressor performance. The results of this analysis can be used to guide future test programs. The test parameters considered for the regression models are listed in Table 3 with their associated order of magnitude. Because of the large difference in orders of magnitude among the test parameters, the variable coefficients of a regression model cannot be used to compare the relative importance of the variable. In other words, the regression model built for compressor pressure ratio may have a very low variable coefficient (β) for compressor speed to counter the large order of magnitude of the speed values. As an alternative, the test parameter values can be expressed as a value in terms of standard deviation above or below the mean value. The result is a set of test parameters that have similar order of magnitude – which translates to improved accuracy of the regression model, and a set of variable coefficients that can be compared to show relative importance. The model outputs are also standardized

$$\hat{x}_1 = \left(\frac{x_1 - \bar{x}_1}{s_1} \right)^2$$

In presenting the regression analysis, the adequacy of the regression model fit is first verified for both dry and wet compressor test data. Next, the group of test parameters included in the model is investigated to determine if some parameters have no effect on the model fit. Finally, the variable coefficients are presented to show the relative importance of the test parameters used to generate the final regression model. Using the complete set of standardized test parameters, both first-order and second-order regression models are fit to the data to determine which regression form is required for the model fit. A regression model is generated for each test output; compressor pressure ratio, isentropic efficiency, shaft torque, and axial thrust. The initial check of the regression model adequacy is done by comparing the predicted output values to the test data, as shown in Figure 9 and Figure 10. For a perfect model fit, all plotted points would lie on the line with slope of 1. From Figure 9, it can be seen that the first-order regression model is sufficient to predict all the test output variables except isentropic efficiency, where a large amount of scatter is seen from the line of perfect fit. In comparison, the second-order regression model plotted in Figure 10 shows even better agreement than the first-order model for all output variables. With the second-order model, the pressure ratio, torque, and axial thrust variables are much better predicted than the first-order model, and the compressor efficiency is predicted within an acceptable amount of scatter. The fit of the regression models is quantitatively compared using the R2 error estimate in Table 4, adjusted for the number of input parameters. An R2 value of 1.0 indicates a perfect fit

of the model to the test data, while an R2 value of 0 indicates a poor fit. It can be seen from the comparison of regression models that the second-order model fits both dry and wet performance data very well, while the first-order model was more successful to predict wet performance data than dry performance data. The reason the first-order model was better

suiting for wet data than dry data may be due to the influence of the liquid parameters damping the effects of the dry parameters. In any case, the second-order model is determined to be sufficient for this analysis and outperforms the fit of the first-order model which was insufficient to predict the isentropic efficiency of the dry data.

Table 3. Test Parameters and Order of Magnitude

Test Variable	Units	Order of Magnitude	Range of Values
Speed	[rpm]	10^3	8,000 – 11,000
Suction Pressure	[bar]	10^1	19 – 20
Suction Air Temperature	[°C]	10^1	42 – 64
Air-Water ΔT	[°C]	10^0	-8 – 10
Air Volume Flow	[ACMH]	$10^2 - 10^3$	460 – 1160
Water Volume Flow	[gpm]	$10^1 - 10^2$	0.6 – 5.8
Water-Air Density Ratio	[-]	10^1	45 – 50
LVF	[-]	10^{-2}	0.3 – 3.0%
LMF	[-]	10^{-1}	12 – 60%

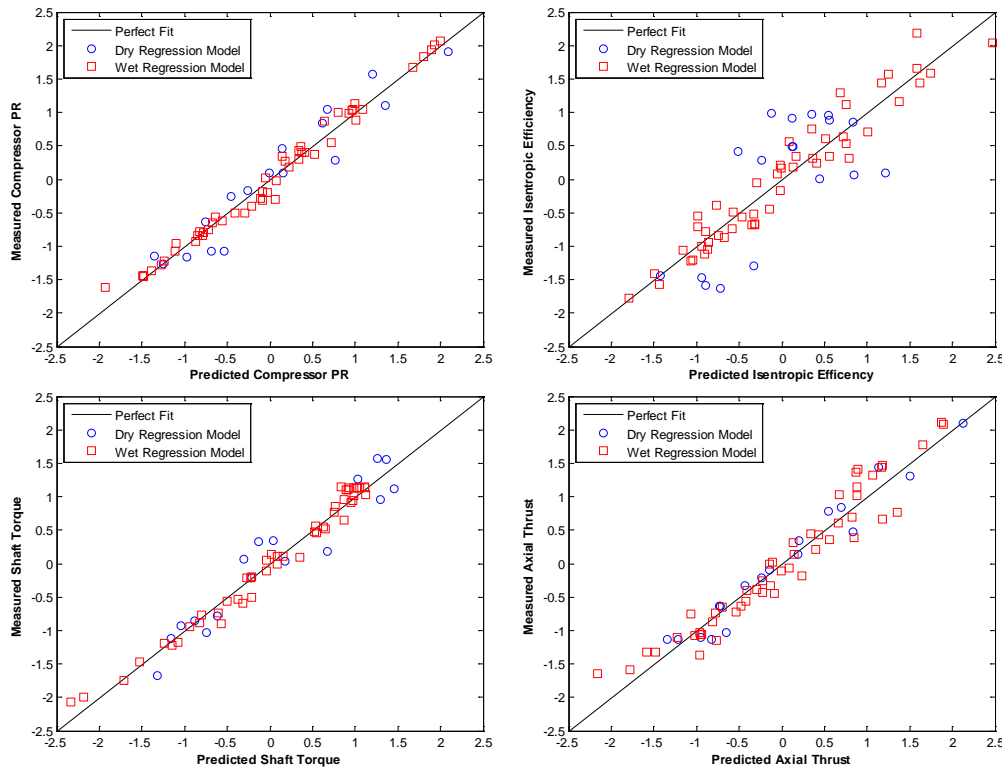

Figure 9. Comparison of First Order Regression Models to Measured Data (Regression Variables: N , P_{suc} , T_{suc} , Q_{air} , $\Delta T_{air-water}$, LMF_{nom} , LVF_{nom})

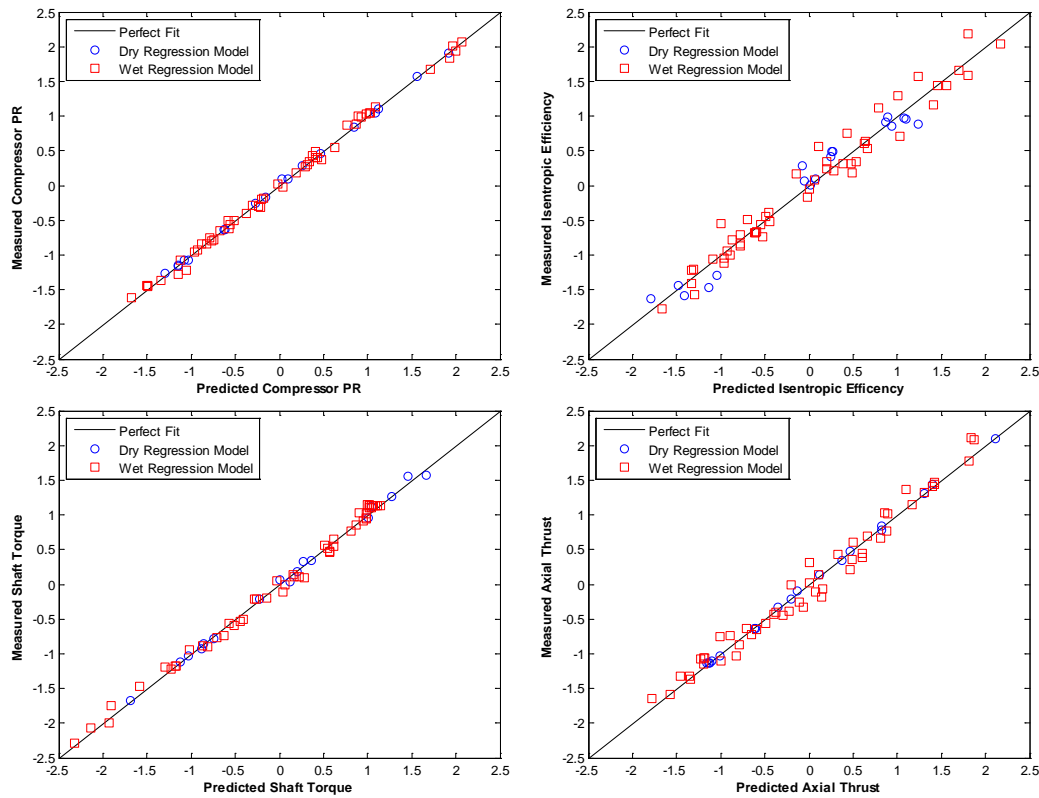

Figure 10. Comparison of 2nd Order Regression Models to Measured Data
 (Regression Variables: N , P_{suc} , T_{suc} , Q_{air} , $\Delta T_{air-water}$, LMF_{nom} , LVF_{nom})

Table 4. Regression Model R^2 Goodness of Fit

		Axial Thrust	Shaft Torque	Compressor PR	Isentropic Efficiency
Dry Regression Model	1 st Order R^2 Fit	0.95	0.89	0.89	0.35
	2 nd Order R^2 Fit	1.00	1.00	1.00	0.96
Wet Regression Model	1 st Order R^2 Fit	0.92	0.98	0.98	0.92
	2 nd Order R^2 Fit	0.98	1.00	1.00	0.96

Using the second-order regression model, the set of inputs was investigated to determine which of them were not required to adequately predict compressor performance. A total of 23 variations of the input set were investigated to determine the minimum set required. The adequacy of each variable set is determined using the R^2 fit of the model to the measured test data, as shown in Figure 11. A primary goal of defining the variable set is to determine the importance of LVF and LMF on the model output. The motivation for this exercise is that much of the literature uses LVF as a primary test variable for elevated pressure tests, and LMF as a primary test variable for atmospheric pressure tests. The goal is to determine if one is more important than the other, or if both should be considered. The horizontal axis of Figure 11 is generated to show the set of variables that were combined with the noted LVF or LMF variables. For this data, both nominal and actual LMF and LVF values are compared. Actual values of LMF and LVF are calculated using the gas

volume flow of the wet operating point. Nominal values of LMF and LVF are calculated using the gas volume flow of the corresponding dry operating point. The purpose of investigating nominal values lies in the simplicity of selecting operating conditions for future wet gas testing. The second-order model presented above is shown in Figure 11 as the first variable set that includes both nominal and actual values of LMF and LVF. Moving from left to right on Figure 11 each variable set is reduced by one variable at a time. The influence of using the actual and nominal values of LMF and LVF is seen to affect only the isentropic efficiency and axial thrust by as much as one percent of the R^2 fit. The air-water density ratio was found to not affect the regression model fit, likely because the air-water density ratio is included in the calculation of LMF. Removing the water volume flow rate from the variable set had a small effect on the model fit; however, including LMF and LVF together results in a regression model with similar fit to larger variable sets.

Further reduction of the variable set to remove the air-water temperature difference and air suction temperature results in a significant reduction of the model fit to the output variables. Therefore, the smallest set of input variables found to produce a regression model consistent with larger variable sets is to include the following variables:

- Speed
- LMF
- LVF
- Suction Temperature
- Air Volume Flow Rate
- Air-Water Temperature Difference
- Suction Pressure

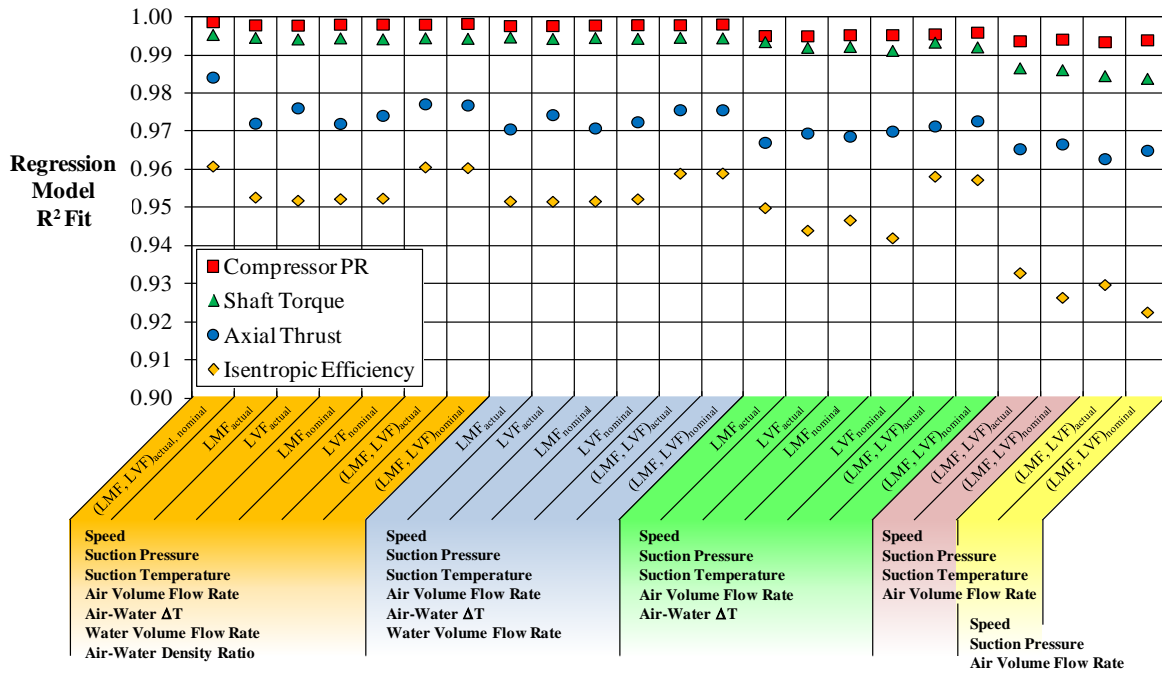

Figure 11. Sensitivity of 2nd Order Wet Regression Model to Selection of Variables

As expected, the water flow rate and air-water density ratio are not required to define an input variable set as long as LMF and LVF are included to account for the density ratio and water flow rate. The unexpected result, however, is that the temperature difference between the air and water has a major effect on the model fit. This suggests that air and water temperature differences are important for wet gas compression. Considering the thermodynamics of compression, it would be expected that the inlet temperature difference would be important. However, the temperature difference has not been thoroughly studied in the literature, and the amount of temperature difference required to significantly affect compressor performance has not been quantified. From the test data set, the maximum temperature difference was less than 10°C; whereby most data points had a temperature difference less than 2°C, as shown in Figure 12. Because only a few degrees of temperature difference were measured for most data points, the air-water temperature difference was not expected to be significant for the regression model.

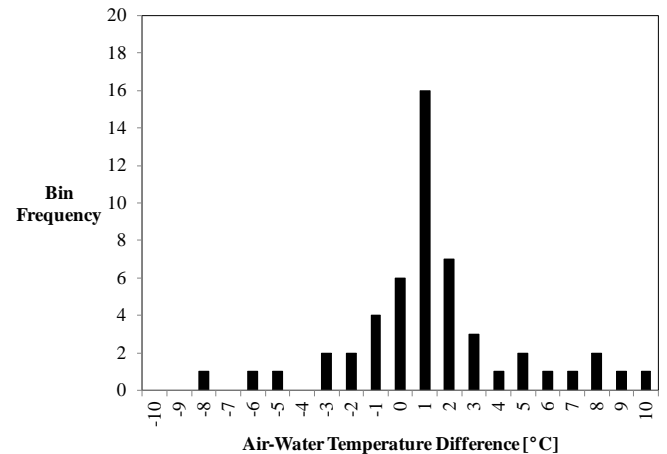

Figure 12. Histogram of Air-Water Temperature Difference for all Wet Gas Data Points

The second-order regression model obtained through the study of variable sets is used to illustrate the relative importance of test variables. The variable coefficients of the regression model are normalized by the maximum variable coefficient and shown in Figure 13 and Figure 14 for dry and wet data sets, respectively. While a regression model for dry gas compressor performance is not of significant importance because dry gas compressor performance is well understood, it is a good check of the regression model results to ensure that the important parameters make sense. From the dry gas regression model, the results make sense that the largest variable coefficients correspond to the expected important test variables. The large variable coefficients for speed and air volume flow are shown to be the most significant for predicting compressor pressure ratio, as expected. Shaft torque is most influenced by suction temperature and speed. Suction temperature is important to torque because the air density

more affected by temperature than pressure change, within the range of conditions of the test data set. Similar to pressure ratio, axial thrust is most influenced by speed and air volume flow. Axial thrust is similar to pressure ratio because the axial thrust of the machine is strongly tied to pressure ratio across the impeller. Lastly, isentropic efficiency is affected most by suction temperature and volume flow, but is shown to have strong secondary effects of suction pressure and speed. Isentropic efficiency has strong influences from most of the test variables because the efficiency calculation incorporates values of pressure ratio and shaft torque, making it the most complex of the output variables. It is also noteworthy that out of the second-order terms in the dry regression model, speed and volume flow are the most significant likely because of their second-order relationship compressor operation that is evident in typical compressor performance maps

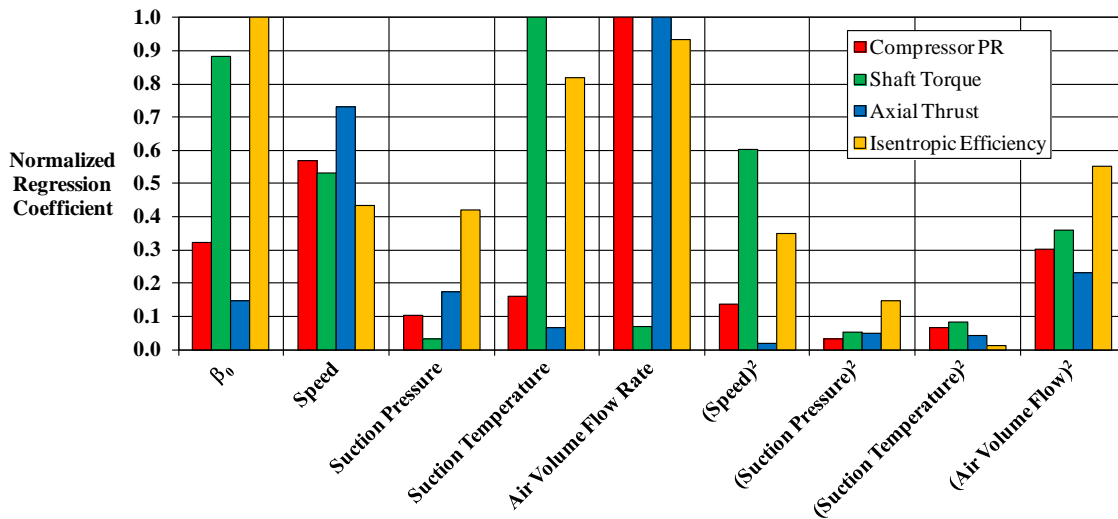

Figure 13. Normalized Regression Coefficients for 2nd Order Dry Model

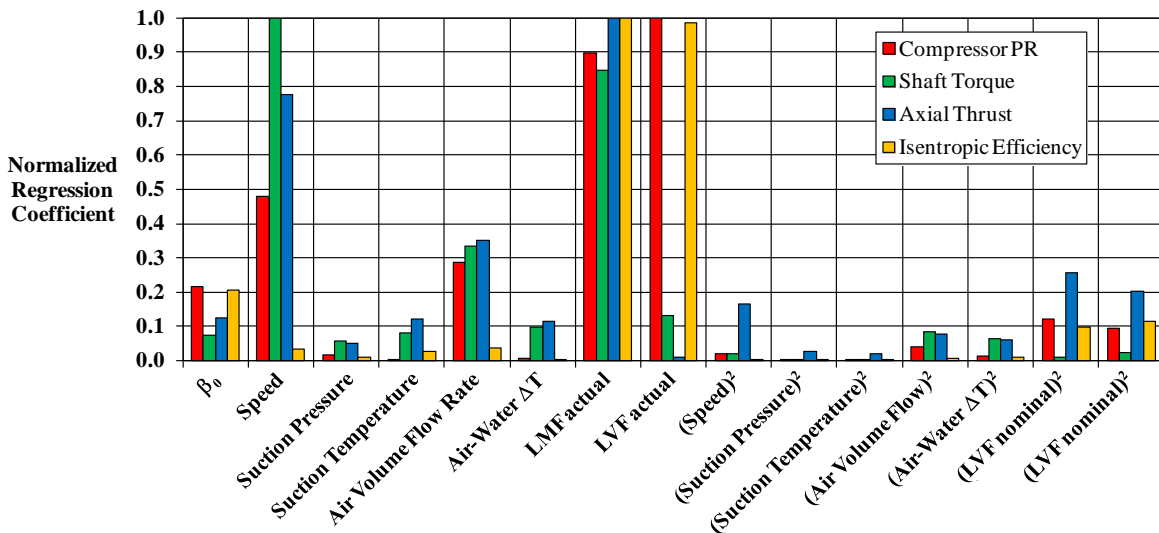

Figure 14. Normalized Regression Coefficients for 2nd Order Wet Model

From the comparison of R^2 fit results, it was found that using either the actual or nominal values of LMF and LVF were acceptable to generate a regression model as long as both LMF and LVF were included in the model. Therefore, the regression model using actual values of LMF and LVF is presented in Figure 14 to be consistent with the available wet gas literature. Similar to the dry gas regression model, wet gas pressure ratio is strongly influenced by speed, and air volume flow rate. However, pressure ratio is also most strongly affected by the LMF and LVF, which is evident in test data showing the increase of compressor pressure ratio as liquid is added to the suction flow. Shaft torque was found to have influential variables of speed and air volume rate similar to the dry regression, but a strong influence from LMF. The variable LVF was found to only have a little more influence on shaft torque than the influence of the air-water temperature difference. The small effect of LVF on shaft torque suggests the strong effect of density ratio on compressor power, which has been documented in test data from the literature. In fact, the dependence of LMF on power is demonstrated in atmospheric test data that measure a significant effect of wet gas on compressor power when the LVF values are nearly zero due to the density ratio of 1,000 to 1. As with the dry gas model, the parameters influencing axial thrust are similar to those influencing pressure ratio; however, axial thrust is not found to be influenced by LVF. The lack of influence of LVF on axial thrust may suggest that axial thrust effects are strongly governed by the density ratio between the gas and liquid affecting the secondary flow through the compressor. The isentropic efficiency was found for the dry gas model to be influenced by all the operating parameters, most notably the suction temperature and air volume flow rate. For the wet

gas model, however, isentropic efficiency is most strongly affected by the LMF and LVF nearly equally. The other operating variables of the compressor do not have as strong an influence on efficiency as the LMF and LVF. It is important to realize that variables such as suction pressure and suction temperature may have an effect on isentropic efficiency, but the effects are not shown because the range of test data from which the regression model is created does not have a large enough variable range to show the influence. To summarize, the sensitivity study of test parameters on wet gas compressor performance uses a multiple regression model to predict the compressor performance using a set of test data. The regression model fit to the measured data was checked using an R^2 fit and sequentially reducing the number of test variables to find the smallest data set possible without significantly reducing the model accuracy. The influential parameters determined from the regression models are shown in Table 5 for both dry gas and wet gas performance. Overall, it was found that the most influential test variables for wet gas performance are the compressor speed, air volume flow rate, LMF, and LVF. It was found that including both LMF and LVF provided better accuracy of the regression model, which indicates that future wet gas testing should consider both LMF and LVF ranges in the test matrix. It is important to emphasize that the sensitivity analysis presented here is specific to the compressor and range of test variables from the data set. For example, all measurements were conducted at nearly constant suction pressure; therefore, the effect of suction pressure is not seen as a driving factor in this study. Future regression models that include a range of suction pressures will likely show it as an influential parameter.

Table 5. Summary of Influential Test Variables

Regression Model Output	Influential Variables for Dry Gas Compression	Influential Variables for Wet Gas Compression
Pressure Ratio	Speed Air Volume Flow Rate	Speed Air Volume Flow Rate LMF actual LVF actual
Shaft Torque	Speed Suction Temperature	Speed Air Volume Flow Rate LMF actual
Axial Thrust	Speed Air Volume Flow Rate	Speed Air Volume Flow Rate LMF actual
Isentropic Efficiency	Speed Air Volume Flow Rate Suction Pressure Suction Temperature	LMF actual LVF actual

FUTURE WET GAS WORK

Analytical

Analytical methods to predict wet gas performance continue on the work of others to define wet gas performance using thermodynamic models or CFD. In either case, analytical work continues to be based on flange-to-flange compressor performance measurements. Considering the work

that has been done to characterize the thermodynamic effect of wet gas, it is obvious that the aerodynamic effect has still not been quantified. The major assumption of the thermodynamic models is that the liquid is in the form of disperse, spherical droplets that follow the gas flow through the compressor. This assumption is valid for axial compressors in power generation applications because the liquid is injected as a fog with droplet diameters on the order of 10 μ m. In Oil & Gas applications,

however, the liquid enters the compressor with a distribution that is determined by the natural two-phase flow regime in the suction piping upstream of the compressor. The liquid entering the compressor is made up of droplets, ligaments, and films covering the flow path surfaces. An example of the liquid distribution for wet gas flow over a blade is illustrated in Figure 15. Because the liquid is not dispersed, spherical

droplets – additional corrections are required for analytical models to account for heat transfer between the gas and liquid phases, as well as the effect of the liquid on the gas flow through the compressor. For example, the liquid film on the impeller blade surface will affect the boundary layer development to potentially reduce aerodynamic performance.

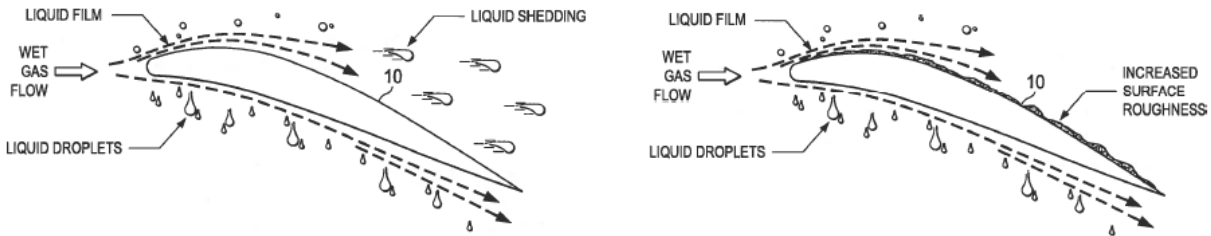

Figure 15. Potential Influence of Wet Gas: (left) Liquid Droplets Leading to Premature Flow Separation or (Right) Liquid Film Significantly Increasing Surface Roughness [39]

The interaction between the gas and liquid for non-ideal liquid conditions is not a simple task, and this is a growing area of interest to improve wet gas predictions. Boundary layer analysis is quite complex to estimate the flow near the air and water interface [40] when trying to model the natural physics. Computational methods are more attractive, but still rely on empirical models for the interaction of the phases. To resolve the complex interactions between gas and liquid phases, computational cost is high due to the number of equations to solve the momentum, energy, and turbulence equations of both gas and liquid phases. Additional equations are included to account for the interfacial communication between the fluids. Furthermore, resolving the fluid inter-phase requires a very fine mesh in regions where the gas and liquid interface is to occur. At this time, CFD solutions for wet gas compression are being done, but information is limited on their accuracy and computational efficiency. Because of the complexity of modeling the multiphase flow while accounting for the natural physics of the gas-liquid interface, SwRI has recently been investigating the use of an alternative computational flow solver using a lattice-Boltzmann (LB) method. Effectively, the LB method arrives at the Navier Stokes equations while utilizing a mesoscopic method for fluid predictions. Advantages of the LB method are that it is implicitly transient, does not require a discretized mesh, and can account for multiphase flows with a few additional equations. Through internal research work at SwRI, the LB method shows promise, but requires more work to accurately predict wet gas aerodynamics.

Experimental

As part of sub-sea technology development, compressor performance and operation at sub-sea conditions are being actively researched at a handful of locations throughout the world. Although wet gas compressor test results have been published in the literature for nearly a decade, the Oil & Gas industry still does not have enough information to confidently predict wet gas performance, mechanical operation, or machine durability for all conditions. While the available wet gas testing has revealed important information on wet gas

compression, much of the research is dis-jointed among a range of compressor designs and operating conditions such that a clear picture of wet gas effects is not possible. As wet gas compressor prototypes are being designed for sub-sea service, more experimental work will be needed to determine the effect of flow path design features on compressor performance. To that end, a harmonized test campaign evaluating the performance and durability of multiple designs in the same test facility can provide directly comparable test data. While aerodynamic performance data is still needed for future compressor designs, future experimental work will likely begin investigating rotor-dynamic, and durability of the machine.

CONCLUSIONS

Test experience from the authors and a review of relevant literature on the subject of wet gas compression has been presented for Oil & Gas applications with centrifugal compressors. Considerations for experimental testing have been presented to discuss a typical test setup in detail and provide insight for selection of loop hardware and control. An overview of analytical work in wet gas compression was presented to show the current state-of-the-art in the literature. A regression analysis was presented to show the significant test variables observed during a wet gas test campaign. Important test variables were found to be dependent on the measurement being made; however, liquid mass fraction was found to be important for measuring compressor pressure ratio, efficiency, torque, and thrust. Liquid volume fraction was found to be important for measuring pressure ratio and efficiency, which suggests the importance of future tests to use fluids that allow for gas-liquid density ratios similar to actual operation. From the regression analysis and the overview of experimental and analytical, suggestions for wet gas work were presented to call attention to areas of wet gas research that require further study.

NOMENCLATURE

LMF = Liquid mass fraction, $\dot{m}_l / (\dot{m}_l + \dot{m}_g)$ (-)

LVF	= Liquid volume fraction, $Q_l/(Q_l+Q_g)$	(-)
N	= Rotor speed	(rpm)
PR	= Pressure ratio	(-)
P_{suc}	= Suction pressure	(bara)
T_{suc}	= Suction temperature	(°C)
Q_{air}	= Volume flow rate of air	(m ³ /hr)
$\Delta T_{air-water}$	= Air-water temperature difference	(°C)

REFERENCES

- [1] Ransom, D., Podestà, L., Camatti, M., Wilcox, M., Bertoneri, M., Bigi, M., "Mechanical Performance of a Two Stage Centrifugal Compressor under Wet Gas Conditions," *Proceedings of the 40th Turbomachinery Symposium*, pp. 121-128, 2011.
- [2] Bertoneri, M., Duni, S., Ransom, D., Podestà, L., Camatti, M., Bigi, M., Wilcox, M., "Measured Performance of Two-Stage Centrifugal Compressor under Wet Gas Conditions," *Proceedings of ASME Turbo Expo*, GT2012-69819, 2012.
- [3] Brenne, L., et. al., "Performance Evaluation of a Centrifugal Compressor Operating Under Wet Gas Conditions," *Proceedings of the Thirty-Fourth Turbomachinery Symposium*, Houston, TX, 2005.
- [4] Knudsen, T., Solvik, N., "World First Submerged Testing of Subsea Wet Gas Compressor," *Proceedings of the Offshore Technology Conference*, Houston, TX, 2011.
- [5] Camatti, M., "Design and Technology Qualification of "BlueC" Subsea Gas Compressor for Ormen Lange," Presentation at the Underwater Technology Conference, Bergen, Norway, 2011.
- [6] Aguilera, L.C.P., "Subsea Wet Gas Compressor Dynamics," Masters Thesis, Norwegian University of Science and Technology, June 2013.
- [7] Torpe, H., "Separation and Related Aspects for Asgard Subsea Compression," Presentation at the Separation Technology Conference, Stavanger, Norway, 2013.
- [8] Bjorge, T., Brenne, L., "Subsea gas compression; Available technology and future needs," The Research Council of Norway, 2010.
- [9] "Press Kit Asgard Subsea Gas Compression," Statoil website, March 9, 2014
- [10] Arntzen, R., Winther, L., "Ormen Lange, Subsea Compression Project," Shell, 2012.
- [11] "Enhanced Recovery through Subsea Compression at Gullfaks," Statoil News Release, May 22, 2012.
- [12] Amundsen, S., "Wet Gas Compression, Impeller Rig," Masters Thesis, Norwegian University of Science and Technology, July 2009.
- [13] Jellum, M., "Wet Gas Compressor Surge Detection," Masters Thesis, Norwegian University of Science and Technology, June 2013.
- [14] Vintersto, T., "Subsea Gas Compression Now and in the Future," Energy Claims Conference, 2013.
- [15] Rogno, H., "Statoils subsea relevante FoU," NC Subsea, Bergen, 2013.
- [16] "Compressor Testing Kicks Off at StatoilHydro's Karsto Laboratory," OilVoice, April 21, 2008.
- [17] Terdre, N., "Subsea compression under review to safeguard Asgard flow Assurance," Offshore, August 2008.
- [18] "Gas Compression from Production thru Transmission," Presented at Gas/Electric Partnership, Houston, TX February 2010.
- [19] Fabbri, M., et. al., "An Experimental Investigation of a Single Stage Wet Gas Centrifugal Compressor," *Proceedings of the TurboExpo Power for Land, Sea and Air*, GT2009-59548, 2009.
- [20] ASME, "Performance Test Code on Compressors and Exhausters," Standard PTC 10-1997.
- [21] Schultz, J.M., "The Polytropic Analysis of Centrifugal Compressors," *J. Engineering Power*, pp. 69-82, 1962.
- [22] Huntington, R.A., "Evaluation of Polytropic Calculation Methods for Turbomachinery Performance," ASME Turbo Expo, 85-GT-13.
- [23] Hundseid, O., Bakken, L.E., Helde, T., "A Revised Compressor Polytropic Performance Analysis," ASME Turbo Expo, GT2006-91033
- [24] Hundseid, O., Bakken, L.E., "Wet Gas Performance Analysis," ASME Turbo Expo, GT2006-91035.
- [25] Härtel, C., Pfeiffer, P., "Model Analysis of High-Fogging Effects on the Work of Compression," ASME Turbo Expo, GT2003-38117.
- [26] Horlock, J.H., "Compressor Performance with Water Injection," ASME Turbo Expo, GT2001-0343.
- [27] White, A.J., Meacock, A.J., "An Evaluation of the Effects of Water Injection on Compressor Performance," ASME Turbo Expo, GT2003-38237.
- [28] White, A.J., Meacock, A.J., "Wet Compression Analysis Including Velocity Slip Effects," *J. Engineering Gas Turbines Power*, **133**, 2011.
- [29] Abdelwahab, A., "An Investigation of the Use of Wet Compression in Industrial Centrifugal Compressors," ASME Turbo Expo, GT2006-90695.
- [30] Zheng, Q., Shao, Y., Zhang, Y., "Numerical Simulation of Aerodynamic Performances of Wet Compression Compressor Cascade," ASME Turbo Expo, GT2006-91125.
- [31] Luo, M., Zheng, Q., Sun, L., Deng, Q., Yang, J., "Numerical Simulation of an Eight-Stage Axial Subsonic Compressor with Wet Compression," ASME Turbo Expo, GT2013-94486.
- [32] Khan, J.R., "Comparison between Discrete Phase Model and Multiphase Model for Wet Compression," ASME Turbo Expo, GT2013-96022.
- [33] Grüner, T.G., Bakken, L.E., Brenne, L., Bjorge, T., "An Experimental Investigation of Airfoil Performance in Wet Gas Flow," ASME Turbo Expo, GT2008-50483.
- [34] Gilarranz, J.L., Kidd, H.A., Chochua, G., Maier, W.C., "An Approach to Compact, Wet Gas Compression," ASME Turbo Expo, GT2010-23447.
- [35] Krzyzanowski, K., "The Correlation Between Droplet Steam Structure and Steam Turbine Blading Erosion," *Journal of Engineering Gas Turbines Power*, vol. 96, pp. 256-266, July 1974.

- [36] Luo, S., et. al. "Theoretical Model for Drop and Bubble Breakup in Turbulent Dispersions," *AICHE Journal*, vol. 45, pp. 1225-1233, 1996.
- [37] Joliffe, K., "The Development of Erosion Damage in Metals by Repeated Liquid Droplet Impacts," Proceedings of the Royal Society of London – Series A, Mathematical and Physical Sciences, vol. 303, pp. 193-205, February 1968.
- [38] Pacheco, J., et. al., "Assessing Liquid Droplet Erosion Potential in Centrifugal Compressor Impellers," *Proceedings of the Thirty-Eighth Turbomachinery Symposium*, Houston, TX, 2009.
- [39] Musgrove, G.O, Ransom, D.L., "Removal of Liquid from Airfoil of Equipment Have Gas-Liquid Flows," *US Patent Application 14/092976*, 2013.
- [40] Nelson, J.J., Alving, A.E., Joseph, D.D., "Boundary Layer Flow of Air over Water on a Flat Plate," *J. Fluid Mech*, 284, pp. 159-169, 1995.

ACKNOWLEDGEMENTS

The authors wish to thank GE Oil & Gas for their support and allowing the use of test data in this paper. The authors also thank David Ransom at Southwest Research Institute for supporting this paper.