



44TH TURBOMACHINERY & 31ST PUMP SYMPOSIA
HOUSTON, TEXAS | SEPTEMBER 14 - 17 2015
GEORGE R. BROWN CONVENTION CENTER

LUBRICATION DELIVERY ADVANCES FOR PUMPS AND MOTOR DRIVERS

Heinz P. Bloch

Professional Engineer
Process Machinery Consulting
Houston, TX and Westminster, CO



Heinz P. Bloch, P.E. holds a BSME and MSME (cum laude) degree. In a 53-year professional career devoted to machinery reliability improvement and maintenance cost avoidance, he authored or co-authored 19 books and over 620 articles or conference papers. He was one of the founding members of Texas A&M's PUMP USERS

SYMPOSIUM before retiring as Exxon Chemical's Company's Regional Machinery Network Specialist.

ABSTRACT

A ranking order is found in the Eschmann-Hasbargen-Weigand text "Ball and Roller Bearings" (ISBN 0-471-26283-8) for oil and grease-lubed bearings. The author re-assesses this ranking with input derived from the collective experience of a "Rotating Machinery Network." It is found that, unless plant-wide oil mist systems are justified, the listing in Table 1 is encouraging; it recommends oil-air for rolling element bearings. Details on all oil and grease application methods referenced in ISBN 0-471-26283-8 and ISBN 978-1-4822-2864-9 are explained.

Particular emphasis is given to (a) jet oil spray, (b) oil mist, now successfully used on approximately 26,000 electric motors and 130,000 process pumps world-wide, (c) shield orientation in typical grease-lubricated electric motor bearings and (d) good experience with PFPE-based (perfluoropolyether) greases in fully-sealed motor bearings. The PFPE experience completely up-ends prior notions regarding grease-filled (sealed) bearings.

INTRODUCTION

The substantive and authoritative text "Ball and Roller Bearings" (Ref. 1) recommended the relative rankings per Table 1 for general guidance. But Table 1 addressed bearings and lubrication applied in a very wide variety of machines, whereas this tutorial is making observation relating exclusively to process pumps and their electric motor drivers.

When published in 1985, Reference 1 represented a general consensus. Its relative accuracy has been reaffirmed and largely corroborated by an additional 30 years of experience.

We find it particularly reassuring that Reference 1 ranked circulating filtered oil and/or oil spray into the cages of rolling element bearings at the very top of the list. As of 2015, all world-scale manufacturers of rolling element bearings continue to support oil spray as their best lubricating choice. They note that, after first filtering, oil is sprayed at a precise rate needed for an oil film of proper thickness. No undue amounts of frictional energy are created and Reference 1 gave oil spray 10 out of 10 points. The tutorial information and guidance on these pages will revert back to these recommendations and will harmonize with the bearing manufacturers. In other words, it will answer the question "so what?"---a question of importance and interest to many conscientious reliability professionals.

The tutorial does not infringe on, or limit, the choices made by manufacturers and/or purchasers. All kinds of lubrication are presently available. However, the tutorial developer set out to address the needs of individuals and groups searching for better solutions. There are many ways to reduce pump bearing failure risks and frequencies; they are the subject of this presentation.

Table 1: Relative ranking of lube methods dating back to early 1980s (Ref. 1). Note Oil-Air and Oil Mist ranked near top

	Oil	Grease
Decreasing service life **	Rolling bearing alone	Rolling bearing alone
	Circulation with filter, automatic oiler	Automatic feed
	Oil-air Oil-mist	
	Circulation without filter*	
	Sump, regular renewal	Regular regreasing of cleaned bearing
		Regular grease replenishment
	Sump, occasional renewal	Occasional renewal
		Occasional replenishment
		Lubrication for-life

* By feed cones, bevel wheels, asymmetric rolling bearings.
** Condition: Lubricant service life < Fatigue life.
Source: Eschmann, Hasbargen and Weigand, *Ball and Roller Bearings*, John Wiley & Sons, Ltd., New York, 1985.



OIL VERSUS GREASE

The primary purpose of lubrication is to separate stationary from rotating parts by placing lubricant molecules between the components. A flow of lubricant also serves to carry away heat. Oil has advantages over grease because it removes more heat. Grease has an advantage because it is more easily confined. Both oil and grease can be applied in many different ways.

Grease is normally used in electric motor drivers ranging from fractional HP through approximately 500 kW; at over 500kW oil often represents an overall cost advantage. This is because grease can be readily introduced in the small-to-medium electric motor sizes where motor end caps readily accommodate grease.

With occasional exceptions, experienced petrochemical plants prefer oil over grease in one of its feasible application modes once 500 kW is exceeded. However, there are many different oil application details; likewise, there are many different grease application details. Each merits further elaboration and will be discussed later.

OIL LUBRICATION EXPERIENCE

Oil applied as a static sump is often called an “oil bath.” Static sumps--oil baths--are acceptable for relatively low bearing velocities. With a static sump, the oil level would be at or near the center of whichever rolling element passes through the 6 O’ clock (bottom) position. Oil bath lube is feasible for low-to-moderate shaft velocities. Once bearing elements plough through an oil bath at “high” velocities, heat generation will be of concern. Elevated bearing temperatures can degrade lubricant oxidation stability.

A widely used approximation suggests a “DN-value” (inches of shaft diameter multiplied by revolution per minute) of 6,000 as the threshold where bearing elements should no longer move through the oil bath and where, instead, lube oil is introduced into the bearings by other means. Traditionally, these other means have included oil rings (Figure 1), flinger discs (Figure 2), “jet oil spray” (Figure 3), and oil mist (Figure 4).

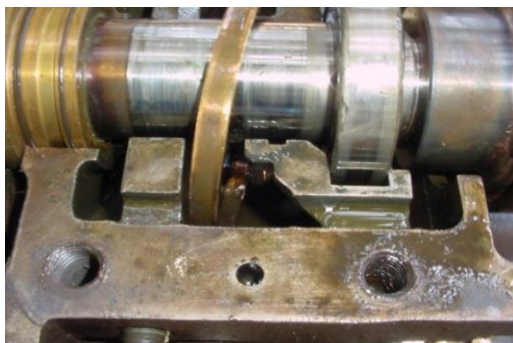

Figure 1: An unrestrained oil ring can touch portions of the inside of the bearing housings and suffer abrasive damage

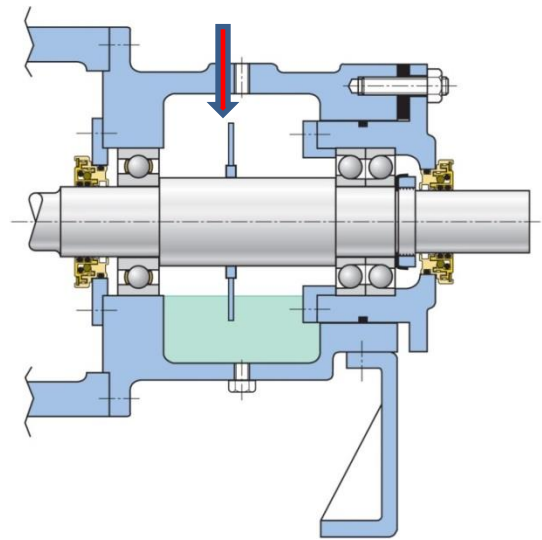

Figure 2: Flinger discs (arrow) avoid issues with oil rings; they can be accommodated in bearing housings fitted with cartridges designed to allow access and insertion

Flinger discs must be carefully engineered for the intended duty and must be securely fastened to shafts. Experienced European manufacturers often offer them as standard components. The discs allow moderate deviation from precise horizontality of shafts systems; they make contact with the oil level or are partially immersed in the bearing housing oil sump.

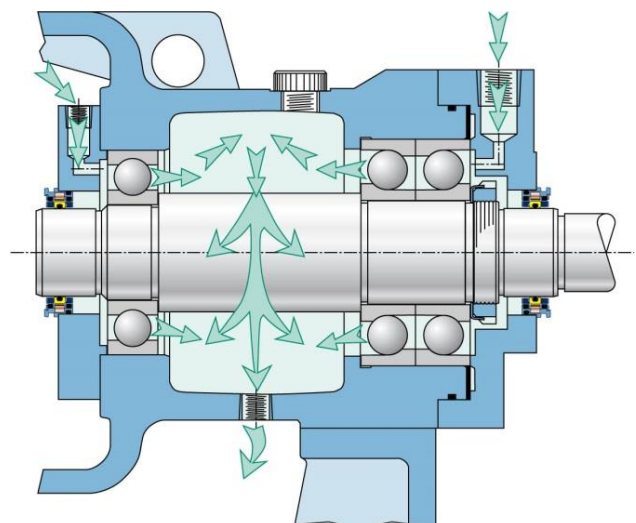

Figure 3: Oil spray (or, in similar fashion, an oil mist) directed into the bearing cage overcomes the “fan effect” (or windage) of inclined angular contact cages and provides an optimum thickness oil film for lubrication and heat removal at any bearing orientation

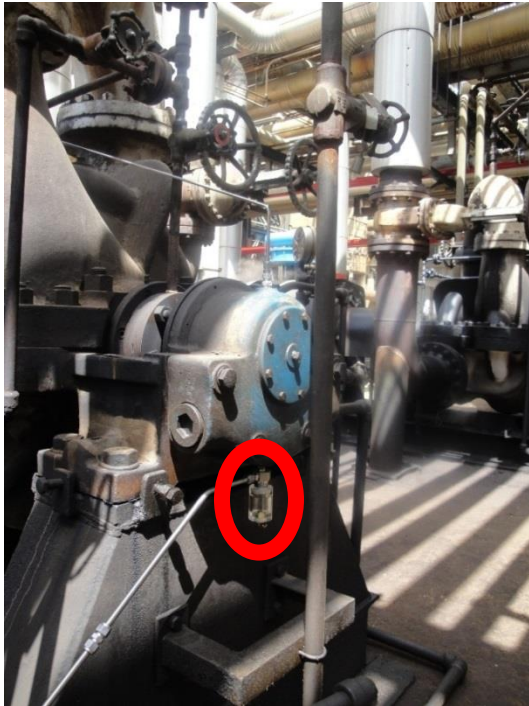

Figure 4: Pure oil mist on an API pump. A small transparent container (red circle) with vent tubing is located at the bottom

Oil mist is now used on ~130,000 process pumps and ~26,000 electric motors world-wide. API-610 gives application details very similar to Fig. 3, also Refs. 5 & 6. The key point is that oil mist is introduced between a long-life bearing housing protector seal (Figure 5) and a vent location. As the mist flows through the bearing and while shaft rotation creates turbulence, atomized oil globules combine and form larger oil droplets. The coalesced oil then coats and cools the bearing. Because the bearing housing is at slightly higher than atmospheric pressure, inward migration of atmospheric contaminants is avoided.

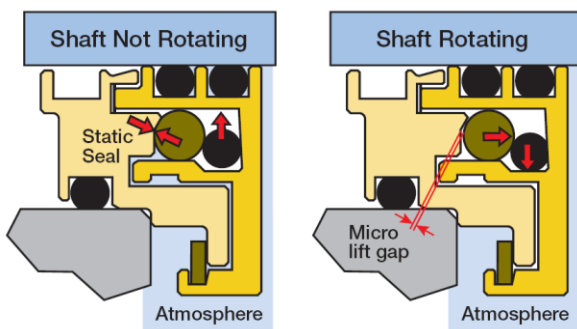

Figure 5: Bearing housing protector seal in stopped (left and operating (right) condition (Source: AESSEAL Inc.)

Constant Level Lubricators

Traditional lowest first-cost application of oil involves using one of many available constant level lubricators. Two widely used versions are shown in Figure 6. Side-mounted constant level lubricators or “oilers” are unidirectional. They should be mounted on the up-arrow side of the bearing housing.

Visualize, therefore, how air will be sucked in unless the lubricator is properly mounted, or how a small lowering of an oil level may deprive a bearing of lubrication. If the pressure in a closed bearing housing increases due to a slight temperature increase, pressure will cause the oil level to go down and oil will suddenly no longer flow into the bearing. Black oil will form and the bearing will start to fail. Pressure-balanced lubricators (Figure 7) are preferred over unbalanced types.

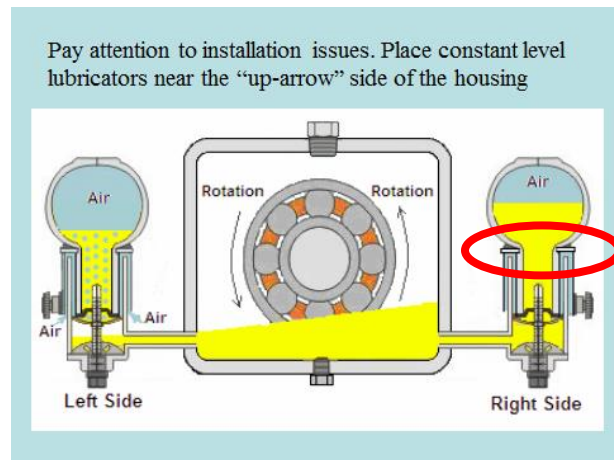

Figure 6: Traditional liquid oil application with static sump (oil bath). The lubricator on the left side should be removed

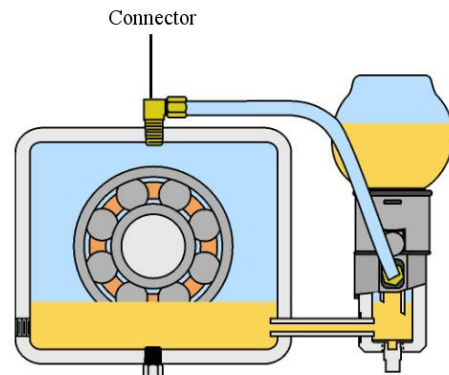

Figure 7: Constant level lubricator with pressure balance between bearing housing and lubricator body (TRICO Mfg.Co)

The red oval in Figure 6 points to caulking. Caulking has a finite life, requiring oilers to be replaced every few years.



VULNERABILITY OF OIL RINGS

Oil rings will work (Ref. 2); they are found in many machines. They have to be installed on a truly horizontal shaft system and are not allowed to make contact with housing-internal surfaces. Prevent them from wedging under the long limiter screw in Figure 8. Maintain depth of immersion and lube oil viscosity within acceptable ranges. Also, ascertain that bore eccentricity stays within the 0.002 or 0.003 inches recommended in Ref. 3.

Oil rings or no oil rings, problems result if oil can get trapped and overheated because no oil slot was provided. In Figure 8, only one oil return slot is shown (note below the radial bearing). And beware of adding just any bearing protector seal; doing so may result in somewhat higher pressure to the right of the thrust bearing compared to the pressure in the large, often well-vented, space near the center of the bearing housing.

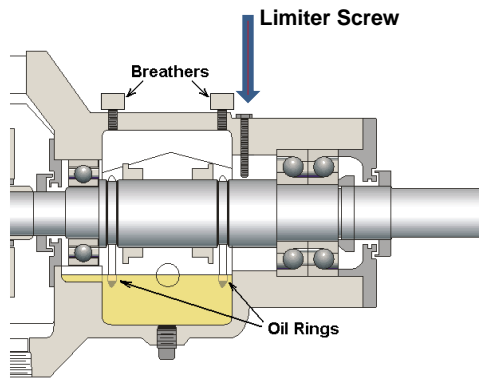

Figure 8: An oil return slot is (appropriately) shown below the radial bearing. But oil can get trapped, overheat and oxidize behind the thrust bearing unless an oil return slot is provided

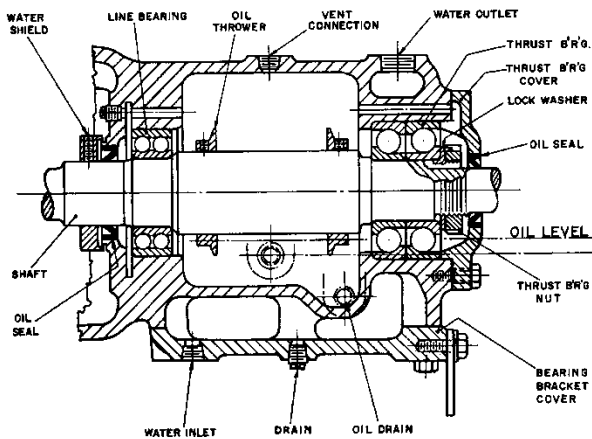

Figure 9: A Worthington Pump Company bearing housing from the 1960s. (Note pressure equalization holes surround bearings)

The prudent engineers at Igor Karrassik's Worthington Pump Company in the 1990s wisely placed a series of pressure equalization holes around each bearing (Figure 9). Without equalization, oil would often leak from under the lip seals. Yet, the "new" bearing housing of the late 1990s (Figure 10) does not show equalization holes. Sometimes these holes may not be needed. A problem occurs if they are needed and they are not there. You communicate with the manufacturer who thinks you must be doing something wrong. He asserts you're the first one to ever complain!

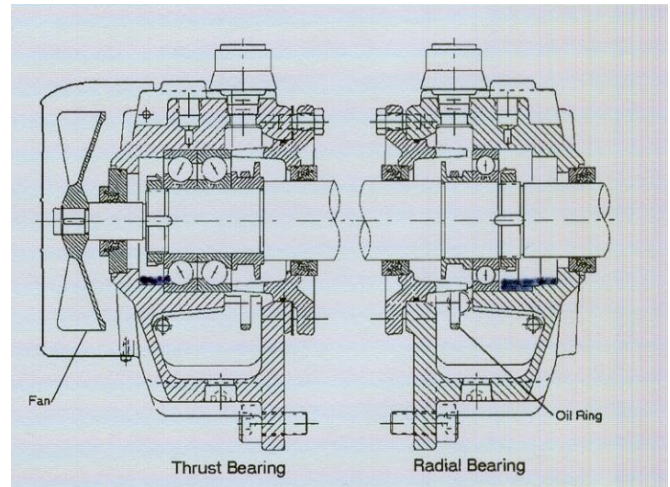

Figure 10: If oil is trapped behind bearings, it tends to overheat, oxidize and turn black (illustration from Ref. 2). While no oil equalization holes are shown, this vendor does provide them.

Oil Ring Cross-Section and Oil Gallery

In a series of rigorous tests, a pump manufacturer established that oil rings with cross-sections resembling the mirror-image trapezoids in Figure 11 may tolerate wave motion on seaborne vessels (Ref. 4). The trapezoidal oil rings were retained on contoured ring carriers and flung oil into oil galleries.

But, again, your pumps may incorporate the "flat" oil rings shown in Figures 1, 12, or 13. If you're happy with them, stay the course. If not, it's time to write better specifications and insist on specification compliance. Meanwhile, consider putting relevant details into your CMMS system. Measure and record the as-installed oil ring out-of-roundness when doing repairs. Measure oil ring width when next dismantling a pump in the shop. The difference between these measurements is evident to the naked eye, see Figure 14. This difference ended up as abrasion product and caused premature failure of the bearings.

Ask yourself: If a vendor offers new oil ring geometries, does this mean the old ones left something to be desired? If a vendor tests new oil rings for a few hours and finds no oil ring abrasion,



does that mean the test results can be extrapolated to a three-year run? Pumps on the vendor's test stand always start with fresh oil, but will your plant be on the same oil replacement schedule as the vendor's test stand? Rarely, if ever.

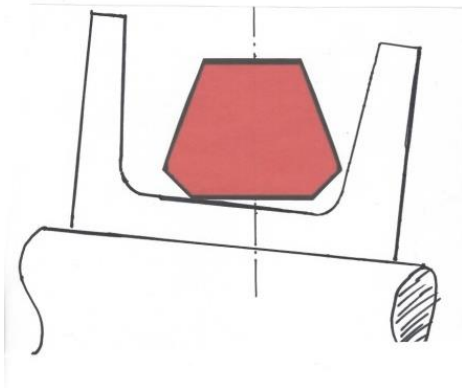

Figure 11: Mirror-image trapezoidal oil ring on a contoured carrier sleeve (Ref. 4)

These are among the questions for which competent reliability engineers seek answers. If no answers are found, the facility may find that random repeat failures occur from then on.

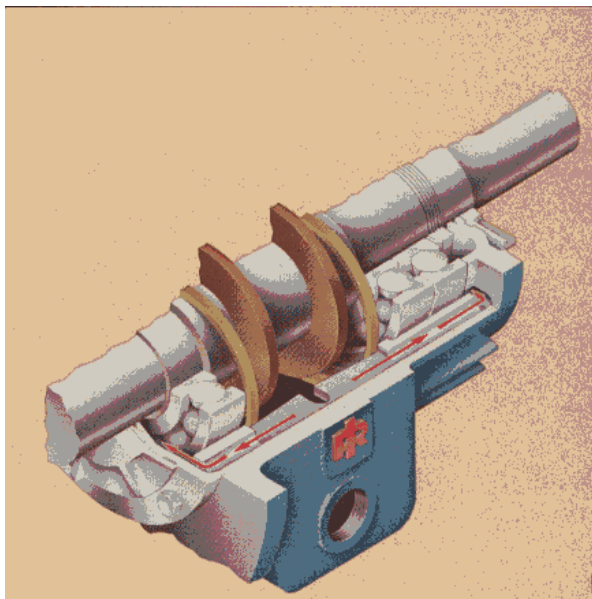
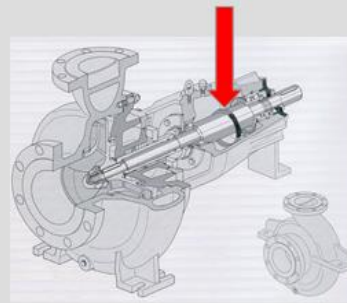

Figure 12: Two oil rings deposit oil in the slanted oil gallery of this Ingersoll-Rand pump bearing housing. Plastic discs limit oil ring travel. Note oil flow in gallery, red arrows

Not all pump models limit oil ring travel and, per TP30, rings may need special cross-section



- Better to have ring carrier
- Immersion-sensitive
- Ring explained at TAMU PUMP ("TP30") in 2014 had a very special trapezoid-shaped cross-section
- Plastic rings slip more than metal rings
- Could consider steel rings with diffusion-conversion coating

Figure 13: Many API-compliant pumps incorporate neither oil ring carriers nor oil galleries. The oil ring travel or skips around (Obtained from a manufacturer's marketing bulletin)

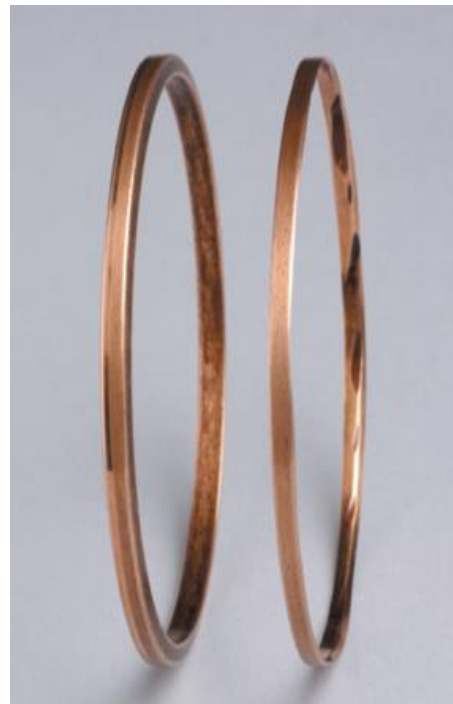

Figure 14: The wide oil ring on the left is new, the narrow oil ring on the right is badly worn. The difference between the two measurements is abraded material which contaminated the oil and caused premature bearing failure (Source: TRICO Mfg. Co)

GREASE LUBRICATION



There are isolated instances when bearings should be fully packed with grease. A boat trailer is such an isolated instance. As he backs the trailer onto the boat ramp and launches his small boat, its owner wishes to keep water away from the trailer's wheel bearings. When he tows the boat on a highway, the bearings rotate at usually no more than 900 rpm. We will assume that, on average, the owner tows the trailer 200 hours per year.

Compare this to the average electric motor bearing. Its shaft diameter is twice that of the boat trailer's axle. The electric motor bearing rotates at twice or four times the speed and we hope it lasts 24,000 hours--three or more years. That's why grease in electric motor bearings should take up only 30-40% of the space between bearing rolling elements. Packing the bearing full of grease would create excess heat and reduce bearing life.

Lubrication Charts

Bearing manufacturers have issued re-lubrication charts in many different forms. On the one shown in Figure 15, a particular bearing style is indicated by the letter "C" on top of the vertical grid axis. Depending on shaft size and speed the recommended intervals can be read off on the vertical axis as hours between re-lubrication. While these intervals were conservative and pertained to standard greases, Figure 15 was often used to envision where the use of life-time lubrication (meaning fully sealed, non-regreasable bearings) should be discouraged. If a bearing cannot be re-greased (and sealed bearings cannot be

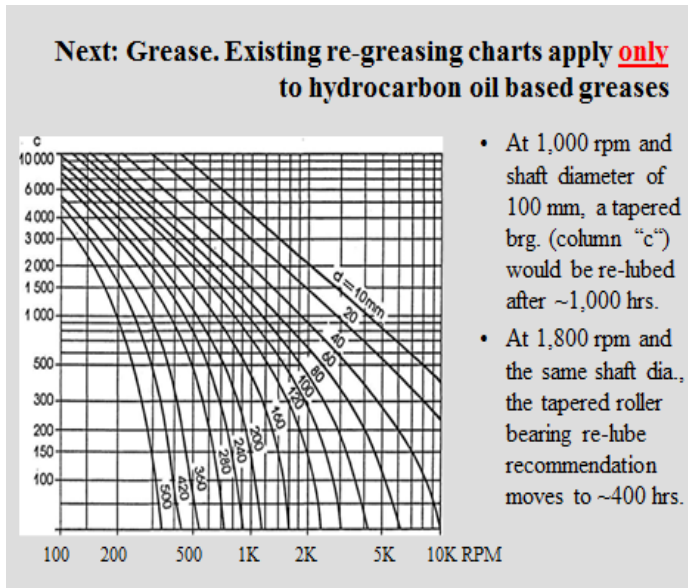

Figure 15: Bearing re-lubrication chart intended for a particular bearing style (e.g. tapered roller bearing) as a function of shaft speed and shaft size (Source: SKF America)

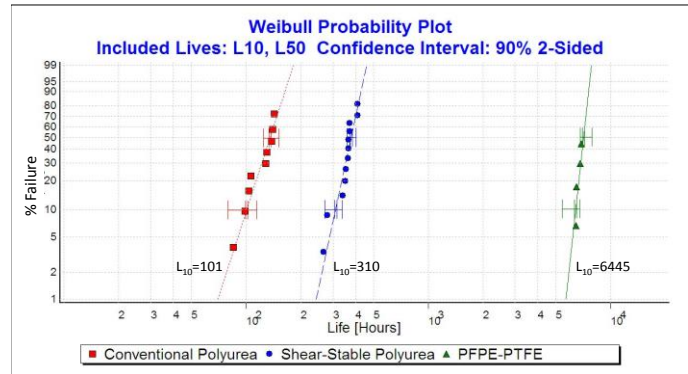

Figure 16: Weibull probability plot for modern PFPE-PTFE grease formulations

re-greased), the indicated interval will at least provide a general guide on expected bearing life. The advent of entirely different non-hydrocarbon greases means that Figure 15 will have to be modified for PFPE-PTFE greases (Figure 16).

PFPE (perfluoropolyether) greases present an interesting lubrication alternative which was studied and fully validated at smaller and/or non-HPI facilities in recent years. It was found that developments in grease technology can greatly extend the life of sealed bearings.

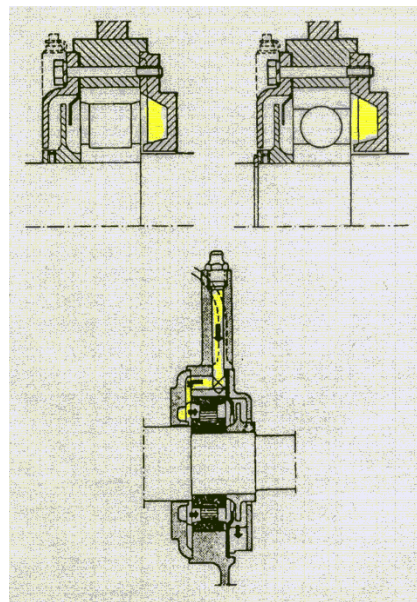

Figure 17: Through-path, unshielded, self-relief bearings application range traditionally associated with "life-time" lubrication in electric motor bearings.



In one study case, traditional motor bearings were supplied with sealed-in PFPE grease of the proper consistency (its PTFE ingredient is more commonly known as Teflon®) and the resulting life extensions tracked and explained on a comparison plot (Figure 16). This detailed cost study (at a Canadian paper mill) showed benefits over periodic regreasing in certain industries and environments.

However, the experience with PFPE-PTFE may not apply to every situation and careful follow-up is always recommended. Also, these greases cannot be mixed with even trace quantities of traditional grease types.

Shields versus no Shields in Electric Motor Bearings

Through-path, unshielded, self-relieving bearings are shown in Figure 17. Here, the motor manufacturer and designer ascertain that over-greasing is simply not possible; excess grease flows into a spent grease cavity or to the atmosphere. No shields are used in these bearings.

Chances are the through-flow design in Figure 18 saves pennies over Figure 17; however, spent grease will be expelled only if the drain plug is first removed from the bearing housing. The human elements of (a) training and (b) conscientiously carrying out proper work procedures are then getting very important.

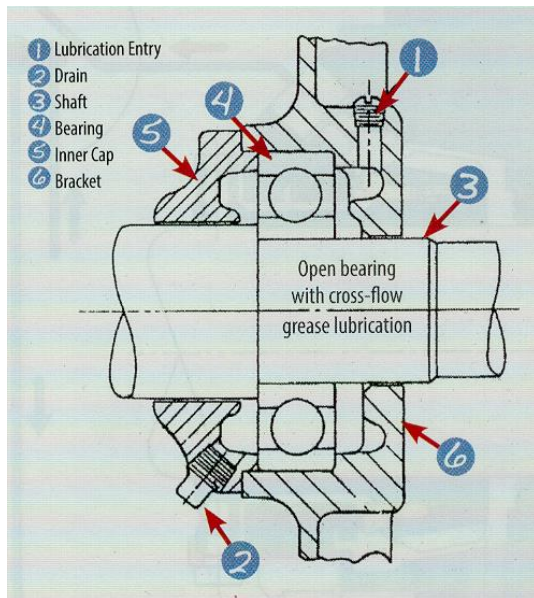

Figure 18: Through-flow grease; the drain plug must be removed during re-greasing

Instead of through-flow, shielded bearings were soon adopted; a single shield is shown in Figure 19 and the grease reservoir is adjacent to the shield. There is an annular gap of between 0.05

and 0.10 mm (radial measurement) between the shaft surface and the shield's inner diameter. The design intent is for a small amount of oil to migrate from the grease reservoir into the bearing by capillary action. Grease replenishment would require removal of the drain plug and orienting the shield as shown here would prevent packing the bearing with grease.

But design intent is one thing and field action is quite another. Inadequate training or personnel hoping to take shortcuts have often left drain plugs in place. In that case, excessive grease gun pressures forced shields into rubbing and scraping contact with rolling elements upon which bearing failure is inevitable.

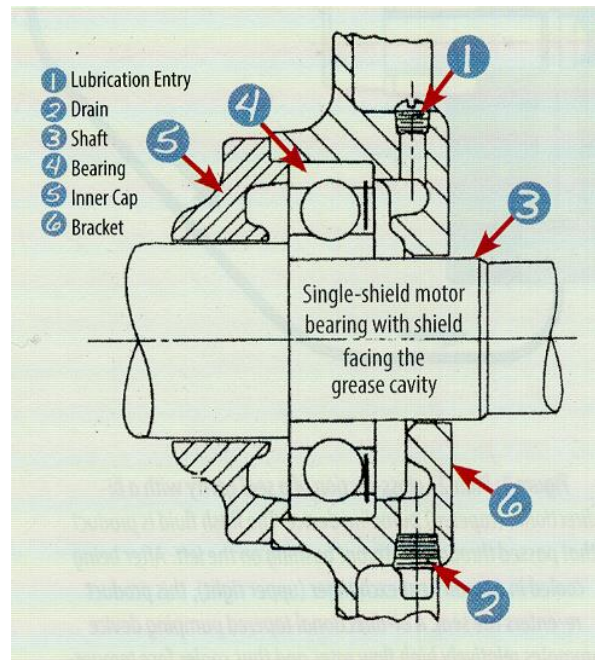

Figure 19: Single-shielded bearing with removable plug (2)

Double-shielded bearings (Figure 20) at least eliminated questions as to which side should face the reservoir, but leaving drain plugs in place still killed bearings. Industry virtually forgot that all we're asking for is to put a new charge of unpressurized grease into the reservoir every few years and to then let capillary action slowly move exceedingly small quantities of oil into the ball path. Reliance Electric added a metering plate (red part, Figure 21) in a valiant effort to ward off the over-greasing calamity. The results were mixed; mechanics often took one look at metering plates and threw them away.

ARCO Alaska mitigated over-pressuring with a drain pipe, Figure 22, left open on purpose. A small volume of spent grease formed a "natural plug." The plug advances each time new grease is added to the reservoir. Again, we will spare the reader a description of what a heap of grease looks like when it is



expelled onto the pump base. After a year or so it's more than just a housekeeping problem.

Alternatively, we might try accountability and insist on staffers following instructions. We found out how well this admirable approach worked in the United Arab Emirates where a large refinery reported replacing 7 bearings per 1,000 electric motors per year. When asked what magic grease formulation they were

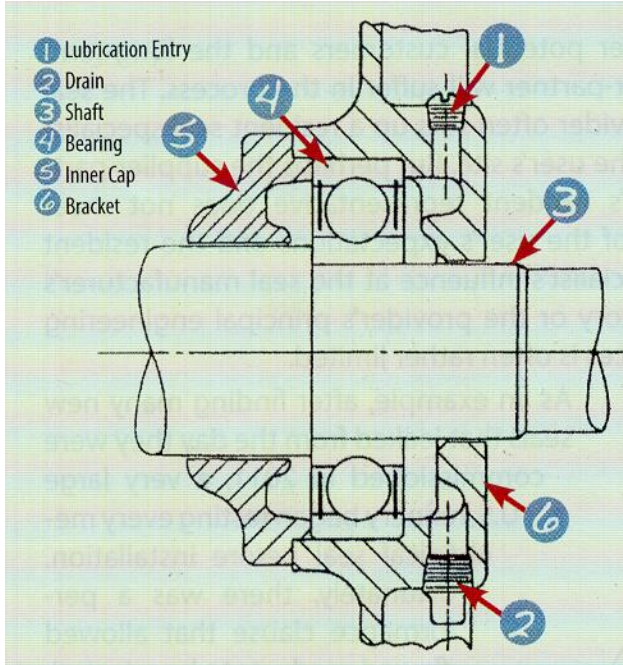

Figure 20: Double-shielded bearings are sometimes used because their symmetry allows installation in either direction

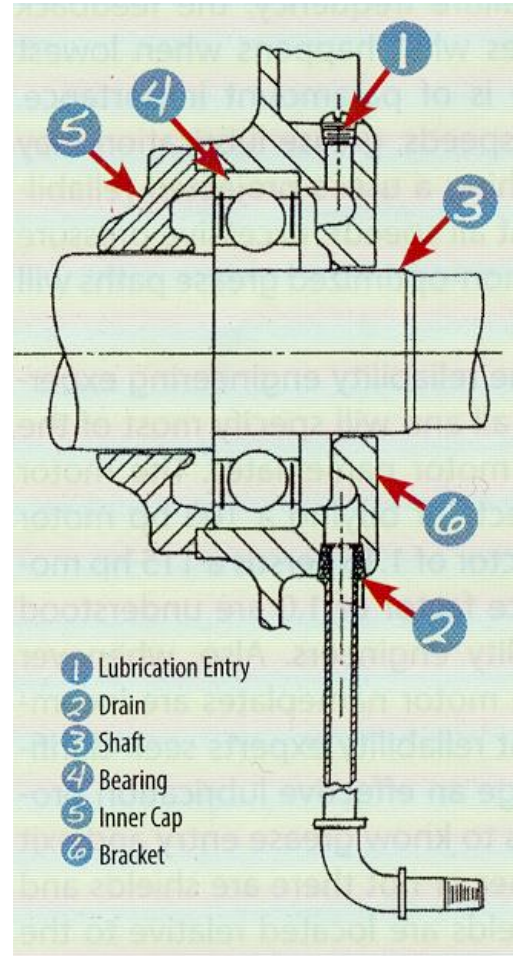

Figure 22: Permanent drain opening prevents over-pressuring

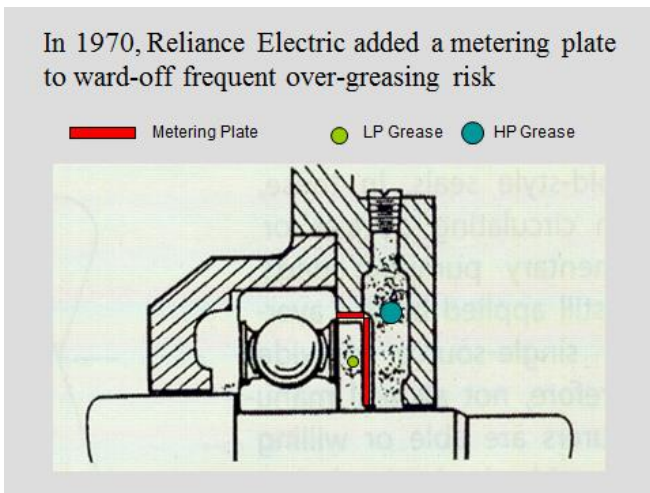

Figure 21: Metering plate as a first line of defense against over-pressuring the grease (Reliance Electric, ~ 1970)

Still, Figure 22 shows the best solution from technical acceptability and "not wanting to argue with my workers" points of view.

using, a senior manager explained that his workers simply followed instructions and that grease-related bearing failures are a rarity. In other words, they know what bearings they have, they remove drain plugs, they re-grease with the prescribed amount of grease, then move on to do the next electric motor. After allowing two to three hours for grease to settle, a worker returns and re-inserts each drain plug.

This simply illustrates that there is no substitute for following a proper work execution procedure. Good supervision and management prevent failures and generate higher profits.



RANKINGS

Some rankings are subjective, and our rankings are among them. The author was asked to provide data wherever possible and that request is commendable. But nobody has data on how many oil rings will malfunction because the maintenance person did not install it right, or the pump design allows the oil ring to slosh around, or because the pump manufacturer supplied oil rings that have not been stress-relief annealed and which, for that reason, lose roundness over time. About the last thing a pump manufacturer would ever want us to know is how many black oil incidents are caused by designs that overlook the need to provide an escape path for small amounts of oil trapped behind bearings (Figure 10) or for not seeing to it that there is pressure equalization between the space to the left and right of any particular rolling element bearing. We refer back to Figure 9 or, in the case of grease, the vulnerabilities of Figures 19 and several others if drain plugs are left in place.

Except for a rather expensive traditional auxiliary lube pump-around system with reservoir, an integrated lube spray system (Figure 23, right side) is the best of all worlds. One would no longer worry about oil rings and their many demonstrated flaws, constant level lubricators, installation accuracy, shaft inclination, and so forth. Sooner or later an innovative pump manufacturer will offer a pumping device (Figure 23, item "P") and filter (F) which will satisfy many thousands of buyers. The process pump manufacturers unwilling or unable to supply oil spray might console themselves with purchasers who buy only from the lowest initial bidder, or sellers of spare parts and maintenance services. It's a free choice we can all make. Yet, responsible buyers favor sellers who add value, not uncertainty.

Years of obtaining and examining proprietary data from my machinery network colleagues (with access to at least 24,000 pump sets) and decades of observing elusive repeat failures now lead me to suggest a new ranking for the reader's consideration:

OIL LUBRICATION

- Oil spray, filtered/pressurized. Also oil mist/coalesced oil coats bearing [*Highest*] = 10
- Circulation, filtered/pressurized = 9
- Quiescent sump, w/debris not stirred up = 6
- Sump, with slinger disc [*Average Rank*] = 5
- Sump and guided oil rings, well within concentricity spec = 4
- Sump and non-guided oil rings well within conc. spec = 3
- Sump and non-guided oil rings out-of concentricity [*Lowest Rank*] = 2

GREASE LUBRICATION

- Life-time PFPE-PTFE [*Highest Rank*] = 7
- Through-flow, low pressure = 6
- Random-flow, low pressure = 4
- Life-time EM polyurea = 3
- Random-flow, random press. = 2
- Random-flow, over-pressured [*Lowest*] = 1

Putting it another way: Decades of field observation must be weighed against manufacturers' test cycles of, typically, a few hours. Factory test durations lasting from 2-8 hours were reported by one major pump manufacturer in 2000. It appears they became the basis of advocating plastic oil rings and marginally thicker oils. However, these changes did not cure the problem of black oil experienced by a disappointed customer,

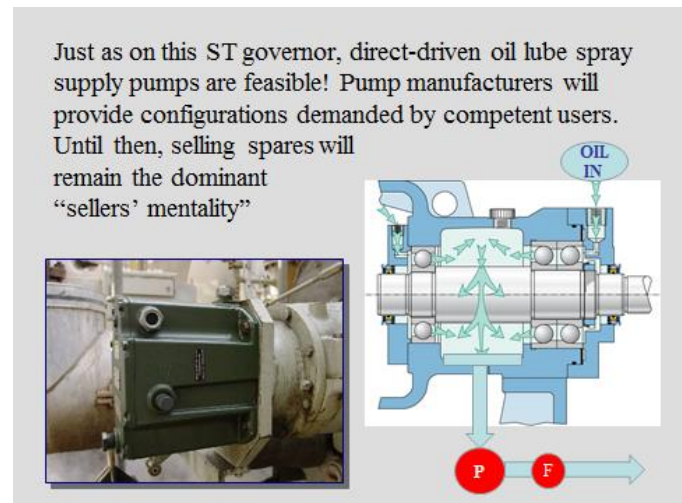

Figure 23: Like traditional auxiliary pump-around lube systems, lube spray systems (right side) are ranked best of all worlds. A shaft-drive steam turbine governor (left) demonstrates one of numerous spray pump drive options (Refs. 5 through 7).

a user company in Canada. Likewise, follow-up talks led nowhere; they left attendees of certain discussion group sessions at a major pump conference with considerable frustration.

Needless to say, the machines on a pump manufacturer's test stand are properly aligned and the lubricant is fresh and clean. In contrast, the degree of inaccuracy encountered in many field environments differs greatly from the accuracy found on test stands. Neither the training nor the abilities of crafts and service



personnel will always measure up to expectations. In some installations the piping connected to pumps is pushing and pulling. As a result, bearings are edge-loaded and the oil film can no longer provide adequate separation of parts (Ref. 6).

Shaft alignment is achieved by putting shims under equipment feet which, as a logical consequence, tends to cause shaft systems to be at a slight angle relative to the true horizon. On shipboard, pumps pitch and roll. Equipment surveillance and precautionary oil changes differ on shipboard from what we find at many land-based installations.

These and other experience factors interact; they admittedly shape and skew rankings in the eyes of field-experienced individuals. Their backgrounds differ, their perceptions differ, and we must leave it to our readers and/or our tutorial attendees to judge where to place their trust. We have observed that many process pumps in industry are experiencing repeat failures even as you read this narrative or attend this tutorial session.

The author does not believe that a reasonable person needs to show data to prove that driving automobiles with worn tires is a greater risk than driving on tires with tread. Also, what looks worn to "A" looks normal to "B." It is no different with oil rings in pumps at location "X" versus location "Y." Gravity being gravity, the sketch in Figure 11 is a scientific fact. The ultimate ramifications of a trapezoidal oil ring operating in this manner can be foreseen: A trapezoidal oil ring has two "pointed" or "circumferential" ridges—one on the left and one on the right side. Pointed ridges have a very small total surface area. As the oil ring slews from side-to-side in its carrier sleeve, it will touch the side of the carrier sleeve. That means the force-per-unit-area, the "pounds-per-square-inch" (commonly known as "pressure" will be rather high. When that happens, the "pointed ridge" will break through the oil film and abrasion will occur.

Whenever a pointed ridge breaks through the oil film, there will be increased friction and the oil ring will slow down. Long-term satisfactory operation will be at risk, unless the pump owners invest heavily in preventive maintenance action. But preventive maintenance costs money, and that is simply an additional reason why oil rings rank very low on our scale.

Reviewers have asked for more detail on oil-air, also called "jet oil lubrication", Figures 23 and 24 (Ref. 7). Jet oil lube represents the highest-rated application method. Envision, therefore, how jet oil---widely used in aerospace over the past 70 years--- will open a window of opportunity for reliability-focused users and/or innovative pump manufacturers. Think of a small oil pump ("P", Figure 23), either internal to the process pump bearing housing or incorporated in a small assembly screwed into the bottom drain of your present process pump. This upgrade can provide filtration, metered flow, and proper pressure downstream of the oil sump and upstream of the spray nozzles. Motivated users have written this preferred lube

application approach into their pump specifications and are actively pursuing this pump reliability enhancement.

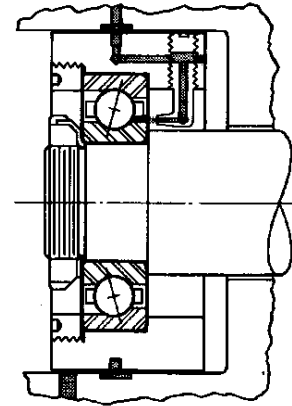

Figure 24: Jet-oil lubrication (Ref. 7), whereby liquid oil is sprayed directly into the rolling elements of a bearing

Finally, and by way of simple reaffirmation and reassurance: What you presently *have* in your pumps and electric motors will work. Still, what you *could have* in your pumps would work better and more reliably. We just thought we might bring it to the attention of those wishing to add value to their enterprise.

NOMENCLATURE

D = shaft diameter, inches HP = horsepower
N = rpm = revolutions per minute
CMMS = Computerized Maintenance Management System

REFERENCES

1. Eschmann, Hasbargen, Weigand "Ball and Roller Bearings," (1985) John Wiley & Sons, Hoboken, NJ
2. Bradshaw et al., Proceedings of the 17th TAMU International Pump User's Symposium, (2000)
3. Wilcock, Donald F., and Booser, E.R., "Bearing Design and Application," (1957), McGraw-Hill Company, New York, NY
4. Bradshaw et al., Proceedings of the 30th TAMU International Pump User's Symposium, (2014)
5. Bloch, H.P., and Budris, A.R., "Pump User's Handbook: Life Extension, 4th Ed., (2014) Fairmont Press, Lilburn, GA, ISBN 0-88173-720-8
6. Bloch, H.P., "Pump Wisdom: Problem Solving for Operators and Specialists," (2011) Wiley&Sons, Hoboken, NJ, ISBN 978-1-118-04123-9
7. MRC "Engineer's Handbook," General Catalog 60, Copyright TRW, 1982