

THE IMPACT OF CAPITAL ADEQUACY RATIO (CAR), NET INTEREST MARGIN (NIM), LOAN TO DEPOSIT RATIO (LDR), AND COST TO INCOME RATIO (CIR) TOWARD BANKS PROFITABILITY (Comparison Study of Domestic Bank and Foreign Bank in Indonesia from 2011 to 2015)

Amelia Jovita, Sugeng Wahyudi, Ahyar Yuniawan

ABSTRACT

The purpose of this research is to analyze Capital Adequacy Ratio (CAR), Net Interest Margin (NIM), Loan to Deposit Ratio (LDR), Cost to Income Ratio (CIR) toward Return On Asset (ROA) of Domestic Banks and Foreign Banks in Indonesia from 2011 to 2015.

The population of this research is all domestic banks and foreign banks in Indonesia that operate from 2011 to 2015. This research uses purposive sampling method as sampling technique, therefore total samples of this research is 92 domestic banks and 10 foreign banks. The analysis technique that is used in this research is multiple linear regression analysis. This research also uses Chow test to compare the influence of CAR, NIM, LDR, CIR toward ROA between domestic banks and foreign banks.

The result of analysis shows that CAR, NIM, LDR, and CIR have significant influence toward ROA in domestic banks. Meanwhile, only CAR and CIR in foreign banks show significant influence toward ROA. Chow test result shows that there is different influence of CAR, NIM, LDR, CIR toward ROA between domestic banks and foreign banks.

Keyword : *Bank performance, Domestic Bank, Foreign Bank, Return On Asset (ROA), Capital Adequacy Ratio (CAR), Net Interest Margin (NIM), Loan to Deposit Ratio (LDR), Cost to Income Ratio (CIR).*

1. INTRODUCTION

Banks hold a vital role in the Indonesia's economic condition. One of the most important role is the function as financial intermediary, such as function as broker, function as asset transformers, role as delegated monitor, and role as information producer. Therefore, the sustainable function as financial intermediary should bring profitability to the banks. Besides, the banks have to apply prudential principles because they have major responsibilities to manage funds from depositors and lend the funds to the borrowers.

The financial performance of banks has critical implication for Indonesia's economic growth. Good banks' performance generates more profit to shareholders and it can stimulate to increase the additional investment and give positive reaction to the economic growth. But, poor banks' performance can lead to banking failure and economic crisis which have negative effect to the economic growth (Ongore & Kusa, 2013).

The banking industry in Indonesia includes domestic banks and foreign banks where domestic banks consist of state-owned banks, national private

foreign exchange banks, non-foreign national private banks, regional development banks, and mixed banks. While foreign banks are the branch offices of foreign banks in Indonesia. This study uses domestic banks and foreign banks as the object of research because there are differences in terms of ownership (domestic and foreign) but competing to gain market share in Indonesia. Domestic banks are banks whose majority ownership is owned by the central government while foreign banks are banks owned by foreign investors (Kasmir, 2005). Domestic banks and foreign banks can be compared equally, because based on Bank Indonesia regulation; there is no different treatment between foreign banks and domestic banks. The differences between domestic banks and foreign banks are capital owner and the form of legal entity (Hadad *et al.*, 2004).

Financial profitability ratio that has been use in banking industry are Return On Equity (ROE) and Return On Asset (ROA). ROA focuses on the company's ability to earn profit in its operations, while ROE only measures the earning that has been earned by the investors. So the profitability ratio that is being used in this research is ROA. ROA is one of the important ratios to show the profitability of a bank, which is the ratio of earnings to total assets. ROA measures the ability of bank management to generate profits by utilizing the company's assets. In other words, ROA shows how efficiently the company's resources are used to generate revenue. It further demonstrates the efficiency of corporate management in generating net income from all resources of the institution (Sudiyatno & Suroso, 2010).

According to Bank Indonesia Regulation Number 13/1 / PBI / 2011 related to Commercial Bank Soundness Rating which banks are required to conduct self-assessment using Risk-based Bank Rating (RBBR) either individually or On a consolidated basis, with scope of assessment covering the following factors: Risk profile, Good Corporate Governance (GCG), Profitability (earnings); And Capital (capital) to produce Bank Composite Rating of Bank Soundness. So this research is using the ratio of Capital Adequacy Ratio (CAR), Net Interest Margin (NIM), Cost to Income Ratio (CIR), and Loan to Deposit Ratio (LDR) to assess the financial performance of banks.

In 2011 – 2015, ROA of banks in Indonesia has decreasing pattern, so the further analysis is needed on this matter related to financial ratios affecting ROA. In this research there will be comparison between the financial ratios affecting ROA domestic banks and foreign banks. The past performance of domestic banks and foreign banks from year 2011 to 2015 can be observed from the changes in the tables below and we can find phenomenon gaps are occurring due to inconsistent data from CAR, NIM, LDR, CIR, and ROA that show inconsistent fluctuations.

Table 1. The Average of ROA, CAR, NIM, LDR, and CIR of Domestic Banks

Period	CAR (%)	NIM (%)	LDR (%)	CIR (%)	ROA (%)
2011	22.08	6.57	82.53	80.79	2.32
2012	20.78	6.28	86.07	79.07	2.29
2013	21.80	6.40	94.57	79.46	2.32
2014	20.06	6.09	92.85	82.54	2.00
2015	20.02	5.94	86.89	85.18	1.72

Table 2. The Average of ROA, CAR, NIM, LDR, and CIR of Foreign Banks

Period	CAR (%)	NIM (%)	LDR (%)	CIR (%)	ROA (%)
2011	33.23	3.23	136.32	70.05	3.05
2012	34.51	2.82	147.34	76.18	2.53
2013	41.04	3.09	167.31	77.46	2.53
2014	42.56	3.76	152.59	72.49	2.86
2015	44.06	3.92	129.31	84.84	1.79

According to Table 1, CAR, NIM, LDR of domestic banks are in line with the ROA of domestic banks in 2011-2015, except for LDR in 2011 – 2012. The positive effects of CAR, NIM, and LDR toward ROA in the domestic banks will be analyzed further in this research. CIR of domestic banks has inverse relationship with ROA of domestic banks in 2013 – 2015. However, CIR is in line with the ROA of domestic banks in 2011 - 2013. The inconsistent data fluctuations show phenomenon gaps in domestic banks' performance, so the further research is needed.

According to Table 2, CAR of foreign banks increases year to year but ROA of foreign banks fluctuates in 2011 – 2015. In 2011 – 2012 and 2013-2014, NIM and ROA of foreign banks have in-line movement, but NIM has inverse relationship with ROA of foreign banks in 2012-2013 and 2014-2015. In 2011 – 2013, LDR has inverse relationship with ROA of foreign banks, but in 2014 – 2015, LDR is in line with ROA of foreign banks. The positive effects of CAR, NIM, and LDR toward ROA in the foreign banks will be analyzed further in this research. In this period, CIR of foreign banks has inverse relationship with ROA of foreign banks. The negative effect of CIR toward the ROA in the foreign banks will be analyzed further in this research. This inconsistency of data fluctuations show phenomenon gaps in foreign banks' performance and therefore, further research is required.

Based on previous researches, there are some gaps in the impact of CAR, NIM, LDR, and CIR toward ROA. According to research done by Irmawati & Lestari (2014), Mayes & Stremmel (2012), Rahman *et al* (2015), Ongore & Kusa (2013), CAR has positive and significant impact on ROA. On the opposite to this, based on research done by Putranto *et al*. (2014), Jha & Hui (2012), Azam & Siddiqui (2012), CAR has negative and significant impact on ROA. And based on Jumono *et al* (2015), research shows that CAR has insignificant impact to ROA.

According to research done by Hutagalung *et al.* (2013), Azam & Siddiqui (2012), Raharjo, *et al* (2014), NIM has positive and significant impact on ROA. Otherwise, Jha & Hui (2012) research shows that NIM has negative and significant impact on ROA. Based on Boehmer & Ljungvist (2004) research, shows that NIM has insignificant impact to ROA.

Based on Maharani & Sugiharto (2007), Rengasamy (2014) researches shows that LDR has positive and significant impact on ROA. On the contrary Gelos (2006) research shows that LDR has negative and significant impact on ROA. According to Jumono *et al* (2015) research, shows that LDR has insignificant impact to ROA.

According to research done by Irmawati & Dewi Lestari (2014), CIR has positive and significant impact on ROA. But based on Sudiyatno & Suroso (2010), Azam & Siddiqui (2012), Rachdi (2013), Almazari (2014) researches, CIR has negative and significant impact on ROA. Ariyanto (2004) research shows that CIR has insignificant impact to ROA.

On the Table 1 and Table 2, the ROA of domestic and foreign banks have declining trends, which means the profitability of banks are decreased that can give a major impact to the banks performance. Moreover, there are research gaps and phenomenon gaps occurring in this research, therefore the research questions are:

- 1.a. Does Capital Adequacy Ratio (CAR) have a positive impact on the profitability (ROA) of domestic banks?
- 1.b. Does Capital Adequacy Ratio (CAR) have a positive impact on the profitability (ROA) of foreign banks?
- 2.a. Does Net Interest Margin (NIM) have a positive impact on the profitability (ROA) of domestic banks?
- 2.b. Does Net Interest Margin (NIM) have a positive impact on the profitability (ROA) of foreign banks?
- 3.a. Does the Loan to Deposit Ratio (LDR) have a positive impact on the profitability (ROA) of domestic banks?
- 3.b. Does the Loan to Deposit Ratio (LDR) have a positive impact on the profitability (ROA) of foreign banks?
- 4.a. Does Cost to Income Ratio (CIR) have a positive impact on the profitability (ROA) of domestic banks?
- 4.b. Does Cost to Income Ratio (CIR) have a positive impact on the profitability (ROA) of foreign banks?
5. Is there any difference between the impact of CAR, NIM, LDR, and CIR on domestic banks and foreign banks profitability (ROA)?

2. LITERATUR REVIEW

2.1 Theory

The Trade-off theory of capital structure refers to the idea that a company chooses how much debt finance and how much equity finance to use by balancing the costs and benefits. Trade-off theory of capital structure basically entails offsetting the costs of debt against the benefits of debt. Trade-off theory of capital structure primarily deals with the two concepts – cost of financial distress and

agency costs. An important purpose of the trade-off theory of capital structure is to explain the fact that corporations usually are financed partly with debt and partly with equity (Myers, 2001).

Based on a markup theory of bank loan rates (Rousseas, 1985), interest rate on bank loans is to be seen as the “price” of financial “goods” provided by financial industry. In raising funds, banks compete in wholesale financial markets, while banks determine the price of credit as a retail market. Banks have the ability as a price setter by determining the size of the desired mark up in pricing on credit. The amount of markup will determine the achievement of banks’ profit target (Koch, 1997).

The efficiency hypothesis emphasizes the efficiency of operations that can decrease the average cost due to increase output. Several studies have found that efficiency is the dominant variable explaining in bank profitability (Subandi & Ghozali, 2013).

Liquidity theory is the ability of a company to fulfill its short-term obligations to make some cash (and cash equivalents, such as current or other deposits at a bank that can be withdrawn at any time) owned by the company. The higher liquidity indicates the company's cash capability to pay its short-term liabilities (Brigham & Gapenski, 1996).

Return on Asset (ROA) is a profitability ratio that can be used to measure the effectiveness of the company to generate profits by utilizing its total assets. Bank with higher ROA shows better financial performance. The increase of ROA can generate the increase of banks’ profitability, besides the profitability for the shareholders can also increase (Husnan, 1998). ROA is calculated based on the ratio of earnings before tax with the average total assets with the best standard of 1.5 %.

According to Lukman Dendawijaya (2005), Capital Adequacy Ratio (CAR) is a ratio used to measure a bank's capital adequacy to cover all the potential inherent risk in the bank earning assets, mostly in the form of loans. CAR based on the principle that any assets owned by the bank carries the risk that banks should provide capital for a certain percentage of total earning assets. In accordance with the conditions set by Bank Indonesia to adopt international banking regulations relating to minimum capital adequacy (*Basel Capital Accord*) set by the Basel Committee on Banking Supervision, currently all commercial banks in Indonesia have to have minimum capital of at least 8 % of total risk-weighted assets (risk weighted assets) (PBI, 2013).

Net Interest Margin (NIM) reflects market risks arising from the movement of market variables, which may harm banks. Based on Bank Indonesia regulation, one proxy of market risk is the interest rate, measured from the difference between interest income received from bank loans and other earning assets at a given time period reduced by the amount of interest paid to depositors and holders of bank debt divided by the average number of earning assets in the same time period (Mawardi, 2005). NIM will affect the bank's profit and loss which ultimately affects the bank's performance (Hutagalung et al., 2012). A healthy bank has NIM above 2% (Muljono, 1999).

Loan to Deposit Ratio (LDR) is a ratio that measures bank liquidity in meeting the funds withdrawn by the public in the form of savings, time deposits, and demand deposits. LDR is a commonly used statistic for assessing a bank's liquidity by dividing the bank's total loans by its total deposits. The risk of withdrawing funds for each liquidity varies (Cashmere, 2012).

Based on Bank Indonesia Regulation, a healthy bank should have LDR in the range of 78% to 92%. Bank Indonesia needs to establish the LDR range because besides it can affect bank liquidity. LDR is also an indicator that can perform its function as financial intermediary (Peraturan Bank Indonesia, 2013).

Cost to Income Ratio (CIR) can be called as the efficiency ratio used to measure the bank's management capability in controlling operating costs against operating income. This ratio shows how efficiently the bank is being run, the lower the ratio, the more profitable the bank (Almilia and Herdiningtyas, 2005). Based on Bank Indonesia regulation, the maximum percentage of CIR is 90%. The higher the ratio of CIR means the more inefficient the operating costs, therefore bank has smaller possibility to earn profit (Sudiyatno & Fatmawati, 2013).

2.2 Previous Research

Esther Novelina Hutagalung, Djumahir & Kusuma Ratnawati (2013) examines the analysis of financial ratios on the performance of commercial banks in Indonesia. The study was conducted on ROA, CAR, NPL, NIM, CIR, and LDR variables. Technical analysis used is regression analysis. The results showed that CAR and LDR had negative and insignificant effect on ROA. NPL and CIR have a negative and significant effect on ROA. NIM has a positive and significant effect on ROA.

Bambang Sudiyatno & Jati Suroso (2010) studied the analysis of influence of third party funds, CIR, CAR, and LDR on Financial Performance in public banking sector at Indonesia Stock Exchange (Period 2005 - 2008). The study was conducted on variable ROA, third party funds, CIR, CAR, and LDR. Technical analysis used is regression analysis. The results showed that third party funds (DPK) and CAR have positive and significant effect on ROA. CIR have a negative and significant effect on ROA. LDR has positive and insignificant effect on ROA.

Kartika Wahyu Sukarno, and Muhamad Syaichu (2006) examines the analysis of factors affecting the performance of commercial banks in Indonesia. The research was conducted on ROA, CAR, LDR, NPL, DER, and CIR. The analysis technique used was regression analysis. The results showed that CAR and LDR have positive and significant effect on ROA. CIR has a negative and significant effect on ROA. NPL has positive and insignificant effect on ROA. DER has negative and insignificant effect on ROA.

Suvita Jha & Xiaofeng Hui (2012) examine the comparative financial performance of commercial banks which is a case study in Nepal. The research was conducted on the variable of ROA, NPL, IETTTL (Interest Expense / Total Loans), CDR (Credit to Deposit Ratio). Technical analysis used is regression analysis. The results showed that CAR and IETTTL had a negative and significant effect on ROA. NPL has negative and insignificant effect on ROA. NIM has a

positive and significant effect on ROA. CDR has no significant positive effect on ROA.

Vincent Okoth Ongore & Gemechu Berhanu Kusa (2013) examines the factors that determine the financial performance of commercial banks in Kenya. The study was conducted on ROA, CAR, management efficiency, asset quality, liquidity ratio, GDP, and inflation. Technical analysis used is regression analysis. The results showed that CAR and management efficiency have a positive and significant effect on ROA. Asset quality and inflation have a negative and significant effect on ROA. The liquidity ratio does not affect the performance of banks in Kenya. GDP has negative and insignificant effect on ROA.

Muhammad Azam & Sana Siddiqui (2012) examines the differences and determinants of profitability of domestic banks and foreign banks in Pakistan. The study was conducted on ROA, CAR, NIM, and CIR (Cost to Income Ratio) variables. Technical analysis used is regression analysis. The results showed that CAR had a significant negative effect on domestic banks' ROA and was significantly positive for foreign bank ROA. NIM has a significant positive effect on the ROA of domestic banks and foreign banks. CIR has a significant negative effect on the ROA of domestic banks and foreign banks. Domestic banks in Pakistan generate greater profits than foreign banks, but foreign banks in Pakistan have better capital efficiency than domestic banks.

Arief Putranto, Aldrin Herwany, Erman Sumirat (2014) examines the determinants of the profitability of commercial banks in Indonesia. The research was conducted on ROA, CAR, NPL, CIR, SIZE, Capitalization, Market Share of Third Party Funds, and Market Share of Credits variables. Technical analysis used is regression analysis. The results showed that CAR, NPL, and CIR have negative and significant effect on ROA. SIZE has no significant effect on ROA. Market Capitalization, Market Share of Third Party Funds, and Market Share of Credits have a positive and significant effect on ROA.

Tan Sau Eng (2013) examines the effects of NIM, CIR, LDR, NPL and CAR on the ROA of the International Bank and the National Bank Go Public for the period of 2007 - 2011. The research was conducted on ROA, CAR, NPL, LDR, NIM, and CIR variables. Technical analysis used is regression analysis. The results showed that CAR and CIR have no significant effect on ROA. NPL and LDR have a negative and significant effect on ROA. CIR has no effect on ROA. NIM has a positive and significant effect on ROA.

Mokhammad Anwar & Aldrin Herwany (2006) examines the factors affecting bank profitability in Indonesia with empirical studies for government banks and non-foreign private banks. The research was conducted on LOTA (Loans to Total Assets) variables, TSTD (Time and Saving Deposits to Total Assets), CRTA (Loans to Deposits Ratio), and LOGTA (Logarithm of Total Assets Firm Size). Technical analysis used is regression analysis. Based on ROA measurement, it has seen that all internal variables (ROA and ROE) influence profitability (ROA and ROE) and variables that predict bank profitability are CRTA (Capital Reserves to Total Assets) and TETA (Total Expenses To Total Assets). LDR has a positive and significant effect on ROA and ROA.

Houssef Rachdi (2013) examines the factors affecting bank profitability during and before the world financial crisis with data from banks in Tunisia. Technical analysis used is regression analysis. The research was conducted on ROA, ROE, NIM, CAR, liquidity, CIR, yearly growth of deposit, SIZE, GDP, and inflation. The results showed that before the international financial crisis, CAR showed a positive and significant impact on ROA and NIM, but negative and not significant to ROE. Liquidity positively affects the performance of banks in Tunisia before and after the crisis. CIR, yearly growth of deposit, and SIZE have a negative and significant effect on bank profitability. GDP growth has a significant positive effect on profitability. Before the international crisis, inflation had a negative and significant effect, and after the crisis had no effect except for ROA.

Sudiyatno, Bambang & Asih Fatmawati (2013) examines the effect of credit risk and operational efficiency on bank performance (empirical study on banks listed in Indonesia Stock Exchange). The study was conducted on CAR, LDR, CIR, and ROA variables. Technical analysis used is regression analysis. The results showed that CAR and LDR had positive and insignificant effect on ROA. CIR has a negative and significant effect on ROA.

Arlina Susanto & I G B Wiksuana (2014) examines the Non-Performing Loan and Operational Expenses on Operational Income as a predictor of Return on Assets and the effect on Price Earning Ratio in Banking Companies in Indonesia Stock Exchange. The research was conducted on ROA, NPL, CIR, and PER (Price Earning Ratio) variables. Technical analysis used is regression analysis. The results showed that NPL and CIR have negative and significant effect on ROA. NPL and CIR have negative and insignificant effect on PER. ROA has a positive and significant effect on PER. ROA is able to mediate the influence of CIR on PER.

3. DATA AND METHODOLOGY

3.1 Data

This research uses secondary data from published financial statements of commercial banks in Indonesia published through www.bi.go.id or www.ojk.go.id or other official publications media in 2011 - 2015. The population of this study are all domestic banks and foreign banks in Indonesia that are operating between 2011 and 2015. The population of banks in Indonesia is 118 banks, consisting of 108 domestic banks and 10 foreign banks. There are 10 domestic banks that do not meet the criteria (do not earn profit and merge during period of 2011-2015), therefore the total samples are 102 banks, consist of 92 domestic banks and 10 foreign banks.

While the related indicators of this research are contained in the following framework:

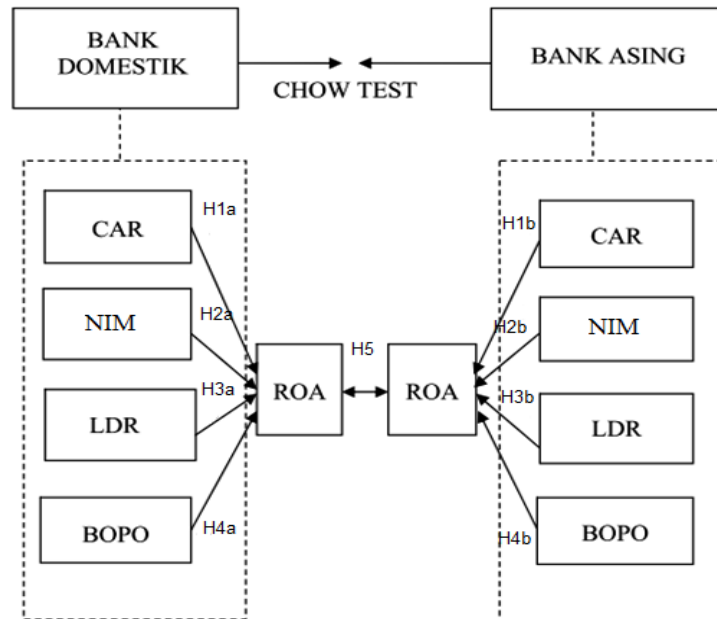

Source : Awdeh (2005), Hutagalung *et al.* (2013), Eng (2013), Purwana (2009) & being developed for this study

3.2 Operational Definition of Variables

Dependent variable is a variable whose value is influenced by independent variable. Dependent variable in this research is ROA. Independent variables are the variables that cause the occurrence or influence of the dependent variable. The independent variables in this research are CAR, NIM, LDR, and CIR.

No	Variable	Operational Definition	Measurement	Scale
1	ROA	Percentage of earning before tax to total assets	$\frac{\text{Earning Before Asset}}{\text{Total Assets}} \times 100\%$	%
2	CAR	Percentage of Capital to Risk Weighted Assets Ratio	$\frac{\text{Capital}}{\text{Risk weighted Asset}} \times 100\%$	%
3	NIM	Percentage of net interest income to average earning assets	$\frac{\text{Net Interest Income}}{\text{Average Earning Asset}} \times 100\%$	%
4	LDR	Percentage of loans to deposits	$\frac{\text{Loans}}{\text{Deposits}} \times 100\%$	%
5	CIR	Percentage of operating cost and operating income	$\frac{\text{Total Operating Cost}}{\text{Total Operating Income}} \times 100\%$	%

Source: SE BI No. 13/30 / DPNP dated 16/12/2011 where the formula is adjusted to be in percentage scale (%) therefore the calculation is multiplied 100% in the measurement.

3.3 Method of Analysis

The method of analysis used in this research is quantitative method. The multiple regression equation is being used as the method of analysis, but the data must qualified normality test, multicollinearity test, heterocedasticity test, autocorrelation test. Next, it will be examined about hypothesis testing (R Square test, F test, t test) and Chow test.

The regression models of the study are as follows:

$$ROA = a + b_1 CAR + b_2 NIM + b_3 LDR + b_4 CIR + e.$$

Notes:

a = constants

$b_1, b_2, b_3, b_4, b_5, b_6$ = Independent Regression Coefficient of Independent

e = error term

4. DATA ANALYSIS

4.1 Descriptive Statistics

The samples used in this study were 102 banks consisting of 92 domestic banks and 10 foreign banks in 2011 - 2015. The descriptive statistics of the data used in this research, are as follows:

Table 3. Descriptive Statistics of Domestic Banks

	N	Minimum	Maximum	Mean	Std. Deviation
CAR	460	9.57	146.14	20.9495	11.61974
NIM	460	.78	34.01	6.2548	3.02087
LDR	460	13.96	291.04	88.5928	29.85400
CIR	460	45.72	100.77	81.4059	11.14896
ROA	460	.01	7.44	2.1313	1.28333
Valid N (listwise)	460				

Source: Proceed

Table 4. Descriptive Statistics of Domestic Banks

	N	Minimum	Maximum	Mean	Std. Deviation
CAR	50	14.10	84.53	39.0808	21.39314
NIM	50	.78	6.76	3.3622	1.30615
LDR	50	42.57	559.97	146.5746	119.54375
CIR	50	38.76	99.62	76.2022	16.62277
ROA	50	.02	5.55	2.5502	1.36465
Valid N (listwise)	50				

Source: Proceed

Based on Table 3 and Table 4, average CAR values of domestic and foreign banks are 20.95% and 39.08% which are more than the minimum requirements set by Bank Indonesia (min. 8%). Average NIM values of domestic and foreign banks are 6.25 and 3.36% which are healthy banks at least have 2% of

NIM. Average CIR values of domestic and foreign banks are 81.41% and 76.20% which are less than the maximum requirements set by Bank Indonesia (max. 90%). Average LDR values of domestic and foreign banks are 88.59% and 119.54% which are good for domestic banks and not good for foreign banks; because the average LDR of foreign banks is exceeded the Bank Indonesia requirements range for LDR (78%-92%). Average ROA values of domestic and foreign banks are 2.13% and 2.55% which are higher the better.

4.2 Coefficient of Determination

Table 5. Domestic Banks Coefficient of Determination

Model	R	R Square	Adjusted R Square	Std. Error of the Estimate
1	.989 ^a	.979	.979	.16325

a. Predictors: (Constant), CIR, CAR, LDR, NIM

b. Dependent Variable: ROA

Source: Proceed

Table 6. Foreign Banks Coefficient of Determination

Model	R	R Square	Adjusted R Square	Std. Error of the Estimate
1	.903 ^a	.816	.767	.59355

a. Predictors: (Constant), CIR, NIM, LDR, CAR

b. Dependent Variable: ROA

Source: Proceed

Based on Table 5 and Table 6, it can be seen the domestic and foreign banks coefficient of determination (R^2) that indicates the proportion of the variance in the dependent variable that is predictable from the independent variables. The Adjusted R^2 value of domestic banks showed 97.90% variation of domestic banks ROA can be explained by the variation of the independent variables (CAR, NIM, LDR, and CIR). The Adjusted R^2 value of domestic banks showed 76.70% variation of foreign banks ROA can be explained by the variation of the independent variables (CAR, NIM, LDR, and CIR).

4.3 F-Test

Table 7. F-Test Result of Domestic Banks

Model		Sum of Squares	df	Mean Square	F	Sig.
1	Regression	396.285	4	99.071	3717.307	.000 ^a
	Residual	8.475	318	.027		
	Total	404.760	322			

a. Predictors: (Constant), CIR, CAR, LDR, NIM

b. Dependent Variable: ROA

Source: Proceed

Table 8. F-Test Result of Foreign Banks

Model		Sum of Squares	df	Mean Square	F	Sig.
1	Regression	23.442	4	5.861	16.635	.000 ^a
	Residual	5.284	15	.352		
	Total	28.727	19			

a. Predictors: (Constant), CIR, NIM, LDR, CAR

b. Dependent Variable: ROA

Source: Proceed

Based on Table 7 and Table 8, calculated F-test of domestic and foreign banks are bigger than F table with the significance value of 0,000. Because the value of significance is less than 0.05, therefore the regression model is feasible or has a goodness of fit. In addition, this regression model can be used to predict ROA or CAR, NIM, LDR, CIR together affect the ROA.

4.4 T-Test

Table 9. T-Test Result of Domestic Banks

Model		Unstandardized Coefficients		Standardized Coefficients	t	Sig.
		B	Std. Error	Beta		
1	(Constant)	9.309	.111		84.170	.000
	CAR	-.005	.001	-.037	-4.549	.000
	NIM	.119	.004	.256	28.996	.000
	LDR	-.001	.001	-.018	-2.238	.026
	CIR	-.095	.001	-.864	-98.394	.000

a. Dependent Variable: ROA

Source: Proceed

Based on Table 9, it can be compiled multiple linear regression equation as follows:

$$\text{ROA} = 9,309 - 0,005 \text{ CAR} + 0,119 \text{ NIM} - 0,001 \text{ LDR} - 0,095 \text{ CIR}$$

Table 10. T-Test Result of Foreign Banks

Model		Unstandardized Coefficients		Standardized Coefficients	t	Sig.
		B	Std. Error	Beta		
1	(Constant)	7.400	1.243		5.954	.000
	CAR	-.032	.007	-.611	-4.689	.000
	NIM	.198	.095	.256	2.089	.054
	LDR	-.006	.005	-.156	-1.365	.192
	CIR	-.048	.014	-.415	-3.424	.004

a. Dependent Variable: ROA

Source: Proceed

From Table 10, it can be compiled multiple linear regression equation as follows:

$$\text{ROA} = 7,400 - 0,032 \text{ CAR} + 0,198 \text{ NIM} - 0,006 \text{ LDR} - 0,048 \text{ CIR}$$

4.5 Research Results

4.5.1 Domestic Banks Results

CAR of domestic banks shows negative and significant impact on ROA of domestic banks. This is in contrast to previous researches from Irmawati & Lestari (2014), Mayes & Stremmel (2012), Rahman *et al* (2015), Ongore & Kusa (2013) which found CAR had positive impact on ROA. But the result of this study is consistent with the researches by Putranto *et al.* (2014), Jha & Hui (2012), and Azam & Siddiqui (2012) which found that CAR had significant negative impact on ROA. Bank with higher capital than their target capital demonstrated a negative effect towards profitability. This is related to the tradeoff theory of capital structure that says that companies balance their benefits of debt with the financial distress cost of debt. Apparently, based on this theory, the domestic banks are indicated to have capital values above their optimal target values. Besides, CAR values of domestic banks are too high. This condition is not very good, even though the bank's solvency is safe, but the fund that has been allocated to the CAR will become less useful and the bank will lose the opportunity to expand its business to increase profitability.

NIM of domestic banks shows positive and significant impact on ROA of domestic banks. The results of this study are supported by the researches of Hutagalung *et al* (2013), Azam & Siddiqui (2012), and Raharjo *et al* (2014) which are showed that NIM had positive and significant impact on ROA. Net interest income is one of the NIM components. Any increase in net interest income, which is the difference between the total interest cost and the total interest income resulting in an increase in profit before tax, which in turn leads to an increase in ROA. This means that the bank's management capability in generating net interest income affects the bank's income level for its total assets.

LDR of domestic banks shows negative and significant impact on ROA of domestic banks. This is in contrast to previous researches from Maharani & Sugiharto (2007), Rengasamy (2014) which found LDR had positive impact on ROA. But the result of this study is consistent with the researches by Gelos (2006), Putranto *et al.* (2014), Widiarti *et al.* (2015) which are showed that LDR had positive and significant impact on ROA. The LDR values of domestic banks show that majority of the samples are exceed the bottom and the upper limit of the Bank Indonesia requirements range for LDR (78%-92%). Only 40.87% of the samples are in the range of the Bank Indonesia requirements range for LDR. This makes the LDR have negative impact on ROA.

CIR of domestic banks shows negative and significant impact on ROA of domestic banks. The results of this research are supported by research from Hutagalung (2013), Putranto *et al* (2014), Susanto & Wiksuana (2014) which showed that CIR has negative and significant impact on ROA. Achieving a high level of efficiency means that management has managed to efficiently utilize their resources. The high ratio of CIR indicates that the bank has not been able to utilize its resources or has not been able to run its operations efficiently, so that will result in decreased

profitability. The smaller ratio of CIR shows the more efficient the bank in carrying out its business activities, so the opportunity to gain more benefits will be higher.

4.5.2 Foreign Banks Results

CAR of foreign banks shows negative and significant impact on ROA of domestic banks. This is in contrast to previous researches from Irmawati & Lestari (2014), Mayes & Stremmel (2012), Rahman *et al* (2015), Ongore & Kusa (2013) which found CAR had positive impact on ROA. But the result of this study is consistent with the researches from Putranto *et al.* (2014), Jha & Hui (2012), and Azam & Siddiqui (2012) which found that CAR had significant negative impact on ROA. Bank with higher capital than their target capital demonstrated a negative effect towards profitability. This is related to the tradeoff theory of capital structure that says that companies balance their benefits of debt with the financial distress cost of debt. Apparently, based on this theory, the domestic banks are indicated to have capital values above their optimal target values. Besides, CAR values of foreign banks are too high. This condition is not very good, even though the bank's solvency is safe, but the fund that has been allocated to the CAR will become less useful and the bank will lose the opportunity to expand its business to increase profitability.

NIM of foreign banks shows positive and insignificant impact on ROA of foreign banks. The results of this study are in contrast with the researches of Hutagalung *et al* (2013), Azam & Siddiqui (2012), and Raharjo *et al* (2014) which are showed that NIM had positive and significant impact on ROA. But the result of this study is consistent with the research from Widiarti *et al.* (2015) which found that NIM had insignificant impact on ROA. In contrast to domestic banks whose main income is based on net interest income, while the main income of foreign banks are from fee based income. Therefore NIM has insignificant impact on ROA.

LDR of foreign banks shows negative and insignificant impact on ROA of domestic banks. This is in contrast to previous researches from Maharani & Sugiharto (2007), Rengasamy (2014) which found LDR had positive impact on ROA. But the result of this study is consistent with the researches from Jumono *et al* (2015) which is showed that LDR had insignificant impact on ROA. The LDR values of foreign banks show that majority of the samples are exceed the bottom and the upper limit of the Bank Indonesia requirements range for LDR (78%-92%). Only 20% of the samples are in the range of the Bank Indonesia requirements range for LDR. Besides, the main income of foreign banks is from the fee based income that does not related to loan which means it is not significantly related to LDR.

CIR of foreign banks shows negative and significant impact on ROA of foreign banks. The results of this research are supported by research from Hutagalung (2013), Putranto *et al* (2014), Susanto & Wiksuana (2014) which showed that CIR has negative and significant impact on ROA. Achieving a high level of efficiency means that management has managed to efficiently utilize their resources. The high ratio of CIR indicates that the bank has not been able to utilize its resources or has not been able to run its operations efficiently, so that will result in decreased profitability. The smaller ratio of CIR shows the more efficient the bank in carrying out its business activities, so the opportunity to gain more benefits will be higher.

4.5.3 The Difference Impact of CAR, NIM, LDR, and CIR on ROA at Domestic and Foreign Banks

Based on the Chow test result shows that there is the difference impact of CAR, NIM, LDR, and CIR on ROA at domestic banks and foreign banks. CAR, NIM, LDR, and CIR impact on domestic banks ROA, while the ROA of foreign banks only be impacted by CAR and CIR. Domestic and foreign banks have different characters and performances; therefore the independent variables that impact on ROA are different.

5. CONCLUSION

According to the results of data analysis and previous discussion, it can be concluded as follows:

- a. NIM has the greatest and significant impact on ROA at the domestic banks with coefficient value of 0.119, after that followed by CIR with coefficient of -0.95, CAR with coefficient of -0.005, and LDR with coefficient value of -0,001. Therefore the bank management should give special attention to those four variables. We recommend that the bank management should increase NIM, by increasing the net interest income so the profitability can increase significantly and suppressed the CIR by doing the business activities efficiently. The management also has to keep the CAR and LDR in optimal position and still in the range of Bank Indonesia requirements to increase the ROA of domestic banks. It can be done not only by increasing the loan to get more interest income, but also increase the fee based income of domestic banks.
- b. There are only CIR and CAR variables that give significant impact on ROA of foreign banks. CIR has the greatest and significant impact on ROA of foreign banks with values of -0.048. After that followed by CAR with coefficient of -0.032. NIM and LDR don't give significant impact on ROA, because the main incomes of foreign banks are from fee based income, not from loans that can be related to NIM and LDR. We highly recommend that the bank management should pay special attention to CIR and CAR of foreign banks in order to increase the profitability by doing the business activities efficiently and to keep the CAR in optimal position and still in the range of Bank Indonesia requirements to increase the ROA of foreign banks.

REFERENCES

- Ali, Masyhud. (2004). Asset Liability Management : Menyasati Risiko Pasar dan Risiko Operasional. PT Gramedia Jakarta.
- Almazari, Ahmad Aref. (2014). Impact of Internal Factors on Bank Profitability: Comparative Study between Saudi Arabia and Jordan. *Journal of Applied Finance & Banking*, vol. 4, no. 1, 2014, 125-140 ISSN: 1792-6580 (print version), 1792-6599 (online) Scienpress Ltd, 2014
- Ariyanto, Taufik. (2004). Profil Persaingan Usaha Dalam Industri Perbankan Indonesia. *Perbanas Finance and Banking Journal*.

- Awdeh, Ali. (2005). *Domestik Bank's and Foreign Bank's Profitability : Differences and their Determinants*, Cass Business School, City Of London, Paper.
- Azam, Muhammad & Sana Siddiqui. (2012). *Domestik and Foreign Banks' Profitability: Differences and Their Determinants*. *International Journal of Economics and Financial Issues* Vol. 2, No. 1, 2012, pp.33-40
- Dendawijaya, Lukman. (2005). *Manajemen Perbankan*, Penerbit Ghalia Indonesia, Jakarta.
- Eng, Tan Sau. (2013). *Pengaruh NIM, CIR, LDR, NPL dan CAR Terhadap ROA Bank Internasional dan Bank Nasional Go Public periode 2007 – 2011*. *Jurnal Dinamika Manajemen* Vol. 1 No. 3 Juli – September 2013
- Gelos, R Gaston. (2006). *Banking Spreads in Latin America*. IMF Working Paper, International Monetary Fund.
- Ghozali, Imam. (2011). *Aplikasi Analisis Multivariate dengan Program SPSS*, Edisi 5, Badan Penerbit Universitas Diponegoro, Semarang.
- Hadad, Muliaman D.; Wimboh Santoso; Dwityapoetra S Besar; Ita Rulina; Wini Purwanti; Ricky Satria. (2004). *Fungsi Intermediasi Bank Asing Dalam Mendorong Pemulihan Sektor Riil di Indonesia*. <http://www.bi.go.id/id/publikasi/perbankan-dan-stabilitas/riset/Pages/Fungsi%20Intermediasi%20Bank%20Asing%20Dalam%20Mendorong%20Pemulihan%20Sektor%20Riil%20di%20Indonesia.aspx>
- Husnan, Suad. (1998). *Manajemen Keuangan – Teori dan Penerapan*, Buku 2.
- Hutagalung, Esther Novita, Djumahir, & K. Ratnawati. (2013). *Analisa Rasio Keuangan terhadap Kinerja Bank Umum di Indonesia*. *Jurnal Aplikasi Manajemen* Vol. 11 No. 1 Maret 2013.
- Indriatmo, Nur & Bambang Supomo. (2002). *Metodologi Penelitian Bisnis untuk Akuntansi dan Manajemen*. BPFE : Yogyakarta.
- Irmawati & Dewi Lestari. (2014). *Analisis Pengaruh Rasio CAR, CIR, dan LDR Terhadap Kinerja Keuangan Perbankan Yang Terdaftar Di Bursa Efek Indonesia Tahun 2008 – 2012*. *Seminar Nasional Dan Call For Paper Program Studi Akuntansi – Feb UMS*, 25 Juni 2014.
- Jha, Suvita & Xiaofeng Hui. (2012). *A comparison of financial performance of commercial banks: A case study of Nepal*. *African Journal of Business Management* Vol. 6(25), pp. 7601-7611, 27 June, 2012.
- Jumono, Sapto; Noer A. Achsani; Dedi B. Hakim; & Muhamad Fidaus. (2015). *Market Concentration, Market Share, and Profitability (Study at Indonesian Commercial Banking in the Period of 2001-2012)*. *Asian Social Science*; Vol. 11, No. 27; 2015; ISSN 1911-2017 E-ISSN 1911-2025; Published by Canadian Center of Science and Education.
- Kasmir. (2005). *Bank dan Lembaga Keuangan Lain*. PT Raja Grafindo Perkasa Edisi 6. Jakarta.
- Khrawish, H.A. (2011) *Determinants of Commercial Banks Performance: Evidence from Jordan*. *International Research Journal of Finance and Economics*. Zarqa University, 5(5), 19-45
- Koch, W. Timothy. (1997). *Bank Management*. The Dryden Press – International Edition.

- Laurence A Manullang. (2002). Analisis Pengaruh Rentabilitas terhadap Rasio Kecukupan Modal pada Bank Tabungan Pensiunan Nasional. *Media Riset Bisnis dan Manajemen*, Vol. 2, No 1, 2002, pp. 26-47.
- Machfoedz, Mas'ud, 1999, "Pengaruh Krisis Moneter pada Efisiensi Perusahaan Publik di Bursa Efek Jakarta", *Jurnal Ekonomi dan Bisnis Indonesia*, Vol. 14, No. 1, Hal. 37—49
- Maharani Ika Lestari & Toto Sugiharto. (2007). Kinerja Bank Devisa dan Bank Non Devisa dan Faktor-Faktor yang Mempengaruhinya. *Proceeding PESAT*.
- Mawardi, W. (2005). "Analisa Faktor Faktor yang Mempengaruhi Kinerja Keuangan Bank Umum di Indonesia (Studi Kasus pada Bank Umum dengan Total Asset Kurang dari 1 Triliun)", *Jurnal Bisnis Strategi*, Vol.14, No.1, Juli, pp.83–94.
- Mayes, David G & Hanno Stremmel. (2012). The Effectiveness of Capital Adequacy Measures in Predicting Bank Distress. *JEL Classification*
- Moeljono, Teguh Pudjo. (2011). *Analisa Laporan Keuangan untuk Perbankan*. Edisi Revisi 1999, Cetakan 11, Jakarta Djambatan, 2011.
- Mokhamad Anwar & Aldrin Herwany (2006) *The Determinants of Successful Bank Profitability in Indonesia : Empirical Study for Provincial Government's Banks and Private Non-Foreign Banks*. Working Papers in Business, Management and Finance 200601, Department of Management and Business, Padjadjaran University, revised Jan 2006.
- Muljono, Teguh Pudjo (1999). *Analisa Laporan Keuangan Untuk Perbankan*. Edisi Revisi 1999, Cetakan 6, Jakarta Djambatan, 1999.
- Myers, Steward C. (2001). Capital Structure. *The Journal of Economic Perspectives*, Vol. 15, No. 2. (Spring, 2001), pp. 81-102.
- Ongore, Vincent Okoth & Gemechu Berhanu Kusa. (2013). Determinants of Financial Performance of Commercial Banks in Kenya. *International Journal of Economics and Financial Issues* Vol. 3, No. 1, 2013, pp.237-252
- Otoritas Jasa Keuangan. (2014). Bank Umum. <http://www.ojk.go.id/bank-umum>
- Peraturan Bank Indonesia No 15/ 12 /PBI/2013
- Peraturan Bank Indonesia No 15/15/PBI/2013
- Purwana, Edward Gagah. (2009). Analisis Pengaruh Capital Adequacy Ratio (CAR), Loan To Deposit Ratio (LDR), Size, CIR Terhadap Profitabilitas (Studi Perbandingan Pada Bank Domestik dan Bank Asing Periode Januari 2003-Desember 2007). Tesis Program Pasca Sarjana Magister Manajemen Universitas Diponegoro (dipublikasikan).
- Putranto, Arief, A. Herwany, & E. Sumirat. (2014). The Determinants of Commercial Bank Profitability in Indonesia. <http://ssrn.com/abstract=2456092> or <http://dx.doi.org/10.2139/ssrn.2456092>
- Raharjo, Gesang; Dedi Budiman Hakim; Adler Hayman Manurung; Tubagus N.A. Maulana. (2014). The Determinant of Commercial Banks' Interest Margin in Indonesia : An Analysis of Fixed Effect Panel Regression. *International Journal of Economics and Financial Issues* Vol. 4, No. 2, 2014, pp.295-308; ISSN: 2146-4138. www.econjournals.com

- Rahman, Mohammad Morshedur, Md. Kowsar Hamid, & Md. Abdul Mannan Khan. (2015). Determinants of Bank Profitability: Empirical Evidence from Bangladesh. *International Journal of Business and Management*; Vol. 10, No. 8; 2015. ISSN 1833-3850 E-ISSN 1833-8119. Published by Canadian Center of Science and Education
- Rengasamy, Dhanuskodi. (2014). Impact of Loan Deposit Ratio (LDR) to Profitability : Panel Evidence from Commercial Banks in Malaysia. *Proceedings of Third International Conference on Global Business, Economics, Finance and Social (GB14 Mumbai Conference) Mumbai, India. 19-21 December 2014.* ISBN: 978-1-941505-21-2
- Siringoringo, Renniwaty. (2012). Karakteristik dan Fungsi Intermediasi Perbankan di Indonesia. *Buletin Ekonomi Moneter dan Perbankan*, Juli 2012
- Subandi & Imam Ghozali. (2013). Determinan Efisiensi dan Dampaknya Terhadap Kinerja Profitabilitas Industri Perbankan di Indonesia. *Jurnal Keuangan dan Perbankan*, Vol.17, No.1 Januari 2013, hlm. 123–135
- Sudiyatno, Bambang & Asih Fatmawati. (2013). Pengaruh Risiko Kredit dan Efisiensi Operasional Terhadap Kinerja Bank (Studi Empirik pada Bank yang Terdaftar di Bursa Efek Indonesia). *Jurnal Organisasi dan Manajemen, Volume 9, Nomor 1, Maret 2013, 73-86*
- Sudiyatno, Bambang & Jati Suroso. (2010). Analisis Pengaruh Dana Pihak Ketiga, CIR, CAR, dan LDR Terhadap Kinerja Keuangan Pada Sektor Perbankan Yang Go Public di Bursa Efek Indonesia (BEI) (Periode 2005 – 2008). *Dinamika Keuangan dan Perbankan*, Mei 2010 Vol. 2, No. 2, Hal 125 – 137.
- Sukarno, Kartika Wahyu dan Muhamad Syaichu. 2006. Analisis Faktor-faktor yang Mempengaruhi Kinerja Bank Umum di Indoensia. *Jurnal Studi Manajemen dan Organisasi*. Vol 3 No 2 Tahun 2006.
- Susanto, Arlina & I G B Wiksuana. (2014). Non Performing Loan dan Beban Operasional Terhadap Pendapatan Operasional Sebagai Prediktor Return on Asset Serta Pengaruhnya Terhadap Price Earning Ratio Pada Perusahaan Perbankan di Bursa Efek Indonesia. ISSN : 2337-3067, E-*Jurnal Ekonomi dan Bisnis Universitas Udayana* 3.11 (2014) : 674-688.
- Susilo, Y.S., S. Triandaru, & A.T.B. Santoso. (2000). *Bank & Lembaga Keuangan Lain*. Jakarta : Salemba Empat.
- Taswan. (2010). *Manajemen Perbankan Konsep, Teknik, & Aplikasi*. UPP STIM YKPN. Yogyakarta.
- Viverita, Arief W. Lubis, Yosman Bustaman, and Ririen S. Rianti. (2014). Does Foreign Bank Entry Improve Credit Allocation and Lending Rates? : Evidence from Indonesia. *SRRN Electronic Journal* 01/2014.
- Widiarti, Astoeti Wahjoe; Hermanto Siregar; Trias Andati. (2015). The Determinants of Bank's Efficiency In Indonesia. *Buletin Ekonomi Moneter dan Perbankan, Volume 18, Nomor 2, Oktober 2015*