

Thermal modelling of extrusion based additive manufacturing of composite materials

Jensen, Mathias Laustsen; Sonne, Mads Rostgaard; Hattel, Jesper Henri; Hansen, Hans Nørgaard

Published in:

Proceedings of the 21s International Conference on Composite Materials (ICCM-21)

Publication date:

2017

Document Version

Early version, also known as pre-print

[Link back to DTU Orbit](#)

Citation (APA):

Jensen, M. L., Sonne, M. R., Hattel, J. H., & Hansen, H. N. (2017). Thermal modelling of extrusion based additive manufacturing of composite materials. In Proceedings of the 21s International Conference on Composite Materials (ICCM-21)

DTU Library

Technical Information Center of Denmark

General rights

Copyright and moral rights for the publications made accessible in the public portal are retained by the authors and/or other copyright owners and it is a condition of accessing publications that users recognise and abide by the legal requirements associated with these rights.

- Users may download and print one copy of any publication from the public portal for the purpose of private study or research.
- You may not further distribute the material or use it for any profit-making activity or commercial gain
- You may freely distribute the URL identifying the publication in the public portal

If you believe that this document breaches copyright please contact us providing details, and we will remove access to the work immediately and investigate your claim.

Thermal modelling of extrusion based additive manufacturing of composite materials

Mathias L. Jensen^{1,2}, Mads R. Sonne², Jesper H. Hattel², Hans N. Hansen²

¹ Innovation and Concepts, Vestas Wind Systems, 8200 Aarhus N, Denmark, malaj@vestas.com, www.vestas.com

² Department of Mechanical Engineering, Technical University of Denmark, 2800 Lyngby, Denmark, <http://www.dtu.dk>

Keywords: Additive manufacturing, Thermal analysis, Numerical modelling, finite volume discretisation, initial study.

ABSTRACT

One of the hottest topics regarding manufacturing these years is additive manufacturing (AM). AM is a young branch of manufacturing techniques, which by nature is disruptive due to its completely different manufacturing approach, wherein material is added instead of removed. By adding material layer by layer, mould and customised tooling requirements from the conventional manufacturing are reduced or removed, which leads to increased customisation options and enables new part complexities without increasing the manufacturing cost. AM hence enables customised small volume productions of composite parts not feasible by conventional manufacturing techniques. This sets up new requirements to the part verification and validation, while conventional destructive tests become too expensive. This initial study aims to investigate alternative options to this destructive testing by increasing process knowledge, and validating the generated toolpaths before the real manufacturing process takes place: Hence removing time consuming and expensive trial-and-error processes for new products. This study applies a 2D restricted finite volume model aimed to describe thermoplastic Acrylonitrile-butadiene-styrene (ABS) and thermosetting polyurethane (PU) material extrusion processes. During the experimental evaluation of the produced models it is found that some critical material properties needs to be further investigated to increase the precision of the model. It is however also found that even with only sparse material property information, the simulations show quite accurate temperature simulations when compared to the experimental results. Additionally it is during the thermoplastic experiments seen that the temperature characteristic of the simulations is in in good agreement with the ones obtained from the experiments. Moreover it is found that the thermosetting experiments show increased reaction rate at higher catalyst concentrations which is in good agreement with the conducted simulation.

INTRODUCTION

In recent years additive manufacturing (AM) has experienced massive attention and significant advancements due to numerous new developments of the known processes. Each AM process is different, and of the thousands of different AM systems seen today, the American Society for Testing and Materials International (ASTM), continuously try to make an overall structure standard capable to describe the different systems as simply as possible. This is a difficult task while many of the different systems are inspired from the existing solutions resulting in hybrid approaches and new usages of the same system approach. So far the ASTM standard has managed to describe the presently known systems through seven overall categories; Vat photo-polymerization, powder bed fusion, sheet lamination, direct energy deposition, material extrusion, binder jetting and material jetting [1]. In this work only the material extrusion will be addressed (see figure 1), because it currently is the technique, which shows the largest potential for

integrating especially continuous fibers into plastic matrices for composite creation. The advancements currently being made with other techniques especially the sheet lamination in terms of composite manufacturing should not be neglected. However the material extrusion based techniques have so far seen the largest industrial impact, particularly in the field of chopped fiber/ medium quality thermoplastic composites for increased material properties.

These years' material properties is a hot topic and heavy research into improved material properties have increased the available materials for the AM processes leading to the fact that more and more applications are directly made from AM techniques. In the years from 2003 to 2016 the AM industry has experienced a drastic change wherein the amount of final parts made in the AM field has increased from about 3.9% to 51.3% globally, with no signs of this development slowing down [1]. This change is driven as improved material properties are discovered, and with the addition of different plastic composite AM printers like MarkForged (company), Impossible Objects (company) and envisionTEC SLCOM1 (company product), plastic AM is experiencing an increased awareness as a final component process.

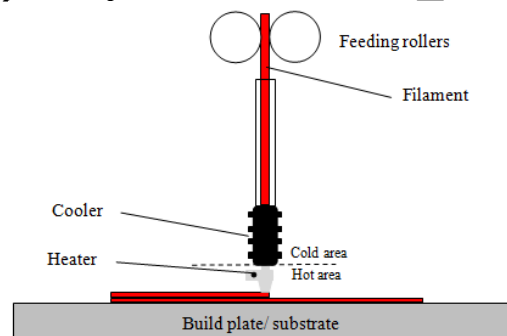

Figure 1: Sketch of a typical material extrusion based process.

Introducing AM to plastic composites enables the potential of large-scale high-strength/light-weight component manufacturing, but with the increased size and the added complexities of the orthorhombic properties of the composites new problems emerge. These include both physical and chemical factors, ranging from micro- to macro-scale and being dependent on the used AM technique and size range. One of the problems encountered in material extrusion based processes, when going up in scale, is increased volumetric throughput. A throughput that might lead to increased thermal retention time in the plastic part resulting in increased thermal degradation of the part. When scaling the process the thermal propagation during manufacturing hence becomes of increasing concern. In this, the planned pathway sequence is one of the most critical factors directly affecting the final quality of the product and hence it is in the laid pathway that the product quality should be planned. Most slicing software these days (e.g. Cura, Slic3r, Simplified) aims towards a pathway generation wherein speed is the primary parameter being optimized, hereby neglecting the geometric factors that influence the different processes. Some of the most critical failure modes this might result in are warping issues due to complex stress builds during manufacturing and detrimental interlayer adhesion due to bad heat flow patterns during the manufacturing process. Furthermore only a few slicing programs enable deposition orientation of each individual layers to obtain ply-builds of the composites during prints, e.g. the Mark Forged Eiger software (commercial software). This restricts the ease of continuous fiber

deposition in AM processes and this is hence only seen industrially in the desktop printers from MarkForged. In the larger scale only chopped fiber depositions are found, whether being the Cincinatti BAAM (company product), Thermwood LSAM (company product) or others. So even though AM these years is increasingly based on composite processing machines, there are still hurdles to overcome in terms of software integration to optimize the material properties of the AM parts. Furthermore the lack of proper thermosetting processes reduces the application span of the AM composites.

Thermo-setting material extrusion based AM systems are not available commercially today, which could be due to the increased complexities found in such a process, wherein many process factors are interlinked. These include; varying viscosities, gelation point, temperature dependent curing etc., which further increase the difficulties in obtaining the right parameter setup needed for a quality product, while the optimal process pathway may vary with changing geometry to a larger extent than seen in the usual thermo-plastic printing. This is primarily controlled by the viscosity changes during the curing process. One of the most important factors here is the gelation point, where the material properties transform from viscous to solid, hence from this point significant internal strains and stresses can start to build due to chemical shrinkages, thermal expansion etc. Many of the resulting stresses in the final part of a thermosetting AM can thus be described by the process stresses introduced after the gelation point. To avoid large stresses in the part, the temperature needs to be controlled and since most polymerizations are exothermic this requires slow reactions. This gives the system a complex tradeoff mechanism for the printing process, because different factors affect in different directions. To take an example, for the stress state of the final part, the open window criterion (time in which additional layers can be applied to the previous) and the wetting of the fiber require slow reactions leading to heavy tooling investments due to the curing degree requirements to obtain form stable material needed for the deposition process. This is where the planned deposition pathway becomes critical while wrongfully placed strands at best introduce unnecessary stresses and at worse introduce crack initiation sites and warps. With all these complexities, trial and error solutions would be time consuming and too expensive, and hence an efficient simulation tool is required. This tool should be able to give detailed insight into the production of a given part, herein showing the required pathway for an optimal process design.

The simulation tool developed in this study aims to help the AM process manager to evaluate the planned pathway and predict troublesome areas, before performing extended simulations or manufacturing the actual product. It aims to provide a fast indication, rather than complex descriptions of the process, to provide quick inexpensive answers for verifying the feasibility of a planned process before going into the final design stage. Other simulation efforts seen in industry aim towards micro-scale molecular interaction simulations, mostly illustrated through moving heat source deposition approaches; mesoscale simulations that usually analyze different interactions layer by layer; or macro-scale simulations (e.g. Simufact) in which the different molecular interactions are neglected and the stresses and strains are calculated through a method of inherent strain, wherein the complex thermo-mechanical model is simplified to a mechanical-structural model [3]. The simulation tool of this study on the other hand aims to be in between the typical micro- and meso- scaled analysis span. In literature the analytical approaches typically describe effects of different deposition environments; e.g. flow depositions, tool paths, machine speeds etc. [6, 7, 8, 9]. The empirical models are typically addressing different aspects of the deposition parameters

to investigate the influence of e.g. layer height and deposition width [10, 11]. The numerical simulations are used to describe flow analysis [12], temperature development investigations [13], mechanical behavior [14], thermo-mechanical behavior [15, 16], deposition sequence influence [17] etc. These areas are typically described by numerical finite element analysis (FEA) based on moving heat source approaches, wherein material additions over time is used. For this approach the numerous movements often seen in AM processes makes it a computational heavy simulation, which requires significant computational power resulting in high time requirements to perform them [18]. In this, the time requirement might be the single largest factor making or breaking whether a simulation is usable or not, because it either has to be significantly cheaper than just making a pilot component or significantly faster. Besides the time and money saved implementing process simulations, it might be used as an evaluation tool for the AM process with e.g. thermal imaging feedback loops for part validation, hereby enabling mass customization. Today one of the greatest concerns threatening this mass customization is the conventional destructive evaluation methods needed to validate new parts, because it requires a certain amount of parts printed to validate a given geometry. So instead of printing one part you would have to print several hereby increasing the final cost of the part significantly. This could be improved by increased process knowledge and the in-depth understanding of how the different process parameters change the behavior of the produced part. This is where a tool like the one developed during this work might come in handy. The light micro-scaled description of the simulation problem in the material extrusion based system can potentially fill a gap in the process simulation community enabling speed while still providing the necessary in depth analysis.

METHOD

All the complexities introduced previously would unlikely be handled through analytical calculations alone, and even with the setup of a system of numerical equations the complexities of the process could lead to significant computational requirements. To avoid these heavy requirements it is hence critical to find the optimal balance between accuracy and simplicity, which is why this study aims to develop a simulation tool in the area between the typical micro- and meso-scaled simulations to get the required chemical insight at specific points of the product, without going entirely into the microscopic description of the physics. The approach chosen is hence a numerical finite volume solution of the governing equation for thermal conduction in solid material, which is based on Fourier's law and the first law of thermodynamics (conservation of energy) [16]. To simplify the simulations further the problem has been described as a 2D problem neglecting the printing direction. Additionally it is assumed that the deposition consists of sequential solid state material depositions, which can be described fully through thermal conduction and neglecting inputs from thermal radiation and thermal convection. With these assumptions the thermal problem can then be described as in a combination between Fourier's law and the first law of thermodynamics leading to the transient heat conduction equation (conservation of energy) [16]:

$$\rho * c_p * \frac{\partial T}{\partial t} = \frac{\partial}{\partial x} \left(\kappa * \frac{\partial T}{\partial x} \right) + \frac{\partial}{\partial y} \left(\kappa * \frac{\partial T}{\partial y} \right) + \dot{Q} \quad (1)$$

Where ρ is density, c_p is specific heat capacity, κ is thermal conductivity, \dot{Q} is a volumetric heat source term and T is the temperature.

By using the finite volume discretization for this equation and applying a fully implicit solution the discretization equations then become [17]:

$$b = a_a * T_{i,j}^{t+\Delta t} + a_b * T_{i-1,j}^{t+\Delta t} + a_c * T_{i+1,j}^{t+\Delta t} + a_d * T_{i,j-1}^{t+\Delta t} + a_e * T_{i,j+1}^{t+\Delta t} \quad (2)$$

$$a_a = H_{i,j}^{cap} + H_{i,j}^{conx} + H_{i,j+1}^{conx} + H_{i,j+1}^{cony} + H_{i,j}^{cony} \quad (2a)$$

$$a_b = -H_{i,j}^{conx} \quad (2b)$$

$$a_c = -H_{i,j+1}^{conx} \quad (2c)$$

$$a_d = -H_{i,j}^{cony} \quad (2d)$$

$$a_e = -H_{i,j+1}^{cony} \quad (2e)$$

$$b = T_{i,j}^t * H_{i,j}^{cap} + \dot{Q} \quad (2f)$$

Where $T_{i,j}^{t+\Delta t}$ is temperature at the new timestep at position $[i,j]$, $H_{i,j}^{cap}$ is the heat capacity term at position $[i,j]$, $H_{i,j}^{conx}$ is the x-axial conductivity term at position $[i,j]$, $H_{i,j+1}^{cony}$ is the y-axial conductivity term at position $[i,j+1]$ etc.

These equations give the expressions for the coefficients in the system of equations which results from the implicit discretization. In addition to this the curing is taken into account following the procedure given in [3]. Here the cure degree is described as a fraction of reaction enthalpy released at a given time:

$$\chi = \frac{H(t)}{H_r} \quad (3)$$

$$H(t) = \int_0^t \frac{1}{\rho} * \frac{dq}{dt} dt \quad (3a)$$

$$H_r = \int_0^{t_f} \frac{1}{\rho} * \frac{dq}{dt} dt \quad (3b)$$

Where χ is the cure degree. $H(t)$ is a function describing the reaction heat released at time t , H_r is the total heat of reaction, $\frac{dq}{dt}$ is the rate of heat generation from cure reaction $\left[\frac{J}{m^3 \cdot s}\right]$, ρ is density, t is time and t_f is the time for the complete reaction to have happened.

This combined and manipulated gives the equation describing the heat generated over time in terms of cure rates:

$$\frac{dq}{dt} = \rho * H_r * \frac{d\chi}{dt} \quad (4)$$

Where \dot{q} is heat rate $\left[\frac{J}{m^3 \cdot s}\right]$, ρ is density, H_r is the total reaction enthalpy, χ is curing degree and t is time.

The value calculated from this expression is then put into the generated heat description of the system (\dot{Q}) in an incremental manner to account for the mutual dependence between the curing process and the temperature field, which is done as follows:

$$q_{i,j}^t = \rho * H_r * \left(\frac{d\chi}{dt}\right)_{i,j}^t \quad (5)$$

Where $q_{i,j}^t$ is heat at time t and position $[i,j]$, ρ is density, H_r is the total reaction enthalpy, χ is curing degree and t is time.

With the description of the curing rate relation to the heat generation the curing degree can now be described in an incremental manner to include the time dependence of the term:

$$\chi_{i,j}^{t+\Delta t} = \chi_{i,j}^t + \left(\frac{d\chi}{dt}\right)_{i,j}^{t+\Delta t} * \Delta t \quad (6)$$

Where $\chi_{i,j}^t$ and $\chi_{i,j}^{t+\Delta t}$ is curing degree at position $[i,j]$ at time t and $t + \Delta t$ respectively. $\left(\frac{d\chi}{dt}\right)_{i,j}^{t+\Delta t}$ is curing degree rate at position $[i,j]$ at time $t + \Delta t$ and here Δt is time increment.

The cure rate description is typically received from experiments. It is strongly dependent of the specific plastic system and could be described through an auto catalytic reaction kinetic model [4] or a specific epoxy/glass cure equation used for specific laminate simulations [3]. In the current study simple second order reaction kinetics was applied, since previous studies have shown this to describe the unanalyzed polyurethane reaction quite well [5].

$$\frac{d\chi}{dt} = a * (b - \chi)^2 \quad (7)$$

Where $\frac{d\chi}{dt}$ is cure rate, a , b are constants and χ is cure rate.

Simulations

For the specific simulation of the AM process complexity is added through the continuously addition of material at specific times, which imposes strict timing aspects of the simulation. For present simulation the timing issue was addressed by firstly extracting the information provided by the G-code, then calculating the time needed for the specified pathway to reach each position within the process. This was done numerically so that the accuracy vs. computational requirements could be handled. Furthermore the code was programmed to register every time there would be overlaps in the g-code (i.e. when a layer would be placed upon another). By this, deposition interactions could be registered as a part of the evaluation tool. From here it was furthermore registered each time the deposition head would pass a sensor programmed into the coding and from this the sequence of depositions could be determined and used for the finite volume model. For the finite volume method description of the thermal propagation a 2D Matlab code was developed. It was based on the fully 2D- implicit approach of the previously shown equations [equation 2, 2a-f], wherein a system of equations is established:

$$\begin{bmatrix} 1 & 0 & \dots & 0 & 0 & 0 & \dots & 0 & 0 & 0 & \dots & 0 \\ 0 & 1 & \dots & 0 & 0 & 0 & \dots & 0 & 0 & 0 & \dots & 0 \\ \dots & \dots & \dots & \dots & \dots & \dots & \dots & \dots & \dots & \dots & \dots & \dots \\ 0 & a_d & \dots & a_a & a_c & 0 & \dots & 0 & 0 & a_e & \dots & 0 \\ 0 & 0 & \dots & a_b & a_a & a_c & \dots & 0 & 0 & 0 & \dots & 0 \\ \dots & \dots & \dots & \dots & \dots & \dots & \dots & \dots & \dots & \dots & \dots & \dots \\ 0 & 0 & \dots & 0 & 0 & 0 & \dots & 0 & 0 & 0 & \dots & 0 \\ 0 & 0 & \dots & 0 & 0 & 0 & \dots & 1 & 0 & 0 & \dots & 0 \\ 0 & 0 & \dots & 0 & 0 & 0 & \dots & 0 & a_a & a_c & \dots & 0 \\ \dots & \dots & \dots & \dots & \dots & \dots & \dots & \dots & \dots & \dots & \dots & \dots \\ 0 & 0 & \dots & 0 & 0 & 0 & \dots & 0 & a_b & a_a & \dots & 0 \\ 0 & 0 & \dots & 0 & 0 & 0 & \dots & 0 & 0 & 0 & \dots & 0 \\ 0 & 0 & \dots & 0 & 0 & 0 & \dots & 0 & 0 & 0 & \dots & 1 \end{bmatrix} * \begin{bmatrix} T_1^{new} \\ T_2^{new} \\ T_3^{new} \\ \dots \\ \dots \\ \dots \\ \dots \\ T_{end-1}^{new} \\ T_{end}^{new} \end{bmatrix} = \begin{bmatrix} T_{bcstart}^{old} \\ b_2 \\ b_3 \\ \dots \\ \dots \\ T_{bcright}^{old} \\ T_{bcleft}^{ne} \\ \dots \\ \dots \\ d_{end-1} \\ T_{bcend}^{old} \end{bmatrix} \quad (8)$$

Where a_a, a_b, a_c, a_d, a_e and b are temperature dependent material constants se equation 2a-e. T is temperature.

This space was built of evenly distributed spacing in the y and z direction respectively, y having 0.2mm spacing and z having 0.1mm. The initial layup was as seen in figure 2 with initially two materials; a layer of plastics (green) and a layer of air (blue). The entire simulation space was encapsulated with Dirichlet boundary conditions (faded colors) containing an increased thermal resistance to simulate convection like behaviors at these boundaries [Figure 2].

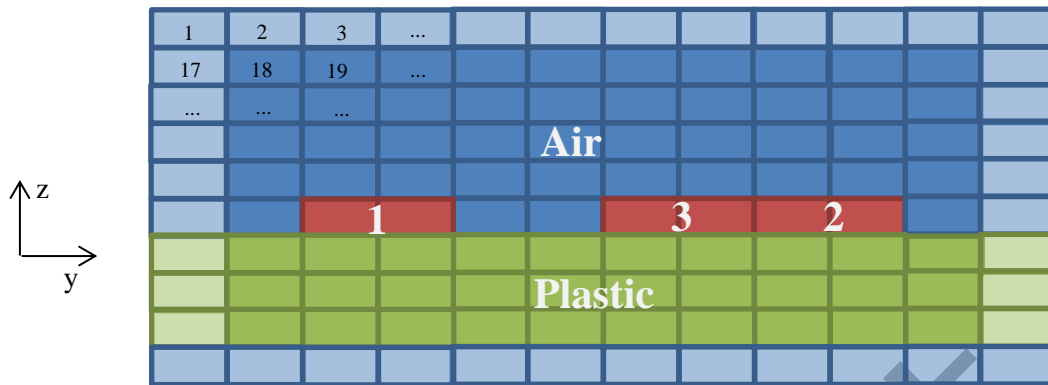

Figure 2: The 2D simulation space used for the thermoplastic simulation.

For the thermosetting experiments performed in this study, the simple deposition pathway only pass the sensor areas one time for each layer. This enables further simplifications of the 2D-model to a 1D model, so for the thermosetting experiments the simplified 1D model is used with the simulation space as seen in Figure 3.

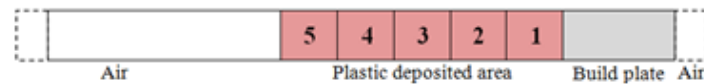

Figure 3: The 1D simulation space used for the thermosetting simulations, in here the dashed lines are dummy boundary control volumes.

The numbers shown in figure 2 and 3 indicate the sequence at which the material was added during the different simulations at time sequences specified by the g-code and the analyzing program.

Experiments

For the thermoplastic experiments an Ultimaker was used with DasyLab thermal measurement equipment at refresh rate 0.1s and k-type thermocouples. The thermocouples were integrated into an artificial ABS buildplate in the desired evaluation pattern see figure 4A, which was placed on the actual buildplate and then the bed was levelled according to this new printbed setup. For the printjob the process parameter settings in Cura were: Hot-end temperature; 250°C. Build plate temperature; switched off. Deposition dimensions; 0.4 mm: 0.1 mm (w: h), speed set according to experiment; 15-60mm/s (shown figures in this work are 15mm/s). After the experiments were performed, the raw data were extracted. The data gathered, while the printer was inactive, was discarded. The remaining data was adjusted to a baseline temperature, so that the different reading offsets were removed. After this procedure the results were added to the Matlab simulation coding for comparing results.

For the thermosetting experiments a homemade x, y, z board based on the Prusa i3 3D-printer design (Reprap, freeware community) was used. On it a static mixing tip (yellow 6mm, polo-dent) was attached which was connected to a homemade syringe pump (< 2ml/min) through Teflon tubing. The chemicals used, was a two component polyurethane system; Component A was Desmodur PF (Tradename, Covestro,

isocyanate mixture) and component B was Baygal 89-502 (Tradename, Covestro, polyol mixture). To increase the reactivity between these mixtures Bismuthneodecanoate (Bi-NDE, CAS: 34364-26-6, Sigma Aldrich, polyurethane catalyst) was added to component B (0.17vol %). The k-type thermocouples used for these experiments were taped on to the printed in the desired pattern see figure 4B and a Measurement Computing usb 5100 series data gather, refresh rate 1s, was used for collecting the thermal data. The data is treated in the same manner as during the thermoplastic experiments.

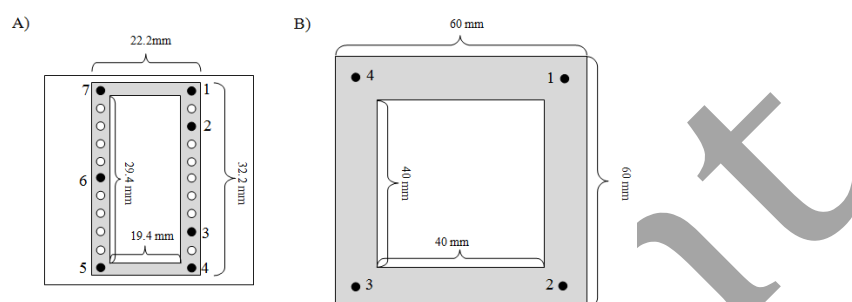

Figure 4: Schematic illustration of the test geometry used and the positions of the thermocouples applied in the two experimental cases: A) thermoplastic experiments, B) thermosetting experiments.

RESULTS AND DISCUSSION

Thermoplastic simulation

The thermal model of this study generally shows a good agreement between simulation and the performed thermoplastic experiments see figure 5, although a perfect coherence is not observed. One of the major issues leading to lacking coherence is a slight temperature overshoot performed by the simulation. This overshoot could indicate lacking knowledge of either; the constants used to describe the transition resistances of the model, or that the plastic thermal conductance, density and heat capacity are inaccurately determined. To correct this, different experiments could be made to increase the confidence in the different factors used in the model. This can be further investigated by different techniques such as, radiometric principles for the density measures and differential scanning calorimetry (DSC) for the heat capacity profiles. The thermal conductance could be measured by different axial flow methods or guarded hot plate experiments. The transition resistance is more difficult to measure, due to many experimental problems not always described by directly measurable factors i.e. specific roughness and connectivity in the interface layers. Furthermore the convective boundary conditions simulated by a Dirichlet dummy control volume and an arbitrary transition resistance, could give reason for speculations of the accuracy at the edges of the simulation space. Additionally, for this initial study material property experiments were not performed for the specific polymer system but gathered from comparable injection moulding materials in the commercial available software Autodesk Moldflow. All these factors introduce some uncertainty about the accuracy of the simulations, because e.g. different transition resistances of the model were fitted to the sparse experimental dataset of this study.

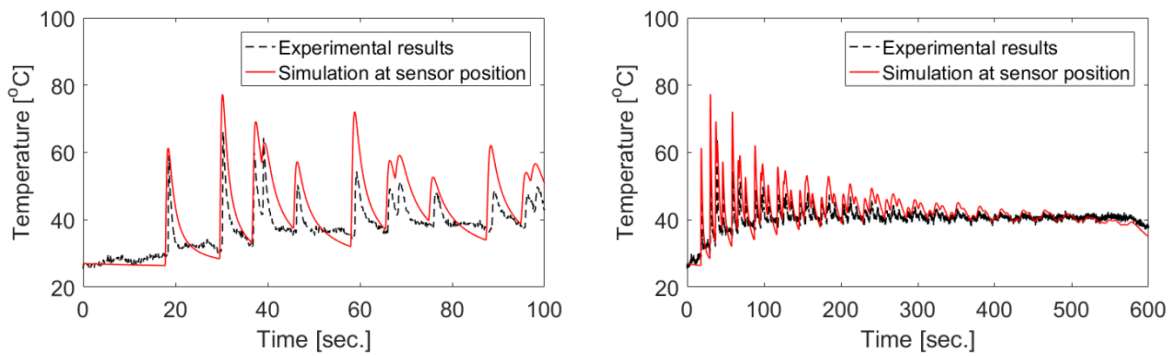

Figure 5: An example of a thermal experiment result and its coherent simulation.

The simple experimental setup introduced some additional uncertainties, which made the simulations for comparison difficult to perform. First of all the holes made to fit the thermocouples had a thickness of 2 mm whereas the thermo-couple diameter merely had an average diameter of 0.7mm making room for sensor rattling in the holes. Secondly the uneven welding of the different thermocouples could result in different response times and alter the thermal behaviour locally in the hole. Thirdly the placement of the manufactured ABS hole-plate happened manually without a guiding system in place, which provides fluctuations in the exact printing pattern in between experiments, resulting in inconsistent experiments. With deposition widths of only 0.4mm even small displacements of the experimental setup have large influence of the registered signals by the model indicating that further development of the experimental setup might be required. This development should be aimed towards a more consistent experimental setup with guide systems for plastic inserts, smaller holes drilled into the plastics and a more even thermocouple welding technique used. By doing this, the comparability between models and experiments could be increased and the mentioned causes for inconsistencies reduced. Even with all of these stated uncertainties and inconsistencies the model shows a fine coherency between the model and the experiments made during this study, highlighting the robustness of this modelling approach. With better material property knowledge the confidence level of the modelling approach could increase making this system applicable in a range of material extrusion based thermoplastic systems for a pre-process validation for quick iterations before making a final heavy computational simulation for the final process design.

Thermosetting simulation

To increase the model applicability to composite processes of thermosetting materials, the thermo-chemical reaction is now added to the model [equation 5-7]. This is done to account for the curing reaction happening during this process, whereas the thermoplastic AM process only deals with partly melting of the material and hence does not need this extra added term. The experimental setup for this simulation validation enable a simplified 1D model approach to describe the thermal propagation of the heat propagation, which is seen in figure 6a and 6b to lead to a generally good correlation between model and experiment. But as seen in the figures it is not a perfect correlation while some major problems are still influencing this process. One of the issues are the level of readiness of the thermosetting material extrusion AM processes, which results in difficulties to obtain high levels of experimental consistency see figure 6b. Among the major process issues resulting in poor consistency are consistent mixing of the material

and the catalyst in the material, but even with this high inconsistency a clear tendency is still seen when looking at the data; increase in catalytic amounts lead to increased temperature measurements. This observation is in good agreement with the exothermal nature of the polymerization reaction. From the simulation process of the thermosetting experiments it is seen that the different experiments can be described by changing primarily the activation energy in the Arrhenius term of the reaction kinetics, which corresponds to the influence of the catalyst in the PU system. The reaction kinetics and the thermal profiles, which have a significant influence on the reaction kinetics is important to understand, while the relationship between these factors are critical to material extrusions based thermosetting AM processes. This importance is stressed while too fast reactions can lead to increased thermal degradation and possibly increases warping within the material from the process. Furthermore the curing rate of the placed material must not exceed a certain threshold before the next layer is applied to secure interlayer adhesion, which makes this simulation tool valuable when trying to evaluate a thermosetting process and to secure good adhesion within the part from the planned pathway. The importance of a simulation tool to help the path planning of a thermosetting AM process is further shown in the complexities involved in the kinetics of the curing process which must be combined with the process movement patterns and volumetric flow, while keeping the flow of the material in check. The latter set up strict demands to the used material, while this process require materials able to reach the gel time fast to create a form-stable material to be deposited, while having a high final curing time to increase the process window and to ease the AM processing of the material. From all these added complexities when going from thermoplastic to thermosetting simulations the need for a good simulation tool would seem critical and even though this study has only scratched the surface of thermosetting simulation and printing the first indication might imply its usefulness.

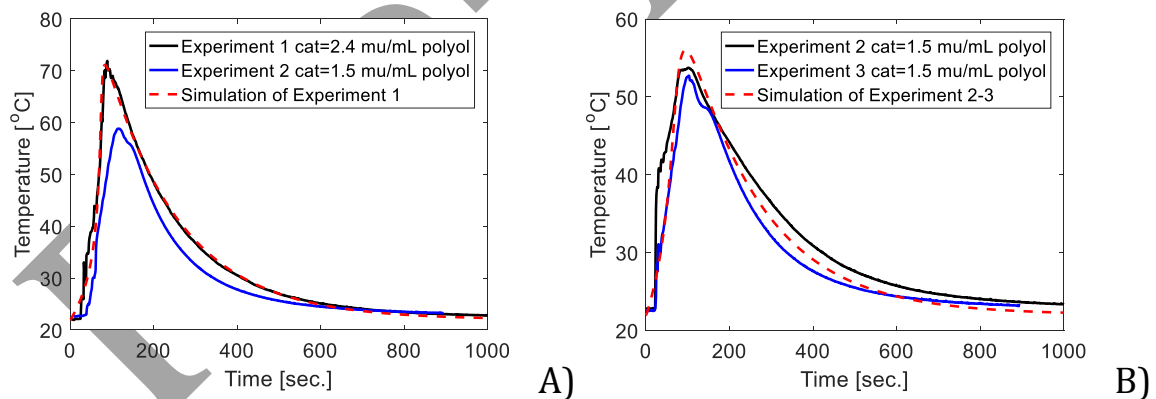

Figure 6: Experimental results of the thermosetting printing. A) Sensor 1 response to experiment 1 and 2, which received different amounts of catalytic content. B) Sensor 2 response to experiment 2 and 3, which show indications of the reproducibility of the method.

CONCLUSION

During this work a 2D-thermoplastic and a 1D-thermosetting transient heat conduction model with finite volume discretization were developed and tested up against experimental data. The comparison between the model and the experiments showed

descent coherence, indicating this simulation approach as being valid for thermal propagation during a material extrusion based AM process, although the developed simulation model was only an initial study. The models still need further experimental validation and an in-depth experimental investigation of material properties of the used materials within the different experiments, for better predicting the thermal behavior. This way the models could be used as a quick verification step of deposition pathways needed for new geometries, hence enabling rapid iterations of different setups at an increased pace. Hereby showing whether the proposed design, would be fit for AM processes and give an initial estimate on where the largest stresses and strains would be located in the part, and this could potentially remove the need for other expensive destructive validation tests.

ACKNOWLEDGEMENTS

The Authors would like to give out thanks to Aarhus University for borrowing their equipment for the thermos-setting experiments and for supplying the polyurethane precursor materials used for the thermosetting experiments. In addition thanks should be given to the Innovation Fund Denmark for their part in funding this research.

REFERENCES

- [1] "ISO / ASTM52900 - 15, Standard Terminology for Additive Manufacturing – General Principles – Terminology," ASTM International, West Conshohocken, PA, 2015.
- [2] Wohlers associates, "Wohlers report 2016; 3D printing and additive manufacturing state of the industry annual worldwide progress report," Wohlers associates, inc, Fort Collins, Colorado, 2016.
- [3] N. Keller and V. Ploshikhin, "New method for fast prediction of residual stress and distortion of AM parts," in *Solid Freeform Fabrication Symposium*, Austin, Texas, 2014.
- [4] A. Bellini, S. Güceri and M. Bertoldi, "Liquefier Dynamics in Fused Deposition," *Journal of Manufacturing Science and Engineering*, pp. 237-246, 2004.
- [5] R. S. Crockett and P. D. Calvert, "The liquid-to-solid transition in stereodeposition techniques".
- [6] N. Venkataraman, , S. Rangarajan, , M. J. Matthewson, B. Harper, , A. Safari, S. C. Danforth, G. Wu, N. Langrana, S. Gucerı and A. Yardimci, "Feedstock material property \pm process relationships in fused deposition of ceramics (FDC)," *Rapid Prototyping Journal*, pp. 244 - 253, 2000.
- [7] M. K. Agarwala, V. R. Jamalabad, N. A. Langrana, A. Safari, P. J. Whalen and S. C. Danforth, "Structural quality of parts processed by fused deposition," *Rapid Prototyping Journal*, pp. 4-19, 1996.
- [8] R. Anitha, S. Arunachalam and P. Radhakrishnan, "critical parameters influencing the qualities of prototypes in fused deposition modeling," *Journal of materials processing technology*, pp. 385-388, 2001.
- [9] A. K. Sood, R. K. Ohdar and S. S. Mahapatra, "Experimental investigation and empirical modelling of FDM process for compressive strength improvement," *Journal of Advanced Research*, pp. 81-90, 11 10 2011.

- [10] M. Nikzad, S. H. Masood, I. Sbarski and A. Groth, "A Study of Melt Flow Analysis of an ABS-Iron Composite in Fused Deposition Modelling Process," *TSINGHUA SCIENCE AND TECHNOLOGY*, pp. 29-37, 06 2009.
- [11] L. Ji and T. Zhou, "Finite Element Simulation of Temperature field in Fused Deposition modeling," *Advanced Materials Research*, pp. 2585-2588, 2010.
- [12] J. Martínez, J. L. Diéguez, E. Ares, A. Pereira, P. Hernández and J. A. Pérez, "Comparative between FEM models for FDM parts and their approach to a real mechanical behaviour," *Procedia Engineering*, p. 878 – 884, 2013.
- [13] M. Nikzad, S. H. Masood and I. Sbarski, "Thermo-mechanical properties of a highly filled polymeric composites for Fused Deposition Modeling," *Materials and Design*, p. 3448–3456, 29 01 2011.
- [14] M. R. Talagani, S. Dormohammadi, R. Dutton, C. Godines, H. Baid, F. Abdi, V. Kunc, B. Compton, S. Simunovic, C. Duty, L. Love, B. Post and C. Blue, "Numerical simulation of big area additive manufacturing (3D printing) of a full size car," *SAMPE*, vol. 51, no. 4, pp. 27-36, 2015.
- [15] Y. Zhang and Y. K. Chou, "Three-dimensional finite element analysis simulations of the fused deposition modelling process," *Proc. IMechE*, pp. 1663-1671, 2006.
- [16] D. Pal, N. Patil, K. Zeng and B. Stucker, "An Integrated Approach to Additive Manufacturing Simulations Using Physics Based, Coupled Multiscale Process Modeling," *Journal of Manufacturing Science and Engineering*, pp. 061022- 1-16, 2014.
- [17] J. Hattel, *Fundamentals of numerical modeling of casting processes*, Polyteknisk forlag (ISBN 8-7502-0969-8), Pages: 540, 2005.
- [18] A. T. Bogetti and W. J. Gillespie Jr., "Two-dimensional cure simulation of thick thermosetting composites," *Journal of composite materials*, pp. 239-273, 25 03 1991.
- [19] P. I. Karkanas and I. K. Partridge, "Cure modeling and monitoring of epoxy/amine resin systems. 1. Cure Kinetics modeling," *Journal of applied polymer science*, pp. 1419-1431, 2000.
- [20] P. Król, "Synthesis methods, chemical structures and phase structures of linear polyurethanes. Properties and applications of linear polyurethanes in polyurethane elastomers, copolymers and ionomers," *Progress in material science*, vol. 52, pp. 915-1015, 2007.