



Multicast Energy Aware Routing in Wireless Networks

Ahmad Karimi

*Department of Mathematics, Behbahan Khatam Alanbia University of Technology, Behbahan, Iran
karimi@bkatu.ac.ir*

ABSTRACT

Multicasting is a service for disseminating data to a group of hosts and it is of paramount importance in applications with a close collaboration of network hosts. Due to limited energy available in the wireless devices, energy management is one of the most important problems in wireless networks. Energy aware routing strategies help us to minimize the energy costs for communication as much as possible and to increase the network lifetime. In this paper, we address the problem of energy efficient routing to increase the lifetime of the network. We present three new strategies for online multicast energy aware routing in wireless networks to increase the network lifetime.

Keywords: Network lifetime, Multicast routing, Wireless networks.

1. INTRODUCTION

As wireless networks usually face limitations in energy availability, energy management is of paramount importance in such networks. In order to increase the network lifetime, we apply energy aware strategies. Energy aware routing strategies typically compute the shortest cost path, where the cost associated with each link is some function of the transmission energy associated with the corresponding nodes [1]. Usually, network lifetime is defined as the number of packets can be transferred between source and destination nodes in the network before they get disconnected [2, 3, 4]. In this paper, we aim to do multicast routing from a source node to a group of destination nodes and our main goal is to maximize network lifetime. We model our wireless network with a graph $G = (V, E)$ in which, V is the set of wireless devices and E is the set of edges between such nodes that they are in direct communication range of each other. We introduce the energy graph $EG = (V, E')$ which helps us to compute maximum residual energy of the network. We propose three new algorithms for multicast routing, called “Multicast Shortest Widest Path (MSWP)”, “Multicast Shortest Fixed Width Path (MSFWP)” and “Multicast Shortest Width Constrained Path (MSWCP)”. Based on the nature of these algorithms, we obtain the optimal paths (between source node and destinations) which have sufficient width and they are the best in less energy consuming. The new methods are implemented on different topologies to show the performance of our algorithms in wireless networks.

2. NETWORK MODEL AND RESIDUAL ENERGY GRAPH

In this section, we want to model our wireless networks with graphs and present a definition of residual energy graph and also compute maximum residual energy of

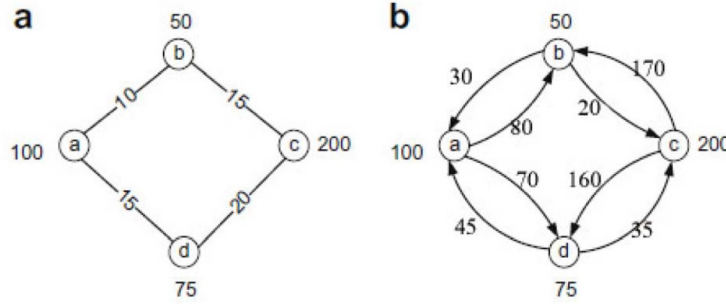

FIGURE 1. (a) A graph showing energy levels at nodes and energy required to transmit at each edge. (b) The corresponding energy graph.

the network. We model the wireless network with a graph $G = (V, E)$ in which, V is the set of nodes and E is the set of edges. Nodes v_i and v_j are connected via edge $e(v_i, v_j)$ if they are within radio transmission range of each other. Let r be the transmission radius which is determined by characteristics of the network and let d_{ij} be the Euclidean distance between the two nodes v_i and v_j , then edge $e(v_i, v_j)$ exists if and only if $d_{ij} \leq r$. We denote the available energy at node u by $w(u)$ and the required energy to transmit a packet from node u to node v by $w(u, v)$. Indeed, $w(u)$ is the battery amount available in the wireless device u and $w(u, v)$ is the cost of data transmission from the device u to the device v along the edge $e(u, v)$. In order to propose our strategies of routing, we consider a simple network as Figure 1. First, we construct the energy graph $EG = (V, E')$ by replacing each single undirected edge in G with two directed edges [2, 5]. EG is a weighted graph in which the weight of a directional edge in EG is equal to difference between the originating node's energy level and the multicasting transmission cost. Indeed, for two nodes u and v , the weight of directed edge from u to v in EG is $w_{EG}(u, v) := w(u) - \alpha w(u, v)$ where α is the multicasting factor. Figure 1(a) shows an example of wireless network and Figure 1(b) shows the corresponding energy graph.

Suppose that we plan to send data from source node $s = node(a)$ to destination nodes $t_1 = node(c)$ and $t_2 = node(d)$, concurrently. Let S be the set of all source nodes and $T = \{t_1, t_2\}$ be the set of all destination nodes that we decide to send data between them. Let $P(s, t)$ is a path between node s and one of destination nodes $t = t_1$ or $t = t_2$. For a path $P(s, t) = sv_i v_{i+1} \dots v_j t$ in the network, the residual energy denoted by $r(P(s, t))$, is defined as:

$$r(P(s, t)) := \min_{(v_k, v_l) \in P} (c(v_k, v_l)), \quad (1)$$

where $c(v_k, v_l) := w_{EG}(v_k, v_l) = w(v_k) - 2w(v_k, v_l)$ and $w(v_k)$ is the available energy in node v_k and $w(v_k, v_l)$ is the energy required to transmit a packet from node v_k to node v_l . We call $c(v_k, v_l)$ the residual energy of the edge $e(v_k, v_l)$. The maximum residual energy path between nodes s and t can be defined as:

$$Mr(s, t) := \max_{P \text{ is path from } s \text{ to } t} r(P(s, t)). \quad (2)$$

Finally, given a network $G = (V, E)$, we define the maximum residual energy graph as

$$Mr(G) := \min_{s \in S, t \in T} Mr(s, t). \quad (3)$$

Given a network G , we first construct the corresponding energy graph explained above. Then for all pairs (s, t) that $s \in S$ is a source node and $t \in T$ is a destination node, we compute maximum residual energy path $Mr(s, t)$ and $Mr(G)$. Eliminating of the edges that have residual energy $w_{EG}(v_k, v_l)$ less than $Mr(G)$, we construct the Pruning Maximum Residual Energy Graph (PMREG). In Figure 2, we see the PMREG corresponding to the origin graph G that was shown in Figure 1.

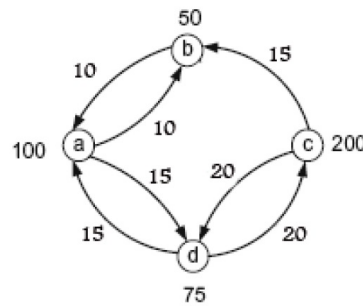

FIGURE 2. Pruning Maximum Residual Energy Network (PMREG) corresponding to graph G

3. MULTICAST ENERGY AWARE ROUTING

For every nodes $s \in S$ and $t_1, t_2 \in T$, we define a two-phase optimization problem:

- Multicast maximum residual energy path problem: find paths $P(s, t_1)$ and $P(s, t_2)$ with maximum $r(P(s, t_1))$ and $r(P(s, t_2))$, respectively.
- Multicast minimum energy path problem: find paths $P(s, t_1)$ from s to t_1 and $P(s, t_2)$ from s to t_2 with the minimum $e(P(s, t_1)) = \sum_{(v_k, v_l) \in P(s, t_1)} w(v_k, v_l)$ and $e(P(s, t_2)) = \sum_{(v_k, v_l) \in P(s, t_2)} w(v_k, v_l)$, respectively.

In this section, in order to multicast energy aware routing in the wireless network G , we apply multicast maximum residual energy algorithm presented in section 2. to obtain corresponding PMREG. This phase returns paths $P(s, t_1)$ and $P(s, t_2)$ from source node s to t_1 and t_2 whose residual energy will be the maximum in the network. Then we use the PMREG with edge weights $w(u, v)$ on it and handle the Dijkstra algorithm to find an optimal path between s and t_1 and also an optimal path between s and t_2 , simultaneously which have the lowest energy consumptions. In the first phase, we apply the Dijkstra algorithm [6] which returns paths from s to all nodes whose residual energy will be the maximum in the network [4].

Applying the algorithm in the first phase, we find paths with maximum residual energy from the source node s to the destination nodes t_1 and t_2 . For the Phase, we first compute the $Mr(G) = \min\{Mr(s, t_1), Mr(s, t_2)\}$ where $Mr(s, t_1)$ and $Mr(s, t_2)$ are the amount of maximum residual energy of two obtained paths via maximum residual energy algorithm. Then we prune the graph EG by elimination of all edges

that their residual energy are less than $Mr(G)$. Then, we label all remained edges by their cost weights that they consume energy to transmit data through themselves. Finally, we apply the Dijkstra algorithm to obtain paths with minimum energy consuming from s to t_1 and from s to t_2 . We call this algorithm “Multicast Shortest Widest Path (MSWP)”.

4. DERIVATIVES OF MSWP

In this section, the same as in [4], we propose two derivatives of MSWP. In both new algorithms, we first select a certain cutoff value to prune off all edges in the corresponding energy graph that have residual energy levels less than this cutoff value. Then we try to find paths with the minimum energy on the pruned subgraph. Selection of the cutoff values is the difference between MSWP and these two new algorithms.

In the first derivative of MSWP, we consider paths with a little bit less residual energy (instead of maximum residual energy) but more optimal in energy consuming. This routing algorithm is called “Multicast Shortest Width Constrained Path (MSWCP)”. We define a constraint on the width (residual energy) to be a certain fraction of the maximum possible residual energy for the given source and destinations pair in the multicast group [4].

The second derivative of MSWP that we propose, is called “Multicast Shortest Fixed Width Path (MSFWP)”. In this algorithm we fix the width (residual energy) of the paths at a certain value and prune the edges that their residual energy are below this fixed value. We continue finding the minimum energy paths on the pruned graph until we are not able to find a path for the given width. In order to find more nearly optimal paths we decrease the width, until the source and destination get disconnected. For example, let consider the widest paths from s to destinations t_1 and t_2 have the residual energy of 100 and 120, respectively. We fix our width on a fraction of the minimum of these two values, namely 80. Now, we prune all edges in the energy graph EG that their widths are below 80, and keep finding the minimum energy path until we are not able to find a path for the width 80. Then, we change the fixed width to 60 and repeat the process.

5. CONCURRENT ENERGY AWARE ROUTING

Our main goal in this section is to extend our work of multicast routing to concurrent energy aware routing in wireless networks. We are going to transmit data from source node s_1 to destination node t_1 and from the other source node s_2 to the destination node t_2 , simultaneously. To this end, we propose a similar algorithm to find optimal paths between s_1 and t_1 and also between s_2 and t_2 , concurrently. We introduce three concurrent energy aware routing algorithms called “Concurrent Shortest Widest Path (CSWP)”, “Concurrent Shortest Fixed Width Path (CSFWP)”, and “Concurrent Shortest Width Constrained Path (CSWCP)”. Given a graph G , we first construct the corresponding energy graph the same as in section 2. and for every nodes $s_1, s_2 \in S$ and $t_1, t_2 \in T$, we define two-phase problem:

- Phase I: Concurrent maximum residual energy path problem: find paths $P(s_1, t_1)$ and $P(s_2, t_2)$ with maximum $r(P(s_1, t_1))$ and $r(P(s_2, t_2))$, respectively.

- Phase II: Concurrent minimum energy path problem: simultaneously find paths $P(s_1, t_1)$ from s_1 to t_1 and $P(s_2, t_2)$ from s_2 to t_2 with minimum $e(P(s_1, t_1)) = \sum_{(v_k, v_l) \in P(s_1, t_1)} w(v_k, v_l)$ and $e(P(s_2, t_2)) = \sum_{(v_k, v_l) \in P(s_2, t_2)} w(v_k, v_l)$, respectively.

Our algorithm for the concurrent energy aware routing works as the same as multicast energy aware routing proposed in section 3., i.e., we apply a variant of the maximum residual energy algorithm which returns paths from s_1 and s_2 to all nodes in the network with maximum residual energy. Then, we compute the $Mr(G) = \min\{Mr(s_1, t_1), Mr(s_2, t_2)\}$ and eliminate all edges with residual energy below $Mr(G)$ to obtain the pruned graph of EG . Finally, we label all remained edges by their energy costs and apply the Dijkstra algorithm to obtain paths with the minimum energy consuming from s_1 to t_1 and from s_2 to t_2 . Note that, our approach to construct energy graph EG insures all nodes which are used by the Dijkstra algorithm have sufficient energy to send data concurrently through these optimal paths.

6. SIMULATION RESULTS

In this section, we implement our three algorithms on general topologies in MATLAB environment. Our experimental setup consists of two-dimensional grids of size 25×25 in which 50 nodes are spread, randomly. All nodes in the network have an initial residual energy $\sigma = 30$. We add edges to the network if the nodes are within each others' transmission range, i.e., $d_{ij} \leq r_T$, where r_T is the transmission radius. The energy cost of transmitting a single packet is calculated as $0.001 * d^3$ where d is the Euclidean distance between the nodes. We select source-destination pairs randomly to transmit packets between them. In the multicast routing, we aim to send data from a source node s to a group of destination nodes. We set the transmission radius to be 8, and we transmit only one packet through each routing, i.e., the session length is 1. We use different random topologies for our network and different multicast request sequences for each of such random topologies. During execution of the algorithm, we choose the next request randomly until network disconnection. As explained before, the lifetime of the network is calculated as the total number of packets which can be transmitted in the network before the network get disconnected. We report the average value of 10 runs as the output of our algorithm. The remained energy of network is computed as the average of energy of nodes in the network at the time of first session failure.

Figure 3 (top) shows the impact of the transmission radius on the lifetime and energy levels of the network which states superiority of MSWCP over other algorithms. We also evaluated the performance of the algorithms for the node densities 50, 75 and 100. The results are presented in Figure 3 (bottom). We see again that the MSWCP is generally outperforming other algorithms.

Figure 4 (top) and (bottom) is the simulation result of our proposed concurrent energy aware algorithms. It shows the impact of the transmission radius on the lifetime and energy levels of the network. We see superiority of CSWCP over other algorithms. Performance evaluation of the algorithms for the node densities 50, 75 and 100, shows the high performance of CSWCP in comparison to the other algorithms.

Multicast Energy Aware Routing in Wireless Networks

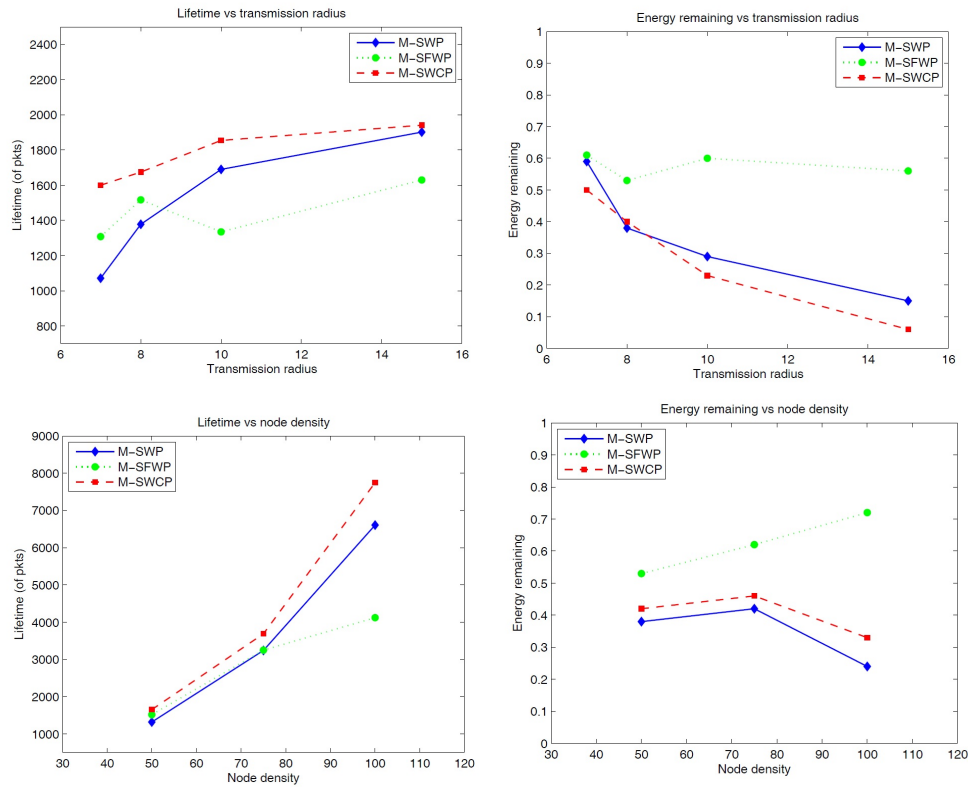

FIGURE 3. Simulation results of multicast energy aware routing

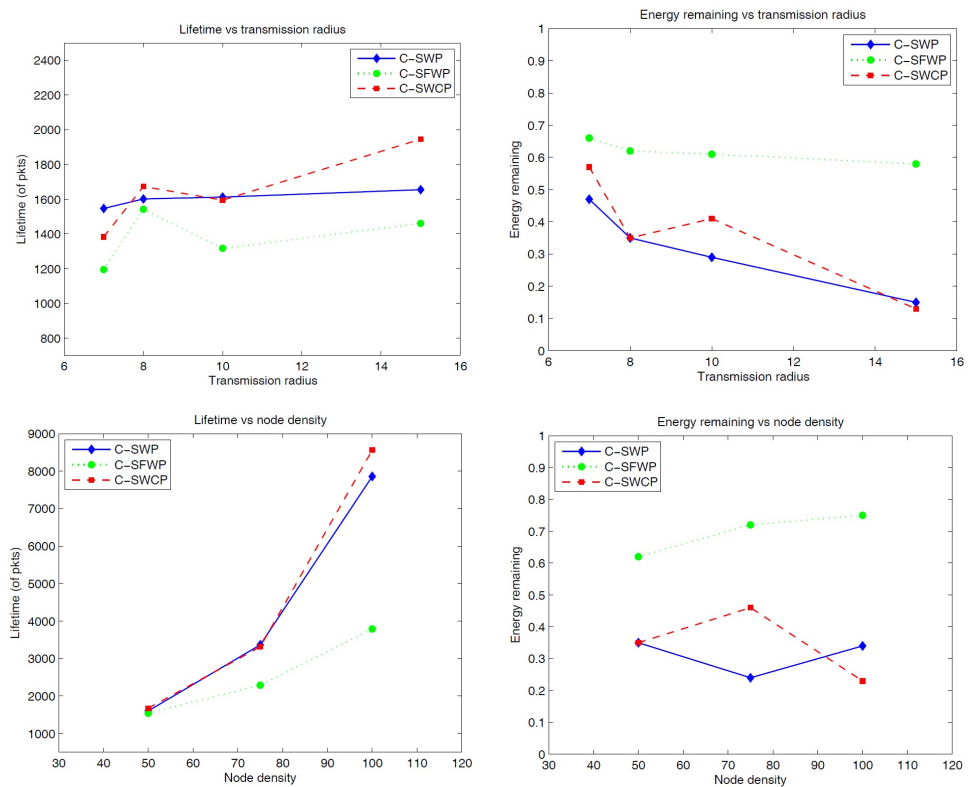

FIGURE 4. Simulation results of concurrent energy aware routing

7. CONCLUSION

In many network problems, we have models in which data transmissions are from one node to a group of nodes in the network, concurrently. So, multicast models are more important and applicable for us. Multicast energy aware routing decreases costs of wireless communications between devices and increases network lifetime. Applying two-phase strategies presented in this paper, we send messages from source node s to a group of destinations through the paths with maximum residual energy and minimum energy consumption. The energy aware strategies provide us a longer network lifetime as well as the ability of managing the energy of wireless devices in vital environments.

REFERENCES

- [1] S. Banerjee, A. Misra, *Minimum energy paths for reliable communication in multi-hop wireless networks*, Proc. MobiHoc, June 2002.
- [2] Q. Li, J. Aslam, D. Rus, *Online power aware routing in wireless ad-hoc networks*, in: Proceeding of 7th Annual International Conference on Mobile Computing and Networking, 2001, pp. 97–107.
- [3] M.R. Minhas, S. Gopalakrishnan, V.C.M. Leung, *An online multipath routing algorithm for maximizing lifetime in wireless sensor networks*, in Proc. ITNG 2009, pp. 581–586.
- [4] A.B. Mohanoor, S. Radhakrishnan, V. Sarangan, *Online energy aware routing in wireless networks*, Ad Hoc Networks 7 , 2009 , pp. 918–931.
- [5] J. Park, S. Sahni, *An online heuristic for maximum lifetime routing in wireless sensor networks*, IEEE Transactions on Computers, 55 (8), 2006, pp. 1048–1056.
- [6] R.K. Ahuja, T.L. Magnanti, J.B. Orlin, *Network Flows: Theory, Algorithms, and Applications*, Prentice Hall, 1993.