

# **Selection of Line Contingency for Power system Security Analysis**

*A Thesis submitted in partial fulfilments of requirement to the  
National Institute of Technology Rourkela*

*for the dual degree of*

***Bachelor of Technology***

*in*

***Electrical Engineering***

*and*

***Master of Technology***

*In*

***Control and Automation Engineering***

*By*

**Kamlesh Kumar Gahir**

Roll No: 711EE3152

Under the supervision of

**Prof. Ananyo Sengupta**



May, 2016

Department of Electrical Engineering

**National Institute Of Technology, Rourkela**



Department of Electrical Engineering  
**National Institute Of Technology Rourkela**

---

May 2016

## Certificate of Examination

Roll Number: 711EE3152

Name: Kamlesh Kumar Gahir

Title of Thesis: Selection of line contingency for power system security analysis

We the below signed, after checking the thesis mentioned above and the official record book (s) of the student, hereby state our approval of the dissertation submitted in partial fulfillment of the requirements for the dual degree of Bachelor of Technology in Electrical Engineering and Master of Technology in Control and Automation at National Institute of Technology Rourkela. We are satisfied with the volume, quality, correctness, and originality of the work.

*Professor Ananyo Sengupta*

Principal Supervisor

*<Name of Examiner>*

Examiner



Department of Electrical Engineering  
**National Institute Of Technology Rourkela**

---

**Prof. Ananyo Sengupta**

Assistant Professor

May 2016

## Supervisor's Certificate

This is to certify that the thesis entitled, “**Selection of Line Contingency for Power System Security analysis**” submitted by **Kamlesh Kumar Gahir** in partial fulfilment of the requirements for the award of dual degree of **Bachelor of Technology in Electrical Engineering** and **Master of Technology in Control and Automation Engineering** during 2014-2016 at the National Institute of Technology Rourkela is an authentic work carried out by him under my supervision and guidance. Neither this thesis nor any part of it has been submitted for any degree or diploma to any institute or university in India or abroad.

---

*Ananyo Sengupta*

*Dedicated to*  
*My beloved family,*  
*My generous teachers,*  
*My sincere friends.*

# Declaration of Originality

I, Kamlesh Kuamr Gahir, Roll Number 711EE3152 hereby declare that this thesis entitled “*Selection of Line Contingency for Power Syetem Security analysis*” represents my original work carried out as a postgraduate student of NIT Rourkela and, to the best of my knowledge, it comprises no material previously published or written by another person, nor any material presented for the award of any other degree or diploma of NIT Rourkela or any other institution. Any contribution made to this research by others, with whom I have worked at NIT Rourkela or elsewhere, is explicitly acknowledged in the dissertation. Works of other authors cited in this dissertation have been duly acknowledged under the section "Reference". I have also submitted my original research records to the scrutiny committee for evaluation of my dissertation.

I am fully aware that in the case of any non-compliance detected in future, the Senate of NIT Rourkela may withdraw the degree awarded to me on the basis of the present thesis.

May 2016

Kamlesh Kumar Gahir

NIT Rourkela

# Acknowledgement

My most recent five years venture at **National Institute of Technology, Rourkela** has added significant and valuable experiences to my life. I have utmost regard and adoration for this institute, and I shall always remember the individuals who have made this environment so exceptional and extraordinary. Now it is time to proceed onward to my future. Before I go any further, I like to express my sincere gratitude to those who have assisted me along the way.

First and foremost, praise and heartfelt thanks go to the Almighty for the blessing that has been showered upon me in all my endeavors.

I would like to express my heartfelt gratitude to **Prof. Ananyo Sengupta** for his help and contribution. I am also thankful to all the faculty members of Electrical Engineering dept. specially faculty of Control and Automation group.

It gives me immense pleasure to acknowledge my all of my dual degree batchmates for helping me in completion of the project.

May 2016

Kamlesh Kumar Gahir

NIT Rourkela

# **Abstract**

Contingency analysis (CA) has always been an integral part of power system security analysis. CA is a useful tool at disposal of operation personnel to see effects of future outages on the system. The overload Performance Index (PI) is a good index for ranking the contingencies as per their severity. The PI requires “n” number of DC analysis to create a complete index, where n is no of lines. And for a larger network having a higher multitude of lines, it is time consuming. A new approach has been discussed for ranking the contingencies. This method requires one DC analysis and line outage distribution factor, which is constant for a particular unchanged transmission network.

***Keywords: Contingency analysis, Performance index, Line sensitivity factor, Power system security.***

## Table of Contents

Certificate of Examination .....	i
Supervisor's Certificate .....	ii
Declaration of Originality .....	iv
Acknowledgement .....	v
Abstract .....	vi
List of abbreviation .....	ix
<i>Chapter 1</i> INTRODUCTION .....	1
1.1 Introduction .....	1
1.2 Literature Review .....	3
1.3 Motivation .....	4
1.4 Objective .....	4
<i>Chapter 2</i> CONTINGENCY ANALYSIS .....	5
2.1 Introduction .....	5
2.2 Contingency Analysis .....	5
2.2.1 Low voltage Violation .....	6
2.2.2 Line MVA limits violations.....	7
2.3 Use of CA as a tool .....	7
2.4 Power Flow solution.....	8
2.4.1 SLACK BUS: .....	9
2.4.2 LOAD BUSES:.....	9
2.4.3 P-V BUSES: .....	9
2.5 Fast Decoupled Power Flow Solution:.....	10
2.5.1 Fast Decoupled Load Flow Algorithm [4] .....	11
2.6 AC power flow method of contingency analysis .....	13
2.7 Performance index.....	14
<i>Chapter 3</i> A NEW METHOD FOR LINE CONINGENCY RANKING.....	15
3.1 Introduction .....	15
3.2 Line outage distribution factor .....	15
3.2.1 Calculation of line outage distribution factor .....	16



3.3 New method for line contingency selection .....	20
3.4 Using $P_{eff,k}$ in contingency selection/screening:.....	21
<i>Chapter 4 RESULTS AND DISCUSSION</i> .....	23
4.1 Introduction .....	23
4.2 IEEE 9 bus system.....	23
4.3 6 bus system .....	26
4.4 Discussion .....	30
<i>Chapter 5 CONCLUSION &amp; FUTURE SCOPE</i> .....	31
5.1 Conclusion.....	31
5.2 Future Scope.....	31
Bibliography .....	32
Appendix.....	33
A) IEEE 9 Bus system.....	33
A.1 IEEE 9 Bus system Figure .....	33
A.2 IEEE 9 bus Data sheet .....	34
B) 6 Bus System.....	36
B.1 6 Bus system figure.....	36
B.2 Data sheet.....	37

## List of abbreviation

MVA	mega volt ampere
MW	mega watt
PI	performance index
LODF	line outage distribution factor
p.u	per unit
$G_{ij}$	conductance between bus i and j
$B_{ij}$	suseptance between bus i and j
$\theta_i$	phase angle at bus i
$V_i$	voltage magnitude at bus i
$P_i$	real power injection at bus i
$P_i^s$	real power specified at bus i
$Q_i$	reactive power at bus i
$Q_i^s$	reactive power specified at bus i
$S_{ik}$	complex power flow on bus I and k
$d_{l,k}$	line outage distribution factor while monitoring line l with line k out
$\Delta f_l$	change in the MW flow on line l
$f_k^0$	MW flow on line “k” before it was outaged
$X_k$	reactance of line k
$P_{eff,k}$	effective change in MW flow on all the lines taken together when line k is out

# **Chapter 1 INTRODUCTION**

## **1.1 Introduction**

Power generation and transmission together form a very complex network and called electric power system. Its primary purpose is to provide electrical power in an uninterrupted fashion to the customer ends and that also within particular set limits of voltage and frequency. No doubt with the exploitation of electric power system the problem of voltage stability and voltage collapse calls for profound attention.

Power System Security is characterized as the capacity of the power system to stay secure without any serious disturbance in the system to any pre-selected credible contingencies. The most well-known operational issues are transmission line overloads and low voltage violation at system buses. The procedure of distinguishing, whether the system is operating in the secure or insecure state, is called power system security analysis. The secure state suggests that the system working under prescribed voltage limit and transmission line violation is absent and within the sight of unforeseen contingencies. In the wake of any violation of any security related inequality pushes the system to an insecure state, thereby remedial actions to be taken to get the system back to secure state.

At any point in time, it is highly unlikely that the power system would be totally or completely secure. And it is very much possible that any particular chain of events can lead to total or partial failure of the system. Single contingencies are more observed than multiple contingencies. Power system security represents an essential issue in planning and operation of a power system. Security analysis, fundamentally, manages to assess the capacity of the system to keep on providing uninterrupted power in case of an unforeseen contingency. Routine strategy for security assessment includes comprehending full AC load flow studies along with transient stability analysis.

In planning, design and operation stages of any electric power systems security analysis is a major factor. Security analysis comprises three aspects i.e. static, transient and dynamic. The traditional

method of static security analysis involves the solution of full AC load flow equations for each and every contingency, which is highly time-consuming and not practical for real-time applications. Security assessment should analyze whether, and to what extent, the system is practically safe from severe interference to its operation. So if system security analysis is not put into assessment beforehand then any occurrence of certain severe interference or disturbance may lead the system to go to an undesirable emergency state. Therefore, for the effectiveness of the control of power system, quickness in security evaluation of their operating states are required. And it is seen that the conventional method falls short on the front that it uses a lot of computer resources and also takes a long time which is inadequate for real-time application.

As discussed earlier Security assessment should analyze whether, and to what extent, the system is practically safe from severe interference to its operation. The system operator's job involves maintaining the system in a normal state and to take immediate control actions in the wake of any severe disturbances that may cause the system to get into emergency state. Post application of the control action the system should operate in normal state. Therefore, the effectiveness of control of power systems suggests quickness in security evaluation of their operating states.

In this thesis, we have dealt with the Line MVA limit violation or Line contingency. Line contingency occurs whenever the line MVA rating exceeds a given rating. One way to design credible line contingencies of an electric power system is to take one line out or modeling a line outage and then studying its effects on the other lines of the system. Then we would like to know how much a particular line outage might affect the whole power system and for that we can use Performance Index [2]. Then ranking PIs of the line outages would give us a particular idea how a particular contingency is more severe than other contingencies i.e. the largest valued PI is most disturbing of them all. But calculation of these PIs takes time as well as considerable computer resources if the system is vast comprising of hundreds of buses and transmission lines. An alternative method or some other index from where the operation personnel can know how much a particular line contingency is affecting the system and that too in a quicker fashion can be handy at the personnel end to allow them for monitoring and reliable operation. Line outage distribution factor (LODF) [2] is used to derive a new Index which is faster to calculate and requires only the values obtain after a complete AC load flow analysis of the system at normal state.

## 1.2 Literature Review

For the past several years digital computers are being used for the power-flow or load-flow studies and this can be attributed to the high-speed processing of these. Basically they assist the operator or personnel in evaluating real time performance of the system and formation of planes for system improvement. These computers can very efficiently study different cases without any intervention in between them. Nowadays contingency analysis (CA) plays an important role in energy management system. CA is one of the major aspect in the planning and operation of power system. It provides the personnel tools which can be employed for the managing, creating, analyzing and reporting lists of contingencies and related violations [5]. The CA is being used as both off line and on line tool for analyzing the contingency events and to provide with a tool for operators to show effects of future outages.

As the increment of load demand is inevitable and to meet this demand the present systems are lacking proper investments in its generation and transmission. Which in turn have affected the stability, so a more reliable and faster tool is required [2, 6, 7].

For faster estimation of system stability just after a certain outage the CA involves efficient calculation of system performance from a set system conditions. Computer program has been developed for testing the performance of a particular power system in presence of line and transformer contingencies [1] which is based on the specified maximum capacity of the line and transformer.

The traditional approach of steady-state contingency analysis requires testing of all contingencies sequentially to evaluate system's operation and reliability [8]. This requires simulation of outages of one or more transmission lines to study their effects and for this purpose various fast computational techniques are being used such as Stott's Fast Decoupled load flow [5]. Since exhaustive contingency analysis becomes impractical due to its long running time an alternative method for selecting line contingencies has been given in this paper. According to the new method all credible line contingencies are ranked so if a contingency happened in real time we can know the severity of that. If it is among the top cases then we can employ a full AC load flow analysis

for complete assessment of the system. Since a full AC load flow analysis is time consuming for a larger system we should use it judiciously.

### **1.3 Motivation**

Day by day in the world the consumption of electric power is increasing so the main objective of the provider has always been to deliver consumer uninterrupted power in economical and reliable ways. A single line outage pushes the transmission circuits of the system to take up the flow on the line (outage line) which is now opened. And if one of the line gets opened due to relay operation due to heavy loading, thereby causing even more load on the remaining lines and causing a cascading outage. Most of the system are designed with much redundancy in its transmission network to avoid cascading failure but due to the presence of large possible system conditions a new contingency selection index might be handy at the operation personnel end and it can also be used in pre-screening of all single line outage contingency of a system.

### **1.4 Objective**

The objective of the thesis are:

- a. To design a faster method to rank all possible single line contingencies of a given system.

## **Chapter 2 CONTINGENCY ANALYSIS**

### **2.1 Introduction**

One of the major aspect in today's Energy Management System (EMS) is contingency analysis. The purpose of contingency analysis or simply CA is to identify overloads and problems which may arise due to any contingency.

### **2.2 Contingency Analysis**

Modern day power system is made of up a large number of electrical equipment and any failure of these may lead the system to failure by pushing the system parameters beyond its operating point. Thus there will be an obstruction in its secure operation and reliability also suffer. For the power system to operate securely it is imperative that no limit is violated like bus voltage and line MVA flow and if not there will be blackouts or equipment damage.

“Contingency” means any unpredictable events in a power system and this can lead the system to instability or total failure also. It affects the system's security, reliability and continuity. A temporary suspension of the power can be referred as an outage. While contingencies also refer to an outages or circumstances which are possible in a given system but cannot be predicted with confidence. And contingency analysis (CA) is the study of the system conditions by modeling different possible outages like generator, transformer or line outages.

The power engineer are responsible for efficient, cost effective and efficient power dispatch to the consumer's end and that too in an uninterrupted method. But the ever growing demand and rapid growing of the network pose a great challenge for the engineers.

At a power utility control center CA is used as a security analysis application. Its purpose is to assess the power system in order to identify any possible violation or overloading which can arise in wake of any contingency. Basically CA is an abnormal condition in the power system which put the whole network under pressure. It may occur due to sudden outage of a transmission link or line, generator outage, sudden change of load demand.

CA is proved to be a good study tool for the operation personnel due to its ability to use both as an off line and as an on line tool. As an off line tool to study various system characteristics for various contingencies and as an on line tool to help the operator to know effects of future outages.

- System security can be determined by the capability of the system to withstand credible contingencies.
- The weak elements of the system are those which can present further overload in the system in wake of a certain contingency.
- The standard approach for CA simulation is to perform or model outage taking one line out.
- Then ranking is done on basis of severity of all the CA simulation.
- CA is therefore used as a basic tool for maintenance plans and the corresponding outage schedules.

CA consists of simulation of the outages and investigation of the change on the system's steady state operating characteristics like bus voltages, line power flows. Various computational techniques like Fast Decoupled Load Flow [8] is used in it. There are mainly two types of contingencies more pronounced in power generation or transmission system i.e. Line contingency and Generator contingency. These contingency mainly causes two types of system violations.

### 2.2.1 Low voltage Violation

This is basically seen at the buses when the voltage at any bus is less than the specified voltage level. Generally the operating voltage of buses ranges from 0.95 p.u. to 1.05 p.u. until and unless mentioned otherwise. So if any bus voltage falls below the 0.95 p.u. mark or the specified limit it is said that the bus has a low voltage. And if it is above the 1.05 p.u. mark or the specified limit the bus is said to have a high voltage problem. It is realized that in the power system network large reactive power is the actual reason behind the voltage issues. Thus on account of low voltage issues reactive power is supplied to the bus to build the voltage profile at the bus. In the instance of the high voltage reactive power is injected at the busses to keep up the system normal voltage.



### 2.2.2 Line MVA limits violations

This kind of possibility happens in the system when the MVA rating of the line surpasses given rating. This is for the most part because of the expansion in the increment in current's amplitude in that line. The lines are planned in a manner that they should have the capacity to withstand 150% of their MVA limit. In view of utility practices, if the current crosses the 80-90 % of the limit, it is declared as an alarm situation.

### 2.3 Use of CA as a tool

In any security assessment of a power system CA is one of the prominent issue and since infrastructure is getting more complex with little or no extensive development in electric power station, more increment in demand cannot be handled by the system. Since system is expanding day by day it is required that contingency analysis should be effective.

The contingency analysis involves simulation of the individual contingency for a given power system. The contingency analysis comprises of three steps. There as follows:

1) Contingency creation: The first stage of the analysis. It comprises of all contingencies viable to occur in a power system. The process make a list of all possible contingency at the end of it execution.

2) Contingency selection: In this second stage of contingency analysis selection of the severe contingencies make it to a list. The list shows those contingencies which can lead to line MVA and bus voltage violation. The list is minimized by eliminating the cases which are less severe and only emphasizing on the most severe cases. After this by help of any of the index calculation the ranking of the cases are done.

3) Contingency evaluation: The third step involves the most important aspect as this involves necessary control actions and necessary security action to be taken in order to mitigate effects of the most severe case of the list for a given power system.

The method used is Performance index (PI) for the quantifying the severity and ranking those contingencies in the order severity.

Various iterative methods can be employed for calculation the performance indexes.

## **2.4 Power Flow solution**

For the control a planning operation of a power system Power flow studies are required. It also used in planning for future expansion of the network. Power flow is basically the computational procedure necessary for calculating the steady state operating characteristic of a proposed network. Basically power flow studies or load flow studies gives steady state operating condition of a proposed network for a given set of bus-bar loads. According to economic dispatching the active powers generations are mentioned. Generation voltage magnitude is kept at a specified voltage level by automatic voltage regulators on the machine excitation side. Loads are basically specified in terms of constant active and reactive power requirements. And it is assumed that the loads are unaffected by little variation of frequency and voltage which is expected during normal steady start operation.

Some prior assumption are made as, power system is a single phase model and it is operating under balanced condition. Those are voltage magnitude " $|V|$ ", phase angle " $\theta$ ", real power " $P$ " and reactive power " $Q$ ".

Since direct analysis of a given network is not possible because the loads are given in terms of complex power instead of impedances and also the generator acts more like power source. The information obtained by power flow/load flow study are:

- voltage magnitude " $|V|$ ", phase angle " $\theta$ " of load buses

- Reactive powers “Q” and voltage phase angles at Generator buses
- Real “P” and reactive “ Q” power flow on transmission link/line
- Finally power “S” at reference bus

The system buses are divided into three categories as follows:

#### 2.4.1 SLACK BUS:

The slack bus or swing bus is basically a bus with a generator where the voltage magnitude and phase angle are known firsthand. The difference between scheduled loads and generated powers is found by this bus which are caused by the power losses in the network.

#### 2.4.2 LOAD BUSES:

For these buses the voltages and phase angles are unknown. Only the active and reactive power is mentioned. These buses are also known as PQ buses.

#### 2.4.3 P-V BUSES:

The P-V buses are known as voltage controlled buses or the generator buses. The voltage magnitudes and real powers are mentioned here. So the phase angle and reactive power has to be determined.

Power flow or the load flow problem results into nonlinear algebraic equations in mathematical formulation which can only be solved by iterative method.

There are various iterative techniques.

- Gauss Siedel power flow solution:
- Fast decoupled power flow solution:
- Newton Raphson load flow solution:

## 2.5 Fast Decoupled Power Flow Solution:

An important and useful property of power system is that the change in real power is primarily governed by the changes in the voltage angles, but not in voltage magnitudes. On the other hand, the changes in the reactive power are primarily influenced by the changes in voltage magnitudes, but not in the voltage angles. To see this, let us note the following facts:

- a. Under normal steady state operation, the voltage magnitudes are all nearly equal to 1.0.
- b. As the transmission lines are mostly reactive, the conductances are quite small as compared to the susceptances ( $G_{ij} \ll B_{ij}$ ).
- c. Under normal steady state operation the angular differences among the bus voltages are quite small ( $\theta_i - \theta_j \approx 0$ ) (within  $5^\circ - 10^\circ$ ).
- d. The injected reactive power at any bus is always much less than the reactive power consumed by the elements connected to this bus when these elements are shorted to the ground ( $Q_i \ll B_{ii}V_i^2$ ).

We have two equations [9]: one is to solve for change in bus angle and one is to solve for the bus voltage which are solved alternatively and always updating with most recent values obtained from these two equations.

$$[B'][\Delta\theta] = \left[ \frac{\Delta P}{V} \right] \quad (2.1)$$

$$[B''][\Delta V] = \left[ \frac{\Delta Q}{V} \right] \quad (2.2)$$

Where

$[B']$  has elements  $-B_{ik}$  ( $i=2,3,\dots,NB$  and  $k=2,3,\dots,NB$ ) of  $Y_{BUS}$  matrix.

$[B'']$  has elements  $-B_{ik}$  ( $i=Nv+1, Nv+2,\dots,NB$  and  $k=Nv+1, Nv+2,\dots,NB$ ) of  $Y_{BUS}$  matrix.

Further simplification of this method can be achieved by:

- a. Omitting that elements of  $[B']$  that mainly affect reactive power flow, i.e. shunt reactances and transformer off-nominal in-phase taps.
- b. Omitting from  $[B']$  the angle shifting effect of the phase shifter that mainly affects reactive power flows.
- c. Also omitting the series resistance in calculating the elements of  $[B']$ , which then will become the dc approximation of the power flow matrix.

### 2.5.1 Fast Decoupled Load Flow Algorithm [4]

- I. Read data  
 NB (total number of buses); NV (total number of PV buses).  
 $V_1, \delta_1$  for slack bus,  $P_i^S (i = 2, 3, \dots, NB)$  for PQ and PV buses.  
 $Q_i^S (i = NV + 1, NV + 2, \dots, NB)$  for PQ buses,  $V_i^S (i = 2, 3, \dots, NV \text{ for PV buses})$ .  
 $V_i^{min}, V_i^{max} (i = NV + 1, NV + 2, \dots, NB)$  for PQ buses.  
 $Q_i^{min}, Q_i^{max} (i=2,3,\dots,NV)$  for PV buses, R (the maximum number of iterations),  $\epsilon$  (tolerance of convergence)
- II. Form  $Y_{BUS}$  as explained in and form  $[B']$  and  $[B'']$  matrices.
- III. Assume initially, voltage magnitudes and voltage angles  
 $|V_i| (i = NV + 1, NV + 2, \dots, NB)$  and  $\theta_i (i = 2, 3, \dots, NB)$
- IV. Set the iteration count r to 0 or r=0.
- V. Compute the active and change in active power ( $P_i$  &  $\Delta P_i$ ) of buses except for the slack or swing bus

$$P_i = \sum_{k=1}^{NB} V_i V_k \left[ G_{ik} \cos(\theta_i - \theta_k) + B_{ik} \sin(\theta_i - \theta_k) \right] \quad (i = 2, 3 \dots NB) \quad (2.3)$$

$$\Delta P_i = P_i^S - P_i \quad (i=2, 3 \dots NB)$$

VI. Compute  $\Delta P^{\max} = \text{maximum} \{ |\Delta P_i| \text{ (} i = 2, 3, \dots, \text{NB)} \}$ .

If  $\Delta P^{\max} \leq \varepsilon_p$  then go to step 9.

VII. Compute  $\Delta \theta_i$  (  $i=2,3,\dots,\text{NB}$  ) using the equation

$$[B'][\Delta \theta] = \left[ \frac{\Delta P}{V} \right]$$

VIII. Modified  $\theta_i$  is calculated as

$$\theta_i = \theta_i + \Delta \theta_i \quad (i=2, 3 \dots \text{NB})$$

IX. Calculate  $Q_i$  and  $\Delta Q_i$  using the formula

$$Q_i = \sum_{k=1}^{\text{NB}} V_i V_k \left[ G_{ik} \sin(\theta_i - \theta_k) - B_{ik} \cos(\theta_i - \theta_k) \right] \quad (i = \text{NV}+1, \text{NV}+2 \dots \text{NB}) \quad (2.4)$$

$$\Delta Q_i = Q_i^s - Q_i \quad (i = \text{NV}+1, \text{NV}+2 \dots \text{NB})$$

X. Compute  $\Delta Q^{\max}$  -maximum  $\{ |\Delta Q_i| \text{ (} i = \text{NV}+1, \text{NV}+2 \dots \text{NB)} \}$ .

If  $(\Delta Q^{\max} \leq \varepsilon_q \text{ and } \Delta P^{\max} \leq \varepsilon_p)$  then go to step 14.

XI. Calculate  $\Delta V_i$  (  $i \text{ NV}+1, \text{NV}+2 \dots \text{NB}$  ) using the equation

$$[B''][\Delta V] = \left[ \frac{\Delta Q}{V} \right]$$

XII. Modify  $|V_i|$  as

$$V_i = V_i + \Delta V_i \quad (i = \text{NV}+1, \text{NV}+2 \dots \text{NB})$$

XIII. Advance the count  $r = r + 1$ .

XIV. Compute slack bus active and reactive power from the following equations

$$P_1 = \sum_{k=1}^{NB} V_1 V_k [G_{1k} \cos(\theta_1 - \theta_k) + B_{1k} \sin(\theta_1 - \theta_k)] \quad (2.5)$$

$$Q_1 = \sum_{k=1}^{NB} V_1 V_k [G_{1k} \sin(\theta_1 - \theta_k) - B_{1k} \cos(\theta_1 - \theta_k)] \quad (2.6)$$

XV. Calculate line flows from the following data

$$S_{ik} = V_i^c [\{(V_i^c)^* - (V_k^c)^*\} y_{ik}^* + (V_i^c)^* y_{ik0}^*] \quad (2.7)$$

$$S_{ki} = V_k^c [\{(V_k^c)^* - (V_i^c)^*\} y_{ki}^* + (V_k^c)^* y_{ki0}^*] \quad (2.8)$$

$$\text{Where } V_i^c = V_i (\cos \theta_i + j \sin \theta_i) \quad (2.9)$$

XVI. Stop.

## 2.6 AC power flow method of contingency analysis

Simplest contingency analysis using AC power flow method consist of running a full AC power flow analysis for every possible contingency be it is generator, transmission line, and transformer outage. This procedure can determine the line overloads and voltage limit violation accurately. But it suffers from a major drawback as full AC power flow requires a long time to execute and also takes a huge amount of computer memory. Thus we require certain index

to rank the contingencies based on their severity and use full AC power flow for some severe cases only. Because most of the power flow results do not show any violation [2].

## 2.7 Performance index

To know how much a particular outage might affect the power system Performance Index or PI is useful. Overload PI can be defined as follows:

$$PI = \sum_{all\ branches} \left( \frac{P_{flowl}}{P_l^{max}} \right)^{2n} \quad (2.10)$$

Where

$P_{flowl}$  is the MW flowing on the line “l”

$P_l^{max}$  is the MW limit of the line “l”

n=1 for exact calculation

Calculation can be made if n=1 and then making a table of all PI values, one for each line in the network. Then the selection can be done by ordering the PI table from largest to least value.

The PI uses DC load flow model for ranking the different cases using the real power flow on line. After the table is made the security analysis starts by executing full power flows for the case at the top of the list and then solve the case which is second and so on until a threshold is reached or when the cases do not give problems.



# **Chapter 3 A NEW METHOD FOR LINE CONINGENCY RANKING**

## **3.1 Introduction**

In PI procedure one need to take each line out or model a line outage for each line. This also need the active power flows or MW (megawatt) flows of all the lines after a particular outage except for the, obviously, opened line. In this paper we have proposed a new method that uses MW flows on the line before it is cut from the network and sensitivity factors called as the “Line outage distribution factor”, which values are constant for a particular transmission network.

## **3.2 Line outage distribution factor**

Line outage distribution factors are applied for overload testing when transmission line or circuit are lost. From the basic definition of line outage distribution factor is:

$$d_{l,k} = \frac{\Delta f_l}{f_k^0} \quad (3.1)$$

Where,

$d_{l,k}$  = line outage distribution factor while monitoring line l when there is an outage on line “k”

$\Delta f_l$  = change in the MW flow on line “l”

$f_k^0$  = MW flow on line “k” before it was outaged

The flow on line “l” when line “k” is out can be determined if power on line “l” and “k” is known by using the “d” factors as follows

$$\hat{f}_l = f_l^0 + d_{l,k} f_k^0 \quad (3.2)$$

Where,

$f_k^0$  and  $f_l^0$  is the preoutage flows on line k and l, respectively

$\hat{f}_l$  is the flow on line l when line k is out

### 3.2.1 Calculation of line outage distribution factor

In a network a line outage can be modeled by means of adding two power injections at both ends or buses without actually the line be cut from the system. If line “k” which is between bus “n” and “m” is to be opened by circuit breaker, no current will flow on the line. This is modeled as two injections while the circuit breaker is still closed as shown in fig 3.2 while

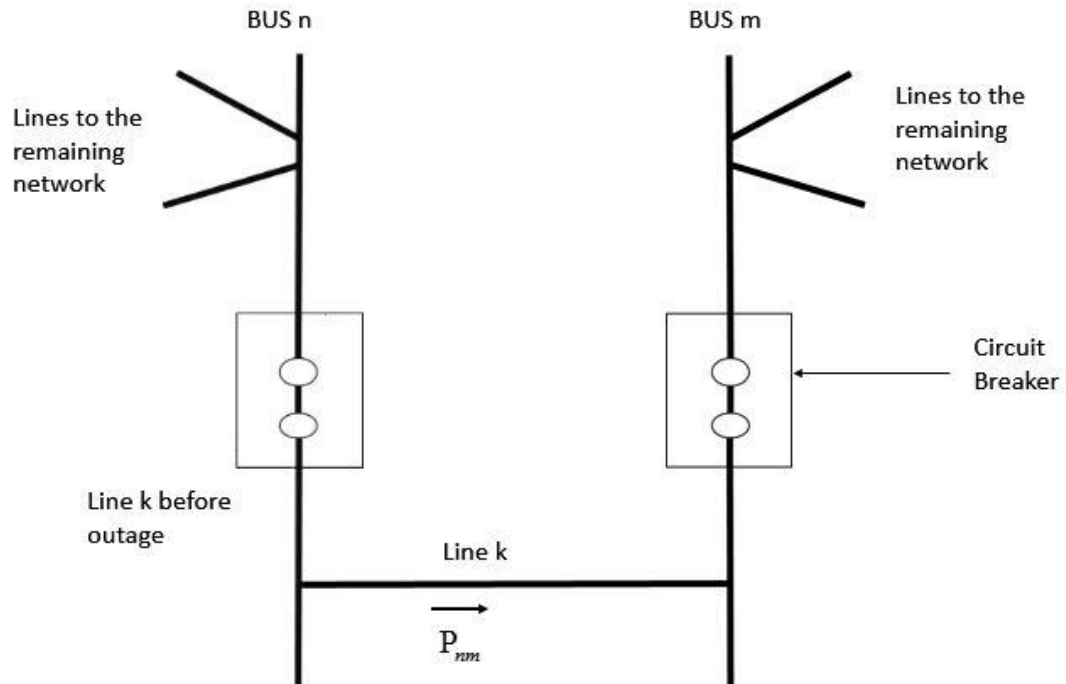

**FIG 3.1 in normal condition**

fig 3.1 shows normal condition. In fig 3.2 we can see that two injections  $\Delta P_n = P'_{nm}$

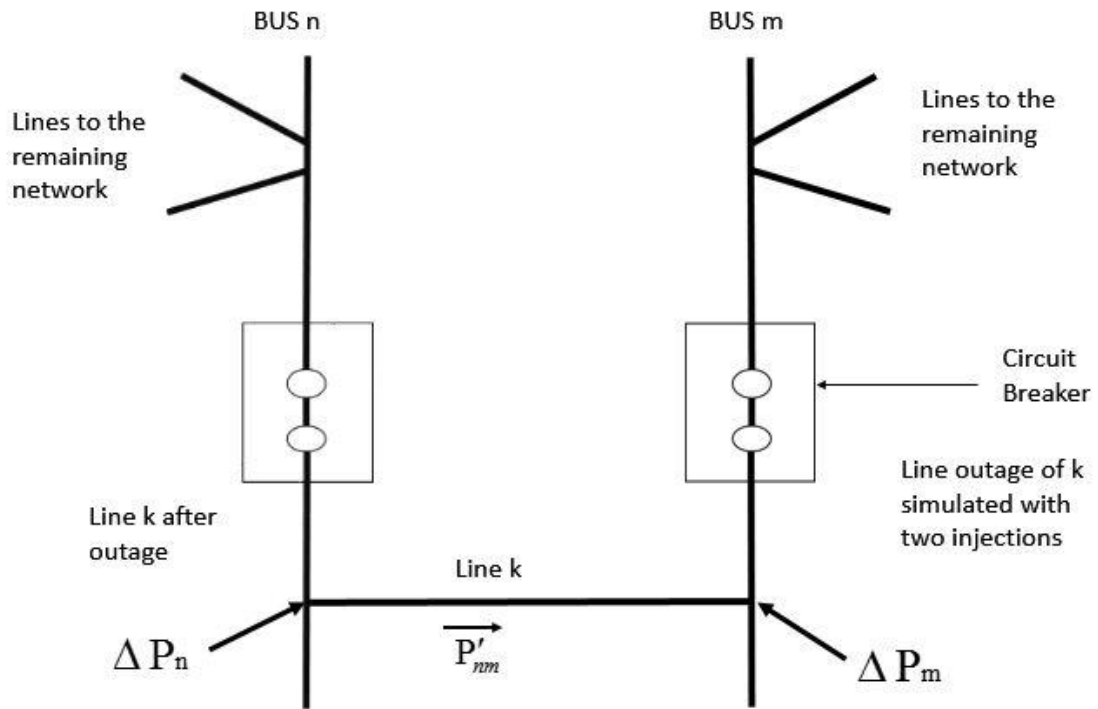

**FIG 3.2 Modelling of line outage of k line**

$\Delta P_m = -P'_{nm}$  at bus n and m respectively.  $P'_{nm}$  is flow on line when line k is out.

Standard matrix calculation for DC power flow is given as:

$$\Delta\theta = [X]\Delta P \quad (3.3)$$

Where  $\Delta\theta$  is the change in bus phase angle,  $[X]$  is inverse of the matrix  $[B]$  and  $\Delta P$  is change in bus injection.

Now,

$$\Delta P = \begin{bmatrix} \cdot \\ \cdot \\ \Delta P_n \\ \cdot \\ \cdot \\ \Delta P_m \end{bmatrix}$$

Then we get

$$\Delta \theta_n = X_{nn} \Delta P_n + X_{nm} \Delta P_m \quad (3.4)$$

$$\Delta \theta_m = X_{mn} \Delta P_n + X_{mm} \Delta P_m \quad (3.5)$$

We previously know that for the outage modeling  $\Delta P_n$  and  $\Delta P_m$  equal the power flowing on the line k after it is out i.e.

$$P'_{nm} = \Delta P_n = -\Delta P_m \quad (3.6)$$

where

$$P'_{nm} = \frac{1}{x_k} (\theta_n' - \theta_m') \quad (3.7)$$

and

$$\begin{aligned} \Delta \theta_n &= (X_{nn} - X_{nm}) \Delta P_n \\ \Delta \theta_m &= (X_{mm} - X_{mn}) \Delta P_n \end{aligned} \quad (3.8)$$

and

$$\begin{aligned} \theta_n' &= \theta_n + \Delta \theta_n \\ \theta_m' &= \theta_m + \Delta \theta_m \end{aligned} \quad (3.9)$$

Now from 3.7 we have

$$P'_{nm} = P_{nm} + \frac{1}{x_k} (X_{nn} + X_{mm} - 2X_{nm}) \Delta P_n \quad (3.10)$$

or

$$\Delta P_n = \left[ \frac{1}{1 - \frac{1}{x_k} (X_{nn} + X_{mm} - 2X_{nm})} \right] P_{nm} \quad (3.11)$$

Now a sensitivity factor  $\delta$  can be defined as the ratio between phase angle change “ $\Delta\theta_i$ ” at any bus “i” to the original real power flow  $P_{nm}$  on line “k” before the outage:

$$\delta_{i,nm} = \frac{\Delta\theta_i}{P_{nm}} \quad (3.12)$$

When neither of “n” or “m” is the reference two bus injections are made as shown in fig. 3.2. Thus change in phase angle at bus “i” is given by

$$\Delta\theta_i = X_{in} \Delta P_n + X_{im} \Delta P_m \quad (3.13)$$

Then using the relationship between  $\Delta P_n$  and  $\Delta P_m$ , we have

$$\delta_{i,nm} = \frac{(X_{in} - X_{im}) x_k}{x_k - (X_{nn} + X_{mm} - 2X_{nm})} \quad (3.14)$$

In case of “n” or “m” being the system reference bus, only one injection be made because phase angle of reference bus does not change.

$$\begin{aligned}\delta_{i,nm} &= \frac{X_{in}X_k}{X_k - X_{nm}} && \text{if "m" is the reference bus} \\ &= \frac{-X_{im}X_k}{X_k - X_{nm}} && \text{if "n" is the reference bus}\end{aligned}\quad (3.15)$$

In case of bus "i" being the reference bus, then  $\delta_{i,nm}$  will be zero since reference bus angle is constant.

Now the line outage distribution factor while monitoring line "l" (between bus "i" and "j") after line "k" (between bus "n" and "m") can be written as

$$\begin{aligned}d_{l,k} &= \frac{\Delta f_l}{f_k^0} = \frac{1}{X_l} \frac{(\Delta \theta_i - \Delta \theta_j)}{f_k^0} \\ &= \frac{1}{X_l} (\delta_{i,nm} - \delta_{j,nm})\end{aligned}\quad (3.16)$$

If neither of bus I or j is a reference bus then

$$d_{l,k} = \frac{1}{X_l} \frac{(X_{in} - X_{jn} - X_{im} + X_{jm})}{X_k - (X_{nn} + X_{mm} - 2X_{nm})}\quad (3.17)$$

For the calculation of line distribution factors the transmission network structure has to be known previously. The lodf (line outage distribution factor) is stored for a given known transmission network.

### 3.3 New method for line contingency selection

The lodf table can be used to derive a new system parameter, which works similar to the PI contingency selection method. It needs only one DC analysis while the system is at normal or steady state condition as compared to "n" analysis in the PI contingency selection method, where

n is number of total line. In PI contingency selection method one DC analysis is required for each modeled line outage.

From Eq. 3.2 we have

$$f_l^\Delta = f_l^0 + d_{l,k} f_k^0$$

then we can write

$$f_l^\Delta - f_l^0 = d_{l,k} f_k^0$$

If we take rms of  $\frac{d_{l,k} f_k^0}{P_l^{\max}}$  ( $P_l^{\max}$  is the max MW limit on line l) for all line “l” when there is an outage on line “k”, we would have a new system parameter. Let’s name it as “effective change in MW flow on all the lines taken together when line “k” is out” or  $P_{eff,k}$ , which is given as:

$$P_{eff,k} = \sqrt{\frac{1}{n} \sum_{\substack{l=1 \\ l \neq k}}^{n=no\ of\ lines} \left( \frac{d_{l,k} f_k^0}{P_l^{\max}} \right)^2} \quad (3.18)$$

$P_{eff,k}$  like PI does not necessarily indicate which bus voltage or line flow violation is happening in the system. What it does is rather compare between other contingencies on the basis of severity. The lines at the top of the  $P_{eff,k}$  list are the candidate for the short list.

If a contingency does happen the operation personnel will have a choice to run a full AC load flow for the case if the case is placed in the short list.

### 3.4 Using $P_{eff,k}$ in contingency selection/screening:

The  $P_{eff,k}$  method can comprises of two stages for selection of line contingency. Firstly, sorting the list according to the  $P_{eff,k}$  values of particular line outages. Secondly, further shortlisting on

the basis of the threshold set by the operator. Let the threshold value be some  $p\%$  of the top member in the  $P_{eff,k}$  table. Then on completion of the two stages in the end full AC load flow will be run for the shortlisted members only and if any line violation is seen, the personnel will be alarmed. Setting of particular threshold values is totally depends on the personnel. A more conservative approach will be the setting of threshold to lower value in case the personnel does not want to miss out on any possible violations.



## **Chapter 4 RESULTS AND DISCUSSION**

### **4.1 Introduction**

For the validation of the method proposed in this thesis  $P_{eff,k}$  is compared to the already pervasive in the field of CA, PI for two systems viz. IEEE 9 bus system and a 6 bus system (Appendix).

### **4.2 IEEE 9 bus system**



IEEE 9 bus system is taken for the study of comparison between PI and  $P_{eff,k}$ .

Table 4.1: Pre contingency MW line flows of IEEE 9 bus system

Serial number	Line between buses	MW Line flow (in p.u.)	% of capacity of line MW
1	6-4	0.303281	30.437
2	7-5	-0.863178	87.277
3	9-6	-0.60478	60.708
4	7-8	-0.753267	75.975
5	5-4	0.426727	48.517
6	8-9	0.229736	27.096

Table 4.1 shows the actual line flows on the lines prior to any contingency and also depicts % loading of lines. Normally a line has capacity to withstand 150% of its MVA limit. Fast Decoupled power flow method has been implied to get the line flow on all the lines.

Table 4.2: LODF of 9 bus system

lines  	k=1(6-4)	k=2(7-5)	k=3(9-6)	k=4(7-8)	k=5(5-4)	k=6(8-9)
l=1 (6-4)		0.999994	-1	-1	0.99998	-0.99999
l=2 (7-5)	1		0.999995	0.999986	-0.999985	1
l=3 (9-6)	- 1.00001	0.999993		-0.999999	0.999979	-0.99999
l=4 (7-8)	- 1.00001	0.999986	-1		0.99972	-1.00001
l=5 (5-4)	1	-0.999998	0.999993	0.999984		1
l=6 (8-9)	-1	0.999998	-0.999994	-1	0.999984	

Where line l=1 and k=1 is between bus 6 and 4.

Using table 4.2 the calculation of  $P_{eff,k}$  table is done and compared with PI in table 4.3.

Table 4.3: Comparison between PI and  $P_{eff,k}$  for IEEE 9 bus system

Line outage ordered by PI (use of six load flow analysis for sorting the index)				Line outage ordered by $P_{eff,k}$ (use of one dc analysis for sorting the index)			
Performance index	Ordered Lines	Overloaded lines	% of capacity of line MW	$P_{eff,k} = \sqrt{\frac{1}{n} \sum_{\substack{l=1 \\ l \neq k}}^{n=no. of lines} \left( \frac{d_{l,k} J_k^0}{P_l^{max}} \right)^2}$	Ordered Lines	Overloaded lines	% of capacity of line MW
7.08181	7-5	9-6 7-8 5-4	147.49 2 157.63 4 133.06 2	0.787965	7-5	9-6 7-8 5-4	147.49 2 157.63 4 133.06 2
4.29623	7-8	7-5	155.64 5	0.687632	7-8	7-5	155.64 5
3.74672	9-6	7-5	149.34 9	0.552084	9-6	7-5	149.34 9
3.28952	5-4	7-5	148.13 5	0.389539	5-4	7-5	148.13 5
2.85392	6-4	7-8	106.29 3	0.276857	6-4	7-8	106.29 3
2.52984	8-9	7-8	100.44 1	0.20972	8-9	7-8	100.44 1

Both PI and  $P_{eff,k}$  are calculated for each contingency and ranked. And then Fast decoupled power flow method has been implied to see the line flow for each contingency.

### 4.3 6 bus system

6 bus system is taken for study of comparison between PI and  $P_{eff,k}$ .

Table 4.4: Pre contingency MW line flows of 6 bus system

Serial number	Line between bus	MW Line flow (MW in p.u.)	% of capacity of line MW
1	1-2	0.268694	89.564
2	1-4	0.437055	87.411
3	1-5	0.357339	89.334
4	2-3	0.0207664	10.383
5	2-4	0.361676	90.418
6	2-5	0.167112	83.556
7	2-6	0.269556	89.852
8	3-5	0.210448	105.224
9	3-6	0.478777	79.796
10	4-5	0.0403673	20.183
11	5-6	0.00921748	4.608

Table 4.4 shows the actual line flows on the lines prior to any contingency and also depicts % loading of lines of 6 bus system. Similar to the 9 bus system.

Table 4.5: LODF for 6 bus system

line 	k=1 (1-2)	k=2 (1-4)	k=3 (1-5)	k=4 (2-3)	k=5 (2-4)	k=6 (2-5)	k=7 (2-6)	k=8 (3-5)	k=9 (3-6)	k=10 (4-5)	k=11 (5-6)
l=1 (1-2)		0.63	0.54	-0.11	-0.50	-0.21	-0.12	-0.13	0.01	0.009	0.13
l=2 (1-4)	0.59		0.45	-0.03	0.61	-0.06	-0.03	-0.04	0.003	-0.32	0.03
l=3 (1-5)	0.40	0.36		0.14	-0.10	0.27	0.15	0.17	-0.01	0.31	-0.17
l=4 (2-3)	-0.10	-0.03	0.17		0.12	0.22	0.46	-0.39	-0.52	0.17	0.13
l=5 (2-4)	-0.58	0.76	-0.17	0.15		0.29	0.17	0.19	-0.019	-0.67	-0.18
l=6 (2-5)	-0.18	-0.05	0.32	0.22	0.22		0.23	0.26	-0.026	0.31	-0.25
l=7 (2-6)	-0.12	-0.03	0.21	0.50	0.14	0.26		-0.19	0.58	0.20	0.44
l=8 (3-5)	-0.11	-0.03	0.20	-0.3	0.14	0.25	-0.17		0.47	0.19	-0.42
l=9 (3-6)	0.014	0.004	-0.02	-0.62	-0.01	-0.032	0.63	0.60		-0.024	0.55
l=10 (4-5)	0.006	-0.23	0.28	0.12	-0.38	0.23	0.13	0.15	-0.01		-0.14

l=11 (5-6)	0.10	0.03	-0.18	0.11	-0.12	-0.23	0.36	-0.40	0.41	-0.17	
------------	------	------	-------	------	-------	-------	------	-------	------	-------	--

Where line l=1 and k=1 is between bus 1 and 2.

Using table 4.5 the calculation of  $P_{eff,k}$  table is done and compared with PI in table 4.6.

Table 4.6: Comparison between PI and  $P_{eff,k}$  for 6 bus system

Line outage ordered by PI (use of 11 load flow analysis for sorting the index)				Line outage ordered by $P_{eff,k}$ (use of 1 load flow analysis for sorting the index)			
Performance index	Ordered Lines	Overload lines	% of capacity of line MW	$P_{eff,k} = \sqrt{\frac{1}{n} \sum_{\substack{l=1 \\ l \neq k}}^{n=no\ of\ lines} \left( \frac{d_{l,k} f_k^0}{P_l^{max}} \right)^2}$	Ordered Lines	Overload lines	% of capacity of line MW
14.9823	3-6	2-6	209.694	0.656401	3-6	2-6	209.694
		3-5	198.713			3-5	198.713
		5-6	113.434			5-6	113.434
		2-3	101.993			2-3	101.993
		1-2	100.199			1-2	100.199
12.2679	1-4	2-4	194.308	0.427948	1-4	2-4	194.308
		1-5	135.321			1-5	135.321
		3-5	105.456			3-5	105.456

12.2099	1-5	3-5	158.764	0.375744	1-5	3-5	158.764
		2-5	150.283			2-5	150.283
		1-4	123.652			1-4	123.652
		2-6	118.015			2-6	118.015
8.26889	2-4	1-4	137.389	0.361161	2-4	1-4	137.389
		3-5	132.471			3-5	132.471
		2-5	123.458			2-5	123.458
		2-6	106.471			2-6	106.471
7.73214	2-6	3-6	114.331	0.292895	2-6	3-6	114.331
		2-5	113.666			2-5	113.666
		1-5	100.2			1-5	100.2
7.23619	2-5	3-5	132.739	0.2242256	3-5	2-5	114.125
		2-6	104.82			2-4	100.417
		1-5	101.235				
		2-4	101.096				
6.81605	1-2	3-5	115.088	0.207225	1-2	3-5	115.088
		1-5	100.579			1-5	100.579
6.65373	3-5	2-5	114.125	0.142659	2-5	3-5	132.739
		2-4	100.417			2-6	104.82
						1-5	101.235
						2-4	101.096
6.57988	4-5	3-5	109.179	0.0369401	4-5	3-5	109.179
6.48895	2-3	3-5	100.7	0.019	2-3	2-3	100.7

6.45791	5-6	3-5	103.656	0.009	5-6	5-6	103.656
---------	-----	-----	---------	-------	-----	-----	---------

Both PI and  $P_{eff,k}$  are calculated for each contingency and ranked. And then Fast decoupled power flow method has been implied to see the line flow for each contingency.

## 4.4 Discussion

As most of the AC power flow analysis does not indicate any line flow or voltage limit violation. Because the system is designed with such redundancy to withstand most of the contingency. The  $P_{eff,k}$  method of contingency selection is time efficient and required only one DC or AC load flow analysis for ranking the contingency whereas the PI contingency selection method required analysis equal to no of lines. It means that  $P_{eff,k}$  method requires less calculation although the lodfs or line outage distribution factors should be known and stored for a particular transmission network. Any significant change in the network will change the lodfs considerably. The lodf is constant and load invariant so  $P_{eff,k}$  can be calculated much faster than PI.

One way to improve the decision making of an operator whether to run a full AC load flow to a particular contingency can be achieved if a threshold value is set in selecting the cases among the already sorted table in according to  $P_{eff,k}$  values. Suppose the operation personnel wants to get informed out of the sorted table which cases might be the problematic ones (let 150 % of MW be the limit of a line), he can set a threshold so that below that value no case will need a full load flow analysis. If the threshold value be 50 % of the top member in  $P_{eff,k}$  table, then from table 4.2 (9 bus system) and table 4.4(6 bus system) we are getting three and four cases respectively. Then instead of performing analysis for all the lines for a particular system (9 bus or 6 bus) we have only three cases in 9 bus system and four cases in 6 bus system where a full analysis is needed.



## **Chapter 5 CONCLUSION & FUTURE SCOPE**

### **5.1 Conclusion**

In the study, a C++ program has been executed on IEEE 9 bus and the given 6 bus system to compare the overload Performance index (PI) and the new  $P_{eff,k}$  or “effective change in MW flow on all the lines taken together when line “k” is out”. It is seen that  $P_{eff,k}$  requires less calculation than PI for ranking different cases. As  $P_{eff,k}$  requires the values of one DC/AC load flow analysis and line outage distribution factor which is constant for a particular transmission network, it can be employed as an alternative for PI,

### **5.2 Future Scope**

The  $P_{eff,k}$  method can be used on various system at different system conditions to study its effectiveness in ranking the cases. This can be applied as contingency screening and only focusing on the bad cases skipping the non-violation cases. This method can be tested on real power system and comparison with the traditional PI could give a clear picture about its effectiveness and correctness.

## **Bibliography**

- [1] A. H. El-Abiad, G. S. (April 1962). Automatic Evaluation of Power System Performance- Effect of Line and Transformer Outage . *Transactions of the American Institute of Electrical Engineers. Part III: Power Apparatus and Systems (Volume:81 , Issue: 3 )*, 712 - 715.
- [2] Allen J.wood, B. F. (1996). *Power Generation, Operation, and control*. Willey-Interscience Publication.
- [3] B. Stott, O. A. (May 1974). Fast Decoupled Load Flow . *IEEE Transactions on Power Apparatus and Systems (Volume: PAS-93 , Issue: 3 )*, 859 - 869.
- [4] D P Kothari, I. J. (2014). *Modern Power System Analysis*. Mc Graw Hill Education.
- [5] G.C. Ejebe, B. W. (Jan/Feb 1979). AUTOMATIC CONTINGENCY SELECTION. *IEEE Transactions on Power Apparatus and Systems, (Volume: PAS-98 , Issue: 1 )*, 97 - 109.
- [6] K. Bhattacharya, M. B. (2001). *Operation of Restructured Power System*. Kluwar Academic Publisher.
- [7] Lai, L. L. (2002). *Power System Restructuring And Deregulation*. John Wily & Sons.
- [8] V. Brandwajn. (February 1988). Efficient Bounding Method for LinearContingency Analysis. *IEEE Transactions on Power Systems (Volume:3 , Issue: 1 )*, 38 - 43.

# Appendix

## A) IEEE 9 Bus system

### A.1 IEEE 9 Bus system Figure

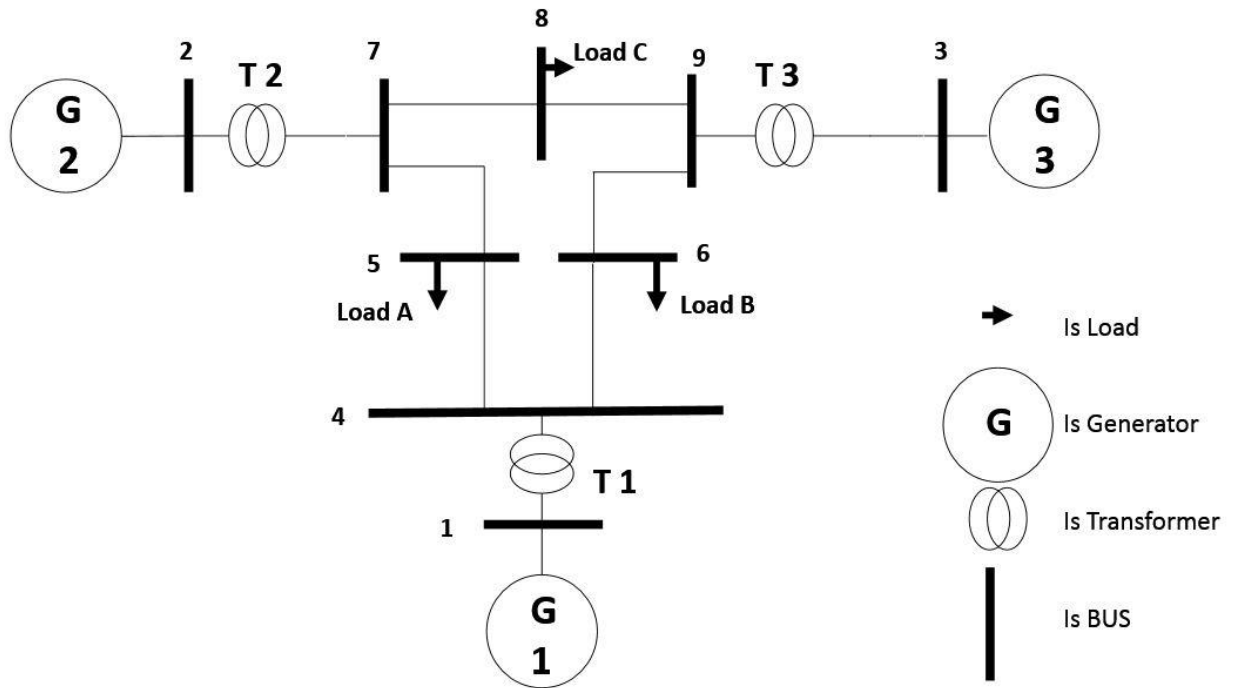

IEEE 9 bus system fig.

## A.2 IEEE 9 bus Data sheet

### Bus Data:-

S.I. number	Bus code	Rated bus voltage (K V)	Active pwr. Gen. (MW)	Reactive pwr. Gen. (MVAR)	Active pwr. Dem.(MW)	Reactive pwr. Dem. (MVAR)	Voltage magnitude(p.u.)	Phase angle	Bus type
1	Bus-1	165.00	74.600	27.000	0.000	0.000	1.0400	0.000	1
2	Bus-2	180.00	163.00	6.7000	0.000	0.000	1.0000	0.000	2
3	Bus-3	138.00	85.000	-10.90	0.000	0.000	1.0000	0.000	2
4	Bus-4	132.00	0.0000	0.0000	0.000	0.000	1.0000	0.000	3
5	Bus-5	132.00	0.0000	0.0000	125.0	50.00	1.0000	0.000	3
6	Bus-6	132.00	0.0000	0.0000	90.00	30.00	1.0000	0.000	3
7	Bus-7	132.00	0.0000	0.0000	0.000	0.000	1.0000	0.000	3
8	Bus-8	132.00	0.0000	0.0000	100.0	35.00	1.0000	0.000	3
9	Bus-9	132.00	0.0000	0.0000	0.000	0.000	1.0000	0.000	3

### Line Data:-

S.I. No	Frm bus	To bus	R in pu	X in pu	Fl line chrgng adm	Capacity MVA	Shunt G	Shunt B
1	6	4	0.01700	0.09200	0.15800	100	0.0000	0.0000
2	7	5	0.03200	0.16300	0.30600	100	0.0000	0.0000
3	9	6	0.03900	0.17000	0.35800	100	0.0000	0.0000
4	7	8	0.00850	0.07200	0.14900	100	0.0000	0.0000
5	5	4	0.01000	0.08500	0.17600	100	0.0000	0.0000
6	8	9	0.01190	0.10080	0.20900	100	0.0000	0.0000

**Transformer Data:-**

S.I. No	Frm bus	To bus	R in p.u.	X in p.u.	Capacity (MVA)	Incre. tap sett.	Min. tap sett.	Max. tap sett.	Current Tap Pos.	Tap ratio
1	2	7	0.0000	0.06250	200	1.25	-8	8	0	1
2	4	1	0.0000	0.05760	100	1.25	-8	8	0	0.98
3	3	9	0.0000	0.05860	100	1.25	-8	8	0	1

**PV Bus data:-**

S.I. No	PV bus no	Min. act. Pwr.(MW)	Max. act. Pwr. (MW)	Min. rect. Pwr. (MVAR)	Max rect. Pwr.(MVAR)	Specfd. Voltage (p.u.)	Min. Voltage (p.u.)	Max. Voltage (p.u.)
1	2	10	200	-20	100	1.025	0.9500	1.0500
2	3	10	200	-20	100	1.025	0.9500	1.0500

**Slack Bus data:-**

S.I. No	Slack bus no	Min. act. Pwr. (MW)	Max. act. Pwr. (MW)	Min. rect. Pwr. (MVAR)	Max. rect. Pwr. (MVAR)	Specified voltage (p.u.)
1	1	10.000	200.000	-10.000	100.000	1.04

# B) 6 Bus System

## B.1 6 Bus system figure

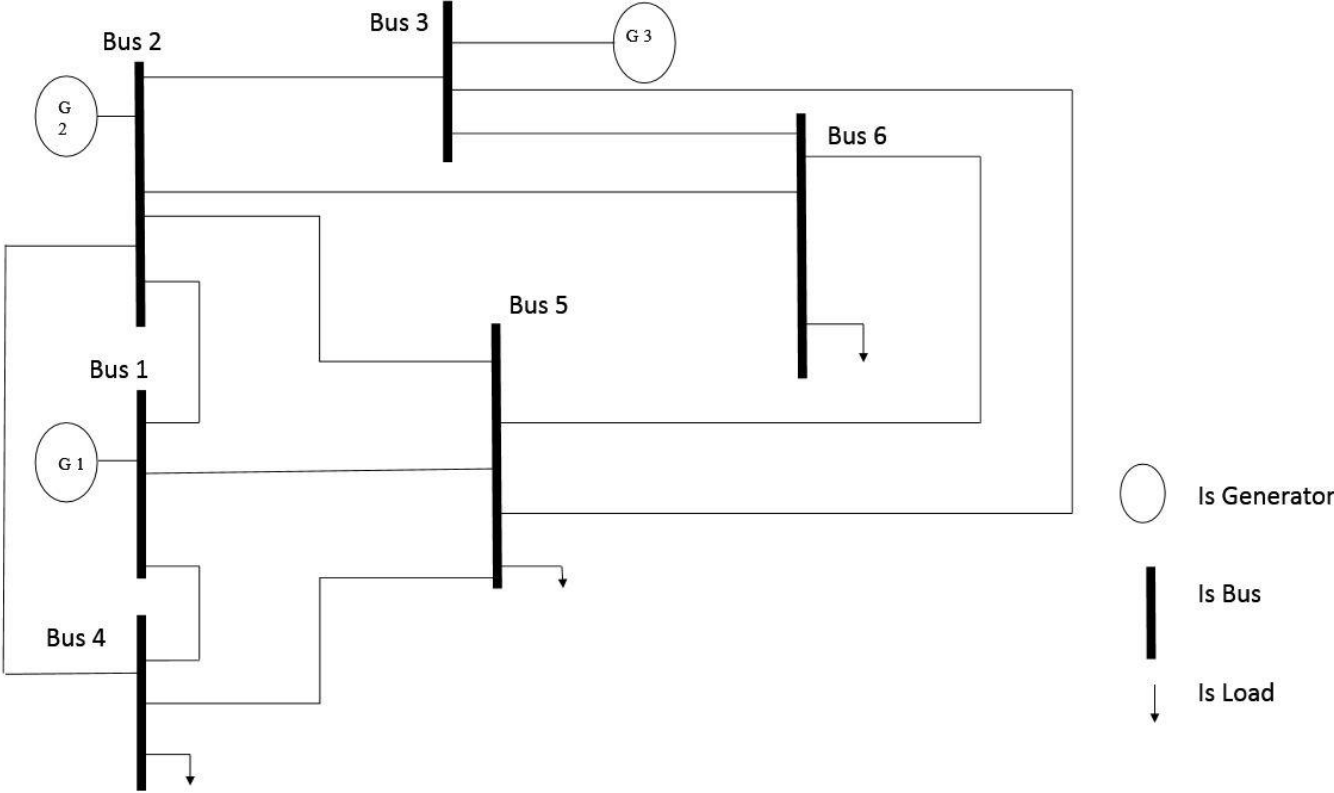

6 bus system fig.

## B.2 Data sheet

Bus data:-

S.I. number	Bus code	Rated bus voltage (p.u.)	Active pwr. Gen. (p.u.)	Reactive pwr. Gen. (p.u.)	Active pwr. Dem.(p.u.)	Reactive pwr. Dem. (p.u.)	Voltage magnitude(p.u.)	Phase angle	Bus type
1	Bus-1	1.05	---	----	---	---	1.05	0.000	1
2	Bus-2	1.05	0.5	0	0.000	0.000	1.05	0.000	2
3	Bus-3	1.07	0.6	0	0.000	0.000	1.07	0.000	2
4	Bus-4	1	0.0000	0.0000	0.7	0.7	1	0.000	3
5	Bus-5	1	0.0000	0.0000	0.7	0.7	1	0.000	3
6	Bus-6	1	0.0000	0.0000	0.7	0.7	1	0.000	3

Line data:-

S.I. No	Frm bus	To bus	R in pu	X in pu	Half total line charging suseptance	Capacity MW (p.u.)	Shunt G	Shunt B
1	1	2	0.10	0.20	0.02	0.30	0	0
2	1	4	0.05	0.20	0.02	0.50	0	0
3	1	5	0.08	0.30	0.03	0.40	0	0
4	2	3	0.05	0.25	0.03	0.20	0	0
5	2	4	0.05	0.10	0.01	0.40	0	0
6	2	5	0.10	0.30	0.02	0.20	0	0
7	2	6	0.07	0.20	0.025	0.30	0	0
8	3	5	0.12	0.26	0.025	0.20	0	0
9	3	6	0.02	0.10	0.01	0.60	0	0
10	4	5	0.20	0.40	0.04	0.20	0	0
11	5	6	0.10	0.30	0.03	0.20	0	0