

Myocardial injury and its prevention in the perioperative setting

M. Zaugg^{1 2*}, M. C. Schaub² and P. Foëx³

¹Institute of Anaesthesiology, University Hospital Zürich, Switzerland. ²Institute of Pharmacology and Toxicology, University of Zürich, Switzerland. ³Nuffield Department of Anaesthetics, The John Radcliffe Hospital, Oxford, UK

*Corresponding author: Institute of Anaesthesiology, University Hospital Zürich, Rämistrasse 100, CH-8091 Zürich, Switzerland. E-mail: michael.zaugg@usz.ch

Br J Anaesth 2004; **93**: 21–33

Keywords: anaesthetic techniques; inhalation; complications; myocardial ischaemia; heart, cardioprotection; hibernation; stunning

In the UK, there are ~20 000 deaths within 30 days of surgery every year, 9000 of which have a cardiac cause.⁹³ The number of major cardiac complications is likely to be in the region of 150 000 per annum. As 60% of patients who die within 30 days of surgery suffer from coronary artery disease⁹⁴ it is reasonable to assume that the majority of cardiac complications of anaesthesia and surgery results from myocardial ischaemia leading to myocardial injury (Fig. 1).

Myocardial responses to ischaemia

Acute myocardial ischaemia

The acute occlusion or progressive constriction of a coronary artery causes reduction or abolition of systolic shortening and thickening of the ischaemic wall.⁸¹ Ischaemic segments also demonstrate paradoxical wall motion (termed post-systolic shortening or post-systolic thickening). These functional changes relate directly to the severity of the reduction in coronary blood flow. As post-systolic shortening and thickening occur after aortic valve closure, they do not contribute to ejection and result in an internal shift of blood in the ventricle, and may impair relaxation. Acute or progressive ischaemia of the left ventricle also cause an increase in chamber stiffness in the ischaemic and in remote non-ischaemic segments.⁸¹ This generalized increase in myocardial chamber stiffness contributes to an elevation of the left ventricular end-diastolic pressure, especially in the presence of volume loading.⁸¹ The increase in end-diastolic pressure contributes to a vicious circle as it further impairs coronary blood flow by increasing diastolic wall tension. The mechanisms of the

increase in ventricular chamber stiffness of remote, well-perfused myocardium have not been elucidated. However, ventricular stiffening does not depend on loading conditions and is likely to result from the release of mediators.

Mechanisms of myocardial ischaemia

The time-course of the effects of ischaemia on cardiac tissue is well known. There is a marked reduction of contractile function resulting from decreased ATP production a few seconds after the onset of ischaemia. Leakage of potassium ions is responsible for the alterations of ST-segments. Within minutes, an intracellular acidosis develops associated with an increase in myoplasmic Ca²⁺ and the beginning of cell swelling. Later, cellular lesions become irreversible. The ultrastructure of the cells becomes altered and macromolecules (CK-MB, troponins) are released. An increased concentration of cytosolic and mitochondrial Ca²⁺ plays a central role in the damage to the cells and their membranes¹⁰⁴ (Fig. 2).

Myocardial ischaemia occurs in the presence of fixed or dynamic coronary artery stenoses and, in the case of the right ventricle, in response to afterload mismatch. The main causes of ischaemia with fixed coronary stenoses include tachycardia, excessive left ventricular filling, and hypoxaemia. Tachycardia, systolic hypertension and β -adrenergic stimulation increase the oxygen requirements and may decrease oxygen delivery. Causes of ischaemia in the presence of dynamic stenoses include those described above and, in addition, activation of sympathetic and parasympathetic systems. Moreover, several endothelium-derived mediators may enhance vasoconstriction.

In the normal heart, the role of the autonomic nervous system is overshadowed by local metabolic coronary vasoregulation. Normally, activation of the sympathetic

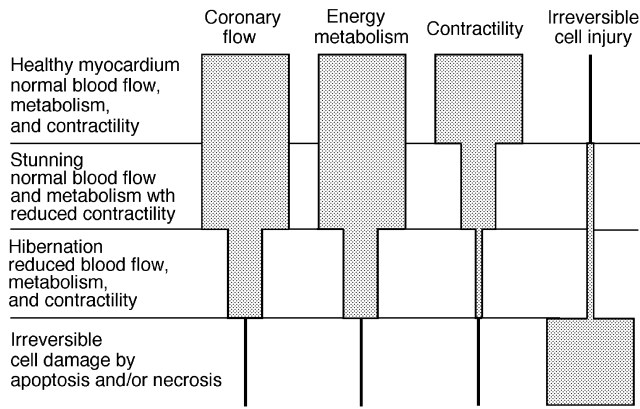

Fig 1 Schematic characterization of cardiac 'stunning' and 'hibernation'. In stunning normal blood flow and energy metabolism are accompanied by reduced contractility, designated as 'flow-contraction mismatch'. The impaired contractile function seems to be caused primarily by increased intracellular Ca^{2+} , activation of Ca^{2+} -dependent non-lysosomal cysteine proteinases (calpains), and degradation of sarcomere-associated proteins including troponin-I. Hibernation is characterized by reduced contractility accompanied by reduced oxygen consumption as a consequence of reduced blood flow. Partially damaged cardiomyocytes can be rescued to full function after stunning as well as after hibernation, provided normal blood flow is restored after the latter within the critical time period before irreversible cell damage has occurred. Despite their distinct definition, stunning and hibernation may merely represent intermediary states in a continuum extending from unimpaired functional myocytes to necrosis.¹⁵⁷

nervous system at the level of α_1 - and β_1 -adrenoceptors increases blood pressure, heart rate, and contractility. As a result, myocardial oxygen consumption increases and local vasoregulation decreases coronary vascular resistance. The direct effect of α_1 -adrenoceptor stimulation, vasoconstriction, is minimal under normal circumstances but may be exaggerated in the presence of coronary artery disease, extreme exercise, or haemorrhagic shock. Activation of the parasympathetic system causes bradycardia and hypotension, thereby reducing myocardial oxygen requirements. Local regulation increases coronary vascular resistance and the direct coronary vasodilatation caused by acetylcholine is masked.

Endothelins act on vascular smooth muscle and are extremely powerful vasoconstrictors. However, they exert complex physiological effects. Through activation of endothelin B (ET_B)-receptors, endothelial nitric oxide synthase is activated and nitric oxide is released causing cGMP-mediated vasodilatation. Activation of ET_B -receptors also increases the activity of cyclo-oxygenase leading to the release of prostaglandin I_2 (PGI_2). The latter causes vasodilatation and minimizes smooth muscle cell proliferation. When the endothelium is normal, there is a delicate balance between vasoconstriction and vasodilatation in response to endothelins. The vasodilatory role of the endothelium becomes more apparent when it is damaged by atheroma, hypercholesterolaemia, hypertensive heart disease, and after reperfusion. An imbalance of mediators

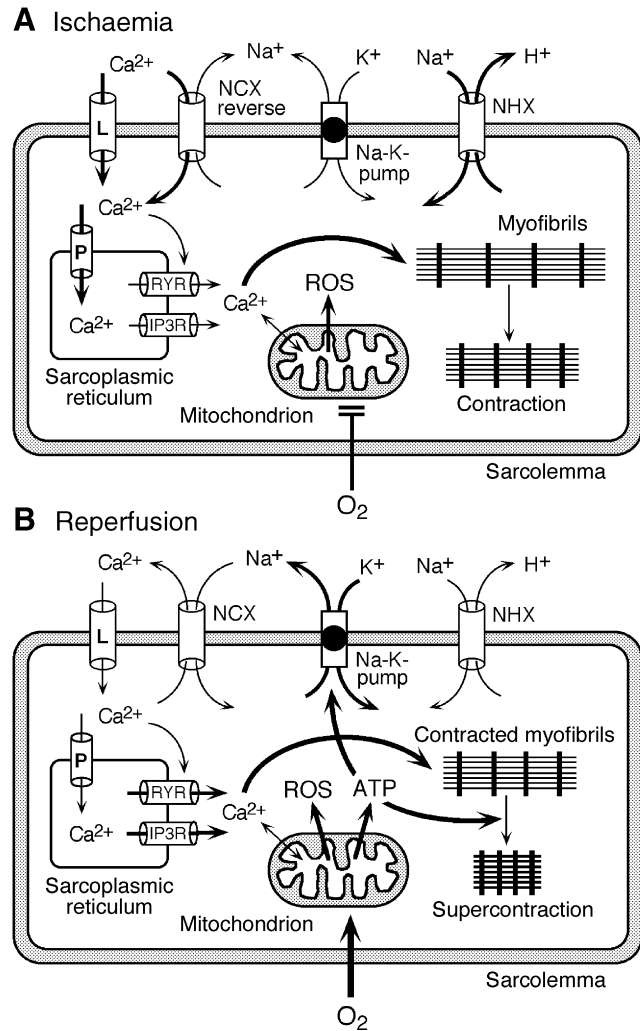

Fig 2 Changes and consequences of cation fluxes during ischaemia-reperfusion. (A) Cessation of oxygen supply in ischaemia leads to a loss of ATP production and an increase of reactive oxygen species (ROS) in the mitochondria. Reduced activity of the ATP consuming Na^+ - K^+ -pump lowers the outside-inside sodium gradient, Na^+ accumulates in the myocyte and the resting membrane potential is lowered. With the development of acidosis, the Na^+ - H^+ -exchanger (NHX) further increases intracellular Na^+ . Under these conditions the Na^+ - Ca^{2+} -exchanger (NCX) operates in the reverse mode, letting Ca^{2+} into the cell. Ca^{2+} also enters through the sarcolemmal L-type voltage-gated Ca^{2+} -channel (L) as the resting membrane potential is low. The increased Ca^{2+} is taken up into the sarcoplasmic reticulum (SR) by the SR Ca^{2+} -pump SERCA2 (P) and released from there via two types of release channels, the ryanodine receptor channel (RYR) and the IP3 receptor channel (IP3R), leading to contraction. (B) Reoxygenation during reperfusion restores ATP production with a further boost of ROS. Reactivation of the Na^+ - K^+ -pump by ATP slowly restores the sodium gradient leading to normal cation fluxes with the NCX eventually extruding the excess of cytosolic Ca^{2+} . During the early reperfusion phase when the intracellular Ca^{2+} level is still high, myocardial contracture (supercontraction of myocytes) may develop. When contracture affects the entire heart as it may occur after global ischaemia, it has been termed the 'stone heart' phenomenon.^{104 157}

can then develop and facilitate vasoconstriction. There are several important mechanisms involved in this vasoconstriction. Norepinephrine causes α_1 -adrenoceptor-mediated

vasoconstriction. When the endothelium is damaged, acetylcholine causes muscarinic receptor mediated vasoconstriction,⁷⁹ instead of endothelium-dependent vasodilatation. Thus, with endothelial damage both sympathetic and parasympathetic stimulation may cause coronary vasoconstriction. As sympathetic overactivity is part of the perioperative stress response, exaggerated vasoconstriction may be expected to contribute to perioperative myocardial ischaemia and cardiac damage. Similarly, the effects of endothelins are altered when the endothelium is damaged and activation of nitric oxide-synthase and cyclo-oxygenase does not occur. Consequently, only effects of endothelins in these circumstances are those on endothelin A (ET_A)- and ET_B-receptors in vascular smooth muscle resulting in vasoconstriction and smooth muscle proliferation.

Myocardial stunning (flow-contraction mismatch)

The term myocardial stunning was coined by Braunwald and Kloner¹⁴ in 1982 to describe a reduction in function after a brief period of ischaemia followed by reperfusion. The impairment of function could last for several hours or days at a time when coronary blood flow was normal and there was no obvious cellular damage. In clinical practice, interventions such as transluminal coronary angioplasty, coronary artery bypass graft surgery, and thrombolysis after myocardial infarction are human models of ischaemia-reperfusion phenomena. During the perioperative period, a high proportion of adult patients suffer from episodes of myocardial ischaemia, most of which are silent but can be prolonged. Importantly, silent myocardial ischaemia is supposed to be a common cause of myocardial stunning and is a predictor of adverse cardiac outcome.

Mechanisms of myocardial stunning

Myocardial ischaemia followed by reperfusion causes reversible or irreversible damage depending on its duration (Figures 1 and 2). In stunning, ischaemic damage is, in principle, reversible.⁶⁷ Three main mechanisms are involved in the establishment of stunned myocardium: formation of free oxygen radicals, accumulation of intracellular Ca²⁺, and degradation of contractile proteins. Many studies have shown that during ischaemia, but more importantly during reperfusion, considerable production of free oxygen radicals occurs.⁹⁹ Free radicals do not have a single target, but adversely affect many components of the cell including sarcolemmal and subcellular membranes of organelles. The role of free radicals in stunning is confirmed by the improved post-ischaemic functional recovery in the presence of superoxide dismutase.¹³⁸ Production of free radicals involves xanthine oxidase, oxidation of catecholamines, uncoupling of mitochondrial respiration, and activation of neutrophils.

During ischaemia and the early phase of reperfusion, there is an increase in the concentration of intracellular

Ca²⁺. Although disappearing in the late phase of reperfusion, Ca²⁺ overload can decrease the sensitivity of contractile proteins to Ca²⁺, thus diminishing the developed force.⁹ Ca²⁺ overload may result from altered characteristics of the Na⁺/Ca²⁺ antiport and from altered Ca²⁺ fluxes at the level of the sarcoplasmic reticulum. Such alterations in Ca²⁺ handling may be attributable to ischaemia-induced intracellular acidosis. During the early phase of reperfusion, the H⁺/Na⁺ antiport is maximally stimulated. While the acidosis is progressively corrected, there is an increase in intracellular Na⁺ leading to a further increase in Ca²⁺.

Furthermore there is some evidence that translocation of heat-shock proteins (Hsp-27, α B-crystalline) with covalent binding to myofibrils, together with degradation of contractile proteins such as troponin I, as evidenced in a transgenic mouse model overexpressing troponin I fragments,⁸⁸ may be, at least in part, involved in the pathogenesis of myocardial stunning. Also, an increase in coronary vascular resistance and a reduction in vasodilator response were previously reported during reperfusion and may represent some sort of vascular counterparts of stunning in endothelial cells ('microvascular stunning').¹⁰ However, not all studies confirm this phenomenon.³²

Myocardial hibernation

The concept of myocardial hibernation was put forward by Rahimtoola in 1985.^{110 111} In the hibernating myocardium, ventricular function is diminished as a consequence of insufficient coronary blood flow (Fig. 1). However, this reduction is not necessarily permanent: an improved balance of supply and demand may augment myocardial function.^{7 78} The issue of myocardial hibernation is clinically important because the risk of adverse cardiac outcome in cardiac and non-cardiac surgery increases with a reduction of the ejection fraction. If coronary revascularization increases the ejection fraction the risk of adverse cardiac outcome is likely to be reduced. The likelihood of improved function after coronary reperfusion can be predicted by the result of a dobutamine stress echocardiogram. If dobutamine worsens ventricular function (reversible ischaemia) coronary revascularization is likely to improve cardiac function.¹

Mechanisms of myocardial hibernation

In hibernating myocardium, cardiac metabolism is down-regulated. It has been proposed that abolition of contractility of hibernating cardiac tissue is attributable to chronic stunning caused by multiple episodes of severe ischaemia followed by repetitive reperfusion. Other experimental models suggest that hibernation occurs as a result of chronic low-flow states. In either case, hibernating myocardium should be salvageable by restitution of an adequate coronary blood flow.

Myocardial preconditioning

In 1986, Reimer and colleagues¹¹² reported that a brief period of ischaemia decreased the rate of ATP depletion during a further period of ischaemia. Murry and colleagues⁸⁹ reported that brief periods of ischaemia made the heart more resistant to infarction during a subsequent acute coronary occlusion, reducing the infarct size by 70–80%. This phenomenon, termed myocardial preconditioning is the most powerful means of achieving cardiac protection. Protection conferred by ischaemic and (most) pharmacological preconditioning protocols exhibits two windows: an acute memory phase that develops within minutes of the ischaemic stimulus and lasts only between 1 and 3 h (classic or early preconditioning), and a longer, more delayed, phase (late preconditioning) starting after 12–24 h and persisting for 2–4 days.¹⁵⁶ Delayed protection by preconditioning is thought to be primarily attributable to alterations in gene expression. Myocardial preconditioning has been documented in all animal species in which it has been studied and in human cardiac tissue. Whether preconditioning facilitates the recovery of function in stunned myocardium is still debated.^{19 101} However, delayed preconditioning, in contrast to early preconditioning, always confers protection against stunning.

Preconditioning can result from successive episodes of angina or silent myocardial ischaemia. Indeed, infarct size is known to be smaller, if it has been preceded by angina.^{69 91 100} Preconditioning also reduces the risk of ischaemia-induced ventricular tachycardia and ventricular fibrillation.¹⁴⁵ In an almost experimental situation, preconditioning can occur during coronary angioplasty where several temporary occlusions are applied and the effects of a longer period of occlusion are minimized. During coronary angioplasty, sequential occlusions cause less angina, smaller ST-segment changes and lesser lactate production than the first 90 second occlusion.²⁸ Also, delayed preconditioning can be observed after prolonged nitroglycerin administration in patients undergoing angioplasty 24 h later. Although ischaemic preconditioning, or agents that mimic preconditioning, elicit cardiac protection in patients undergoing cardiac surgery,⁵¹ the clinical use of preconditioning in cardiac surgery is controversial as some studies show benefits^{48 148} while others do not,^{59 72 102} or even demonstrate deleterious effects.

Mechanisms of myocardial preconditioning

Ischaemic stimuli cause the release of stress mediators such as adenosine, bradykinin, norepinephrine, and opioids. The mechanisms of preconditioning involve several types of triggers and mediators¹⁵⁶ (Fig. 3). Amongst them, adenosine A₁- and A₃-receptors, bradykinin₂-receptors, δ₁-opioid receptors and α₁-adrenoceptors play an important role. Via G-proteins, phospholipase C (PLC) and protein kinase C (PKC), these receptors act on mitochondrial and sarcolemmal K_{ATP} channels and Ca²⁺ channels.^{152 153} As many mediators are involved in preconditioning, and many

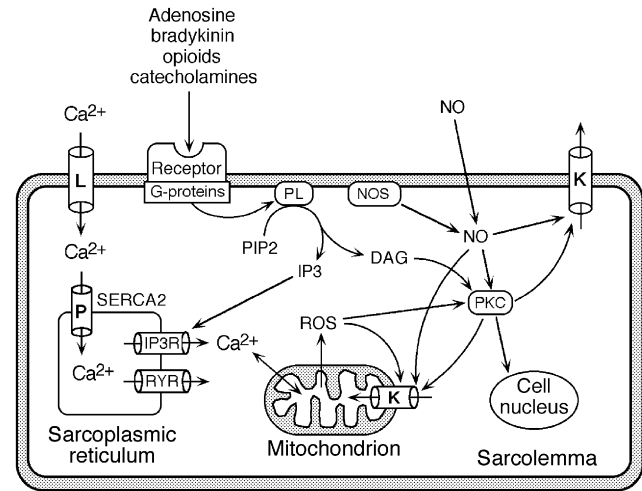

Fig 3 Main signalling pathways in ischaemic preconditioning. Stimulation of G-protein coupled receptors by primary messengers activates phospholipases (PL), which in turn produce two second messengers originating from phosphatidylinositol bisphosphate (PIP₂), namely inositol trisphosphate (IP₃) and diacylglycerol (DAG). The former releases Ca²⁺ from the sarcoplasmic reticulum (SR) via the IP₃ receptor channel (IP₃R), the latter activates different PKC isoforms (PKC). PKC isoforms translocate to their appropriate target sites, activating the sarcolemmal and mitochondrial ATP-dependent potassium channels (K) and initiating distinct gene expression in the cell nucleus. Nitric oxide originating from either the endogenous NO-synthase (NOS) or from extracellular sources may also activate PKC and the potassium channels directly or via its reactive nitrogen oxide products (not shown in this figure). The same mechanism holds true for the reactive oxygen species (ROS) that are produced in the mitochondria under stress and increased Ca²⁺. Ca²⁺ enters the myocyte via the L-type voltage-gated Ca²⁺-channel (L) and is taken up into the SR by the Ca²⁺-pump (SERCA2). Ca²⁺-release from the SR for contraction primarily occurs via the ryanodine receptor channel (RYR).

substances are capable of preventing it, a ‘summation hypothesis’ has been proposed by Downey and colleagues.^{31 36} In order for ischaemic preconditioning or pharmacological preconditioning to occur, it is necessary to reach an activation threshold. This threshold represents the sum of the activity of several mediators. The role of lactate as a triggering mechanism is controversial, even though lactate can open K_{ATP} channels and increase the expression of heat-shock proteins.^{4 65} Ischaemic preconditioning is caused by temporary occlusions, generally lasting 5 min, followed by reperfusion. A comparison of various numbers of cycles of ischaemia-reperfusion shows that protection is best with 1–4 cycles. With six or more cycles protection is reduced and ultimately lost.⁴⁷ While one cycle may be enough to trigger the release of protective substances, many more cycles may be unable to enhance further release of triggers. A high number of short ischaemic periods may start to cause cumulative ischaemic damage, thus decreasing the efficacy of preconditioning.⁴⁷

Preconditioning reduces cardiomyocyte necrosis *in vivo* and *in vitro*. Apoptosis is known to increase with ischaemia.

In ischaemia-reperfusion, both ischaemia and reperfusion contribute equally to apoptosis.⁷⁶ By contrast, necrosis occurs primarily during reoxygenation. Preconditioning effectively reduces necrosis and apoptosis. Opening of K_{ATP} channels together with modulation of Ca^{2+} homeostasis may explain why inhalation anaesthetics inhibit apoptosis in cardiomyocytes.^{3 151}

Role of adenosine

The role of adenosine in preconditioning has been well documented. Adenosine A_1 -receptor activation plays an important role. These receptors are coupled with K_{ATP} channels⁶⁸ via Gi-proteins. Activation of adenosine receptors decreases the production of reactive oxygen species and attenuates myocardial stunning.⁹² The role of adenosine receptors in preconditioning is confirmed by the observation that adenosine A_1 -receptor antagonists can block K_{ATP} channels, thereby preventing ischaemic preconditioning. In addition, preconditioning can be mimicked by adenosine A_1 -receptor agonists.

Role of bradykinin

Bradykinin is an inflammatory stress mediator and a vasodilator. In some experimental models, an infusion of bradykinin has been shown to reduce ischaemic injury,^{15 36} while bradykinin receptor antagonists negated the protection conferred by ischaemic preconditioning.^{15 36}

Role of opioids

Morphine and fentanyl have been shown to precondition the myocardium.^{58 120 152} Conversely, δ -opioids receptor antagonists prevent ischaemic preconditioning.^{84 122 123}

Role of adrenergic receptors

Both α - and β -adrenoceptors are involved in preconditioning. While preconditioning is induced primarily by β_1 -adrenoceptors,³⁴ β_2 -adrenoceptor may play a role via activation of L-type calcium channels. Brief episodes of ischaemia cause the release of norepinephrine in the myocardium, while exogenous α_1 -adrenoceptor agonists may cause pharmacological preconditioning.¹³²

Role of free oxygen radicals and nitric oxide

Free radicals cause myocardial damage during ischaemia-reperfusion. However, treatment with small amounts of free radicals before an ischaemic insult can reduce infarct size *in vitro*,⁶ an effect that is abolished by free radical scavengers. Nitric oxide-cGMP signalling is also important.^{25 33 92 152} Inhalation anaesthetics may modulate the activity of various isoenzymes of nitric oxide synthase (nNOS, eNOS, iNOS) as they are heterogeneously distributed in the myocardium.

Calcium ions

A preischaemic increase in Ca^{2+} represents a second messenger in the development of ischaemic precondition-

ing,⁸⁵ even though Ca^{2+} overload is a major contributor to cell damage. Short-time administration of increased Ca^{2+} concentrations to myocardial tissue is an effective preconditioning stimulus, which can be inhibited by administration of Ca^{2+} channel blockers.¹⁴¹

Protein kinase C (PKC)

PKC transfers γ -phosphoryls from ATP to hydroxyl groups of serine/threonine residues in proteins. This phosphorylation controls the function of many cellular effectors. PKC plays an important role in ischaemic and pharmacological preconditioning.^{50 113 134 139} PKC activators can induce, while PKC inhibitors prevent preconditioning.¹⁵⁰ Inhalation anaesthetics may directly activate PKC. Importantly, preconditioning-associated isoform translocation of PKC to subcellular targets is highly dependent on species, age, and on the type of preconditioning stimulus.

Role of ATP-dependent potassium channels (K_{ATP} channels)

Ultimately, K_{ATP} channels hold the central role in ischaemic and pharmacological preconditioning¹⁵³ (Figures 2 and 3). Sarcolemmal K_{ATP} channels were described by Noma in 1983.⁹⁶ These channels open when ATP levels fall, allowing potassium efflux so causing membrane hyperpolarization and reducing the action potential duration. These changes decrease the open probability of voltage-gated Ca^{2+} channels. The resulting reduction in Ca^{2+} concentration preserves ATP levels and reduces coronary vascular tone.¹¹⁸ The increase in extracellular potassium also facilitates coronary vasodilatation and increases blood flow to the ischaemic region.⁵ K_{ATP} channels mediate the response to hypoxia and the hyperaemic response to brief coronary occlusions. However, reduction of action potential duration does not correlate with the reduction in infarct size. Surface K_{ATP} channels were initially thought to mediate preconditioning. More recent evidence indicates that mitochondrial K_{ATP} channels play a pivotal role in mediating cardiac preconditioning.^{35 153} Opening of mitochondrial K_{ATP} channels may optimize mitochondrial energy production, decrease mitochondrial Ca^{2+} overload, and prevent opening of mitochondrial permeability transition pores (Fig. 4).^{30 43 83 157} Numerous studies have confirmed the important role of these channels. The role of K_{ATP} channels in human preconditioning is evidenced by the observation that ischaemic preconditioning does not occur in patients taking sulfonylureas, as these agents block K_{ATP} channels.^{13 21}

Other beneficial effects associated with cardiac preconditioning

Glycogen depletion and lactate accumulation during ischaemic preconditioning periods play a role in myocardial protection. Indeed, transient exposure to lactate improves contractile recovery in rat heart.²⁹ Entrapment of neutrophils and platelets in the coronary vasculature occurs in ischaemia. The protective effects of preconditioning also

extend to the endothelium of the coronary vasculature and to the adhesion properties of platelets and leucocytes to these vessels. Ischaemic preconditioning reduces ICAM-1 production and thus neutrophil entrapment.¹¹⁶ In turn, reduced neutrophil and platelet entrapment is associated with enhanced post-ischaemic function.^{44 45}

Late preconditioning

Late preconditioning is mediated by inducible nitric oxide synthase^{129 146} and can be elicited by nitric oxide donors.^{46 130} It can also be triggered by heat stress, lipopolysaccharides (LPS), or monophosphoryl lipid A; these are known to trigger delayed endogenous protective mechanisms against myocardial ischaemia-reperfusion injury appearing after 24 h and lasting for several days.¹¹ Alterations of gene expression of protective and anti-protective proteins along with K_{ATP} channel opening have been proposed as the main mechanisms for this delayed protection. The endocannabinoid system is involved in the protection conferred by LPS, in relation with nitric oxide production.⁷⁴ Two endocannabinoids act through interaction with G-protein coupled membrane receptors, namely CB_1 - and CB_2 -receptors, which are present throughout the body.¹⁰³ Endocannabinoids have been implicated in the inflammatory response. In isolated rat hearts, endocannabinoids acting through CB_2 -receptors and nitric oxide, play a role in the protection conferred by heat stress against myocardial ischaemia.⁵² Hemin is an activator of the potent antioxidant enzyme heme oxygenase-1 and may play a role in delayed protection.¹⁴⁹ Enhanced expression of heme oxygenase-1 has been observed during the recovery phase of porcine myocardial stunning.¹²⁵ Indeed, in experimental studies, a significant attenuation of stunning, as evidenced by enhanced recovery of wall thickening was observed in animals pretreated for 1 week with hemin.¹⁴³ Whether inhalation anaesthetics are capable of eliciting late preconditioning is not yet clear.

Remote preconditioning

Ischaemic preconditioning can be generated by short episodes of myocardial, limb, or visceral ischaemia. In the heart itself, preconditioning can develop in areas remote from the preconditioning ischaemic stimulus (for review see¹⁵⁶). This remote preconditioning may involve the release of adenosine, bradykinin, norepinephrine, and activation of K_{ATP} channels. Systemic effects of localized ischaemic preconditioning have been reported. This raises the issue that regional ischaemia of non-vital tissues might protect remote vital organs.³⁷ In volunteers, transient remote ischaemia of one limb induced remote ischaemic preconditioning of the opposite limb as evidenced by preservation of endothelial function (estimated as extent of vasodilator response).⁶⁶ Cytokines and other metabolic mediators are likely to play a role. The autonomic system may also be involved as well as modulation of platelet, endothelium, and leucocyte function.

Protective effects of anaesthetics against ischaemia

Anaesthetics and myocardial stunning

Most inhalation anaesthetics and high dose opioids confer protection, increasing the rate of myocardial recovery after reperfusion.^{58 115} In 1988, Warltier and colleagues¹⁴² demonstrated that administration of halothane and isoflurane before ischaemia improved the speed of recovery of function after a brief (15 min) period of ischaemia. After 5 h, the functional recovery in the presence of inhalation anaesthesia was 100% vs 50% only in the controls.¹⁴² Since then, these observations have been confirmed repeatedly.^{22 134} However, some studies of isolated heart preparations showed no protection by inhalation anaesthetics.^{97 117} More recently, sevoflurane and desflurane were shown to confer cardiac protection.^{108 109 119 133 135} It is likely that protection by inhalation anaesthetics is attributable to pharmacological preconditioning of the heart, as in many studies the inhalational anaesthetic was given before ischaemia and reperfusion. Indeed, in some studies the administration of the inhalation anaesthetic was discontinued before ischaemia-reperfusion and resulted in reduced infarct size.^{18 24} Nonetheless, protective effects of inhalation anaesthetics were also reported if inhalation anaesthetics were administered exclusively during the reperfusion phase.

Intravenous anaesthetics appear to confer less protection.^{23 27 144} Fentanyl and propofol appear to be equivalent.¹¹⁴ In the isolated heart, as opposed to the intact instrumented heart, propofol has been shown to reduce infarct size and cellular damage.^{70 71 82} Propofol-induced protection was not abolished by block of K_{ATP} channels. While the effects of opioids on infarct size have been well demonstrated, there are only a few studies of their effects on myocardial stunning.^{114 144} In the isolated heart, high concentrations of fentanyl have been shown to offer significant protection.⁵⁸ Protection was mediated by δ -opioid receptors, adenosine A_1 -receptors, PKC, and K_{ATP} channels.^{56 57} The role of δ -opioid receptors is supported by the abolition of their protective effect by naloxone.^{20 122 131} As wash-out of opioids does not prevent their effect, they must act as preconditioning agents.^{2 75} It is further possible that opioids act beneficially via a reduction in adhesion and migration of neutrophils.^{128 140}

Anaesthetics and cardiac preconditioning

Many anaesthetic agents have been shown to reduce infarct size in experimental models. Not all anaesthetics have the same efficacy. There is greater reduction of infarct size by halothane, enflurane, and isoflurane in comparison with pentobarbital, ketamine-xylazine, or propofol anaesthesia in rabbits. Dogs anaesthetized with barbiturates exhibit larger infarcts than their conscious counterparts.⁵³ This may be

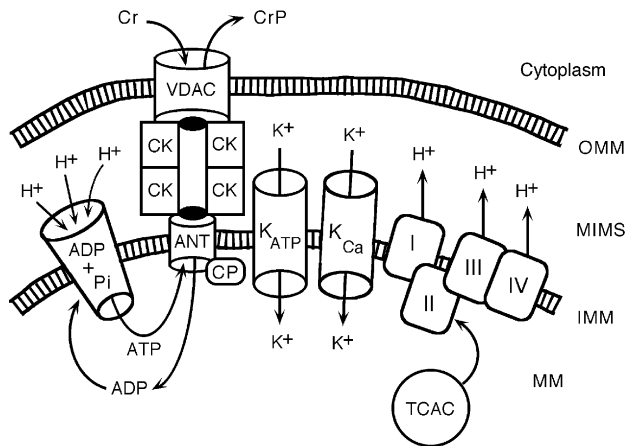

Fig 4 Functional connections between the mitochondrial permeability transition pore (mPTP) and the oxidative energy production during ischaemia-reperfusion and pharmacological preconditioning (PC). The selective adenine nucleotide translocator (ANT) at the inner mitochondrial membrane (IMM) regulates ATP supply to the cytoplasm in exchange for ADP, which will be regenerated to ATP in the mitochondrial matrix (MM) by the ATP synthase (ADP + Pi). The synthase is driven by the proton gradient across the IMM. The high proton concentration in the intermembrane space (MIMS) is maintained by the respiratory chain complexes (I–IV), which are energetically fuelled by the tricarboxylic acid cycle (TCAC) in the MM. On its way out of the MM, ATP passes through the ANT and enters a channel formed by an octameric complex of the mitochondrial creatine kinase (CK) where its gamma-phosphoryl is transferred to creatine (Cr) to produce creatine phosphate (CrP), which leaves the mitochondrion through the voltage-dependent anion channel (VDAC or porin) in the outer membrane (OMM) into the cytoplasm. Wherever energy is required, transphosphorylation from CrP to local ADP yields ATP for immediate use. The Cr–CK system serves as energy shuttle between the production centre and the place of consumption. The VDAC allows solutes to pass up to a molecular weight of 5000 Da. The nucleotide conductivity of ANT is controlled by cyclophilin-D (CP) at its inner opening. Binding of Ca^{2+} (which is increased during ischaemia-reperfusion) to CP induces ANT to form a non-selective channel for solutes up to a molecular weight of 1500 Da. Cyclosporin-A can bind to CP and prevents channel opening, while atractyloside binds to ANT itself and favours channel opening. During ischaemia cessation of ATP production produces a decrease of diffuse K^+ influx. Consequently, the MM shrinks somewhat at the expense of an increase of the MIMS leading to destabilization of the complex between ANT, CK and VDAC. On reperfusion additional ROS and Ca^{2+} trigger opening of the ANT channel, which then seems to join directly to the VDAC forming a non-selective mega-pore, the mPTP. This leads to the collapse of the IMM potential, to massive MM swelling and disruption of the OMM. As K^+ acts as the main MM volume regulator, activation of K^+ influx represents the most powerful mechanism to prevent mitochondrial destabilization and therewith irreversible destruction and cell death. Both ischaemic and pharmacological PC activate the mitochondrial ATP-dependent potassium channels (mK-ATP) affording myocyte protection against ischaemia-reperfusion injury. In addition, a large conductance Ca^{2+} -activated potassium channel (K-Ca) known to exist in the surface membrane of vascular smooth muscle cells was also found in the MIM. This channel is regulated by physiological variations of cytosolic Ca^{2+} , and when selectively activated, it also protects the myocytes against ischaemia-reperfusion injury.^{30 43 83 157}

explained by the observation that barbiturates competitively antagonize adenosine A_1 -receptors, a pivotal signalling pathway in cardiac preconditioning. Indeed, adenosine

receptor antagonists decrease anaesthesia-induced preconditioning.^{24 113} The same is true of PKC antagonists.¹³⁴ Albeit not proven, it may be speculated that pharmacological preconditioning by inhalation anaesthetics may be of smaller magnitude than ischaemic preconditioning.¹⁸

Pharmacological preconditioning by inhalation anaesthetics appears to be primarily mediated by stimulation of adenosine receptors¹¹³ and activation of K_{ATP} channels.^{62 113} Protective effects by inhalation anaesthetics also occur in the presence of cardioplegic protection. Ischaemic and anaesthetic-induced preconditioning are not additive suggesting the same end-effector,¹² identified in many studies as K_{ATP} channels. Nonetheless, sevoflurane can potentiate late ischaemic preconditioning in an *in vivo* rabbit model.⁸⁷ The signalling components involved in cardiac protection by inhalational anaesthetics, are similar to ischaemic preconditioning, but show distinct differences.²⁶ Both sarcolemmal and mitochondrial K_{ATP} channels may mediate anaesthesia-induced preconditioning as demonstrated in desflurane-mediated preconditioning.¹³⁵ Yet, mitochondrial K_{ATP} channels may play the more important role. Halothane partially blocks sarcolemmal K_{ATP} channels,¹¹³ while isoflurane does not. Anaesthesia-induced preconditioning is clearly species dependent. Halothane preconditions in rabbit but not rat or human. Isoflurane preconditions in rabbit and human, but not rat (for review see^{155 156}).

Anaesthetics may also modulate the effects of ischaemic preconditioning. Several anaesthetic agents have direct effects on K_{ATP} channels (barbiturates) or have prominent physiological effects that are induced by K_{ATP} channels (isoflurane, halothane).¹⁷ Accordingly, ischaemic preconditioning is abolished by glibenclamide under ketamine-xylazine anaesthesia but not pentobarbital anaesthesia. In a comparison of the effects of ischaemic preconditioning under pentobarbital, isoflurane, and ketamine-xylazine anaesthesia, infarct size was not different in the absence of preconditioning, but the magnitude of infarct size limitation by ischaemic preconditioning was different depending upon the basal anaesthesia.³⁸ In the presence of halothane anaesthesia, nicorandil given before ischaemia did not demonstrate protective effects, whereas ischaemic preconditioning did reduce infarct size. Yet, a K_{ATP} channel blocker prevented the combined effect of ischaemia and nicorandil.⁹⁰ The complexity of modulatory effects of anaesthetics on cardiac preconditioning has been substantiated in a cellular model of simulated ischaemia. Modulatory effects of anaesthetics were demonstrated by the inhibition of diazoxide-induced mitochondrial K_{ATP} channel opening by R-ketamine, thiopental and pentobarbital. Conversely, urethane, 2,2,2-trichloroethanol (a main metabolite of α -chloralose) and fentanyl potentiated the channel-opening effect of diazoxide. This potentiation could be blocked by chelerythrine, a specific PKC inhibitor. By contrast, S-ketamine, propofol, xylazine, midazolam and etomidate do not affect mitochondrial K_{ATP} channel

activity.¹⁵² These observations illustrate the complex interference of anaesthetics with ischaemic preconditioning and stress the concept of anaesthetics acting as modulators of cardiac preconditioning.

To date, there are few data on the possibility of inhalation anaesthetics conferring late preconditioning, whereas delayed protection by opioids is well established.¹²¹ Kehl and colleagues⁶⁰ examined the effect of isoflurane administration 24 h before a 60 min coronary occlusion followed by 3 h reperfusion in a canine model. While isoflurane exerted early protection, there was no late protection. By contrast, delayed preconditioning was observed in a rabbit model.¹³⁷

Finally, improved collateral blood flow may also play a role in the beneficial effects elicited by anaesthetics. Indeed, sevoflurane increases collateral flow, an effect not reversed by glibenclamide.⁶⁴ In addition, halothane, isoflurane, and sevoflurane reduce the number of neutrophils^{45,73} and platelets⁴⁴ sequestered in the coronary vasculature after ischaemia. This may contribute to the observed beneficial effects. Inhalation anaesthetics further suppress the post-ischaemic expression of CD11b⁴⁵ and thus decrease neutrophil adhesion to the endothelium.⁸⁶ However, sevoflurane does not reduce the expression of glycoprotein IIb/IIIa, a platelet adhesion molecule involved in the platelet-endothelium interaction.⁴⁴

Isoflurane

In the absence of ischaemia, isoflurane causes opening of K_{ATP} channels, an effect blocked by sulfonylureas.⁶¹ This results in a reduction in infarct size in experimental animals.⁶³ Isoflurane also decreases infarct size in an *in vitro* model of human myocardium.¹¹³ Sarcolemmal and mitochondrial K_{ATP} channels appear to be involved.^{61, 106, 113, 133, 136} Isoflurane increases the open probability of the sarcoplasmic K_{ATP} channel for a given ATP concentration.³⁹ In a cellular model, isoflurane significantly enhanced the diazoxide-mediated activation of mitochondrial K_{ATP} channels. This effect was completely blocked by chelerythrine (a PKC inhibitor). Pretreatment with inhalation anaesthetics potentiated the diazoxide-mediated protection against ischaemia. Cardioprotection was unaffected by the sarcoplasmic K_{ATP} channel blocker HMR-1098, but sensitive to modulation of nitric oxide and adenosine-Gi signalling pathways.¹⁵³ Administration of isoflurane before aortic cross-clamping in patients undergoing coronary artery bypass surgery causes cardiac index to be higher after cardiopulmonary bypass with less changes in ST-segments than in the control group. However, there were no differences in terms of arrhythmias.⁴² Thus, isoflurane may offer some additional protection to cardioplegia. These findings are consistent with the observation of lower (albeit not statistically significant) perioperative levels of CK-MB and troponin reported by Belhomme⁸ when isoflurane is used. Moreover, isoflurane was found to increase 5'-nucleotidase activity in atrial tissue indicating increased PKC activity.⁸

Sevoflurane

Sevoflurane reduces infarct size in dogs via opening of K_{ATP} channels.¹³³ Preservation of myocardial blood flow through collateral circulation, observed with sevoflurane, is independent of K_{ATP} channels. In sepsis, ultrastructural changes in the myocardium have been documented and sevoflurane protected cardiac output in septic (caecal ligation and perforation) rats.¹²⁴ Recently, the first clinical double-blinded multicentre study has shown sevoflurane to protect myocardium and kidney in patients undergoing coronary artery bypass grafting.⁵⁴ This study also visualized for the first time PKC translocation (predominantly isoforms δ and ϵ) to subcellular targets such as the sarcolemma, mitochondria, intercalated disks, and nuclei in response to sevoflurane. Moreover, the observed renoprotective effect of sevoflurane raises the intriguing possibility that systemically administered sevoflurane may confer multiorgan protection in high-risk patients.

Desflurane

In isolated human atrial trabeculae, desflurane improved the recovery of isometric contraction after a 30 min period of anoxia. The preconditioning effect of desflurane was abolished by glibenclamide, 5-hydroxydecanoate (5-HD), DPX (an adenosine receptor blocker), phentolamine, and propranolol.⁴¹ These observations suggest that preconditioning by desflurane is mediated by mitochondrial K_{ATP} channels,⁴¹ adenosine A_1 -receptors, and α - and β -adrenoceptors. In contrast, selective block of sarcolemmal K_{ATP} channels did not reduce desflurane-induced preconditioning, while it abolished anoxia-induced preconditioning. Desflurane increases sympathetic activity in volunteers and releases catecholamines from myocardial stores in rat and human myocardium.⁴⁰ Preconditioning by desflurane may thus be, at least partly, elicited by stimulation of the α/β -adrenoceptor pathways.⁷⁷

Pharmacological interventions by nonanaesthetic agents currently used for the prevention of perioperative ischaemia

Several classes of drugs have been proposed in order to reduce the risk of ischaemic complications of anaesthesia and surgery. However, based on current clinical data, only beta-blockers, α_2 -adrenoceptor agonists, and possibly statins may have the potential to affect perioperative cardiovascular outcome.

Nitroglycerin

While nitroglycerin is used successfully in the treatment of myocardial ischaemia, there is no evidence that its prophylactic administration before anaesthesia and surgery decreases the risk of perioperative cardiac complications.¹²⁷

Calcium channel blockers

Though effective in the management of ischaemic heart disease, Ca^{2+} channel blockers have never been shown to

offer any protection against perioperative cardiac complications of anaesthesia and surgery.^{126 127} This absence of protection seems surprising in view of the strong antioxidant effect of certain calcium channel blockers.¹⁴⁷

Adenosine modulators

These compounds facilitate the release of the coronary vasodilator adenosine by the ischaemic myocardium, thereby improving collateral blood flow toward the compromised area. Though promising results were obtained,⁸⁰ development of the only agent tested in clinical trials, acadesine, was stopped.

α_2 -Adrenoceptor agonists

There is renewed interest in the use of clonidine, dexmedetomidine, and (temporarily, as it is not currently being further developed for clinical use) mivazerol; these drugs reduce the level of sympathetic activity and make the circulation more stable. Clonidine decreases the risk of perioperative myocardial ischaemia⁹⁵ and a recent meta-analysis has also shown a reduction in the risk of adverse outcome.¹²⁷ Mivazerol has been tested in a large multicentre trial and was shown to decrease the incidence of cardiac complications in vascular surgical patients but not in non-vascular surgical patients,⁹⁸ yet its development was stopped.

Nicorandil

This drug is both a nitrate and a K_{ATP} channel opener. It is effective in the management of ischaemic heart disease and its associated dysrhythmias. It may prove useful in the perioperative prevention of cardiac complications.⁵⁵ In clinical practice, nicorandil, a K_{ATP} channel opener and nitrate, is widely used in the treatment of angina. Nicorandil induces myocardial preconditioning. In isolated human heart muscle nicorandil conferred cardioprotection (improved recovery of function in a hypoxia-reoxygenation model). This effect was abolished by ischaemic preconditioning.¹⁶ In a rabbit model early treatment with nicorandil (pre-ischaemia) decreased infarct size, while nicorandil administration after ischaemia was ineffective. Ischaemic preconditioning reduced infarct size and the combination of ischaemic preconditioning and nicorandil showed efficacy intermediate between ischaemic preconditioning and before administration of nicorandil.⁴⁹ The effect of nicorandil was blocked by 5-hydroxydecanoate, a K_{ATP} channel blocker. Thus, nicorandil appears to protect by opening K_{ATP} channels, and to interact with ischaemic preconditioning. By contrast, nicorandil appears to offer additional protection when administered with isoflurane, in terms of functional recovery of the stunned myocardium.¹⁰⁵

Statins

In a case-controlled study, Poldermans and colleagues¹⁰⁷ evaluated the effects of statins on perioperative mortality in patients undergoing major vascular surgery. In statin-treated patients, the risk for perioperative mortality was ~20% of that observed in non-statin-treated patients. The authors

concluded that perioperative statin use may reduce perioperative mortality in high-risk vascular patients.

β -Blockers

These drugs, at present, occupy centre stage for cardiac prophylaxis because several studies have shown a reduction in the incidence of cardiac complications of anaesthesia and surgery in patients deliberately given beta-blockers prophylactically.¹⁵⁴ The beneficial effects of perioperative β -blocker administration are discussed in detail in another article in this issue.

Conclusions

Myocardial ischaemic injury is a potential perioperative threat. Ischaemia induces a palette of myocardial states with distinct pathophysiological backgrounds ranging from the paradoxically beneficial effects of preconditioning on one side to the complete loss of cellular integrity and to cell death on the other side. Preconditioning mimicking agents such as inhalation anaesthetics and opioids induce a pronounced protective cardiac phenotype and thus may decrease, along with β -blockers, α_2 -adrenoceptor agonists, and anti-inflammatory/preconditioning-mimicking statins, the deleterious effects of myocardial ischaemia in perioperative medicine.

Acknowledgements

This work was supported by the Swiss National Science Foundation Grant 3200-063417.00 and Grant 3200B0-103980/1, the Swiss Heart Foundation, a Grant from the Swiss University Conference, and a Grant from the Hartmann-Müller Foundation, Zürich, Switzerland.

References

- 1 Afridi I, Kleiman NS, Raizner AE, Zoghbi WA. Dobutamine echocardiography in myocardial hibernation. Optimal dose and accuracy in predicting recovery of ventricular function after coronary angioplasty. *Circulation* 1995; **91**: 663–70
- 2 Aitchison KA, Baxter GF, Awan MM, et al. Opposing effects on infarction of delta and kappa opioid receptor activation in the isolated rat heart: implications for ischaemic preconditioning. *Basic Res Cardiol* 2000; **95**: 1–10
- 3 Akao M, Ohler A, O'Rourke B, Marban E. Mitochondrial ATP-sensitive potassium channels inhibit apoptosis induced by oxidative stress in cardiac cells. *Circ Res* 2001; **88**: 1267–75
- 4 Aresta F, Gerstenblith G, Weiss RG. Repeated, transient lactate exposure does not 'precondition' rat myocardium. *Can J Physiol Pharmacol* 1997; **75**: 1262–6
- 5 Ashcroft SJ, Ashcroft FM. Properties and functions of ATP-sensitive K-channels. *Cell Signal* 1990; **2**: 197–214
- 6 Baines CP, Goto M, Downey JM. Oxygen radicals released during ischemic preconditioning contribute to cardioprotection in the rabbit myocardium. *J Mol Cell Cardiol* 1997; **29**: 207–16
- 7 Bax JJ, Visser FC, Poldermans D, et al. Time course of functional recovery of stunned and hibernating segments after surgical revascularization. *Circulation* 2001; **104**: 1314–8
- 8 Belhomme D, Peynet J, Louzy M, et al. Evidence for

- preconditioning by isoflurane in coronary artery bypass graft surgery. *Circulation* 1999; **100**: 11340–4
- 9 Bolli R. Mechanism of myocardial 'stunning'. *Circulation* 1990; **82**: 723–38
 - 10 Bolli R, Triana JF, Jeroudi MO. Prolonged impairment of coronary vasodilation after reversible ischemia. Evidence for microvascular 'stunning'. *Circ Res* 1990; **67**: 332–43
 - 11 Bolli R. The late phase of preconditioning. *Circ Res* 2000; **87**: 972–83
 - 12 Boutros A, Wang J, Capuano C. Isoflurane and halothane increase adenosine triphosphate preservation, but do not provide additive recovery of function after ischemia, in preconditioned rat hearts. *Anesthesiology* 1997; **86**: 109–17
 - 13 Brady PA, Terzic A. The sulfonyleurea controversy: more questions from the heart. *J Am Coll Cardiol* 1998; **31**: 950–6
 - 14 Braunwald E, Kloner RA. The stunned myocardium: prolonged, postischemic ventricular dysfunction. *Circulation* 1982; **66**: 1146–9
 - 15 Brew EC, Mitchell MB, Rehring TF, et al. Role of bradykinin in cardiac functional protection after global ischemia-reperfusion in rat heart. *Am J Physiol* 1995; **269**: H1370–8
 - 16 Carr CS, Yellon DM. Ischaemic preconditioning may abolish the protection afforded by ATP-sensitive potassium channel openers in isolated human atrial muscle. *Basic Res Cardiol* 1997; **92**: 252–60
 - 17 Cason BA, Gordon HJ, Avery EG, Hickey RF. The role of ATP sensitive potassium channels in myocardial protection. *J Card Surg* 1995; **10**: 441–4
 - 18 Cason BA, Gamperl AK, Slocum RE, Hickey RF. Anesthetic-induced preconditioning: previous administration of isoflurane decreases myocardial infarct size in rabbits. *Anesthesiology* 1997; **87**: 1182–90
 - 19 Cave AC, Collis CS, Downey JM, Hearse DJ. Improved functional recovery by ischaemic preconditioning is not mediated by adenosine in the globally ischaemic isolated rat heart. *Cardiovasc Res* 1993; **27**: 663–8
 - 20 Chien GL, Mohtadi K, Wolff RA, Van Winkle DM. Naloxone blockade of myocardial ischemic preconditioning does not require central nervous system participation. *Basic Res Cardiol* 1999; **94**: 136–43
 - 21 Cleveland JC Jr, Meldrum DR, Cain BS, Banerjee A, Harken AH. Oral sulfonyleurea hypoglycemic agents prevent ischemic preconditioning in human myocardium. Two paradoxes revisited. *Circulation* 1997; **96**: 29–32
 - 22 Coetzee A, Moolman J. Halothane and the reperfusion injury in the intact animal model. *Anesth Analg* 1993; **76**: 734–44
 - 23 Coetzee A. Comparison of the effects of propofol and halothane on acute myocardial ischaemia and myocardial reperfusion injury. *S Afr Med J* 1996; **86** (Suppl. 2): C85–90
 - 24 Cope DK, Impastato WK, Cohen MV, Downey JM. Volatile anesthetics protect the ischemic rabbit myocardium from infarction. *Anesthesiology* 1997; **86**: 699–709
 - 25 Csonka C, Szilvassy Z, Fulop F, et al. Classic preconditioning decreases the harmful accumulation of nitric oxide during ischemia and reperfusion in rat hearts. *Circulation* 1999; **100**: 2260–6
 - 26 Da Silva R, Grampp T, Pasch T, Schaub MC, Zaugg M. Differential activation of mitogen-activated protein kinases in ischemic and anesthetic preconditioning. *Anesthesiology* 2004; **100**: 59–69
 - 27 De Hert SG, Cromheecke S, ten Broecke PW, et al. Effects of propofol, desflurane, and sevoflurane on recovery of myocardial function after coronary surgery in elderly high-risk patients. *Anesthesiology* 2003; **99**: 314–23
 - 28 Deutsch E, Berger M, Kussmaul WG, et al. Adaptation to ischemia during percutaneous transluminal coronary angioplasty. Clinical, hemodynamic, and metabolic features. *Circulation* 1990; **82**: 2044–51
 - 29 Doenst T, Guthrie PH, Chemnitz JM, Zech R, Taegtmeyer H. Fasting, lactate, and insulin improve ischemia tolerance in rat heart: a comparison with ischemic preconditioning. *Am J Physiol* 1996; **270**: H1607–15
 - 30 Dolder M, Wendt S, Wallimann T. Mitochondrial creatine kinase in contact sites: interaction with porin and adenine nucleotide translocase, role in permeability transition and sensitivity to oxidative damage. *Biol Signals Recept* 2001; **10**: 93–111
 - 31 Downey JM, Cohen MV. Signal transduction in ischemic preconditioning. *Adv Exp Med Biol* 1997; **430**: 39–55
 - 32 Duncker DJ, McFalls EO, Krams R, Verdouw PD. Pressure-maximal coronary flow relationship in regionally stunned porcine myocardium. *Am J Physiol* 1992; **262**: H1744–51
 - 33 Ferdinandy P, Szilvassy Z, Balogh N, et al. Nitric oxide is involved in active preconditioning in isolated working rat hearts. *Ann N Y Acad Sci* 1996; **793**: 489–93
 - 34 Frances C, Nazeyrollas P, Prevost A, et al. Role of β_1 - and β_2 -adrenoceptor subtypes in preconditioning against myocardial dysfunction after ischemia and reperfusion. *J Cardiovasc Pharmacol* 2003; **41**: 396–405
 - 35 Garlid KD, Paucek P, Yarov Yarovoy V, et al. Cardioprotective effect of diazoxide and its interaction with mitochondrial ATP-sensitive K^+ channels. Possible mechanism of cardioprotection. *Circ Res* 1997; **81**: 1072–82
 - 36 Goto M, Liu Y, Yang XM, et al. Role of bradykinin in protection of ischemic preconditioning in rabbit hearts. *Circ Res* 1995; **77**: 611–21
 - 37 Gunaydin B, Cakici I, Soncul H, et al. Does remote organ ischaemia trigger cardiac preconditioning during coronary artery surgery? *Pharmacol Res* 2000; **41**: 493–6
 - 38 Haessler R, Kuzume K, Chien GL, et al. Anaesthetics alter the magnitude of infarct limitation by ischaemic preconditioning. *Cardiovasc Res* 1994; **28**: 1574–80
 - 39 Han J, Kim E, Ho WK, Earm YE. Effects of volatile anesthetic isoflurane on ATP-sensitive K^+ channels in rabbit ventricular myocytes. *Biochem Biophys Res Commun* 1996; **229**: 852–6
 - 40 Hanouz JL, Massetti M, Guesne G, et al. *In vitro* effects of desflurane, sevoflurane, isoflurane, and halothane in isolated human right atria. *Anesthesiology* 2000; **92**: 116–24
 - 41 Hanouz JL, Yvon A, Massetti M, et al. Mechanisms of desflurane-induced preconditioning in isolated human right atria *in vitro*. *Anesthesiology* 2002; **97**: 33–41
 - 42 Haroun Bizri S, Khoury SS, Chehab IR, Kassas CM, Baraka A. Does isoflurane optimize myocardial protection during cardiopulmonary bypass? *J Cardiothorac Vasc Anesth* 2001; **15**: 418–21
 - 43 Hausenloy DJ, Maddock HL, Baxter GF, Yellon DM. Inhibiting mitochondrial permeability transition pore opening: a new paradigm for myocardial preconditioning? *Cardiovasc Res* 2002; **55**: 534–43
 - 44 Heindl B, Conzen PF, Becker BF. The volatile anesthetic sevoflurane mitigates cardiodepressive effects of platelets in reperfused hearts. *Basic Res Cardiol* 1999; **94**: 102–11
 - 45 Heindl B, Reichle FM, Zahler S, Conzen PF, Becker BF. Sevoflurane and isoflurane protect the reperfused guinea pig heart by reducing postischemic adhesion of polymorphonuclear neutrophils. *Anesthesiology* 1999; **91**: 521–30
 - 46 Hill M, Takano H, Tang XL, et al. Nitroglycerin induces late preconditioning against myocardial infarction in conscious rabbits despite development of nitrate tolerance. *Circulation* 2001; **104**: 694–9

- 47 Iliodromitis EK, Kremastinos DT, Katritsis DG, Papadopoulos CC, Hearse DJ. Multiple cycles of preconditioning cause loss of protection in open-chest rabbits. *J Mol Cell Cardiol* 1997; **29**: 915–20
- 48 Illes RW, Wright JK, Inners McBride K, Yang CJ, Tristan A. Ischemic preconditioning improves preservation with crystalloid cardioplegia. *Ann Thorac Surg* 1994; **58**: 1481–5
- 49 Imagawa J, Baxter GF, Yellon DM. Myocardial protection afforded by nicorandil and ischaemic preconditioning in a rabbit infarct model *in vivo*. *J Cardiovasc Pharmacol* 1998; **31**: 74–9
- 50 Ismaeil MS, Tkachenko I, Hickey RF, Cason BA. Colchicine inhibits isoflurane-induced preconditioning. *Anesthesiology* 1999; **91**: 1816–22
- 51 Jenkins DP, Pugsley WB, Alkhulaifi AM, et al. Ischaemic preconditioning reduces troponin T release in patients undergoing coronary artery bypass surgery. *Heart* 1997; **77**: 314–18
- 52 Joyeux M, Arnaud C, Godin-Ribuot D, et al. Endocannabinoids are implicated in the infarct size-reducing effect conferred by heat stress preconditioning in isolated rat hearts. *Cardiovasc Res* 2002; **55**: 619–25
- 53 Jugdutt BI. Different relations between infarct size and occluded bed size in barbiturate-anesthetized versus conscious dogs. *J Am Coll Cardiol* 1985; **6**: 1035–46
- 54 Julier K, da Silva R, Garcia C, et al. Preconditioning by sevoflurane decreases biochemical markers for myocardial and renal dysfunction in coronary artery bypass graft surgery: a double-blinded, placebo-controlled, multicenter study. *Anesthesiology* 2003; **98**: 1315–27
- 55 Kaneko T, Saito Y, Hikawa Y, Yasuda K, Makita K. Dose-dependent prophylactic effect of nicorandil, an ATP-sensitive potassium channel opener, on intra-operative myocardial ischaemia in patients undergoing major abdominal surgery. *Br J Anaesth* 2001; **86**: 332–7
- 56 Kato R, Foëx P. Fentanyl reduces infarction but not stunning via δ -opioid receptors and protein kinase C in rats. *Br J Anaesth* 2000; **84**: 608–14
- 57 Kato R, Ross S, Foëx P. Fentanyl protects the heart against ischaemic injury via opioid receptors, adenosine A_1 receptors and K_{ATP} channel linked mechanisms in rats. *Br J Anaesth* 2000; **84**: 204–14
- 58 Kato R, Foëx P. Myocardial protection by anesthetic agents against ischemia-reperfusion injury: an update for anesthesiologists. *Can J Anaesth* 2002; **49**: 777–91
- 59 Kaukoranta PK, Lepojarvi MP, Ylitalo KV, Kiviluoma KT, Peuhkurinen KJ. Normothermic retrograde blood cardioplegia with or without preceding ischemic preconditioning. *Ann Thorac Surg* 1997; **63**: 1268–74
- 60 Kehl F, Pagel P-S, Krolikowski J-G, et al. Isoflurane does not produce a second window of preconditioning against myocardial infarction *in vivo*. *Anesth Analg* 2002; **95**: 1162–8
- 61 Kersten JR, Lowe D, Hettrick DA, et al. Glyburide, a K_{ATP} channel antagonist, attenuates the cardioprotective effects of isoflurane in stunned myocardium. *Anesth Analg* 1996; **83**: 27–33
- 62 Kersten JR, Schmeling TJ, Hettrick DA, et al. Mechanism of myocardial protection by isoflurane. Role of adenosine triphosphate-regulated potassium K_{ATP} channels. *Anesthesiology* 1996; **85**: 794–807
- 63 Kersten JR, Schmeling TJ, Pagel PS, Gross GJ, Warltier DC. Isoflurane mimics ischemic preconditioning via activation of K_{ATP} channels: reduction of myocardial infarct size with an acute memory phase. *Anesthesiology* 1997; **87**: 361–70
- 64 Kersten JR, Schmeling T, Tessmer J, et al. Sevoflurane selectively increases coronary collateral blood flow independent of K_{ATP} channels *in vivo*. *Anesthesiology* 1999; **90**: 246–56
- 65 Keung EC, Li Q. Lactate activates ATP-sensitive potassium channels in guinea pig ventricular myocytes. *J Clin Invest* 1991; **88**: 1772–7
- 66 Kharbanda RK, Mortensen UM, White PA, et al. Transient limb ischemia induces remote ischemic preconditioning *in vivo*. *Circulation* 2002; **106**: 2881–3
- 67 Kim SJ, Depre C, Vatner SF. Novel mechanisms mediating stunned myocardium. *Heart Fail Rev* 2003; **8**: 143–53
- 68 Kirsch GE, Codina J, Birnbaumer L, Brown AM. Coupling of ATP-sensitive K^+ channels to A1 receptors by G proteins in rat ventricular myocytes. *Am J Physiol* 1990; **259**: H820–6
- 69 Kloner RA, Shook T, Przyklenk K, et al. Previous angina alters in-hospital outcome in TIMI 4. A clinical correlate to preconditioning? *Circulation* 1995; **91**: 37–45
- 70 Ko SH, Yu CW, Lee SK, et al. Propofol attenuates ischemia-reperfusion injury in the isolated rat heart. *Anesth Analg* 1997; **85**: 719–24
- 71 Kokita N, Hara A, Abiko Y, et al. Propofol improves functional and metabolic recovery in ischemic reperfused isolated rat hearts. *Anesth Analg* 1998; **86**: 252–8
- 72 Kolocassides KG, Galinanes M, Hearse DJ. Ischemic preconditioning, cardioplegia or both? *J Mol Cell Cardiol* 1994; **26**: 1411–14
- 73 Kowalski C, Zahler S, Becker BF, et al. Halothane, isoflurane, and sevoflurane reduce postischemic adhesion of neutrophils in the coronary system. *Anesthesiology* 1997; **86**: 188–95
- 74 Lagneux C, Lamontagne D. Involvement of cannabinoids in the cardioprotection induced by lipopolysaccharide. *Br J Pharmacol* 2001; **132**: 793–6
- 75 Liang BT, Gross GJ. Direct preconditioning of cardiac myocytes via opioid receptors and K_{ATP} channels. *Circ Res* 1999; **84**: 1396–400
- 76 Liu H, McPherson BC, Yao Z. Preconditioning attenuates apoptosis and necrosis: role of protein kinase C ϵ and $-\delta$ isoforms. *Am J Physiol Heart Circ Physiol* 2001; **281**: H404–10
- 77 Lochner A, Genade S, Tromp E, Podzuweit T, Moolman JA. Ischemic preconditioning and the beta-adrenergic signal transduction pathway. *Circulation* 1999; **100**: 958–66
- 78 Louie HW, Laks H, Milgalter E, et al. Ischemic cardiomyopathy. Criteria for coronary revascularization and cardiac transplantation. *Circulation* 1991; **84**: III290–5
- 79 Ludmer PL, Selwyn AP, Shook TL, et al. Paradoxical vasoconstriction induced by acetylcholine in atherosclerotic coronary arteries. *N Engl J Med* 1986; **315**: 1046–51
- 80 Mangano DT. Effects of acadesine on myocardial infarction, stroke, and death following surgery. A meta-analysis of the 5 international randomized trials. The Multicenter Study of Perioperative Ischemia (McSPI) Research Group. *JAMA* 1997; **277**: 325–32
- 81 Marsch SC, Wanigasekera VA, Ryder WA, Wong LS, Foëx P. Graded myocardial ischemia is associated with a decrease in diastolic distensibility of the remote nonischemic myocardium in the anesthetized dog. *J Am Coll Cardiol* 1993; **22**: 899–906
- 82 Mathur S, Farhangkhgoee P, Karmazyn M. Cardioprotective effects of propofol and sevoflurane in ischemic and reperfused rat hearts: role of K_{ATP} channels and interaction with the sodium-hydrogen exchange inhibitor HOE 642 (cariporide). *Anesthesiology* 1999; **91**: 1349–60
- 83 Mayer B, Oberbauer R. Mitochondrial regulation of apoptosis. *News Physiol Sci* 2003; **18**: 89–94
- 84 Miki T, Cohen MV, Downey JM. Opioid receptor contributes to

- ischemic preconditioning through protein kinase C activation in rabbits. *Mol Cell Biochem* 1998; **186**: 3–12
- 85 Miyawaki H, Ashraf M. Ca^{2+} as a mediator of ischemic preconditioning. *Circ Res* 1997; **80**: 790–9
- 86 Mobert J, Zahler S, Becker BF, Conzen PF. Inhibition of neutrophil activation by volatile anesthetics decreases adhesion to cultured human endothelial cells. *Anesthesiology* 1999; **90**: 1372–81
- 87 Mullenheim J, Ebel D, Bauer M, et al. Sevoflurane confers additional cardioprotection after ischemic late preconditioning in rabbits. *Anesthesiology* 2003; **99**: 624–31
- 88 Murphy AM, Kogler H, Georgakopoulos D, et al. Transgenic mouse model of stunned myocardium. *Science* 2000; **287**: 488–91
- 89 Murry CE, Jennings RB, Reimer KA. Preconditioning with ischemia: a delay of lethal cell injury in ischemic myocardium. *Circulation* 1986; **74**: 1124–36
- 90 Nakae I, Takaoka A, Mitsunami K, et al. Cardioprotective effects of nicorandil in rabbits anaesthetized with halothane: potentiation of ischaemic preconditioning via K_{ATP} channels. *Clin Exp Pharmacol Physiol* 2000; **27**: 810–17
- 91 Napoli C, Liguori A, Chiariello M, et al. New-onset angina preceding acute myocardial infarction is associated with improved contractile recovery after thrombolysis. *Eur Heart J* 1998; **19**: 411–19
- 92 Narayan P, Mentzer RM Jr, Lasley RD. Adenosine A1 receptor activation reduces reactive oxygen species and attenuates stunning in ventricular myocytes. *J Mol Cell Cardiol* 2001; **33**: 121–9
- 93 NCEPOD. Extremes of Age. The 1999 Report of the National Confidential Enquiry into Perioperative Deaths, 1999; www.ncepod.org.uk
- 94 NCEPOD. Then and Now: The 2000 Report of the National Confidential Enquiry into Postoperative Deaths, 2001; www.ncepod.org.uk
- 95 Nishina K, Mikawa K, Uesugi T, et al. Efficacy of clonidine for prevention of perioperative myocardial ischemia: a critical appraisal and meta-analysis of the literature. *Anesthesiology* 2002; **96**: 323–9
- 96 Noma A. ATP-regulated K^+ channels in cardiac muscle. *Nature* 1983; **305**: 147–8
- 97 Oguchi T, Kashimoto S, Yamaguchi T, Nakamura T, Kumazawa T. Comparative effects of halothane, enflurane, isoflurane and sevoflurane on function and metabolism in the ischaemic rat heart. *Br J Anaesth* 1995; **74**: 569–75
- 98 Oliver MF, Goldman L, Julian DG, Holme I. Effect of mivazerol on perioperative cardiac complications during non-cardiac surgery in patients with coronary heart disease: the European Mivazerol Trial (EMIT). *Anesthesiology* 1999; **91**: 951–61
- 99 O'Neill CA, Fu LW, Halliwell B, Longhurst JC. Hydroxyl radical production during myocardial ischemia and reperfusion in cats. *Am J Physiol* 1996; **271**: H660–7
- 100 Ottani F, Galvani M, Ferrini D, Nicolini FA. Clinical relevance of prodromal angina before acute myocardial infarction. *Int J Cardiol* 1999; **68** (Suppl. 1): S103–8
- 101 Ovize M, Przyklenk K, Hale SL, Kloner RA. Preconditioning does not attenuate myocardial stunning. *Circulation* 1992; **85**: 2247–54
- 102 Perrault LP, Menasche P, Bel A, et al. Ischemic preconditioning in cardiac surgery: a word of caution. *J Thorac Cardiovasc Surg* 1996; **112**: 1378–86
- 103 Piomelli D, Giuffrida A, Calignano A, Rodriguez de Fonseca F. The endocannabinoid system as a target for therapeutic drugs. *Trends Pharmacol Sci* 2000; **21**: 218–24
- 104 Piper HM, Meuter K, Schafer C. Cellular mechanisms of ischemia-reperfusion injury. *Ann Thorac Surg* 2003; **75**: S644–8
- 105 Piriou V, Ross S, Pigott D, Evans R, Foëx P. Beneficial effect of concomitant administration of isoflurane and nicorandil. *Br J Anaesth* 1997; **79**: 68–77
- 106 Piriou V, Chiari P, Knezynski S, et al. Prevention of isoflurane-induced preconditioning by 5-hydroxydecanoate and gadolinium: possible involvement of mitochondrial adenosine triphosphate-sensitive potassium and stretch-activated channels. *Anesthesiology* 2000; **93**: 756–64
- 107 Poldermans D, Bax JJ, Kertai MD, et al. Statins are associated with a reduced incidence of perioperative mortality in patients undergoing major noncardiac vascular surgery. *Circulation* 2003; **107**: 1848–51
- 108 Preckel B, Schlack W, Comfere T, et al. Effects of enflurane, isoflurane, sevoflurane and desflurane on reperfusion injury after regional myocardial ischaemia in the rabbit heart *in vivo*. *Br J Anaesth* 1998; **81**: 905–12
- 109 Preckel B, Thamer V, Schlack W. Beneficial effects of sevoflurane and desflurane against myocardial reperfusion injury after cardioplegic arrest. *Can J Anaesth* 1999; **46**: 1076–81
- 110 Rahimtoola SH. A perspective on the three large multicenter randomized clinical trials of coronary bypass surgery for chronic stable angina. *Circulation* 1985; **72**: V123–35
- 111 Rahimtoola SH. The hibernating myocardium. *Am Heart J* 1989; **117**: 211–21
- 112 Reimer KA, Murry CE, Yamasawa I, Hill ML, Jennings RB. Four brief periods of myocardial ischemia cause no cumulative ATP loss or necrosis. *Am J Physiol* 1986; **251**: H1306–15
- 113 Roscoe AK, Christensen JD, Lynch C, 3rd. Isoflurane, but not halothane, induces protection of human myocardium via adenosine A1 receptors and adenosine triphosphate-sensitive potassium channels. *Anesthesiology* 2000; **92**: 1692–701
- 114 Ross S, Munoz H, Piriou V, Ryder WA, Foëx P. A comparison of the effects of fentanyl and propofol on left ventricular contractility during myocardial stunning. *Acta Anaesthesiol Scand* 1998; **42**: 23–31
- 115 Ross S, Foëx P. Protective effects of anaesthetics in reversible and irreversible ischaemia-reperfusion injury. *Br J Anaesth* 1999; **82**: 622–32
- 116 Rubino A, Yellon DM. Ischaemic preconditioning of the vasculature: an overlooked phenomenon for protecting the heart? *Trends Pharmacol Sci* 2000; **21**: 225–30
- 117 Sahlman L, Waagstein L, Haljamae H, Ricksten SE. Protective effects of halothane but not isoflurane against global ischaemic injury in the isolated working rat heart. *Acta Anaesthesiol Scand* 1995; **39**: 312–16
- 118 Samaha FF, Heineman FW, Ince C, Fleming J, Balaban RS. ATP-sensitive potassium channel is essential to maintain basal coronary vascular tone *in vivo*. *Am J Physiol* 1992; **262**: C1220–7
- 119 Schlack W, Preckel B, Stunneck D, Thamer V. Effects of halothane, enflurane, isoflurane, sevoflurane and desflurane on myocardial reperfusion injury in the isolated rat heart. *Br J Anaesth* 1998; **81**: 913–19
- 120 Schultz JE, Hsu AK, Gross GJ. Morphine mimics the cardioprotective effect of ischemic preconditioning via a glibenclamide-sensitive mechanism in the rat heart. *Circ Res* 1996; **78**: 1100–4
- 121 Schultz JE, Gross GJ. Opioids and cardioprotection. *Pharmacol Ther* 2001; **89**: 123–37
- 122 Schultz JJ, Hsu AK, Gross GJ. Ischemic preconditioning is mediated by a peripheral opioid receptor mechanism in the intact rat heart. *J Mol Cell Cardiol* 1997; **29**: 1355–62
- 123 Schultz JJ, Hsu AK, Gross GJ. Ischemic preconditioning and

- morphine-induced cardioprotection involve the delta (δ)-opioid receptor in the intact rat heart. *J Mol Cell Cardiol* 1997; **29**: 2187–95
- 124 Serita R, Morisaki H, Ai K, et al. Sevoflurane preconditions stunned myocardium in septic but not healthy isolated rat hearts. *Br J Anaesth* 2002; **89**: 896–903
- 125 Sharma HS, Das DK, Verdouw PD. Enhanced expression and localization of heme oxygenase-I during recovery phase of porcine stunned myocardium. *Mol Cell Biochem* 1999; **196**: 133–9
- 126 Slogoff S, Keats AS. Does chronic treatment with calcium entry blocking drugs reduce perioperative myocardial ischemia? *Anesthesiology* 1988; **68**: 676–80
- 127 Stevens RD, Burri H, Tramer MR. Pharmacologic myocardial protection in patients undergoing noncardiac surgery: a quantitative systematic review. *Anesth Analg* 2003; **97**: 623–33
- 128 Szekely A, Heindl B, Zahler S, Conzen PF, Becker BF. Nonuniform behavior of intravenous anesthetics on postischemic adhesion of neutrophils in the guinea pig heart. *Anesth Analg* 2000; **90**: 1293–300
- 129 Takano H, Manchikalapudi S, Tang XL, et al. Nitric oxide synthase is the mediator of late preconditioning against myocardial infarction in conscious rabbits. *Circulation* 1998; **98**: 441–9
- 130 Takano H, Tang XL, Qiu Y, et al. Nitric oxide donors induce late preconditioning against myocardial stunning and infarction in conscious rabbits via an antioxidant-sensitive mechanism. *Circ Res* 1998; **83**: 73–84
- 131 Takasaki Y, Wolff RA, Chien GL, van Winkle DM. Met5-enkephalin protects isolated adult rabbit cardiomyocytes via delta-opioid receptors. *Am J Physiol* 1999; **277**: H2442–50
- 132 Thornton JD, Daly JF, Cohen MV, Yang XM, Downey JM. Catecholamines can induce adenosine receptor-mediated protection of the myocardium but do not participate in ischemic preconditioning in the rabbit. *Circ Res* 1993; **73**: 649–55
- 133 Toller WG, Kersten JR, Pagel PS, Hettrick DA, Warltier DC. Sevoflurane reduces myocardial infarct size and decreases the time threshold for ischemic preconditioning in dogs. *Anesthesiology* 1999; **91**: 1437–46
- 134 Toller WG, Montgomery MW, Pagel PS, et al. Isoflurane-enhanced recovery of canine stunned myocardium: role for protein kinase C? *Anesthesiology* 1999; **91**: 713–22
- 135 Toller WG, Gross ER, Kersten JR, et al. Sarcolemmal and mitochondrial adenosine triphosphate-dependent potassium channels: mechanism of desflurane-induced cardioprotection. *Anesthesiology* 2000; **92**: 1731–9
- 136 Toller WG, Kersten JR, Gross ER, Pagel PS, Warltier DC. Isoflurane preconditions myocardium against infarction via activation of inhibitory guanine nucleotide binding proteins. *Anesthesiology* 2000; **92**: 1400–7
- 137 Tonkovic-Capin M, Gross GJ, Bosnjak ZJ, et al. Delayed cardioprotection by isoflurane: role of K_{ATP} channels. *Am J Physiol Heart Circ Physiol* 2002; **283**: H61–8
- 138 Triana JF, Li XY, Jamaluddin U, Thornby JL, Bolli R. Postischemic myocardial ‘stunning’. Identification of major differences between the open-chest and the conscious dog and evaluation of the oxygen radical hypothesis in the conscious dog. *Circ Res* 1991; **69**: 731–47
- 139 Uecker M, Da Silva R, Grampp T, et al. Translocation of protein kinase C isoforms to subcellular targets in ischemic and anesthetic preconditioning. *Anesthesiology* 2003; **99**: 138–147
- 140 Wang TL, Chang H, Hung CR, Tseng YZ. Attenuation of neutrophil and endothelial activation by intravenous morphine in patients with acute myocardial infarction. *Am J Cardiol* 1997; **80**: 1532–5
- 141 Wang Y, Ashraf M. Role of protein kinase C in mitochondrial K_{ATP} channel-mediated protection against Ca^{2+} overload injury in rat myocardium. *Circ Res* 1999; **84**: 1156–65
- 142 Warltier DC, al-Wathiqui MH, Kampine JP, Schmeling WT. Recovery of contractile function of stunned myocardium in chronically instrumented dogs is enhanced by halothane or isoflurane. *Anesthesiology* 1988; **69**: 552–65
- 143 Weber TP, Meissner A, Boknik P, et al. Hemin, inducer of heme-oxygenase I, improves functional recovery from myocardial stunning in conscious dogs. *J Cardiothorac Vasc Anesth* 2001; **15**: 422–7
- 144 White JL, Myers AK, Analoui A, Kim YD. Functional recovery of stunned myocardium is greater with halothane than fentanyl anaesthesia in dogs. *Br J Anaesth* 1994; **73**: 214–19
- 145 Wu ZK, Iivainen T, Pehkonen E, Laurikka J, Tarkka MR. Ischemic preconditioning suppresses ventricular tachyarrhythmias after myocardial revascularization. *Circulation* 2002; **106**: 3091–6
- 146 Xuan YT, Tang XL, Qiu Y, et al. Biphasic response of cardiac NO synthase isoforms to ischemic preconditioning in conscious rabbits. *Am J Physiol Heart Circ Physiol* 2000; **279**: H2360–71
- 147 Yao K, Ina Y, Sonoda R, et al. Protective effects of benidipine on hydrogen peroxide-induced injury in rat isolated hearts. *J Pharm Pharmacol* 2003; **55**: 109–14
- 148 Yellon DM, Alkhulaifi AM, Pugsley WB. Preconditioning the human myocardium. *Lancet* 1993; **342**: 276–7
- 149 Yet SF, Perrella MA, Layne MD, et al. Hypoxia induces severe right ventricular dilatation and infarction in heme oxygenase-I null mice. *J Clin Invest* 1999; **103**: R23–9
- 150 Ytrehus K, Liu Y, Downey JM. Preconditioning protects ischemic rabbit heart by protein kinase C activation. *Am J Physiol* 1994; **266**: H1145–52
- 151 Zaugg M, Jamali NZ, Lucchinetti E, Shafiq SA, Siddiqui MA. Norepinephrine-induced apoptosis is inhibited in adult rat ventricular myocytes exposed to volatile anesthetics. *Anesthesiology* 2000; **93**: 209–18
- 152 Zaugg M, Lucchinetti E, Spahn D-R, et al. Differential effects of anesthetics on mitochondrial K_{ATP} channel activity and cardiomyocyte protection. *Anesthesiology* 2002; **97**: 15–23
- 153 Zaugg M, Lucchinetti E, Spahn DR, Pasch T, Schaub MC. Volatile anesthetics mimic cardiac preconditioning by priming the activation of mitochondrial K_{ATP} channels via multiple signaling pathways. *Anesthesiology* 2002; **97**: 4–14
- 154 Zaugg M, Schaub MC, Pasch T, Spahn DR. Modulation of beta-adrenergic receptor subtype activities in perioperative medicine: mechanisms and sites of action. *Br J Anaesth* 2002; **88**: 101–23
- 155 Zaugg M, Lucchinetti E, Garcia C, et al. Anaesthetics and cardiac preconditioning. Part II. Clinical implications. *Br J Anaesth* 2003; **91**: 566–76
- 156 Zaugg M, Lucchinetti E, Uecker M, Pasch T, Schaub MC. Anaesthetics and cardiac preconditioning. Part I. Signalling and cytoprotective mechanisms. *Br J Anaesth* 2003; **91**: 551–65
- 157 Zaugg M, Schaub MC. Signaling and cellular mechanisms in cardiac protection by ischemic and pharmacological preconditioning. *J Muscle Res Cell Motil* 2003; **24**: 219–49