

Advance Access publication September 7, 2006.

# WNT4 deficiency—a clinical phenotype distinct from the classic Mayer–Rokitansky–Kuster–Hauser syndrome: A Case Report

A.Biason-Lauber<sup>1,3</sup>, G.De Filippo<sup>2</sup>, D.Konrad<sup>1</sup>, G.Scarano<sup>2</sup>, A.Nazzaro<sup>2</sup> and E.J.Schoenle<sup>1</sup>

<sup>1</sup>University Children's Hospital, Zurich, Switzerland and <sup>2</sup>Gaetano Rummo Hospital, Benevento, Italy

<sup>3</sup>To whom correspondence should be addressed at: University Children's Hospital, Steinwiesstrasse 75, 8032 Zurich, Switzerland.  
E-mail: [anna.lauber@kispi.unizh.ch](mailto:anna.lauber@kispi.unizh.ch)

**The pathways leading to female sexual determination in mammals are incompletely defined. Loss-of-function mutations in the *WNT4* gene appear to cause developmental abnormalities of sexual differentiation in women and mice. We recruited six patients with different degrees of Müllerian abnormalities, with or without renal aberrations and a normal female 46,XX karyotype. A clear androgen excess was found only in one patient. This 19-year-old woman was affected by primary amenorrhoea, absence of Müllerian ducts derivatives, clinical (acne and hirsutism) and biochemical (repeatedly high levels of testosterone) signs of androgen excess. Direct sequencing of her *WNT4* gene followed by functional studies in human ovarian cells (OVCAR3) was performed. This patient carried the novel R83C loss-of-function dominant negative mutation in her *WNT4*, confirming the role of *WNT4* in the development and maintenance of the female phenotype in women. Our study can also help refine the phenotype of *WNT4* deficiency in humans. In fact, it appears that at least in this limited casuistic small group of patients, the absence of a uterus (and not other Müllerian abnormalities) and the androgen excess are the pathognomonic signs of *WNT4* defects, suggesting that this might be a clinical entity distinct from the classic Mayer–Rokitansky–Kuster–Hauser syndrome.**

*Key words:* gonad/Mayer–Rokitansky–Kuster–Hauser syndrome/sex determination/WNT

## Introduction

Differentiation of a testis or an ovary from the bipotential gonad is a complex developmental process involving various genes and hormones (MacLaughlin and Donahoe, 2004). This is the primary step in sex determination in mammals, including humans. Several genes have been identified as being essential for the early steps of sexual development in males and females (Luo *et al.*, 1994; Miyamoto *et al.*, 1997; Katoh-Fukui *et al.*, 1998; Birk *et al.*, 2000; Hammes *et al.*, 2001). Factors involved in male sex differentiation are well studied, whereas the pathways that regulate female sexual differentiation remain incompletely defined. *Wnt4*, one of a few factors with a demonstrated function in the ovarian determination pathway, has been implicated in sex differentiation in mice (Vainio *et al.*, 1999; Jeays-Ward *et al.*, 2004). *Wnt4*, a secreted protein that acts as a repressor of the male differentiation (Jordan *et al.*, 2001; Jeays-Ward *et al.*, 2003), is a member of the *Wnt* family of secreted molecules that function in a paracrine manner to effect several developmental changes. *Wnts* bind to members of the Frizzled family of cell surface receptors and activate a cascade of intracellular signals leading to the transcriptional activation of target genes. The pathway downstream *WNT4* operates via follistatin, and it has both anti-testis (inhibition of

the coelomic vessels) and pro-ovary function (support of germ cells) (Yao *et al.*, 2004). The role of *WNT4* in female sexual differentiation was confirmed in humans by the description of a loss-of-function mutation in *WNT4* gene causing developmental abnormalities of sexual differentiation in women (Biason-Lauber *et al.*, 2004). To corroborate the role of *WNT4* in sexual determination in women and to better define the clinical phenotype of *WNT4* deficiency, we looked for mutations in the *WNT4* gene in a limited cohort of 46,XX patients affected by abnormalities of Müllerian ducts with or without renal and gonadal involvement.

## Patients and methods

### Case report

Six patients (age 6 months to 20 years) with different degrees of Müllerian abnormalities (uterine agenesis  $n = 4$  and uterus didelphys, i.e. double uterus with double cervix and double vagina, caused by a failure of the Müllerian ducts to unite  $n = 2$ ), without ( $n = 2$ ) or with renal abnormalities ( $n = 4$ : renal agenesis  $n = 2 / 4$ ; renal dysplasia  $n = 2 / 4$ ). Their karyotype was 46,XX. A clear androgen excess was found only in one patient. This 19.5-year-old woman was referred for primary amenorrhoea and dysmorphic features. She was the seventh

child of apparently unrelated parents (father 38 and mother 42 years old) and had two healthy sisters (one with two children) and a brother with behavioural problems. One sister died at 5 months of age and two twins shortly after birth for unspecified reasons (Figure 1). Adrenarche

occurred at 10 years, thelarche 1 year later. Breast and pubic-hair development progressed normally (Tanner stage 5). At physical examination, she was obese and short (69.2 kg; 148.6 cm; BMI 31.59 kg/m<sup>2</sup>) with dysmorphic features (anterior hairline, bushy

A

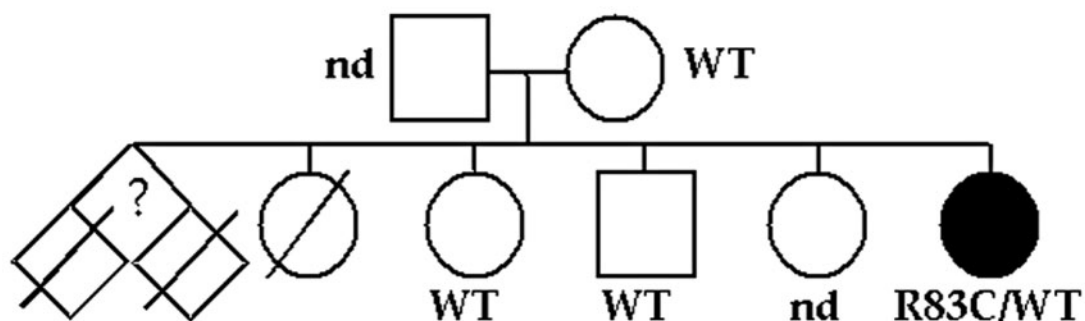

B

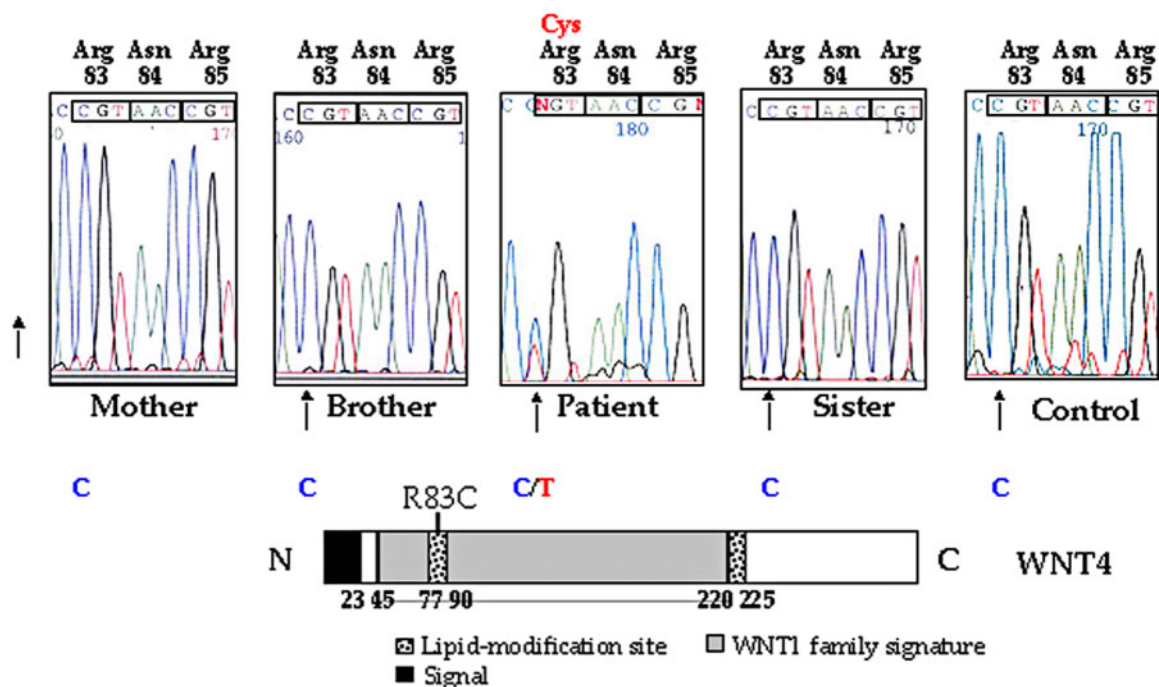

C

human ----LIQRQVQMC<sup>R</sup>KRNLEVMD<sup>S</sup>VR<sup>R</sup>GQA<sup>L</sup>AI<sup>E</sup>EC<sup>Q</sup>Y<sup>Q</sup>FF<sup>N</sup>RR<sup>W</sup>NC<sup>S</sup>TLD<sup>S</sup>LPVFGK<sup>V</sup>VT<sup>Q</sup>  
 rat ----LIQRQVQMC<sup>R</sup>KRNLEVMD<sup>S</sup>VR<sup>R</sup>HGA<sup>L</sup>AI<sup>E</sup>EC<sup>Q</sup>Y<sup>Q</sup>FF<sup>N</sup>RR<sup>W</sup>NC<sup>S</sup>TLD<sup>S</sup>LPVFGK<sup>V</sup>VT<sup>Q</sup>  
 mouse ----LIQRQVQMC<sup>R</sup>KRNLEVMD<sup>S</sup>VR<sup>R</sup>GQA<sup>L</sup>AI<sup>E</sup>EC<sup>Q</sup>Y<sup>Q</sup>FF<sup>N</sup>RR<sup>W</sup>NC<sup>S</sup>TLD<sup>S</sup>LPVFGK<sup>V</sup>VT<sup>Q</sup>  
 zebra fish ----LIQRQVQIC<sup>R</sup>KRNVE<sup>V</sup>MD<sup>A</sup>VR<sup>R</sup>GQA<sup>L</sup>AI<sup>D</sup>EC<sup>Q</sup>Y<sup>Q</sup>FF<sup>N</sup>RR<sup>W</sup>NC<sup>S</sup>TLES<sup>V</sup>PVFGK<sup>V</sup>VT<sup>Q</sup>  
 drosophila RYMPATRRQNHQ<sup>C</sup>RK<sup>E</sup>TGL<sup>P</sup>GL<sup>T</sup>SEARR<sup>L</sup>AT<sup>T</sup>HCEE<sup>Q</sup>FF<sup>Y</sup>D<sup>R</sup>W<sup>N</sup>CS<sup>I</sup>ETRG--KRNI<sup>F</sup>KK

**Figure 1.** (A) Family tree and DNA sequence chromatograms obtained by direct sequencing of PCR products showing the presence of the heterozygote C to T substitution in exon 2, not present in normal individuals (control, representative example out of 100, 200 alleles). (B) General structure of the *WNT4* gene and protein and location of the R83C mutation. The genomic organization is derived from the published sequences (Accession number NT\_004610). The protein domains were identified using the ELM server. (C) Sequence alignment of human, rat, mouse, zebrafish and drosophila *WNT4* proteins, showing the conserved R83 mutated in our patient. Alignments were performed using the CLUSTALW algorithm. nd, not done; WT, wild type.

eyebrows and synophrys, short philtrum, high palate, prominent ears, short neck, brachidactyly, cubitus valgus and broad chest). Signs of androgen excess included acne on the forehead and on the chest and mild facial hirsutism. The clitoral size was normal, but the vaginal introitus was small and short (0.7 cm). Her total testosterone was repeatedly elevated (up to 6.86 nmol/l, normal range 0.3–3.4). An extensive hormonal work-up showed normal levels of androstenedione (8.53 nmol/l, normal range 1.4–8.9), dehydroepiandrosterone sulphate (5  $\mu$ mol/l, normal range 2.2–9), luteinizing hormone (5.3 IU/l, normal range 4.5–25), FSH (4.5 IU/l, normal range 4–20), 17-hydroxyprogesterone (7.2 nmol/l, normal range 0.5–9.5), progesterone (1.92 nmol/l, normal range 1–64) and estradiol (216 pmol/l, normal range 76–1285).

Chromosomal analysis of 20 cells showed normal female 46,XX karyotype, and SRY was absent in lymphocytes.

Pelvic ultrasonography showed uterine agenesis, normal-sized gonads (20  $\times$  20 mm) but with anomalous location and a pattern of solid tissue on the left gonad that failed to show any follicular structure also on magnetic resonance imaging. The kidneys were normal in size (left 114  $\times$  50 mm; right 112  $\times$  40 mm) and location. This clinical picture has important similarity to that of our previously described patient (Biason-Lauber *et al.*, 2004).

#### Genomic DNA mutational analysis and expression studies

After obtaining informed consent, genomic DNA was extracted, amplified and sequenced as previously described (Biason-Lauber *et al.*, 2004) from peripheral blood leukocytes of the patients, of the family members (when available) as well as of 100 normal ethnically matched controls (200 alleles; male : female = 1:1). To study the functional implications of the mutation, we expressed wild-type (WT) and mutant WNT cDNA in human ovarian adenocarcinoma NIH:OVCAR3 (ATCC HTB-161) and analysed the influence of WNT4 variants on steroidogenic enzyme expression and activity as previously published (Biason-Lauber *et al.*, 2004).

#### Immunofluorescence

To distinguish wild-type and mutant WNT4, the wild-type protein was myc-tagged, whereas the mutant protein was Xpress-tagged. OVCAR3 cells were grown on glass coverslips and transfected with the wild-type (myc-tagged) or mutant (Xpress-tagged) WNT4 cDNA. Forty-eight hours after transfection, the cells were fixed for 10 min in methanol at  $-20^{\circ}\text{C}$  and blocked for unspecific binding in PBS containing 0.5% milk powder for 30 min at room temperature. The cells were incubated with an antibody against the myc epitope (9E10, dilution 1:100) or with anti-Xpress for 60 min at room temperature followed by an anti-mouse Cy3- and FITC-conjugated secondary antibody (Jackson Immuno Research, dilution 1:200) for 60 min. Nuclei were stained in a 1:10 000 dilution of Hoechst stock solution. Coverslips were mounted on glass plates, embedded in Kaiser's glycerol gelatin for microscopy (Merck) and examined using a Zeiss Axioskop microscope.

*In vivo* labelling of WNT4 with tritiated palmitate was performed as described previously (Willert *et al.*, 2003), and the assay was performed in cell extract after immunoprecipitation of the transfected WNT4 using anti-Xpress antibodies (Biason-Lauber *et al.*, 2004). The amounts of  $\beta$ -catenin in cell lysates were quantified using the Human Total  $\beta$ -catenin DuoSet IC ELISA (R&D Systems) as suggested by the provider. The already described E226G mutation (Biason-Lauber *et al.*, 2004) was used as internal control in all assays.

The study conformed to the guidelines of the institutional review board.

## Results and discussion

The WNT4 gene of the patient carried a heterozygote single-base exchange (C to T) in exon 2 of the WNT4 gene corresponding to an Arg83Cys (R83C) mutation in the WNT4 protein (Figure 1A,B). The absence of the mutation in the DNA of the mother, the siblings and 100 normal controls (Figure 1A) indicates that this substitution was either inherited from the father (whose DNA was not available) or a *de novo* event and that it is not a common polymorphism. The WNT4 genes of the other five patients did not carry any mutation in the coding region or in intron/exon boundaries. None of the six subjects had mutations in the TCF2 gene, which encodes the transcription factor HNF1 $\beta$ , crucial for Müllerian ducts, kidney and pancreas development (Lindner *et al.*, 1999).

The mutated Arg 83 is conserved among Wnt4 members (Figure 1C). Because WNT4 is known to repress male-specific genes, including the steroidogenic enzymes CYP17A1 and HSB3B2 (essential for the synthesis of testosterone) (Vainio *et al.*, 1999), it is to be expected that an inactive WNT4 would fail to do so. As a consequence, expression and activity of these enzymes would be higher with increased androgen synthesis. Accordingly, functional studies showed that the mutated WNT4 does not suppress the expression of the androgen-synthetic enzymes CYP17A1 and HSD3B2 in human ovarian cells, indicating again a loss-of-function mutation (Figure 2A,B). The 'escape' of the expression of steroidogenic enzymes from WNT4 control results in an increase of testosterone production in OVCAR3 cells transfected with the mutated WNT4 (Figure 2C), as it appears to be the case in the ovaries of our patient. The fact that transfection of WT WNT4 does not significantly change message and activity of the steroidogenic enzymes indicates that, in basal conditions, overexpression of normal WNT4 does not override the effect of the endogenous WNT4 in this system and indicates a possible limitation of this *in vitro* assay. The mutated WNT4 has dominant negative properties, providing a clear genotype–phenotype correlation.

According to the most accepted view, WNT-secreted proteins bind to the Frizzled family of receptors and start at least three different intracellular pathways, resulting in the regulation of gene expression and/or changes in cell behaviour. The canonical pathway involves a co-receptor from the low-density lipoprotein receptor family and results in stabilization of intracellular  $\beta$ -catenin.  $\beta$ -Catenin is a multifunctional protein that can act as a transcriptional regulator upon entering the nucleus. However, it is rapidly degraded by ubiquitination after phosphorylation by a complex consisting of APC and axin, which facilitate the phosphorylation of  $\beta$ -catenin by casein kinase 1 and then glycogen synthase kinase 3. Binding of WNT proteins to the surface receptor(s) leads to activation of the protein that when dishevelled in turn inactivates the destruction complex, allowing  $\beta$ -catenin to accumulate in the cytoplasm and enter the nucleus. In the absence of WNT4 binding, the stabilization of  $\beta$ -catenin will not take place, resulting in the alteration of target gene expression (Hsieh, 2004).

The mutant WNT4 of our patient could not be secreted (Figure 3A), although it was normally produced (Figure 3A) and lipid-modified (Figure 3B). Although staining for the

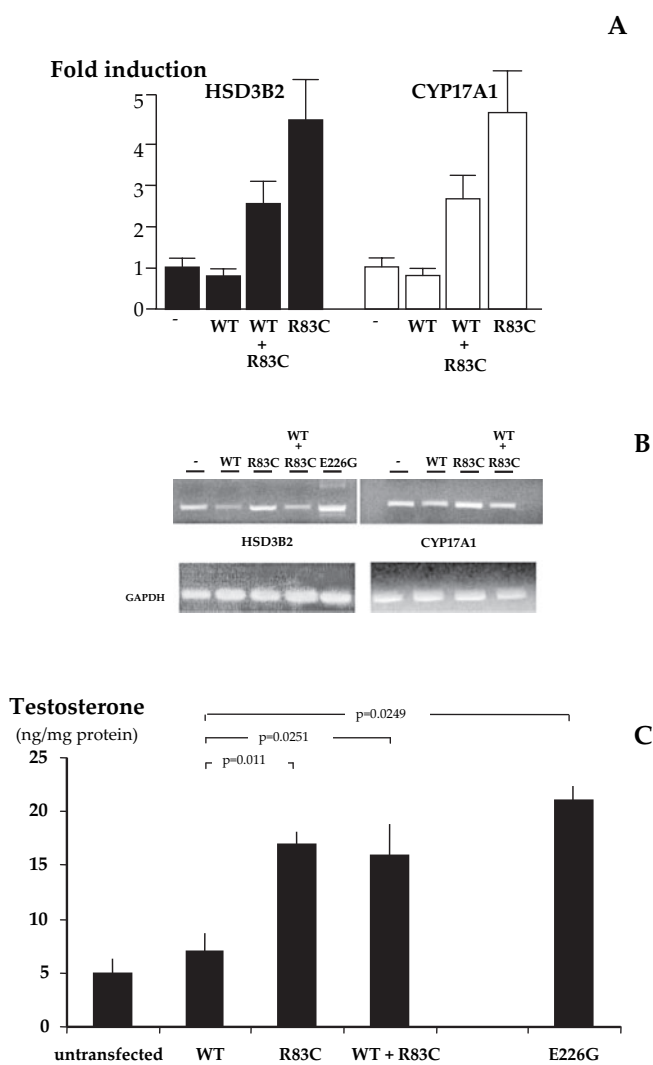

**Figure 2.** The R83C-mutated WNT4 is unable to suppress the expression and activity of steroidogenic enzymes in the ovarian adenocarcinoma cell line (OVCAR3). (A) Quantification by RT-PCR of the expression of the steroidogenic enzymes  $17\alpha$ -hydroxylase (CYP17A1) and  $3\beta$ -hydroxysteroid dehydrogenase 2 (HSD3B2) in the absence (-) or presence of transfection of normal (WT), mutant (R83C) WNT4 cDNA and 1:1 combination of the two. Results are expressed as relative increase in transfected cells as compared with untransfected cells. Panel B shows the results of the qualitative reverse-transcriptase PCR experiments. Glyceraldehyde-3-phosphatedehydrogenase (GAPDH), a protein expressed in most tissues, was used as internal control. (C) Testosterone levels in cell culture medium from OVCAR3 cells untransfected or transfected with R83C mutant, wild type (WT), a combination of the two (R83C + WT), and E226G mutant WNT4 as reference are shown. The results are means  $\pm$  SD derived from three independent experiments. *P*-values were calculated using the paired *t*-test. Non-significant *P*-values are not indicated.

wild-type protein can be detected inside and outside transfected OVCAR3 cells (Figure 4A), the mutated WNT4 was detectable only in the cytoplasm of transfected cells (Figure 4B) and appears to block the wild type from exiting the cells (Figure 4C), thus preventing any activation of the receptors and therefore impairing the WNT4-dependent signal.

The demonstration that the mutation causes indeed a defect in the WNT4 signal transduction pathway is given by the detection of very low amounts of  $\beta$ -catenin (stabilized by the activation of

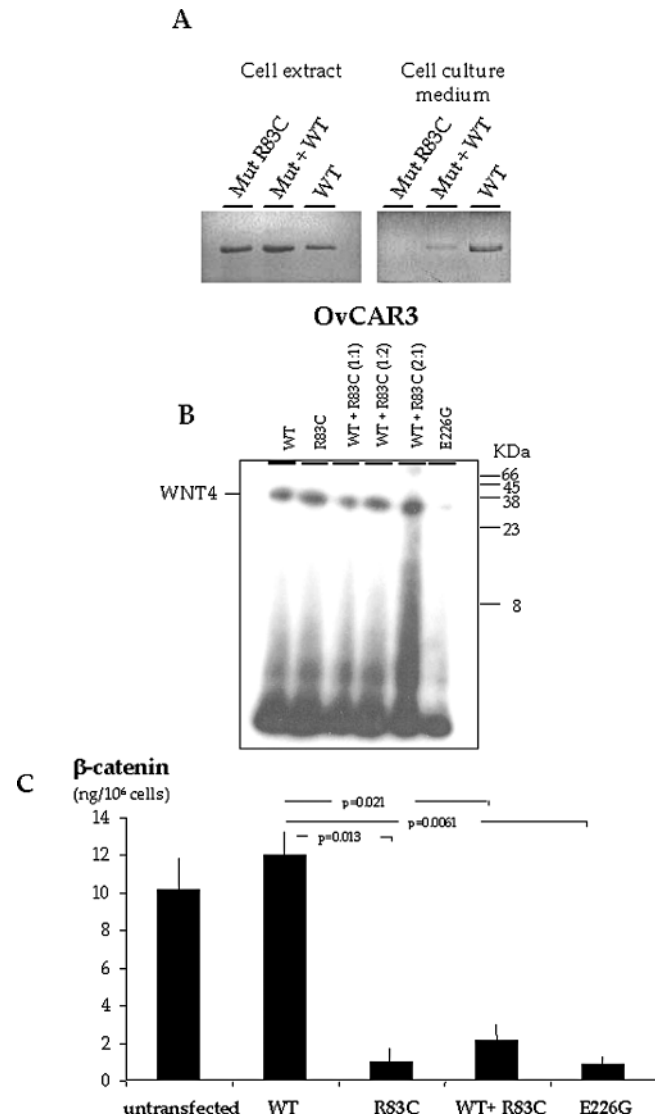

**Figure 3.** (A) Western blot analysis of WNT4 from the cell culture medium and the cell extract of OVCAR3 cells after transfection with R83C mutant, wild-type (WT) WNT4 cDNA or an equimolar ratio of the two, using the anti Xpress antibody recognizing only the transfected human WNT4. The mutated protein is not secreted, but the loss-of-function is not because of decreased protein amount or stability. (B) The mutated R83C WNT4 protein appears to be normally lipid-modified. *In vivo* labelling of WNT4 with tritiated palmitate is shown. WNT4 was partially purified from cell extracts of OVCAR3 cells transfected with R83C mutant, wild type (WT), a combination of the two (R83C + WT), and E226G mutant WNT4 as reference, then treated with <sup>3</sup>H palmitate for 5 h and immunoprecipitated. (C) The WNT signalling pathway is impaired in cells expressing the mutated WNT4. Amounts of  $\beta$ -catenin from OVCAR3 cells untransfected or transfected with WNT4 variants as described in A are depicted. The decreased amounts of measurable  $\beta$ -catenin in cell transfected with the mutant WNT4 alone or in combination with an equimolar amount of wild-type protein suggest that the signalling pathway is weakened and that the mutant WNT4 has dominant negative properties.

Wnt pathway) in OVCAR3 cells transfected with the mutant WNT4 (Figure 3C). Although the attachment of lipid to the mutated WNT4 seems to be normal, a substitution of an arginine for a cysteine will probably lead to misfolded protein, because one extra cysteine may promote the formation of illegitimate

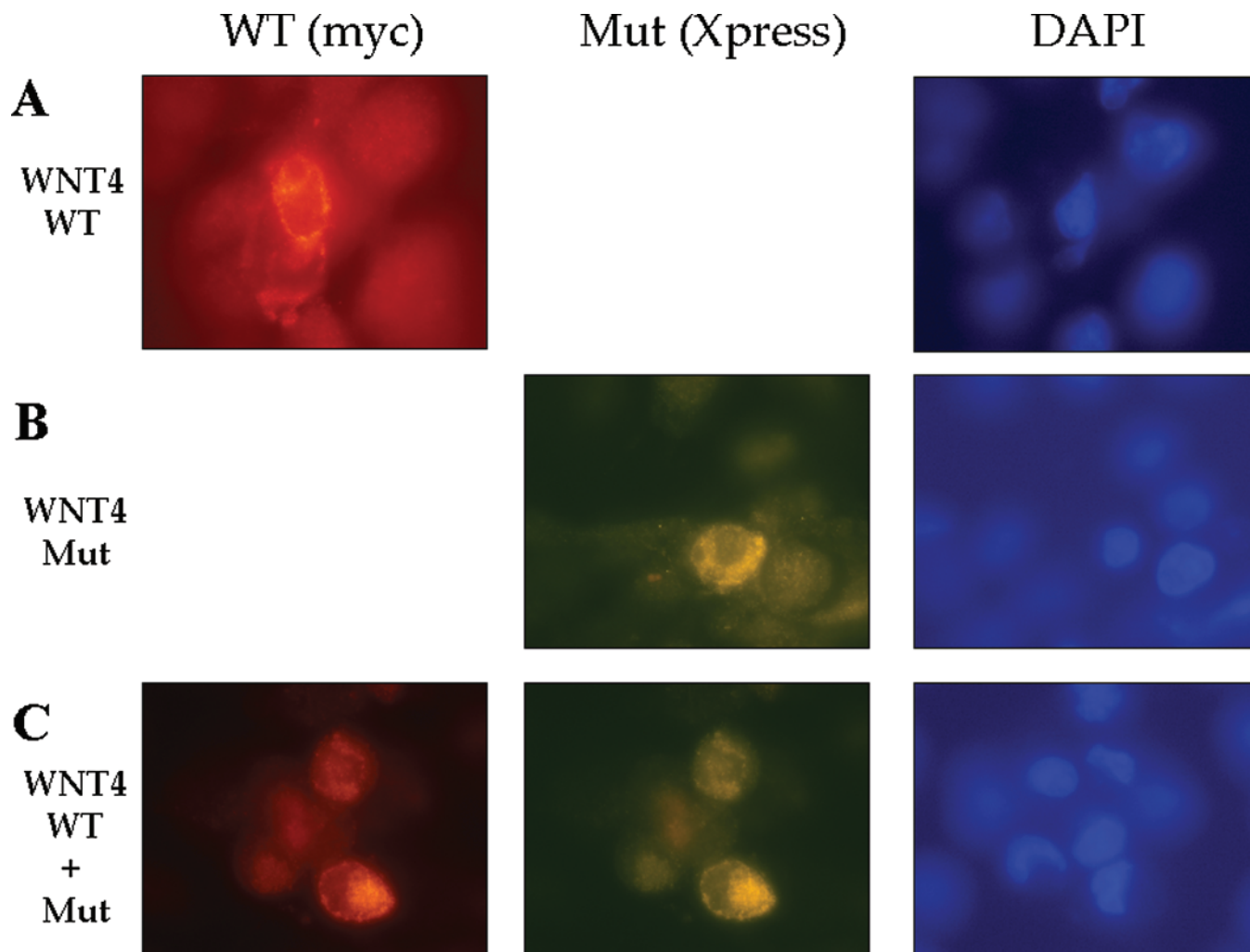

**Figure 4.** Immunofluorescent staining of OVCAR3 cells overexpressing (A) myc-tagged wild-type (WT) WNT4, (B) Xpress-tagged mutant (Mut) protein or (C) an equimolar amount of the two. DAPI: nuclear staining. Whereas the WT WNT4 can be detected in the cytoplasm and the extracellular space, specific staining for the mutated protein showed intracellular positivity only. When the two variants were combined, only intracellular staining for both protein species was seen.

disulphide bonds and misfolding. Misfolded proteins are usually retained in the endoplasmic reticulum (ER), cannot be secreted and do not activate their signalling pathway. Misfolded proteins can be targeted to the degradation pathway but can also escape this protective mechanism and form intractable aggregates. The importance of such phenomenon is demonstrated by the increasing number of pathologies associated with the deposition of such aggregates in tissues (Dobson, 2004). In this view, a possible explanation of the lack of secretion of the wild-type WNT4 protein in the presence of its mutant counterpart might be the 'trapping' of the wild-type protein in such deposits, although a seeding (analogue to prion proteins, Jarrett and Lansbury, 1993; Prusiner, 1997) or cross-seeding (analogue to amyloid  $\beta$ -protein, Lundmark *et al.*, 2005; Yamamoto *et al.*, 2005) cannot not be excluded.

This second loss-of-function mutation in *WNT4* gene causing developmental abnormalities in humans confirms the role of WNT4 as a major player in the development and maintenance of the female phenotype in women. This study can also help refine the phenotype of WNT4 deficiency in humans. In fact, it seems that, at least in this limited casuistic group of patients, the absence

of uterus (and not other Müllerian abnormalities) and the androgen excess are the pathognomonic signs of WNT4 defects, suggesting that WNT4 deficiency might be a clinical entity distinct from the typical Mayer-Rokitansky-Kuster-Hausler syndrome, also in view of recent work excluding WNT4 mutations in the classical form of the syndrome (Clement-Ziza *et al.*, 2005).

#### Acknowledgements

We thank Roel Nusse for his comments on the functional implications of misfolding. We are also grateful to Claus Heizmann for his continuous support. This work was supported by a Research Grant of the University of Zurich (54181801).

#### References

- Biason-Lauber A, Konrad D, Navratil F and Schoenle EJ (2004) A WNT4 mutation associated with Mullerian-duct regression and virilization in a 46,XX woman. *N Engl J Med* 351,792–798.
- Birk OS, Casiano DE, Wassif CA, Cogliati T, Zhao L, Zhao Y, Grinberg A, Huang S, Kreidberg JA, Parker KL *et al.* (2000) The LIM homeobox gene *Lhx9* is essential for mouse gonad formation. *Nature* 403,909–913.

- Clement-Ziza M, Khen N, Gonzales J, Cretolle-Vastel C, Picard JY, Tullio-Pelet A, Besmond C, Munnich A, Lyonnet S and Nihoul-Fekete C (2005) Exclusion of WNT4 as a major gene in Rokitsansky-Kuster-Hauser anomaly. *Am J Med Genet A* 137,98–99.
- Dobson CM (2004) Principle of protein folding, misfolding and aggregation. *Semin Cell Dev Biol* 15,3–16.
- Hammes A, Guo JK, Lutsch G, Leheste JR, Landrock D, Ziegler U, Gubler MC and Schedl A (2001) Two splice variants of the Wilms' tumor 1 gene have distinct functions during sex determination and nephron formation. *Cell* 106,319–329.
- Hsieh J-C (2004) Specificity of WNT–receptor interactions. *Front Biosci* 9,1333–1338.
- Jarrett JT and Lansbury PTJ (1993) Seeding 'one dimensional crystallization' of amyloid: a pathogenic mechanism in Alzheimer's disease and scrapie? *Cell* 73,1055–1058.
- Jeays-Ward K, Dandonneau M and Swain A (2004) Wnt4 is required for proper male as well as female sexual development. *Dev Biol* 276,431–440.
- Jeays-Ward K, Hoyle C, Brennan J, Dandonneau M, Alldus G, Capel B and Swain A (2003) Endothelial and steroidogenic cell migration are regulated by WNT4 in the developing mammalian gonad. *Development* 130,3663–3670.
- Jordan BK, Mohammed M, Ching ST, Delot E, Chen XN, Dewing P, Swain A, Rao PN, Elejalde BR and Vilain E (2001) Up-regulation of WNT-4 signaling and dosage-sensitive sex reversal in humans. *Am J Hum Genet* 68,1102–1109.
- Katoh-Fukui Y, Tsuchiya R, Shiroishi T, Nakahara Y, Hashimoto N, Noguchi K and Higashinakagawa T (1998) Male-to-female sex reversal in M33 mutant mice. *Nature* 393,688–692.
- Lindner TH, Njolstad PR, Horikawa Y, Bostad L, Bell GI and Sovik O (1999) A novel syndrome of diabetes mellitus, renal dysfunction and genital malformation associated with a partial deletion of the pseudo-POU domain of hepatocyte nuclear factor-1beta. *Hum Mol Genet* 8,2001–2008.
- Lundmark K, Westermark T, Olsen A and Westermark P (2005) Protein fibrils in nature can enhance amyloid protein A amyloidosis in mice: cross-seeding as a disease mechanism. *Proc Natl Acad Sci USA* 102,6098–6102.
- Luo X, Ikeda Y and Parker KL (1994) A cell-specific nuclear receptor is essential for adrenal and gonadal development and sexual differentiation. *Cell* 77,481–490.
- MacLaughlin DT and Donahoe PK (2004) Sex determination and differentiation. *N Engl J Med* 350,367–378.
- Miyamoto N, Yoshida M, Kuratani S, Matsuo I and Aizawa S (1997) Defects of urogenital development in mice lacking Emx2. *Development* 124,1653–1664.
- Prusiner SB (1997) Prion disease and the BSE crisis. *Science* 278,245–251.
- Vainio S, Heikkila M, Kispert A, Chin N and McMahon AP (1999) Female development in mammals is regulated by Wnt-4 signalling. *Nature* 397,405–409.
- Willert K, Brown JD, Danenberg E, Duncan AW, Weissman IL, Reya T, Yates JR III and Nusse R (2003) Wnt proteins are lipid-modified and can act as stem cell growth factors. *Nature* 423,448–452.
- Yamamoto N, Matsuzaki K and Yanagisawa K (2005) Cross-seeding of wild-type and hereditary variant-type amyloid b-proteins in the presence of gangliosides. *J Neurochem* 95,1167–1176.
- Yao HH, Matzuk MM, Jorgez CJ, Menke DB, Page DC, Swain A and Capel B (2004) Follistatin operates downstream of Wnt4 in mammalian ovary organogenesis. *Dev Dyn* 230,210–215.

*Submitted on January 27, 2006; resubmitted on March 21, 2006, May 16, 2006 and June 6, 2006; accepted on July 5, 2006*