

Sex-Chromosome Homomorphy in Palearctic Tree Frogs Results from Both Turnovers and X–Y Recombination

Christophe Dufresnes,^{*1} Amaël Borzée,² Agnès Horn,¹ Matthias Stöck,³ Massimo Ostini,¹ Roberto Sermier,¹ Jérôme Wassef,¹ Spartak N. Litvinchuck,⁴ Tiffany A. Kosch,² Bruce Waldman,² Yikweon Jang,⁵ Alan Brelsford,¹ and Nicolas Perrin¹

¹Department of Ecology & Evolution, Biophore Building, University of Lausanne, Lausanne, Switzerland

²Laboratory of Behavioral and Population Ecology, School of Biological Sciences, Seoul National University, Seoul, Republic of Korea

³Leibniz-Institute of Freshwater Ecology and Inland Fisheries—IGB, Berlin, Germany

⁴Institute of Cytology, Russian Academy of Sciences, St. Petersburg, Russia

⁵Department of Life Sciences and Division of EcoScience, Ewha Womans University, Seoul, Republic of Korea

***Corresponding author:** E-mail: christophe.dufresnes@unil.ch.

Associate editor: Patricia Wittkopp

Abstract

Contrasting with birds and mammals, poikilothermic vertebrates often have homomorphic sex chromosomes, possibly resulting from high rates of sex-chromosome turnovers and/or occasional X–Y recombination. Strong support for the latter mechanism was provided by four species of European tree frogs, which inherited from a common ancestor (~5 Ma) the same pair of homomorphic sex chromosomes (linkage group 1, LG1), harboring the candidate sex-determining gene *Dmrt1*. Here, we test sex linkage of LG1 across six additional species of the Eurasian *Hyla* radiation with divergence times ranging from 6 to 40 Ma. LG1 turns out to be sex linked in six of nine resolved cases. Mapping the patterns of sex linkage to the *Hyla* phylogeny reveals several transitions in sex-determination systems within the last 10 My, including one switch in heterogamety. Phylogenetic trees of DNA sequences along LG1 are consistent with occasional X–Y recombination in all species where LG1 is sex linked. These patterns argue against one of the main potential causes for turnovers, namely the accumulation of deleterious mutations on nonrecombining chromosomes. Sibship analyses show that LG1 recombination is strongly reduced in males from most species investigated, including some in which it is autosomal. Intrinsically low male recombination might facilitate the evolution of male heterogamety, and the presence of important genes from the sex-determination cascade might predispose LG1 to become a sex chromosome.

Key words: *Hyla*, recombination, *DMRT1*, sex-chromosome transitions, fountain of youth hypothesis

Introduction

Sex chromosomes are evolving along drastically different trajectories, depending on lineages. Most mammals and birds, for instance, present strongly heteromorphic sex chromosomes with highly degenerated Y and W chromosomes, respectively. This heteromorphy results from a long history of recombination arrest, initiated some 170 and 130 Ma, respectively (Charlesworth D and Charlesworth B 2000; Bachtrog 2013). In sharp contrast, many groups of fish, amphibians and reptiles present undifferentiated sex chromosomes, testifying to a very distinct history (Bachtrog et al. 2014).

Homomorphy may result from a high rate of turnovers, during which sex chromosomes are replaced before they had time to decay (Schartl 2004; Volff et al. 2007). Sex-determination mechanisms seem particularly labile in amphibians and fishes; comparative mapping shows that sex-determining systems can switch rapidly (Kikuchi and Hamaguchi 2013; Malcom et al. 2014), leading to different sex chromosome pairs between closely related species (Mank and Avise 2009; Kitano and Peichel 2011) or even conspecific populations (Miura 2007). Different forces may drive turnovers, including sexually antagonistic selection (van Doorn and Kirkpatrick

2007, 2010), sex-ratio selection (Grossen et al. 2011), and deleterious mutations accumulating on nonrecombining chromosomes (Blaser et al. 2013). Despite substantial theoretical consideration, the relative contribution of these mechanisms in natural systems remains poorly understood. Comparative analyses suggest that, in this context of high turnover, some genomic regions are repeatedly and independently co-opted for sex determination, likely because they carry important genes from the sex-determining cascade (Graves and Peichel 2010; O'Meally et al. 2012; Brelsford et al. 2013).

Alternatively, homomorphy may result from occasional X–Y recombination, occurring either in males or in sex-reversed XY females (the “fountain-of-youth” model; Perrin 2009). Theoretical studies suggest that X–Y recombination should evolve toward very low but nonzero values, under the opposing forces of sexually antagonistic selection (which favors recombination arrest) and the load of deleterious mutations that accumulate on nonrecombining regions (Grossen et al. 2012). Very low recombination rates seem sufficient to purge this load and prevent X–Y differentiation over evolutionary times (Grossen et al. 2012). This latter model has received support from studies on a group of European tree frog

species, namely *Hyla arborea*, *H. intermedia*, *H. molleri*, and *H. orientalis* (hereafter referred to as the *H. arborea* clade). All four species share the same pair of sex chromosomes with male heterogamety, inherited from a common ancestor approximately 5 Ma, and maintained homomorphic by occasional X–Y recombination (Stöck et al. 2011; Guerrero et al. 2012; Stöck, Savary, Zaborowska, et al. 2013). This linkage group 1 (LG1) has been independently co-opted for sex in other deeply diverged groups of amphibians from the Bufonid and Ranid radiations (Brelsford et al. 2013), and contains two important genes from the sex-determining cascade (*Dmrt1* and *Amh*) known to have seized the master sex-determination role in several groups of vertebrates, such as birds (Smith et al. 2009) and monotremes (Cortez et al. 2014). The N-terminal part of *Dmrt1*, which encodes the DM domain, carries a trans-specific polymorphism that perfectly associates with sex in all four species from the *H. arborea* clade (Brelsford, Dufresnes, and Perrin, unpublished), suggesting a unique origin for sex determination, and that occasional X–Y recombination is the only mechanism preventing sex chromosome differentiation in this clade.

The question arises whether the same mechanism actually accounts for sex chromosome homomorphy throughout the whole Eurasian *Hyla* radiation, or whether sex-chromosome turnovers also played a role. Importantly, if sex chromosomes recombine occasionally, then turnovers cannot result from the accumulation of deleterious mutations. To empirically test the relative contribution and timeframes of these mechanisms, we extended the survey to six additional species from the European tree-frog radiation with deeper divergence times from *H. arborea* (Stöck et al. 2012), namely *H. sarda* (~6 My), *H. savignyi*, *H. felixarabica* (~7.5) and *H. meridionalis* (~10 My), as well as their East Asian relatives *H. japonica* and *H. suweonensis* with divergence times 30–40 Ma (Smith et al. 2005). Phylogenetic relationships based on mtDNA markers are shown in figure 1. Using a series of cross-amplifying markers, 1) we genotyped sexed adults and their offspring to test for a sex-determining role of LG1, 2) we established LG1 linkage maps to quantify sex differences in recombination rates, and 3) we performed phylogenetic analyses of LG1 sequences to identify signatures of recurrent X–Y recombination. In addition, we developed and analyzed genotyping-by-sequencing (GBS) libraries for species of the European radiation, in order to test support for the mtDNA phylogeny (fig. 1) or for alternative relationships.

Results

Sex Linkage of LG1

In *H. meridionalis*, LG1 displayed clear patterns of sex linkage and male heterogamety: All 20 females were homozygous for allele 209 at locus *Ha-T45*, whereas all 20 males were heterozygous 209/212, suggesting these two alleles to be fixed on X and Y chromosomes, respectively (supplementary file S1, Supplementary Material online). Similarly, all males displayed one copy of allele 330 at locus *Ha-T11* (suggesting this allele to be fixed on the Y), whereas alleles 330, 333 and 336 segregated

on the X. Accordingly, F_{ST} between sexes was significantly positive (table 1).

In *H. suweonensis*, the only marker that could be amplified (*Ha-5-22*, situated within the gene *Med15*) indicated sex linkage and female heterogamety; alleles 228 and 231 were present in both sexes, but most females also presented one copy of allele 234, not found in any male. This suggests a standing polymorphism on the W chromosome, with one allele (234) specific to the W chromosome, and another one (228) shared with the Z chromosome. The associated *P* value (probability that the observed pattern occurs by chance in absence of sex linkage) is approximately 0.0001 when considering all 30 individuals (23 males, 7 females; supplementary file S1, Supplementary Material online), and approximately 0.016 when limiting analysis to the 12 individuals from Siheung (5 males, 7 females). Consequently, in this population male–female F_{ST} was significantly positive (table 1).

In contrast, LG1 was not sex linked in *H. sarda*, *H. savignyi*, and *H. japonica*: Sibship analyses showed no correlation between the phenotypic sex of offspring and paternal or maternal haplotypes (supplementary file S1, Supplementary Material online). Accordingly, F_{ST} between sexes did not significantly differ from zero. Regarding *H. felixarabica*, genotypes and allele frequencies provided no support for sex

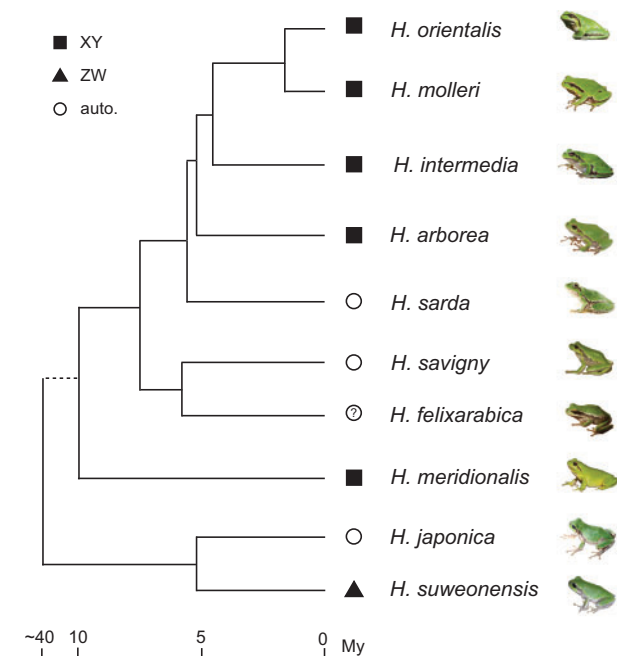

FIG. 1. LG1 tree of sex in Palearctic tree frog lineages. Tree topology and approximate divergence times (My) were adapted from mitochondrial phylogenies and molecular dating by Smith et al. (2005) and Stöck et al. (2012). *Hyla suweonensis* unambiguously branched as a sister taxon of *H. japonica*. Mitochondrial relationships in European species are well-supported by GBS data except for *H. sarda* which seems polytomous to *H. savignyi*, and the relative position of *H. intermedia* with *H. arborea* (supplementary file S3, Supplementary Material online). Symbols show patterns of sex-linkage for *H. arborea*'s linkage group LG1 (auto.: autosomal). Uncertainty remains for *H. felixarabica* since only adult males were analyzed.

linkage (supplementary file S1, Supplementary Material online), although we could only investigate male heterogamety (having only males in our sample). None of the other markers and linkage groups tested in these four species showed any evidence for sex linkage (supplementary file S1, Supplementary Material online). Altogether, LG1 was thus confirmed or suggested to be sex linked in two additional species (in total: five XY one ZW) and autosomal in three (fig. 1 and table 2).

Sex-Specific Recombination Rates

As previously documented from the *H. arborea* clade (Stöck et al. 2011; Stöck, Savary, Zaborowska, et al. 2013), LG1 recombination rate was much lower in males than in females in three newly tested taxa (fig. 2). Interestingly, this included two species (*H. sarda* and *H. savignyi*) where LG1, despite being autosomal, displayed about 30-fold less recombination in males. It is worth noting that, in *H. arborea*, male recombination is strongly reduced over the whole genome (Berset-Brändli et al. 2008; Dufresnes, Brelsford, and Perrin 2014). *Hyla japonica*, in contrast, where LG1 is also autosomal, displayed the same average recombination rate between males and females. However, unlike in European taxa, closer inspection of the family data suggests strong individual variation: In both sexes some individuals show almost complete absence of crossovers, whereas others display large recombination over all markers (supplementary file S2, Supplementary Material online).

LG1-Sequences Phylogenies

LG1 sequences allowed perfect discrimination between all the lineages considered, except for the youngest sister taxa *H. molleri* and *H. orientalis*, which showed incomplete lineage sorting for *Med15* and *Ha-A103* (fig. 3). It also appears from these sequences that the position of *H. sarda* is not clearly settled, in line with a polytomy with *H. savignyi* (see below). In all species where LG1 was sex linked, male and female alleles

always clustered by species, consistent with occasional X–Y or Z–W recombination (fig. 3).

Phylogenetic Inference and Hypothesis Testing Based on GBS Data

We obtained an average of 2.7 M reads per sample, with samples ranging from 1.6 M to 5.6 M reads. Mean sequence depth was 13.1 for the 2,906 single nucleotide polymorphisms (SNPs) genotyped in all species, and 4.7 for the 80,118 SNPs genotyped in at least three species.

Bayesian phylogenetic inference was overall very concordant with mtDNA, and only the placement of *H. sarda* relative to *H. savignyi* remained unresolved, resulting in a polytomous topology (supplementary file S3, Supplementary Material online). As shown by Stöck et al. (2012), the branching of *H. sarda* in the mtDNA phylogeny is not significantly supported either.

We found no significant difference in support for the three possible positions of *H. sarda* (Shimodaira–Hasegawa [S-H] test; $P > 0.54$ in all comparisons). The same results were obtained for the 2,906 SNPs genotyped in all species and the 80,118 SNPs genotyped in at least three species. Hence, nuclear data do not oppose the mtDNA phylogeny (namely the *H. savignyi* clade being sister to a *H. sarda/arborea* clade), but we cannot reject either the two alternative scenarios where *H. savignyi* is sister to either the *H. sarda* or the *H. arborea* clade. Given the strong statistical power of our data sets, this possibly signals a true polytomy, with multiple simultaneous speciation events triggered by the same geological event, for example, the end of the Messinian salinity crisis (5–6 Ma; Stöck et al. 2012).

Discussion

Although previous work was limited to the young *H. arborea* clade, where LG1 is conserved as the sex chromosomes (Stöck et al. 2011; Stöck, Savary, Zaborowska, et al. 2013), our analyses clearly establish that this linkage group is not universally sex linked in the Eurasian tree-frog complex. Our sibship analyses, combined with low male recombination, provided strong power to detect a male heterogametic system on LG1. In *H. sarda*, *H. savignyi*, and *H. japonica*, the maximal distance between two markers on the male map is 4.0, 4.7, and 20.6 cM, respectively. Assuming the SD locus to lie in the middle of this segment (the most conservative assumption), the two neighboring markers would be, respectively, 2.0, 2.4 and 10.3 cM apart from the SD locus, and thus should associate with sex in 90–98% of offspring, which cannot escape detection. We thus conclude that LG1 is not sex linked in these species, and therefore that sex-chromosome turnovers occurred in both the European and the East Asian radiations (fig. 1).

The European radiation shows at least one and more likely two transitions within the last 10 My, which may have occurred along different scenarios (fig. 4). According to scenario a), the ancestral LG1 sex chromosome independently became autosomal in the two lineages leading to *H. sarda* on one hand, and to *H. savignyi/H. felixarabica* on the other hand.

Table 1. Summary Statistics Used to Document Sex-Linkage of LG1.

Taxon	Sex-Specific Inheritance ^a	Sex-Specific Genotypes ^b	♀–♂ F_{ST}
<i>Hyla sarda</i>	NS	—	0.006 ^{NS}
<i>Hyla savignyi</i>	NS	—	0.0143 ^{NS}
<i>Hyla meridionalis</i>	—	2.97×10^{-13} *	0.1764 *
<i>Hyla japonica</i>	NS	—	0.0006 ^{NS} (Seocheon)
<i>Hyla suweonensis</i>	—	0.016 * (Siheung)	0.3242 * (Siheung)
		0.0001 * (Siheung + Geumchon)	

NOTE.—NS, nonsignificant.

* $P < 0.05$, highlighted in italics.

^aFisher's exact test of sex-specific allele inheritance in families (supplementary file S1, Supplementary Material online).

^bProbability of observed sex-specific adult genotypes to have occurred by chance, from combinatory statistics (supplementary file S1, Supplementary Material online).

Table 2. Sex-Linkage of *Hyla* Linkage Group LG1 in the Eurasian Tree Frogs Investigated.

Taxon	LG1 Sex-Linked?	Evidence	References
<i>Hyla arborea</i>	Yes, XY	Sex-specific alleles in populations Sex-specific inheritance of alleles	Berset-Brändli et al. (2006) Dufresnes, Brelford, and Perrin (2014)
<i>Hyla intermedia</i>	Yes, XY	Sex-specific alleles in populations	Stöck et al. (2011)
<i>Hyla molleri</i>	Yes, XY	Sex-specific alleles in populations	Stöck et al. (2011)
<i>Hyla orientalis</i>	Yes, XY	Sex-specific inheritance of alleles	Stöck, Savary, Zaborowska, et al. (2013)
<i>Hyla sarda</i>	No	Absence of sex-specific alleles in populations Random inheritance of alleles	This study This study
<i>Hyla savignyi</i>	No	Absence of sex-specific alleles in populations Random inheritance of alleles	This study This study
<i>Hyla felixarabica</i>	Prob. not as XY	Autosomal-like male genotypes in populations	This study
<i>Hyla meridionalis</i>	Yes, XY	Sex-specific alleles in populations	This study
<i>Hyla japonica</i> ^a	No	Absence of sex-specific alleles in populations Random inheritance of alleles	This study This study
<i>Hyla suweonensis</i> ^b	Yes, ZW	Sex-specific alleles in populations	This study

^aAn XY system was identified in this species (Kawamura and Nishioka 1977), although not on LG1.

^bA ZW system was previously suggested in this species from cytogenetics (Yu and Lee 1990).

In scenario b), the ancestral LG1 sex chromosome first became autosomal in the sister group to *H. meridionalis*, and then reverted to a sex chromosome in the common ancestor to the *H. arborea* clade. In scenario c), LG1 was autosomal in the common ancestor to all European species, and independently took a sex-determining role in the *H. meridionalis* and the *H. arborea* clades. Scenario d) depicts the only situation where a single turnover suffices to account for the patterns documented here: It assumes the *H. arborea* clade to be sister to a *H. sarda/savignyi* clade, with a single transition from an ancestrally sex-linked LG1 to an autosomal LG1 in the branch leading to the *H. sarda/savignyi* clade. The alternative topology where *H. sarda* diverged prior to *H. savignyi* implies the same scenarios as depicted in figure 4a–c, and thus the same number of transitions.

These several scenarios might be tested through further investigations on sex-determination systems in *Hyla*. Scenario (a) predicts sex-determination mechanisms to differ between *H. sarda* and *H. savignyi*; identifying the sex chromosomes of these two species would provide a first test. Scenarios (a) and (d) also predict the same sex-determination mechanism in the *H. meridionalis* and *H. arborea* clades, which does not seem to be supported: phylogenetic analyses of the candidate sex-determining gene *Dmrt1* are revealing a trans-species X–Y polymorphism at exon 1 that is shared by all species from the *H. arborea* clade, but not by *H. meridionalis* (Brelford, Dufresnes, and Perrin, unpublished), suggesting an independent event. Scenarios (b) and (c) might be tested by investigating species from the sister group to the European species (e.g., *H. chinensis* or *H. annectans*; Pyron and Wiens 2011); scenario (b) would receive support if these species also use LG1 as the sex chromosome, and scenario (c) if they share the same sex chromosome as *H. sarda* and *H. savignyi*.

The East Asian radiation also likely underwent at least one transition event, which further involved a switch in heterogamety. These two species seem to differ in their sex-chromosome pair (LG1 in *H. suweonensis* but not in

H. japonica). In addition, our genotypic data point to a ZW system in *H. suweonensis* (as otherwise also proposed based on cytogenetic analyses; Yu and Lee 1990), whereas its sister species *H. japonica* has been shown from sex-reversal experiments to present an XY system (Kawamura and Nishioka 1977).

Despite this context of rapid changes, the one chromosome pair LG1 (out of twelve in *Hyla*; Anderson 1991) was found to be the sex chromosome in six of nine resolved cases, both as an XY and a ZW system, and has thus been co-opted for sex determination several times independently within the Eurasian tree-frog radiation. More broadly, this genomic region also independently evolved a sex-determination role in several deeply divergent lineages of frogs (Brelford et al. 2013), as well as several species within the Ranidae (Miura 2007). The same sort of recurrence has been suggested for a few other genomic regions (Graves and Peichel 2010; O’Meally et al. 2012), and might result from the presence of important genes from the sex-determination cascade. In the present instance, a strong candidate is *Dmrt1*, a gene known to play a key role in sex differentiation across the whole animal kingdom (Beukeboom and Perrin 2014). *Dmrt1* or paralogs have seized the leading sex-determination role in a diversity of vertebrates, including birds, fish, and amphibians (Matson and Zarkower 2012). *Dmrt1* is a masculinizing gene, so that maleness might simply result from overexpression of the Y copy. In ZW systems conversely (such as suggested here for *H. suweonensis*), femaleness might result from a loss of function of the W gametolog, as documented, for example, in birds.

Other features may create self-reinforcing loops that further favor the recurrent co-option of specific genomic regions. First, chromosomes that already played a sex-determination role are expected to be enriched in genes with the potential to evolve sexually antagonistic effects, making them more likely to recapture a sex-determination function during future turnovers (Blaser et al. 2014). Second,

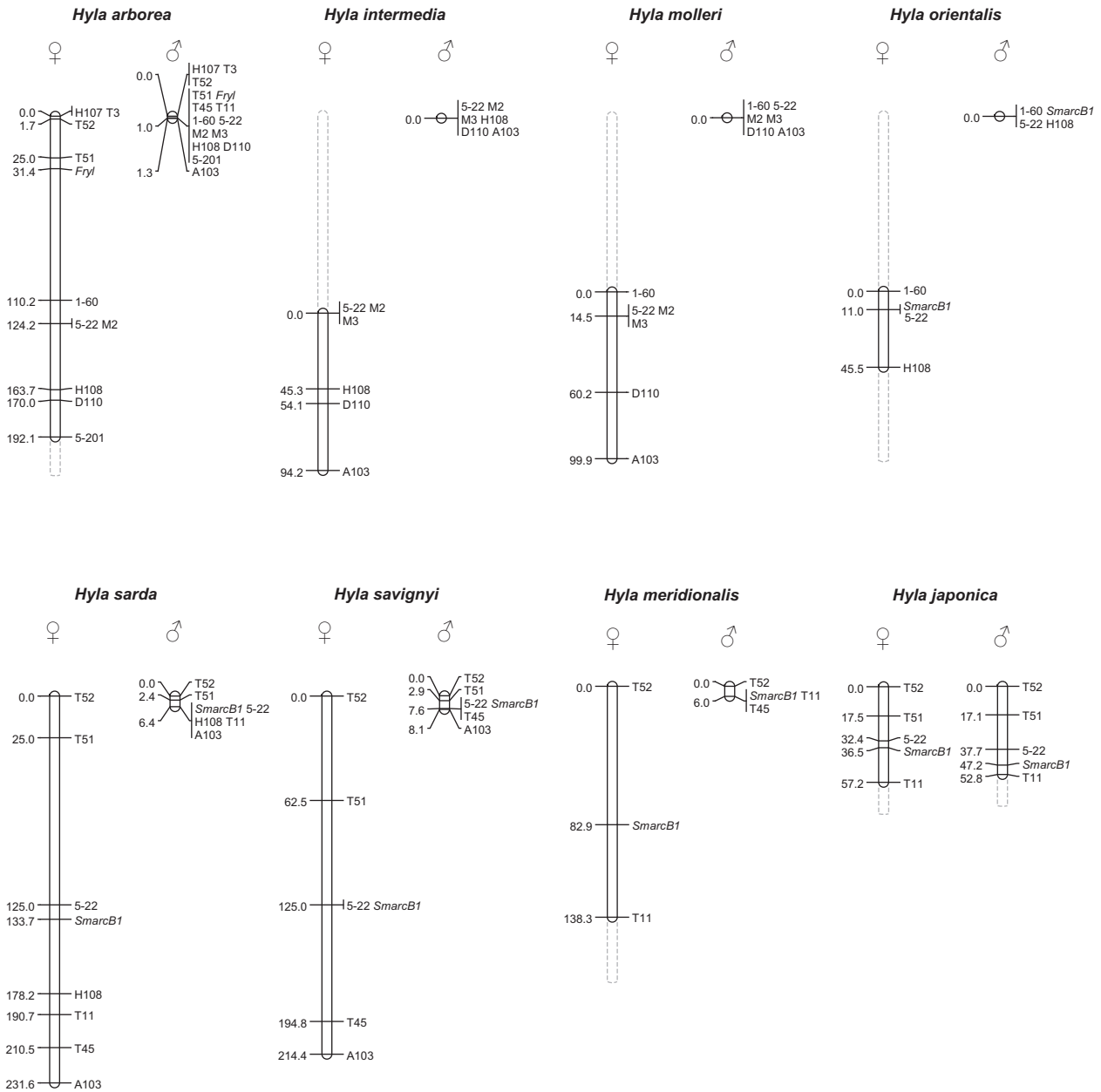

FIG. 2. Sex-specific linkage maps of linkage group LG1. Loci orders were calculated separately for each species, and are based on the highest likelihood (CRIMAP). The *Hyla arborea* map was adapted from Dufresnes, Brelsford, and Perrin (2014), including most of the loci cross-amplifying in congeners. Maps of *H. molleri*, *H. intermedia*, and *H. orientalis* were adapted from Stöck et al. (2011) and Stöck, Savary, Zaborowska, et al. (2013). Given trans-species similarities in recombination rates, we extrapolated recombination distances to nonavailable peripheral markers for visual comparison (dashed lines). Recombination distances are displayed in centiMorgan.

recombination arrest in the heterogametic sex, which is favored during periods spent as sex chromosome, is neutral during periods spent as autosome (because autosomes recombine anyway in the other gender). Depressed male recombination (possibly the long lasting signature of a sex-chromosome past) will further increase the likelihood that a specific chromosome will recapture a sex-determining role during future turnovers, by providing an initially strong linkage between sex-determining and sexually antagonistic genes (van Doorn and Kirkpatrick 2007). In the present instance, LG1 does show drastically depressed male recombination in all European species investigated, even in those where it is not

sex linked (~30-fold reduction relative to females in *H. sarda* and *H. savignyi*). It is worth noting, however, that amphibians tend to show much lower levels of male recombination over the whole genome (e.g., Nishioka and Sumida 1994; Rodrigues et al. 2013; Betto-Colliard et al. 2015), with a reduction estimated to approximately 14-fold in *H. arborea*, (Berset-Brändli et al. 2008; Dufresnes, Brelsford, and Perrin 2014). An overall low male recombination should not affect the probability that a specific chromosome pair takes over the sex-determination role, but might account for the high frequency of male heterogametic systems. It is also worth noting that LG1 did not show sex differences in recombination in the East

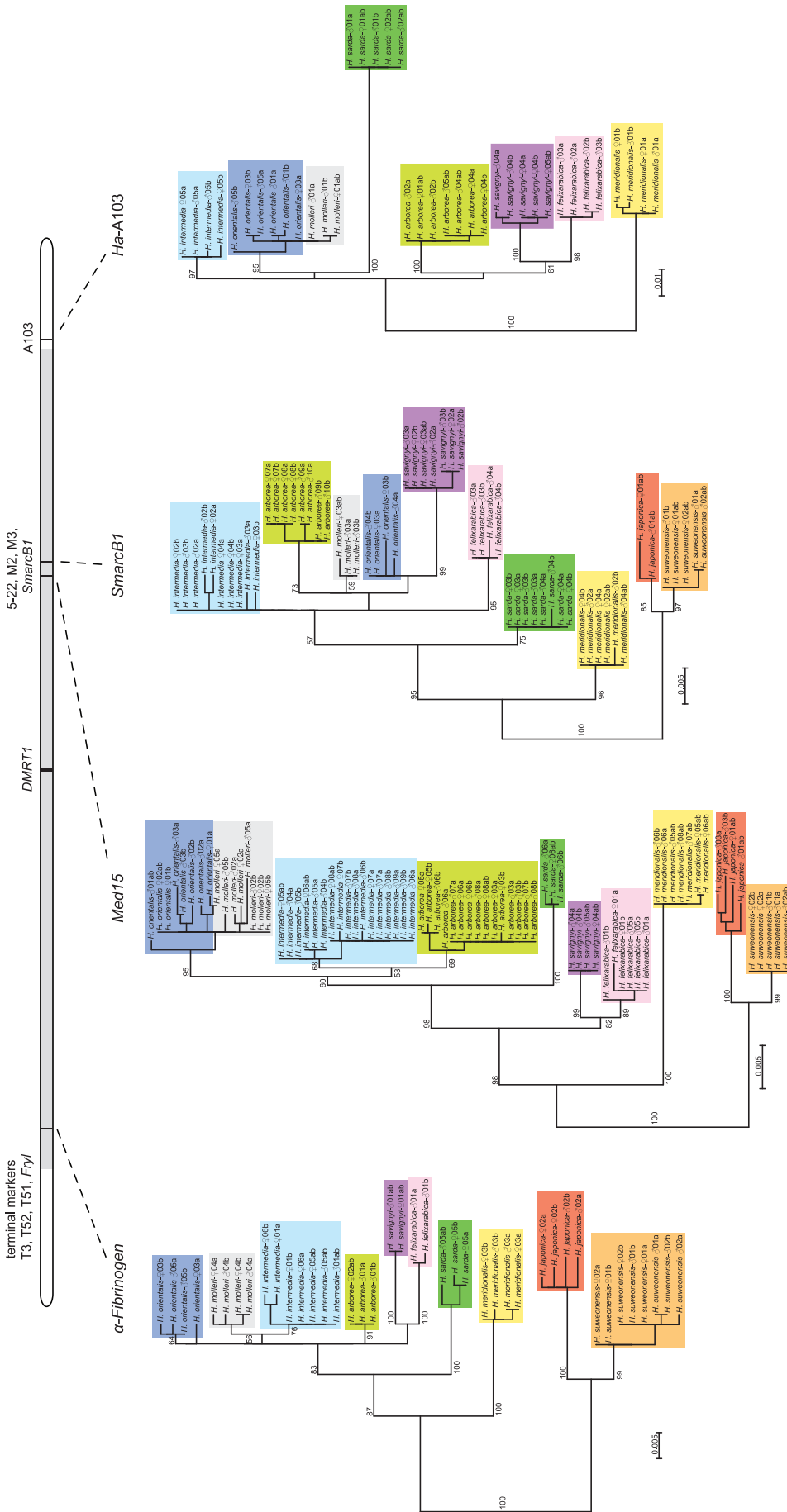

Fig. 3. Maximum-likelihood phylogenies of four LG1-linked markers. The top schematic illustrates rough relative position of these markers across LG1, based on linkage analyses (Fig. 2) and homologies with *Xenopus tropicalis* (Breilford et al. 2013); the shaded area corresponds to the nonrecombining region of European males. Bootstrap values are shown for the main branches, when above 50%. Colors code for species (following Stöck et al. 2012). Sequence labels feature species, sex ID number, and allele (*a*, *b*, or *ab* for homozygotes). Male alleles correspond to X and Y copies in *Hyla arborea*, *H. molleri*, *H. orientalis*, *H. intermedia* and *H. meridionalis*, and female alleles correspond to Z and W copies in *H. suweonensis*; these always group together by species for all four markers, consistent with chromosome-wide occasional X–Y and Z–W recombination. Only the youngest *H. orientalis* (dark blue) and *H. molleri* (gray) show incomplete lineage sorting for *Medf15* and *Ha-A103*.

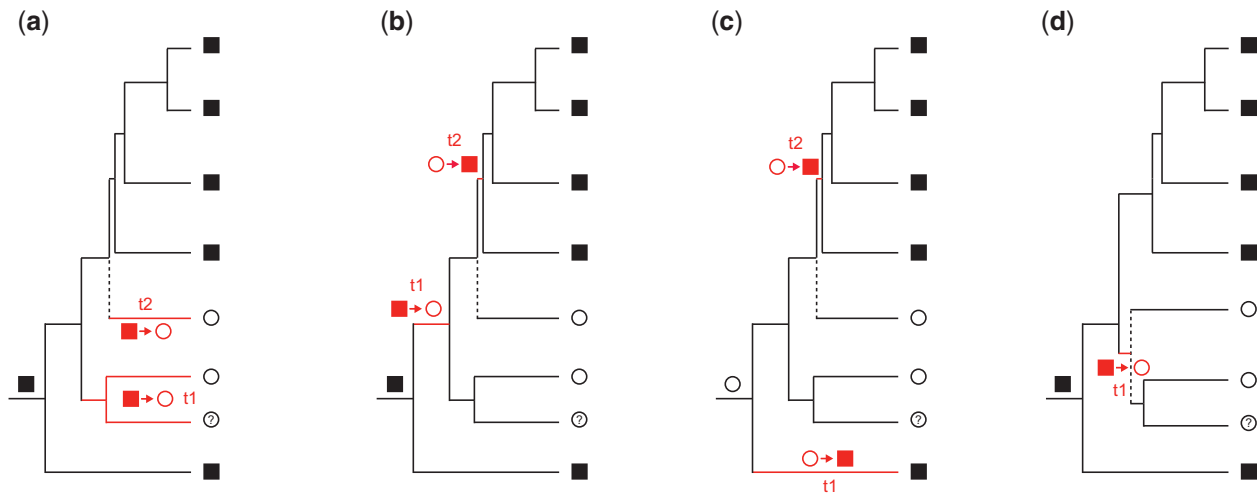

Fig. 4. Parsimonious turnover scenarios accounting for patterns of sex-linkage at LG1 in the European *Hyla* radiation. Trees represent the mtDNA topology (Stöck et al. 2012), which is supported by our GBS data (supplementary file S3, Supplementary Material online) except for the unresolved placement of *Hyla sarda* (dashed lines). Filled squares: Sex-linked (XY), empty circles: Autosomal. Turnover events are indicated in red. (a) Assuming that sex-linkage of LG1 is the ancestral state, two recent turnovers independently occurred within *H. savignyi/felixarabica* (t1) and *H. sarda* (t2) lineages. (b) Assuming that sex-linkage of LG1 is the ancestral state, a first turnover occurred after the split of *H. meridionalis* in the ancestor of *H. savignyi/felixarabica/sarda* (t1), and a second turnover reestablished sex-linkage back to LG1 in the ancestor of *H. arborea/intermedia/orientalis/molleri* (t2). (c) Assuming autosomal location of LG1 as the ancestral state, two independent turnovers recently co-opted LG1 for sex determination within *H. meridionalis* (t1) and in the ancestor of *H. arborea/intermedia/orientalis/molleri* (t2). (d) Alternatively, if *H. sarda* is sister to *H. savignyi/felixarabica*, only one turnover in their common ancestor would explain patterns of sex-linkage at LG1.

Asian *H. japonica*, where it is not sex linked either. Documenting the patterns of heterogamety and recombination across species from this East Asian clade might allow better characterization of the roles of heterogamety and phylogenetic inertia on the evolution of sex-specific recombination rates and turnovers.

In parallel to turnovers, X–Y recombination has been shown to contribute to sex-chromosome homomorphy in closely related species of the *H. arborea* clade (Stöck et al. 2011; Guerrero et al. 2012), in line with similar results obtained from Bufonidae (Stöck, Savary, Betto-Colliard, et al. 2013). Our data provide further support for this mechanism in Hylid frogs, including the deeply diverged *H. meridionalis* and East Asian *H. suweonensis* (where it involves Z–W recombination): In gene genealogies (fig. 3), LG1 sequences always cluster by species (and not by gametologs), with no evidence of haplotype sorting in species where they are sex linked. Occasional recombination is also suggested by the sharing of alleles by X and Y chromosomes in *H. meridionalis*, or Z and W chromosomes in *H. suweonensis*. This might result from occasional or historical recombination in the heterogametic sex (e.g., Dufresnes, Bertholet, et al. 2014), but possibly also from occasional events of sex reversal (the fountain-of-youth model; Perrin 2009), as might be the case, for example, in species where recombination seems entirely arrested in males (fig. 2).

From our results, therefore, two distinct mechanisms, sex-chromosome turnover and X–Y recombination, simultaneously contribute to the homomorphy of sex chromosomes in the Eurasian *Hyla* radiation. These two mechanisms are not to be seen as mutually exclusive, and possibly constitute two alternative responses to the same selective pressures: The accumulation of deleterious mutations on nonrecombining

regions has the potential to induce either X–Y recombination (Grossen et al. 2012) or turnovers (the “hot-potato” model; Blaser et al. 2013, 2014). However, their co-occurrence allows discarding deleterious mutations as a cause of turnovers in *Hyla*, given that sex chromosomes were anyway maintained homomorphic through occasional X–Y recombination. Rejection of the hot-potato model in this case is strengthened by the heterogametic transition suggested in *H. suweonensis*: Mutation-load driven turnovers cannot change the patterns of heterogamety, because the decaying Y or W chromosomes would then have to be fixed as autosomes. Alternatively, turnovers may be driven by sexually antagonistic mutations occurring on autosomes (van Doorn and Kirkpatrick 2007, 2010), or sex-ratio biases induced by environmental changes or genetic conflicts (Grossen et al. 2011; Beukeboom and Perrin 2014), two mechanisms with the potential to induce changes in heterogamety. Further investigations on the patterns of heterogamety, together with identification of the linkage group(s) that determine sex in other species from the European and East Asian Hylid radiations, will contribute to shed light on the underlying mechanisms.

Materials and Methods

Data Generation

Sampling and DNA Extraction

Adult samples comprised males and females from one or more populations of *H. sarda*, *H. savignyi*, *H. meridionalis*, *H. japonica* and *H. suweonensis*, as well as males from *H. felixarabica*. To obtain family samples (parents plus offspring), mating pairs were caught during the breeding season and offspring raised to hatching (see methods in

Dufresnes et al. 2011). For a subset of families, offspring were kept several months after metamorphosis, so that phenotypic sex could be unambiguously determined by morphological identification of gonads (Haczkiwicz and Ogielska 2013). The final pedigree resource totalized 1,896 offspring from 60 informative families of *H. meridionalis*, *H. sarda*, *H. savignyi*, and *H. japonica*, including phenotypically sexed juveniles for the latter three species. Details of sample sizes and origins are provided in [supplementary file S4, Supplementary Material online](#). DNA was sampled using noninvasive buccal swabs (adults; Broquet et al. 2007), or ethanol-fixed tissues (larvae, dissected froglets), and extracted with the Qiagen Biosprint Robotic workstation, or by ammonium acetate separation and ethanol precipitation.

Marker Genotyping and Sequencing

In each species, we tested 15 microsatellite markers shown to be sex-linked in *H. arborea* and mapped as LG1 (Berset-Brändli et al. 2008; Dufresnes, Brelsford, and Perrin 2014). These include the 14 loci used by Dufresnes, Bertholet, et al. (2014; see their supplementary file S2 for the list of markers and methods), plus one additional microsatellite located within intron 7 of the gene *SmarcB1* (methods: Brelsford et al. 2013). Primers were redesigned for amplifying microsatellite *Ha-A103* (forward: 5'-GGGACCTATGGATTAAG-3'; reverse: 5'-CAATTCACACCCAAATCAGAT-3'). Polymerase chain reaction (PCR) products were run on an ABI-3100 genetic analyzer (Applied Biosystem, Inc.), and peaks were scored with Genemapper 4.0 (Applied Biosystems, Inc.). For each species, usable loci were genotyped in all adults and families. In species where LG1 showed no evidence for sex linkage (see Results), we genotyped additional microsatellites available for Palearctic *Hyla* and mapping to other linkage groups (Dufresnes, Brelsford, Béziers, et al. 2014; Dufresnes, Brelsford, and Perrin 2014, and methods therein).

We generated sequence data from four markers widely distributed across LG1 in adults from both sexes of each species under focus when possible, in complement to published sequences (Stöck et al. 2011; Dufresnes, Stöck, et al. 2014). The four markers consisted of parts of the gene *Med15* (~1,000 bp, plus a ~600-bp insertion in *H. sarda*, encompassing introns 7, 8 and exons 7, 8), intronic sequences from the genes *SmarcB1* (~500 bp encompassing intron 7) and *a-Fibrinogen* (~500 bp encompassing intron 1), and flanking regions of the noncoding microsatellite *Ha-A103* (~500 bp, plus a ~700-bp insertion in *H. meridionalis*). PCRs were carried out as described (*Med15*, *a-Fibrinogen* and *Ha-A103*: Stöck et al. 2011; *SmarcB1*: Brelsford et al. 2013), using redesigned primers for *Med15* (forward: 5'-TAGCATTAGCTATTAAGCATACTCG-3', reverse: 5'-TTACAGCAACAGCAAATGG-3'), *a-Fibrinogen* (forward: 5'-AGATACAGTCACAGTGCTAGGTT C-3', reverse: 5'-GGAGGATATCAGCACAGTCTAAA-3') and *Ha-A103* (forward: 5'-ATGAATGGGCAAACCTTCCAT-3', reverse: 5'-GCCTAGAAATGTGCAGTGATC-3', for *H. meridionalis*, forward: 5'-CCAAGACCTCTTGCCAACATTAGT-3'), optimized for cross-amplification. PCR products were cloned with the TOPO TA cloning kit (Life Technologies) or pGEM-easy vector system (Promega), from which at

least eight clones per sample were sequenced. A few samples were sequenced directly (*SmarcB1*, $n = 13$). In these cases, heterozygous positions were visualized from electropherograms in MEGA 5.0 (Tamura et al. 2011). All sequences were edited and aligned in SeaView (Gouy et al. 2010). Only *Ha-A103* sequences could not be generated in the two East Asian species. Samples origins and GenBank accessions are provided in [supplementary file S4, Supplementary Material online](#).

GBS Library Preparation and SNP Calling

We prepared a GBS library for seven European *Hyla* (all species but *H. felixarabica*, four individuals per species) using a protocol modified from Parchman et al. (2012) and Purcell et al. (2014). Sample origins and the complete protocol are available in [supplementary file S5, Supplementary Material online](#). Briefly, we digested genomic DNA with restriction enzymes *EcoRI* and *MseI*, ligated barcoded adapters, PCR-amplified the resulting fragments, and selected PCR products between 400 and 500 bp. One of the PCR primers included a selective nucleotide, designed to target the subset of restriction fragments containing a G nucleotide adjacent to the *MseI* restriction site. The resulting library was sequenced on a single Illumina HiSeq 2000 lane at the Lausanne Genomics Technology Facility.

Raw sequence files were demultiplexed using the `process_radtags` module of Stacks 1.24 (Catchen et al. 2011). We ran the Stacks `denovo_map.pl` pipeline with minimum stack depth (-m) 2, mismatches allowed between loci (-n) 4, upper boundary for error rate (-bound_high) 0.05, and default values for other parameters. We then exported SNPs with fixed differences among species in Phylip format, producing one data set with only SNPs genotyped in at least one individual of all seven species, and one retaining SNPs genotyped in at least one individual of at least three species.

Data Analyses

Sex Linkage

Sex linkage was ascertained on two grounds. First, we compared sex-specific allelic frequencies in male and female adults, testing for sex-specific differentiation (F_{ST} ; Goudet 1995). Sex-linked loci are expected to carry sex-specific alleles and genotypes resulting in genetic differentiation between sexes (positive F_{ST}). Sex linkage of specific alleles was also tested with combinatory statistics. Second, we used Fisher's exact tests in families with phenotypically sexed offspring to test for sex-specific inheritance of maternal or paternal alleles (e.g., Rodrigues et al. 2013).

Linkage Maps

Species- and sex-specific microsatellite linkage maps of LG1 were computed using CRIMAP (Green et al. 1990). For each species, we first calculated the most likely order of loci with LOD (logarithm of the odds) scores (functions *all* and *flips*) and then estimated sex-specific recombination distances (function *build*). Final maps were produced with MapChart (Voorrips 2002).

Phylogeny of LG1 Sequences

We performed separate maximum-likelihood phylogenetic reconstructions of *Med15*, *SmarcB1*, *a-Fibrinogen* and *Ha-A103* sequences with PhyML (Guindon et al. 2009), using, respectively, GTR + G, GTR + G, HKY + G and GTR models of sequence evolution (MrAIC; Nylander 2004) and 1,000 bootstrap replicates. To avoid artifacts due to misalignments, microsatellite-like indels were discarded from the analyses. Following the rationale of Stöck et al. (2011; see their figure 1), X and Y alleles are expected to cluster by gametologs in absence of sex chromosome recombination, but by species otherwise.

Species Trees and Phylogenetic Inferences Based on GBS

Data

We refer to Stöck et al. (2012) and Smith et al. (2005) for mitochondrial phylogenetic relationships and molecular clock-calibrated divergence times in the considered *Hyla* species (fig. 1). In complement, the position of *H. suweonensis* was inferred from published mitochondrial *cytochrome-b* (*cyt-b*) sequences (GenBank KF564855–KF564864), branched on the *cyt-b* tree of Stöck et al. (2012) using a similar maximum-likelihood reconstruction.

We performed Bayesian phylogenetic inferences of our GBS data sets with MrBayes 3.1 (Ronquist and Huelsenbeck 2003), allowing for mixed molecular evolution models. Two independent chains were run for 2 million iterations, each sampling every 1,000. After checking for convergence, the first 10% of sampled trees were discarded as burn-in and consensus trees were estimated.

To estimate the position of *H. sarda* relative to *H. savignyi* (see Results), we tested for significant differences in support for three alternative relationships between *H. meridionalis*, *H. sarda*, *H. savignyi*, and the *H. arborea* clade, using the S-H test implemented in the R package phangorn (Schliep 2011).

Supplementary Material

Supplementary files S1–S5 are available at *Molecular Biology and Evolution* online (<http://www.mbe.oxfordjournals.org/>).

Acknowledgments

The authors thank A. Olivier, M. Delaugerre and F. Baier for their contributions to the sampling, as well as Karim Ghali for help with raising frogs and Nicolas Salamin for assistance with phylogenetic analyses. Analyses of GBS data were performed at the Vital-IT (<http://www.vital-it.ch>) Center for high-performance computing of the SIB Swiss Institute of Bioinformatics. This work was supported by the Swiss National Science Foundation (grant 31003A_129894) to N.P. and the University of Lausanne (PhD fellowship from the Faculty of Biology and Medicine) to C.D.

References

Anderson K. 1991. Chromosome evolution in Holarctic *Hyla* treefrogs. In: Green DM, Session SK, editors. Amphibians' cytogenetics and evolution. San Diego: Academic Press. p. 299–312.

Bachtrog D. 2013. Y-chromosome evolution: emerging insights into processes of Y-chromosome degeneration. *Nat Rev Genet.* 14:113–124.

Bachtrog D, Mank JE, Peichel CL, Kirkpatrick M, Otto SP, Ashman TL, Hahn MW, Kitano J, Mayrose I, Ming R, et al. 2014. Sex determination: why so many ways of doing it? *PLoS Biol* 12:e1001899.

Berset-Brändli L, Jaquiéry J, Broquet T, Ulrich Y, Perrin N. 2008. Extreme heterochiasmy and nascent sex chromosomes in European tree frogs. *Proc Biol Sci.* 275:1577–1585.

Berset-Brändli L, Jaquiéry J, Dubey S, Perrin N. 2006. A sex-specific marker reveals male heterogamety in European tree frogs. *Mol Biol Evol.* 23:1104–1106.

Betto-Colliard C, Sermier R, Litvinchuk S, Perrin N, Stöck M. 2015. Origin and genome evolution of polyploidy green toads in Central Asia: evidence from microsatellite markers. *Heredity* 114:300–308.

Beukeboom LW, Perrin N. 2014. The evolution of sex determination. Oxford: Oxford University Press.

Blaser O, Grossen C, Neuenschwander S, Perrin N. 2013. Sex-chromosome turnovers induced by deleterious mutation load. *Evolution* 67:635–645.

Blaser O, Neuenschwander S, Perrin N. 2014. Sex-chromosome turnovers: the hot-potato model. *Am Nat.* 183:140–146.

Brelsford A, Stöck M, Betto-Colliard C, Dubey S, Dufresnes C, Jourdan-Pineau H, Rodrigues N, Savary R, Sermier R, Perrin N. 2013. Homologous sex chromosomes in three deeply divergent anuran species. *Evolution* 67:2434–2440.

Broquet T, Berset-Brändli L, Emaresi G, Fumagalli L. 2007. Buccal swabs allow efficient and reliable microsatellite genotyping in amphibians. *Conserv Genet.* 8:509–511.

Catchen JM, Amores A, Hohenlohe P, Cresko W, Postlethwait JH. 2011. Stacks: building and genotyping loci de novo from short-read sequences. *G3* 1:171–182.

Charlesworth D, Charlesworth B. 2000. The degeneration of Y chromosomes. *Philos Trans R Soc Lond B Biol Sci.* 355:1563–1572.

Cortez D, Marin R, Toledo-Flores D, Froidevaux L, Liechti A, Waters PD, Grütznér F, Kaessmann H. 2014. Origins and functional evolution of Y chromosomes across mammals. *Nature* 508:488–493.

Dufresnes C, Luquet E, Plenet S, Stöck M, Perrin N. 2011. Polymorphism at a sex-linked transcription cofactor in European tree frogs (*Hyla arborea*): sex-antagonistic selection or neutral processes? *Evol Biol.* 38:208–213.

Dufresnes C, Brelsford A, Béziers P, Perrin N. 2014. Stronger transferability but lower variability in transcriptomic- than in anonymous microsatellites: evidence from Hylid frogs. *Mol Ecol Resour.* 14:716–725.

Dufresnes C, Brelsford A, Perrin N. 2014. First-generation linkage map for the European tree frog (*Hyla arborea*) with utility in congeneric species. *BMC Res Notes.* 7:850.

Dufresnes C, Bertholet Y, Wassef J, Ghali K, Savary R, Pasteur B, Brelsford A, Rozenblut-Kościsty B, Ogielska M, Stöck M, et al. 2014. Sex-chromosome differentiation parallels postglacial range expansion in European tree frogs (*Hyla arborea*). *Evolution* 68:3445–3456.

Dufresnes C, Stöck M, Brelsford A, Perrin N. 2014. Range-wide sex-chromosome sequence similarity supports occasional XY recombination in European tree frogs (*Hyla arborea*). *PLoS One* 9:e97959.

Goudet J. 1995. FSTAT (version 1.2): a computer program to calculate F-Statistics. *J Hered.* 86:485–486.

Gouy M, Guindon S, Gascuel O. 2010. SeaView version 4: a multiplatform graphical user interface for sequence alignment and phylogenetic tree building. *Mol Biol Evol.* 27:221–224.

Graves JAM, Peichel CL. 2010. Are homologies in vertebrate sex determination due to shared ancestry or to limited options? *Genome Biol* 11:205–216.

Green P, Falls KA, Crooks S. 1990. CRIMAP 2.4. St Louis (MO): Washington University, School of Medicine. Available from: <http://linkage.rockefeller.edu/soft/crimap/>.

Grossen C, Neuenschwander S, Perrin N. 2011. Temperature-dependent turnovers in sex-determination mechanism: a quantitative model. *Evolution* 65:64–78.

Grossen C, Neuenschwander S, Perrin N. 2012. The evolution of XY recombination: sexually antagonistic selection versus deleterious mutation load. *Evolution* 66:3155–3166.

- Guerrero RF, Kirkpatrick M, Perrin N. 2012. Cryptic recombination in the ever-young sex chromosomes of Hylid frogs. *J Evol Biol.* 25:1947-1954.
- Guindon S, Delsuc F, Dufayard JF, Gascuel O. 2009. Estimating maximum likelihood phylogenies with PhyML. *Methods Mol Biol.* 537:113-137.
- Haczkiwicz K, Ogielska M. 2013. Gonadal sex differentiation in frogs: how testes become shorter than ovaries. *Zool Sci.* 30:125-134.
- Kawamura T, Nishioka M. 1977. Aspects of the reproductive biology of Japanese anurans. In: Taylor DH, Guttman SI, editors. *The reproductive biology of amphibians*. New York: Plenum. p. 103-139.
- Kikuchi K, Hamaguchi S. 2013. Novel sex-determining genes in fish and sex chromosome evolution. *Dev Dyn.* 242:339-353.
- Kitano J, Peichel CL. 2011. Turnover of sex chromosomes and speciation in fishes. *Environ Biol Fish.* 94:549-558.
- Malcom JW, Kudra RS, Malone JH. 2014. The sex chromosomes of frogs: variability and tolerance offer clues to genome evolution and function. *J Genomics.* 2:68-76.
- Mank JE, Avise JC. 2009. Evolutionary diversity and turnover of sex determination in teleost fishes. *Sex Dev.* 3:60-67.
- Matson CK, Zarkower D. 2012. Sex and the singular DM domain: insights into sexual regulation, evolution and plasticity. *Nat Rev Genet.* 13:163-174.
- Miura I. 2007. An evolutionary witness: the frog *Rana rugosa* underwent change of heterogametic sex from XY male to ZW female. *Sex Dev.* 1:323-331.
- Nishioka M, Sumida M. 1994. The differences in recombination rate between male and female in *Rana nigromaculata* and *Rana brevipedo*. *Sci Rep Lab Amphibian Biol Hiroshima Univ.* 13:99-136.
- Nylander JAA. 2004. MrAIC.pl. Program, distributed by the author. Evolutionary Biology Centre, Uppsala University, Uppsala, Sweden.
- O' Meally D, Ezaz T, Georges A, Sarre SD, Graves JAM. 2012. Are some chromosomes particularly good at sex? Insights from amniotes. *Chromosome Res.* 20:7-19.
- Parchman TL, Gompert Z, Mudge J, Schilkey FD, Benkman CW, Buerkle C. 2012. Genome-wide association genetics of an adaptive trait in lodgepole pine. *Mol Ecol.* 21:2991-3005.
- Perrin N. 2009. Sex-reversal, a fountain of youth for sex chromosomes? *Evolution* 63:3043-3049
- Purcell J, Brelsford A, Wurm Y, Perrin N, Chapuisat M. 2014. Convergent genetic architecture underlies social organization in ants. *Curr Biol.* 24:2728-2732.
- Pyron RA, Wiens JJ. 2011. A large-scale phylogeny of Amphibia including over 2800 species, and a revised classification of extant frogs, salamanders, and caecilians. *Mol Phylogenet Evol.* 61:543-583.
- Rodrigues N, Betto-Colliard C, Jourdan-Pineau H, Perrin N. 2013. Within-population polymorphism of sex-determination systems in the common frog (*Rana temporaria*). *J Evol Biol.* 26:1569-1577.
- Ronquist F, Huelsenbeck JP. 2003. MrBayes 3: Bayesian phylogenetic inference under mixed models. *Bioinformatics* 19:1572-1574
- Schartl M. 2004. Sex chromosome evolution in non-mammalian vertebrates. *Curr Opin Genet Dev.* 14:634-641.
- Schliep KP. 2011. phangorn: phylogenetic analysis in R. *Bioinformatics* 27:592-593.
- Smith CA, Roeszler K, Ohnesorg T, Cummins DM, Farlie PG, Doran TJ, Sinclair AH. 2009. The avian Z-linked gene *DMRT1* is required for male sex-determination in the chicken. *Nature* 461:267-271.
- Smith SA, Stephens PR, Wiens JJ. 2005. Replicate patterns of species richness, historical biogeography, and phylogeny in Holarctic treefrogs. *Evolution* 59:2433-2450.
- Stöck M, Dufresnes C, Litvinchuk SN, Lymberakis P, Biollay S, Berroneau M, Borzée A, Ghali K, Ogielska M, Perrin N. 2012. Cryptic diversity among Western Palearctic tree frogs: postglacial range expansion, range limits, and secondary contacts of three European tree frog lineages (*Hyla arborea* group). *Mol Phylogenet Evol.* 65:1-9.
- Stöck M, Horn A, Grossen C, Lindtke D, Sermier R, Betto-Colliard C, Dufresnes C, Bonjour E, Dumas Z, Luquet E, et al. 2011. Ever-young sex chromosomes in European tree frogs. *PLoS Biol.* 9:e1001062.
- Stöck M, Savary R, Betto-Colliard C, Biollay S, Jourdan-Pineau H, Perrin N. 2013. Low rates of X-Y recombination, not turnovers, account for homomorphic sex chromosomes in several diploid species of Palearctic green toads (*Bufo viridis* subgroup). *J Evol Biol.* 26:674-682.
- Stöck M, Savary R, Zaborowska A, Górecki G, Brelsford A, Rozenblut-Kocisty B, Ogielska M, Perrin N. 2013. Maintenance of ancestral sex chromosomes in Palearctic tree frogs: direct evidence from *Hyla orientalis*. *Sex Dev.* 7:261-266.
- Tamura K, Peterson D, Peterson N, Stecher G, Nei M, Kumar S. 2011. MEGA5: Molecular Evolutionary Genetics Analysis using maximum likelihood, evolutionary distance, and maximum parsimony methods. *Mol Biol Evol.* 28:2731-2739.
- van Doorn GS, Kirkpatrick M. 2007. Turnover of sex chromosomes induced by sexual conflict. *Nature* 449:909-912.
- van Doorn GS, Kirkpatrick M. 2010. Transitions between male and female heterogamety caused by sex-antagonistic selection. *Genetics* 186:629-645.
- Volff JN, Nanda I, Schmid M, Schartl M. 2007. Governing sex determination in fish: regulatory putches and ephemeral dictators. *Sex Dev.* 1:85-99.
- Voorrips RE. 2002. MapChart: software for the graphical presentation of linkage maps and QTLs. *J Hered.* 93:77-78.
- Yu SL, Lee HY. 1990. Comparative karyological analysis of Korean tree frogs, *Hyla japonica* and *Hyla suweonensis* (Anura, Hylidae). *Korean J Zool.* 33:1-5.