



ELSEVIER

European Journal of Cardio-thoracic Surgery 19 (2001) 424–430

EUROPEAN JOURNAL OF
CARDIO-THORACIC
SURGERYwww.elsevier.com/locate/ejts

Fibrin gel – advantages of a new scaffold in cardiovascular tissue engineering[☆]

Stefan Jockenhoevel^{a,b,*}, Gregor Zund^b, Simon P. Hoerstrup^b, Khaled Chalabi^a,
Jörg S. Sachweh^a, Lütfü Demircan^a, Bruno J. Messmer^a, Marko Turina^b

^aClinic for Thoracic and Cardiovascular Surgery, University Hospital Aachen, Pauwelsstrasse 30, 52074 Aachen, Germany

^bClinic for Cardiovascular Surgery, University Hospital Zurich, Zurich, Switzerland

Received 11 October 2000; received in revised form 31 January 2001; accepted 14 February 2001

Abstract

Objective: The field of tissue engineering deals with the creation of tissue structures based on patient cells. The scaffold plays a central role in the creation of 3-D structures in cardiovascular tissue engineering like small vessels or heart valve prosthesis. An ideal scaffold should have tissue-like mechanical properties and a complete immunologic integrity. As an alternative scaffold the use of fibrin gel was investigated. **Methods:** Preliminary, the degradation of the fibrin gel was controlled by the supplementation of aprotinin to the culture medium. To prevent tissue from shrinking a mechanical fixation of the gel with 3-D microstructure culture plates and a chemical fixation with poly-L-lysine in different fixation techniques were studied. The thickness of the gel layer was changed from 1 to 3 mm. The tissue development was analysed by light, transmission and scanning electron microscopy. Collagen production was detected by the measurement of hydroxyproline. Injection molding techniques were designed for the formation of complex 3-D tissue structures. **Results:** The best tissue development was observed at an aprotinin concentration of 20 µg per cc culture medium. The chemical border fixation of the gel by poly-L-lysine showed the best tissue development. Up to a thickness of 3 mm no nutrition problems were observed in the light and transmission electron microscopy. The molding of a simplified valve conduit was possible by the newly developed molding technique. **Conclusion:** Fibrin gel combines a number of important properties of an ideal scaffold. It can be produced as a complete autologous scaffold. It is moldable and degradation is controllable by the use of aprotinin. © 2001 Elsevier Science B.V. All rights reserved.

Keywords: Tissue engineering; Autologous human tissue; Cardiovascular; Scaffolds

1. Introduction

The field of tissue engineering provides an alternative to organ and tissue transplants based on the limited supply of donor organs. Isolated cells are commonly used to engineer new tissues. The cells will be seeded on a three dimensional scaffold followed by in vitro culturing. In a second step the newly formed structure will be seeded with autologous endothelial cells to create a viable, active surface with high biocompatibility.

The scaffolds serve as physical supports and templates for cell attachment and tissue development. With the principles of tissue engineering, the creation of new tissues in cardio-

vascular surgery will be realized, such as heart valves, cardiac muscles, pericardium, and vessels [1–3].

The requirements for an ideal scaffold are the easy handling and molding of complex 3-D structures like valve conduits or vessels with complex side branches. The material should not be toxic or have any immunologic side effects. The diffusion barrier of the scaffold has to be as low as possible to guarantee an optimal nutrition in thicker tissues. The mechanical as well as the chemical properties (e.g. the integration of growth factors) should be modifiable. The control of the degradation is important to adapt the structural support of the scaffold to the tissue development.

Many substances are used in the production of scaffolds, e.g. synthetic polymers (polyurethanes (PUR), polyglycolic acid (PGA), polylactic acid (PLA), polyhydroxybutyrate (PH4B), copolymers of lactic and glycolic acids, polyanhydrides, polyortho esters) and natural polymers (chitosan, glycosaminoglycans, collagen) or biological scaffolds like acellularized porcine aortic conduits [4–7]. Scaffold-related

[☆] Presented at the 14th Annual Meeting of the European Association of Cardio-thoracic Surgery, Frankfurt, Germany, October 7–11, 2000.

* Corresponding author. Tel.: +49-24-1808-9956; fax: +49-24-1888-8454.

E-mail address: stjocke@yahoo.com (S. Jockenhoevel).

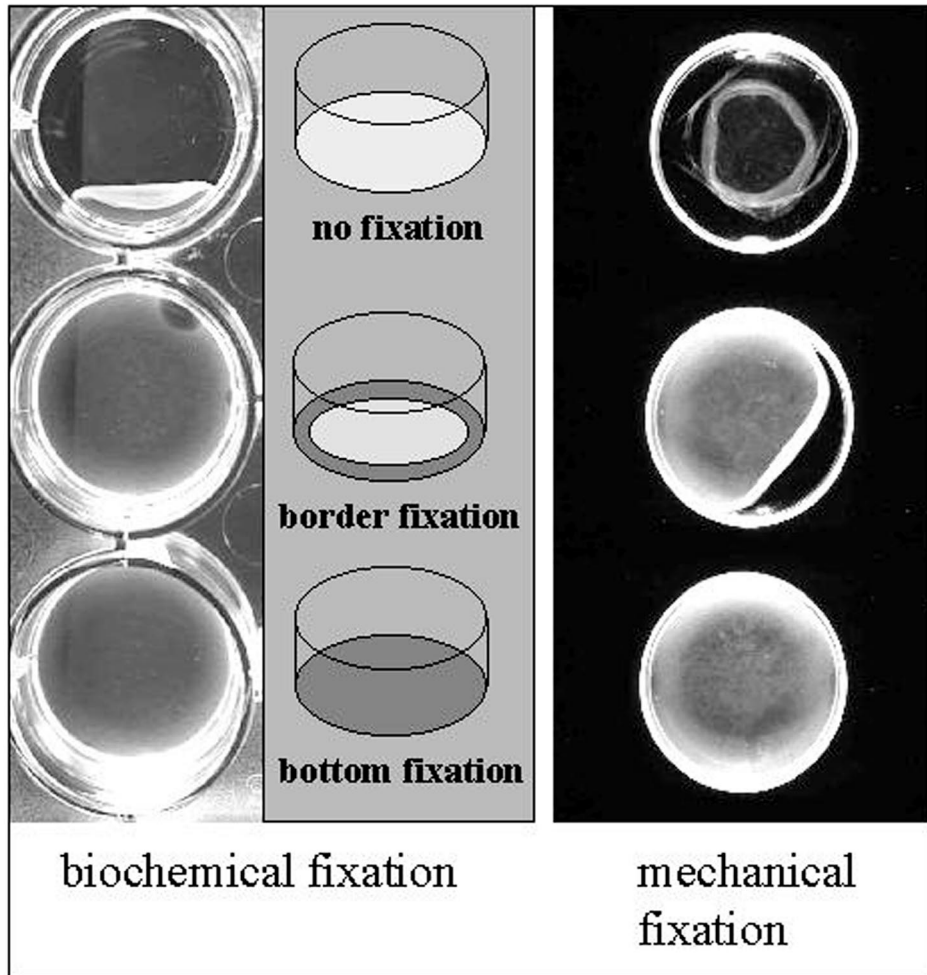

Fig. 1. Biochemical vs. mechanical method of gel fixation: the biochemical fixation was investigated in two different fixation techniques, bottom vs. border fixation (left). The mechanical fixation was realized by a 3-D microstructured Tissue Culture Polyesterene Plate (3-D TCPS) (Integra Bioscience Inc., Switzerland) (right).

problems like cytotoxic degradation products, fixed degradation times, limited mechanical properties and the absence of a growth modulation etc. make further extensive investigations on the ideal scaffold necessary.

The creation of complex 3-D cardiovascular structures is the aim of our investigations. With the conventionally used scaffolds the formation of different layer thickness is problematic and depends on the production limit of the scaffold thickness. The connection of the different components like the cusps with the vascular wall is also problematic. The production of the complete structure in one part with a biodegradable polymer in an injection molding technique will solve several important problems.

Fibrin gel as such is a biodegradable polymer. It can be produced from the patient's own blood and used as an autologous scaffold for the seeded fibroblasts without the potential risk of a foreign body reaction. The use of fibrin gel as an "ideal" scaffold for cardiovascular tissue engineering was investigated in our research group:

The following characterization of the fibrin gel was

necessary to define the boundary conditions for a molding technique.

1. The degradation of the gel takes place within a few days by the plasminogen in the culture medium. Successful degradation control will make the use of fibrin gel possible. As reported previously, the best tissue development was observed by a degradation control with 20 $\mu\text{g/ml}$ aprotinin supplemented to the medium [8].
2. In the injection molding technique the vascular wall and the cusp is formed by the same scaffold. The construction of thicker structures is limited, because the exchange of the nutrients in the tissue engineered structures without vasa vasorum can only take place by diffusion. On this account, the tissue development initially depends on the diffusion resistance of the tissue/scaffold in terms of a good nutritional supply and removal of the metabolic substances.
3. The phenomenon of tissue shrinking is a product of structural changes in the scaffold and the contraction of the

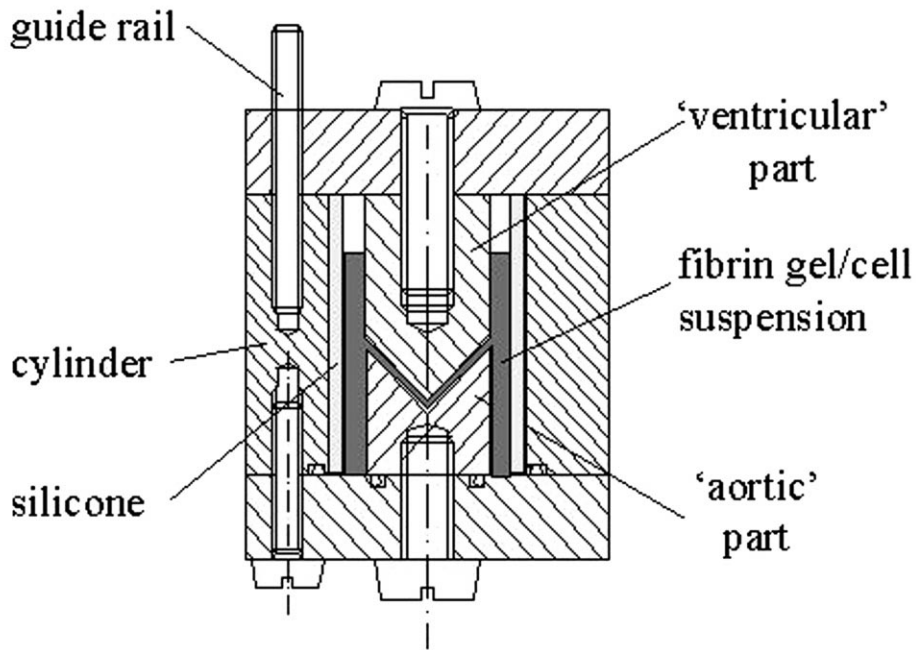

Fig. 2. Mold for the formation of a simplified aortic root: the outer cylinder is coated by a variable silicon layer. The inner part of the conduit will be formed by the “aortic” and the “ventricularis” stamp. The distance between the stamps is variable.

- new synthesized collagen bundles. The prevention of tissue shrinking is essentially to get functional tissues.
4. The molding technique itself is complex and in this study the following questions were evaluated in a simplified model of a valve conduit: (1) mix technique regarding to the limited polymerization time of the gel, (2) gel adherence to the mold, and the (3) feasibility of molding complex structures with a different layer thickness in the vascular and the cusps part.

2. Material and methods

2.1. The production of viable cardiovascular structures bases on an suspension of myofibroblasts and the fibrin gel

2.1.1. Cell culturing

Mixed cell cultures were obtained from human ascending aorta of explanted hearts. The myofibroblast cells were cultured in the ‘basic medium’, which consists of Dulbecco’s modified Eagle’s medium supplemented with 10% fetal bovine serum and 1% antibiotic-antimycotic solution (Gibco BRL-Life Technologies, Grand Island, NY). To obtain sufficient cell numbers, cells were serially passaged three to four times.

2.1.2. Fibrin gel production

Fibrinogen from human plasma being plasminogen free (Fluka Inc.) was dissolved in water and dialysed with a cutoff membrane of 6-8.000 MW overnight against Tris

buffered saline. The fibrinogen solution was serial filtered and sterilized. 10 % 50 mM CaCl₂, 20% Thrombin (20 units/ml) and 70% resuspended cells in Tris buffered saline were mixed gently. The fibrinogen was added in a ratio 1:1 and mixed by gently shaking.

The tissue was cultured with ‘basic medium’ supplemented with 1 mM L-ascorbic acid 2-phosphate to increase the collagen production [9].

A degradation control of the scaffold is desirable to adapt the scaffold degradation to the tissue development, this degradation of the gel was controlled by the supplementation of aprotinin (20 µg/ml medium) [8].

2.2. Variation of the layer thickness

The thickness of the gel layer was varied from 1 to 3 mm with 1 mm steps ($n = 4$ per group). All gels were fixed by a border fixation with a 0.01% poly-L-lysine solution as described below.

Prevention of tissue shrinking was investigated by different fixation methods. Furthermore the fixation of the gel on the one hand and the tendency of shrinking on the other hand might lead to a positive mechanical stress in the tissue, which might induce the collagen production and thereby the mechanical properties of the tissue. For this reason a complete bottom fixation ($n = 4$) was different from a small border fixation (2 mm) ($n = 4$) to investigate the influence on the tissue development in the biochemical fixation method (see Fig. 1, left side).

The biochemical fixation were realized with a 0.01% solution of poly-L-lysine. The poly-L-lysine were air dried

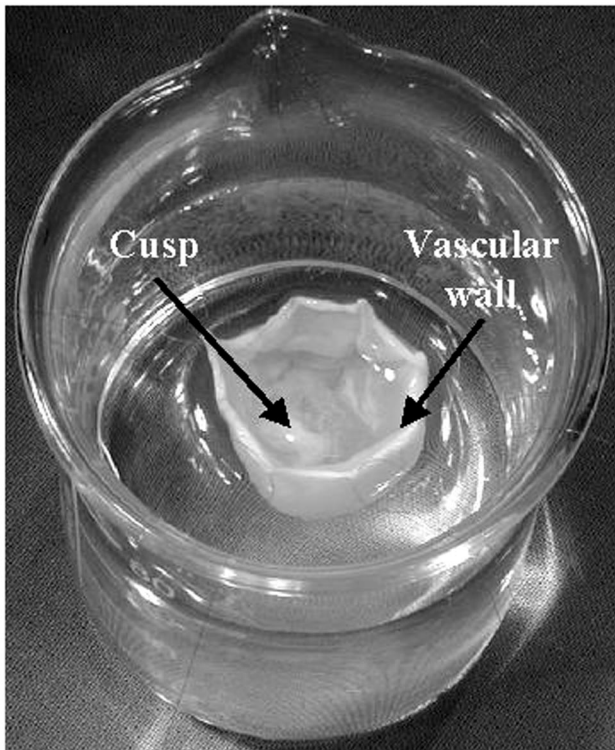

Fig. 3. Model of a valve conduit based on a molded fibrin gel scaffold.

and afterwards washed with phosphate buffered saline. Wells without coating were used as a control ($n = 4$).

The cytotoxic side-effects of poly-L-lysine in higher concentrations is known. As an alternative, a mechanical fixation was investigated with a new available 3-D micro-structured Tissue Culture Polystyrol Plate (3-D TCPS)

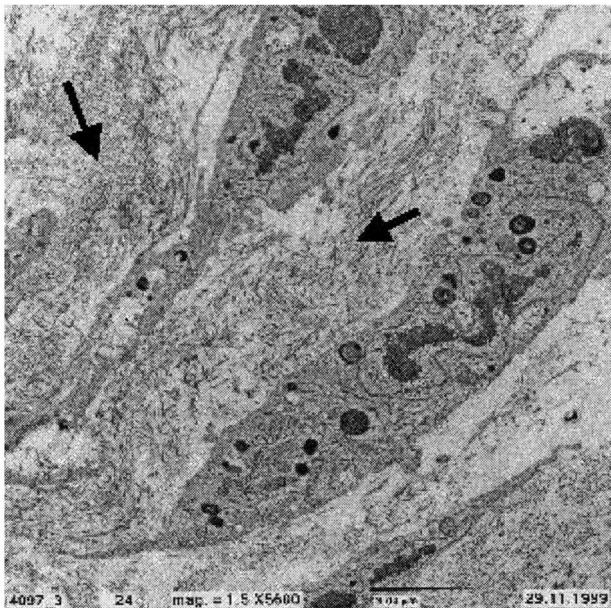

Fig. 4. Fibrin gel after a culturing period of 4 weeks with well developed extracellular matrix and organized collagen bundles (arrow).

(Integra Bioscience Inc., Switzerland) ($n = 12$). The squared 3-D structure of the plate was used to fix the gel in the primary position (see Fig. 1, right side). Biochemical border fixed fibrin gel was used as a control ($n = 6$).

2.3. Molding technique

A molding technique was generated for the creation of a simplified valve conduit. To test the feasibility of such a molding technique, simplified aluminum 'ventricular' and 'aortic' stamps were formed and coated with a thin silicone layer. The distance between the two parts is adjustable to get different cusp thickness. The mold is circumferentially limited by a silicone coated aluminum cylinder (Fig. 2). The cell suspension of myofibroblasts in Tris saline solution supplemented with calcium and thrombin was filled in the mold with the 'aortic' stamp in a water bath at 37°C. The polymerization of the fibrin gel was started in the mold after the supplementation of fibrinogen. Within a few seconds the 'ventricularis' stamp was fit in the mold along the guide rail and moved gently to eliminate air bubbles. After an incubation time of 1 h the cast was carefully removed.

The tissue development was investigated histologically and biochemically regarding the collagen production. For the histological evaluation specimens were fixed in 4% formalin and stained by haematoxylin and eosin as well as Masson's trichrome. Transmission electron microscopy specimens were fixed with Na-Cacodylat-buffered glutaraldehyde (2.5%) and paraformaldehyde (0.8%), and were post-fixed with 1% osmium tetroxide, dehydrated in a series of alcohol, and embedded. Ultra-thin sections were stained with uranyl acetate and lead citrate. The specimens were investigated under light microscopy and transmission electron microscopy.

The hydroxyproline assay was performed as a marker of the collagen production and the tissue development to the method of Reddy et al. [10].

2.4. Statistics

The data are expressed as mean \pm SD of the mean. Student's *t*-test was used to assess the modifying effect of the different fixation methods and the threshold for statistical significance was set at $P < 0.05$.

3. Results

Fig. 3 demonstrates the simplified valve conduit based on the newly developed molding technique. The tissue was easily peeled off the mold and the silicon coated 'ventricularis' and 'aortic' stamp could also be pulled out easily. After the retraction of the gel, the thickness of the vascular wall was circa 2 mm and the layer thickness of the cusps was around 0.5 mm. The tissue was sutureable, but the initial stiffness of the gel construction was too low for a direct implantation.

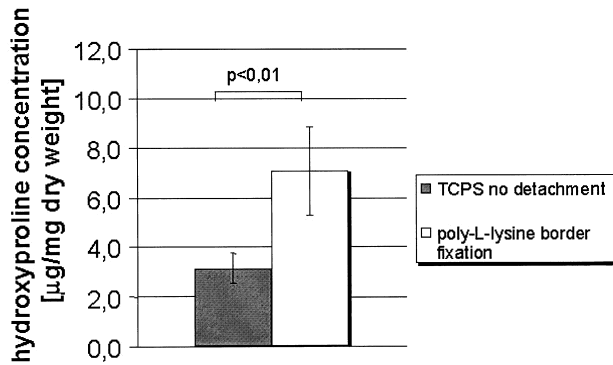

Fig. 5. Hydroxyproline concentration regard to the fixation method: mechanical fixation with a 3-D TCPS vs. biochemical border fixation with poly-L-lysine.

The microscopic evaluation of the gels showed an homogenous cell distribution. No cell necrosis in the light microscopic and transmission electron microscopic evaluations was observed up to a layer thickness of 3 mm. Fig. 4 shows the transmission electron microscopic picture of fibrin gel tissue after a culturing period of 4 weeks. The tissue consists of viable cells surrounded by a well developed extracellular matrix with organized collagen bundles.

The prevention from shrinking in the mechanical fixed group showed two of 12 partial and four of 12 complete tissue detachments vs. no detachment in the poly-L-lysine border fixed control group (Fig. 1, right side). The concentration of hydroxyproline was significantly higher ($P < 0.05$) in poly-L-lysine fixed group ($7.1 \mu\text{g}/\text{mg} \pm 1.78$) than in the non-detached mechanical fixed group ($4.8 \mu\text{g}/\text{mg} \pm 0.6$) (Fig. 5).

The control group showed a shrinking to a size less than 30% of the initial seeded area in the biochemical fixation tests with poly-L-lysine (Fig. 1, left side). No shrinking was observed in the bottom or border fixed group. After a culturing period of 50 days the highest concentration of hydroxyproline was detected in the border fixed group ($5.78 \mu\text{g}/\text{mg} \pm 0.02$) significantly ($P < 0.05$) different to the non ($3.75 \mu\text{g}/\text{mg} \pm 0.63$) and the bottom ($4.58 \mu\text{g}/\text{mg} \pm 0.26$) fixed group (Fig. 6).

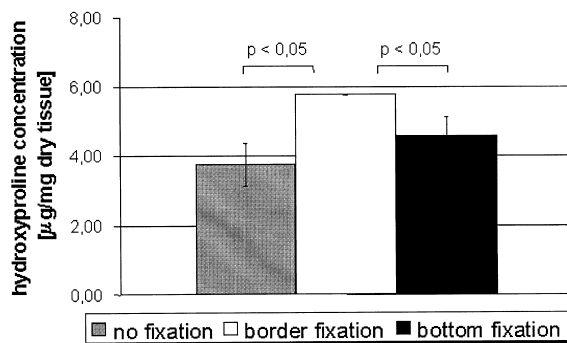

Fig. 6. Hydroxyproline concentration regard to the fixation method after a culturing period of 50 days.

4. Discussion

The aim of the study was the evaluation of fibrin gel as a scaffold for the production of 3-D cardiovascular structures like vessels or valve conduits. The tissue development in the gel showed excellent results up to a layer thickness of 3 mm. And therefore the formation of a complex structure with a different thickness in the vascular and the cusp part was successfully simulated in the simplified mold model.

In comparison to the most commonly used scaffolds, fibrin gel combines some important advantages. At first, the degradation of the scaffold is controllable and can be adapted to the tissue development. Fibrin as a natural polymer will be formed by the enzymatic polymerization of fibrinogen. We profit of the degradation and remodelling by cell-associated enzymatic activity and the regulation of this process by aprotinin, a protease inhibitor, which is able to stop the fibrinolysis via inhibiting plasmin completely or slow down the degradation of the gel in vitro.

Beyond it, fibrin gel can be produced from patients blood and therefore the risk of immunogenic reactions are improbable. The potential risks of, e.g. virus infections by the use of scaffolds based on homo- or xenografts are non-existent.

The cell distribution in the scaffold is an important factor for a strong tissue development. It is known, that the initially high homogenous cell distribution is associated with high rates of extracellular matrix production [11–13].

The distribution and attachment of cells in sponge structures (collagen, PUR sponges etc.) or fiber structures (PGA, PH4B etc.) are mainly determined by gravity [14]. Although the cell attachment of fiber structures can be improved by different precoating techniques, circa 30–40% of the initially seeded cells do not attach to the scaffold and get lost for a further tissue development [15,16]. The spatially uniform distribution is a function of the porosity and surface charge of the scaffold. In sponge scaffolds the highest concentration of the cells is observed on the surface of the tissue [17,18] and the cell migration into the scaffold take place afterwards. This results in a delayed tissue development.

In contrast, the distribution in the fibrin gel is homogenous from the beginning, caused by the fast immobilization of the cells during the polymerization of the gel/cell suspension within a few minutes.

Copolymers of lactic and glycolic acid especially PGA have the major disadvantage of a bulk degradation. We observed local, central cell necrosis in thicker PGA scaffolds after culturing period of 4 to 5 weeks, when the pH in the medium falls rapidly to low values by the degradation product lactic acid. Such phenomenon were not observed in the fibrin gel degradation and structures with a layer thickness up to 3 mm can be produced trouble-free.

The fibrin gel seems to be able to accumulate the newly synthesized collagen and other extracellular matrix components in the intercellular space. The diffusion and wash-out of this substances into the surrounding medium seems to be

reduced in the fibrin gel as a solid scaffold in comparison to porous matrices.

In vitro studies showed that fibrin gels produced from patients blood promote the matrix synthesis through the release of platelet-derived growth factors and the transforming growth factor beta [19].

The possibility to cross-link exogenous bifunctional peptides into fibrin gels with factor XIIIa allows the immobilization of different growth factors in specific areas of the engineered structure. Through this, the immobilization of, e.g. vascular growth factors in the aortic wall can promote the development of vasa vasorum locally and allows the construction of thicker tissues [20–23].

Fibrin gel as an ideal scaffold has two major disadvantages: The shrinking of the gel and the initial, low mechanical stiffness, which do not allow a direct implantation of the new formed structures.

Shrinking is a problem in the formation of flat sheets for the production of tissue engineered single cusps or pericardium. The problem can be solved by the fixation of the gel with poly-L-lysine during the culturing period. The technique of a border fixation obtains the best results relating to the collagen synthesis and tissue development. The inner tension in the gel as a product of the tendency of shrinking and the fixation seems to be a promoter of the collagen synthesis. Culturing under defined shear stress can increase the collagen synthesis additionally [24].

The low initial stability is the topic of our current investigations. The optimization of the fibrinogen concentration in relation to the cell concentration in the gel promise an increase of the mechanical properties. Another alternative is the combination of high porous biodegradable scaffolds (pore size >1 mm) with the fibrin gel as a cell carrier.

In conclusion, fibrin gel combines a number of important properties of an ideal scaffold. It can be produced as an complete autologous scaffold. The degradation is controllable and can be adjusted to the tissue development by the use of aprotinin and the integration of growth factors is possible. The formation of complex 3-D structures (e.g. aortic conduits) seems to be possible.

Further investigation has to be undertaken to improve the initial mechanical stability. In addition the development of a mold for the creation of a tricuspid valve conduit as well as the construction of a pulsatile bioreactor are the further topics for a successful heart valve development based on a fibrin gel scaffold.

Acknowledgements

The investigation and optimization of the fibrin gel as a scaffold in cardiovascular tissue engineering was possible by the excellent interdisciplinary co-operation with the group of J.A. Hubbell, Department of Materials and Institute of Biomedical Engineering of the Technical University Zurich, Mr K. Marquardt (REM) of the Department of

Surgery, University Hospital Zurich, and the group of Prof T. Bächli (TEM) of the “Elektronenmikroskopischen Zentrallaboratorium” of the University Zurich.

References

- [1] Shinoka T, Shum Tim D, Ma PX, Tanel RE, Isogai N, Langer R, Vacanti JP, Mayer Jr JE. Creation of viable pulmonary artery autografts through tissue engineering. *J Thorac Cardiovasc Surg* 1998;115:536–545.
- [2] Zund G, Breuer CK, Shinoka T, Ma PX, Langer R, Mayer JE, Vacanti JP. The in vitro construction of a tissue engineered bioprosthetic heart valve. *Eur J Cardio-thorac Surg* 1997;11:493–497.
- [3] Zund G, Hoerstrup SP, Schoeberlein A, Lachat M, Uhlschmid G, Vogt PR, Turina M. Tissue engineering: a new approach in cardiovascular surgery; seeding of human fibroblasts followed by human endothelial cells on resorbable mesh. *Eur J Cardio-Thorac Surg* 1998;13:160–164.
- [4] Chevallay B, Herbage D. Collagen based biomaterials as 3D scaffold for cell cultures: applications for tissue engineering and gene therapy. *Med Biol Eng Comput* 2000;38(2):211–218.
- [5] Freed LE, Vunjak Novakovic G, Biron RJ, Eagles DB, Lesnoy DC, Barlow SK, Langer R. Biodegradable polymer scaffolds for tissue engineering. *Biotechnol N Y* 1994;12:689–693.
- [6] Grande DA, Halberstadt C, Naughton G, Schwartz R, Manji R. Evaluation of matrix scaffolds for tissue engineering of articular cartilage grafts. *J Biomed Mater Res* 1997;34:211–220.
- [7] Bader A, Schilling T, Teebken OE, Brandes G, Herden T, Steinhoff G, Haverich A. Tissue engineering of heart valves - human endothelial cell seeding of detergent acellularized porcine valves. *Eur J Cardio-thorac Surg* 1998;14:279–284.
- [8] Ye Q, Zund G, Benedikt P, Jockenhoewel S, Hoerstrup SP, Sakiyama S, Hubbell JA, Turina M. Fibrin gel as a three dimensional matrix in cardiovascular tissue engineering. *Eur J Cardio-thorac Surg* 2000;17:587–591.
- [9] Hata R, Senoo H. L-ascorbic acid 2-phosphate stimulates collagen accumulation, cell proliferation, and formation of a three-dimensional tissue-like substance by skin fibroblasts. *J Cell Physiol* 1989;138:8–16.
- [10] Reddy GK, Enwemeka CS. A simplified method for the analysis of hydroxyproline in biological tissue. *Clin Biochem* 1996;225–229.
- [11] Vunjak Novakovic G, Obradovic B, Martin I, Bursac PM, Langer R, Freed LE. Dynamic cell seeding of polymer scaffolds for cartilage tissue engineering. *Biotechnol Prog* 1998;14:193–282.
- [12] Kim BS, Putnam AJ, Kulik TJ, Mooney DJ. Optimizing seeding and culture methods to engineer smooth muscle tissue on biodegradable polymer matrices. *Biotechnol Bioeng* 1998;57:46–54.
- [13] Vunjak-Novakovic G, Freed LE, Biron RJ, Langer R. Effects of mixing on the composition and morphology of tissue-engineered cartilage. *Biotechnol Prog* 1998;14(2):193–202.
- [14] Sittinger M, Bujia J, Rotter N, Minuth WW, Burmester GR. Tissue engineering and autologous transplant formation: practical approaches with resorbable biomaterials and new culture techniques. *Biomaterials* 1996;17:237–242.
- [15] Zund G, Ye Q, Hoerstrup SP, Schoeberlein A, Schmid AC, Grunfelder J, Vogt PR, Turina M. Tissue engineering in cardiovascular surgery: MTT, a rapid and reliable quantitative method to assess the optimal human cell seeding on polymeric meshes. *Eur J Cardio-thorac Surg* 1999;15:519–524.
- [16] Ye Q, Zund G, Jockenhoewel S, Schoeberlein A, Simon P, Hoerstrup J, Grunfelder PB, Turina M. Scaffold precoating with human autologous extracellular matrix for improved cell attachment in cardiovascular tissue engineering. *ASAIO J* 2000;46(6):730–733.
- [17] Sodian R, Sperling JS, Martin DP, Egozy A, Stock U, Mayer Jr J, Vacanti JP. Fabrication of a trileaflet heart valve scaffold from a

- polyhydroxyalkanoate biopolyester for use in tissue engineering. *Tissue Eng* 2000;6(2):183–188.
- [18] Jockenhoevel S, Zund G, Dong N, Hoerstrup SP, Schmid A, Schmutz P, Turina M. Tissue engineering: evaluation of different biodegradable scaffolds. *ASAIO J* 2000;46(2):237.
- [19] Sierra D, Saltz R. *Surgical adhesives and sealants: current technology and application*. Lancaster, PA: Technomic Publishing Company, 1996.
- [20] Lewis KB, Teller DC, Fry J, Lasser GW, Bishop PD. Crosslinking kinetics of the human transglutaminase, factor XIII[A2], acting on fibrin gels and chain peptides. *Biochemistry* 1997;36:995–1001.
- [21] Hubbell JA. Bioactive biomaterials. *Curr Opin Biotechnol* 1999;10:123–129.
- [22] Hubbell JA. Biomaterials in tissue engineering. *Biotechnology N Y* 1995;13:565–576.
- [23] Schense JC, Hubbell JA. Cross-linking exogenous bifunctional peptides into fibrin gels with factor XIIIa. *Bioconjugate Chem* 1999;10:75–81.
- [24] Jockenhoevel S, Zund G, Hoerstrup SP, Schmid A, Schnell A, Turina M. Cardiovascular tissue engineering: a new laminar flow chamber for in vitro improvement of mechanical tissue properties. *ASAIO J* 2000;46(2):237.