REVIEW

The *Drosophila* Larva as a Model for Studying Chemosensation and Chemosensory Learning: A Review

Bertram Gerber¹ and Reinhard F. Stocker²

¹Universität Würzburg, Biozentrum, Am Hubland, Lehrstuhl für Genetik und Neurobiologie, D-97074 Würzburg, Germany and ²University of Fribourg, Department of Biology, 10, chemin du Musée, CH-1700 Fribourg, Switzerland

Correspondence to be sent to either author: Bertram Gerber, e-mail: bertram.gerber@biozentrum.uni-wuerzburg.de; Reinhard F. Stocker, e-mail: reinhard.stocker@unifr.ch

Abstract

Understanding the relationship between brain and behavior is the fundamental challenge in neuroscience. We focus on chemosensation and chemosensory learning in larval *Drosophila* and review what is known about its molecular and cellular bases. Detailed analyses suggest that the larval olfactory system, albeit much reduced in cell number, shares the basic architecture, both in terms of receptor gene expression and neuronal circuitry, of its adult counterpart as well as of mammals. With respect to the gustatory system, less is known in particular with respect to processing of gustatory information in the central nervous system, leaving generalizations premature. On the behavioral level, a learning paradigm for the association of odors with food reinforcement has been introduced. Capitalizing on the knowledge of the chemosensory pathways, we review the first steps to reveal the genetic and cellular bases of olfactory learning in larval *Drosophila*. We argue that the simplicity of the larval chemosensory system, combined with the experimental accessibility of *Drosophila* on the genetic, electrophysiological, cellular, and behavioral level, makes this system suitable for an integrated understanding of chemosensation and chemosensory learning.

Key words: *Drosophila*, larva, learning, olfaction, taste

Smell and taste systems

Chemosensory systems serve animals to cope with their chemical environment; this may sound trivial but has a rather different thrust than suggesting that chemosensory systems need to faithfully reflect the outside world. To be sure, neuronal activity along the chemosensory pathways must allow the animal to tell apart different chemicals—but only insofar as may be required to differentially behave toward them. Thus, depending on the behavioral demands, different inputs may or may not lead to different activity patterns in the chemosensory pathways; in turn, however, differences in activity pattern need to reflect differences in input. In other words, the discriminative demands stem from the potential behavioral matters of concern, not from the diversity of inputs: what is at issue is whether different chemicals should make a behavioral difference to the animal. Interestingly, sensory modalities, and in particular olfaction and taste, can differ tremendously in terms of this required discriminative ability.

This review focuses in its first part on chemosensory processing and asks how discriminative patterns of neuronal ac-

tivity come about in chemosensory pathways. In the second part, it discusses whether and how odors can be recognized as the same as those odors that had been previously encountered. Given the diversity of chemicals involved, given the combinatorial possibilities with which these chemicals can occur in nature, and given the temporal variability of the chemical environment, understanding how these tasks can be managed is a real challenge. A breakthrough was achieved upon the identification of odorant receptor genes in rodents (Buck and Axel 1991) and some years later in *Caenorhabditis elegans* (Sengupta et al. 1996) and *Drosophila* (Clyne et al. 1999; Vosshall et al. 1999). Their expression patterns in particular are useful for dissecting the circuits underlying olfaction (Ressler et al. 1994; Vassar et al. 1994; Gao et al. 2000; Vosshall et al. 2000). Remarkably, these studies confirm earlier convictions that the olfactory systems of mammals and insects are organized according to common principles (Hildebrand and Shepherd 1997; Strausfeld and Hildebrand 1999; Ache and Young 2005). Yet, insect chemosensory

systems comprise only a fraction of the cell numbers involved in the vertebrate systems, providing an attractively simple option for investigating the chemical senses. What is more, in holometabolous insects, such as *Drosophila*, the larval chemosensory system offers an even simpler alternative. Apart from a study in larval *Manduca sexta* (Itagaki and Hildebrand 1990), little was known until recently about the organization of larval olfactory systems. Adults and larvae are anatomically and behaviorally much different, reflecting their different lifestyles. For example, adult *Drosophila* flies need to find food (as well as mates, egg-laying sites, etc.), which requires sophisticated odor-driven behavior. Fly larvae, in contrast, live on their food source and hence do not need long-range odor detection to find food. Although larvae respond to a variety of chemicals (Rodrigues 1980; Cobb 1999; Heimbeck et al. 1999; Cobb and Domain 2000), one may expect the chemosensory systems of both developmental stages to display significant differences in terms of cell number, organization, and behavioral function.

A number of recent papers promote the larval olfactory system of *Drosophila* as a “elementary” model system (Fishilevich et al. 2005; Kreher et al. 2005; Masuda-Nakagawa et al. 2005; Melcher and Pankratz 2005; Michels et al. 2005; Ramaekers et al. 2005) rendering a review on larval chemosensation timely.

Sensory level

Cephalic chemosensory organs

The cephalic chemosensory apparatus of the larva includes 3 external sense organs, dorsal organ (DO), terminal organ (TO), and ventral organ (VO), as well as 3 internal, pharyngeal organs (Figure 1C–H) (Singh RN and Singh K 1984; Singh 1997; Python and Stocker 2002a; Gendre et al. 2004). Each of them consists of several sensilla, a sensillum comprising one to several sensory neurons and 3 accessory cells, all housed below a common cuticular structure or terminal pore.

The DO is composed of the central “dome” (Figure 1E) and 6 peripheral sensilla. The dome, whose wall is perforated by thousands of pore tubules, is innervated by the profuse dendritic arbors of 21 olfactory receptor neurons (ORNs). An olfactory function of the dome is demonstrated by electrophysiological recordings (Oppliger et al. 2000; Kreher et al. 2005) and by combined toxin expression and behavioral studies (Heimbeck et al. 1999; Larsson et al. 2004; Fishilevich et al. 2005). Indeed, by expressing diphtheria toxin or by genetically ablating the atypical odorant receptor OR83b that is required for normal ORN function in the 21 sensory neurons of the dome, both latter studies demonstrate that these neurons are the sole larval ORNs. In *Musca*, 5 of the 6 peripheral sensilla of the DO, most of the TO sensilla and 1 of the 4 VO sensilla are thought to be taste sensilla (Chu and Axtell 1971; Chu-Wang and Axtell 1972a, 1972b). TO sensilla belong to at least 6 different types, collected in a distal

group of 11 sensilla and a dorsolateral group of 2 sensilla that are discernable from the outside (chevrons in Figure 1F), and, in analogy to the situation in *Musca* (Chu-Wang and Axtell 1972a), likely a third one that is not. Thus, the DO is a mixed smell and taste organ, whereas the TO, the VO, and the pharyngeal sensilla serve gustatory function. However, apart from chemosensory neurons, thermosensory (Liu, Yermolaieva, et al. 2003), mechanosensory, or hygro-sensory neurons may be present.

The DO, TO, and VO all have their proper ganglion (Figure 1C,G). The ganglion of the DO contains 36–37 sensory neurons (Python and Stocker 2002a). The 21 ORNs among them extend their dendrites as 7 triplets into the dome. The dendrites of 3 other neurons project toward the dorsolateral sensilla of the TO (Kankel et al. 1980; Frederik and Denell 1982; Heimbeck et al. 1999; Python and Stocker 2002a), whereas the remaining cells innervate the 6 peripheral sensilla of the DO. The TO and VO ganglia include 32 and 7 sensory neurons, respectively (Python and Stocker 2002a).

The 3 pharyngeal sense organs consist of several sensilla each, comprising 1–9 sensory neurons (Singh RN and Singh K 1984; Python and Stocker 2002a; Gendre et al. 2004). Gustatory and mechanosensory function is suggested by the presence of pores or bristles, respectively. The dorsal and ventral pharyngeal sense organs, both of which are situated behind the mouth hooks, contain 17 and 16 neurons, respectively; the posterior pharyngeal sense organ consists of 2 sensilla with 3 neurons each (Figures 1C and 3).

As in adult flies, central olfactory projections remain supraesophageal and are collected in the antennal lobe (AL), whereas taste information is sent to multiple target areas in the subesophageal ganglion (SOG [Figure 1C], which do not show any obvious glomerulus-like organization). Different from adults, however, all olfactory projections remain ipsilateral. Neurons from the DO ganglion, regardless of their olfactory or gustatory nature and regardless of whether their dendritic tips extend to the DO or TO, connect to the brain via the antennal nerve (Tissot et al. 1997; Python and Stocker 2002a) (Figure 1C,I). The supraesophageal labral nerve carries the afferents from the dorsal pharyngeal organ and probably from the posterior pharyngeal organ, whereas the subesophageal maxillary and labial nerves comprise those from the TO and VO ganglia and from the ventral pharyngeal organ, respectively (cf., Schmidt-Ott et al. 1994; Campos-Ortega and Hartenstein 1997; Python and Stocker 2002a; Gendre et al. 2004) (Figure 1C).

Expression of olfactory receptors

Olfactory receptors (ORs) define the range of detectable odors. The OR expression pattern across the population of ORNs provides the basis for a combinatorial activation in their target areas, which allows the animal to discriminate a practically unlimited number of different odors (for mammals: Buck and Axel 1991; Ressler et al. 1994; Vassar et al.

1994; for fruitflies: Clyne et al. 1999; Vosshall et al. 1999, 2000; Gao et al. 2000).

In adult *Drosophila*, 2 subfamilies of 7-transmembrane chemosensory receptors are known, an OR family comprising 62 members (Clyne et al. 1999; Vosshall et al. 1999; Robertson et al. 2003; Hallem et al. 2006) and a family of gustatory receptors (GRs) with 60 members (Clyne et al. 2000; Dunipace et al. 2001; Scott et al. 2001; Robertson et al. 2003; Hallem et al. 2006). Similar to mammalian ORNs, ORNs of the adult fly typically express only a single “conventional” OR that is responsible for the ligand specificity of the ORN (Clyne et al. 1999; Vosshall et al. 1999; Dobritsa et al. 2003; Hallem et al. 2004; Goldman et al. 2005). For a substantial subset of these ORs, odorant response spectra as well as their expression in identified types of ORNs are reported (Dobritsa et al. 2003; Hallem et al. 2004). ORNs expressing a given OR converge onto 1 or 2 glomeruli in the AL (Gao et al. 2000; Vosshall et al. 2000; Bhalerao et al. 2003), a layout that is shared with the mammalian olfactory system. Thus, the chemical information conveyed by ORNs is translated into a pattern of glomerular activation (Fiala et al. 2002; Ng et al. 2002; Wang et al. 2003; Yu et al. 2004). Apart from the conventional ORs, one atypical OR, OR83b, is expressed in 70–80% of the antennal ORNs; it appears to be involved in proper localization and function of conventional ORs but does not seem to influence ligand specificity (Larsson et al. 2004; Neuhaus et al. 2004; Benton et al. 2005).

Three recent studies (Larsson et al. 2004; Fishilevich et al. 2005; Kreher et al. 2005) demonstrate that the logic of *Or* gene expression in the larval olfactory system, despite its simplicity, is surprisingly similar to the adult and mammalian design. For 25 *Or* genes, expression is shown in the DO both by RNA in situ hybridization and by *Or-Gal4* transgene expression (Fishilevich et al. 2005). Evidence for a few additional larval *Or* gene candidates derives from reverse transcriptase–polymerase chain reaction amplification or from *Or-Gal4* driver analysis (Couto et al. 2005; Fishilevich et al. 2005; Kreher et al. 2005). Each of the 21 larval ORNs expresses the atypical receptor gene *Or83b* (Larsson et al. 2004). The large majority of the neurons appear to express one conventional OR along with OR83b, whereas 2 ORNs were shown to express 2 conventional ORs together with OR83b (Fishilevich et al. 2005). Interestingly, of the 25 well characterized larval *Or* genes, 13 are larval specific (*Or1a*, *Or22c*, *Or24a*, *Or30a*, *Or45a*, *Or45b*, *Or59a*, *Or63a*, *Or74a*, *Or83a*, *Or85c*, *Or94a*, *Or94b*) (Fishilevich et al. 2005; Kreher et al. 2005), whereas the remaining 12 *Or* genes are expressed in adults as well (*Or2a*, *Or7a*, *Or13a*, *Or33a*, *Or33b*, *Or35a*, *Or42a*, *Or42b*, *Or47a*, *Or67b*, *Or82a*, *Or83b*) (Clyne et al. 1999; Vosshall et al. 1999, 2000; Robertson et al. 2003; Komiyama et al. 2004). Coexpression of 2 ORs in one ORN refers to the gene pairs *Or33b/Or47a* and *Or94a/Or94b*. Because the number of identified ORs exceeds the total number of ORNs, a few more cases of triple

OR expression are to be expected; indeed, many combinations of different *Or* genes are not tested to date.

Using a strategy based on the expression of single *Or* genes in adult dysfunctional mutant ORNs, that is, the “empty neuron approach” (Dobritsa et al. 2003; Hallem et al. 2004; Goldman et al. 2005), the odor response spectra of 11 larval ORs were studied by testing electrophysiological responses to a panel of 29 odorants (Kreher et al. 2005). These odors, that include different chemical classes, are known as adult or larval stimulants (Monte et al. 1989; Cobb 1999; Heimbeck et al. 1999; Hallem et al. 2004; Goldman et al. 2005). The response spectra of these ORs are very diverse, ranging from OR94b that responds to a single tested odorant, 4-methylphenol, to OR42a and OR85c each responding to 9 odorants (Kreher et al. 2005). Odorants that elicit strong responses usually do so in multiple receptors. Some receptors respond most strongly to aliphatic compounds (OR42a, OR74a, OR85c), whereas others seem to be tuned to aromatic compounds (OR30a, OR45b, OR59a, OR94b). Most of the recorded responses are excitatory, but some receptors are strongly inhibited by one compound and excited by another. Finally, response dynamics and odor sensitivities vary largely among different receptors. Yet, it should again be noted that these data are obtained by recording from “empty” adult antennal ORNs in which the larval *Or* genes were ectopically expressed.

Expression of gustatory receptors

The gustatory system appears to have a lower dimensionality than olfaction. In the mouse, for example, receptor cells expressing specific heterodimer combinations of the taste receptor family T1R are tuned to sugars or amino acids (Montmayeur and Matsunami 2002), but the diversity of these compounds compared with the spectrum of odorants is probably much smaller. The much larger T2R family, responsible for detecting bitter compounds, is expressed in other cells. Each of them expresses multiple T2Rs, suggesting that its capacity to distinguish between different bitter substances is limited (Montmayeur and Matsunami 2002). Thus, in comparison with the discrimination-optimized olfactory system, the taste system seems to be designed to classify the substances involved into a handful of behavioral matters of concern, for example, “nonedible” versus “edible”; this is in accordance with the much closer association of gustatory sensory neurons with motor centers. This association with motor centers may correspondingly explain the apparent lack of a specific, unified first-order gustatory neuropil that could integrate all gustatory input; this, again, is striking when compared with the role of the AL in olfaction. In short, smell may be for discrimination—to potentially be linked to many kinds of behavior—whereas taste may be for classification that already is hooked up to rather specific behaviors.

In adult *Drosophila*, the available evidence suggests that the GR family mediates both sweet and bitter responses.

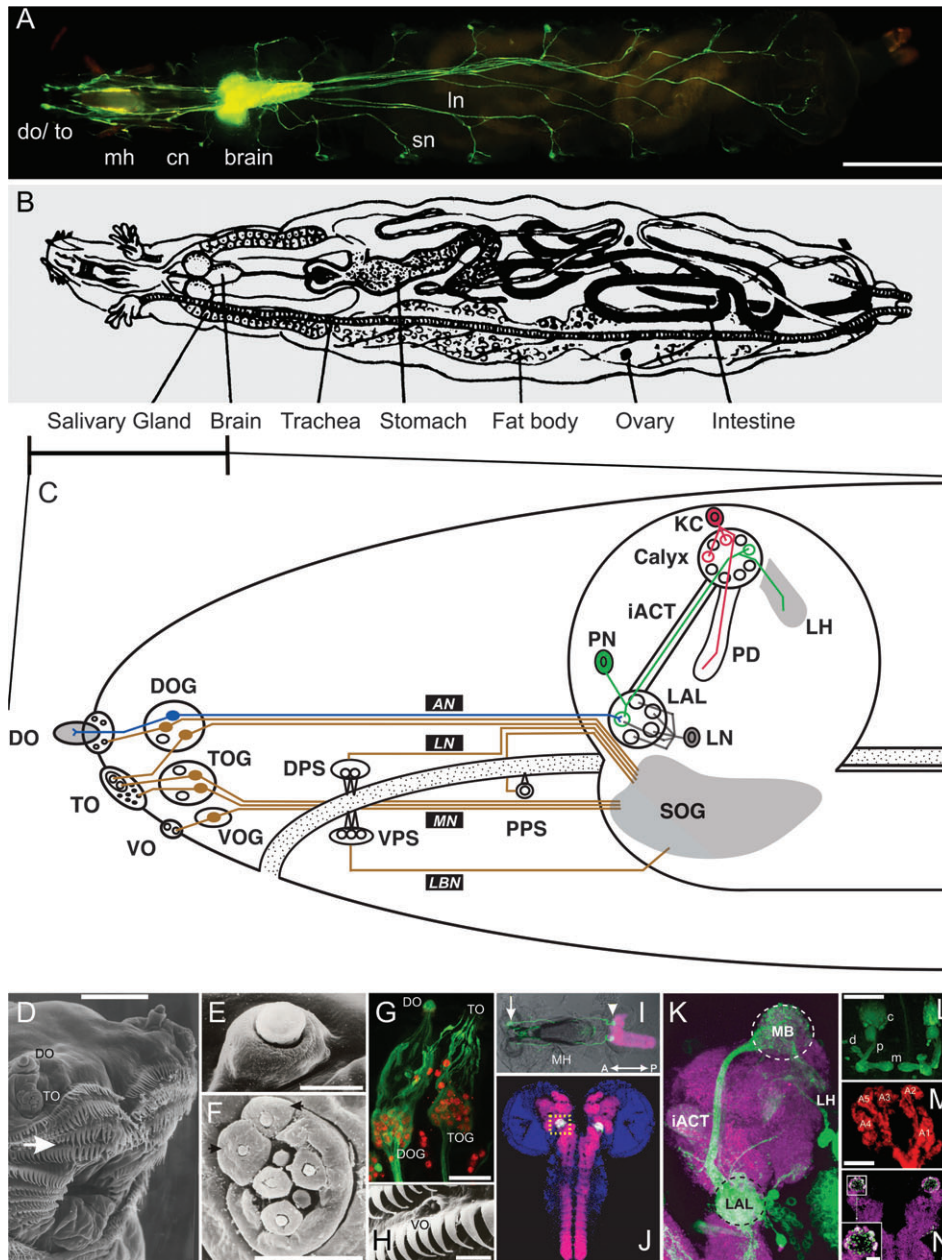

Figure 1 Overview of larval anatomy and cephalic chemosensory pathways. **(A)** Overview of structures in the third instar larval nervous system. One can distinguish the DO/TO complex (do, to), the autofluorescent mouth hooks (mh), the cephalic nerves (cn), the central nervous system comprising both brain hemispheres and the cone-shaped ventral nerve cord, as well as segmental and longitudinal nerves (sn, ln). Scale bar 200 μm . **(B)** Semischematic overview of general larval anatomy. **(C)** Schematic overview of the cephalic chemosensory pathways. From the 3 external chemosensory organs, the DO is a mixed structure composed of the central olfactory dome (gray) and a few putative taste sensilla (small circles). The TO with its dorsolateral and distal division (oval and small circles, respectively), the VO, as well as the dorsal, ventral, and posterior pharyngeal sense organs (DPS, VPS, PPS) include mainly gustatory sensilla. The cell bodies of the sensory neurons are collected in ganglia below each sense organ (DOG, TOG, VOG). Some of the neurons innervating the dorsolateral sensilla of the TO are situated in the ganglion of the DO. Odorant receptor neurons (blue) send their axon via the antennal nerve (AN) into the LAL. Local interneurons (LN) interconnect the glomeruli of the LAL. PNs (PN; green) travel in the inner antennocerebral tract (iACT) to link the LAL with the MB calyx and the lateral horn (LH). An intrinsic MB Kenyon cell (KC) extending its process via the pedunculus (PD) into the MB lobes (not indicated) is shown in red. Axons from putative taste receptor neurons (brown) extend via the AN, the labral nerve (LN), the maxillary nerve (MN), and the labial nerve (LBN) to the subesophageal target region (SOG). The connectivity toward motor neurons is unknown, but concerning taste likely originates from the SOG and concerning olfaction likely from the LH and/or the MB lobes. The pharynx is shown stippled. **(D)** Scanning electron micrograph showing the topology of the external chemosensory organs on the larval head. DO and TO are visible, the VO is hidden behind the cirri above the mouth (arrow) (see H). Scale bar 50 μm . **(E)** Scanning electron micrograph of the DO showing the central dome and the surrounding wall. Scale bar 10 μm . **(F)** Scanning electron micrograph of the TO comprising a smaller dorsolateral group of sensilla (arrows) and a larger distal group of sensilla. Scale bar 20 μm . **(G)** Cellular anatomy of DO and TO and their ganglia (DOG, TOG). Neuronal nuclei are shown in red. Scale bar 25 μm . **(H)** Scanning electron micrograph of the VO (see D for topology). Scale bar 10 μm . **(I)** Projection of ORNs from the DO (arrow) past the mouth hooks (MHs) toward the

The expression pattern of the members of this family in the adult was studied exclusively by *Gr* gene promoter-*Gal4* analysis (Dunipace et al. 2001; Scott et al. 2001) due to low levels of *Gr* gene expression. Whether the observed reporter patterns faithfully reflect *Gr* expression remains to be shown. Similar to mammals, neurons responding to sugars (the best studied example being *Gr5a*, expressed in cells that respond to trehalose [Chyb et al. 2003]) and neurons responding to “bitter” substances express different sets of *Gr* genes (Thorne et al. 2004; Wang, Singhvi, et al. 2004). This design allows eliciting attractive or aversive behaviors, respectively. Surprisingly, 3 GRs are expressed in neurons of the antenna, suggesting that smell and taste functions may not strictly be associated with OR/GR family membership, respectively (Scott et al. 2001). One among these *Gr* genes, *Gr21a*, is expressed in CO₂-sensitive cells of the antenna that are necessary for behavioral responses of the flies to CO₂ (Suh et al. 2004).

Gal4 expression driven by *Gr* gene promoters is also used in the larva (Scott et al. 2001; Fishilevich et al. 2005; Colomb et al., in preparation), but so far data are relatively scarce. *Gr2a*, *Gr21a*, *Gr22e*, *Gr28be*, *Gr32a*, and *Gr66a*, all of which drive expression also in the adult, are expressed in neurons of the TO. *Gr2a* labels in addition 2 neurons in the DO that are nonolfactory. GR22e, GR28be, GR32a, and GR66a are suspected to represent “bitter” receptors in the adult, as they are coexpressed in many neurons (Thorne et al. 2004; Wang, Singhvi, et al. 2004). However, when studying *Gal4* driver lines, no coexpression was observed in the larva between *Gr66a* on the one hand and *Gr2a*, *Gr21a*, *Gr32a*, and *Gr59f* on the other (Scott et al. 2001, Colomb J, Grillenzoni N, Ramaekers A, Stocker RF, in preparation). Yet, drawing general conclusions about the numbers of GRs expressed by individual neurons seems premature. Finally, it is worth mentioning that *Gr21a*, which in adults is expressed in CO₂-responsive cells, is expressed in the TO in cells necessary for the behavioral response of the larvae to CO₂ (Faucher et al. 2006) and that several members of the *Or* gene family (*Or30a*, *Or42a*, *Or49a*, *Or63a*) seem to be expressed in both DO and TO (Scott et al. 2001; Fishilevich et al. 2005; Kreher et al. 2005). Thus, as in adults, gene family membership, involvement in processing of airborne versus nonairborne chemicals and site of expression are not strictly linked, reflecting the notion that *Gr* and *Or* genes belong to a single large superfamily (Scott et al. 2001; Robertson et al. 2003).

Salt detection is not mediated by GRs but by degenerin/epithelial Na⁺ channels, which are expressed in the TO as

well as in adult taste bristles (Liu, Leonard, et al. 2003, Colomb et al., in preparation).

Smell and taste centers

A glomerular map in the AL

The architecture of the larval olfactory pathway is surprisingly similar to its adult counterpart and to the situation in mammals, but much simpler. Olfactory afferents terminate in the larval antennal lobe (LAL) (Figure 1I,J,M) targeting 2 types of interneurons: local interneurons, which establish lateral connections in the LAL, and projection neurons (PNs) that connect the LAL with higher order olfactory centers, the mushroom body (MB) calyx and the lateral horn (Figures 1C,K,L,N and 2) (Python and Stocker 2002a; Marin et al. 2005). As in the adult fly, immunoreactivity against choline acetyl transferase (ChAT) suggests that ORNs and PNs are cholinergic. In contrast, most or even all local interneurons express γ -aminobutyric acid (GABA) (Python and Stocker 2002b), indicating that, as in adults, they probably have inhibitory effects.

The expression patterns of ORN-specific and PN-specific *Gal4* driver lines reveal the presence of glomerulus-like subregions in the LAL (Python and Stocker 2002a). To study whether the terminals of individual ORNs target a single glomerulus or extend throughout the entire LAL, the flipase-out technique (FLP-out; Wong et al. 2002) was applied in the ORN-specific *Or83b-Gal4* line (Ng et al. 2002; Larsson et al. 2004). This allows visualizing individual ORNs in the background of the remaining, differently labeled ORNs (Ramaekers et al. 2005). Clearly, each ORN projects to a single LAL glomerulus (Figure 2). Because in all the 84 studied cases, FLP-out and background labels were mutually exclusive, any given glomerulus must be the target of only a single ORN. Hence, each of the 21 ORNs is unique in projecting to its one and only glomerulus; thus, the “odor space” of the larva has 21 dimensions, as defined by the number of functional types of ORNs and LAL glomeruli. As in the adult AL (Laissue et al. 1999), the relative size, shape, and position of individual glomeruli are quite conserved, allowing the establishment of a glomerular terminology in the LAL (Ramaekers et al. 2005) (Figure 1M).

In parallel studies, Fishilevich et al. (2005) and Kreher et al. (2005) report the central projections of ORNs expressing a given “conventional” OR, using *Gal4* transgene expression under the control of the *Or* gene promoters. For each of the 22 ORs studied, the corresponding axon terminals target a

LAL (arrowhead). **(J)** Location of the LAL within the brain. **(K)** PNs extending from the LAL via the iACT to the MB calyx and the LH. **(L)** MBs with calyces (c), peduncle (p), and medial as well as dorsal lobes (m, d). Scale bar 50 μ m. **(M)** LAL with some identified glomeruli (A1–A5). Scale bar 5 μ m. **(N)** Location of the MB calyces within the brain, and close-up revealing the glomerular organization of the MB calyx (inset). Scale bars 10 μ m. Images taken from Sun et al. (1999) (A), Demerec and Kaufmann (1972) (B), Stocker (forthcoming) (C), Scherer et al. (2003) (E, F), Python and Stocker (2002a) (G, L), Gerber et al. (2004) (H), Fishilevich et al. (2005) (I, J), Marin et al. (2005) (K), and Ramaekers et al. (2005) (M, N); please refer to these publications concerning genotypes and methods used. The following copyright holders kindly granted permission to use these figures: The National Academy of Sciences, USA (A), The Carnegie Institution (B), Landes Bioscience (C), Kirsas Neuser (D), Cold Spring Harbour Laboratory Press (E, F), John Wiley & Sons, Inc. (G, L), The Company of Biologists (H, K), Elsevier (I, J, M, N).

different glomerulus, except of course for OR33b and OR47a, that are coexpressed in a common ORN and which thus target a common glomerulus (the ORN coexpressing the *Or94a/Or94b* combination of genes was not studied with respect to its axon terminals). Moreover, in 42 cases using 2 *Or-Gal4* driver constructs in the same animal, 2 labeled ORNs were found, each projecting to its genuine glomerulus. This confirms that indeed each of the ORNs has its one and only proper glomerulus. Having identified ligands for some of the ORs, a preliminary spatial map of odor representation in the LAL could be established (Kreher et al. 2005). Accordingly, target glomeruli of receptors tuned to aliphatic compounds and target glomeruli of receptors tuned to aromatic compounds appear to cluster at distinct sites of the LAL.

Are these glomeruli recognized also by the dendritic arbors of PNs? PNs in third instar larvae belong to 2 classes, that is, immature, adult-specific PNs with incomplete dendrites and axons (Jefferis et al. 2004) and mature larval PNs (Marin et al. 2005). As in adults, the latter establish dendritic arbors in the LAL and send their axons through the inner antennocerebral tract into the MB calyx and the lateral horn (Figures 1C,K,L and 2) (Python and Stocker 2002a). Using the same 2-label strategy as explained above for the ORNs, but in the PN-specific *GHI46-Gal4* driver (Stocker et al. 1997), the dendrites of these mature PNs were found to be restricted to single LAL glomeruli (Ramaekers et al. 2005). Using the technique of mosaic analysis with a repressible cell marker (MARCM) (Lee and Luo 1999), a minority of PNs were found to be biglomerular (Marin et al. 2005). Because in each of the 100 analyzed PN FLP-out cases, the FLP-out and background labels were mutually exclusive, each glomerulus seems to be innervated by a single *GHI46-Gal4*-positive PN only (Ramaekers et al. 2005). The glomeruli recognized by PNs correspond to the ones identified on the basis of the ORN terminals, indicating that the glomeruli of the LAL meet the wiring criteria of typical insect glomeruli, that is, an overlap of ORN terminals and dendritic PN arbors (Figures 1M and 2). Even though the 16–18 larval PNs labeled by *GHI46* may not comprise all PNs, the total PN number may not be much higher than the number of LAL glomeruli.

Finally, shown by single-cell FLP-out labelings with the *c739-Gal4* driver, the arborizations of at least one type of local interneurons cover the entire LAL, similar to the common type of adult local interneurons (Ramaekers et al. 2005).

A glomerular map also in the MB calyx

How do the axons of PNs convey the activation pattern of the LAL glomeruli to higher brain centers, such as the MB calyx? The adult calyx is composed of hundreds of glomeruli (Yasuyama et al. 2002). Adult PNs establish 1–11 terminal boutons in variable calyx regions (Wong et al. 2002), each bouton probably corresponding to a single glomerulus (Yasuyama et al. 2002). In contrast, the larval MB calyx consists of a small number of well-defined, relatively large glomeruli (Figure 1N) (Marin et al. 2005). Two parallel

approaches provide glomerular maps of the calyx. By expressing the reporter green fluorescent protein under the control of the MB-specific line OK107, Masuda-Nakagawa et al. (2005) identify 34 stereotypic calyx glomeruli. Based on strong ChAT immunoreactivity—which is very likely located in the terminals of PNs—Ramaekers et al. (2005) identify 28 calyx glomeruli from a somewhat larger total. Eighteen to 23 glomeruli are found to be targets of *GHI46*-positive PNs (Masuda-Nakagawa et al. 2005; Ramaekers et al. 2005), and 23 glomeruli are found to be targets of another PN-specific driver line, NP225 (Masuda-Nakagawa et al. 2005). Fine structural data suggest that each calyx glomerulus is occupied by a swollen, bouton-like terminal of a single PN (Marin et al. 2005). Most of the PNs choose single calyx glomeruli as targets, but in a minority of cases, PNs establish terminals in 2 calyx glomeruli (Marin et al. 2005; Masuda-Nakagawa et al. 2005; Ramaekers et al. 2005). Again, calyx glomeruli seem to be innervated by single *GHI46*-positive PNs (Ramaekers et al. 2005).

A comparison of the input and output sites of PNs so far reveals 7 types of PNs, which stereotypically connect a specific LAL glomerulus with a specific calyx glomerulus (Ramaekers et al. 2005). Thus, the combinatorial activity pattern set up in LAL glomeruli, which is a result of ORN input and modulation by local interneurons, seems to be rather faithfully conveyed to the calyx. Whether such strict input–output correlations apply to all PNs remains to be shown. In adults, the terminals of PNs establish stereotypical patterns in the lateral horn (Marin et al. 2002; Wong et al. 2002; Tanaka et al. 2004), whereas in the MB calyx, only concentric target zones can be defined for PNs deriving from specific AL glomeruli (Tanaka et al. 2004). Clearly, the straightforward connectivity of larval PNs seems well suited for analyzing calyx function.

Single-cell clones produced in MB-expressing *Gal4* lines by FLP-out and MARCM methods (Lee et al. 1999) (for a discussion of these methods, see supplement of Ramaekers et al. 2005), allow classifying MB neurons according to their dendritic connectivity in the calyx. MB neurons differ with respect to the number of calyx glomeruli they innervate: embryonic-born MB γ neurons typically establish dendritic projections in 1 or 2–3 calyx glomeruli (Ramaekers et al. 2005); larval-born MB neurons, however, may have either one (Ramaekers et al. 2005) or multiple dendritic termini in usually 6 glomeruli (Masuda-Nakagawa et al. 2005). Depending on larval stage, it may therefore be that both types of neurons contribute to MB function. In any event, the populations of single-cell clones generated from *Gal4* lines labeling subsets of MB neurons do not reveal any preferential innervation of particular glomeruli by these subsets of MB neurons (Masuda-Nakagawa et al. 2005). Thus, in principle, the MB neurons marked in a given *Gal4* line receive the complete PN-mediated olfactory representation. Interestingly, MB neurons from different MB-expressing *Gal4* lines seem to supply different regions of the peduncle and lobes

(Kurusu et al. 2002), suggesting that genetically defined subsets of MB neurons, although drawing upon the same calycol input, are multiplexed in terms of their output. From a developmental perspective, however, the progeny deriving from each of the 4 MB neuroblasts appears to have a loosely defined preference to target-specific subsets of calyx glomeruli (Masuda-Nakagawa et al. 2005) and would thus each receive slightly different facets of the PN-mediated olfactory information. In any event, the hardly more than 21 larval PNs are confronted with an estimated 600 functional MB γ neurons, functionality being assumed by the presence of dendritic arborizations (Lee et al. 1999; L Luo, personal communication; for an estimation of a total of 1800 MB neurons in the late third larval instar, based on fiber counts in electron micrograph sections, see Technau and Heisenberg 1982). Hence, the larval calyx, like its adult homologue, is a site of divergence: One can estimate that each PN connects to 30–180 MB γ neurons. That is, if all MB γ neurons were uniglomerular, the chance for any of the 600 MB γ neurons to connect to any of the approximately 20 PNs is $1/20 \times 1/600$. As any given PN has 600 such “chances” because there are 600 MB γ neurons, it should connect to $600 \times 1/20 \times 1/600 = 1/20$ of all MB γ neurons, that is, 30 neurons. If all MB γ neurons were multiglomerular and connecting to 6 glomeruli, the chance for any of the 600 MB γ neurons to connect to any of the approximately 20 PNs is $1/20 \times 1/600 \times 6$. As any given PN has 600 such “chances,” it should connect to $600 \times 1/20 \times 1/600 \times 6 = 3/10$ of all MB γ neurons, that is, 180 neurons. By the same token, considering all MB neurons (1800: Technau and Heisenberg 1982), divergence from PNs to MB neurons would be ranging between 1:90 and 1:420. Obviously, these estimates of divergence differ by an order of magnitude (minimum 1:30, maximum 1:420), suggesting that more quantitative studies on the development, number, functionality, and dendritic connectivity of larval MB neurons are needed. Finally, one must not forget that to the extent that MB neurons receive input from more than one PN, these MB neurons are a point of convergence (Perez-Orive et al. 2002).

The larval olfactory circuit: functional implications

As discussed above, larval ORNs express only 1 or 2 conventional *Or* genes along with the atypical *Or83b* (Larsson et al. 2004; Fishilevich et al. 2005; Kreher et al. 2005). This is similar to adult flies and to mammals but differs from *C. elegans*, in which ORNs express multiple ORs (Troemel et al. 1995). By using “subtractive” and “additive” ORN strategies, possible rules of olfactory coding were investigated in chemotaxis assays (Fishilevich et al. 2005). In the subtractive strategy, selected ORNs are genetically ablated via toxin expression, whereas in the additive strategy, animals are created with only 1 or 2 pairs of functional ORNs.

In the subtractive approach, distinct types of results were obtained. Animals in which the OR1a-expressing neuron or the OR49a-expressing neuron is ablated show reduced

chemotaxis to only 1 of the 20 odors tested. This mild effect is consistent with the broad and overlapping ligand tuning of many ORNs in adults (Hallem et al. 2004) and larvae (Kreher et al. 2005). In contrast, loss of the neuron expressing OR42a results in a lack of behavioral responses to 4 of the 20 odors. In the additive approach, larvae with 1 or 2 functional ORNs are generated using *Or1a*, *Or42a*, or *Or49a* driver lines (Fishilevich et al. 2005). Consistent with the stronger OR42a-ablated phenotype, OR42a-functional larvae behaviorally respond to 22 of the 53 odors tested (compared with 36 odors in the wild type), including 3 of the 4 odors to which OR42a-ablated animals are unresponsive. The broad behavioral response profile for OR42a-functional larvae is in agreement with the broad ligand tuning of this receptor (Goldman et al. 2005; Kreher et al. 2005). In contrast, OR1a- and OR49a-functional larvae do not exhibit significant chemotaxis to any of the 53 odors, consistent with the weak phenotype of the corresponding ablated larvae and with electrophysiological responses (Kreher et al. 2005). Animals with 2 pairs of functional ORNs respond to a somewhat different subset of odors, or with enhanced chemotaxis, than larvae having a single functional pair of neurons alone, suggesting cooperativity (Fishilevich et al. 2005).

Three major conclusions can be drawn from these data. First, the minimal effects on chemotaxis after ablating the OR1a or OR49a neuron may suggest that either these neurons do not participate in processing the tested panel of odors or there is functional redundancy with respect to these odors. Second, the OR42a neuron plays a particularly important role in odor detection: It is sufficient to initiate chemotaxis to a high fraction of odors, and its loss leads to severe behavioral defects. Why there is functional heterogeneity between the OR42a neuron and the OR1a or OR49a neuron remains unclear. Finally, cooperative action is suggested by the overadditive chemotactic responses of OR1a/OR42a-functional animals compared with the single functional animals. Olfactory coding thus does not simply rely on additive activation of 21 parallel pathways but involves horizontal interactions as well. Such cross talk may occur at many levels of the circuit, from the sensory neurons themselves to olfactory target neurons in the brain. The primary candidates are local interneurons in the LAL that provide lateral connections among glomeruli (Ramaekers et al. 2005). Significant transformation of olfactory signals between sensory neurons and PNs is indeed known from the AL of both adult (Sachse and Galizia 2002; Lei et al. 2004; Wilson et al. 2004; Wilson and Laurent 2005) and larval insects (Itagaki and Hildebrand 1990). Such a transformation of olfactory signals may relate to quantitative and qualitative parameters, such as detection threshold and odor discrimination ability, respectively, and indeed integrative processes may be particularly crucial if very few channels have to cope with many odors.

Further processing of olfactory signals occurs in higher brain centers, such as the MBs. The different classes of larval

MB neurons, innervating various numbers of calyx glomeruli, obviously allow different modes of signal transfer. Uniglomerular MB neurons receiving input from a single PN may be involved in elementary, labeled-line coding of odor features. In contrast, multiglomerular MB neurons receive input from, on average, 6 PNs, and if activation of 4–6 PNs were required for driving them, these MB neurons may act as coincidence detectors for interpreting combined activity as an odor (Perez-Orive et al. 2002; Heisenberg 2003; Wang, Guo, et al. 2004; Masuda-Nakagawa et al. 2005; Ramaekers et al. 2005). Thus, although both LAL and larval calyx are glomerular, the logic of connectivity is different: LAL glomeruli have stereotypic connectivity between defined ORNs and PNs, whereas calyx glomeruli exhibit stereotypic PN input but, with respect to the multiglomerular MB neurons, provide mostly nonstereotypic, highly combinatorial output (Masuda-Nakagawa et al. 2005) (Figure 2).

Larval versus adult olfactory circuits

The recent reports overall show that the design of the larval olfactory pathway is very similar to the one of adults. However, every ORN and most (if not all) PNs appear to be unique, leading to an almost complete lack of cellular redundancy at the first 2 relay stations in the olfactory pathway (Figure 2). Consequently, any loss of these cells should affect olfactory function more severely than in the adult system. Moreover, the presence of only 21 ORNs and 21 LAL glomeruli suggests that the number of primary olfactory dimensions is reduced in the larva compared with adults with about 50 glomeruli (Laissue et al. 1999). Also, given the uniglomerular patterns of ORNs and PNs and the almost equal number of ORs, ORNs, LAL glomeruli, PNs, and calyx glomeruli, the early levels of the larval olfactory pathway lack convergent and divergent connectivity and are organized

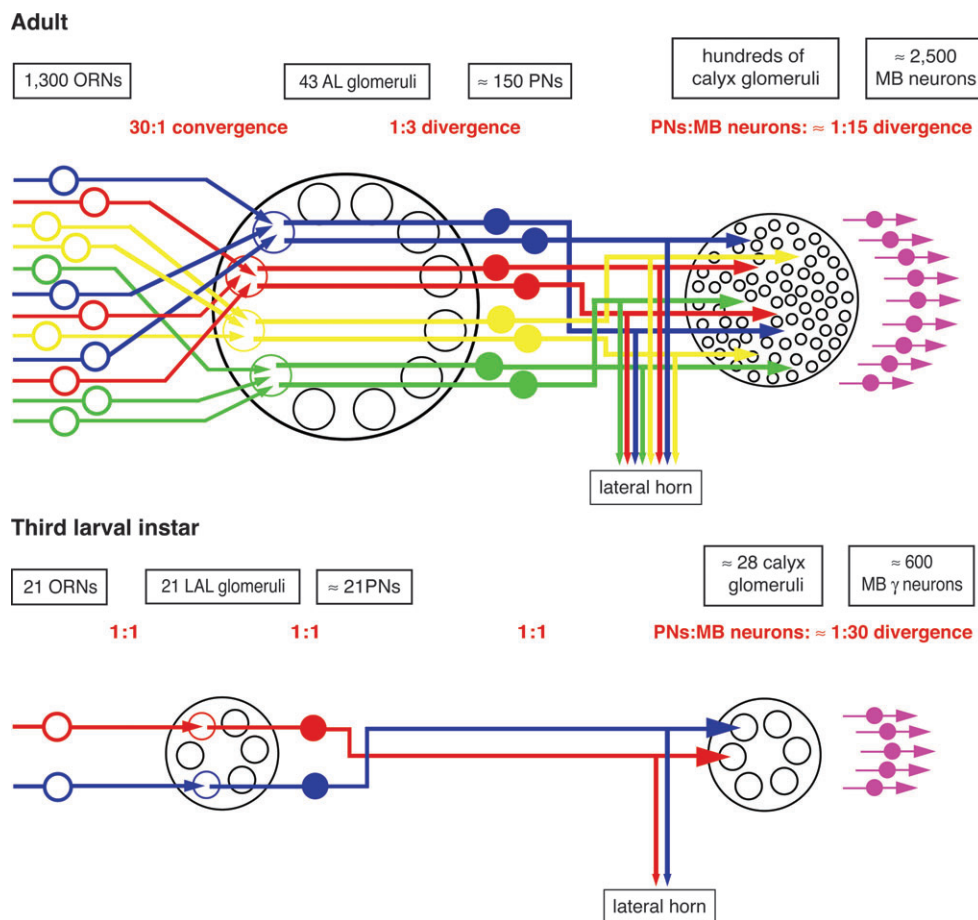

Figure 2 Wiring diagram of the adult versus larval olfactory system. Adult and larval olfactory pathways share the same design. However, in the adult, there are probably more primary olfactory dimensions as suggested by the number of types of ORNs (shown in different colors) and AL glomeruli. Moreover, in the adult, the different types of ORNs (open circles) and PNs (filled circles) that innervate a particular AL glomerulus occur in multiple copies, whereas larval ORNs and PNs are unique. Thus, the adult olfactory pathway is characterized by converging and diverging connectivity in the AL (ratios indicated refer to the features shown in the preceding line), whereas the larval pathway is organized without cellular redundancy. As indicated, larval ORNs, LAL glomeruli, PNs, and calyx glomeruli are related essentially in a 1:1:1:1 fashion. The larval MB calyx retains a combinatorial representation of the AL glomerular pattern, which is not obvious in the adult. For reasons of lucidity, the most nonstereotypic, highly combinatorial output of MB neurons in the calyx is not depicted. Note also that the local interneurons in the AL, which shape olfactory activity, are present in both larva and adult, but are omitted in this figure. From Ramaekers et al. (2005). Elsevier as copyright holder kindly granted permission to use this figure.

in a 1:1:1:1:1 manner (Ramaekers et al. 2005). This contrasts with the adult olfactory pathway, where 1300 ORNs express at least 43 ORs and converge onto about 50 glomeruli, which diverge again to approximately 150 PNs and hundreds of calyx glomeruli (Stocker 1994, 2001) (Figure 2). Finally, distinct from the adult situation, ORN projections remain ipsilateral in the larva; whether and which kind of functional consequences this entails is unclear.

Convergence and cellular redundancy in sensory systems increase the signal-to-noise ratio, whereas divergent connections can expand the dimensionality of the signals to make them more discriminable (Nowotny et al. 2005). In the larva, the lack of cellular redundancy, the low number of input channels, and the absence of a convergence/divergence architecture in the LAL are likely to reduce the signal-to-noise ratio, discriminative power, and the sensitivity of their olfactory system. However, its performance seems still adequate for an animal that lives on its food supply and obviously is good enough to solve simple discrimination learning tasks (see Learning).

Primary gustatory centers

In the adult, gustatory afferents from the pharynx, labellum, and legs travel through different nerves and terminate in distinct regions of the SOG (Stocker and Schorderet 1981; Thorne et al. 2004; Wang, Singhvi, et al. 2004). Interestingly, neurons that are located on different positions and project to different regions may express the same receptor, suggesting that the same tastants may trigger different behaviors, depending on the stimulation site. Moreover, labellar neurons expressing putative “bitter” receptors such as GR66a project bilaterally along the midline of the SOG, whereas terminals of labellar neurons expressing the trehalose receptor gene *Gr5a* extend to additional, lateral regions and do not cross the midline (Thorne et al. 2004; Wang, Singhvi, et al. 2004). Hence, the 2 types of neurons that mediate aversive and attractive responses, respectively (Marella et al. 2006), establish distinct but partially overlapping projections.

A number of recent data allow to draw some conclusions also about the organization of larval taste centers (Scott et al. 2001; Colomb et al., in preparation). Using *Gal4* driver lines in conjunction with FLP-outs, 4 major target subregions were identified in the larval SOG (Colomb et al., in preparation) that seem to be correlated primarily with the nerve through which the afferents travel and less with the *Gr* gene expressed. As in the adult, neurons in different sense organs but expressing the same gene, such as *Gr2a*, may have different central targets (Scott et al. 2001; Colomb et al., in preparation). Circumstantial evidence suggests that afferents involved in attractive responses (Heimbeck et al. 1999) may project to a region slightly different from the 4 subregions mentioned (Colomb et al., in preparation). Finally, it should be noted that *Gal4* lines driven by *Or30a*, *Or42a*, and *Or49a* promoters that show additional expression in the TO also label sensory terminals in the SOG (Kreher et al. 2005).

Regarding second-order gustatory neurons, the discovery of a genetically defined set of approximately 20 neurons in the larval SOG was an important step; these neurons seem to receive input from GR neurons and provide output to the ring gland, the protocerebrum near yet outside the MB calyces, pharyngeal muscles, and ventral nerve cord (Melcher and Pankratz 2005). They express the *hugin* gene, which generates 2 neuropeptides; these are upregulated in the absence of the feeding-regulatory transcription factor *klumpfuss* (P[9036]) and downregulated by amino acid-deficient conditions. On the cellular level, blocking synaptic output from *hugin*-expressing neurons increases feeding (in the adult fly). These data, together with their connectivity, may suggest that these first-order gustatory interneurons integrate taste processing, the endocrine system, higher order brain centers, and motor output. Given that a subset of *hugin*-expressing neurons is likely also dopaminergic (Melcher and Pankratz 2005), it will be interesting to extend these studies to see how feeding behavior in the *Drosophila* larva, an indeed notorious feeder, is neuronally orchestrated by biogenic amines and how gustatory input drives associative reinforcement signals as carried by these amines (Schroll et al. 2006).

Larval contributions to the adult chemosensory system

Olfactory system

In holometabolous insects, larval sensilla are embryonic born and are typically lost during metamorphosis; they become replaced by postembryonic born, adult-specific sensilla that derive from imaginal discs (reviews: Levine et al. 1995; Truman 1996; Tissot and Stocker 2000). However, the recent demonstration of a persisting subset of larval visual sensory neurons and their integration into adult visual pathways (Helfrich-Förster et al. 2002; Malpel et al. 2002) already prepared for surprises. Metamorphosis of central circuits, as shown by a recent larval brain atlas (Pereanu and Hartenstein 2006), involves essentially the integration of a set of secondary neuronal lineages into a preexisting, embryonic-born tract system.

Concerning chemosensation, the metamorphic fate of DO and TO is not the same. Whereas the TO undergoes early apoptosis, the ganglion of the DO moves progressively backward from its peripheral site (N Gendre, personal communication). The larval ORNs become intimately associated with the antennal imaginal disc, that is, the origin of adult ORNs. Adult ORN afferents join and extend through the larval antennal nerve (Tissot et al. 1997) and reach the brain by 16–20 h after puparium formation (Jhaveri et al. 2000). A number of studies have focused on the ingrowth of adult olfactory afferents and their role in adult glomeruli formation (Jhaveri et al. 2000, 2004; Jhaveri and Rodrigues 2002; Hummel et al. 2003; Hummel and Zipursky 2004; Komiyama et al. 2004; Sen et al. 2005).

The adult AL derives from a brain region distinct from the LAL (Jefferis et al. 2004). In the LAL, the larval ORN terminals become gradually pruned (Jefferis et al. 2004). Many, perhaps all, larval olfactory interneurons become integrated in the adult system. Early reports referred to a persisting serotonergic neuron in *Manduca* with arborizations in the AL and protocerebrum (Kent et al. 1987; Oland et al. 1995). Local GABAergic interneurons occur both in the LAL and adult AL of several species, but it is not certain whether they are identical at both stages (Homberg and Hildebrand 1994; Stocker et al. 1997; Python and Stocker 2002b). Larval PNs in *Drosophila* obviously survive through metamorphosis (Stocker et al. 1997; Jefferis et al. 2001; Marin et al. 2005). In the adult AL, at least 15 glomeruli are innervated by embryonic-born PNs. These glomeruli are distinct from those innervated by larval-born PNs. The embryonic-born PNs in the adult circuit are very likely the same cells as the mature larval PNs (Marin et al. 2005). Until 12 h after puparium formation, their dendritic processes in the LAL are gradually pruned and ultimately disappear, together with LAL neuropil as a whole. At the same time, new dendritic arbors grow from the main PN process at a novel site, dorsal and posterior to the LAL. This secondary area then develops into the adult AL (Jefferis et al. 2004; Marin et al. 2005). The distinct site of the adult AL neuropil from the LAL and the minimal invasion of the former by larval ORN terminals or the “original” larval PN dendrites suggests that larval elements do not supply crucial patterning information for the adult AL (Jefferis et al. 2004; Marin et al. 2005).

The postembryonically born, adult-specific PNs extend their axons during the third larval instar, and only by the wandering stage, they have reached the MB calyx and lateral horn (Jefferis et al. 2004). Dendritic arborizations do not appear before puparium formation, demonstrating that these PNs are not functional in the larval system. Interestingly, the dendrites of the adult-specific PNs invade the prospective adult AL a few hours before those of the persisting larval PNs (Jefferis et al. 2004), further demonstrating that larval elements are not crucially involved in patterning the adult lobe.

Hence, the persisting, embryonic-born PNs are functionally integrated in both larval and adult olfactory pathways. It will be interesting to compare whether these PNs serve similar function at both stages, in particular, with respect to response spectra and the kinds of behavioral responses supported.

Concerning larval MB intrinsic neurons, their persistence through metamorphosis is well documented (Technau and Heisenberg 1982; Armstrong et al. 1998). A set of 4 MB neuroblasts divides continuously from embryonic to late pupal stages, giving rise first to the larval-type MB γ neurons and then successively to the adult-specific α'/β' and α/β neurons (Lee et al. 1999; Jefferis et al. 2002). Similar to the situation in PNs, the embryonic-born MB γ neurons prune

their larval dendrites and axons to some extent before reextending them in modified form.

Gustatory system

A few hours after puparium formation, the cells of the external taste sensilla, that is, of the TO and very likely also of the VO, lose coherence, accumulate caspases, and disintegrate, suggesting that they undergo apoptosis (N Gendre, unpublished data). They are replaced by an entire set of adult-specific labellar taste bristles and taste pegs, which derive from the labial imaginal disc (Ray et al. 1993; Ray and Rodrigues 1994).

In contrast, lineage tracing with horseradish peroxidase (Technau 1986) and FLP-out induction (Wong et al. 2002) at embryonic stages in the neuron-specific driver line MJ94 demonstrates that most pharyngeal sensilla of the larva survive (Figure 3) (Gendre et al. 2004). This is surprising because the pharynx itself undergoes extensive reorganization (Gehring and Seippel 1967; Struhl 1981). An exception is the ventral pharyngeal sense organ, which disintegrates and likely undergoes apoptosis. The posterior

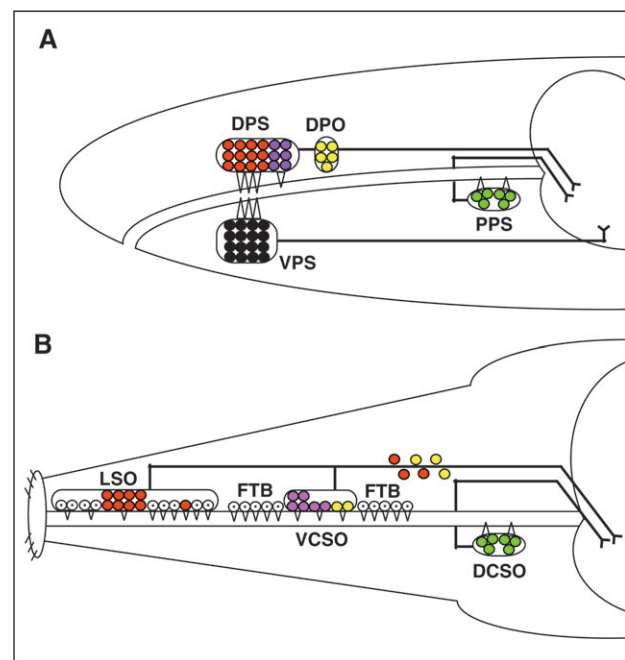

Figure 3 Metamorphosis of the pharyngeal sensory system. The metamorphic transformation of the pharyngeal sensory apparatus of the larva (A) is a complex process involving persisting neurons (shown in color), neurons undergoing apoptosis (black), and newly born neurons (dotted). The posterior pharyngeal sense organ (PPS) of the larva is conserved through metamorphosis and becomes in the adult (B) the dorsal cibarial sense organ (DCSO). The ventral pharyngeal sense organ (VPS) of the larva is lost, whereas the dorsal pharyngeal sense organ (DPS) splits into the adult labral sense organ (LSO) and the adult ventral cibarial sense organ (VCSO). The VCSO includes 2 neurons of the “dorsal pharyngeal organ” (DPO) of the larva. Additional neurons of the LSO as well as the fish-trap bristles (FTB) are born during metamorphosis. From Gendre et al. (2004). The Company of Biologists as copyright holder kindly granted permission to use these figures.

pharyngeal organ on the other hand, including its central projections, survives through metamorphosis and becomes an anatomically almost identical adult organ, the dorsal cibarial sense organ (Gendre et al. 2004). A yet different developmental route is taken by the dorsal pharyngeal organ, which undergoes a complex transformation and splits into 2 parts, becoming the ventral cibarial sense organ and the labral sense organ in the adult. The latter organ is further characterized by the addition of new sensilla during pupal life, as shown by the application of the mitotic marker bromodeoxyuridine. Thus, from the 32 sensory neurons of the 3 adult pharyngeal organs, 23 are likely persisting larval neurons, whereas the remaining ones arise during metamorphosis (Figure 3). In conclusion, metamorphosis of the pharyngeal sensory system is an intricate process involving neuronal death, generation of new neurons, and, surprisingly, persistence of many embryonic-born neurons.

The persistence of sensory neurons and their central projections through metamorphosis suggests some continuity of gustatory target regions. This may aid navigating imaginal afferents toward and inside the central nervous system (Usui-Ishihara et al. 2000; Williams and Shepherd 2002) or allow the persistence of specific feeding-associated gustatory tasks through metamorphosis. Alternatively, “recycling” of neurons might simply be due to reasons of economy (Tissot and Stocker 2000). In any event, the survival of GR neurons suggests similarity of pharyngeal taste function between larval and adult stages.

Smell and taste systems: outlook

The usefulness of adult *Drosophila* as a model system in olfactory research is evident, given the genetic and molecular tools available in this species, the simplicity of its olfactory system in terms of cell number, and—last but not least—the striking similarities with the mammalian olfactory system with respect to OR expression patterns, glomerular OR convergence, and coding principles in the primary odor center. Surprisingly, the olfactory system of the larva also shows the same basic design as the mammalian system, but almost in the simplest conceivable form. Excitingly, larvae with a single pair of functional ORNs can be generated. In such animals, OR expression, electrophysiological, and behavioral responses can be directly correlated, allowing the analysis of olfactory behavior at the level of single, identified receptor cells. Thus, the larva may turn into an attractive model for olfactory studies.

Concerning gustation, the model character of *Drosophila* as compared with mammals is less obvious, both with respect to adults and larvae. Anatomically, the taste systems of mammals and insects are different. Nevertheless, there are a number of interesting parallels. In both insects and mammals, taste receptor cells seem to be tuned to classify inputs as either attractive or aversive. Moreover, many more of the taste receptor proteins seem dedicated to repulsive ligands

than to attractive ones. Strikingly also, in both phyla cells responding to bitter substances express multiple receptors.

The parallels in the chemosensory systems of mammals and insects are not necessarily an argument in favor of their common ancestry. This is reflected, for example, by the nonhomology of the receptor gene families in both phyla (Benton et al. 2005). Rather, the similarities may reflect common functional constraints, both for smell and to a lesser extent also for taste. Understanding these constraints may aid our understanding of chemosensory function. In this sense, the simplicity of the olfactory and gustatory systems of *Drosophila* and the wealth of available molecular tools may contribute to our comprehension of smell and taste in general.

Learning

Unlike a computer hard disk, the function of biological memory is not to faithfully document the past; rather, associative memory uses past experience to predict the future—be it the consequences of an animal’s own actions or upcoming external events. These predictions then can contribute to the selection of behavior. Given the larva’s cellular simplicity and experimental accessibility, a multilevel understanding of such learning should be comparably easy.

Two larval learning paradigms will be presented here, one for associating olfactory stimuli and the other for associating visual stimuli with gustatory reinforcement. We provide some detail about the used methods and then review recent findings, mainly concerning the olfactory learning paradigm. As a first step, however, we consider the responses of experimentally naive larvae to odors, as well as the consequences of odor exposure on subsequent odor responses; this seems important to appreciate the kinds of behavioral control procedures one needs to use when investigating associative learning.

Odor responses and behavioral consequences of odor exposure

The best starting point to understand how the olfactory system works is to watch it at work, that is, to observe the animal’s responses to odors. The typical setup for larval *Drosophila* is to place them in the middle of an agarose-filled petri dish, which provides a solid, smooth, and slightly lubricated surface on which the larvae readily move around. On one side of the petri dish, an odor source is placed. After some minutes, the number of animals located on the odor side minus those on the odorless side is determined, and this difference is divided by the total number of animals. This provides a normalized odor preference score ranging from full attraction (+1) to full repulsion (−1). The salient feature of such experiments is that larvae are attracted by odors; however, closer inspection (Boyle and Cobb 2005) reveals that, similar to adult flies (Rodrigues 1980), this is a concentration-dependent effect. At very low concentrations, larvae

behave indifferently, at low-to-medium concentrations they are attracted, but as concentration further increases, they eventually are repelled by the odor. In cases where only attraction or repulsion is observed, this may be due to testing a too restricted range of concentrations; this is understandable as generating very high or very low odor concentration is technically challenging.

Obviously, if larvae move toward or away from an odor, they can detect that odor. This, however, does not address the question whether they can distinguish it from another one. Similarly, if larvae show a relative preference for one odor over another, discrimination cannot be inferred. This is because both odors may drive the same set of ORNs, but to a different extent (because they differ in e.g., vapor pressure or in affinity to the ORs); consequently, one odor may be quantitatively a stronger attractant without being perceived as qualitatively different. Are cross-adaptation experiments suitable to tackle this issue? Such experiments exploit the observation that, after exposure to a stimulus A, behavioral responses to this stimulus decrease and may eventually cease; if this effect can be shown to be due to an effective shutdown of the respective sensory input lines, one speaks of sensory adaptation. Provided that such adaptation does occur and provided that the peripheral nature of this effect can be shown, the experiment can be modified to first expose to stimulus A and then to test for the behavioral response to stimulus B (and in independent, complementary experiments to expose to B first to then test A). If this cross-exposure remains without effect in both cases (symmetrical lack of cross-adaptation), one can safely conclude that there must be at least 2 functionally independent input lines in the sensory system. If in both cases there is a full abolishment of the responses to the nonexposed odor (symmetrical cross-adaptation), it is parsimonious to argue that only one input line exists, which can be driven by either stimulus (the most frequent cases of partial or of asymmetrical cross-adaptation are difficult to interpret). This approach can thus be used to determine the minimal number of independent input lines that a given sensory system must possess and thus the potential (sic) of the system to discriminate odors.

Concerning the *Drosophila* larva, odor exposure consistently decreases odor preferences and it may even abolish them (Cobb and Domain 2000; Wuttke and Tompkins 2000; Boyle and Cobb 2005; Michels et al. 2005; Colomb et al. forthcoming). In studies that systematically investigate this decrease in preference, it is interpreted as adaptation (Cobb and Domain 2000; Wuttke and Tompkins 2000; Boyle and Cobb 2005) and used to establish functional models of the larval olfactory system. However, recent research (Boyle and Cobb 2005; Colomb et al. forthcoming) shows that exposure in many cases does not only abolish odor preference but instead reverts the odor response from attraction to aversion, an effect that, without receiving much emphasis, had already been observed earlier (Cobb and Domain 2000).

Further inspection reveals that the typical dose–response curve from attraction at low to aversion at high odor concentrations retains its shape but is shifted “downward,” that is, toward aversion (Boyle and Cobb 2005; Colomb et al. forthcoming). Moreover, for odors that even at low concentrations are repulsive, exposure yet further increases this repulsion (Boyle and Cobb 2005). This shows that odor exposure does not render the olfactory system unresponsive and therefore casts doubt on interpretations invoking adaptation of the sensory input pathways to explain odor-exposure effects (Cobb and Domain 2000; Wuttke and Tompkins 2000; Boyle and Cobb 2005). Rather, it seems as if odor exposure, by an as yet unknown mechanism, leads to a change in value or “liking” of the exposed odor (for a more detailed discussion, see Colomb et al. forthcoming).

Taken together, in the *Drosophila* larva odor-exposure effects are often observed and can be rather strong, even with relatively mild exposure. Odor exposure reduces attraction, in some cases turning it into aversion. In cases where the response in experimentally naive larvae already is an aversion, odor exposure may further increase this aversion. Although common and strong, however, the nature of the odor-exposure effect remains obscure; what is clear is only that a shutdown of olfactory input cannot fully account for the available data. Thus, accounts of sensory processing that rely on odor exposure effects, that is, on cross-adaptation experiments, must remain tentative.

Reciprocal associative learning paradigms

Both associative learning paradigms developed recently (Scherer et al. 2003; Gerber, Scherer, et al. 2004) use a 2-group, reciprocal training design: in the first group, stimulus A is presented with gustatory reward and another stimulus B without reward (e.g., A+/B). The other group receives reciprocal training (A/B+) (Figure 4A). Subsequently, animals are individually tested for their preference between A versus B (a follow-up version uses en masse testing: Michels et al. 2005; Neuser et al. 2005). Relatively higher preferences for A after A+/B training than after A/B+ training then reflect associative learning and can be expressed as a learning index. The conclusion regarding the associative nature of the learning index is compelling because other parameters, such as stimulus exposure, reward exposure, passage of time, or handling, do not differ between the reciprocally trained groups. Other experimental designs that do not use reciprocally trained groups (Honjo and Furukubo-Tokunaga 2005) may not be measuring such a “purified” associative effect. Furthermore, in a reciprocal training design, it is not relevant whether animals in both groups have an overall tendency to prefer for example stimulus A over stimulus B in the test; this is because overall preferences in both groups can cause an offset of preferences in both groups but cannot cause differences between them.

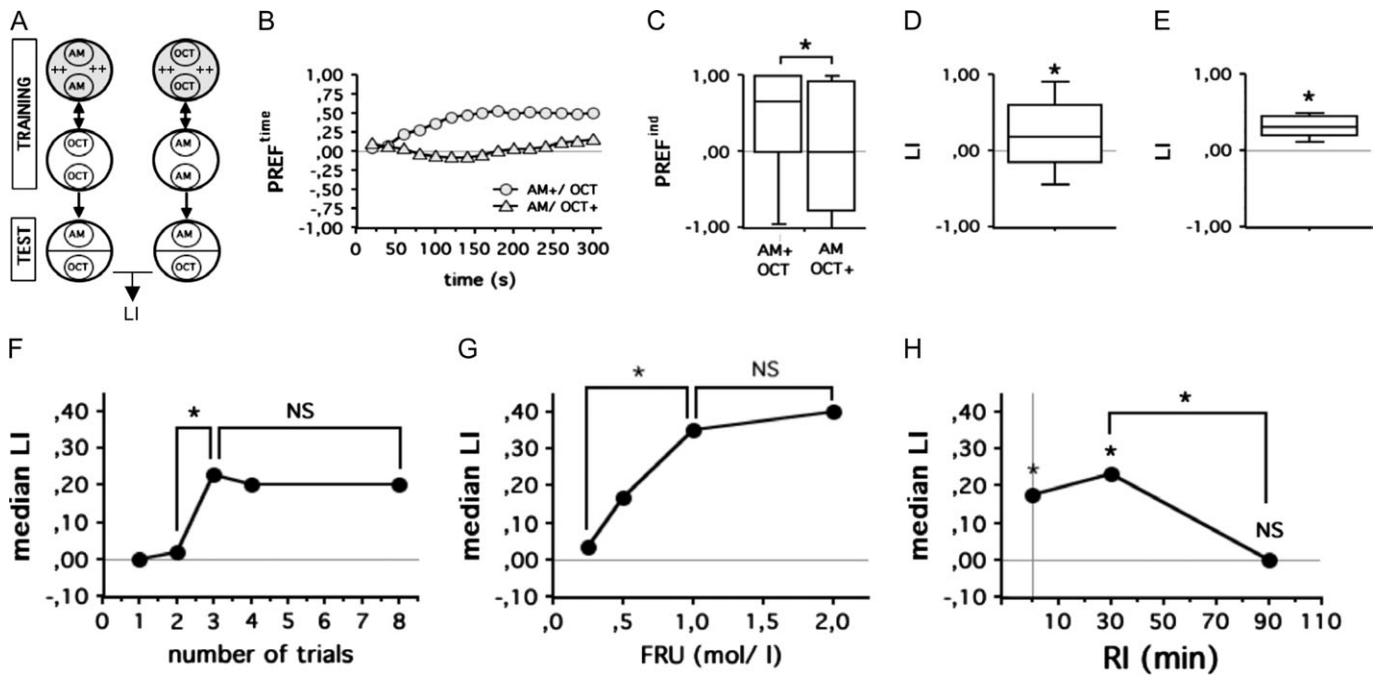

Figure 4 Appetitive olfactory learning. **(A)** Sketch of the learning experiment showing the sequence of training trials. Note that for half of the cases, the sequence of training trials for the reciprocal groups is as indicated (i.e., AM+/OCT and OCT+/AM); for the other half of the cases (not shown), the sequence of training trials is reversed (i.e., OCT/AM+ and AM/OCT+). **(B)** After training, individual larvae are observed for 5 min and are scored every 20 s as being located on either the AM or the OCT side. For each time point, odor preferences are calculated as the number of animals located on the AM side minus the number of animals located on the OCT side, divided by the total number of animals. Thus, positive values indicate that a majority of larvae are recorded on the AM side at that time point, whereas negative values indicate that a majority is located on the OCT side. **(C)** The preference values [−1 to 1] are calculated for each animal as the number of times a given animal is observed on the AM side during the test minus the number of times that animal is observed on the OCT side, divided by the total number of observations. The AM preference is higher after AM+/OCT training relative to the AM preference after AM/OCT+ training, indicating associative learning. Note that for this conclusion to be valid, it is this difference between the reciprocally trained groups that matters and not the overall AM preference. That is, if all values were offset by say ± 0.2 , the conclusion regarding associative learning remained valid. **(D)** A learning index (LI) [−1 to 1] is calculated for pairs of animals that underwent either of the reciprocal training regimes, for example, either AM+/OCT or AM/OCT+, by subtracting the preference (PREF) values of both animals; as this difference can range from −2 to 2, it is divided by 2. The LIs are significantly larger than zero, indicating associative learning. **(E)** LIs of a modified version of the learning experiment, which uses en masse testing of approximately 30 animals. After training, larvae are allowed 3 min to distribute between AM and OCT; then, preference values are calculated as the number of animals on the AM side minus the number of animals on the OCT side, divided by the total number of animals. The LI then is calculated as mentioned in (D). Note that in this en masse version of the assay, the scatter of the LIs is substantially reduced (compare Figure 4D with 4E; see also Figure 6A vs. A'). **(F–H)** Parametric analyses of appetitive olfactory learning. LIs increase with the number of training trials (F), the concentration of the reward (G), and are stable for at least 30 min after training (H). *, $P < 0.05$; NS, $P > 0.05$, nonparametric statistics being used throughout: for comparisons of single groups against zero, one-sample sign tests are used; comparisons between any 2 groups are performed by Mann–Whitney *U*-tests and are performed only after across all group comparisons (not shown) with a Kruskal–Wallis test are found to be significant. The box plots (C–E) represent the median as the middle line and 10% and 90%, and 25% and 75% quantiles as whiskers and box boundaries, respectively. Sample sizes per box plot for the single-animal assay (D, F–H) range from about 40 to about 100, whereas for the en masse version of the assay (E) sample sizes can be much lower ($N = 15$ in this case). From Neuser et al. 2005. Elsevier as copyright holder kindly granted permission to use these figures.

Learning experiments with larvae are performed in petri dishes filled with solidified 1% agarose. Fructose (2 M) is used as a reward; in some studies (Scherer et al. 2003; Gerber, Scherer, et al. 2004; Hendel et al. 2005; Gerber and Hendel 2006), either high-concentration sodium chloride (4 M) or quinine (0.2% w/w) is used in addition as punishment for a push–pull design (push–pull referring to an experimental design in which one stimulus is rewarded and another stimulus is punished). These substances are added to the agarose before being poured into the petri dishes. When used on the following day, this ensures a smooth, slightly lubricated surface that is either sweet, salty, bitter, or without obvious taste.

Olfactory learning

In the case of olfactory learning, experiments typically are performed under a fume hood and under red light (but see Yarali et al. 2006). Isoamylacetate (AM) and 1-octanol (OCT) are used as odorants to be associated with the tastants: for one group, AM is presented with reward and OCT without reward (AM+/OCT), whereas the second group is trained reciprocally (AM/OCT+) (Figure 4A). In the subsequent test, a higher AM preference is found in animals that had undergone AM+/OCT training as compared with the ones that had received AM/OCT+ training (Figure 4B,C) (Hendel et al. 2005; Michels et al. 2005; Neuser et al.

2005; Yarali et al. 2006). It is this difference in preference between the reciprocally trained groups that is indicative of associative learning. As is done for adult flies, this relative difference in preference, and hence the learning success, can be quantified by a learning index (Figure 4D–H) (for a statistical validation of the learning index, see Hendel et al. 2005). Notably, for the conclusion that associative learning does occur, it is the difference between the reciprocally trained groups that matters, not the overall level of odor preference. That is, if all preference values in Figure 4B,C were offset by say ± 0.2 , the learning index and the conclusion regarding associative learning would remain unaltered. However, as is done for adult learning, odor concentrations are usually adjusted such that naive larvae show an about-equal distribution between both odors. This is important for practical reasons: a very strong preference for an odor would be hard to overcome by training. In other words, a strong overall odor preference could cause a reduction in the learning index but due to the reciprocal training design cannot generate a false-positive learning index.

Odors are supplied by evaporation from 5-mm diameter custom-made Teflon containers that can be closed by a perforated lid (seven 0.5-mm holes) and that are placed onto the agarose surface of the petri dish. This allows evaporation of odor but prevents gustatory contact. The lids of the petri dish are also perforated to facilitate aeration (15-mm array of 61 concentrically arranged 1-mm holes). Under such conditions, and in accordance with earlier work using different details of odor application, larvae are usually attracted by odors (see Odor responses and behavioral consequences of odor exposure). This method of odor application is admittedly crude but obviously allows the larvae to distinguish the previously rewarded from the nonrewarded odor and to behave accordingly. Also, it allows detecting effects of odor concentration on preference (Scherer et al. 2003) (see also e.g., Boyle and Cobb 2005). Notably, for such a low-tech setup, the threshold to try it out in other laboratories is low.

Parametric analyses of appetitive olfactory learning

The study by Neuser et al. (2005) provides parametric analyses of appetitive olfactory learning. It shows that learning success increases with the number of learning trials and that learning reaches asymptote after 3 trials with the rewarded and the unrewarded odor each (Figure 4F). This makes it possible to obtain statistically significant learning scores in 250 min of experimental time.

Learning success increases with reward strength, 2 M fructose supporting asymptotic levels of learning (Figure 4G); the ensuing memory is stable for at least 30 min; after 90 min, there is no measurable learning effect left (Figure 4H). Such a 30-min time window allows to use pharmacological agents, amnesic treatments, and temperature-induced block of synaptic output in genetically defined cells (via targeted expression of a dominant negative, temperature-dependent dynamine transgene, *shibire^{ts}*; Kitamoto 2001). Finally, nei-

ther larval age (tested 4, 5, and 6 days after egg laying) nor gender have an apparent impact on learning scores.

In addition to the experiments on individually assayed larvae reviewed so far, an en masse version of olfactory learning is feasible. The procedures are basically the same as mentioned before, except that animals are trained and tested in groups of 30. Under these conditions, the scatter of the learning data is substantially reduced (Figures 4E and 6A'). Thus, the en masse version seems more powerful to uncover between-genotype differences (compare Figure 6A to 6A'). This is why, different from most data published to date (exception being the data displayed in Figures 4E, 6A', and 7), this version of the assay is used in those current experiments on larval learning that we are aware of.

Effectiveness of reward, but not punishment?

A push–pull design, that is, rewarding one and punishing the other stimulus, initially seemed warranted to yield maximal learning effects (Scherer et al. 2003). It leaves pending, however, the question to which extent memory is due to reward or punishment. Surprisingly, memory seems exclusively due to the reward (Figure 5) (Hendel et al. 2005): reward-only but not punishment-only training yields significant learning effects (Figure 5A). Furthermore, learning indices after reward-only training are as high as after reward–punishment training (Figure 5B). The apparent ineffectiveness of punishment is not due to an inability of the larvae to detect salt and quinine, as they show strong aversion to both salt and quinine (Figure 5C), and as both salt and quinine suppress feeding in a colored-agarose feeding assay (Figure 5D). Also, salt and quinine are not to such an extent unpleasant as to prevent attention to any other stimulus or to intoxicate the animals because 1) punishment used in reward–punishment training does not decrease learning scores below reward-only training (Figure 5B), and 2) neither the presence of salt nor the presence of quinine disturbs olfactory behavior in experimentally naive animals (Hendel et al. 2005). The simplest interpretation thus seems to be that salt and quinine, although aversive stimuli, have no apparent effect as reinforcers in these learning paradigms.

However, it turned out that both salt and quinine actually are effective as reinforcers but that the respective memories established are not expressed in behavior (Gerber and Hendel forthcoming). Uncovering these “hidden” memories was guided by psychological research: That is, much in contrast to the usual view on behavior as a passive, stimulus-evoked process, outcome-driven models of behavior control suggest that behaviors are expressed if their outcomes offer a benefit (Dickinson 2001; Elsner and Hommel 2001; Hoffmann 2003). Consider that after training with sugar, the test offers the larvae a binary choice situation with one odor suggesting “over there you will find sugar” and the other suggesting “over there you will not find sugar.” In the absence of sugar, larvae should go toward the sugar-associated odor (search for the predicted reward). If

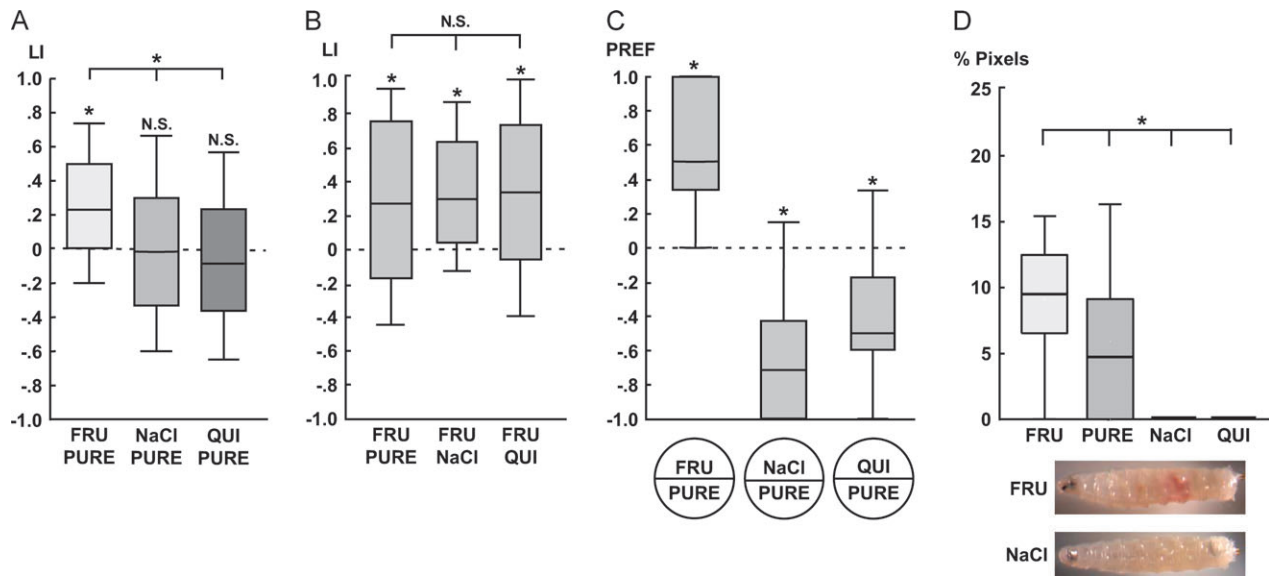

Figure 5 Apparent effectiveness of reward, not of punishment. **(A)** Learning indices (LIs) after reward-only training using fructose (FRU) as reward in a AM+/OCT versus AM/OCT+ design, as compared with punishment-only training using either high-concentration sodium chloride (4 M NaCl) or quinine hemisulfate (0.2% QUI) as punishment (AM-/OCT vs. AM/OCT-). Obviously, reward-only but not punishment-only training is effective. This lack of memory scores after aversive learning likely reflects a lack of behavioral expression of memory, rather than a lack of learning (Gerber and Hendel forthcoming) (see text for details). **(B)** LIs after reward-only training using FRU as reward (AM+/OCT vs. AM/OCT+) are as high as after reward-punishment training (AM+/OCT- vs. AM-/OCT+) using FRU/NaCl or FRU/QUI as reward-punishment combinations. **(C)** Larvae show appetitive responses to FRU and aversive responses to both NaCl and QUI in a split petri dish assay; larvae are put in the middle of the plate and after 15 min are scored as located on either side. The preference is then calculated as mentioned in the legend of Figure 4C. **(D)** FRU stimulates, but both NaCl and QUI suppress feeding relative to the “untasted” control. For these experiments, the respective substrates have a dye (carmine red) added, so that the proportion of red-stained pixels can be determined after the larvae were allowed to stay on the respective substrate for 15 min. In all cases, PURE refers to an agarose-filled petri dish (or the half of a such a dish in C) without any tastant added. *, $P < 0.05$; NS, $P > 0.05$; for comparisons of single groups against zero, one-sample sign tests are used; comparisons between multiple groups are performed by Kruskal-Wallis tests. Other details are as in Figure 4. Sample sizes for each box plot are about 60, except for (B) that is based on about 100 values. From Hendel et al. (2005). Springer Science and Business Media as copyright holder kindly granted permission to use these figures.

sugar already is present, however, tracking down that odor would not offer any improvement. In contrast, after aversive training, one odor may suggest “here you will suffer from quinine,” whereas the alternative suggests “here you will not suffer from quinine.” Thus, if quinine is absent, tracking down the no-quinine-associated odor would not offer any advantage. In the presence of quinine, however, tracking down the no-quinine-associated odor can lead to relief from quinine, a potential improvement that can drive conditioned behavior (flight from the aversive reinforcer), and this is indeed found (Gerber and Hendel forthcoming). Thus, sugar and quinine (and salt as well) can induce associative olfactory memory traces, but the behavioral expression of these traces is a regulated rather than automated process: first, irrespective of the test situation, the odor activates its memory trace. In the second evaluative step, a comparison is made between the value of this activated olfactory memory trace and the value of the test situation. Only if the value of the odor memory is higher than that of the test situation, tracking down that odor can be expected to improve the situation, and memory will be expressed in behavior. In other words, an “expected outcome” is computed as the difference between the value of the activated memory trace and the

value of the current situation. It is this expected outcome, rather than the activated memory trace per se, that drives conditioned behavior.

Interestingly, as the larvae do not seem to swallow any of the substrate when salt or quinine is present (Figure 5D), one may suppose that the input to the dopaminergic neurons, which are sufficient to mediate aversive reinforcement (Schroll et al. 2006), comes from external rather than pharyngeal gustatory sensilla.

Robustness of appetitive olfactory learning

The versatility of a learning assay depends, among other things, on how easily it can be implemented in other laboratories. For an earlier approach using olfactory learning with electric shock reinforcement (Aceves-Pina and Quinn 1979; Heisenberg et al. 1985; Tully et al. 1994), replicability is compromised (Forbes 1993; F Python and RF Stocker, unpublished data). For another paradigm using gustatory reinforcers (Dukas 1999), we are not aware of follow-up studies.

The above appetitive olfactory learning paradigm has, in its en masse version, in the meantime been established in other laboratories (C. Schuster [Universität Heidelberg, Germany], P. Callaerts [University of Leuven, Belgium],

L. Fradkin/J. Noordermeer [University of Leiden, Netherlands], E. Hafen/H. Stocker [Swiss Federal Institute of Technology, Zürich, Switzerland], R. Nichols [University of Michigan, Ann Arbor, MI, USA], M. Sokolowski [University of Toronto at Mississauga, Canada], R.F. Stocker [University of Fribourg, Switzerland], and T. Zars [University of Missouri, Columbia, MO, USA]. It requires little skill and training, demands no special technical equipment, and affords little cost. This set of features may make it versatile for olfactory learning research.

Feasibility of genetic analyses

In an approach to use appetitive larval olfactory learning for a genetic analysis, a study concerning the *synapsin* gene was initiated (Michels et al. 2005). Synapsin is an evolutionarily conserved and highly abundant presynaptic phosphoprotein (for review, Hilfiker et al. 1999; Ferreira and Rapoport 2002; Sudhof 2004; concerning *Drosophila*: Klagges et al. 1996; Godenschwege et al. 2004). It is associated with both the cytoskeleton and the cytoplasmic side of synaptic vesicles and regulates the balance between the ready-releasable versus reserve-pool vesicles in a phosphorylation-dependent way. Such regulation appears to contribute to the maintenance of synaptic function at sustained, high spiking rates. However, whether this regulatory function entails a role in associative learning had remained elusive. Only since recently, it is clear that mutations in the human *synapsin 1* gene can cause neurological and behavioral phenotypes, including epileptic seizures and, in a subset of patients, learning defects (Garcia et al. 2004; for similar phenotypes in mice, see also Gitler et al. 2004) and psychotic symptoms (Chen et al. 2004). In larval *Drosophila*, the deletion mutant *syn*⁹⁷ carries a 1.4-kb deletion in the *synapsin* gene, spanning a part of the regulatory sequence and half of the first exon (Godenschwege et al. 2004). This deletion leads to an absence of measurable synapsin protein in both larvae and adults and thus qualifies as a null mutant on the protein level. The *syn*⁹⁷ line had been outcrossed for more than 13 generations to the Canton-S wild-type strain (wild-type CS), effectively leading to fly strains (CS and *syn*^{97CS}) that are likely to differ only with respect to the deletion at the *synapsin* locus and thus allow conclusions about synapsin function. Such outcrossing is essential to avoid confounding effects of genetic background, marker genes, and transgenic constructs that can otherwise distort results (Zhang and Odenwald 1995; de Belle and Heisenberg 1996; Diegelmann et al. 2006). In *syn*^{97CS}, Michels et al. (2005) report a reduction in learning ability by about 50% (Figure 6A); motor ability as well as responsiveness to odors (Figure 6B,C) and the fructose reinforcer (Figure 6D) are normal. Also, basic synaptic physiology and the equipment with vesicles, measured at the neuromuscular junction (NMJ), appear to be normal (Godenschwege et al. 2004). This implies that a low level of learning can be achieved without synapsin; beyond that level, however, synapsin is required.

Behavioral controls for mutant learning phenotypes

One problem in the behavioral neurogenetics of learning is to test for the specificity of a learning defect. That is, low scores may, apart from genuine defects in learning, result from more general defects in sensory or motor ability. The usual approach is to compare experimentally naive, untrained animals of the genotypes in question for their responses to the to-be-associated stimuli. For example, concerning odor-taste learning in larvae, one would need to compare naive animals from the different genotypes in terms of 1) their preference between fructose and plain agarose (Figure 6D), 2) their preference between an AM-scented and an unscented control side, as well as 3) between an OCT and control side (Figure 6B,C). The rationale for not testing the relative preference between both odors is that typically odor concentrations are chosen such that naive, wild-type animals show about zero preference between the odors; therefore, one may expect both naive wild-type and naive mutant larvae to be indifferent between them. This indifference, however, may come about for different reasons in these genotypes: the wild type may be truly indifferent, whereas the mutant may be anosmic. This problem of interpretation is avoided if olfactory detection ability, rather than relative preference, is tested. These kinds of behavioral controls are state of the art until to date.

However, one may object that a mutant learning defect is seen after training, that is, after animals had undergone extensive handling, exposure to reinforcers, and exposure to odors. One may therefore argue that the olfactory and motor abilities that the mutants need during test need to be investigated as well (as no gustatory abilities are required during the test, this objection does not apply to the ability of tasting). Therefore, one would like to know whether a given mutant still is able to detect and respond to the odors after a “sham-training” procedure that involves the same handling and general procedure as for training but 1) omits the reinforcer and merely exposes to the odors (Figure 6E,F) and 2) omits the odors and merely exposes to the reinforcer (Figure 6G,H). Intuitively, handling and exposure effects seem likely to exist: handling may stress the animals, change motivation, and/or induce fatigue. Repeated odor exposure may lead to sensory adaptation, habituation, and/or latent inhibition (Cobb and Domain 2000; Wuttke and Tompkins 2000; Boyle and Cobb 2005; Michels et al. 2005; Colomb et al. forthcoming). Sugar exposure and/or uptake may entail motivational changes leading to changed olfactory behavior. We thus have to contemplate the possibility that genotypes differ in any of these kinds of processes, rather than in learning per se. Concerning *syn*^{97CS}, these tests have not revealed any difference between *syn*^{97CS} and wild-type CS (Figure 6E–H).

Clearly, testing responses in naive animals remains important: one needs to know whether at the beginning of training, genotypes may differ with respect to their olfactory and

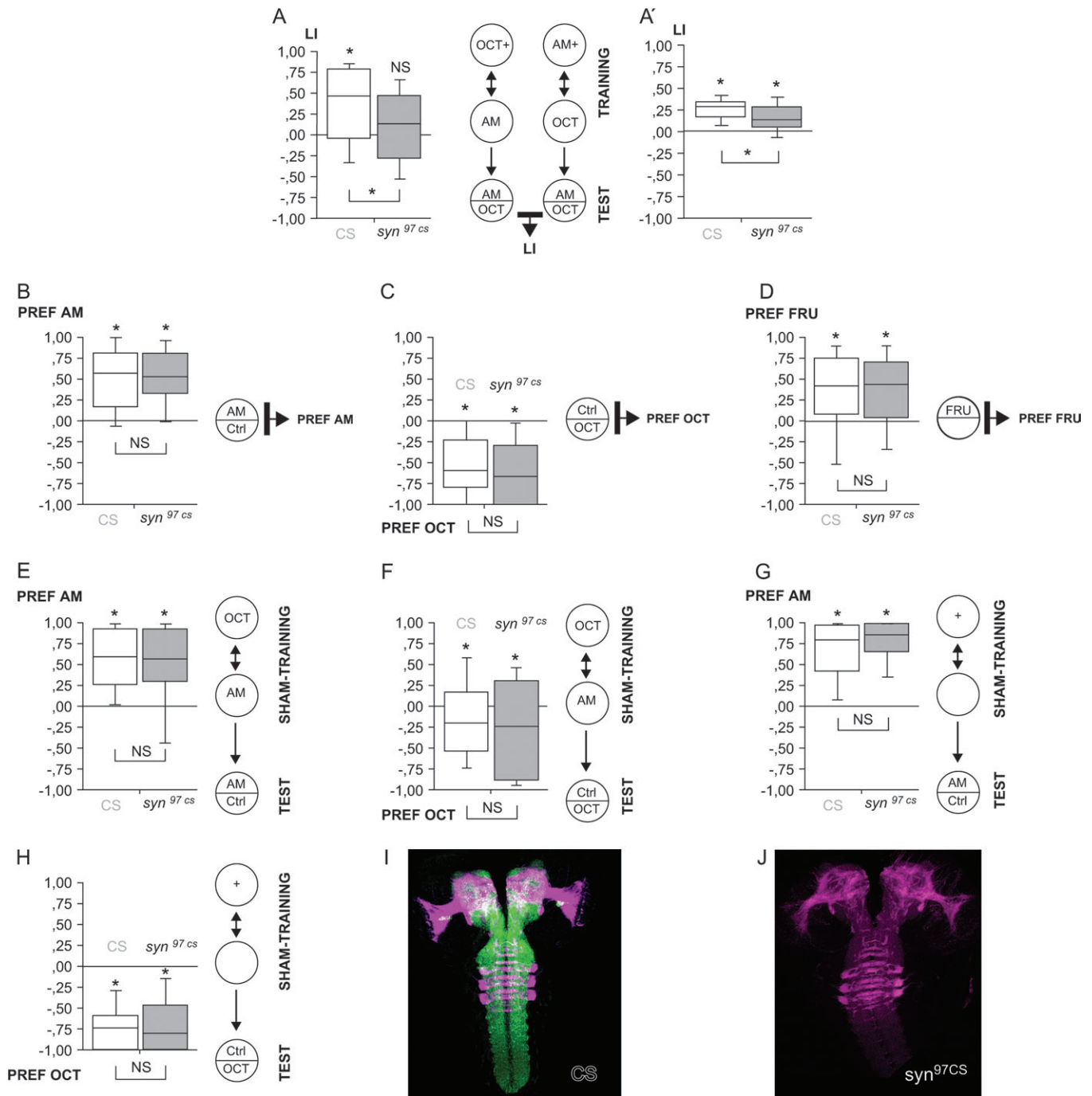

Figure 6 Feasibility of genetic analysis: synapsin as a study case. Open displays refer to the wild-type CS strain, filled displays to the synapsin null mutant (*syn^{97CS}*). **(A)** As a first step to understand the genetic basis of appetitive olfactory learning, a synapsin null mutant (*syn^{97CS}*) is investigated in the individual animal version of the learning assay. Learning in *syn^{97CS}* is reduced to less than 50% of wild-type CS levels. **(A')** Repetition of the experiment using the en masse version of the assay; please note that, although the median LI is the same as in the individual animal version (A), scatter is much reduced. **(B–D)** Behavioral controls in experimentally naive larvae. Responses to the used odors and to the fructose (FRU) reward are not different between genotypes. **(E–H)** Behavioral controls after “sham training.” Sham-training procedures involve the same training procedure as shown in the inset of Figure 6A, except that either the reinforcer or the odors are omitted. After sham training, animals are tested for their ability to detect AM or OCT, respectively. In neither of the sham-training experiments is any difference between wild-type CS and *syn^{97CS}* uncovered. **(I, J)** Anti-synapsin (green) and anti-F-actin (magenta) immunoreactivity of whole-mount larval third instar brains viewed under the confocal microscope. Brains of wild-type CS (I) do, but brains of *syn^{97CS}* larvae do not show anti-synapsin staining. All behavioral experiments, except in A', use individually assayed larvae. Insets illustrate the behavioral procedure. *, $P < 0.05$; NS, $P > 0.05$: for comparisons of single groups against zero, one-sample sign tests are used; comparisons between any pair of groups are performed by Mann–Whitney U -tests. Other details as in the legend of Figure 4. Sample sizes for each box plot range from 30 (C) to 70 (B). From Michels et al. (2005, A–H); Cold Spring Harbor Laboratory Press (A–H) and Birgit Michels (I, J) as copyright holders kindly granted permission to use these figures.

gustatory capacity and thus their ability to establish odor–taste memories. However, it seems warranted to adopt additional sham-training controls for evaluating olfactory faculties as they are required to express memory during test.

A nonreciprocal training design: caveats and findings

A modified one-odor, one-trial olfactory learning experiment is introduced by Honjo and Furukubo-Tokunaga (2005). It uses a nonreciprocal training design, such that the experimental group receives a single 30-min training trial with the odor together with a liquid sugar reward, whereas 3 control groups receive 1) a 30-min exposure to only the odor; 2) a 30-min exposure to only the sugar reward; or 3) are tested naively, that is, after not receiving any exposure. After these kinds of treatment, the larvae are tested for their odor preference. For 2 out of the 3 tested odors (linalool: LIN and pentyl acetate: PA but not for γ -valerolactone: GVA), the trained group shows a higher odor preference than either of the 3 control groups. This increase in odor preference is stimulus specific, as larvae trained with LIN show an increased preference for LIN but not for PA, whereas for larvae trained with PA, an increased preference for PA but not for LIN is found. Concerning LIN, it is also shown that presenting LIN and the sugar reward on separate trials does not lead to an increased LIN preference. Together, these results argue that, at least for LIN, associative learning can indeed be measured in this paradigm. Consequently, the authors use LIN for a subsequent detailed account of the molecular and cellular underpinnings of behavior in this paradigm. Before reviewing these very timely series of experiments, however, one caveat may be considered.

To quantify associative learning, the authors calculate a normalized odor preference (range 1 to -1) of the trained group and subtract from it the preference of the odor-exposure control group (the resulting values thus range from 2 to -2 ; to be comparable with the learning index introduced above, which ranges 1 to -1 , these values thus need to be divided by 2; see legend of Figure 4D). To choose the odor-exposure control group, rather than either of the other control groups, is from a practical point of view unproblematic as long as all 3 kinds of control groups show the same odor preference. However, for all 3 odors tested, odor exposure reduces odor preference below that of experimentally naive animals (Honjo and Furukubo-Tokunaga 2005: loc. cit. Figure 2D for LIN, Figure 2B for PA, and Figure 2C for GVA); such reduction is a rather general finding after odor exposure (Cobb and Domain 2000; Wuttke and Tompkins 2000; Boyle and Cobb 2005; Michels et al. 2005; Colomb et al. forthcoming). Hence, the associative learning effect may be overestimated because odor preference is decreased in the odor-exposure control group independent of associative learning. Also, mutants may be altered in terms of the effects of odor exposure; thus, a weaker odor-exposure effect could feign a learning defect, or a stronger odor-exposure effect could obscure a learning defect. Finally, as the sugar

reward is applied in liquid form, larvae need to be carefully rinsed before the test to prevent any contamination of the test plate with the reinforcer that can substantially alter the behavioral expression of memory (Schroll et al. 2006); such effects may be particularly severe for tastants that leave a strong “bad taste,” such as bitter substances.

In any event, Honjo and Furukubo-Tokunaga (2005) test the usual suspect mutants for *rutabaga* (*rut*¹, *rut*²⁰⁸⁰), coding for the type I adenylate cyclase; *dunce* (*dnc*¹), coding for the corresponding esterase; and *amnesiac* (*amn*^{28A}), coding for a fly homologue of a vertebrate pituitary adenylate cyclase-activating peptide (Waddell and Quinn 2001). In adult flies, all these mutants have impaired olfactory memory scores (reviewed by Zars 2000; Waddell and Quinn 2001; Heisenberg 2003; Gerber, Tanimoto, et al. 2004; Davis 2005) and, as Honjo and Furukubo-Tokunaga (2005) now report, are also defective in the nonreciprocal larval training assay. For none of these mutants do odor preferences differ between the 3 kinds of control procedure, suggesting that the caveat discussed above does not apply for these particular mutants. Furthermore, responsiveness to the sugar as well as to LIN is not different from a wild-type strain, which is used as the genetic control for all 4 mutant strains. The authors also find that as early as 30–60 min after training, heat-shock-induced expression of a dominant-negative cAMP-responsive element-binding protein transgene (dCREB2-b) reduces the difference between the trained group and the odor-exposure control. Finally, if during testing the output of chemical synapses of the MBs is blocked by expressing *shibire*^{ts} (Kitamoto 2001) in the MB-specific drivers 201Y-*Gal4* and OK301-*Gal4*, the trained group and the odor-exposure control group behave indistinguishably. If, however, these synapses are blocked only during training, the trained group shows a higher odor preference than the odor-exposure control. The above-mentioned caveats concerning nonreciprocal training designs in mind, this suggests that, similar to the situation in adult flies (Heisenberg 2003; Gerber, Tanimoto, et al. 2004), output from the larval MB may be required during the retrieval of an olfactory memory trace, but not for its establishment.

“Remote control” of appetitive reinforcement

In addition to the question where a memory trace may be localized in the brain, one can ask how such a trace is established in the first place. One condition is the convergence of olfactory processing with an internal reinforcing signal. A reinforcing signal for appetitive olfactory learning in insects is mediated by octopaminergic neurons: In flies and crickets, octopamine signaling is necessary for appetitive odor learning, but not for aversive odor learning (Schwaerzel et al. 2003; Unoki et al. 2005). Furthermore, in honeybees local octopamine injections are sufficient to substitute for the sugar reward in odor–sugar learning (Hammer and Menzel 1998) and to “rescue” the learning defect in animals depleted of biogenic amines by reserpine (Menzel et al. 1999).

Similarly, feeding octopamine rescues the learning defect in octopamine-less mutant flies (Schwaerzel et al. 2003). Both in bees and in flies, presence of octopamine during training is sufficient to restore learning, whereas restitution of octopamine during only the test has no effect (Menzel et al. 1999; Schwaerzel et al. 2003).

With respect to the cellular substrate for these octopamine effects, the study of Hammer (1993) provides the hallmark: stimulation of a single, putatively octopaminergic (Kreissl et al. 1994), identified neuron (Vum_{mx1}) is sufficient to substitute for the reinforcing function of sugar in honeybee olfactory learning. To see whether activity of octopaminergic neurons in the *Drosophila* larva may also be sufficient to substitute for the sugar reward, Schroll et al. (2006) use a novel approach to noninvasively drive genetically defined sets of neurons. Using the *Gal4/UAS* system (Brand and Perrimon, 1993), the blue light-gated ion channel channelrhodopsin-2 is expressed under the control of the tyrosine decarboxylase promoter, leading to expression of channelrhodopsin-2 in octopaminergic/tyramineric cells. Due to the transparency of the larval cuticle, these cells can then be easily driven with fine temporal resolution (<1 s) by turning on the blue light. If such light stimulation is paired with an odor, and another odor is presented in darkness, the larvae will subsequently prefer the former odor (Figure 7B). Thus, light-induced activation of octopaminergic/tyramineric neurons is sufficient to substitute for reinforcement by sugar reward in larval appetitive olfactory learning. In turn, associatively driving dopaminergic neurons induces aversive learning (Figure 7D); in keeping with the results from Gerber and Hendel (forthcoming), the appetitive memory seen after associatively stimulating octopaminergic/tyramineric neurons is seen only in the absence of any reinforcer, whereas the dopamine-induced memory is seen only in the presence of an aversive reinforcer.

Thus, larval olfactory learning is similar to adults in terms of involvement of the same genes (*synapsin* and likely *rutabaga*, *dunce*, and *amnesiac*), the most likely site of a memory trace (the MBs), and the differential involvement of biogenic amines for appetitive and aversive learning (octopamine/tyramine and dopamine, respectively).

Visual learning and tests for across-modality interaction

As mentioned above, there also is a visual learning paradigm available, which hence allows testing for an interaction between olfactory and visual learning. In the case of visual learning, “light” and “dark” are used as to-be-learned stimuli. Light is applied from below using a “5’ light table” (VOLPI AG, Schlieren, Switzerland). Petri dishes are elevated 5 mm above the surface of the light table. To create “dark” regions, black cardboard is inserted 3 mm above the light source; to prevent heating up of the cardboards, they are covered with an aluminum shield from below.

Under these conditions, and in accordance with many earlier reports using slightly different methods (e.g., Hassan

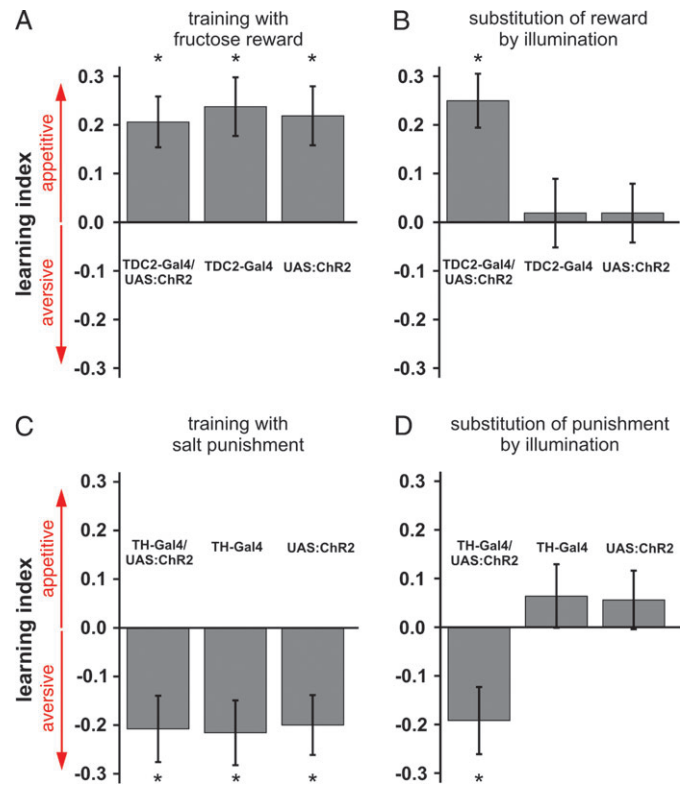

Figure 7 “Remote control” of associative reinforcement. **(A, C)** Experimental (leftmost bars) and control genotypes learn equally well when using “real” reinforcement (A: fructose, C: high-concentration NaCl). **(B, D)** If instead of providing the “real” reinforcement during training, light stimulation is used, only those larvae that express channelrhodopsin-2 in octopaminergic/tyramineric neurons (TDC2-Gal4/UAS:ChR2) show appetitive memory (B); the control strains carrying the *Gal4*-construct only (TDC2-Gal4) or the channelrhodopsin-2 construct only (UAS:ChR2) do not show any memory. Associatively driving channelrhodopsin-2 in dopaminergic neurons (TH-Gal4/UAS:ChR2) during training, in turn, substitutes for aversive reinforcement (D). Following Gerber and Hendel (forthcoming), appetitive memory scores are assayed in the absence of the appetitive reinforcer and aversive scores in the presence of the aversive reinforcer (see section “Effectiveness of reward, but not punishment?”). Shown are mean \pm standard error of mean. From Schroll et al. (2006). Elsevier as copyright holder kindly granted permission to use these figures.

et al. 2000), larvae show a moderate preference for dark over light. Thus, training is designed to up- or downregulate this moderate, innate dark preference. Using fructose as reward and either salt or quinine as punishment, dark preferences are higher after dark+/light- training than after dark-/light+ training (Gerber, Scherer, et al. 2004). As for olfactory learning, it is this difference in preference between the reciprocally trained groups that is indicative of associative learning. Learning can then be quantified by measuring this difference in preference in terms of a learning index. (This paradigm is now established also in the laboratory of M. Sokolowski, University of Toronto, Canada.)

Concerning a possible interaction between visual and olfactory associative processing (Yarali et al. 2006), it turns out that neither visual context influences odor learning

nor changes of visual context between training and test affect retrieval of odor memory. Furthermore, the same study reports that larvae cannot solve a biconditional discrimination task, despite explicit training and generally permissive conditions. In this task, larvae are required to establish conditional associations: in light, an odor is rewarded but another one is not, whereas in dark, the opposite contingency is established. After such training, choice between the odors is equal under light and dark testing conditions, suggesting that larvae cannot establish odor memories specifically for a given visual context only. Together, these data suggest that olfactory learning and memory is functionally separated from visual processing in larval *Drosophila*.

Synaptic plasticity

The availability of associative learning assays in the larva may help to bridge the gap between the behavioral and the synaptic level of biology. For an analysis of synaptic plasticity in *Drosophila*, typically the glutamatergic neuromuscular junction (NMJ) at the larval body wall is investigated (Jan LY and Jan YN 1976a, 1976b; recent reviews: Koh et al. 2000; Kidokoro et al. 2004). However, central brain synapses are most likely the ones responsible for associative learning also in the larva, and it is unknown whether mechanisms of plasticity discovered at the NMJ operate at the relevant central brain synapses as well. Still, the analyses of plasticity at the NMJ are the only ones we have and therefore are briefly discussed here to the extent that serious efforts were made to relate physiology to behavior.

Each of the 30 muscle fibers per abdominal hemisegment in the larva is innervated by 2–4 motor neurons. Their terminals are arranged as boutons, large swellings (up to 5 μm) comprising up to 40 presynaptic compartments each (individual active zones) and representing an ultrastructural specialization of the NMJ; however, the ultrastructural arrangement of individual active zones seems similar to the one in central brain synapses. The major excitatory transmitter at the NMJ is glutamate (Jan LY and Jan YN 1976b), whereas acetylcholine is the major central brain transmitter. This situation is inverted relative to vertebrates, where the major excitatory transmitter at the NMJ is acetylcholine, whereas the most prominent excitatory central brain transmitter is glutamate.

In an attempt to relate behavioral and synaptic plasticity, crawling behavior was chosen, which is a simple behavior that can be easily monitored and quantified (Sokolowski and Hansell 1983; Sokolowski et al. 1983; Wang et al. 1997). To use this behavior for an analysis of activity-dependent plasticity seems timely given that the morphology and physiology of NMJs change in hyperactive mutants such as *eag*, *Sh* (Budnik et al. 1990), and *Hk* (Stern and Ganetzky 1989). In addition, earlier data (Davis et al. 1996; Schuster et al. 1996a, 1996b) suggest that rearing conditions may be used to manipulate activity. Indeed, the

studies by Reiff et al. (2002) and Sigrist et al. (2003) suggest that elevated temperature causes enhanced crawling activity and use of the NMJ, which in turn causes growth of additional boutons and active zones, ultimately leading to a potentiation of muscle-to-nerve signal transmission. In a related study, Steinert et al. (2006) show that one mechanism underlying locomotor-induced potentiation is the generation of enlarged reserve-pool vesicles and their subsequent protein kinase A- and actin-dependent recruitment to the ready-releasable pool.

Outlook

The presented learning paradigms in larval *Drosophila* complement the accessibility of this system on the genetic, molecular, cellular, and physiological level. On the basis of the relatively detailed knowledge of the olfactory pathways of the larva and the emerging picture of peripheral and central gustatory processing, this should allow an integrated understanding of odor–taste learning. Such an understanding, as we think fascinating in itself, may be useful for the design of “intelligent” technical equipment, which may thus benefit from the cellular simplicity of the larval brain. By a combination of optical imaging, “remote control” of neuronal function, and the genetic techniques of single-cell expression of transgenes, it may in the longer run be possible to understand and model a complete associative learning network on the level of single, identified neurons.

Acknowledgements

Thanks to A. Eckart for the over-all assembly of Figure 1, P. Salvatore for providing Figure 1A, M. Wright for supply of Figure 1B, N. Gendre for compiling Figure 1C, to K. Neuser for providing Figure 1D and 1L, Vossahl for providing Figures 1I and 1J, L. Luo for providing Figure 1K, and to B. Michels for providing Figure 6I and 6J. We are grateful to J. Colomb, N. Gendre, M. Heisenberg, T. Hendel, C. Melcher, B. Michels, C. Schuster, S. Sigrist, and A. Yarali for comments on the manuscript and the production staff of OUP for patience. R.F.S. is supported by the Swiss National Fund (grants 31-63447.00, 3100A0-105517, and 3234-069273.02) and the Roche Research Foundation. B.G. was supported by a generous start-up grant from the Volkswagen Stiftung to initiate the larval learning project (grant I/76 240 to B.G.); current support comes from the Deutsche Forschungsgemeinschaft (DFG: SFB 554, GK 1156, Heisenberg Fellowship) and the German-Israeli Foundation for Scientific Research and Development (GIF: 1326-202.8/2003). Funding to pay the Open Access publication charges for this article was provided by Deutsche Forschungsgemeinschaft (DFG: SFB 554).

References

- Aceves-Pina EO, Quinn WG. 1979. Learning in normal and mutant *Drosophila* larvae. *Science*. 206:93–96.
- Ache BW, Young JM. 2005. Olfaction: diverse species, conserved principles. *Neuron*. 48:417–430.
- Armstrong JD, de Belle JS, Wang Z, Kaiser K. 1998. Metamorphosis of the mushroom bodies; large-scale rearrangements of the neural substrates for associative learning and memory in *Drosophila*. *Learn Mem*. 5:102–114.

- Benton R, Sachse S, Michnick SW, Vosshall LB. 2005. Atypical membrane topology and heteromeric function of *Drosophila* odorant receptors in vivo. *PLoS Biol.* 4(2):e20. doi: 10.1371.
- Bhalerao S, Sen A, Stocker RF, Rodrigues V. 2003. Olfactory neurons expressing identified receptor genes project to subsets of glomeruli within the antennal lobe of *Drosophila melanogaster*. *J Neurobiol.* 54:577–592.
- Boyle J, Cobb M. 2005. Olfactory coding in *Drosophila* larvae investigated by cross-adaptation. *J Exp Biol.* 208:3483–3491.
- Brand AH, Perrimon N. 1993. Targeted gene expression as a means of altering cell fates and generating dominant phenotypes. *Development.* 118:401–415.
- Buck L, Axel R. 1991. A novel multigene family may encode odorant receptors: a molecular basis for odor recognition. *Cell.* 65:175–187.
- Budnik V, Zhong Y, Wu CF. 1990. Morphological plasticity of motor axons in *Drosophila* mutants with altered excitability. *J Neurosci.* 10:3754–3768.
- Campos-Ortega JA, Hartenstein V. 1997. The embryonic development of *Drosophila melanogaster*. Berlin (Germany): Springer.
- Chen Q, He G, Qin W, Chen QY, Zhao XZ, Duan SW, Liu XM, Feng GY, Xu YF, St Clair D et al. 2004. Family-based association study of synapsin II and schizophrenia. *Am J Hum Genet.* 75:873–877.
- Chu IW, Axtell RC. 1971. Fine structure of the dorsal organ of the house fly larva, *Musca domestica* L. *Z Zellforsch Mikrosk Anat.* 117:17–34.
- Chu-Wang IW, Axtell RC. 1972a. Fine structure of the terminal organ of the house fly larva, *Musca domestica* L. *Z Zellforsch Mikrosk Anat.* 127:287–305.
- Chu-Wang IW, Axtell RC. 1972b. Fine structure of the ventral organ of the house fly larva, *Musca domestica* L. *Z Zellforsch Mikrosk Anat.* 130:489–495.
- Chyb S, Dahanukar A, Wickens A, Carlson JR. 2003. *Drosophila Gr5a* encodes a taste receptor tuned to trehalose. *Proc Natl Acad Sci USA.* 100:14526–14530.
- Clyne PJ, Warr CG, Carlson JR. 2000. Candidate taste receptors in *Drosophila*. *Science.* 287:1830–1834.
- Clyne PJ, Warr CG, Freeman MR, Lessing D, Kim J, Carlson JR. 1999. A novel family of divergent seven-transmembrane proteins: candidate odorant receptors in *Drosophila*. *Neuron.* 22:327–338.
- Cobb M. 1999. What and how do maggots smell? *Biol Rev.* 74:425–459.
- Cobb M, Domain I. 2000. Olfactory coding in a simple system: adaptation in *Drosophila* larvae. *Proc R Soc Lond B.* 267:2119–2125.
- Colomb J, Grillenzoni N, Stocker RF, Ramaekers A. Complex behavioral changes associated to odor exposure in *Drosophila* larvae. *Anim Behav.* Forthcoming.
- Couto A, Alenius M, Dickson BJ. 2005. Molecular, anatomical, and functional organization of the *Drosophila* olfactory system. *Curr Biol.* 15:1535–1547.
- Davis GW, Schuster CM, Goodman CS. 1996. Genetic dissection of structural and functional components of synaptic plasticity. III. CREB is necessary for presynaptic functional plasticity. *Neuron.* 17:669–679.
- Davis RL. 2005. Olfactory memory formation in *Drosophila*: from molecular to systems neuroscience. *Annu Rev Neurosci.* 28:275–302.
- de Belle JS, Heisenberg M. 1996. Expression of *Drosophila* mushroom body mutations in alternative genetic backgrounds: a case study of the mushroom body miniature gene (*mbm*). *Proc Natl Acad Sci (USA).* 93:9875–9880.
- Demerec M, Kaufmann BP. 1972. *Drosophila* guide. Introduction to the genetics and cytology of *Drosophila melanogaster*. Washington (DC): Carnegie Institution.
- Dickinson A. 2001. The 28th Bartlett memorial lecture: causal learning—an associative analysis. *Quart J Exp Psychol.* 54B:3–25.
- Diegelmann S, Zars M, Zars T. 2006. Genetic dissociation of acquisition and memory strength in the heat-box spatial learning paradigm in *Drosophila*. *Learn Mem.* 13:72–83.
- Dobritsa AA, van der Goes van Naters W, Warr CG, Steinbrecht RA, Carlson JR. 2003. Integrating the molecular and cellular basis of odor coding in the *Drosophila* antenna. *Neuron.* 37:827–841.
- Dukas, R. 1999. Ecological relevance of associative learning in fruit fly larvae. *Behav Ecol Sociobiol* 45:195–200.
- Dunipace L, Meister S, McNealy C, Amrein H. 2001. Spatially restricted expression of candidate taste receptors in the *Drosophila* gustatory system. *Curr Biol.* 11:822–835.
- Elsner B, Hommel B. 2001. Effect anticipation and action control. *J Exp Psychol Hum Percept Perform.* 27:229–240.
- Faucher C, Forstreuter M, Hilker M, de Bruyne M. 2006. Behavioral responses of *Drosophila* to biogenic levels of carbon dioxide depend on life-stage, sex and olfactory context. *J Exp Biol.* 209:2739–2748.
- Ferreira A, Rapoport M. 2002. The synapsins: beyond the regulation of neurotransmitter release. *Cell Mol Life Sci.* 59:589–595.
- Fiala A, Spall T, Diegelmann S, Eisermann B, Sachse S, Devaud JM, Buchner E, Galizia CG. 2002. Genetically expressed cameleon in *Drosophila melanogaster* is used to visualize olfactory information in projection neurons. *Curr Biol.* 12:1877–1884.
- Fishilevich E, Domingos AI, Asahina K, Naef F, Vosshall LB, Louis M. 2005. Chemotaxis behavior mediated by single larval olfactory neurons in *Drosophila*. *Curr Biol.* 15:2086–2096.
- Forbes B. 1993. Larval learning and memory in *Drosophila melanogaster* [Diploma Thesis]. University of Würzburg, Department of Genetics and Neurobiology.
- Frederick RD, Denell RE. 1982. Embryological origin of the antenno-maxillary complex of the larva of *Drosophila melanogaster* Meigen. *Int J Insect Morphol Embryol.* 11:227–233.
- Gao Q, Yuan B, Chess A. 2000. Convergent projections of *Drosophila* olfactory neurons to specific glomeruli in the antennal lobe. *Nat Neurosci.* 3:780–785.
- Garcia CC, Blair HJ, Seager M, Coulthard A, Tennant S, Buddles M, Curtis A, Goodship JA. 2004. Identification of a mutation in synapsin I, a synaptic vesicle protein, in a family with epilepsy. *J Med Genet.* 41:183–186.
- Gehring W, Seippel S. 1967. Die Imaginalzellen des Clypeo-Labrum und die Bildung des Rüssels von *Drosophila melanogaster*. *Rev Suisse Zool.* 74:589–596.
- Gendre N, Lüer K, Friche S, Grillenzoni N, Ramaekers A, Technau GM, Stocker RF. 2004. Integration of complex larval chemosensory organs into the adult nervous system of *Drosophila*. *Development.* 131:83–92.
- Gerber B, Hendel T. 2006. Outcome expectations drive learned behaviour in larval *Drosophila*. *Proc R Soc B.* doi: 10.1098/rspb.2006.3673.
- Gerber B, Scherer S, Neuser K, Michels B, Hendel T, Stocker RF, Heisenberg M. 2004. Visual learning in individually assayed *Drosophila* larvae. *J Exp Biol.* 207:179–188.
- Gerber B, Tanimoto H, Heisenberg M. 2004. An engram found? Evaluating the evidence from fruit flies. *Curr Opin Neurobiol.* 14:737–744.
- Gitler D, Takagishi Y, Feng J, Ren Y, Rodriguiz RM, Wetsel WC, Greengard P, Augustine GJ. 2004. Different presynaptic roles of synapsins at excitatory and inhibitory synapses. *J Neurosci.* 24:11368–11380.

- Godenschwege TA, Reisch D, Diegelmann S, Eberle K, Funk N, Heisenberg M, Hoppe V, Hoppe J, Klagges BRE, Martin JR et al. 2004. Flies lacking all synapsins are unexpectedly healthy but are impaired in complex behaviour. *Eur J Neurosci.* 20:611–622.
- Goldman AL, van der Goes van Naters W, Lessing D, Warr CG, Carlson JR. 2005. Coexpression of two functional odor receptors in one neuron. *Neuron.* 45:661–666.
- Hallem EA, Dahanukar A, Carlson JR. 2006. Insect odor and taste receptors. *Annu Rev Entomol.* 51:113–135.
- Hallem EA, Ho MG, Carlson JR. 2004. The molecular basis of odor coding in the *Drosophila* antenna. *Cell.* 117:965–979.
- Hammer M. 1993. An identified neuron mediates the unconditioned stimulus in associative olfactory learning in honeybees. *Nature.* 366:59–63.
- Hammer M, Menzel R. 1998. Multiple sites of associative odor learning as revealed by local brain microinjections of octopamine in honeybees. *Learn Mem.* 5:146–156.
- Hassan J, Busto M, Iyengar B, Campos AR. 2000. Behavioral characterization and genetic analysis of the *Drosophila melanogaster* larval response to light as revealed by a novel individual assay. *Behav Genetics.* 30:59–69.
- Heimbeck G, Bugnon V, Gendre N, Häberlin C, Stocker RF. 1999. Smell and taste perception in *D. melanogaster* larva: toxin expression studies in chemosensory neurons. *J Neurosci.* 19:6599–6609.
- Heisenberg M. 2003. Mushroom body memoir: from maps to models. *Nat Rev Neurosci.* 4:266–275.
- Heisenberg M, Borst A, Wagner S, Byers D. 1985. *Drosophila* mushroom body mutants are deficient in olfactory learning. *J Neurogenet.* 2:1–30.
- Helfrich-Förster C, Edwards T, Yasuyama K, Wisotzki B, Schneuwly S, Stanewsky R, Meinertzhagen IA, Hofbauer A. 2002. The extraretinal eyelet of *Drosophila*: development, ultrastructure, and putative circadian function. *J Neurosci.* 22:9255–9266.
- Hendel T, Michels B, Neuser K, Schipanski A, Kaun K, Sokolowski MB, Marohn F, Michel R, Heisenberg M, Gerber B. 2005. The carrot, not the stick: appetitive rather than aversive gustatory stimuli support associative olfactory learning in individually assayed *Drosophila* larvae. *J Comp Physiol A.* 191:265–279.
- Hildebrand JG, Shepherd G. 1997. Mechanisms of olfactory discrimination: converging evidence for common principles across phyla. *Annu Rev Neurosci.* 20:595–631.
- Hilfiker S, Pieribone VA, Czernik AJ, Kao H-T, Augustine GJ, Greengard P. 1999. Synapsins as regulators of neurotransmitter release. *Philos Trans R Soc B.* 354:269–279.
- Hoffmann J. 2003. Anticipatory behavioral control. In: Butz MV, Sigaud O, Gerad P, editors. *Anticipatory behavior in adaptive learning systems.* Heidelberg (Germany): Springer. p 44–65.
- Homberg U, Hildebrand JG. 1994. Postembryonic development of γ -aminobutyric acid-like immunoreactivity in the brain of the sphinx moth *Manduca sexta*. *J Comp Neurol.* 339:132–149.
- Honjo K, Furukubo-Tokunaga K. 2005. Induction of cAMP response element-binding protein-dependent medium-term memory by appetitive gustatory reinforcement in *Drosophila* larvae. *J Neurosci.* 25:7905–7913.
- Hummel T, Vasconcelos ML, Clemens JC, Fishilevich Y, Vosshall LB, Zipursky SL. 2003. Axonal targeting of olfactory receptor neurons in *Drosophila* is controlled by Dscam. *Neuron.* 37:221–231.
- Hummel T, Zipursky SL. 2004. Afferent induction of olfactory glomeruli requires N-cadherin. *Neuron.* 42:77–88.
- Itagaki H, Hildebrand JG. 1990. Olfactory interneurons in the brain of the larval sphinx moth *Manduca sexta*. *J Comp Physiol A.* 167:309–320.
- Ito M. 2001. Cerebellar long-term depression: characterization, signal transduction, and functional roles. *Physiol Rev.* 81:1143–1195.
- Jan LY, Jan YN. 1976a. Properties of the larval neuromuscular junction in *Drosophila melanogaster*. *J Physiol.* 262:189–214.
- Jan LY, Jan YN. 1976b. L-glutamate as an excitatory transmitter at the *Drosophila* larval neuromuscular junction. *J Physiol.* 262:215–236.
- Jefferis GSXE, Marin EC, Stocker RF, Luo L. 2001. Target neuron prespecification in the olfactory map of *Drosophila*. *Nature.* 414:204–208.
- Jefferis GSXE, Marin EC, Watts RJ, Luo L. 2002. Development of neuronal connectivity in *Drosophila* antennal lobes and mushroom bodies. *Curr Opin Neurobiol.* 12:80–86.
- Jefferis GSXE, Vyas RM, Berdnik D, Ramaekers A, Stocker RF, Tanaka NK, Ito K, Luo L. 2004. Developmental origin of wiring specificity in the olfactory system of *Drosophila*. *Development.* 131:117–130.
- Jhaveri D, Rodrigues V. 2002. Sensory neurons of the Atonal lineage pioneer the formation of glomeruli within the adult *Drosophila* olfactory lobe. *Development.* 129:1251–1260.
- Jhaveri D, Saharan S, Sen A, Rodrigues V. 2004. Positioning sensory terminals in the olfactory lobe of *Drosophila* by Robo signaling. *Development.* 131:1903–1912.
- Jhaveri D, Sen A, Rodrigues V. 2000. Mechanisms underlying olfactory neuronal connectivity in *Drosophila*—the atonal lineage organizes the periphery while sensory neurons and glia pattern the olfactory lobe. *Dev Biol.* 226:73–87.
- Kankel DR, Ferrus A, Garen SH, Harte PJ, Lewis PE. 1980. The structure and development of the nervous system. In: Ashburner M, Wright TRF, editors. *The genetics and biology of Drosophila.* London: Academic Press. p 295–368.
- Kent KS, Hoskins SG, Hildebrand JG. 1987. A novel serotonin-immunoreactive neuron in the antennal lobe of the sphinx moth *Manduca sexta* persists throughout postembryonic life. *J Neurobiol.* 18:451–465.
- Kidokoro Y, Kuromi H, Delgado R, Maureira C, Oliva C, Labarca P. 2004. Synaptic vesicle pools and plasticity of synaptic transmission at the *Drosophila* synapse. *Brain Res Rev.* 47:18–32.
- Kitamoto T. 2001. Conditional modification of behavior in *Drosophila* by targeted expression of a temperature-sensitive *shibire* allele in defined neurons. *J Neurobiol.* 47:81–92.
- Klagges B, Heimbeck G, Godenschwege TA, Hofbauer A, Pflugfelder GO, Reifegerste R, Reisch D, Schaupp M, Buchner S, Buchner E. 1996. Invertebrate synapsins: a single gene codes for several isoforms in *Drosophila*. *J Neurosci.* 16:3154–3165.
- Koh YH, Gramates LS, Budnik V. 2000. *Drosophila* larval neuromuscular junction: molecular components underlying synaptic plasticity. *Microsc Res Tech.* 49:14–25.
- Komiyama T, Carlson JR, Luo L. 2004. Olfactory receptor neuron axon targeting: intrinsic transcriptional control and hierarchical interactions. *Nat Neurosci.* 7:819–825.
- Kreher SA, Kwon AY, Carlson JR. 2005. The molecular basis of odor coding in the *Drosophila* larva. *Neuron.* 46:445–456.
- Kreissl S, Eichmüller S, Bicker G, Rapus J, Eckert M. 1994. Octopamine-like immunoreactivity in the brain and subesophageal ganglion of the honeybee. *J Comp Neurol.* 348:583–595.
- Kurusu M, Awasaki T, Masuda-Nakagawa LM, Kawauchi H, Ito K, Furukubo-Tokunaga K. 2002. Embryonic and larval development of the *Drosophila*

- mushroom bodies: concentric layer subdivisions and the role of fasciclin II. *Development*. 129:409–419.
- Laissue PP, Reiter C, Hiesinger PR, Halter S, Fischbach KF, Stocker RF. 1999. Three-dimensional reconstruction of the antennal lobe in *Drosophila melanogaster*. *J Comp Neurol*. 405:543–552.
- Larsson MC, Domingos AI, Jones WD, Chiappe ME, Amrein H, Vosshall LB. 2004. *Or83b* encodes a broadly expressed odorant receptor essential for *Drosophila* olfaction. *Neuron*. 43:703–714.
- Lee T, Lee A, Luo L. 1999. Development of the *Drosophila* mushroom bodies: sequential generation of three distinct types of neurons from a neuroblast. *Development*. 126:4065–4076.
- Lee T, Luo L. 1999. Mosaic analysis with a repressible cell marker for studies of gene function in neuronal morphogenesis. *Neuron*. 22:451–461.
- Lei H, Christensen TA, Hildebrand JG. 2004. Spatial and temporal organization of ensemble representations for different odor classes in the moth antennal lobe. *J Neurosci*. 24:11108–11119.
- Levine RB, Morton DB, Restifo LL. 1995. Remodeling of the insect nervous system. *Curr Opin Neurobiol*. 5:28–35.
- Liu L, Leonard AS, Motto DG, Feller MA, Price MP, Johnson WA, Welsh MJ. 2003. Contribution of *Drosophila* DEG/ENaC genes to salt taste. *Neuron*. 39:133–146.
- Liu L, Yermolaieva O, Johnson WA, Abboud FM, Welsh MJ. 2003. Identification and function of thermosensory neurons in *Drosophila* larvae. *Nat Neurosci*. 6:267–273.
- Malpel S, Klarsfeld A, Rouyer F. 2002. Larval optic nerve and adult extraretinal photoreceptors sequentially associate with clock neurons during *Drosophila* brain development. *Development*. 129:1443–1453.
- Marella S, Fischler W, Kong P, Asgarian S, Rueckert E, Scott K. 2006. Imaging taste responses in the fly brain reveals a functional map of taste category and behavior. *Neuron*. 49:285–295.
- Marin EC, Jefferis GSXE, Komiyama T, Zhu H, Luo L. 2002. Representation of the glomerular olfactory map in the *Drosophila* brain. *Cell*. 109:243–255.
- Marin EC, Watts RJ, Tanaka NK, Ito K, Luo L. 2005. Developmentally programmed remodeling of the *Drosophila* olfactory circuit. *Development*. 132:725–737.
- Masuda-Nakagawa LM, Tanaka NK, O’Kane CJ. 2005. Stereotypic and random patterns of connectivity in the larval mushroom body calyx of *Drosophila*. *Proc Natl Acad Sci USA*. 102:19027–19032.
- Melcher C, Pankratz MJ. 2005. Candidate gustatory interneurons modulating feeding behavior in the *Drosophila* brain. *PLoS Biol*. 3(9):e305.
- Menzel R, Heyne A, Kinzel C, Gerber B, Fiala A. 1999. Pharmacological dissociation between the reinforcing, sensitizing, and response-releasing functions of reward in honeybee classical conditioning. *Behav Neurosci*. 113:744–754.
- Michels B, Diegelmann S, Tanimoto H, Schwenkert I, Buchner E, Gerber B. 2005. A role of synapsin for associative learning: the *Drosophila* larva as a study case. *Learn Mem*. 12:224–231.
- Monte P, Woodard C, Ayer R, Lilly M, Sun H, Carlson JR. 1989. Characterization of the larval olfactory response in *Drosophila* and its genetic basis. *Behav Genet*. 19:267–283.
- Montmayeur JP, Matsunami H. 2002. Receptors for bitter and sweet taste. *Curr Opin Neurobiol*. 12:366–371.
- Neuhaus E, Gisselmann G, Zhang W, Dooley R, Störtkuhl K, Hatt H. 2004. Odorant receptor heterodimerization in the olfactory system of *Drosophila melanogaster*. *Nat Neurosci*. 8:15–17.
- Neuser K, Husse J, Stock P, Gerber B. 2005. Appetitive olfactory learning in *Drosophila* larvae: effects of repetition, reward strength, age, gender, assay type, and memory span. *Anim Behav*. 69:891–898.
- Ng M, Roorda RD, Lima SQ, Zemelman BV, Morcillo P, Miesenböck G. 2002. Transmission of olfactory information between three populations of neurons in the antennal lobe of the fly. *Neuron*. 36:463–474.
- Nowotny T, Huerta R, Abarbanel HDI, Rabinovich MI. 2005. Self-organization in the olfactory system: one shot odor recognition in insects. *Biol Cybern*. 93(6):436–446.
- Oland LA, Kirschenbaum SR, Pott WM, Mercer AR, Tolbert LP. 1995. Development of an identified serotonergic neuron in the antennal lobe of the moth and effects of reduction in serotonin during construction of olfactory glomeruli. *J Neurobiol*. 28:248–267.
- Opliger FY, Guerin PM, Vlimant M. 2000. Neurophysiological and behavioural evidence for an olfactory function for the dorsal organ and a gustatory one for the terminal organ in *Drosophila melanogaster* larvae. *J Insect Physiol*. 46:135–144.
- Pereanu W, Hartenstein V. 2006. Neural lineages of the *Drosophila* brain: a three-dimensional digital atlas of the pattern of lineage location and projection at the late larval stage. *J Neurosci*. 26:5534–5553.
- Perez-Orive J, Mazor O, Turner GC, Cassenaer S, Wilson RI, Laurent G. 2002. Oscillations and sparsening of odor representations in the mushroom body. *Science*. 297:359–365.
- Python F, Stocker RF. 2002a. Adult-like complexity of the larval antennal lobe of *D. melanogaster* despite markedly low numbers of odorant receptor neurons. *J Comp Neurol*. 445:374–387.
- Python F, Stocker RF. 2002b. Immunoreactivity against choline acetyltransferase, gamma-aminobutyric acid, histamine, octopamine, and serotonin in the larval chemosensory system of *Drosophila melanogaster*. *J Comp Neurol*. 453:157–167.
- Ramaekers A, Magnenat E, Marin EC, Gendre N, Jefferis GSXE, Luo L, Stocker RF. 2005. Glomerular maps without cellular redundancy at successive levels of the *Drosophila* larval olfactory circuit. *Curr Biol*. 15:982–992.
- Ray K, Hartenstein V, Rodrigues V. 1993. Development of the taste bristles on the labellum of *Drosophila melanogaster*. *Dev Biol*. 155:26–37.
- Ray K, Rodrigues V. 1994. The function of the proneural genes *achaete* and *scute* in the spatio-temporal patterning of the adult labellar bristles of *Drosophila melanogaster*. *Roux Arch Dev Biol*. 203:340–350.
- Reiff DF, Thiel PR, Schuster CM. 2002. Differential regulation of active zone density during long-term strengthening of *Drosophila* neuromuscular junctions. *J Neurosci*. 22:9399–9409.
- Ressler KJ, Sullivan SL, Buck LB. 1994. Information coding in the olfactory system: evidence for a stereotyped and highly organized epitope map in the olfactory bulb. *Cell*. 79:1245–1255.
- Robertson HM, Warr CG, Carlson JR. 2003. Molecular evolution of the insect chemoreceptor gene superfamily in *Drosophila melanogaster*. *Proc Natl Acad Sci USA*. 100:14537–14542.
- Rodrigues V. 1980. Olfactory behavior of *Drosophila melanogaster*. In: Siddiqi O, Babu P, Hall LM, Hall JC, editors. *Development and neurobiology of Drosophila*. New York: Plenum. p 361–371.
- Sachse S, Galizia CG. 2002. Role of inhibition for temporal and spatial odor representation in olfactory output neurons: a calcium imaging study. *J Neurophysiol*. 87:1106–1117.
- Scherer S, Stocker RF, Gerber B. 2003. Olfactory learning in individually assayed *Drosophila* larvae. *Learn Mem*. 10:217–225.

- Schmidt-Ott U, Gonzalez-Gaitan M, Jäckle H, Technau GM. 1994. Number, identity, and sequence of the *Drosophila* head segments as revealed by neural elements and their deletion patterns in mutants. *Proc Natl Acad Sci USA*. 91:8363–8367.
- Schroll C, Riemensperger T, Bucher D, Ehmer J, Voller T, Erbguth K, Gerber B, Hendel T, Nagel G, Buchner E, et al. 2006. Light-induced activation of distinct modulatory neurons triggers appetitive or aversive learning in *Drosophila* larvae. *Curr Biol*. 16:1741–1747.
- Schuster CM, Davis GW, Fetter RD, Goodman CS. 1996a. Genetic dissection of structural and functional components of synaptic plasticity. I. Fasciclin II controls synaptic stabilization and growth. *Neuron*. 17:641–654.
- Schuster CM, Davis GW, Fetter RD, Goodman CS. 1996b. Genetic dissection of structural and functional components of synaptic plasticity. II. Fasciclin II controls presynaptic structural plasticity. *Neuron*. 17:655–667.
- Schwaerzel M, Monastirioti M, Scholz H, Friggi-Grelin F, Birman S, Heisenberg M. 2003. Dopamine and octopamine differentiate between aversive and appetitive olfactory memories in *Drosophila*. *J Neurosci*. 23:10495–10502.
- Scott K, Brady R Jr, Cravchik A, Morozov P, Rzhetsky A, Zuker C, Axel R. 2001. A chemosensory gene family encoding candidate gustatory and olfactory receptors in *Drosophila*. *Cell*. 104:661–673.
- Sen AK, Shetty C, Jhaveri D, Rodrigues V. 2005. Distinct types of glial cells populate the *Drosophila* antenna. *BMC Dev Biol*. 5:25.
- Sengupta P, Chou JH, Bargmann CI. 1996. *odr-10* encodes a seven transmembrane domain olfactory receptor required for responses to the odorant diacetyl. *Cell*. 84:899–909.
- Sigrist SJ, Reiff DF, Thiel PR, Steinert JR, Schuster CM. 2003. Experience-dependent strengthening of *Drosophila* neuromuscular junctions. *J Neurosci*. 23:6546–6556.
- Singh RN. 1997. Neurobiology of the gustatory systems of *Drosophila* and some terrestrial insects. *Microsc Res Tech*. 39:547–563.
- Singh RN, Singh K. 1984. Fine structure of the sensory organs of *Drosophila melanogaster* Meigen Larva (Diptera: Drosophilidae). *Int J Insect Morphol Embryol*. 13:255–273.
- Sokolowski MB, Hansell RI. 1983. *Drosophila* larval foraging behavior. I. The sibling species, *D. melanogaster* and *D. simulans*. *Behav Genet*. 13:159–168.
- Sokolowski MB, Hansell RI, Rotin D. 1983. *Drosophila* larval foraging behavior. II. Selection in the sibling species, *D. melanogaster* and *D. simulans*. *Behav Genet*. 13:169–177.
- Steinert JR, Kuromi H, Hellwig A, Knirr M, Wyatt AW, Kidokoro Y, Schuster CM. 2006. Experience-dependent formation and recruitment of large vesicles from reserve pool. *Neuron*. 50:723–733.
- Stern M, Ganetzky B. 1989. Altered synaptic transmission in *Drosophila hyperkinetic* mutants. *J Neurogenet*. 5:215–228.
- Stocker RF. 1994. The organization of the chemosensory system in *Drosophila melanogaster*: a review. *Cell Tissue Res*. 275:3–26.
- Stocker RF. 2001. *Drosophila* as a focus in olfactory research: mapping of olfactory sensilla by fine structure, odor specificity, odorant receptor expression and central connectivity. *Microsc Res Tech*. 55:284–296.
- Stocker RF. Design of the larval chemosensory system. In: Technau GM, editor. *Brain development in Drosophila*. Georgetown (TX): Landes Bioscience. Forthcoming.
- Stocker RF, Heimbeck G, Gendre N, de Belle JS. 1997. Neuroblast ablation in *Drosophila* P[GAL4] lines reveals origins of olfactory interneurons. *J Neurobiol*. 32:443–456.
- Stocker RF, Schorderet M. 1981. Cobalt filling of sensory projections from internal and external mouthparts in *Drosophila*. *Cell Tissue Res*. 216:513–523.
- Strausfeld NJ, Hildebrand JG. 1999. Olfactory systems: common design, uncommon origins? *Curr Opin Neurobiol*. 9:634–639.
- Struhl G. 1981. A blastoderm fate map of compartments and segments of the *Drosophila* head. *Dev Biol*. 84:386–396.
- Sudhof T. 2004. The synaptic vesicle cycle. *Annu Rev Neurosci*. 27:487–507.
- Suh GSB, Wong AM, Hergarden AC, Wang JW, Simon AF, Benzer S, Axel R, Anderson DJ. 2004. A single population of olfactory sensory neurons mediates an innate avoidance behavior in *Drosophila*. *Nature*. 431:854–859.
- Sun B, Xu P, Salvaterra PM. 1999. Dynamic visualization of nervous system in live *Drosophila*. *Proc Natl Acad Sci USA*. 96:10438–10443.
- Tanaka NK, Awasaki T, Shimada T, Ito K. 2004. Integration of chemosensory pathways in the *Drosophila* second-order olfactory centers. *Curr Biol*. 14:449–457.
- Technau GM. 1986. Lineage analysis of transplanted individual cells in embryos of *Drosophila melanogaster*. I. The method. *Roux Arch Dev Biol*. 195:389–398.
- Technau GM, Heisenberg M. 1982. Neural reorganization during metamorphosis of the corpora pedunculata in *Drosophila melanogaster*. *Nature*. 295:405–407.
- Thorne N, Chromey C, Bray S, Amrein H. 2004. Taste perception and coding in *Drosophila*. *Curr Biol*. 14:1065–1079.
- Tissot M, Gendre N, Hawken A, Störtkuhl KF, Stocker RF. 1997. Larval chemosensory projections and invasion of adult afferents in the antennal lobe of *Drosophila melanogaster*. *J Neurobiol*. 32:281–297.
- Tissot M, Stocker RF. 2000. Metamorphosis in *Drosophila* and other insects: the fate of neurons throughout the stages. *Prog Neurobiol*. 62:89–111.
- Troemel ER, Chou JH, Dwyer ND, Colbert HA, Bargmann CI. 1995. Divergent seven transmembrane receptors are candidate chemosensory receptors in *C. elegans*. *Cell*. 83:207–218.
- Truman JW. 1996. Metamorphosis of the insect nervous system. In: Gilbert LI, Tata JR, Atkinson BG, editors. *Metamorphosis: postembryonic reprogramming of gene expression in amphibian and insect cells*. San Diego (CA): Academic Press. p 283–320.
- Tully T, Cambiazo V, Kruse L. 1994. Memory through metamorphosis in normal and mutant *Drosophila*. *J Neurosci*. 14:68–74.
- Unoki S, Matsumoto Y, Mizunami M. 2005. Participation of octopaminergic reward system and dopaminergic punishment system in insect olfactory learning revealed by pharmacological study. *Eur J Neurosci*. 22:1409–1416.
- Usui-Ishihara A, Simpson P, Usui K. 2000. Larval multidendrite neurons survive metamorphosis and participate in the formation of imaginal sensory axonal pathways in the notum of *Drosophila*. *Dev Biol*. 225:357–369.
- Vassar R, Chao SK, Sitcheran R, Nunez JM, Vosshall LB, Axel R. 1994. Topographic organization of sensory projections to the olfactory bulb. *Cell*. 79:981–991.
- Vosshall LB, Amrein H, Morozov PS, Rzhetsky A, Axel R. 1999. A spatial map of olfactory receptor expression in the *Drosophila* antenna. *Cell*. 96:725–736.
- Vosshall LB, Wong AM, Axel R. 2000. An olfactory sensory map in the fly brain. *Cell*. 102:147–159.
- Waddell S, Quinn WG. 2001. Flies, genes and learning. *Annu Rev Neurosci*. 24:1283–1309.

- Wang JW, Sylwester AW, Reed D, Wu D-AJ, Soll DR, Wu C-F. 1997. Morphometric description of the wandering behavior in *Drosophila* larvae: aberrant locomotion in Na⁺ and K⁺ channel mutants revealed by computer-assisted motion analysis. *J Neurogenet.* 11:231–254.
- Wang JW, Wong AM, Flores J, Vosshall LB, Axel R. 2003. Two-photon calcium imaging reveals an odor-evoked map of activity in the fly brain. *Cell.* 112:271–282.
- Wang Y, Guo HF, Pologruto TA, Hannan F, Hakker I, Svoboda K, Zhong Y. 2004. Stereotyped odor-evoked activity in the mushroom body of *Drosophila* revealed by green fluorescent protein-based Ca²⁺ imaging. *J Neurosci.* 24:6507–6514.
- Wang Z, Singhvi A, Kong P, Scott K. 2004. Taste representations in the *Drosophila* brain. *Cell.* 117:981–991.
- Williams DW, Shepherd D. 2002. Persistent larval sensory neurones are required for the normal development of the adult sensory afferent projections in *Drosophila*. *Development.* 129:617–624.
- Wilson RI, Laurent G. 2005. Role of GABAergic inhibition in shaping odor-evoked spatiotemporal patterns in the *Drosophila* antennal lobe. *J Neurosci.* 25:9069–9079.
- Wilson RI, Turner GC, Laurent G. 2004. Transformation of olfactory representations in the *Drosophila* antennal lobe. *Science.* 30:366–370.
- Wong AM, Wang JW, Axel R. 2002. Spatial representation of the glomerular map in the *Drosophila* protocerebrum. *Cell.* 109:229–241.
- Wuttke MS, Tompkins L. 2000. Olfactory adaptation in *Drosophila* larvae. *J Neurogenet.* 14:43–62.
- Yarali T, Hendel B, Gerber B. 2006. Olfactory learning and behaviour are ‘insulated’ against visual processing in larval *Drosophila*. *J Comp Physiol A.* 192:1133–1145.
- Yasuyama K, Meinertzhagen IA, Schürmann FW. 2002. Synaptic organization of the mushroom body calyx in *Drosophila melanogaster*. *J Comp Neurol.* 445:211–226.
- Yu D, Ponomarev A, Davis RL. 2004. Altered representation of the spatial code for odors after olfactory classical conditioning: memory trace formation by synaptic recruitment. *Neuron.* 42:437–449.
- Zars T. 2000. Behavioral functions of the insect mushroom bodies. *Curr Opin Neurobiol.* 10:790–795.
- Zhang SD, Odenwald WF. 1995. Misexpression of the *white* gene triggers male-male courtship in *Drosophila*. *Proc Natl Acad Sci USA.* 92:5525–5529.

Accepted August 25, 2006