



# Collateral-flow measurements in humans by myocardial contrast echocardiography: validation of coronary pressure-derived collateral-flow assessment

Rolf Vogel, Rainer Zbinden, Andreas Indermühle, Stephan Windecker, Bernhard Meier, and Christian Seiler\*

Department of Cardiology, University Hospital Bern, CH-3010 Bern, Switzerland

Received 13 June 2005; revised 28 July 2005; accepted 22 September 2005; online publish-ahead-of-print 5 October 2005

See page 123 for the editorial comment on this article (doi:10.1093/eurheartj/ehi640)

## KEYWORDS

Coronary circulation;  
Collateral circulation;  
Collateral flow index;  
Myocardial blood flow;  
Myocardial perfusion;  
Myocardial contrast  
echocardiography

**Aims** Myocardial blood flow (MBF) is the gold standard to assess myocardial blood supply and, as recently shown, can be obtained by myocardial contrast echocardiography (MCE). The aims of this human study are (i) to test whether measurements of collateral-derived MBF by MCE are feasible during elective angioplasty and (ii) to validate the concept of pressure-derived collateral-flow assessment.

**Methods and results** Thirty patients with stable coronary artery disease underwent MCE of the collateral-receiving territory during and after angioplasty of 37 stenoses. MCE perfusion analysis was successful in 32 cases. MBF during and after angioplasty varied between 0.060–0.876 mL min<sup>-1</sup> g<sup>-1</sup> (0.304 ± 0.196 mL min<sup>-1</sup> g<sup>-1</sup>) and 0.676–1.773 mL min<sup>-1</sup> g<sup>-1</sup> (1.207 ± 0.327 mL min<sup>-1</sup> g<sup>-1</sup>), respectively. Collateral-perfusion index (CPI) is defined as the rate of MBF during and after angioplasty varied between 0.05 and 0.67 (0.26 ± 0.15). During angioplasty, simultaneous measurements of mean aortic pressure, coronary wedge pressure, and central venous pressure determined the pressure-derived collateral-flow index (CFI<sub>p</sub>), which varied between 0.04 and 0.61 (0.23 ± 0.14). Linear-regression analysis demonstrated an excellent agreement between CFI<sub>p</sub> and CPI ( $y = 0.88x + 0.01$ ;  $r^2 = 0.92$ ;  $P < 0.0001$ ).

**Conclusion** Collateral-derived MBF measurements by MCE during angioplasty are feasible and proved that the pressure-derived CFI exactly reflects collateral relative to normal myocardial perfusion in humans.

## Introduction

The coronary collateral circulation constitutes an alternative blood supply to myocardium jeopardized by ischaemia, and its protective role has been demonstrated by numerous investigations.<sup>1</sup> Of considerable clinical relevance, coronary collateral arteries have become a target for novel treatment strategies by therapeutic arteriogenesis in patients with severe coronary artery disease (CAD).<sup>2–4</sup> In order to demonstrate the efficacy of pro-arteriogenic substances, it is indispensable to quantitatively assess collateral flow, which in turn entails selective delineation of collateral pathways. The first technique fulfilling these requirements used coronary pressure measurements distal to a stenosis during angioplasty, i.e. coronary wedge pressure, which was related to angiographically visible collaterals.<sup>5</sup> The current reference method measures collateral flow as a fraction of normal flow using a collateral-flow index (CFI), which is derived from simultaneous measurements of mean aortic pressure, coronary wedge pressure, and central venous

pressure (CVP) during angioplasty. This CFI is theoretically well defined<sup>6</sup> and has been confirmed by several invasive studies.<sup>7–9</sup> Moreover, Matsuo *et al.*<sup>10</sup> validated the index against perfusion defects, using <sup>99m</sup>Tc-sestamibi during angioplasty. However, the direct verification of the CFI vs. the gold standard of myocardial blood supply assessment, that is, myocardial blood flow (MBF) (mL min<sup>-1</sup> g<sup>-1</sup>), is still lacking. MBF, defined as blood flow (mL min<sup>-1</sup>) into a region relative to its mass (g), can be obtained by positron emission tomography and lately by myocardial contrast echocardiography (MCE).<sup>11</sup>

The objectives of this human study are (i) to demonstrate that collateral-derived MBF can be obtained by MCE during elective angioplasty and (ii) to validate the concept of pressure-derived collateral-flow assessment by simultaneous measurements of coronary pressure and MBF.

## Methods

### Angioplasty model

Figure 1 depicts the flow model consisting of a myocardial area that is supplied by a stenotic coronary artery and an alternative pathway representing coronary collaterals. The biophysical properties of the

\* Corresponding author. Tel: +41 31 6323693; fax: +41 31 6324299.  
E-mail address: christian.seiler.cardio@insel.ch

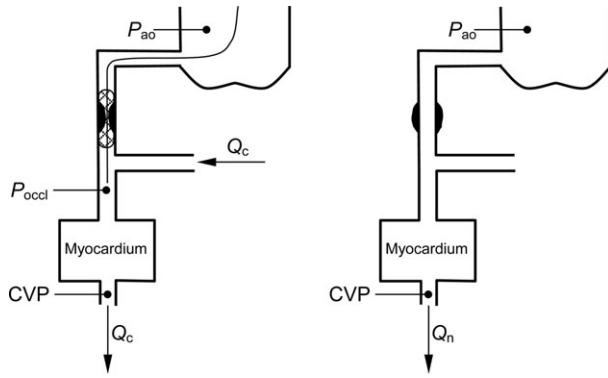

**Figure 1** Schematic model representing the coronary circulation during (left panel) and after successful angioplasty (right panel). The guidewire is equipped with a pressure sensor at its tip distal to the stenosis.

myocardium are characterized by its flow resistance ( $R_{myo}$ , mmHg min mL<sup>-1</sup>) and mass ( $m_{myo}$ , g). The collateral-perfusion index (CPI, 1) is defined as collateral-derived MBF (MBF<sub>c</sub>, mL min<sup>-1</sup> g<sup>-1</sup>) during balloon occlusion (left-hand panel) relative to normal MBF (MBF<sub>n</sub>, mL min<sup>-1</sup> g<sup>-1</sup>) after removal of the stenosis (right-hand panel):

$$CPI = \frac{MBF_c}{MBF_n} = \frac{Q_c/m_{myo}}{Q_n/m_{myo}} = \frac{Q_c}{Q_n}. \quad (1)$$

Collateral-derived flow ( $Q_c$ , mL min<sup>-1</sup>) and normal coronary flow ( $Q_n$ , mL min<sup>-1</sup>) are controlled by their perfusion pressure, i.e. coronary wedge pressure ( $P_{occl}$ , mmHg) during angioplasty and aortic pressure ( $P_{ao}$ , mmHg) after successful angioplasty, and the CVP (mmHg), which acts as backpressure:

$$Q_c = \frac{P_{occl} - CVP}{R_{myo}} \quad (2)$$

and

$$Q_n = \frac{P_{ao} - CVP}{R_{myo}}. \quad (3)$$

The pressure-derived CFI (CFI<sub>p</sub>, 1) equals:

$$CFI_p = \frac{P_{occl} - CVP}{P_{ao} - CVP} = \frac{Q_c}{Q_n} = CPI. \quad (4)$$

## Study population and protocol

For this pilot study, we planned to investigate 30 patients with stable CAD eligible for percutaneous coronary intervention (PCI) of  $\geq 1$  stenotic lesion. Forty-four consecutive patients ( $\geq 18$  years) referred for elective coronary angiography were initially evaluated to participate in the study. Six patients refused consent and eight patients were excluded after the angiographic assessment. The patients were not screened for echocardiographic image quality and maintained their routine medication.

All measurements were performed in the catheterization laboratory during one session with the patient in supine position lying on his back. After diagnostic coronary angiography, constant venous ultrasound contrast agent (UCA) infusion was started and the myocardial territory of the coronary artery undergoing angioplasty, i.e. the collateral-receiving artery, was imaged by transthoracic MCE. PCI was performed after stable myocardial enhancement was reached. During balloon occlusion, myocardial perfusion sequences were captured while continuously recording coronary wedge pressure, aortic pressure, and CVP. After successful completion of the intervention, that is, restoration of normal blood flow at rest, perfusion imaging of the same territory was repeated following cessation of reactive hyperaemia. MCE and pressure studies were performed and analysed by two independent

examiners blinded to the other methods' results. The study protocol was approved by the Ethics Committee of the University of Bern, and all participants gave written informed consent to participate in the study.

## Cardiac catheterization and pressure measurements

After two puffs of isosorbide dinitrate, diagnostic coronary angiography was performed via the right femoral artery approach, using five French Judkins catheters. Indication for *ad hoc* PCI is based on the visual estimate of the stenosis per cent diameter reduction. For PCI and coronary pressure measurements, a six French-guiding catheter and a 0.014 in. guidewire equipped with a pressure sensor at the tip (PressureWire, RADI Medical, Uppsala, Sweden) was used. Simultaneous measurements of mean aortic pressure through the angioplasty-guiding catheter, coronary wedge pressure distal to the stenosis undergoing PCI, and CVP via a femoral venous access were performed during balloon occlusion. Stenosis severity was quantitatively assessed offline as per cent diameter reduction of the vessel (Philips DA, Best, The Netherlands).

## Myocardial contrast echocardiography

### Ultrasound contrast agent

UCA was administered via the right cubital vein, using parallel infusion of FS069 (OPTISON, Amersham Health SA, Oslo, Norway) 3 mL at a rate of 10–30 mL h<sup>-1</sup> (Perfusor fm, B. Braun Melsungen AG, Melsungen, Germany) and physiological saline at a rate of 400 mL h<sup>-1</sup> (VOLUMED®  $\alpha$ VP2001, arcomed ag, Regensdorf, Switzerland). The UCA infusion pump was manually agitated to guarantee UCA homogenization.

### Data acquisition

Transthoracic imaging was performed with an Acuson Sequoia C256 ultrasound scanner (Siemens Medical Solutions, Mountain View, CA, USA) equipped with a 3V2c transducer and Coherent Contrast Imaging®. Settings were as follows: MI for microsphere detection 0.08, MI for microsphere destruction 1.3, dynamic range 60 dB, and linear post-processing. The image plane was adjusted to the myocardial territory of the coronary artery to be dilated, i.e. the collateral-receiving territory. Gain was adjusted for optimal visualization of the myocardium and held constant throughout the image acquisition. Destruction-refill sequences were generated using the manual bubble destruction (MBD) feature of the scanner and recorded digitally for offline image analysis. The clip length was set to 200 frames with a triggered interval of 75 ms, resulting an acquisition time of 15 s. Prior to MBD, two cardiac cycles were captured for the calculation of the relative blood volume.

### Data analysis

Image visualization and quantification was done with DataPro 2.11 (Noesis S.A., Courtaboeuf, France). Logarithmic signal compression was removed, and linearized signal intensity data were expressed in arbitrary units. Quantitative perfusion analysis was performed on end-systolic frames selected from the perfusion sequence. Appropriate regions of interest were placed and tracked manually within the myocardium and an adjacent region within the left ventricular cavity.<sup>11</sup> Myocardial intensity data were corrected for non-contrast signals arising from the tissue by subtracting the signal intensity of the first frame after MBD. Myocardial plateau intensity  $A$  was calculated by averaging myocardial signal intensity data from frames before MBD (Figure 2). Parameter  $\beta$  (min<sup>-1</sup>) was derived from the fitting of myocardial intensity data after MBD to the refill equation [Eq. (5)].

$$y(t) = A \cdot (1 - e^{-\beta \cdot t}). \quad (5)$$

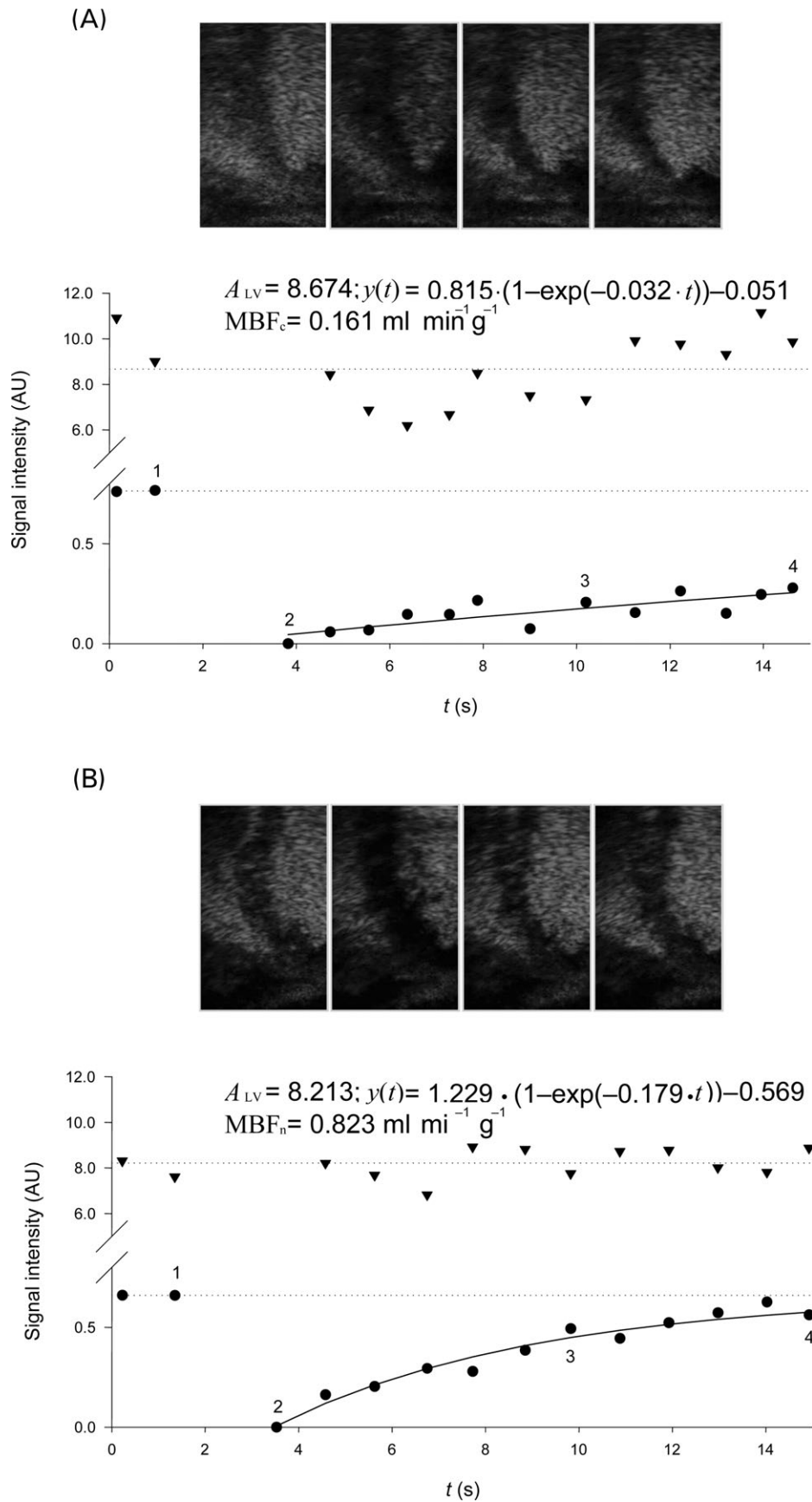

**Figure 2** Perfusion sequence and analysis of the interventricular septum recorded from the apical four-chamber view during (A) and after angioplasty (B). The numbers 1-4 within the refill curves indicate frame numbers from left to right. Left ventricular (▼) and myocardial (●) signal intensities of the mid-segment are plotted against time. Upper and lower dotted lines indicate mean left ventricular signal intensity  $A_{LV}$  and myocardial plateau signal intensity  $A$ , respectively.

Averaging left ventricular signal intensity data of all but the frames during and the first one after MBD yielded  $A_{LV}$  and the relative blood volume (rBV, mL mL<sup>-1</sup>):

$$rBV = \frac{A}{A_{LV}}. \quad (6)$$

MBF was calculated according to Eq. (7) with a tissue density  $\rho_T$  of 1.05 g mL<sup>-1</sup>:

$$MBF = \frac{rBV \cdot \beta}{\rho_T}. \quad (7)$$

## Statistical methods

Demographic and clinical data were expressed as mean  $\pm$  SD. Paired, two-sided *t*-tests were used for the comparison of pressure and perfusion data. Correlations were performed using linear-regression analysis, and the accuracy of the prediction was measured by the standard error of the estimate. Statistical significance was defined at a probability value  $P < 0.05$ . The Bonferroni correction was used for multiple comparisons between CPI and the pressure indices  $P_{occl}/P_{ao}$  and  $CFI_p$ . Agreement between two measurement techniques was established using Bland-Altman analysis by plotting the differences between the two techniques against the mean values of the two techniques; values of mean  $\pm$  2SD of measurement differences were added to the plots. The range within which the measurement differences were required to lie was not pre-defined.

## Results

The past medical history of the 30 patients revealed stable angina in 25 cases. *Table 1* summarizes patient's characteristics and angiographic data. Left ventricular ejection fraction and end-diastolic pressure (LVEDP) ranged between 30 and 70% and 3 and 1 mmHg, respectively. PCI was performed in 37 stenotic coronary arteries. The per cent diameter reduction ranged between 30 and 100%, including seven non-significant stenoses. Angioplasty of non-significant stenoses was performed because of visual overestimation in six cases (41–49% diameter reduction by quantitative analysis) and because of an ulcerated plaque in one case (30% diameter reduction). During angioplasty of 37 stenoses,

angina was present in 19 and ST-segment changes on the surface ECG in 20 cases. Invasive pressure measurements were obtained from all lesions (*Table 2*). MCE perfusion analysis during and after angioplasty was completed in 32 territories (*Table 2*) and failed in one lateral and four inferior territories. The causes for unsuccessful data acquisition of the four inferior territories were premature study termination due to an intervention-related serious adverse event in one patient, technical problems in two cases (scanner dysfunction and lack of synchronicity between sonographer and interventionalist), and poor image quality in one patient with severe chronic obstructive pulmonary disease.

*Figure 2* summarizes perfusion sequences and analyses during and after PCI of a left anterior descending coronary artery stenosis with a 52% diameter reduction and a pressure-derived CFI of 0.17. Visual comparison of the perfusion sequences suggests modest collateralization indicated by decelerated UCA refill during balloon inflation. MBF during and after successful angioplasty was 0.161 mL min<sup>-1</sup>g<sup>-1</sup> and 0.823 mL min<sup>-1</sup>g<sup>-1</sup>, respectively, resulting in a CPI of 0.20. Although relative myocardial blood volumes during and after PCI were similar (0.088 mL mL<sup>-1</sup> vs. 0.080 mL mL<sup>-1</sup>), the corresponding blood volume exchange frequency  $\beta$  increased from 1.920 to 10.740 min<sup>-1</sup>.

The graphical and statistical analyses of absolute ( $P_{occl}$ ,  $P_{occl}$ -CVP) and relative ( $P_{occl}/P_{ao}$ ,  $CFI_p$ ) pressure data vs. absolute (MBF<sub>c</sub>) and relative (CPI) perfusion data are shown in *Figures 3* and *4*, respectively. Coronary wedge pressure, effective coronary perfusion pressure ( $P_{occl}$ -CVP), coronary wedge pressure relative to aortic pressure ( $P_{occl}/P_{ao}$ ) as well as CFI,  $CFI_p$ , correlated linearly with absolute collateral-derived myocardial perfusion, and collateral-derived relative to normal myocardial perfusion. In accordance with the theoretical concept, the best agreement was found between pressure-derived CFI and CPI.

The measurement differences between non-dimensional collateral-pressure and -perfusion indexes, i.e.  $P_{occl}/P_{ao}$ ,  $CFI_p$ , and CPI, are depicted in *Figure 5*. Averaged over the entire range, the CPI was overestimated by  $P_{occl}/P_{ao}$  ( $0.030 \pm 0.053$ ,  $P = 0.003$ ) and underestimated by  $CFI_p$  ( $0.023 \pm 0.045$ ,  $P = 0.007$ ). Bland-Altman plots suggest proportional errors between  $P_{occl}/P_{ao}$  and CPI (*Figure 5A*) as well as, but less apparently, between  $CFI_p$  and CPI (*Figure 5B*).

**Table 1** Patient characteristics

Patients (women)	30 (5) <sup>a</sup>
Age (years)	64 $\pm$ 13
Body mass index (kg m <sup>-2</sup> )	29 $\pm$ 4
Heart rate (min <sup>-1</sup> )	72 $\pm$ 13
Mean blood pressure (mmHg)	96 $\pm$ 11
Left ventricular ejection fraction (%)	60 $\pm$ 11
Stenosis severity (per cent diameter stenosis)	72 $\pm$ 21
Distribution of stenoses	
< 50%	7 <sup>b</sup>
$\geq$ 50 to < 70%	10 <sup>b</sup>
$\geq$ 70 to < 90%	9 <sup>b</sup>
$\geq$ 90	11 <sup>b</sup>
1/2/3 vessel disease, respectively	7/14/9 <sup>a</sup>
PCI of stenosis	
Left anterior descending coronary artery	15 <sup>b</sup>
Left circumflex coronary artery	12 <sup>b</sup>
Right coronary artery	10 <sup>b</sup>

Values are mean  $\pm$  SD or number.

<sup>a</sup>Number indicates patients.

<sup>b</sup>Number indicates stenoses.

**Table 2** Pressure and perfusion data

	<i>n</i>	Mean $\pm$ SD	Range
$P_{ao}$ (mmHg)	37	94.4 $\pm$ 12.4	64.0–117.5
$P_{occl}$ (mmHg)	37	26.7 $\pm$ 11.7	9.0–57.3
CVP (mmHg)	37	6.6 $\pm$ 3.0	1.0–13.1
LVEDP (mmHg)	37	11 $\pm$ 7	3.0–31.0
$P_{occl}$ – CVP (mmHg)	37	20.1 $\pm$ 12.6	3.2–53.3
$P_{occl}/P_{ao}$ (1)	37	0.29 $\pm$ 0.13	0.09–0.62
$CFI_p$ (1)	37	0.23 $\pm$ 0.14	0.04–0.61
MBF <sub>c</sub> (mL min <sup>-1</sup> g <sup>-1</sup> )	33	0.304 $\pm$ 0.196	0.060–0.876
MBF <sub>n</sub> (mL min <sup>-1</sup> g <sup>-1</sup> )	32	1.207 $\pm$ 0.327	0.676–1.773
CPI (1)	32	0.26 $\pm$ 0.15	0.05–0.67

*n*, number of successfully assessed stenosis or territories.

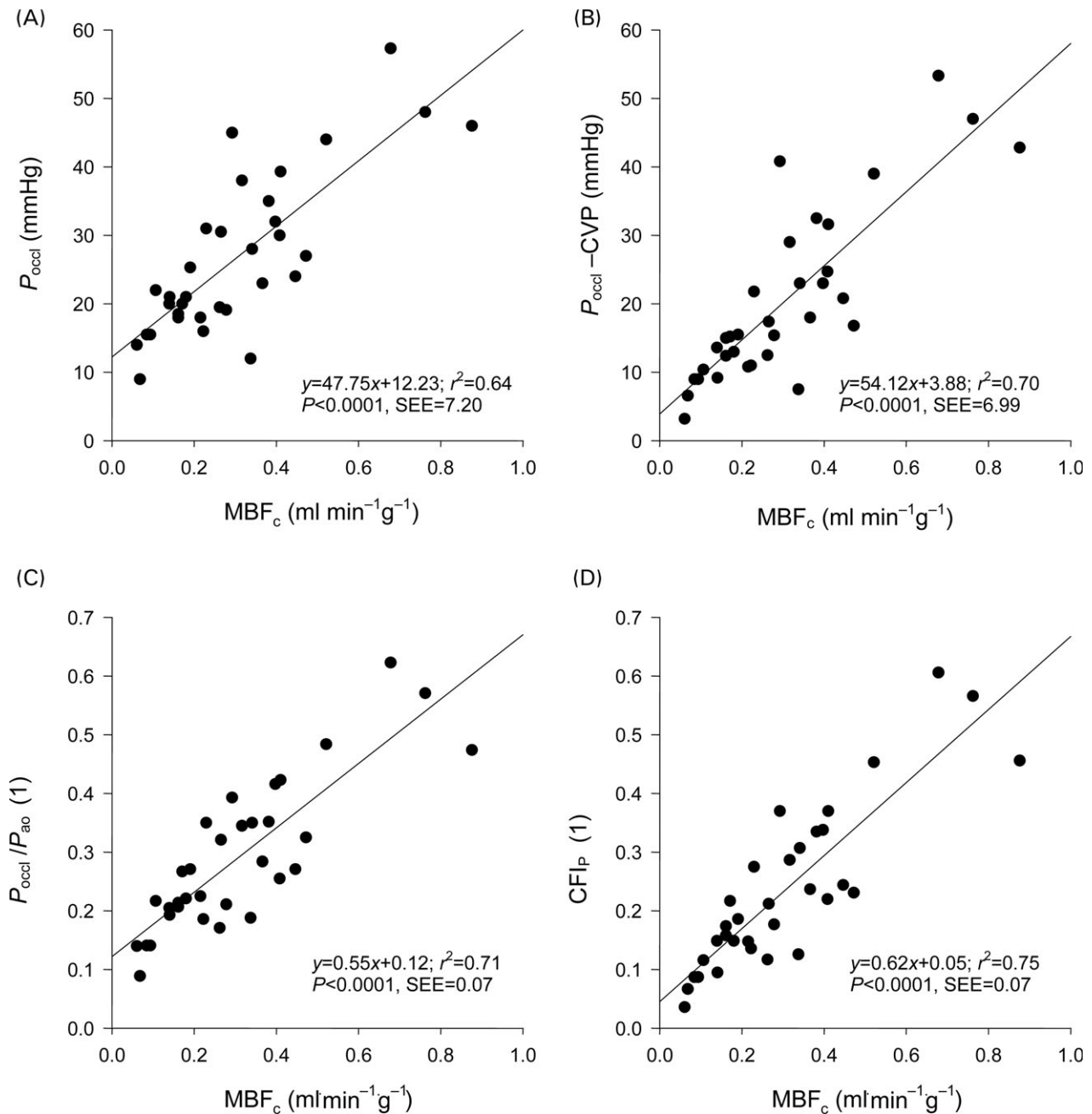

**Figure 3** Linear-regression analysis of pressure-derived collateral data ( $P_{occl}$ ,  $P_{occl}-CVP$ ,  $P_{occl}/P_{ao}$ , and  $CFI_p$ ) vs. absolute collateral-derived myocardial perfusion ( $MBF_c$ ).

In our study population, the measurement difference ( $CPI - CFI_p$ ) decreased linearly with increasing LVEDP (Figure 6);  $CFI_p$  underestimated  $CPI$  for filling pressures up to 16 mmHg and overestimated  $CPI$  for higher filling pressures.

## Discussion

To date, coronary collateral flow has been assessed by several qualitative and quantitative methods and has been compared with clinical markers of collateralization and prognostic outcome in patients with CAD.<sup>1</sup> This study, for the first time, demonstrates that collateral-derived  $MBF$  can be measured using MCE during angioplasty and, in

comparison with simultaneous coronary pressure measurements, confirms the theoretical concept of pressure-derived collateral-flow assessment in humans. In this context and for future practical application, the question arises what would be the ideal parameter to characterize the coronary collateral circulation and whether it should be assessed in absolute terms or relative to the flow in the normally patent coronary artery.

## MCE and the assessment of the collateral circulation

MCE has been proposed for the assessment of collateral-derived myocardial perfusion by several authors.<sup>12-16</sup>

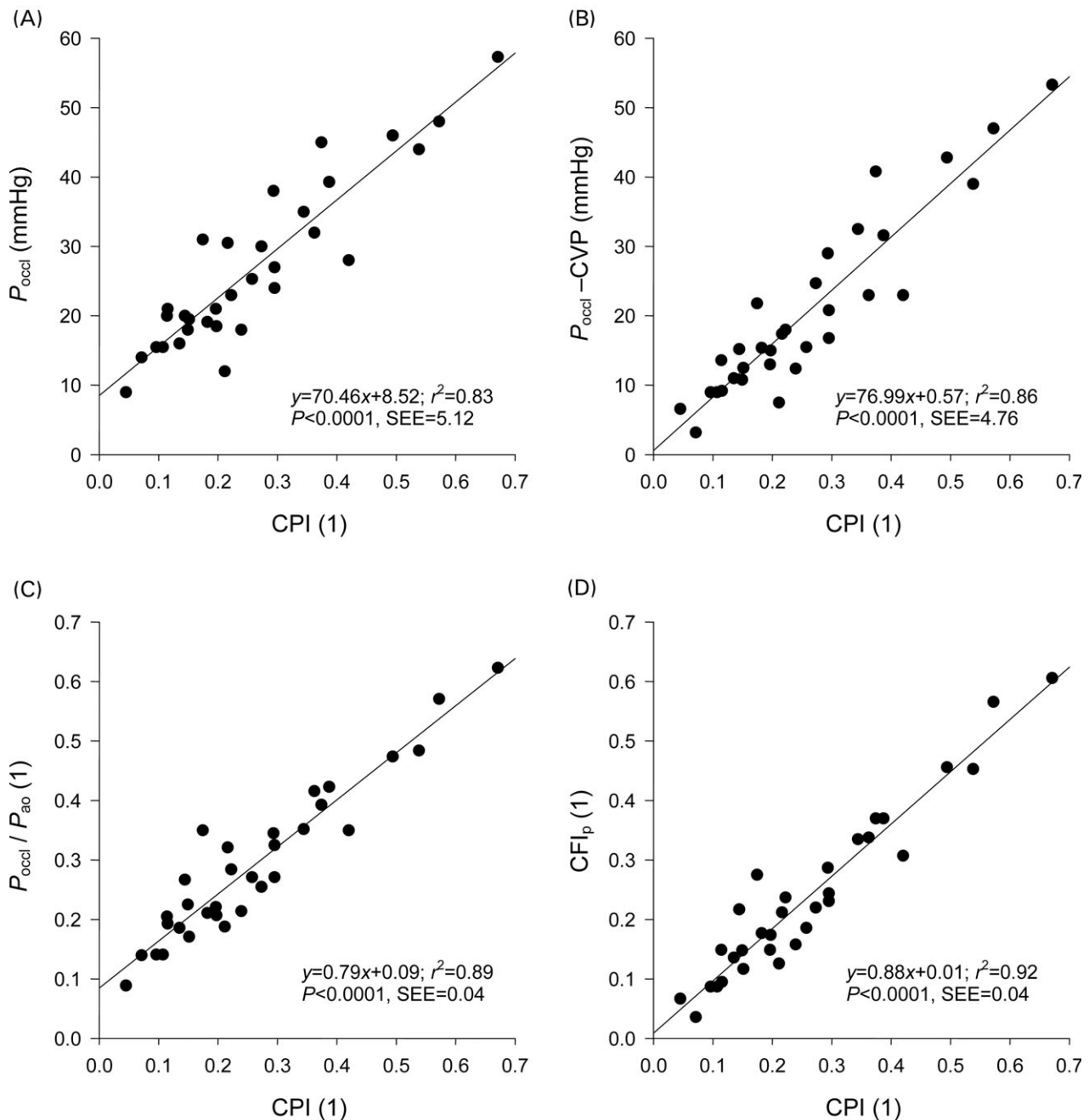
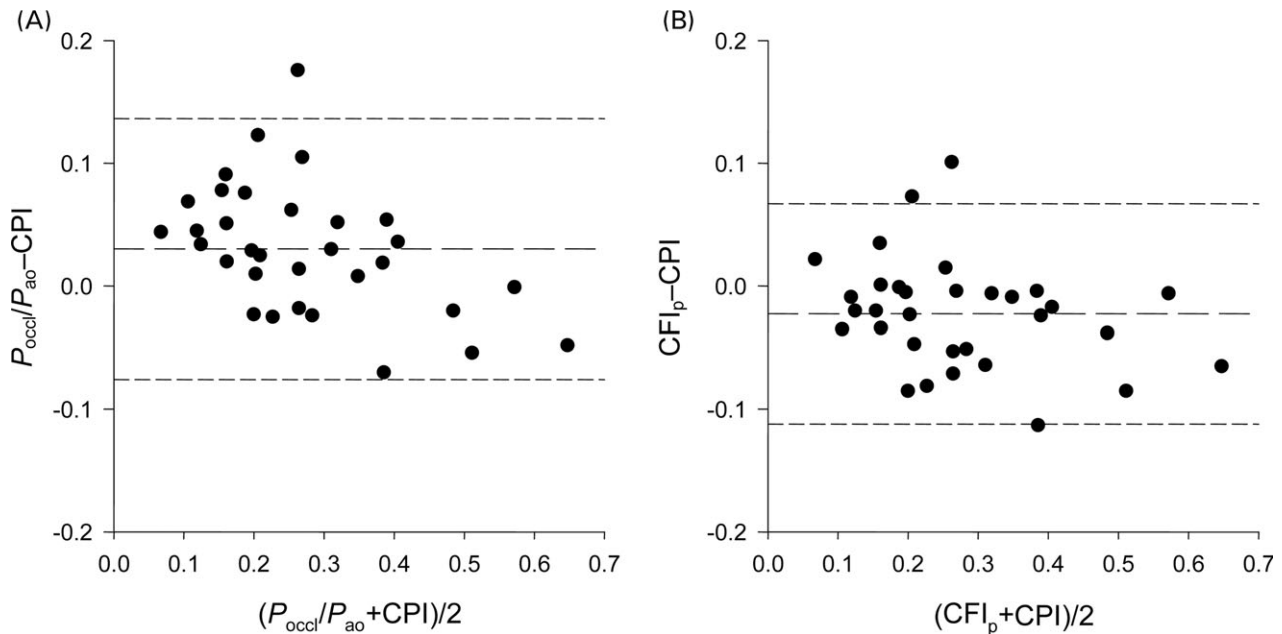

**Figure 4** Linear-regression analysis of pressure-derived collateral data ( $P_{\text{occl}}$ ,  $P_{\text{occl}} - \text{CVP}$ ,  $P_{\text{occl}}/P_{\text{ao}}$ , and  $\text{CFI}_p$ ) vs. relative collateral-derived myocardial perfusion (CPI).

Two human studies fulfilling the mandatory requirements, i.e. documented total coronary occlusion to avoid concomitant contrast flow via the native vessel, compared MCE and invasive collateral assessment. In patients with recent acute myocardial infarction,<sup>13</sup> angiographically visible collaterals correlated poorly with the size of the collateralized area as well as normalized UCA transit rates. In patients with stable CAD undergoing PCI,<sup>15</sup> pressure-derived CFI was modestly associated with peak signal intensity of UCA transit curves but not with UCA transit rates. The conflicting findings regarding UCA transit rates may be explained by the normalization performed by Sabia *et al.*<sup>13</sup> However, the reliability of UCA transit curve parameters is limited because of their dependency on

contrast agent concentration and mode of bolus application. Furthermore, the studies differed by the setting (acute myocardial infarction vs. stable CAD) and the reference method (visual<sup>13</sup> vs. pressure-derived<sup>15</sup> collateral assessment).

Refill curve parameter  $\beta$  has been shown to represent MBF in anaesthetized dogs.<sup>17</sup> However, the comparison with PET revealed only modest agreement between segmental MBF and  $\beta$ -data in conscious humans.<sup>11</sup> Likewise, the present study demonstrated weak correlation between  $P_{\text{occl}}$  and parameter  $\beta$  during angioplasty ( $r^2 = 0.16$ ,  $P = 0.02$ , data not shown) as well as between  $\text{CFI}_p$  and the ratio of parameter  $\beta$  during and after angioplasty ( $r^2 = 0.18$ ,  $P = 0.01$ , data not shown).



**Figure 5** Bland-Altman analysis of pressure and perfusion derived CFIs. (A) Measurement differences ( $P_{occl}/P_{ao} - CPI$ ) are plotted against mean values of  $P_{occl}/P_{ao}$  and CPI; long and short dashed lines indicate mean  $\pm 2SD$  of the measurement differences ( $P_{occl}/P_{ao} - CPI$ ). (B) Measurement differences ( $CFI_p - CPI$ ) are plotted against mean values of  $CFI_p$  and CPI; long and short dashed lines indicate mean  $\pm 2SD$  of measurement differences ( $CFI_p - CPI$ ).

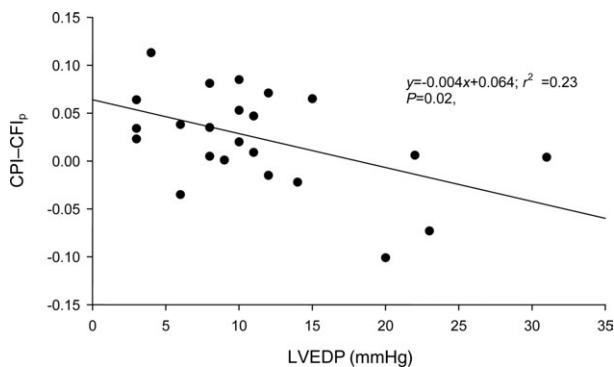

**Figure 6** Measurement difference between pressure- and perfusion-derived CFIs ( $CFI_p - CPI$ ) vs. LVEDP.

The methods discussed earlier share a common characteristic, which limits their applicability. The collateral-derived blood supply was described either by the collateral-dependent blood content (peak signal video intensity and size of the collateralized area) or by the exchange rate of this blood content (UCA transit rate, parameter  $\beta$ ). Our method overcomes this drawback as the collateral-dependent blood volume and its exchange frequency are combined to MBF given in  $\text{mL min}^{-1} \text{g}^{-1}$  [Eq. (7)]. With respect to the quantitative evaluation of the collateralization by MCE, we therefore suggest to assess collateral derived relative to normal myocardial perfusion on the basis of MBF measurements during and after angioplasty. MBF measurements by MCE have recently been introduced and validated against PET and intracoronary Doppler in healthy volunteers and patients with CAD.<sup>11</sup> Moreover, as single photon emission computed tomography<sup>10</sup> cannot provide MBF and PET is not applicable because of long acquisition times requiring coronary occlusion  $>5$  min, MBF measurements by MCE

have to be recognized as the gold standard to quantify the collateral-derived myocardial blood supply.

### Absolute parameters describing the collateral circulation

Presence or absence of angina pectoris and ECG ST-segment changes during balloon occlusion are related to the extent of collateralization.<sup>7,18</sup> However, the diagnostic value of angina pectoris is rather qualitative and the ECG's sensitivity to detect alterations in collateralization has not yet been defined.

At present, quantitative approaches to the human coronary collateralization rely on parameters such as X-ray contrast media clearance, radionuclide activity, and most notably, coronary pressure and flow velocity.<sup>1</sup>

It has been shown that absolute distal occlusive collateral-flow velocity as determined by intracoronary Doppler moderately correlated with coronary wedge pressure<sup>19</sup> and coronary wedge pressure relative to aortic pressure.<sup>20</sup> Quantitative assessment of <sup>99m</sup>Tc-sestamibi perfusion defects during angioplasty in patients with CAD further supported the association between coronary wedge pressure and collateral-derived myocardial blood supply.<sup>10</sup> The results of the present study finally establish the agreement between coronary wedge pressure and collateral-derived myocardial blood supply (Figure 3A).

In summary, these findings indicate that absolute coronary wedge pressure is a valuable indicator of collateral-derived blood supply, whereas absolute distal occlusive coronary flow velocity is less reliable. This result may be explained by inter-individual biological variability of local coronary artery cross-sectional areas<sup>21</sup> and flow velocities, which finally constitute coronary blood flow,<sup>22</sup> as well as by better reliability and superior robustness of pressure when compared with Doppler flow measurements.

## Relative parameters describing the collateral circulation

Human studies on myocardial perfusion reported considerable heterogeneity of normal MBF data.<sup>11,23</sup> Thus, indices describing collateral relative to normal myocardial blood supply are expected to be more suitable for determining the relevance of collateral vessels. Consistently, the accuracy of intracoronary Doppler measurements has been improved by normalizing coronary flow velocity taken at the same location after the removal of the stenosis and following cessation of reactive hyperaemia.<sup>7,19</sup>

By normalizing coronary wedge pressure with aortic pressure, Matsuo *et al.*<sup>10</sup> demonstrated improved agreement between pressure-derived collateral-flow data and radionuclide uptake defects during angioplasty. In our patients, relative and absolute pressure data correlated better with relative than with absolute collateral perfusion (Figures 3 and 4). In other words, the scatter between pressure- and perfusion-derived collateral data mainly emerges from inter-individual variations of normal perfusion, whereas aortic and CVP vary within smaller limits. Thus, normalization with MBF may partly explain the improved consistency of our data when compared with the results from Matsuo *et al.*<sup>10</sup> Besides, our method features two methodological advantages. First, the biophysical concept of pressure-derived collateral-flow measurements is based on considerations of myocardial perfusion. Secondly, perfusion imaging by MCE was completed during vessel occlusion and was not impaired by delayed scanning procedures due to the required transfer from cardiac catheterization laboratory to nuclear imaging facility.

Likely unexpected for some researchers in the field,<sup>20,24</sup> this cross-sectional study supports the consideration of CVP in order to increase the accuracy of pressure-derived collateral-flow data. Backpressure compensation is even more important in the case of follow-up studies, e.g. trials on therapeutic arteriogenesis, where it is desired to uncouple collateral-flow data from changing haemodynamic parameters. We therefore recommend in agreement with the theory<sup>6</sup> to include CVP as well as aortic pressure for the quantitative assessment of the collateralization by invasive pressure measurements.

For the pressure–flow relationships [Eqs. (2) and (3)] of the angioplasty model, we assumed that coronary blood vessels are rigid tubes, i.e. wall stress has no influence on the coronary circulation. However, coronary vessels are elastic and external pressures affect their haemodynamic properties. LVEDP is recognized as a useful substitute for wall stress, and it has been shown that collateral flow was overestimated by pressure when compared with Doppler flow measurements in the case of high LVEDP.<sup>25</sup> Correspondingly, we found that  $CFI_p$  overestimated CPI for LVEDP >16 mmHg. This phenomenon is called coronary waterfall: the volume flowrate in a waterfall depends on the conditions at the top of the fall and is independent of the height of the drop.<sup>26</sup>

## Non-invasive assessment of the collateral circulation

MCE has been proposed to become the optimal tool in the area of therapeutic angiogenesis.<sup>14</sup> Using the quantitative approach as presented in this study, MCE can now be

recognized as the reference method for the non-invasive quantification of coronary flow. However, we have to stress that invasive access is still required either to selectively delineate collateral pathways by brief artificial vessel occlusion or to confirm total coronary occlusion.<sup>1</sup> Future developments such as targeted microspheres<sup>27</sup> or highly selective UCA destruction will show whether a pure non-invasive approach to the collateral function will be feasible by MCE. For the present, MCE in conjunction with our quantification algorithm is ready for clinical studies on coronary collaterals in patients with documented total coronary occlusion.

## Limitations

We investigated 37 coronary arteries with their territories in 30 patients and independence of the data, a prerequisite for the statistical analysis, may be challenged. From the technical viewpoint, the use of coronary arteries as the basic unit for the statistical analyses is reasonable. Furthermore, the analysis considering only the first vessel/territory per patient (data not shown) revealed only marginal changes in haemodynamic statistics and did not change the significance of any result.

As a tomographic technique, the following deficiencies that may influence the results are inherent in MCE: although we took every precaution to locate the same myocardial territory during and after angioplasty, we cannot quantify the measurement error related to the investigation of unequal tomographic planes. Furthermore, MCE cannot assess collateral-related processes beyond the UCA detection volume of the transducer.

In some patients, collateral-derived MBF was below the range covered by the human validation study.<sup>11</sup> However, there are no theoretical restrictions regarding the analysis of slow refill curves.

Finally, we cannot comprehensively clarify the slight underestimation of CPI by  $CFI_p$ . It may be caused by changing haemodynamic conditions between the simultaneous assessment of  $MBF_c$  and  $CFI_p$  during angioplasty and the perfusion follow-up after angioplasty or by  $MBF_n$  reduction due to peri-procedural embolization into the microcirculation.

## Conclusion

During angioplasty, measurements of collateral-derived MBF by contrast echocardiography are feasible and proved the concept of coronary pressure-derived collateral-flow assessment in humans. MBF measurements by contrast echocardiography represent an important step towards the non-invasive quantification of collateral function and are ready to be used for clinical studies in models with documented total vessel occlusion.

## Acknowledgement

This work was supported by grants from the Swiss National Science Foundation (no. 3200B0-100065/1, C.S.) and the Swiss Heart Foundation.

**Conflict of interest:** the authors have no conflict of interest to disclose.



## References

- Seiler C. The human coronary collateral circulation. *Heart* 2003;**89**: 1352–1357.
- Schaper W, Ito WD. Molecular mechanisms of coronary collateral vessel growth. *Circ Res* 1996;**79**:911–919.
- Carmeliet P. Mechanisms of angiogenesis and arteriogenesis. *Nature Med* 2000;**6**:389–395.
- Seiler C, Pohl T, Wustmann K, Hutter D, Nicolet PA, Windecker S, Eberli FR, Meier B. Promotion of collateral growth by granulocyte-macrophage colony-stimulating factor in patients with coronary artery disease. A randomized, double-blind, placebo-controlled study. *Circulation* 2001;**104**:2012–2017.
- Meier B, Luethy P, Steffenino GD, Rutishauser W. Coronary wedge pressure in relation to spontaneously visible and recruitable collaterals. *Circulation* 1987;**75**:906–913.
- Pijls NH, van Son JA, Kirkeeide RL, de Bruyne B, Gould KL. Experimental basis of determining maximum coronary, myocardial, and collateral blood flow by pressure measurements for assessing functional stenosis severity before and after percutaneous transluminal coronary angioplasty. *Circulation* 1993;**87**:1354–1367.
- Seiler C, Fleisch M, Garachemani A, Meier B. Coronary collateral quantitation in patients with coronary artery disease using intravascular flow velocity or pressure measurements. *J Am Coll Cardiol* 1998;**32**: 1272–1279.
- Seiler C, Billinger M, Fleisch M, Meier B. Washout collaterometry: a new method of assessing collaterals using angiographic contrast clearance during coronary occlusion. *Heart* 2000;**86**:540–546.
- Werner GS, Ferrari M, Heinke S, Kueth F, Surber R, Richartz BM, Figulla HR. Angiographic assessment of collateral connections in comparison with invasively determined collateral function in chronic coronary occlusions. *Circulation* 2003;**107**:1972–1977.
- Matsuo H, Watanabe S, Kadosaki T, Yamaki T, Tanaka S, Miyata S, Segawa T, Matsuno Y, Tomita M, Fujiwara H. Validation of collateral fractional flow reserve by myocardial perfusion imaging. *Circulation* 2002;**105**:1060–1065.
- Vogel R, Indermühle A, Reinhardt J, Meier P, Siegrist PT, Namdar M, Kaufmann PA, Seiler C. The quantification of absolute myocardial perfusion in humans using contrast echocardiography: algorithm and validation. *J Am Coll Cardiol* 2005;**45**:754–762.
- Grill HP, Brinker JA, Taube JC, Walford GD, Midei MG, Flaherty JT, Weiss JL. Contrast echocardiographic mapping of collateralized myocardium in humans before and after angioplasty. *J Am Coll Cardiol* 1990;**16**: 1594–1600.
- Sabia PJ, Powers ER, Jayaweera AR, Ragosta M, Kaul S. Functional significance of collateral blood flow in patients with recent acute myocardial infarction. A study using myocardial contrast echocardiography. *Circulation* 1992;**85**:2080–2089.
- Mills JD, Fischer D, Villanueva FS. Coronary collateral development during chronic ischaemia: serial assessment using harmonic myocardial contrast echocardiography. *J Am Coll Cardiol* 2000;**36**:618–624.
- de Marchi SF, Schwerzmann M, Fleisch M, Billinger M, Meier B, Seiler C. Quantitative contrast echocardiographic assessment of collateral derived myocardial perfusion during elective coronary angioplasty. *Heart* 2001;**86**:324–329.
- Coggins MP, Sklenar J, Le DE, Wei K, Lindner JR, Kaul S. Noninvasive prediction of ultimate infarct size at the time of acute coronary occlusion based on the extent and the magnitude of collateral derived myocardial blood flow. *Circulation* 2001;**104**:2471–2477.
- Wei K, Jayaweera AR, Firoozan S, Linka A, Skyba DM, Kaul S. Quantification of myocardial blood flow with ultrasound-induced destruction of microbubbles administered as a continuous venous infusion. *Circulation* 1998;**97**:473–483.
- Pijls NH, Bech GJ, El Gamal MI, Bonnier HJ, de Bruyne B, van Gelder B, Michels HR, Koolen JJ. Quantification of recruitable coronary collateral blood flow in conscious humans and its potential to predict future ischemic events. *J Am Coll Cardiol* 1995;**25**:1522–1528.
- Mohri M, Egashira K, Kuga T, Shimokawa H, Takeshita A. Correlations between recruitable coronary collateral flow velocities, distal occlusion pressure, and electrocardiographic changes in patients undergoing angioplasty. *Jpn Circ J* 1997;**61**:971–978.
- van Liebergen RA, Piek JJ, Koch KT, de Winter RJ, Schotborgh CE, Lie KI. Quantification of collateral flow in humans: a comparison of angiographic, electrocardiographic and hemodynamic variables. *J Am Coll Cardiol* 1999;**33**:670–677.
- MacAlpin RN, Abbasi AS, Grollman JH, Eber L. Human coronary artery size during life. A cinearteriographic study. *Radiology* 1978;**108**:567–576.
- Anderson HV, Stokes MJ, Leon M, Abu-Halawa SA, Stuart Y, Kirkeeide RL. Coronary artery flow velocity is related to lumen area and regional left ventricular mass. *Circulation* 2000;**102**:48–54.
- Chareonthaitawee P, Kaufmann PA, Rimoldi O, Camici PG. Heterogeneity of resting and hyperemic myocardial blood flow in healthy humans. *Cardiovasc Res* 2001;**50**:151–161.
- Werner GS, Ferrari M, Heinke S, Kueth F, Surber R, Richartz BM, Figulla HR. Angiographic assessment of collateral connections in comparison with invasively determined collateral function in chronic coronary occlusions. *Circulation* 2003;**107**:1972–1977.
- de Marchi SF, Oswald Ph, Windecker S, Meier B, Seiler C. Reciprocal relationship between left ventricular filling pressure and the recruitable human coronary collateral circulation. *Eur Heart J* 2005;**26**:558–566.
- Fung YC. *Biomechanics: Circulation*. 2nd ed. New York: Springer; 1997. p507–509.
- Leong-Poi H, Christiansen J, Klibanov AL, Kaul S, Lindner JR. Noninvasive assessment of angiogenesis by ultrasound and microbubbles targeted to alpha(v)-integrins. *Circulation* 2003;**107**:455–460.