

SHIELDING DESIGN OF AN UNDERGROUND EXPERIMENTAL AREA AT POINT 5 OF THE CERN SUPER PROTON SYNCHROTRON (SPS)

Mario J. Mueller^{1,2,*} and Graham R. Stevenson²

¹Technische Universitaet Graz, Austria

²CERN—Safety Commission, Radiation Protection Group, Geneva, Switzerland

Increasing projected values of the circulating beam intensity in the Super Proton Synchrotron (SPS) and decreasing limits to radiation exposure, taken with the increasing non-acceptance of unjustified and unoptimised radiation exposures, have led to the need to re-assess the shielding between the ECX and ECA5 underground experimental areas of the SPS. Twenty years ago, these experimental areas at SPS-Point 5 housed the UA1 experiment, where Carlo Rubbia and his team verified the existence of W and Z bosons. The study reported here describes such a re-assessment based on simulations using the multipurpose FLUKA radiation transport code. This study concludes that while the main shield which is made of concrete blocks and is 4.8 m thick satisfactorily meets the current design limits even at the highest intensities presently planned for the SPS, dose rates calculated for liaison areas on both sides of the main shield significantly exceed the design limits. Possible ways of improving the shielding situation are discussed.

INTRODUCTION

Re-assessment goals

The ECX5 experimental area and ECA5 assembly area were constructed in the late 1970s to house the UA1 experiment designed to study p-pbar collisions. At that time, there was a considerable body of knowledge concerning shield design available from the studies at proton accelerators with energies up to 30 GeV. Particle transport cascade codes were not, at that time, capable of dealing with deep lateral shielding calculations, but they were able to determine the development of the high-energy (several hundred GeV) cascades in their early stages and thus could give the extended source term that could be used with the lower energy experimental studies to form the basis of the ECX/ECA5 design. This proved sufficient for many years of Super Proton Synchrotron (SPS) operation.

The shielding around the ECA5 area was designed for an SPS intensity of $\sim 3 \times 10^{12}$ protons s^{-1} ; future plans for the SPS involve intensities of $\sim 1.2 \times 10^{13}$ protons s^{-1} . In the late 1970s, the annual limit for the exposure of radiation workers was 50 mSv. At present the annual limit is 20 mSv. This has led to more strict constraints on exposure at all levels and this has also to be seen in the light of increasing non-acceptance of unjustified and unoptimised radiation exposure. Furthermore, particle transport cascade codes, such as FLUKA, MCNPX and MARS, are now capable of following cascades to large depths in shielding. It was, therefore, considered as an eminent opportunity to re-assess the shielding around ECX5

using the best available modern techniques. One major goal of the study is to find shielding improvements that could decrease dose rates at ground level by up to a factor of 3.

Geometry of the SPS5 area

The SPS is one of the several particle accelerator systems at CERN, the second largest in circumference, housed up to 60 m below ground level. It is shown schematically in Figure 1a. The SPS-straight-section at point 5 is indicated as 'Sextant 5'. A three-dimensional (3-D) representation of the underground areas is given in Figure 1b; both ECA5 and ECX5 are vertical cylinders, the former opens at the ground level while the latter covered by a dome. A complex liaison zone links these cylinders.

Two sections of Figure 1b are indicated in Figure 2. Figure 2a shows a vertical section with the concrete shield, while Figure 2b shows a horizontal section at the height of the SPS beam.

Beam intensities, doses and dose rates

The maximum intensity is 1.2×10^{13} protons s^{-1} at 450 GeV c^{-1} . This intensity is considered to be identical to that used in Ref. (1), based on Refs (2) and (3), for the injection lines of CERN Neutrinos to Grand Sasso (CNGS) and the Large Hadron Collider LHC⁽⁴⁾.

Table 1 gives the current radiological constraints based on the policy stated in Ref. (5) and in the CERN Radiation Safety Manual⁽⁶⁾. The over-riding constraint is that the dose rate for a full beam loss should not be > 100 mSv h^{-1} . Since ECA5 is presently classified as a Simple Controlled Radiation

*Corresponding author: mario.mueller@cern.ch

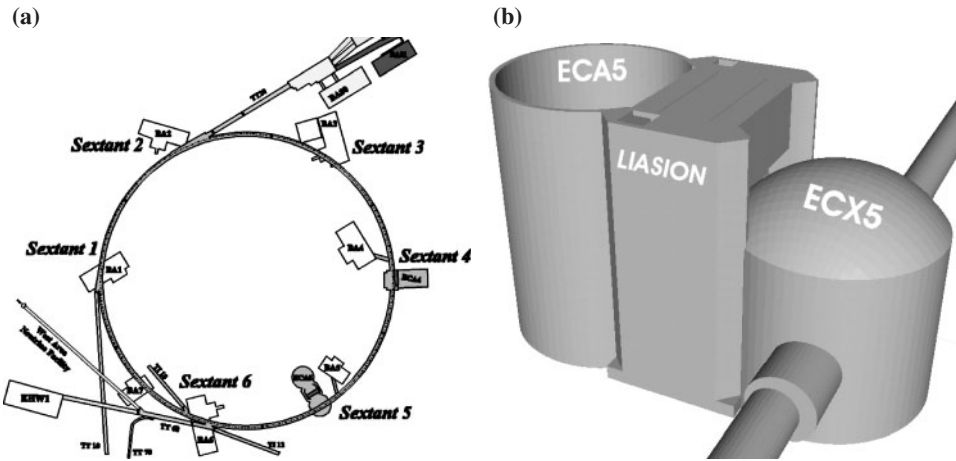

Figure 1. (a) Schematic diagram of SPS installations and (b) SPS5 installations below surface.

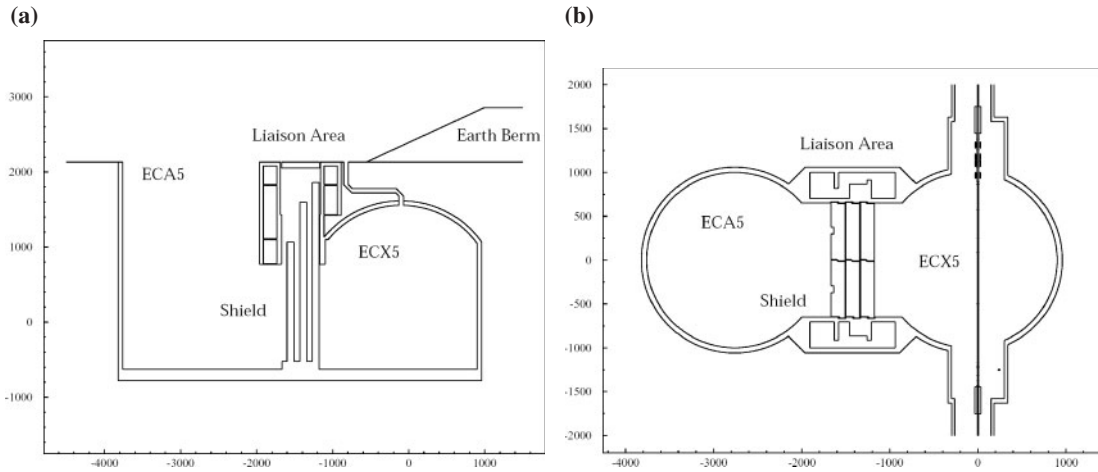

Figure 2. (a) Vertical section of the ECA/ECX5 area and (b) horizontal section at beam height of the ECA/ECX5 area. All the dimensions are in cm.

Table 1. Design constraints for doses and dose rates outside shielding.

Area classification	Maximum loss		Normal loss Dose rate ($\mu\text{Sv h}^{-1}$)	Maximum dose rate (transient conditions) ($\mu\text{Sv h}^{-1}$)
	Dose (mSv)	Dose rate (mSv h^{-1})		
Simple controlled	50	—	10	100
Supervised	2.5	—	1	7.5
Non-designated	0.3	—	0.1	0.5
Any area		100	—	—

Area, this means a dose-rate constraint of $10 \mu\text{Sv h}^{-1}$, which implies that beam losses under normal conditions should not exceed 10^{-4} of the maximum beam intensity.

To maintain the areas above ground level as Supervised Radiation Areas, the dose-rate constraint will be $1 \mu\text{Sv h}^{-1}$. As a design limit for such areas, a safety factor of ~ 3 is assumed, providing limits of

3 and $0.3 \mu\text{Sv h}^{-1}$ for the assumed beam losses during normal SPS operation.

DETAILS OF THE SIMULATION

The Monte Carlo code—FLUKA

The calculations were carried out using FLUKA-2002^(7,8). For the SPS5 calculations, only hadron components of the particle cascade were simulated since they contribute to over 80% of the dose⁽⁹⁾.

Co-ordinate system

A right-handed orthogonal system (Figure 1b) was used:

- vertical x -axis starting at beam height;
- horizontal y -axis, pointing away from the ECA area with its origin at the beamline;
- horizontal z -axis, aligned with the proton beam, in the median plane of the ECX/ECA, but pointing in the upstream direction.

Geometry

The geometry of the ECA/ECX5 areas, as used for the simulations, consists of four main parts:

- (1) *The SPS tunnel*: The tunnel is considered to be a cylinder of 2.07 m radius with the floor at a distance of 1.08 m below the axis of the tunnel. The SPS beam is 1.2 m above the floor of the tunnel and 58 cm from the tunnel axis towards the outside of the SPS ring. Enlargements to the tunnel exist on either side of the ECX5 experimental area, cylindrical with a 3 m radius and a floor 1.6 m below the beam; the axis is centred on the beam in the vertical x -direction and horizontal y -direction. The walls and floor were assumed to be 30 cm thick. The quadrupole QF51810 is followed by four Wiggler magnets (MDHW51832, MDHW51834, MDHW51835 and MDHW51837) and ends up at quadrupole QF51910.
- (2) *The ECX experimental area*: It consists of a vertical cylinder ($r_{\min} = 10$ m) with the vertical axis shifted 1 m from the beam axis in the negative y -direction. The floor is 5.3 m below beam height. The roof, a spherical dome ($r = 12.4$ m centred at 8.48 m above the floor) is covered by 5 m earth. All wall thicknesses were considered to be 50 cm of concrete.
- (3) *The ECA assembly area*: It consists of a vertical cylinder ($r_{\min} = 10$ m), with its axis situated at a distance of 26.6 m from the ECX axis—opened at the ground level, floor at 5.3 m below beam height and 26.6 m below the ground level. The

thickness of the walls was again considered to be 50 cm.

- (4) *The liaison area*: It is located between the ECA and ECX areas. At the sides there are two pillars, separated by a distance of 13 m, each contains three vertical shafts of approximately square cross section, leading from ground to floor level. On the ECA side, there are two personnel access shafts—an elevator in the upstream pillar and a spiral staircase in the downstream pillar. At 12.6 m above the floor, the two pillars are linked by two series of cross-galleries, separated by a gap of 5 m in the y -direction. This open gap between the pillars is filled with shield blocks during SPS operation. Additional 1.6×1.6 m² pillars of concrete blocks in the central shafts, from the floor to just above beam height, are installed to provide extra shielding; for shielding improvements these pillars can be extended up to the fifth level.

The ECX/ECA volumes have been divided into nine levels as an aid to understanding the geometry of the different levels, especially in the liaison areas.

Source particles

Separate simulations were performed with the 450 GeV c^{-1} protons starting at 11 different positions (loss or entry points (EP) at the front end of the two quadrupoles (EP1 and EP11), the four Wiggler magnets (EP3–6) and for five vacuum flanges (EP2, EP7–10), along the beamline). More detailed results are available in a separate report⁽¹⁰⁾.

Dose equivalent

The track-lengths of neutrons, protons and pions were scored in cartesian bin-structures, in order to get the average fluence. The use of the FLUKA fluence-to-dose option^(11,12) allows one to convert fluence directly into effective dose. These conversion factors are based on fits to the data of Pelliccioni *et al.*⁽¹³⁾ and the special concept as described in Ref. (14). The whole SPS5 geometry is covered by six bin structures with a bin size of 20 and 25 cm.

RESULTS OF THE SIMULATIONS

General

In order to assist in the interpretation of the large quantities of data, certain critical volumes (CVs) were defined for each level, corresponding to positions close to the shield where persons could have access during beam operation. The position of these $2 \times 2 \times 2$ m³ volumes are indicated schematically in Figure 3.

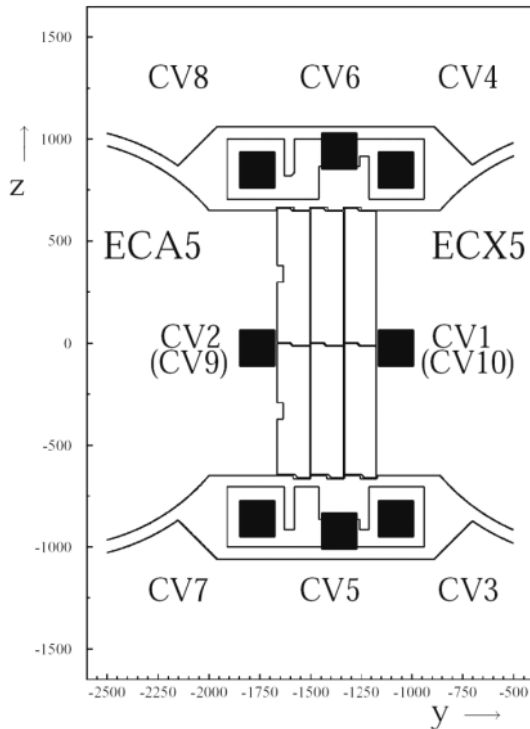

Figure 3. Horizontal section through the main shield indicating the positions of the CV.

Main shield

Hadron dose rates on both sides of the shielding are shown in Figure 4. Figure 4a indicates that the dose rate on the ECX side of the shield is essentially independent of the EP and level and approaches 1000 Sv h^{-1} . Figure 4b, for the ECA side of the shield, suffers from poor statistics, but one can conclude that the dose rate for Level 9 (which is accessible) is safely below the critical level of 100 mSv h^{-1} .

Vertical shafts

The vertical shafts on the ECA side in the liaison areas are accessible at all times during beam operation. Figure 5 shows the hadron dose rates at different levels. The highest dose rate for the lift shaft (Figure 5a) occurs at Levels 5 and 6 for EP3–7. This maximum value is approximately a factor of 3 higher than the critical value of 100 mSv h^{-1} . In the spiral staircase shaft (Figure 5b), dose rates exceed the critical value by about a factor of 3–5 for almost all proton EPs in the lower Levels 6–9.

Surface levels

Hadron dose rates at the upper two levels for different proton EPs are shown in Figure 6. The data for the surface level (Level 0) in Figure 6a indicate that, apart from the top of the staircase, dose rates are significantly $< 100 \text{ mSv h}^{-1}$ value. This is not the

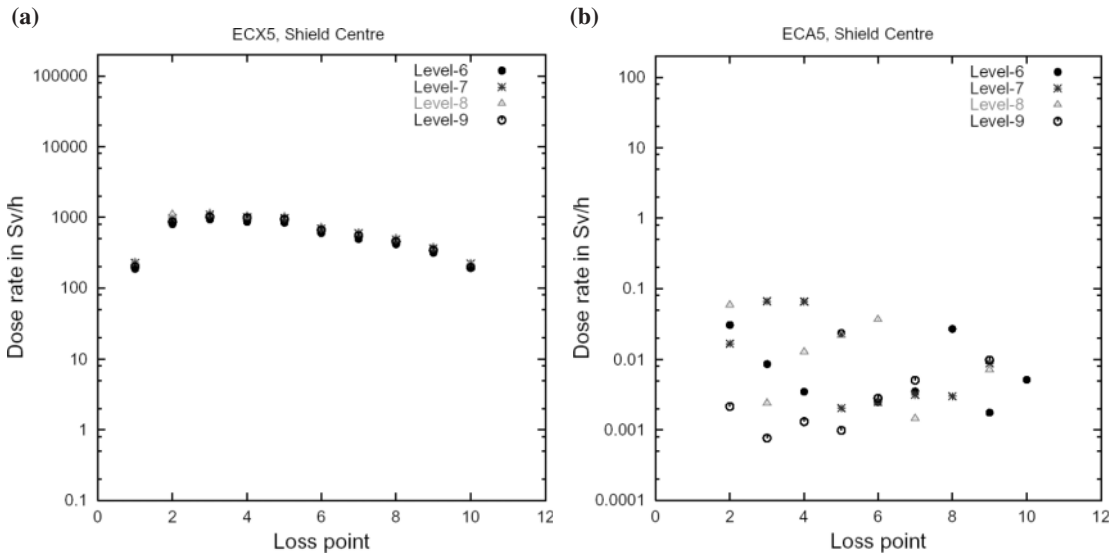

Figure 4. Hadron dose rates as a function of EP of the proton loss for different levels. (a) Data for CV 1 on the ECX side of the main shield and (b) data for CV 2 on the ECA side of the main shield.

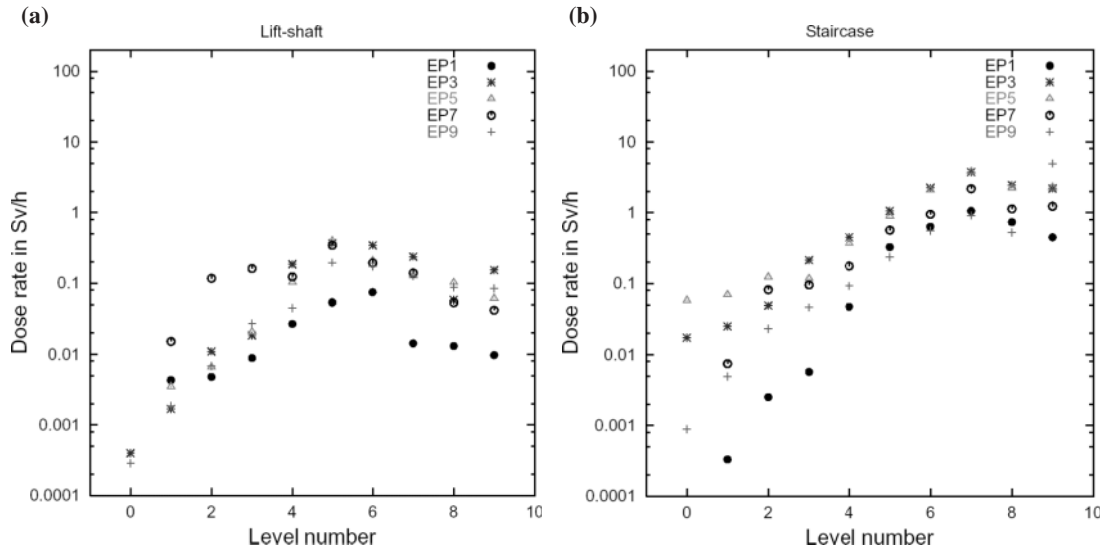

Figure 5. Hadron dose rates as a function of level number for the accessible shafts in the liaison areas. (a) Lift-shaft, CV 8, in the upstream liaison area on the ECA side of the main shield and (b) spiral staircase shaft, CV 7, in the downstream liaison area on the ECA side of the main shield.

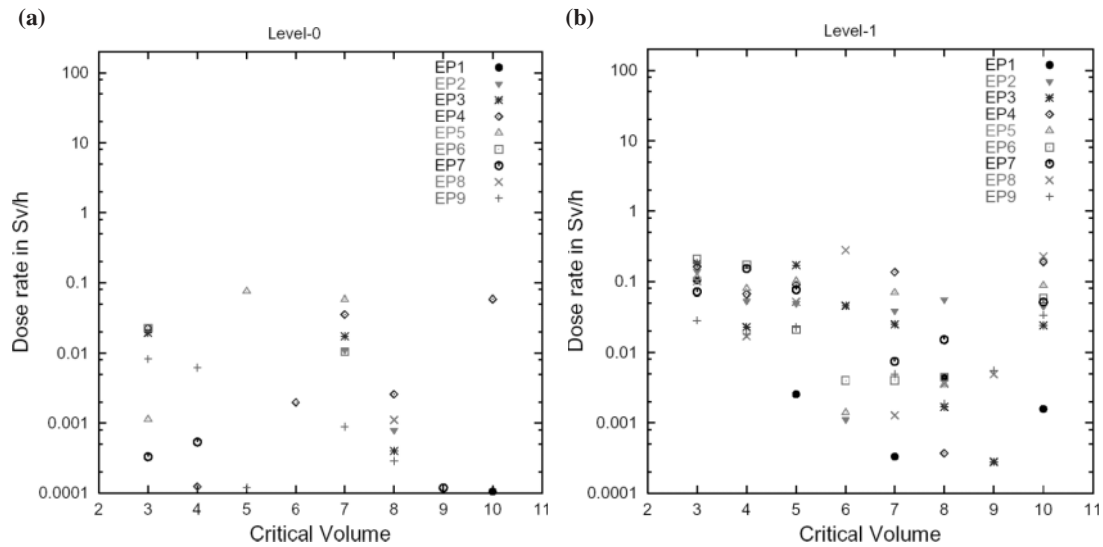

Figure 6. Hadron dose rates at the CV in the upper two levels for different proton EP. (a) Data for the surface level (Level 0) and (b) data for the first underground level (Level 1).

case for Level 1 (Figure 6b), which is the first underground level, where dose rates are $>100 \text{ mSv h}^{-1}$ in many critical volumes and for many loss conditions.

CONCLUSIONS

(1) The main shield, which is made up of concrete blocks and is 4.8 m thick, satisfactorily meets the

current design limits even at the highest intensities presently planned for the SPS.

- (2) Dose rates calculated for the lift-shaft and the shaft for the spiral staircase on the ECA side exceed the design limits by more than a factor of 3 and in certain cases by a factor of 3.
- (3) Dose rates in the first underground galleries (Level 1) can, under certain circumstances, exceed the design limits.

Shielding improvements such as columns of concrete blocks in the central shafts of the liaison areas, installing columns of concrete blocks on the ECX side along the main shield and in front of the openings to the liaison areas on the ECX side offer the possibility of lowering the resulting dose rate for Levels 0 and 1. These studies are on-going.

REFERENCES

1. Stevenson, G. R. *Shielding studies for the access shafts to the LHC injection lines*. CERN Internal Report CERN/TIS-RP/IR/99-23 (Geneva: CERN) (1999).
2. Höfert, M., Potter, K. and Stevenson, G. R. *Summary of design values, dose limits, interaction rates etc. for use in estimating radiological quantities associated with LHC-operation*. CERN Internal Report TIS-RP/IR/95-19.1 (Geneva: CERN) (1995).
3. Weisse, E. In: Minutes of the 50th PLC meeting, 21 April (1999).
4. Ferrari, A., Huhtinen, M., Rollet, S. and Stevenson, G. R. *Procedures used during the verification of shielding and access-ways at CERN's Large Hadron Collider (LHC) using the FLUKA code*. In: Proceedings of the American Nuclear Society's 1997 Winter Meeting on Nuclear Applications of Accelerator Technology, Albuquerque, NM, 16–20 November 1997, p. 463, CERN Preprint CERN/TIS-RP/97-14/CF (1997).
5. Höfert, M. and Stevenson, G. R. *Design limits for doses and dose rates for beam operation at the LHC*. CERN Internal Report TIS-RP/IR/95-04 (Geneva: CERN) (1995).
6. Radiation Protection Group. *Radiation Safety Manual 1996*. (Geneva: CERN) (1996).
7. Fasso, A., Ferrari, A. and Sala, P. R. *Electron–photon transport in FLUKA: status*. In: Proceedings of the Monte Carlo 2000 Conference: Invited talk, Lisbon, 23–26 October 2000. Kling, A., Barao, F., Nakagawa, M., Tavora, L. and Vaz, P., Eds. (Berlin: Springer-Verlag) pp. 159–164 (2001).
8. Fasso, A., Ferrari, A., Ranft, J. and Sala, P. R. *FLUKA: status and prospective for hadronic applications*. In: Proceedings of the Monte Carlo 2000 Conference: Invited talk, Lisbon, 23–26 October 2000. Kling, A., Barao, F., Nakagawa, M., Tavora, L. and Vaz, P., Eds. (Berlin: Springer-Verlag) pp. 955–960 (2001).
9. Stevenson, G. R. and Huhtinen, M. *A lateral shielding study for the LHC main ring*. CERN Internal Report CERN/TIS-RP/IR/94-33 (Geneva: CERN) (1994).
10. Mueller, M. J. and Stevenson, G. R. *Radiation levels in ECA5 due to proton losses in ECX5*. CERN Technical Note CERN-TIS-2003-020-RP-TN (Geneva: CERN) (2003).
11. Ferrari, A., Pelliccioni, M. and Pillon, M. *Fluence to effective dose and effective dose equivalent conversion coefficients for photons from 50 keV to 10 GeV*. Radiat. Prot. Dosim. **67**, 245–251 (1996).
12. Roesler, S. and Stevenson, G. R. *DEQ: a routine for dose equivalent and effective dose conversion in Monte-Carlo programs*. CERN Internal Report TIS-RP/TN/2002 (Geneva: CERN) (in preparation) (2002).
13. Pelliccioni, M. *Overview of fluence to effective dose and fluence to ambient dose equivalent conversion coefficients for high-energy radiation calculated using the FLUKA code*. Radiat. Prot. Dosim. **88**, 279–297 (2000).
14. Stevenson, G. R. *The implications of ICRP publication 74 for the design of the LHC shielding*. CERN Divisional Report CERN/TIS-RP/97-15 (Geneva: CERN) (1997).