

# Does Modern Helicopter Construction Reduce Noise Exposure in Helicopter Rescue Operations?

THOMAS KÜPPER<sup>1,2,\*</sup>, PAUL JANSING<sup>3,4</sup>, VOLKER SCHÖFFL<sup>5,6</sup>, and SIMONE VAN DER GIET<sup>1</sup>

<sup>1</sup> *Institute for Occupational and Social Medicine, RWTH Aachen University, Aachen/Germany;*

<sup>2</sup> *Medical Commission of the Union Internationale des Associations d'Alpinisme (UIAA MedCom*

*Bern, Switzerland);* <sup>3</sup> *State Institute for Occupational Health and Safety of North-Rhine Westphalia,*

*Düsseldorf/Germany;* <sup>4</sup> *Institute of Occupational Medicine, Heinrich Heine-University Düsseldorf,*

*Germany;* <sup>5</sup> *Department of Trauma and Orthopedic Surgery, Klinikum Bamberg, Germany;*

<sup>6</sup> *Department of Trauma Surgery, Friedrich Alexander University Erlangen-Nuremberg, Germany*

Received 8 June 2012; in final form 25 May 2012; published online 24 September 2012

**Background:** During helicopter rescue operations the medical personnel are at high risk for hearing damage by noise exposure. There are two important factors to be taken into account: first, the extreme variability, with some days involving no exposure but other days with extreme exposure; second, the extreme noise levels during work outside the helicopter, e.g. during winch operations. The benefit of modern, less noisier constructions and the consequences for noise protection are still unknown.

**Objectives:** We estimated the noise exposure of the personnel for different helicopter types used during rescue operations in the Alps and in other regions of the world with special regard to the advanced types like Eurocopter EC 135 to compare the benefit of modern constructions for noise protection with earlier ones.

**Methods:** The rescue operations over 1 year of four rescue bases in the Alps (Raron and Zermatt in Switzerland; Landeck and Innsbruck in Austria, n = 2731) were analyzed for duration of rescue operations (noise exposure). Noise levels were measured during rescue operations at defined points inside and outside the different aircraft. The setting is according to the European standard (Richtlinie 2003/10/EG Amtsblatt) and to Class 1 DIN/IEC 651. With both data sets the equivalent noise level  $L_{eq8h}$  was calculated. For comparison it was assumed that all rescue operations were performed with a specific type of helicopter. Then model calculations for noise exposure by different helicopter types, such as Alouette IIIb, Alouette II 'Lama', Ecureuil AS350, Bell UH1D, Eurocopter EC135, and others were performed.

**Results and conclusions:** Depending on modern technologies the situation for the personnel has been improved significantly. Nevertheless noise prevention, which includes noise intermissions in spare time, is essential. Medical checks of the crews by occupational medicine (e.g. 'G20' in Germany) are still mandatory.

**Keywords:** alpine rescue; aviation; helicopter; mountain rescue; noise; occupational medicine; occupational noise

## INTRODUCTION

Although the helicopter's noise approximates 1/10000 of the total aircraft's power, it is a noise

source of tremendous energy (Kloppel *et al.*, 1993). Compared with industrial workers the exposure of crews of helicopter rescue organizations differs in at least two important factors: (i) extreme variability with some days with no exposure (e.g. no operations due to bad weather) but other days with extreme exposure (several or long operations) and (ii) very

\*Author to whom correspondence should be addressed.  
Tel: +49-241-8088880; fax: +49-241-8082587;  
email: [tkuepper@ukaachen.de](mailto:tkuepper@ukaachen.de)

high to extreme noise levels with limited protection during work outside the aircraft (Küpper *et al.*, 2004). The latter is caused by operational tactics like so-called hot-loading, where material or the patient is loaded into the hovering helicopter or, more often, at the beginning of rescue and medical aid before the engine is shut down completely. During winch operations the crew is also exposed to high noise levels for a significant period, especially when returning from the place of accident: if smaller helicopters are used, rescuer and patient cannot enter the helicopter again after they are winched up and so they have to fly outside until the nearest place for a safe intermediate landing is reached. In an earlier study we focused on formerly most often used helicopters Alouette II and Alouette III and reported that nearly every day with at least one rescue operation—even a short one near the base—causes equivalent noise levels ( $Leq_{8h}$ ) of  $>85$  dB(A) which is known to cause risk of hearing loss (Küpper *et al.*, 2004).

Several sets of measurements of helicopter noise were done in the past, but we are extending these now to modern types of helicopters to see what difference this makes and to calculate the dose from various machines to enable a direct comparison of the different types. In this study we focused on modern helicopters with advanced technology which is said to reduce noise exposure. For comparison we also included older types to clarify the history of helicopter noise exposure of rescue crews. The are of special interest for expert purposes when employees apply for the acceptance of their hearing loss as occupational disease.

## MATERIAL AND METHODS

Noise levels were measured at typical places inside and outside the several types of aircrafts as indicated for Eurocopter EC 135 in Fig. 1. These positions represent the positions of crew members during rescue operations. At every position at least three independent measures on different flights were taken for at least 1 min each. Data were stored as noise level (dB). For calculation of the equivalent noise level (see below) the average of these noise levels was used if their difference was  $<5\%$ .

The microphone was a capacitor microphone (Type 4135; Brüel and Kjaer). This type shows an extraordinary linearity in the range of 20–2000 Hz and the signal is fairly linear between 2 kHz and 20 kHz. From previous investigations about aviation and military noise (shooting) we knew that this one gives the most reliable data of the microphones which were available. This may be a consequence

of the construction which guarantees that it can be used in strong magnetic fields (e.g. near a big engine). The signal was digitally stored according to DIN IEC 651 by the integrating-averaging sound level meter Norsonic 110 Sound and Vibration Analyzer (Norsonic AS, Tranby/Norway). The system was switched to 'fast' mode and assessment was switched to dB(A) (DIN, 1994). The system was calibrated according to DIN IEC 651 using a sound calibrator type 4230 (Brüel and Kjaer series no. 1511608) at 94 dB and 1000 Hz. The design of measurement corresponds to class 1 DIN IEC 651 (DIN, 1994).

For the measurements outside the helicopter the microphone was covered against the downwash of the rotor with a windscreen (Brüel and Kjaer) to exclude errors in measurements. Data acquisition inside the aircraft was performed during constant straight flight. According to DIN ISO 5129, a specification which was specifically designed for noise measurements inside aircrafts, at each point of measurement the microphone was held directly (0.1 m) beside of the ear of a person working or sitting at the positions as marked in Fig. 1 (DIN, 2003).

The equivalent noise level ( $Leq_{8h}$ ) was calculated using the equation given by DIN 45645-2 for an 8-h period (DIN, 1997). With abandonment of the factors for tonality and pulse, which were specific German recommendations (which were abolished

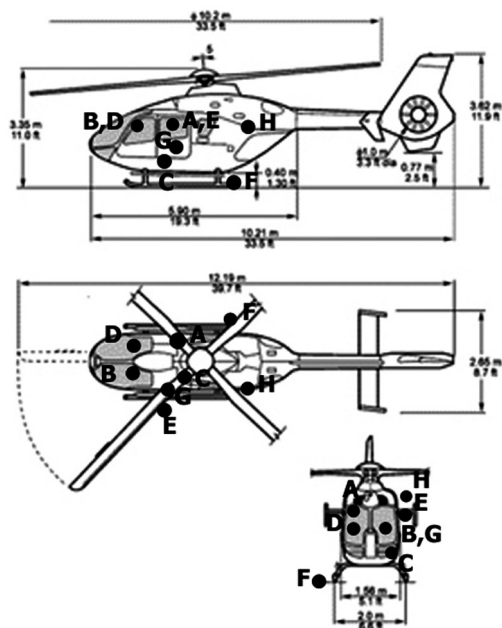

Fig. 1. Position of the microphone at the Eurocopter EC 135.

later), data evaluation is compatible with those of other countries and the European standard (EU, 2003). The formula should be used for noise levels which are almost constant during a work shift. If there are phases with significantly more or less noise levels during the shift, as for aviation personnel with no exposure when planning the flight and a more or less high exposure during flight, the shift should be classified into sections of similar noise levels.

Following this recommendation we calculated the respective noise levels for the following periods: flight duration (to the site of the accident, to the hospital and back to base) and duration of winch operations. These data were obtained from the pilot's flight reports. The time to treat the patient at the site of the accident and the periods at the airbase between the rescue operations were defined as 60 dB(A), which corresponds to the noise level of a normal conversation. The equivalent noise level for any day and any crew for the period of investigation was calculated for any flight (period of operation), per day and per base as described above.

To calculate the exposure of the personnel the rescue operations of four bases were analyzed for more than 1 year [total, 2776: Switzerland, Zermatt ( $n = 622$ ) and Raron ( $n = 457$ ); Austria, Landeck ( $n = 836$ ) and Innsbruck ( $n = 811$ )]. These data were the same as used for an earlier investigation (Küpper *et al.*, 2004) to enable a direct comparison of the actual results with earlier ones. The design and data evaluation of this study are according to the new regulations of the European Community (EU, 2003).

In the actual study the following helicopters commonly used for rescue operations were included: Eurocopter EC 135 P2, BK 117 (Messerschmitt-Bölkow-Blohm/Eurocopter), and Bell UH-1D. Identical calculations but with data obtained from literature were performed for the following aircrafts for better understanding of the history of noise exposure during rescue operations: Mi-4, Bell 412, Sikorsky H-23 D (=UH12), Sikorsky H-34, and Sikorsky H-37. Although these types are mainly of historical interest, some are still in use, mostly in developing countries or for training purposes (e.g. Sikorsky H23 D). For occupational medicine these historical data are of interest in surveying patients with occupational noise disease.

For statistics the Wilcoxon Signed-ranks Test was used to check whether there were differences in the sound levels between the several points of measurement and  $P < 0.05$  was defined as significant. At least 10 independent recordings were taken at each location. The error of measurement was calculated as the standard deviation in percentage of mean value as recommended in DIN (1994).

## RESULTS

With variations of less than 4% the results are reproducible, although the situation and environment of data acquisition were very unusual. An example for the distribution of daily noise exposure is given in Fig. 2, based on Küpper *et al.*, (2004) with 42.3% of days without noise exposure at Raron (Switzerland), and 36.3% at Zermatt (Switzerland), 31.1% at Landeck (Austria), and 15.8% at Innsbruck (Austria), respectively.

In EC 135 the noise levels outside the aircraft were 100.1 to 107.8 dB(A), with the highest exposure during refuelling of the helicopter. Because of the

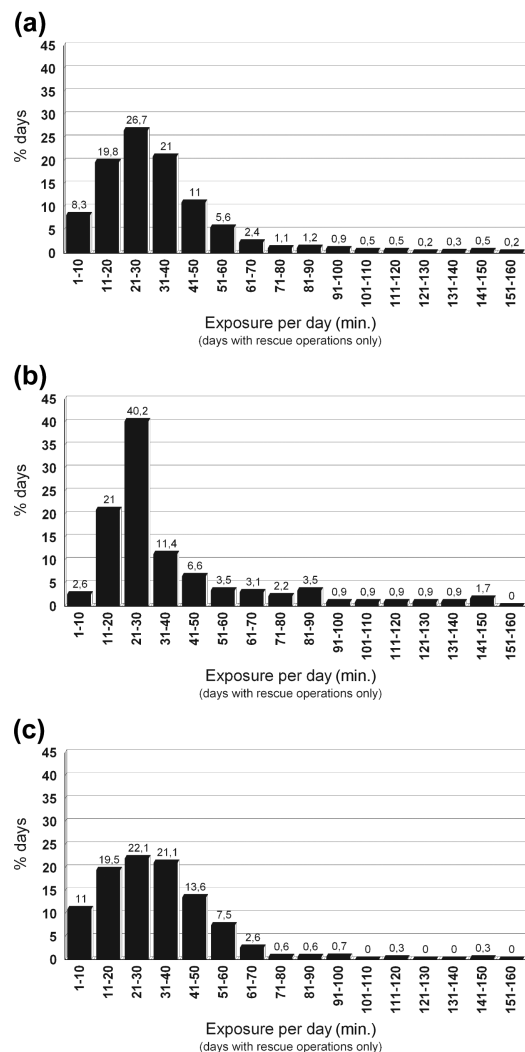

Fig. 2. Distribution of daily noise exposure (all bases). (a) Raron (Switzerland); (b) Innsbruck (Austria); (c) data from Küpper *et al.*, (2004).

overlap of the ranges of the several results obtained at the different points (no significant differences) we assumed that the noise exposure at these points outside the helicopter is comparable. With the highest levels dominating the total exposure of an 8-h day and the personnel regularly exposed to these levels (e.g. while hyphenated elsewhere or winch operations) 104 dB(A) was used to calculate the exposure outside the aircraft. Inside the results ranged from 86.1 to 94.8 dB(A) (Not defined elsewhere door open during winch operations: 98.4) and 94 dB(A) was used to calculate the exposure inside the aircraft.

BK 117 showed noise levels from 92.3 to 94.9 dB(A) inside and from 106.2 to 108.8 dB(A) outside the aircraft. Again, the position ‘refuelling’ was the noisiest of all points measured. The different points did not differ significantly. Therefore 108 dB(A) was defined as ‘outside level’ and 95 dB(A) as ‘inside level’ for further calculations.

At the Bell UH-1D we measured 94.0 to 96.1 dB(A) inside and 102.9 to 106,0 db(A) outside the aircraft. For calculations 95 dB(A) (‘inside’) and 105 dB(A) (‘outside’) were used as no significant differences were found between the points of measurement. The corresponding results for Ecureuil were 98.2 to 101.7 db(A) and 108.3 to 112.0 dB(A). Here 101 db(A) was used to calculate the exposure inside the aircraft, and 111 dB(A) for outside, respectively.

Inside the Alouette II ‘Lama’ noise levels were between 106 and 109 dB(A) and outside between 116 and 120 dB(A). To calculate Leq8h 108 dB(A) and 120 dB(A) were used, respectively. Alouette III B levels were between 104.6 and 106.5 dB(A) inside and between 116 and 120 dB(A) outside the aircraft. Again, the highest levels were measured during refuelling and winch operations. For this helicopter

type Leq8h was based on 106 dB(A) and 120 dB(A), respectively.

For the helicopter types which are in Europe more of historical interest (or for expertise to judge occupational noise disease) data from literature were taken to calculate  $L_{eq8h}$ .

The mean  $L_{eq8h}$  of the personnel using an EC 135 was 85.8 dB(A) (Wallis: 85.4; Tyrol: 86.1;  $P < 0.001$ ) with a spectrum between 70–74 dB(A) (1.6% of operation days (OD)) and 95–99 dB(A) (0.4% of OD, Fig. 3, Fig. 4, Table 1). For all helicopter types the airbases located in Tyrol showed a significantly higher  $L_{eq8h}$  due to the longer approaches to the sites of the accidents along the long north-south-valleys there (Fig. 3; Table 1). The mean  $L_{eq8h}$  for Bk 117 was 87.2 dB(A) (Wallis: 86.8; Tyrol: 87.6;  $P < 0.05$ ; Table 1) with 44.5% of all OD in the Wallis and 63.6% in Tyrol showed  $L_{eq8h}$  values of more than 80 dB(A). Compared with EC 135  $L_{eq8h}$  was significantly higher in Bk 117 ( $P < 0.0001$ ; Table 1). The mean  $L_{eq8h}$  of Alouette II ‘Lama’ was 100.1 dB(A) and differed significantly from EC 135 and Bk 117 ( $P < 0.0001$ ; Table 1). With 98.4 dB(A) the  $L_{eq8h}$  of Alouette IIIb differed significantly from all the types mentioned above ( $P < 0.0001$ ; Table 1). Ecureuil showed mean Leq8h of 92.8 dB(A), which is highly significantly different to all the other types except Sea King ( $P < 0.0001$ ; Table 1), and Bell UH 1D those of 86.8 dB(A) (Table 1). Sorted by noise exposure the least noisy of these standard rescue helicopters is EC 135 whereas the noisiest of those types which are still in operation is Alouette II (Fig. 4). Data for the other helicopter types, calculated with the noise levels given in Table 2 are given in Table 1. No data could be obtained from Bell 412, Agusta 109, and Dauphin, which are in operation at some rescue bases.

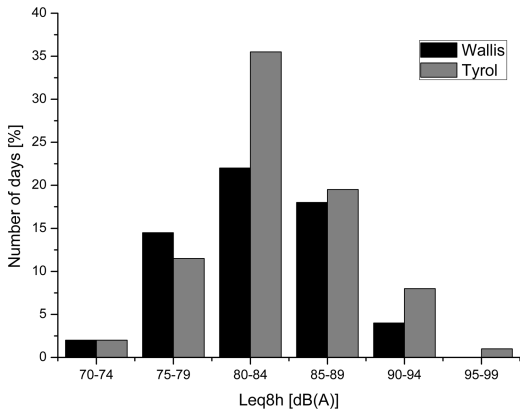

Fig. 3. Daily noise exposure (Leq 8h) for EC 135 (days with rescue operations only).

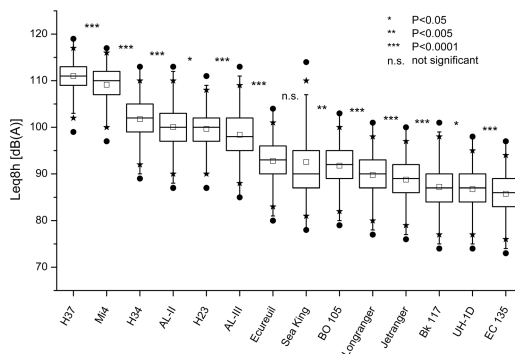

Fig. 4. Daily noise exposure as equivalent noise exposure (Leq 8h) for several helicopter types (days with rescue operations only).

Table 1. Noise exposure of the personnel, assumed that the same operations were performed with the respective type of aircraft

Aircraft	Mean Leq8h (+/-Sx; range)			Operational days with Leq8h >85 dB(A) [%]		
	All airbases	Tyrol	Wallis	All airbases	Tyrol	Wallis
EC 135	85.8 (4.0; 73–97)	86.1 (3.9; 73–86)	85.4 (4.1; 74–97)	75.7	77.5	74.3
Ecureuil AS350B	92.8 (4.0; 80–104)	93.1 (3.9; 80–103)	92.3 (4.1; 81–104)	98.2	98.2	98.2
Alouette II	100.1 (4.4; 87–113)	100.4 (4.3; 87–112)	99.6 (4.5; 88–113)	100	100	100
Alouette IIIb	98.4 (4.8; 85–113)	98.8 (4.8; 85–111)	98.0 (4.9; 86–113)	100	100	100
Bk 117	87.2 (4.6; 74–101)	87.6 (4.5; 74–79)	86.8 (4.6; 75–101)	83.4	82.1	87.8
UH 1D	86.8 (4.0; 74–98)	87.1 (3.9; 74–97)	86.3 (4.1; 77–100)	84.1	83.1	88.8
Bell 206 B Jetranger	88.8 (4.0; 76–100)	89.1 (3.9; 76–99)	88.3 (4.1; 77–100)	89.8	90.8	88.8
Bell 206 Longranger II	89.8 (4.0; 77–101)	90.1 (3.9; 77–100)	89.3 (4.1; 78–101)	93.2	94.0	92.4
Sea King	92.6 (7.5; 78–114)	92.9 (7.5; 78–112)	92.2 (7.5; 79–114)	94.1	94.3	93.9
BO 105	91.8 (4.0; 79–103)	92.1 (3.9; 79–102)	91.4 (4.1; 80–103)	93.4	93.6	93.1
Mi-4	109.1 (3.5; 97–117)	109.5 (3.3; 92–117)	108.7 (3.6; 98–117)	100	100	100
Sikorsky H-23/UH12	99.7 (3.9; 87–111)	100.0 (3.8; 87–109)	99.2 (4.0; 88–111)	100	100	100
Sikorsky H-34	101.8 (4.0; 89–113)	104.1 (3.9; 89–112)	101.3 (4.1; 90–113)	100	100	100
Sikorsky H-37 Mojave	111.0 (3.4; 99–119)	111.3 (3.2; 99–118)	110.6 (3.6; 100–119)	100	100	100

Sx: SD

Table 2. Noise levels of other helicopter types

Aircraft	Noise level [db(A)]		Reference
	inside	outside	
Bell 206 B Jetranger	97	(107)*	(House 1975)
Bell 206 Longranger II	98	(108)*	(Pasic and Poulton 1985)
BO 105	100	(110)*	(Koch and Koch 1990)
Mi-4	118	121	(Lorenz and Demus 1965), (Rood and Glen 1977), (Owen 1995)
Sea King	98,4	121	(Schlegel <i>et al.</i> , 1966), (Quémerais 2008)
Sikorsky H-23/UH12	108	117	(Rood and Glen 1977), (Owen 1995)
Sikorsky H-34	110	120	(Rood and Glen 1977), (Owen 1995)
Sikorsky H-37 Mojave	120	120	(Hatfield and Gasaway 1963)

\*Data in brackets had to be estimated since no exact data comparable to ours are available.

## DISCUSSION

The study investigates the effect of advanced noise-reducing helicopter constructions on the noise exposure and therefore the risk for noise-induced hearing loss of the personnel of crews in alpine helicopter rescue organizations. A special problem in alpine helicopter rescue is that there is still no helmet available which could provide adequate hearing protection, but which also enables communication on ground at the site of emergency when a winch operation is performed and which also fulfils the requirements of aviation helmets and those of mountaineering helmets (DIN EN 12 492 (DIN, 2000)). Since alpine dangers are more important than those caused by aviation (Durrer, 1993; Shimanski, 1998) most rescuers use mountaineering helmets for winch operations. They give a good protection against falling stones and ice and allow a perfect communication, but give no

protection against noise. The additional use of headsets with such helmets is limited as their earplugs do not fit well under the helmet and even minor leakages cause significant increase of noise exposure. With significant less noisy helicopter constructions and an average duration of winch operations of only about 3 min the crews could conclude that such a short exposure by their 'silent' helicopter does not harm their hearing ability. Consequently they may ignore that noise protection is still necessary, although the latest constructions show significant minor noise levels and the combination of noise protection, communication and protections against environmental risks (e.g. falling stones or ice) is still a problem.

Several investigations about the correlation between aviation noise and hearing damage have been published. Most of them proved the number of flying hours or the total years of flying as independent risk (e.g. Peters and Ford, 1977 and 1983; Edington

and Oelmann, 1982; Ribak *et al.*, 1985; Matschke, 1987; Fitzpatrick, 1988; Jones, 1988; Wu *et al.*, 1989). Others did not find such a relation (Pasic and Poulton, 1985), but they investigated interhospital transfer with less noisy helicopters only. However, a comparison of the different investigations is difficult because of the numerous confounding factors (Owen, 1995). However, the exposure in alpine rescue mainly depends on the type of helicopter used, the total flying time (regional differences (distances), numbers of rescues per day), the amount of winch operations, and hot loading.

In contrast to noise by airliners and to those of most other industrial noise exposure there is an important difference in the distribution of the exposure. Whereas typical airliner or industrial noise is limited at about 70–90 dB(A) and lasts for a typical shift or flight, the exposure during alpine rescue is at much higher levels up to 120 dB(A)—and sometimes even more—and extremely seasonal. Although there are days or even weeks in May or November where there are only some operations, the crew is sometimes exposed to extreme levels for 12 or more hours during high season where sometimes there is even no pause between several rescue operations. A limited exposure to such noise levels may first cause a temporary threshold shift. As our data show, even the less noisy days of rescue operation are at the range of 80–85 dB(A)  $L_{eq8h}$ . Such exposure needs an adequate period of silence (at least <60–65 dB(A), which is equivalent to speech), but because the next alarm follows too quickly this is rarely possible. An adequate protection is possible with intelligent shift plans of the personnel, but this needs more than one team. Whereas pilots and rescuers are available for such shift plans at most airbases this is not true for physicians, e.g. the two Swiss bases at Zermatt and Raron operate with one physician only who is at the base from sunrise to sunset and on call during night. Such persons are at high risk to develop permanent threshold shifts.

Since the early 1990s the helicopter types most often used have changed a lot. Whereas Longranger was very popular in the USA and other countries, Ecureuil was often operated in Europe. As our data show this was not only of advantage for the rescue operation and the transport of the patient to the hospital because of their higher maximum speed, they also caused less noise exposure to the personnel. However, it is difficult to estimate the realistic amount of noise exposure when personnel claim that their hearing loss is an occupational disease and when they have worked with several types of helicopters. With nearly all types of helicopters which

ever were in operation for rescue purposes at altitude a more direct comparison of the different exposures is possible (Table 1). This should facilitate the expert's work and provide a more correct decision about occupational hearing loss of rescue personnel.

Whenever the EC 135 is used, this noise exposure is even lower. In fact, this type was the most silent aircraft investigated. Although helicopter noise is only about 1/10000 of the whole aircraft's power, it is a source of noise of enormous intensity (Kloppel *et al.*, 1993). For noise protection it is important to consider that helicopter noise has several components which all together sum up to the high exposure of the personnel: (i) periodic 'rotational noise' of low frequency; (ii) stochastic 'vortex noise' with frequencies >200 Hz and a spectrum more continuous than that of rotational noise; (iii) some constant peaks at high frequencies, caused by the transmission, turbine and other parts (Heinig, 1971; Laudien, 1976; Laudien and Huber, 1977); and (iv) impulse components caused by vacuum phenomena if the rotor tips are at supersonic velocity or when the vortices of the main rotor are cut by the tail rotor ('tail to main interactions'). Advanced constructions reduced the impact of several components, e.g. the design of the lade tips were changed. The most important effect was realized by new tail rotor designs which avoid main rotor vortices being cut (encapsulated rotor) and an asymmetric rotor construction (Fig. 5). The latter causes an enormous noise reduction by phase modulation.

Like all the other investigators, we have regarded the time between flights as being quiet, without risk of hearing loss, but this is not realistic, as



Fig. 5. Asymmetric and encapsulated Fan-in-Fin-Rotor Fenestron® heck rotor of EC 135.

several authors point out [concerts, portable stereo use, etc. (Babisch *et al.*, 1988; Ising *et al.*, 1988; Krahenbuhl *et al.*, 1988; Babisch and Ising, 1989; Esser, 1992; Matschke, 1993). Another topic was rarely discussed: the combined effect of noise and hypoxia. Typically alpine rescue takes place at altitudes between 2500 and 4600 m (Küpper, 2006). At these altitudes oxygen pressure is reduced by a third (Ruff and Strughold, 1944; Muller, 1967; Ernsting and King, 1988; Küpper *et al.*, 2010). Hearing is an active, energy consuming process and this energy is provided inside the cochlea over a relatively long diffusion distance. In hypoxic conditions this may become critical. Experiments with animals have shown that there is a significant reduction of cochlear perfusion after exposure to 85 dB(A) for 6 h (Attanasio *et al.*, 2001). Other investigations found such an effect at higher levels only (>100 dB(A)), but then linearly correlated to increasing sound levels and to the decrease of the perilymphatic oxygen partial pressure (Lamm and Arnold, 1996). Both effects lasted for of 1 h after the noise exposure was finished. A complete recovery was reached after 3 h. Another study animals showed a temporary threshold shift after an isobaric exposure to 6% oxygen, which corresponds to an altitude of about 10 500 m (Attias *et al.*, 1990). The finding that acclimatized animals showed significantly lesser hearing impairment supports the thesis of a combined effect of hypoxia and noise (Berndt *et al.*, 1978). Humans in isobaric conditions and with an arterial oxygen saturation of 74% (approximately corresponding to an altitude of 4500–5500 m) showed significant temporary shifts of the hearing threshold (Fowler and Grant, 2000). It was never investigated, but these effects indicate that the thresholds given for safe work in noisy environments may not be safe for personnel working in hypoxic conditions as crews of alpine helicopter rescue services do.

Another topic we did not include in our study like other authors is the communication by the intercom system of the aircraft or via radio to the ground personnel during winch operations. This communication causes a further increase in noise exposure by +3–6 dB(A) (Glen and Moorse, 1977; Wolf *et al.*, 1988; Owen, 1995). As an impressive example in a previous paper (Küpper *et al.*, 2004) shows, perfect communication is crucial for safety and therefore this noise cannot be avoided.

However, although our data show that advanced helicopter constructions cause a significant decrease of noise exposure, the crews of alpine rescue operations are still at high risk for permanent hearing damage.

Physicians and winch operators are at highest risk of all. The risk should be minimized by the consequent use of hearing protection devices. Where helmets or headsets with a noise reduction of at least 25 dB(A) cannot be used at least earplugs should be applied. While the helicopter approaches, the patient (if he or she is still able to do so) and the persons who are incidentally at the site should protect their ears with their hands. With regard to hearing damage one of the most dangerous situations is the so-called ‘hot-loading’, a manoeuvre which is performed in about 2% of all missions (Küpper, 2006). During this manoeuvre the helicopter puts just one skid to the ground and hovers with the engine(s) running at full power and patient, equipment and crew are loaded. The duration of hot-loading is on average 3 min, which means that the recommended limits of exposure are exceeded 25-fold during this moment. Such a manoeuvre should never be started without adequate hearing protection of anybody involved. All personnel involved in helicopter rescue operations should be regularly checked by occupational medicine, e.g. according to the German regulation ‘G20’ (Noise-induced Hearing Damage, (DGUV, 2010)).

## CONCLUSION

Advanced rotor and engine technology of modern helicopters significantly reduce noise exposure of the personnel. Although adequate hearing protection in alpine rescue is still a technical problem and the exposure during winch operations lasts for some minutes only, it is still not acceptable to abstain from protection devices. With (nearly) all helicopter types included in the same model to estimate the personnel’s noise exposure, a more direct comparison of the with and a more exact estimation of the total exposure of a person who has been working at several types is possible.

*Acknowledgements*—A warm ‘thank you!’ to the crew of the ADAC helicopter ‘Europa 1’ at Merzbrück/Germany, especially Carsten Zillgen (Pilot), Sven Mainz (Air base commander) and all the other team members. Master Sergeant Mark Birkelbach (NATO airbase Nörvenich/Germany) supported us to study the noise of UH1-D. Lutz Richter assisted us to convert the data from the measuring device to statistic software. We would also like to thank Air Zermatt AG (Zermatt and Raron) and the air rescue bases at Innsbruck and Landeck (Prof. Dr Flora) for their support. No conflicting interests are declared.

## REFERENCES

- Attanasio G, Buongiorno G, Piccoli F *et al.* (2001) Laser Doppler measurement of cochlear blood flow changes during conditioning noise exposure. *Acta Otolaryngol*; 121: 465–9.

- Attias J, Sohmer H, Gold S *et al.* (1990) Noise and hypoxia induced temporary threshold shifts in rats studied by ABR. *Hear Res*; 45: 247–52.
- Babisch W, Ising H, Dziombowski D. (1988) Einfluß von Diskothekenbesuchen und Musikgewohnheiten auf die Hörfähigkeit von Jugendlichen. *Z Lärmbekämpfung*; 35: 1–9.
- Babisch W, Ising H. (1989) Zum Einfluß von Musik in Diskotheken auf die Hörfähigkeit. *Soz Präventivmed*; 34: 239–242.
- Berndt H, Kranz D, Wagner H *et al.* (1978) [Hair cell noise damage after improved hypoxia tolerance (author's transl)]. *Laryngol Rhinol Otol* (Stuttg); 57: 520–3.
- Deutsche Gesellschaft für Arbeitsmedizin und Umweltmedizin e.V. (2010) Arbeitsmedizinische Vorsorge [Prevention in Occupational Medicine]. Stuttgart: Gentner Verlag.
- Deutsches Institut für Normung e.V. [German Institute for Standardization]. (1994) DIN/EN 60651; IEC 651: Schallpegelmessgerät [Noise measure equipment]. Berlin: Beuth Verlag.
- Deutsches Institut für Normung e.V. [German Institute for Standardization]. (1997) DIN 45645-2 Ermittlung von Beurteilungsspegeln aus Messungen [Calculation of equivalent noise level from measurements]. Berlin: Beuth Verlag.
- Deutsches Institut für Normung e.V. [German Institute for Standardization]. (2000) DIN EN 12492 Bergsteigerausrüstung: Bergsteigerhelme - Sicherheitstechnische Anforderungen und Prüfverfahren [Climbing equipment: helmets]. Berlin: Beuth Verlag.
- Deutsches Institut für Normung e.V. [German Institute for Standardization]. (2003) DIN ISO 5129 Messung des Schalldruckpegels in Luftfahrzeugen während des Fluges [In-flight measurement of noise levels in aircrafts]. Berlin: Beuth Verlag.
- Durrer B. (1993) Rescue operations in the Swiss Alps in 1990 and 1991. *J Wilderness Med*; 4: 363–73.
- Edington K, Oelmann BJ. (1982) An audiometric survey of army aircrew. International Report. Middle Wallop/England: HQ Director Army Air Corps.
- Ernsting J, King P. (1988) Aviation medicine. 2nd edn. London: Butterworth.
- Esser L. (1992) Da geht die Post ab—Lärmbelastung Jugendlicher in Beruf und Freizeit. *Hörakustik*; 27: 4–14.
- European Union. (2003) Directive 2003/10/EC of the European Parliament and of the Council of 6 February 2003 on the minimum health and safety requirements regarding the exposure of workers on the risk arising from physical agents (noise) (Seventeenth individual Directive within the meaning of Article 16(1) of Directive 89/391/EEC). Official J European Union; L42: 38–44.
- Fitzpatrick DT. (1988) An analysis of noise-induced hearing loss in army helicopter pilots. *Aviat Space Environ Med*; 59: 937–41.
- Fowler B, Grant A. (2000) Hearing thresholds under acute hypoxia and relationship to slowing in the auditory modality. *Aviat Space Environ Med*; 71: 946–9.
- Glen MC, Moore SA. (1977) The contribution of communication signals to noise exposure. Royal Aircraft Establishment Technical Report 77027. London: HMSO.
- Hatfield JA, Gasaway DC. (1963) Noise problems associated with the operation of US Army aircraft. Fort Rucker, Alabama/USA: United States Army Aeromedical Research Unit.
- Heinig K. (1971) The periodic component of the rotor and propeller sound. Tullahoma/USA & Aachen/Germany: Messerschmitt-Bölkow-Blohm; 15.3. & 29.3.-3.4. Report No.: 11/II-1.
- House JW. (1975) Effects of helicopter noise on pilot's hearing. *Trans Pac Coast Otolophthalmol*; 56: 175–86.
- Ising H, Babisch W, Gandert J *et al.* (1988) Hörschäden bei jugendlichen Berufsanfängern aufgrund von Freizeitlärm und Musik. *Z Lärmbekämpfung*; 35: 35–41.
- Jones DG. (1988) An audiological survey of aircrew. *J R Nav Med Serv*; 74: 496–502.
- Kloppel V, Lowson MV, Fiddes SP *et al.* (1993) Theoretical studies undertaken during the Helinoise Programme. In: 19th European Rotorcraft Forum; Cernobbio/5.
- Koch J, Koch C. (1990) Schwingungsbelastungen: Das geeignete Rettungsmittel. *Notfallme*; 16: 491–5.
- Krahenbuhl D, Arnold W, Fried R *et al.* (1988) Hörschäden durch Walkman? *Laryngol Rhinol Otol*; 66: 286–9.
- Küpper T, Steffgen J, Jansing P. (2004) Noise exposure during alpine helicopter rescue operations. *Ann Occup Hyg*; 48: 475–81.
- Küpper T. (2006) [Workload and professional requirements for alpine rescue.] Professoral Thesis. Aachen: RWTH Aachen Technical University.
- Küpper T, Milledge JS, Hillebrandt D *et al.* (2010) Occupational Aspects of Work in Hypoxic Conditions—the new Recommendation of the Medical Commission of the Union Internationale des Associations d'alpinisme (UIAA MedCom). *Med Sport*; 14: 34–9.
- Lamm K, Arnold W. (1996) Noise-induced cochlear hypoxia is intensity dependent, correlates with hearing loss and precedes reduction of cochlear blood flow. *Audiol Neurootol*; 1: 148–60.
- Laudien E. (1976) Main and tail rotor interaction noise during hover and low-speed conditions. In: 2nd European Rotorcraft and Powered Lift Aircraft Forum; 10. Sep. 1976. Bückeburg.
- Laudien E, Huber H. (1977) Impulsive helicopter rotor noise. In: 2. GARTEur-5 Specialist Meeting on 'Propeller and Helicopter Noise'; 1.-2.6.1977. Paris.
- Lorenz W, Demus HG. (1965) Lärmprobleme beim Hubschrauberkrankentransport. *Verk Med*; 12: 525–32.
- Matschke RG. (1987) [Risk of noise-induced hearing loss caused by radio communication? Audiologic findings in helicopter crews and pilots of propeller airplanes]. *Hno*; 35: 496–502.
- Matschke RG. (1993) Gehörschäden durch nichtberuflichen Lärm. *Dt Arztebl*; 90: A1 2240–2.
- Muller B. (1967) Die gesamte Luftfahrt- und Raumflugmedizin. Düsseldorf: Droste Verlag.
- Owen JP. (1995) Noise induced hearing loss in military helicopter aircrew—a review of the evidence. *J R Army Med Corps*; 141: 98–101.
- Pasic TB, Poulton TJ. (1985) The hospital-based helicopter—a threat to hearing? *Arch Otolaryngol*; 111: 507–8.
- Peters LJ, Ford H. (1977) Extent of hearing loss among army aviators at Fort Rucker, Alabama. US Army Aircraft Establishment Technical Report 77027. London: HMSO.
- Peters LJ, Ford H. (1983) Extent of hearing loss among army aviators at Fort Rucker, Alabama. Fort Rucker, Alabama: U.S. Army Aeromedical Research Laboratories.
- Quémérais B. (2008) Effect of the new insulation liner on noise levels in the CH124B (Sea King) aircraft. Toronto: Defence Research and Development Canada.
- Ribak J, Hornung S, Kark J *et al.* (1985) The association of age, flying time, and aircraft type with hearing loss of aircrew in the Israeli Air Force. *Aviat Space Environ Med*; 56: 322–7.
- Rood GM, Glen MC. (1977) A survey of noise doses received by military aircrew. Technical Report No.77080. London: HMSO.
- Ruff S, Strughold H. (1944) Grundriss der Luftfahrtmedizin. 2. Aufl. ed. Leipzig: Johann Ambrosius Barth.
- Schlegel R, King R, Mull H. (1966) Helicopter rotor noise generation and propagation. Fort Eustis, Virginia/USA: U.S. Army Material Laboratories.



- Shimanski C. (1998) Risks in mountain rescue operations. *Wilderness Medical Letter*; 15: 6–8.
- Wolf C, Ebm W, Cichini G. (1988) Die Lärmbelastung von Fluglehrern und Privatpiloten. *Arbeitsmed Sozialmed Präventivmed*; 23: 88–90.
- Wu YX, Liu XL, Wang BG *et al.* (1989) Aircraft noise-induced temporary threshold shift. *Aviat Space Environ Med*; 60: 268–70.