



THE INSTITUTE OF CHARTERED ACCOUNTANTS OF NIGERIA

(Established by Act of Parliament No 15 of 1965)

1st Academic Conference of Accounting and Finance

2015 CONFERENCE PROCEEDINGS

Contents

DISCLAIMER 7

PREFACE 8

LEAD PAPER :

What is the purpose of Accounting Research – to Improve Accounting Practice or Simply to Enrich Literature?

Professor Kabiru Isa DANDAGO 11

PAPERS PRESENTED

ACCOUNTING EDUCATION

Effect of Teaching Methods in the Performance of Accounting Students' in Benson Idahosa University in Nigeria: **OBASI RoseMary O., URRHOGHIDE Ruth O. & ARCHIBONG Comfort** 27

AUDIT, ASSURANCE AND CORPORATE GOVERNANCE

Accountancy Professional Ethics and Assessment of Compliance Level by the Nigerian Auditors: **ABUH Adah & SAMAILA Thompson** 47

Pushing for Joint Audit in Nigeria

JINADU Olugbenga, OJEKA Stephen Aanu & AGBEYANGI Babatunde Adisa 61

Internal Audit Characteristics and Quality of Accounting Information in Nigeria:

OGUNDANA Oyebisi, OJEKA Stephen; OJUA Michael & NWAZE Chukwu 82

Corporate Governance and Audit Quality

OKARO S.C., OKAFOR G.O. & OKOYE E. I 102

The Effectiveness of Audit Committees in Nigerian Banks: Implications on the Quality of Financial Reporting:

MBOBO Erasmus Mbobo & AUSTINE Nweze 122

Pricing of External Audit Services in Nigeria: A Dynamic Analysis
SOYEMI Kenny Adedapo 157

The Effect of Regulatory Framework on Auditors' Independence in
Nigeria **WRIGHT Olatunde** 173

BANKING AND INSURANCE

Firm's Attributes and the Financial Performance of Nigerian Deposits
Money Banks: **ABUH Adah & SAMAILA Thompson** 198

Information Technology Human Capital Development: Nigerian
Banking Industry Experience:
ADEGBOYEGA R.A. & AKINDE, M.A 212

Efficiency and Financial Distress Prediction in the Nigerian Banking
Industry: **AYOOLA, J.T. & AYORINDE, A. A** 236

Extent of Compliance with Islamic Financial Accounting Standards by
JAIZ Bank, Nigeria: **LAWAL, R. & DANDAGO, Kabiru. Isa.** 261

ALMAN's Z-Score Discrimination Analysis and Bankruptcy Assessment
of Banks in Nigeria: **Nwidobie, M.A.** 277

Influence of Forensic Accounting on Fraud Detection and Prevention
in Nigeria Banking Industry: **Salman, A.Y. ,
Lawal A. A. & Anjorin S.Y.** 294

The Effects of Ownership Concentration and Board Committees on
Financial Performance: Evidence from Turkish and Nigerian Listed
Companies: **SENER Irge** 307

Foreign Directors in the Boardroom and Financial Performance of
Listed Deposit Money Banks in Nigeria: **SALAMI Suleiman & RAMLAT
Muhammed Oche** 327

Impact of MacroEconomic Factors on NoN-Performing Loans in the
Nigerian Deposit Money Banks: **YAHAYA, Khadijat Adenola & ONI,
Opeyemi Oluwasegun** 346

Determinants of Motor *Takaful* Patronage among Commercial
Vehicle Operators: A Conceptual Review: **YAQUB, Habiba Ali &
DANDAGO, Kabiru. Isa.** 368

CORPORATE REPORTING

Environmental Accounting Practice; Benefits, Challenges and the Way Forward: **AFROGHA, O. O** **395**

Implications of Carve-Outs in Adopting IFRS as global Accounting Standards: **AGHIMIEN, P., MACDONELL, D. JIA, X. & FU, Y.** **413**

International Financial Reporting Standards (IFRS) Transplanting and Convergence in Nigeria: Consequences and Prospects, **AKINDE, M. A. , AFOLABI Adegboyega & AMUSA, N. A** **437**

Environmental Management Accounting Techniques and Quality Financial Reporting in Nigeria: **ANYANWU, N.** **456**

Impact of Legal System on International Financial Reporting Standards (IFRS) Adoption in African: **EMENI, F.K. & IYOHA, F. O** **481**

The Economics of Heterogeneity: InterDisciplinary Corporate Boards and Firm Performance- **Ilaboya, J.O.** **516**

Convergence to Heterogeneity Financial Reporting Standards(IFRS) and Global Consistency: **PEACE Ebunoluwa Kolawole** **539**

Social and Environmental Issues in Nigeria: Are Corporate Entities in Nigeria Showing Concern?: **MAMIDU,A. I., ADETULA,S.L. & ABU, J. A** **565**

Impact of Corruption in Nigerian Stock Market: **NAGERI, K.I.** **581**

Board Attributes and Corporate Financial Performance of Nigerian Quoted Companies: **RUTH O. Urkoghide & AUGUSTINE. E. Akhidime** **595**

Corporate Board Structure and Earning Management of Listed Cement Companies in Nigeria: **Samai'la, I. A. & Zaharaddeen, A.** **615**

The Value –Relevance of Accounting Information in Nigeria: The Perception of Accountants in the IFRS Regime. **644**

ETHICS

Implication Of Accountants` Unethical Behavior And Corporate Failure: **ESHIET, U.E** **671**

Ethical Issue about Creation Accounting: Theoretical And Practical Perspective: **FADIRAN Taiwo Phebe & ALAKA Abayomi Ambali** **694**

FINANCE

Determinants of Dividend Policy of Corporate Firms in Nigeria
Adelegan, O.J., Adeyemo, K.A. ,Adejuwon J.A. & Taiwo, A.O **720**

Managerial Ownership And Dividend Payout Policy In Nigerian Listed Non-Financial Firms: **KAJOLA, S.O. & Adewunmi , A. A.** **742**

The Impact of Dividend Policy on the Share Price of Selected Quoted Firms In Nigeria: **SALMAN, A.Y., LAWAL, A. A. & ANJORIN, S.Y.** **772**

The link Between Oil Price Fluctuations and the Manufacturing Sector Performance in Nigeria: **UGURU Leonard C.** **795**

The Effect of Human Capital Investment on Corporate Performance: A Cross Sectional Study Of Selected Quoted Companies In Nigeria.
UZOAMAKA Ernest Chhinerugo **815**

MANAGEMENT ACCOUNTING

Significance of Human Capital to Organisational Value Creation
ADELOWOTAN M.O. & OLAOLUNIYI O. **831**

Impact of Activity-Based Costing Implementation On Performance Of Selected Manufacturing Firm In Kwara State, Nigeria:
ADEGBOLE, Ezekiel A. & OLUDOYI S.B. **854**

Working Capital Management And Profitabilty of Small And Medium Enterprises (SMES) In Nigeria: **AGBEYANGI ,B.A. ,Jinadu, O. & AKINDE, M.A.** **884**

Cost-Earning Sensitivity Analysis And Measurement of Returns to Investment In Physicians' Residency Programme in Nigeria: **ALOZIE, C.E. & Nwaorgu, I. N.** **901**

Board Structure, Ownership Structure and Financial Performance of Manufacturing Firms in Nigeria: **ENAKIRERHI, L. I.** **932**

Militating Effect Of Inventory Management And Control In The Manufacturing Industry: A Case Study of Classic Beverges Nigeria Limited Lagos: **ONYEBUENYI, F. E.** **951**

The Impact of Flexitime and Compressed Workweek on Job Scheduling And Performance of Accounting and Finance Professional: **OSHADARE Segun Anthony** **969**

PUBLIC SECTOR ACCOUNTING

Impact of Compliance With Federation Account Allocation Committee Guidelines on the Financial Reporting of Kano State Government **HANNATU Sabo Ahmad & KABIRU Isa Dandago** **987**

Moderating role Of Organisational Culture on the Relationship Between Budgetary Participation and Organisational Performance In Federal Universities Across Nigeria: **AKINNIYI, K.O., AJIBOLADE, S.O. , FAGBEMI, T.O. & ASHOGBON, F.O.** **1011**

Impact of Knowledge of Forensic Accounting Service on Fraud Prevention in the Nigerian Public Sector: **AHMAD Imam, AHMED,Modu Kumshe & MUSA Garba Gulani** **1026**

Fiscal Responsibility Act (FRA) and Its Implication on the Performance of Public Sector Accountants. **KOLAWOLE Peace E.** **1039**

Impact of Education Sector Financing on the Welfare of the Welfare of Nigerians: **OGBOLE Friday Ogbale & SAMSON Adeniyi Olajare** **1065**

TAXATION

- Effects Of Tax Control Measures on Collectable Tax Revenue From Companies in Borno and Yobe States, Nigeria: **BABA Yagaya Alhaji & AHMED Modu Kumshe** 1095
- Do Tax Incentives Determine Foreign Direct Investment In the Nigerian Oil and Gas Sector: **BABATUNDE Shakirat Adepeju & YOHANA Gyangjugu** 1109
- Tax Revenue and Economic Growth In Nigeria From 1980-2013 **ETIM Osim Etim & Austin Nweze** 1135
- Effect Value Added Tax and Economic Growth in Nigeria. **FASINA H TAIWO & ADEGBITE TAJUDEEN ADEJARE** 1163
- Tax Management and Economic Growth of Nigeria **LAWAL, I.** 1175
- Personal Income Tax and Enterprenueurial Development in Ogun State, Nigeria: **OLABISI Jayeola, OLADUNJOYE, T. Olawale & BABATOLU, A. T.** 1193

DISCLAIMER

This document is a compendium of the Academic Conference of Accounting and Finance, organized by the Institute of Chartered Accountants of Nigeria at the Lagos Airport Hotel between the 18th and 20th of May 2015. **The articles are as submitted by the authors, and have not been reviewed.** The errors in the articles are the authors'.

PREFACE

The quality of corporate decisions and by extension, business performance, is driven by timely access to quality information provided by Accounting professionals. Such information must consistently meet the acid test of reliability, credibility, objectivity and timeliness to be useful. As the science that thrives on scientific projections and estimates, Accounting will remain a business enabler if the information it generates meets those characteristics. Here lies the propriety for investments in processes or activities that will ensure the gathering of accurate data, their conversion to quality information which, when consolidated with the help of relevant standards, become meaningful and credible financial statements. It is no wonder therefore that, in today's world, quality information is the most critical business resource.

Part of the statutory responsibilities of the Institute of Chartered Accountants of Nigeria is to set and review standards from time to time in line with the dynamics of the business environment. At the heart of this mandate are environmental scanning and information gathering, through scientific processes, on developments that can impact the practice of accountancy and financial reporting. It is in pursuance of this that the Institute encourages and financially supports commissioned and doctoral research efforts not only of its members in academia, industry and practice but also of others who are research inclined. The goal always is to stretch existing best practices to new heights of excellence.

Thus, the output of these scholarly works often assist the Institute to intelligently review processes for the development, issuance and/or re-issuance of standards and practice statements such that the quality, credibility and reliability of financial statements are sustained in the public interest. Since professional accountants operate in a knowledge-driven environment, investment in research, in this manner, is much more than commitment to corporate social responsibility. It is a market-leadership and pacesetting strategy. In any case, since the absence of quality information can result in poor

decisions and ultimately business failure, investment in research is therefore a fait accompli

In order to further leverage the research window for the expansion of the frontier of knowledge in Accounting and related fields, the Institute's governing Council graciously approved the holding of an Annual Academic Conference. The Conference was conceptualized to provide a platform for its members and other researchers from various tertiary institutions to exchange ideas and share knowledge on current developments in the Accountancy Profession and allied disciplines. The inaugural edition was held from 18-20, 2015 in Lagos under the auspices of ICAN Research Foundation.

The initiative was deeply encouraged by the growing number of professional accountants in academics, a development which is helping to bridge the gap between the town and gown. Since knowledge has become the most important asset of organizations and even nations, interaction between industry and the ivory tower will, no doubt, enrich the quality of business information and ultimately, the growth and prosperity of corporate entities. The synergy of such cooperation is expected to be invaluable and beneficial to diverse stakeholders.

This First Academic Conference, which was wholly financed by the Institute, provided an opportunity for researchers not only to discuss their current research findings with their peers but also apprise themselves of new research methodologies. Based on feedback received, comments on abstracts by participants, significantly provided new and better insights into ongoing research efforts. When published, such research efforts will hopefully expand and add to the subsisting body of knowledge in those areas.

Attended by 110 participants drawn from all tertiary institutions in Nigeria and diaspora, the Conference was moderated by two acknowledged academics: Prof. Abhulimen R. Anao, FCA, Professor of Accounting and former Vice Chancellor, University of Benin and Prof. Isa Dandago, FCA, Professor of Accounting, Ado Bayero University, Kano. Their brilliant lead presentations set the tone for the

conference. It will not be immodest to attribute the success of this inaugural Academic Conference to their ebullience.

The point must be made that this initiative is not a flash in the pan. It is a continuation and consolidation of the efforts made in 2002 by the Institute when it organised a workshop on Research Design and Methodology for teachers of Accounting and Allied subjects in order to hone their skills in research pedagogy. Interestingly, Prof. A.R. Anao, FCA was one of the propelling forces behind that ICAN effort several years ago. Hopefully, this will be sustained on annual basis, *ceteris paribus*.

This publication is the outcome of the First Annual Academic Conference. To make for easy reading and harmony of thoughts, its content has been segmented into four core areas of Accounting as follows: Ethics, Finance, Managing Accounting and Corporate Reporting. These are not watertight compartments as they all draw from the existing body of Accounting knowledge. I trust that readers will find them informative enough to encourage them to attend subsequent Academic Conferences without prompting. There is a lot to learn from the pot pourri of ideas in this edition.

While commending the governing Council for approving the holding of this Conference, I salute the Institute for its sustained interest in accounting research, and its members in academics, for leveraging the opportunity to contribute to the expansion of the subsisting body of knowledge in the various aspects of Accountancy.

Finally, I commend this publication to all professionals.

Abel Aig. Asein

Deputy Registrar, Technical Services

KEYNOTE PAPER

What is the Purpose of Accounting Research – to Improve Accounting Practice or Simply to Enrich Literature

Prof. Dandago Kabiru Isa, FCA

Introduction

This keynote address is essentially a commentary. I would like to use it as a means to r agitate our minds as teachers and researchers on the vital issue of whether our research efforts actually do produce the desired results, measured in terms of their impact on the accountants' work. From time to time for some decades now, some accounting thinkers have come up with the proposition that accounting researches may not actually be making any impact on the practice of accounting; that there seems to be a divergence between accounting research and accounting work. These views are held by eminent scholars such as Tricker (1978), Demski (2001), Baxter (1999), Carsberg (1997), Ijiri (1975), Belkaoui (1977), etc. What motivates me to draw attention to this issue this morning, however, is what I myself see as a growing trend which confirms the views expressed by those scholars and again recently echoed by Inanga and Schneider in their 2005 article in *Critical Perspectives in Accounting* titled: ***The failure of accounting research to improve accounting practice: a problem of theory and lack of communication***. Their article takes the very emphatic position that there is a wide divergence between accounting research and accounting practice. They aver that: Accounting research or what is alleged to be research is of little value to the practice of accounting, nor to the development of accounting as an academic discipline. The problem is not that efforts have not been made to conduct research, but rather there is a fundamental flaw in the accounting research process itself.

This assertion must come to many as a surprise if not bewilderment because it challenges the very foundation on which we

accounting researches stand, and which forms the rationale for much of what we do as accounting teachers and researchers. In this address I wish to focus attention on the issues raised by not only Inanga and Schneider but also others before them who pointed to the possible lack of any relationship between what accounting scholars research in and what accountants out there in the field actually do. I propose that we examine the validity of this assertion on the basis of our own experience here in Nigeria in order to confirm or disaffirm it. If confirmed we would go further to contribute views as to a possible approach to changing the situation.

The apparent reasons for the alleged divergence which appear in the literature are summarised as follows:

- (i) Accounting research is not significantly linked to accounting practice because the issues of interest to academic researchers are of little or of no consequence to practitioners.
- (ii) Accounting practitioners tend to be married to the systems and methodologies which are dictated by the relevant standard setting authorities;
- (iii) Practising accountants scarcely find it necessary or have the time to familiarise themselves with the products of accounting research.
- (iv) The concern in formulating accounting undergraduate curriculum is to produce graduates who can be immediately useful in the work place after graduation, and not necessarily what is needed to provide them with a thorough education. That accounting curriculum is quite often merely a mirror of professional accounting syllabi, which mainly aim to test for skills that are relevant to professional work. That even when faculty members do conduct research, the products of such research do not find any place in the teaching curriculum.
- (v) The essence of research is discovery. Any research which does not lead to discovery adds very little to the existing body of knowledge. It is observed that accounting research makes little or no discovery because much of it consists of replicated works which do not add much to the existing stock of knowledge.
- (vi) Research is essentially theory based, especially scientific research which require the formulation of hypothesis either to confirm or disaffirm existing theory. However what accounting researchers mostly call theories are just pragmatic rules that

have developed or been distilled from practice over time.

- (vii) Accounting as a discipline lacks basic theory but rather works with dogmas which consist of rules prescribed by the accounting authorities and which bind practitioners who subscribe to such rules through their membership of a professional body.

It seems to me that before we can proceed with any meaningful analysis, we have first of all to contextualise the discussion. We should agree on what constitutes the scope of accounting research and what is accounting practice. Accounting research, as commonly understood, spans all the subject areas that make up accounting practice, namely, financial accounting and reporting, managerial accounting, audit and assurance, taxation, accounting information systems and of recent corporate governance. We do need to be clear in our minds which aspects of accounting we are referring to in this discussion. We know that the sub-areas do not necessarily all exhibit the same characteristics or function under the same constraints. For instance, while financial accounting and reporting is highly structured and very substantially influenced by laid down rules, managerial accounting on the other hand is not so. Audit and assurance is not very far from financial accounting in terms of the control exerted by the profession or a regulatory authority. Taxation on the other hand is strictly regulated by law, the relevant tax laws which apply in a country. Corporate governance is still a very fluid area which is not regulated and therefore very much thrives on voluntary compliance.

In my view, accounting practice should be construed to mean strictly financial accounting and reporting, audit and assurance, and taxation, but particularly, financial accounting and reporting.

In order to bring some order to this discussion, we should endeavour to compress the critical observations earlier mentioned into a fewer number by grouping related issues. We thus arrive at the following three main groups:

- (a) Issues arising from the difficulty in applying the scientific method to Accounting research.
- (b) The alleged weak link between accounting research output and accounting practice.
- (c) The nexus between accounting research and the training curriculum of accounting students.

Discussion

(a) Issues relating to the difficulty in applying the scientific method to accounting research.

As a reminder, the scientific method involves the formulation of a hypothesis which is based on theory; the hypothesis is then subjected to some data input and analysis, which may result in the hypothesis being confirmed or refuted. If confirmed then the result becomes part of theory. In the pure sciences a series of such confirmed theories will ultimately become a law. A law is a consistent pattern or process which is guaranteed to produce the same result. The focal point in the scientific process therefore is the existence of a theory. It presupposes the existence of a theory which guides the investigation. A popular definition of theory is the one given long ago by Kerlinger (1964) which says:

A theory is a set of interrelated constructs (concepts), definitions and propositions that present a systematic view of phenomena by specifying relations among variables; with the purpose of explaining and predicting the phenomena.

Emphasis should be placed in the above definition on the words "*explaining and predicting*". The relationships which the researcher confirms to exist through some proof must also to be capable of helping to predict future outcomes or, at the very least, being confirmed through replication by some other researcher. The strength of theory is its predictive value. Enabling one to be able to predict, after all, what justifies the effort of the researcher. In the absence of predictive value, the result cannot be worth much, even if his efforts result in marshalling a load of information.

The major problem which accountants confront here is that the relationships which they establish through proven hypothesis do not and cannot serve for purposes of predicting outcomes in all circumstances, because of the simple reason that accounting deals with human behaviour; it belongs to the behavioural sciences, and one of the innate characteristics of behaviour is variability, implying a limited possibility of prediction. Thus a relationship which exists in one situation cannot be guaranteed to exist in another. That is why it is believed that no universally accepted theory can emerge from accounting research. And this does not depend on whether we are dealing with pure normative theory (which is mainly prescriptive) or positive theory (which is descriptive), or a mixture or combination of

the two, which is sometimes referred to as the 'decision usefulness theory'. Decision-usefulness theory is actually an implicit admission of the limitations to the universality or generalisability of research findings; the fact that no consistent theory can exist in accounting.

Ryan et al (1992) have suggested that we have to be circumspect in what we call theory in accounting research because they tend to lack the ingredients of theory which include internal and external consistency. Ijiri (1975) long ago complained of the absence in accounting of a basic accounting theory, alleging that what we call theories in accounting are nothing but dogmas that have been distilled over time from practice. American Accounting Association in its publication 'Concepts and Standards for External Financial Reports argues that:

No single governing theory of financial accounting is rich enough to encompass the full range of user-environment specifications effectively; hence there exists in financial accounting literature not a theory of financial accounting, but a collection of theories which can be arrayed over the differences in user-environment specifications.

Belkaoui (1977) further nails the point when he avers that:

A single generally accepted accounting theory does not exist at this time. Several attempts have been made to formulate such a theory. Starting with different assumptions and using different methodologies, the various attempts have resulted in different frameworks for financial reporting standards.

The relative weakness in what accounting researchers call theory is made even more apparent in the definition of accounting theory given by Littleton and Zimmerman (1962) thus:

Accounting theory is primarily a concentrate *distilled from experience* it is experience intelligently analysed that produces logical explanation and illuminates the practices from which it springs.

I have emphasize the words '*distilled from experience*', because I believe that that is precisely what accounting theory is; it is distilled from experience. We all know that experiences vary because the phenomena that accounting measures as well as those who are involved in its preparation, and their various publics which they serve

are customarily loaded with subjectivity and prejudice.

That supports nails the point echoed by Inanga and Schneider that there is no really reliable theory in accounting. That what we call theories have very little consistency and therefore very limited capability of guiding prediction. They believe that it is one possible reason why accounting research findings fail to meet the requirements of accounting work. Practising accountants are primarily concerned with producing reliable and consistent reports which are aimed at a wide variety of users in their respective decision situations.

The apparent absence of a body of theory which is internally and externally consistent presents us accounting researchers with a confounding situation, especially as it is generally agreed that in the absence of theory, there can be no discovery, and therefore no new knowledge or addition to knowledge. We can probably refute this by claiming that there is obviously an increasing body of literature in the world (Nigeria not excluded) which confirm that accounting researchers are actively engaged in research. Pertinent questions which may be asked here are: what is the new knowledge is contained in these research papers being generated? How have this actually affected what accountants are doing?

In this respect some people try to contrast accounting with other professions where improvement in well-being or methodologies are noticeably traceable to research effort or findings. They cite for instance the case of the medical sciences, space sciences, engineering sciences, pharmaceutical sciences, etc. Some observers raise the question: in what way does accounting research influence or affect human well-being? The same question asked in another way: what improvement in well-being can one trace to accounting research findings? There is obviously a dilemma here which should challenge us accounting scholars and researchers. If there is any improvement at all, it is likely to be very minimal.

As a footnote to the above issue, a distinction is usually made between original research which results in new knowledge and a research that merely replicates or confirms an earlier work. Inanga and Schneider suggest that replicated or confirmatory researches are less valuable in that they do not add much to knowledge. They assert:

Research involving the replication of an experiment is generally valued much less than the original experiment, because the

outcome of such replication tends to add much less to knowledge than the original experiment.

b) The link between accounting research and accounting practice

The second issue is the proposition that there is no link between accounting research and accounting practice. That accounting researchers mostly investigate issues which are not of interest to accounting practitioners, and that because of this research findings do not find their way into what accountants do. Inanga & Schneider believe that it is not that accounting researchers are not conducting research, but that the issues which they research are of no interest to practising accountants. Further that there is a fundamental flaw in the accounting research process itself.

We have already disposed of the issue of the flaw in the accounting research process when we examined the difficulties faced by accounting researchers as a result of the relative absence of a consistent theory. It remains to consider what issues are actually being researched by accounting scholars.

To examine this empirically, I did a quick study of the articles published in the ICAN Journal of Accounting and Finance (IJAF) since its inception in 2009. There have been six issues to-date, featuring some 52 well researched papers. I appraised each of the articles to see which of them may actually be relevant to the work which practising accountants are engaged in. I found to my amazement that only a possible 15 out of the 52 (representing a paltry 29%) might be of marginal interest to practising accountants. I concede that I was actually very generous in assigning practical value to some these 15 articles. On the whole, much of the articles could possibly be said to generate information but whether such information would be of any value to accounting practice is very doubtful. Some of the more obvious cases showing possible disparity or divergence of interest include:

- (i) Network effects in African countries adoption of IFRS.
- (ii) Corporate attributes and financial disclosures: Bangladesh experience.
- (iii) The role of cooperative societies on standard of living in Ogun State, Nigeria.
- (iv) The short term effect of the global economic meltdown on the activities in the Nigerian Stock Exchange.
- (v) Quoted companies attributes and the reliability of financial reporting in Nigeria.

- (vi) Capital market: an engine for industrial growth and development.
- (vii) Ownership concentration and bank profitability: an empirical test of selected agency theories.
- (viii) An evaluation of the process, principles and formulae used in indirect revenue allocations in Oyo State LGS, Nigeria (2003 – 2007).
- (ix) Short term effect of the 2006 consolidation on the profitability of Nigerian banks.
- (x) Stakeholder perspectives and national perception of stakeholder governance.

In particular, in examining some of the published articles I found titles such as:

- (i) Disclosure practices and firm characteristics. (The firm characteristics measured were company size, profitability, liquidity, age of company, listing status, industry type, etc.)
- (ii) A test of the market efficiency of the Nigerian stock market.
- (iii) Factors that influence voluntary tax compliance (the factors considered were the level of efficiency of tax authorities, tax audit, level of tax education, taxpayers' perception of the level of judiciousness in the use of tax proceeds, penalty, etc.)

What I observed is that while all or most of these researches do generate information, perhaps information which may assist policy formulation in a broad range of areas of economics, finance and government, they do not relate whatsoever to accountants' basic concern to prepare and present credible financial reports. How to marry the interests of accounting researchers and those of practising accountants therefore constitutes a major concern.

c) The nexus between accounting research and the training curriculum of accounting students.

Accounting researchers are criticized for not incorporating the products of their research in their curriculum. The university curriculum is said to be predominantly oriented towards producing graduates who can be immediately useful to their employers upon graduation. Since the practitioner himself shows no interest in research findings, then the curriculum which is already quite loaded cannot accommodate any new developments in accounting knowledge as may be revealed from research.

I do not think that there is any of us here who will deny this fact. I have taken a sample of many university accounting curricula

and I have found to my surprise that they mostly mirror the professional examination syllabus. Professional examination syllabus has the principal aim to test skills, and is not so much concerned to inculcate or deepen the student's theoretical foundations. Some universities pride themselves over the fact that it takes their products only one or two years after graduation to pass the professional examination. Some even that some of their students complete their ICAN examinations before they graduate. This may be quite clearly an admission of the fact that their school curriculum has merely been preparing their students for the professional examination. The question then is: is that what university education really all about? Just to prepare students for professional examination? What has become of the old adage that the university is primarily a place for developing the student's mind and giving him a broad foundation that will enable him to adapt to whatever circumstances the future, which is customarily uncertain, may present? There is, to my mind, a fundamental confusion of roles and missions here!

Albrecht and Sach in their AAA sponsored publication titled *'Accounting education: charting the course through a perilous future'* lament that the university curriculum for the training of accountants is too practice-oriented, too problem specific and stereotyped; that it is excessively concerned with skill acquisition, whereas what students really need is a broad-based education in those disciplines that will enable them to adapt to situations which will certainly change by the time they leave school. Baxter (1988) had earlier argued that training accountants to apply set standards robs them of the necessary training in judgement and therefore denies them of resourcefulness and flexibility.

In a paper titled *'Changes in Education trends: How do we prepare the Accountant for the 21st Century'*, Anao (1998) argued that the type of training which accounting students need should emphasize more of developing and sharpening their reasoning faculty, and less of skill training. He advocates that in order to achieve this, the curriculum should be expanded to incorporate **more** courses is disciplines from which accounting draws. That is not to say that accounting courses should not be taught but they should be taught at all in a manner which explores the relationship between accounting and these other cognate courses rather than being loaded with competence in providing solutions to intricate and complex practical problems. Such a board based curriculum will equip the students

better to be able to tackle the wide-ranging situations which their after school life would of necessity present.

The supposition here is that a curriculum which strengthens the student's theory foundations, rather than one which focuses on technical skills, will be better amenable to adaptations to new developments arising from research. It is argued that if universities focused on strengthening the students theory foundations, the beneficiaries of such an educational system would be more likely to be research-friendly than if they had merely concentrated on skill training in their undergraduate years.

To conclude this part, it is evident that we do have enough evidence to support the view that accounting researches make very little, if any contribution towards the development of accounting practice. That accounting research has not much impacted accounting practice. We argue that this situation will not much assist or enhance the growth of accounting as a discipline and a profession.

What is the way out?

The way out is obviously to marry the interests of both accounting researchers and practising accountants, but how do we do this? We face some dilemmas here. We can for a start demand that accounting researchers should find a way to make their efforts more relevant to the requirements of practice; that they should focus their researches on those issues that are of concern to practising accountants, assuming that there is a way for them to ascertain what those issues are. The major problem here is that practice is mostly characterized by compliance with prescribed rules. Rules are by nature imposed by law or standard setting bodies who do not necessarily subject them before hand to any scientific analysis. Standards stand on the footstool of normative theory, which is said to be relatively unscientific. In contrast to prescriptive theory which is said to be better adapted to the scientific process. The implication is that if researchers align themselves to the requirements of standard setting, they might not be able to produce scientific papers which would be acceptable to the academic community for advancement purposes.

That is dilemma number one.

A second dilemma arises from the fact that if practitioners decide to open their work to admit the findings of scientific investigations (thus aligning positive theory), then they would end up admitting into practice methods which violate standards. Horngren has pointed out that standard setting follows a negotiated process, so that in the end it is not the best method that is adopted but one which meets with the convenience and acceptance of the a cross-section of preparers and users. Solomons (1983) agrees with this view; he also believes that standard setting is a political process. If standard setting is a negotiated or political process, then it cannot be significantly affected by the results of scientific investigation.

Dilemma number two.

The third dilemma arises from the challenge which universities would face if they had to depart from the present skill-laden training processes and opt for a broader based educational system. This may run counter to the interests of employers who demand graduates that can be immediately useful. The better educated broader-based students would, of necessity, entail further investments on training by their employers and this might prove economically unacceptable. In the end, universities may lose the support or recognition of industry if they fail to produce what industry desires.

Dilemma number three.

How do we resolve these dilemmas?

We must begin by first admitting that there is absolutely no alternative to bridging the divide in the interests of both accounting researchers and practitioners, if the discipline and profession of accounting or accountancy is to grow. Research offers the only route for advancement in knowledge. Therefore accounting practitioners must find a way not only to accommodate the products of research but even sponsor research. A professional institute such as ICAN must recognise the need to take a lead in this. There is evidence that ICAN is already doing much in this regard. In spite of such efforts, there is still a hiatus, which must be filled. Sponsoring this conference is one positive step. Publishing an academic journal is another. The problem is: what happens to the findings of the research papers which will be presented at this conference? We are told that the better ones among these will be

published in the Institute's academic journal. After that, what next? If our actions simply end there, we will just be confirming the view that accounting researches do not improve accounting practice. It is remarkably appropriate that the theme of this conference is: BLENDING ACCOUNTING THEORY WITH PRACTICE. But, will our efforts here actually contribute anything towards bridging the existing divide?

I admit that the Mandatory Professional Education scheme partly aims at bridging this divide, but to the extent that the scheme is only haphazardly followed and hardly ever enforced, positive results can never be achieved. Secondly, a very painstaking effort has to be made in designing MPE schemes, an effort which will harnesses the best brains in the profession (in practice and industry) on the one hand and seasoned academics from the universities) on the other, if the MPE scheme is to be properly focused.

Inanga and Schneider have proposed a model which relates accounting research, accounting education, professional training and accounting practice, in a horizontal linear fashion, with support from MCPE post qualification. I have no quarrel with this model. What it stops short at, however, is how the various functions are to be allocated among the various actors – university/university teachers, industry (training firms), and the professional institute.

Given that there is at present a major deficiency in the manner in which the education and training functions are at present shared, I have always advocated that there should be some element of specialisation in the process; that universities should concentrate more on providing a strong theoretical foundation, and leave the training in practical skills to professional firms and industry. That way the present system whereby education and training activities are collapsed into one, much of which is undertaken within the university system denies the student of the opportunity of obtaining a strong theory foundation, which is essential for the growth of the discipline.

Universities must recognise that devoting so much effort to skill development constitutes a basic misunderstanding of the purpose of a university. The university is basically a place for developing the individual's mind; skill training should be of secondary interest. Skill training is best done in the actual work situation. Universities should therefore concentrate on strengthening the student's intellectual capacity by emphasizing theory, leaving the profession to test for proficiency and skill which the student will acquire in the

practical field after his school days. The separation between the two functions is well recognised in some professions such as Medicine, Law and Engineering. In Medicine the student first obtains his basic degree in the health sciences before going to develop clinical skills in a hospital. The would-be lawyer goes to Law School to hone his professional law skills after his university Law degree. The would-be engineer serves his articles under supervision by a qualified practising engineer before obtaining his own COREN registration.

In some advanced countries the professions of Law and Medicine even require that aspirants should obtain first degrees in some other discipline before they can register for a Law or Medical degree in the university. In the USA, a student must first obtain a degree in a cognate subject (which need not be Accounting), before going on to prepare for the CPA examination. Accounting programmes of most USA universities do not mirror so closely the CPA syllabus, as our own universities do. It is perhaps for this reason that accounting research is most vibrant in the US.

We advocate here that if accounting departments of Nigerian universities would henceforth concentrate on giving their students substantial depth in theory, they would have given their products a sound foundation which would enable them to better appreciate the relevance of research to the profession. An accountant who is well grounded in theory who later goes on to become a professional accountant will be more likely to engage or blend more easily with accounting research findings.

Our University researchers can also do more to incorporate or integrate research findings in their curriculum. More fundamentally they should completely review their curriculum for the education of the future accountant. The undergraduate programme should be more theory based and comprise less of skill training. The present system, unless reoriented, will likely continue to produce accountants who lack the requisite theoretical orientation which is for the development of the accounting discipline.

Conclusion

To conclude this address, let us revert to the question which we posed as the title of this discourse, namely, ***what is the purpose of accounting research – to improve accounting practice or merely to enrich accounting literature?*** Based on the arguments adduced in the foregoing, we should have no difficulty in agreeing that accounting researches at present mainly enrich the

literature and that they have little impact on accounting practice. There is certainly no strong evidence that all the literature being generated by researchers are making any meaningful impact on accounting practice. Accounting researchers and accountants in the field do seem to live in their separate worlds, with very little interaction, if any, between them. That being the case there is a pressing need to change the situation. Doing this requires efforts by all parties – the profession, accounting researchers, as well as the regulatory authorities. At this forum it is appropriate to suggest that the Institute of Chartered Accountants should set up a Committee to take an incisive look at this problem, at least with reference to Nigeria, and to come up with some suggestions as to how to bridge the difference between accounting research and accounting practice. Such a committee must have capable representations from each side of the divide.

References

Albrecht, W.S. & Sach, R. J (2000). *Accounting education: charting the course through a perilous future*, American Accounting Association.

Anao, A R. (1998). Changes in education trends: How do we prepare the Accountant for the 21st century?, in Osisioma, B C & Okoye, A. E (eds), *Problems and Prospects of Accountancy Profession in the Next Millennium*, Nigerian Accounting Association.

Baxter, W.T. (1988). *Accounting research-academic trends versus practical needs*. The Institute of Chartered Accountants of Scotland.

Carsberg, B. V (1997). Foreword. In Cooke, T. & Nobes (eds) *The festschrift in honour of R H Parker*. London: Routledge.

Demski, J S (2001). Some thoughts on accounting scholarship. Presidential address on the forum of AAA.

Ijiri, Y (1975). *Theory of Measurement*. American Accounting Association.

Inanga, E. L & Schneider, W. B. (2005). The failure of accounting research to improve accounting practice: a problem of theory and lack of communication, *Critical Perspectives on Accounting*.

Kerlinger, F. N (1964). *Foundation of Behavioural Research*, New York: Holt, Rinehard & Winston. Riahi-Belkaoui A (2014). *Accounting Theory*, London & New York, The Dryden Press.

Ryan, B, & Scapens, R. W, Theobald M, (1992). *Research method and methodology in finance and accounting*. London: Academy Press Limited.

Solomons, D (1983). The Political implications of accounting and accounting standard setting. *Accounting and Business*.

Sterling, R. R. (1973). *Accounting research, education and practice*.

Watts, R. L & Zimmerman, J L (1986). *Positive Accounting Theory*, Prentice-Hall International.

PAPERS PRESENTED AT THE CONFERENCE

The papers presented at the maiden Academic Conference of Accounting and Finance organized by the Institute of Chartered Accountants of Nigeria (ICAN) were categorized by subject matter.

ACCOUNTING EDUCATION

EFFECT OF TEACHING METHODS ON THE PERFORMANCE OF ACCOUNTING STUDENTS' IN BENSON IDAHOSA UNIVERSITY IN NIGERIA:

OBASI Rosemary O., URHOGHIDE Ruth O., & ARCHIBONG Comfort

ABSTRACT

This study examined the effects of teaching methods on accounting students BIU. The main objective of the study is to examine if teaching methods affect students' performance. Also to determine the teaching method or methods that will yield the best result, and to ascertain whether students' opinions differ across levels, sex and age. The researchers used the stratified random sampling technique. Students were stratified by level and by performance in financial accounting course. Three students were randomly selected from each grade i.e. A B C D E F from 200, 300, and 400 levels. The researchers conducted a quasi experimental study, where fifty-four students (54), eighteen each from 200,300 and 400 levels formed the sample size. These 54 students passed through the tutelage of four different lecturers representing the four methods at different times for four weeks. After the lectures' periods, each lecturer examined the students and graded them. Then the researchers distributed questionnaires which enabled the study achieve its objectives. The data analyzed showed that the students had hundred percent (100%) believe that teaching method affects performance, that there is need for the use of different teaching methods for different courses and that, demographics should not influence the choice of method. The conclusion was that age and gender do not influence the students' performance for different methods used. The study recommends that NUC and ICAN should include in their accreditation requirements that lecturers report their teaching method(s) in each course score sheet. The essence of this is that, on the long run, performance and teaching methods can be studied using secondary data which in this case, will generate a more reliable result.

KEY WORDS: Teaching Strategy, Teaching Methods, Effective Learning, Students' Performance,

INTRODUCTION

Having knowledgeable students is the core goal of all universities. To achieve this goal, lecturers with their different teaching methods play an important role. The objective of this research work is to ascertain

the effects of teaching methods on students' level of performance. Each student learns best when the teaching method or style that suits his or her needs is used. The method that suits students learning enables them to be successful at school. While there are some students that are very successful at school, there are a few who do not experience success in school. This set of students has been anecdotally shown to have improved after teaching them using the method that works for them.

Research evidence shows that the challenges confronting the lecturers are basically on the methods of imparting the knowledge. It was argued by Adufe (2008) as cited in Omotere (2011:5) that teaching is based on methods which on the long run bring about effective teaching. According to Aladipo and Ajeni (2000) as cited in Omotere, (2011:5) teaching involves bringing about or at least facilitating desirable changes in learners. Cook & Hazelwood (2002) define teaching as the transmission to the learner and the acquisition by him or her of specific skills, information, knowledge or other established data. The mode of teaching applied in achieving these objectives is referred to as method or strategy. Methodology therefore refers to the processes and techniques a lecturer uses to transmit facts, skills, information and knowledge to students so as to achieve the set objectives.

Based on the foregoing, the researchers sought to ascertain whether teaching methods affect students' performance and if it does, to find whether there is difference between students' opinions across their levels, sex, and age on teaching methods. The study also sought if students perceive teaching methods as a tool for enhancing the level of performance. To achieve these objectives, the researchers tested the following hypothesis:

There is no significant difference in the level of performance of students across their levels, age and gender.

The result of this study shall be of immense value to lecturers who desire to impact students. The universities will find the result interesting as it enables the institutions achieve their primary objective. Regulators, international educational bodies etc will benefit from the result of this study, since it shall bring to the fore the need for teaching methods and how it impacts students' level of performance.

This paper is subdivided into five sections. The first is on the background to the study. The second outlines the various related

literature reviewed. The third delineates the methods and materials adopted. The fourth analyzes the data generated from the experiment and discusses the results. The last section outlines the recommendations and conclusions of the study.

REVIEW OF RELATED LITERATURE

Research evidence shows that the major problem in higher institutions is the method of imparting knowledge (AICPA, 2004). This is also confirmed by the study carried out by Bonk & Smith (1998) which reveals that the methods presently employed in teaching in most of our universities are inadequate or not effective. It is of a necessity that a skillful lecturer needs to be conversant with various teaching strategies which may be applied to courses at different class situations. Omotere (2011) affirms that many methods of teaching exist in education and these methods are meant to make lecturers succeed in their bid to disseminate knowledge. Also, the impact of any teaching method is not only limited to the condition surrounding the teaching but also the advantages and disadvantages of a particular method in a particular situation should not be overlooked.

Lynch (2001, p.177) reports In order to promote deep rather than surface learning in their students the member of staff must endeavour to motivate and provide various stimulating teaching strategies. Lecturers often do not link their teaching to students' achievements, but attribute outcomes to factors beyond their control, such as students' background. However, researchers report that teacher/classroom effects can account for up to 60 per cent of the variance in student achievement. Lecturers need to understand their own practice and how it affects student achievement. They need an understanding of the developmental nature of the construct areas in which they teach, and this must precede or underpin their understanding of the developmental assessment.

Performance and teaching methods

McWhorter & Hudson-Ross (1996) found that without new approaches to instruction that connect to the learning needs of students, many will perform poorly and are likely to drop out of studies. Adunola (2011) indicated that in order to bring desirable changes in students, teaching methods used by educators should be best for the subject matter. Furthermore, most researchers sustained that teaching methods work effectively mainly if they suit learners'

needs since every learner interprets and responds to questions in a unique way. As such, alignment of teaching methods with students' needs and preferred learning influence students' academic attainments (Ganyaupfu, 2013). Hence, bias in selection of teaching methods by teachers in areas in which they possess exclusive monopoly knowledge should be avoided to improve students' academic performance (Adunola, 2011). Thus, this sort to ascertain some of these factors that can help a teacher understand the method or methods that might be suitable for a student.

i. Lecture and Class Discussion (Known as Teamwork 1)

This method is a situation whereby a lecturer discloses a topic to the students but allows the students discuss the topic to the best of their knowledge before he or she then lectures the students on the topic. During the discussions, the students interact with one another, express themselves freely, whether right or wrong etc after which the lecturer then teach the topic to clarify issues. It is a form of team work, because the students can corroborate their ideas. Duff (2004) conducted a case study on several teaching strategies in Accounting. The researcher explores the reasons for their use, and perceptions of effectiveness. The study's suggested that various strategies do influence teaching effectiveness. This led to further studies on teaching methods in the area of accounting. Recently, more research in accounting studies have suggested that teaching strategies that involve team work have a positive effect on student performance. For example, a study conducted by Johnstone and Biggs (1998) suggested that students prefer student group study for better learning in the class. Lynch (2001) acknowledged the positive impact of social interaction in groups. Norman, Rose & Lehmann (2004) stated that team work had better potential compared to other teaching strategies. Also see these researches which report that team work has good potential for increasing students performance (Ahles and Contento, (2006); Bennett, Hogarth, Lubben, Campbell, and Robinson, (2010); Schul, (2011); Sharan, (2010); Yu-Fen and Kai-Wen (2009); Nagel (2008) etc). Team work allows students to work well together for specific tasks. The core point of team work is the positive interdependence-learning atmosphere created as the students work in a group.

ii. Lecture and assignments (Also known as team work 2)

Lecture and assignment is another type of team work where after lectures, students are given assignments which they are expected to

discuss with their follow students and lecturers where necessary. This is to enable the student have a broad understanding of the topic and to encourage group discussions. It is also referred to as reinforcement of teaching which is essential to the total leaning experience (Ani, 2003). This method has not been examined by previous researchers to the best of the researchers' knowledge. However, it is a recognized method adopted by most lecturers thus; this study intends to examine its influence on students' performance.

iii. Lecture and Class Work

Lecture and class work simply means a lecturer teaches a topic, afterwards, he/she examines the students to ascertain their level of understanding of the topic taught. The lecturer takes the pain to have one on one assessment of what the students did and where necessary correct them on the spot. Okon (2001) reports Ani (2003) that "one useful correction given on the spot can be more valuable than a dozen 'red marks' in the students note book" (p 270). Campbell & Mayer (2009) report support for team work and class work as a teaching method that is vast. But few studies have discussed the comparative effect on students' academic performance of these two teaching methods. One study that comes very close to this found that the mean scores of the team work group were slightly higher than the Class work (Hosal-Akman and Simga-Mugan, 2010). Another study showed that teaching methods did have a significant effect on students' scores on achievement test (Sadi and Cakiroglu, 2011). Several studies showed that students' perception have a relationship with teaching strategies and academic performance. Their study also found that the method used seemed to affect students' perception toward the class, and this may be the factor that most influences learning.

iv. Flipping in and Out of Lecture/ Technology and Lecture

Flipping in and out of lecture can also be referred to as technology and lecture. This method, allows the students to use their laptops or handsets to browse a question or topic to enhance their knowledge and they then discuss their findings in class, after the discussions the lecturer then lecturers to emphasize the key issues. It is general knowledge that when students have a positive perception of something, they will do the task well. Technology via the internet is a cherished modernity of the youth and there is this thinking that if students are encouraged to employ this aspect into learning, there is the likelihood of it improving their performance. A study by Akkuzu

and Akcay (2011) showed a relationship between students' perception and their academic performance. They suggested that students' positive attraction toward certain kinds of teaching may help increase their academic performance. Hence, we raised the question: does the use of technology (browsing to source for answers in class) impact positively on students' performance?

Theoretical Framework

This study is driven by the Theory of Performance known as 'TOP' propounded by Elger, (undated). However, the researchers do not intend to validate the theory but used it to direct the methodological design of the study. Developing performance is a journey, and *level of performance* describes location in the journey. Current level of performance depends holistically on 6 components: context, level of knowledge, levels of skills, level of identity, personal factors, and fixed factors. Three axioms are proposed for effective performance improvements. Conditions for optimal performance and improvements in performance can be synthesized in three axioms: **Axiom 1**—engage the performer in an optimal emotional state (*performer's mindset*). **Axiom 2**—*immerse* the performer in an enriching environment. **Axiom 3**—engage the performer in *reflective practice*.

- a) **Performer's Mindset.** Performer's mindset includes actions that engage positive emotions. Examples include setting challenging goals, allowing failure as a natural part of attaining high performance, and providing conditions in which the performer feels a right amount of safety. This axiom guided this study to include all categories of students' grades in the study.
- b) **Immersion.** Immersion in a physical, social, and intellectual environment can elevate performance and stimulate personal as well as professional development. Elements include social interactions, disciplinary knowledge, active learning, emotions (both positive and negative), and spiritual alignment. We deduced that for immersion to take place we have to directly involve the students in a unique environment of learning.
- c) **Reflective Practice.** Reflective practice involves actions that help people pay attention to and learn from experiences. Examples include observing the present level of performance, noting accomplishments, analyzing strengths and areas for

improvements, analyzing and develop identity, and improving levels of knowledge. This enabled the researchers to work with the previous result of the student as their pre-test indicator.

Conceptual Framework

The study focused on a target population from which a sample size was extracted using the pre test scores. These students then passed through some tutelage and test which is referred to as the intervention (ie X_1, X_2, X_3, X_4 representing the different teaching methods) and the same data were collected after the intervention took place (post-test). This study design only looks at one group of individuals who received the intervention, which is called the treatment group. The pre-post test design allows you to make inferences on the effect of your intervention by looking at the difference in the pre-test and post-test results.

Figure 1: Study's model

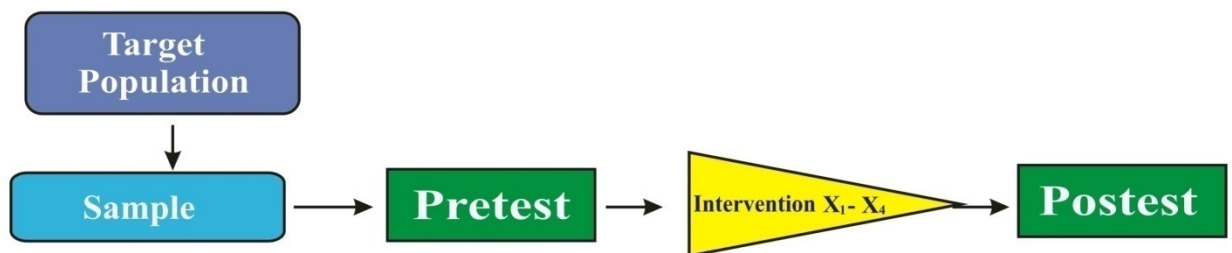

Developed by Obasi, R. (2015)

METHODS AND MATERIALS

The researchers adopted quasi-experimental research design. A **quasi-experiment** is an empirical study used to estimate the causal impact of an intervention on its target population (Campbell, 1988). Quasi-experimental research design provides the best results for the cause and effect relationship of the experimental and comparison group. Quasi-experiments are commonly used in social sciences, public health, education, and policy analysis, especially when it is not practical or reasonable to randomize study participants to the treatment condition (DeRue, 2012). Quasi-experiments are also effective because they use the "pre-post testing". This means that there are tests done before any data is collected to see if any person confounds or if any participants have certain tendencies. Then the actual experiment is done with post test results recorded. This data

can be compared as part of the study or the pre-test data can be included in an explanation for the actual experimental data. Quasi experiments have independent variables that already exist such as age, gender, level etc. These variables can either be continuous (age) or they can be categorical (gender). In short, naturally occurring variables are measured within quasi experiments (Morgan, 2000).

The population is 198 drawn from 200, 300, and 400 level students of accounting in BIU in 2013/2014 session. The total number is 198 students. The sampling method adopted was stratified random sampling. To achieve this, students in each level were categorized by performance ranging from A to F in accordance with the university grading system. From each category, three students were randomly selected making a total of fifty-four (54) students.

However, the sample size is small (27%) in relation with the population. This can be explained by various factors. Firstly, being individuals' study, to gather students for the study was not easy. Secondly, for this sort of study, participants were motivated and this was expensive and finally, the experiments were done during the evening periods, most students were tired and not willing to spare their time.

Table I: Study's Sample Size

Level	Number of Students		
	Male	Female	Total
200	9	9	18
300	6	12	18
400	12	6	18
TOTAL			54 Students

The 54 students were taught by four different lecturers each using a selected method. After four weeks, the students were examined by each of the lecturers. The scripts were marked and graded. Also, the researchers distributed questionnaire to the students which enables the research objectives to be achieved.

Table II: Variables Scaling and Measurement

Variables	Scale	Measureme
AGE		
	16-20 YEARS	1
	21-25 YEARS	2
SEX		
	MALE	1
	FEMALE	2
LEVEL		
	200	2
	300	3
	400	4
METHODS		
A	Lecture and Class work	1
B	Lecture & Assignment	2
C	Lecture & Class discussion	3
D	Introducing Technology into	4
POSSIBLE COMBINATIONS		
A&B	combinations	5
A&C	combinations	6
A&D	combinations	7
A, B, & C	combinations	8
A, B, & D	combinations	9
A,B,C,& D	combinations	10
B&C	combinations	11
B&D	combinations	12
B,C&D	combinations	13
C&D	combinations	14

The E- Views software was employed for the analysis of this study. The use of simple percentages, descriptive statistics as well as the use of the t-test statistics to test the hypotheses was employed.

Description of the T -test Statistics

The t-test is a parametric statistical tool that can be adopted to test the significance between the means' differences based on the student t-distribution given that the sample is normally distributed. The following t-test formula was adopted;

(1) One sample mean t-test

$$T = \frac{\bar{x} - \mu}{s / \sqrt{k - 1}}$$

Where;

T = t-calc

x = mean score of each question items

μ = the expected mean = 2 ie lecture
 and assignment
 S = the sample's standard deviation
 n = number of respondents

$K - 1$ = the degree of freedom

(2) Two sample mean t-test =

$$T = \frac{\bar{x}_2 - \bar{x}_1}{\sqrt{\frac{S_1^2 + S_2^2}{N_1 + N_2}}}$$

Where;

\bar{X}_2 = mean score for group2

X_1 = mean score for group1

S_1 and S_2 = standard deviation of each group

N_1 and N_2 = no. of respondents in each group

α = 5% level of significance

$(K - 2)$ and $(n_1 - n_2 - 2)$ are the degrees of freedom, the one-tailed t distribution's critical value is 1.645.

Decision rule:

The decision rule is to reject the H_0 and accept the H_1 if the calculated t is greater than the t-value from the table; otherwise accept the H_0 and reject the H_1 .

DATA ANALYSIS AND DISCUSSION OF RESULTS

We conducted an experimental study where we had fifty-four students (54), eighteen (18) each from 200, 300 and 400 levels. These 54 students passed through the tutelage of four different lecturers representing the four methods at different times. After four weeks of tutelage, each lecturer examined the students and graded them. After the entire classes, the researchers distributed questionnaire which enables the study achieves its objectives. Below is the presentation of personal data of students in table III.

Table III Summary of Students' Personal Data

Variables	Scale	Frequencies	Percentage
Age	16 -20 years	30	56
	21- 25years	24	44
Gender	Male	27	50
	Female	27	50

Frequencies

Level		Male (%)	Female (%)	16-20 Years	21-25 Years
		200	9(33)	9 (33)	15 (50)
300	6(22)	12(44)	12 (40)	6 (25)	
400	12(44)	6 (22)	3 (10)	15	
Total	27 (100)	27	30	24	

Source: Field Work, (2015)

From the above table, the summary shows that, 33 percent represent both male and female students in 200 level. In 300 level, 22 and 44 percent represent male and female respectively while, 44 and 22 percent of the students were male and female respectively representing 400 level students. With regard to the age of students, the result shows that, 50,40, and 10 percent represent students within the ages of 16 to 20 years across the different levels while, 13, 25, and 63 percent approximately represent the ages of students within the ages of 21-25 years. The result of the students' performance from each lecturer is shown below.

Data Analysis and discussion of results

In analyzing the data collected, we used the descriptive statistics. To achieve this, we analyzed the results of one randomly selected student each from each category of students' grades. Summary of this is shown below in table IV.

Table IV Pre and Post Students Scores and Grade from the Different Methods

Students	Initial Grade (PRE)	Level	Methods			
			A (Lecture and Class work)	B (Lecture & Assign)	C (Lecture & Class Discussio	D (Introducing Technology into Lectures)
			POST INTERVENTION			
			Scores (Grade)	Scores (Grade)	Scores (Grade)	Scores (Grade)
1	A	200	70 (A)	100 (A)	95 (A)	80 (A)
2	B		50 (C)	70 (A)	90 (A)	60 (B)
3	C		70 (A)	80 (A)	50 (C)	60 (B)
4	D		100 (A)	100 (A)	90 (A)	70 (A)
5	E		45 (D)	80 (A)	55 (C)	80 (A)
6	F		40	80 (A)	15 (E)	70 (A)

1	A	300	100 (A)	100 (A)	100 (A)	60 (B)
2	B		100 (A)	100 (A)	90 (A)	70 (A)
3	C		100 (A)	100 (A)	80 (A)	60 (B)
4	D		0 (F)	100 (A)	60 (B)	50 (C)
5	E		80 (A)	20 (F)	70 (A)	55 (C)
6	F		20 (F)	50 (C)	80 (A)	25 (F)
1	A	400	100 (A)	80 (A)	100 (A)	80 (A)
2	B		90 (A)	100 (A)	80 (A)	80 (A)
3	C		80 (A)	80 (A)	75 (A)	60 (B)
4	D		100 (A)	100 (A)	60 (B)	70 (A)
5	E		100 (A)	80 (A)	90 (A)	80 (A)
6	F		60 (B)	10 (F)	50 (C)	15 (F)

Source: Experimental Result (2015)

From the result above, 200 level students' performances improved such that only one student failed (i.e. had F grade) in method C (i.e. lecture and discussions) but 300 level students had very high grades. However, four students failed under three methods (i.e lecture and classwork, lecture and assignment and technology respectively) while, 400 level students scored very high and two students failed in two methods (i.e lecture and assignment and technology). We also observe that, the poorest students in 200 level made his/her best under method B (lecture and assignment). This seems to show that, students in 200 level enjoy team work where they can discuss with others to understand lectures better. The poorest in 300 level, failed in two methods (ie methods A & D) but had his /her best in method C. This group also shows that they support team work for better understanding as well as, appreciates group discussions. We also observe that, he/she had his/her second best in method B which is also a result of team work. For the final year students, the poorest student failed in two methods (B & D, i.e assignment and technology). His / her best was in method A (ie lecture and classwork) followed by method C (lecture and discussions). This shows that, as the students mature into the university system, they become more independent. They enjoy class work and class discussions.

The data collected also show that the students had hundred percent (100%) perception that teaching method is a tool for effective learning and that there is need for the use of different teaching methods for different courses. We used the simple average and mode to ascertain which of the method/(s) is/are best for the students. Table VI below shows the observations.

Table V Summary of students' opinions and experiment's result on the best method/(s)

		Mean	Mode	Scale
Method	Existing	44	-	
A	Lecture	& 73	100	
B	Lecture	& 79	100	
C	Lecture	& 74	90	
D	Technology and	63	60	
Level	200	9	11	9=AB&D ; 11= B & C
	300	8	-	8=AB&C
	400	10	14	10=ABC&D ; 14 =
Age	16 -20 Years	5	2	5 =A&B ; 2=B
	21-25 Years	4	3	4 = D; 3 = C
Gender	Male	4	6 &14	4=D; 6=A&C & 14=C
	Female	5	12	5 =A&B; 12=B&D

Source: Analysis result 2015

From table V above, method B had the highest mean (ie 79%) with most of the students scoring 100% while, the least was D with an average of 63% and mode of 60%.

For the levels (ie 200, 300 and 400 levels) the best method(s); AB&D, AB&C and ABC & D respectively represent the averages of the different levels best method/ (s) while the modes are B& C and C&D for 200 and 400 levels respectively while 300 level students cut across the methods.

As for age and best method, those below 20 years averagely went for A&B methods while, the mode was B but for those above 20 years went for method D on the average and most of them scored their best in method C.

Finally, the male students on the average went for method D with most of them scoring more using methods A&C as the best method/(s) while, the female students on the average chose methods A&B with their mode being methods B&D. Based on the foregoing, it seems that level influences choice of methods, age and gender do not influence the choice of method to be adopted by lecturers.

Test of Hypotheses

To test the hypotheses of this study, we employed the student t-test statistics, for the test of difference between the levels. As for age and gender, we used the paired t- test because; they were measured in two groups.

Hypotheses

H_0 : There is no difference between students' opinions on best teaching method/(s) and their levels.

H_0 : There is no difference between students' opinions on best teaching method/(s) and their age.

H_0 : There is no difference between students' opinions on best teaching method/(s) and their gender.

Table VI Equality Test Result on Best Method

		n	Mea n	Std Dev.	Tcal	Critical value	Sig. (2-tailed)
Hypothesis one	Level						
	200	18	10	5.811	3.3	2.571	0.021
	300		8	2.317	6.1	2.571	0.002
	400		9	3.834	4.1	2.571	0.009
Hypothesis two					53		
	Age						
	16-20	54	5	5.018	0.2	2.11	0.833
	21-25		4	5.628			
Hypothesis three	Gend						
	Male	54	4	5.082	-	2.11	0.588
	Female		5	5.504			

Source: Analysis Result (2015)

From the above table, the result shows that all the t_{calc} are greater than critical value for level variable. Therefore, we reject the null hypothesis of equality and this is significant across the levels at 5%. This indicates that, the students can identify from their perception the best teaching method/(s) to ensure effective results of students' performance. This decision is reached because we compared the

students average actual performance to their average perceived best method and from the above decision, there is significant difference (i.e. 0.021, 0.002 & 0.009) for 200, 300, and 400 levels respectively. As for the variable age, the result shows that t_{calc} is less than critical value hence; we fail to reject the null hypothesis that there is no difference between the perceptions of the students across the different ages but this decision is not significant statistically. Also, the t_{calc} for gender is greater than the t critical value. As a result, the decision is that we fail to reject the null hypothesis of equality amongst gender. Therefore, gender and age are not factors to consider when determining best teaching methods.

Summary of results

In summary, the results of this study have shown the following:

- Students had 100% perception that teaching method is a tool that can enhance performance and that there is need for the use of different teaching method(s) for different courses.
- Teaching method(s) that best yield effective result as shown in Table IV shows that students in 300 and 400 level enjoy methods B and C while students in 200 Level enjoys methods A and B. This result is consistent with the findings of a lot of researchers who found team work or collaborative teaching to have positive impact on students performance [see, Ahles and Contento, (2006); Bennett, Hogarth, Lubben, Campbell, and Robinson, (2010); Schul, (2011); Lynch, (2001); Norman, Rose, & Lehmann, (2004)]
- The Level a student is influences the teaching method that impacts the students' level of performance.
- Age and gender do not influence the choice of teaching method that should impact the students' level of performance.

CONCLUSION AND RECOMMENDATIONS

We examined the effect of teaching methods on accounting students' level of performance. Findings suggest that students had hundred percent (100%) perception that teaching method is a tool for performance improvement and that there is need for the use of different teaching methods for different courses. The Level a student is, determines the teaching method that impacts his/her performance while, age and gender do not influence the choice of teach method by the students. Based on the findings of this study, the following are some measures recommended by the researchers:

- Age and gender should not be considered when considering the teaching methods because, based on the findings from table V above, age and gender do not influence the performance of students using different teaching methods.
- Lecturers, universities' management, ICAN and Nigerian Universities Commission should recognize that teaching methods enhance students' academic performance; and
- Lecturers must consider the most effective method to apply in teaching different levels.

POLICY IMPLICATIONS

The policy implication of this study will affect the following accrediting bodies:

- **NUC:** We recommend that NUC includes in its requirements that lecturers report their teaching method(s) in each course score sheet.
- **ICAN:** ICAN is passionate about the quality of graduates from different universities hence; it accredits the accounting departments of interested institutions. We therefore, recommend that ICAN includes the same as part of its accreditation requirements.

The essence of this is that, on the long run, performance and teaching methods can be studied using secondary data which in this case, will generate a better result.

REFERENCES

- Adunola, O. (2011). *The Impact of Teachers' Teaching Methods on the Academic Performance of Primary School Pupils in Ijebu-Ode Local cut Area of Ogun State*. Ego Booster Books, Ogun State, Nigeria.
- Ahles, P. M., & Contento, J. M. (2006). Explaining helping behavior in a cooperative learning classroom setting using attribution theory. *Community College Journal of Research & Practice*, 30(8), 609-626.
- AICPA, (2004). Sample teaching strategies and classroom techniques that address the core competencies. Available at <http://www.aicpa.org/edu/teachstrat.htm>

- Akkuzu, N., & Akcay, H. (2011). An effective model to increase student attitude and achievement: Narrative including analogies. *US-China Education Review, A5*, 612-623.
- Ani, B. (2003). Issues and insights into learning concepts as applied to book keeping. Unpublished material, 268-272
- Bennett, J., Hogarth, S., Lubben, F., Campbell, B., & Robinson, A. (2010). Talking science: The research evidence on the use of small group discussions in science teaching. *International Journal of Science Education, 32*(1), 69-95.
- Bonk, C.J. & Smith, G.S. (1998). Alternative instructional strategies for creative and critical thinking in the accounting curriculum. *Journal of Accounting Education, 16*(2), 261-293.
- Campbell, D. T. (1988). *Methodology and epistemology for social science: selected papers*. University of Chicago Press. ISBN 0-226-09248-8.
- Campbell, J., & Mayer, R. E. (2009). Questioning as an instructional method: Does it affect learning from lectures? *Applied Cognitive Psychology, 23*(6), 747-759.
- Cook, E.D. & Hazelwood, A.C. (2002). An active learning strategy for the classroom-"who wants to win ... some mini chips ahoy?" *Journal of Accounting Education, 20*(4), 297-306.
- DeRue, Scott (2012). A Quasi Experimental Study of After-Event Reviews. *Journal of Applied Psychology 97* (5): 681–689. doi:10.1037/a0028244
- Elger, D. (undated). Theory of performance. Available at http://www.pcrest2.com/fol/1_2_1.htm
- Duff, A. (2004). The role of cognitive learning styles in accounting education: Developing learning competencies. *Journal of Accounting Education, 22*(1), 29-52.
- Guayaupfu, E.M. (2013). Teaching methods and students' academic performance. *International Journal of Humanities and Social Science Invention 2* (9).29-35
- Hosal-Akman, N., & Simga-Mugan, C. (2010). An assessment of the effects of teaching methods on academic performance of

- students in accounting courses. *Innovations in Education and Teaching International*, 47(3), 251-260.
- Johnstone, K.M. & Biggs, S.F. (1998). Problem-based learning: introduction, analysis, and accounting curricula implications. *Journal of Accounting Education*, 16(3-4), 407-427.
- Kagan, S. (1990). The structural approach to cooperative learning. *Educational Leadership*, 47(4), 12-15.
- Lynch, B. (2001). Innovative Teaching in a Higher Education Establishment - how extraordinary? *Journal of Further and Higher Education*, 25(2), 176-194.
- Morgan, G. A. (2000). *Quasi-Experimental Designs*. *Journal of the American Academy of Child & Adolescent Psychiatry* 39 (6). pp. 794–796. doi:10.1097/00004583-200006000-00020
- Nagel, P. (2008). Moving beyond lecture: Cooperative learning and the secondary social studies classroom. *Education*, 128(3), 363-368.
- Norman, C.S., Rose, A.M. & Lehmann, C.M. (2004). Cooperative learning resources from the business disciplines. *Journal of Accounting Education*, 22(1), 1-28.
- Okon, B.O. (2001). An investigation into factors affecting science interest of secondary school students. *Journal of Research in science Teaching* 12(3) 11-19
- Omotere, A. (2011). The impact of teachers' teaching methods on the academic performance of primary school pupils in Ijebu-ode LGA of Ogun state. Available at www.omotere.tk.extractected in February, 2015
- Sadi, O., & Cakiroglu, J. (2011). Effects of hands-on activity enriched instruction on students' achievement and attitude toward science. *Journal of Baltic Science Education*, 10(2), 87-97.
- Schul, J. E. (2011). Revisiting an old friend: The practice and promise of cooperative learning for the twenty-first century. *Social Studies*, 102(2), 88-93.

Sharan, Y. (2010). Cooperative learning for academic and social gains: Valued pedagogy, problematic practice. *European Journal of Education*, 45(2), 300-313.

Yu-Fen, & Kai-Wen, (2009). The teaching context and approaches to study of accountancy students. *Issues in Accounting Education* 9 (1), 118-130.

APPENDIX

BENSON IDAHOSA UNIVERSITY, BENIN CITY FACULTY OF SOCIAL AND MANAGEMENT SCIENCES DEPARTMENT OF ACCOUNTING

RESEARCH QUESTIONNAIRE

SECTION A: (Please tick [] as appropriate to you)

1. Please indicate your level: 200 [], 300 [], 400 []
2. Please indicate your sex: Male [], Female []
3. Please specify your age range: 16 – 20 [], 21 – 25 []

SECTION B: Please use the scale below to answer the next set of questions

A – Lecture and Class Work

B – Lecture and Assignment

C – Class Discussion

D – Introduction of Technology into Lecture

Y – Yes

N – No

Please note that you can tick more than one strategy

4. Do you perceived teaching method as a tool for improving your performance level? Yes [] No []
5. What method(s) do you perceive will yield your best performance level? A [], B [], C [], D []

AUDIT, ASSURANCE AND CORPORATE GOVERNANCE

ACCOUNTANCY PROFESSIONAL ETHICS AND ASSESSMENT OF COMPLIANCE LEVEL BY THE NIGERIAN AUDITORS:

Abuh Adah

Department of Accountancy
College of Business and Management Studies
Kaduna Polytechnic, Kaduna
Email: adahconsults@yahoo.com
08036390115

Samaila Thompson

Department of Accounting
Faculty of Administration
Ahmadu Bello University, Zaria.
Email: samailathompson@yahoo.com
07030166799

Abstract

The primary objective of auditing is to enable the auditor to express professional and independent opinion on the true and fair view of financial statements of an enterprise. Auditing is governed by accountancy professional ethics. The Nigerian auditors are expected to comply with the ethics before the expression of their opinions in their assignments. The two professional accountancy bodies in Nigeria continuously clamouring for the relevance and compliance with the ethics, yet, it appears as if this effort has not been translated into action by the auditors either because of the low level of their competence or otherwise. The objective of this study is to find out whether Nigerian auditors, irrespective of their qualifications and competence status, comply with this professional ethics. This assertion becomes necessary as any audit team member is an auditor therefore becomes a determinant to the expression of the true and fair view which is a product of compliance with the professional ethics. Primary data in the form of questionnaires were used for the study. To achieve the objective of the study, analysis of variance (ANOVA) technique of data analysis was used. The study finds out that there are no significant differences among the three categories of auditors in the area of compliance with the ethics of the

profession. The paper recommends that there should be a method of measuring the level of compliance with the professional ethics by ICAN and ANAN and which must take into cognizance their qualification and competence to ensure healthier auditors' true and fair judgment. Any default should adequately be punished. Qualification and experience of who should act in the capacity of auditor should also be clearly redefined by the two professional accountancy bodies in Nigeria.

Keywords: Auditing, Auditor, compliance, professional ethic

Introduction

Auditing is not a new language in business or non-business environment. In any formal organization, auditing is fundamental as long as all owners or the major stakeholders will not act in the capacity of directors or managers in-charge of such organizations. Generally, the management of a company is entrusted to a board of directors or management to render the stewardship to the owners, at least once in a year. The separation of the owners and other major stakeholders from participation in managing the affairs of the company and also the need to safeguard the owners' interest will, by implication, require the service of an independent person. This person with the required competence is referred to as auditor.

The primary objective of auditing is to enable the auditor to express his professional and independent opinion on the truth and fairness of the financial statements of the company for a particular period or year. Any auditing that falls out of this objective will impair the integrity and credibility of both the auditor and the financial statements being reported upon. For the auditor to achieve this objective, he should be seen to be able to display professional sense of independence, objectivity and integrity even because of the expected great demand of the financial report by the diverse users. For these noble traits, he should have no interest in the financial information; his only interest is to ensure that his report reflects true and fair view which is the function of complying with the relevant standards, laws and implementation of the accountancy professional ethics.

For this research work, accountancy professional ethics will be focused or restricted to independence, objectivity and integrity. In carrying out any professional assignment, an auditor is expected to

have adequate and sufficient integrity, seen to be one and must be independent and objective if his report is to be adopted for decision making process by intended users.

The term, independence in relation to the professional auditor implies that he should strive to be self-directed and objective, free of interference by the entire client's staff up to the submission of his report and he is not to allow his work to be impaired by personal interests and or pressure. However, the independence in this context is more of attitude of the mind than a set of code of conduct. Objectivity as professional ethics requires an auditor to approach his work with integrity and objectivity and the approach must be with a spirit of independence of mind (Millichamp, 2000). An auditor must not be partial or allow his personal views to intervene in collecting all necessary audit evidences on which his opinion will be based.

The third proxy of the professional ethics in this study is integrity which cannot be separated from both objectivity and independence. Integrity is the vital and core value in the professional ethic. The auditor is a professional accountant and he must not only be a person of high integrity and independence but he must be seen to be an honest, candid, upright, decent and righteous person in carrying out any professional work. According to the International Organization of Supreme Audit Institutions (INTOSAI), integrity requires an auditor to observe the principles of independence and objectivity, maintain irreproachable standards of professional conduct, make decision with the public interest in mind and apply absolute honesty in carrying out his work. A violation may have a negative impact on his professional assignment.

The sole aim of compliance and maintenance of professional ethic is to provide for the users, a reasonable and acceptable assurance that financial information contented in the report/financial statements are reliable, objective, consistent and complete in all respects and comparable across the period covered by the report for their decision making. Another purpose is to abstain from professional misconduct and any act which may likely bring discredit to the auditor and the accounting profession. Auditors and accountants, as professionals, need to adhere to the codes of their professional ethics in order to produce reliable, relevant, accurate and comprehensive financial reports (Ogbonna, 2010).

The two professional accountancy bodies in Nigeria, International Federation of Accountants (IFAC), other professional bodies and other relevant standards/committees have continuously clamoured

for the relevance and need for compliance with the ethics in any professional assignment. It appears still that these have not been translated into action to the level of its awareness. The evidence can be taken from the various forms of business failure which are mainly attributed to the accountants in practice or the auditors not complying with the ethics and by implication facing ethical dilemmas (Erliden, Hermansson & Skirhammar as cited by Larsson & Wennerholm, 2006).

The most common and observed unethical practice that impairs the audit trait is that any audit team member in a client company answers the word auditor irrespective of his level of audit qualification (academic and professional) and competence. In some cases, some auditors' reports and opinions will be ready before the auditing itself since almost all the contents of auditor' report are constant and same. However, the ticking exercise must always appear on the financial records to justify the audit work. Less or no consideration will be given to auditing procedures and its utmost respect. It will be obvious that some of these groups of auditors will not understand and be able to comply with the ethics of the profession even though that their inputs always count in the expression of opinion.

From the issues highlighted in the preceding two paragraphs, the study will propose that:

- i. auditors with HND/BSc in the field with practicing certificates are likely to appreciate and ensure full compliance with the ethic of the profession;
- ii. Those with HND/BSc in the field with experience will ordinarily comply with the ethics; and
- iii. Those with other qualifications and experience will equally be less concerned with the issue of ethics even though their contribution takes integral part in the true and fair view judgment. For the purpose of addressing this proposition, the following research question becomes necessary.

Will it be feasible for the Nigerian auditors irrespective of their competence status to comply with the accountancy professional ethic?

The objective of this study is to find out whether there are differences among the three categories of auditors in compliance level with the ethics (independence, objective and integrity) of accountancy profession. This assertion becomes necessary as any audit team member is an auditor, therefore is a determinant to the

expression of the true and fair view. The true and fair view can represent a major product or component of compliance with the ethics of the accountancy profession. The outcome of this research work will be significant mainly to the accountants in practice or Nigerian auditors and the two professional accountancy bodies in Nigeria by reminding them the importance and need to embrace and emphasis on the ethic of the profession.

Literature Review

Concept of Auditing and Professional Ethics

As cited by Adeniji (2012) and Nwankwo (2006), "auditing is an independent examination of, and expression of opinion on, financial statements of an enterprise by an appointed auditor in pursuance of that appointment and in compliance with any relevant statutory obligation". Put in another direction, but in a more explanatory manner, it is an investigation or a search for evidence to enable an opinion to be formed on the truth and fairness of financial and other information by a person or persons independent of the preparer and persons likely to gain directly from the use of the information, and the issue of a report on that information with the intention of increasing its credibility and therefore its usefulness (Gray & Manson, 2007).

There are many more definitions of the term auditing yet the basic objective is the same, which is to enable the auditor to express his professional and independent opinion on the true and fair view of financial statements of an enterprise at a particular date. Auditing should be seen as an independent, objective and honest examination of all financial and related records of an organization. This includes obtaining information, verbally or documented as will assist the auditor in arriving at satisfactory evidence and conclusion on the financial information for the shareholders and other stakeholders to take decision as necessary.

Auditing is governed by the provisions of laws, standards and fundamentally the professional brainpower of the auditor that carries out the assignment. However, the determinant of auditor's mentality or attitude to auditing can only be approximated by the accountancy professional guidelines. These guidelines are primarily referred to as professional ethics in accountancy. The International Federation of Accountants (IFAC) as emphasized by the Institute of Chartered Accountants of Nigeria (ICAN) and Association of National Accountants of Nigeria (ANAN) provide that members in practice shall constantly maintain transparent independence, objectivity and

high integrity in carrying out the auditing assignment. This is in accordance with the public interest and the uniqueness of the profession.

The American Institute of Certified Accountants (AICPA) in its contribution maintains that: "In the performance of any professional service, a member shall maintain integrity, shall be free of conflicts of interest, and shall not knowingly misrepresent facts or subordinate his or her judgment to others. Members should accept the obligation to act in a way that will serve the public interest, honour the public trust, and demonstrate commitment to professionalism".

Henderson (1982) states that, the purpose of ethics or a code of ethics is to enable individuals and members in a profession to make choices among alternative behaviours. John (2009) is of the same view by stating that anyone who belongs to an association has a moral responsibility to behave and observe the rules of the association. This is because the accountancy profession is both cynical and responsive to the public and other users of financial statements. This feature, by implication, requires that the accountant in practice should be extra careful, attentive, methodical, loyal and observant in carrying out any professional assignment.

Campbel (2006) states that, ethics, that is truthfulness, honesty, care, loyalty, integrity: we know what they require, but we do not know if and how these requirements can be met. The key word is 'honesty' which always goes with integrity in audit practice. According to Grover (2005), honesty is seen to be a tendency not to tell lies, cheat or steal. In the same vein Smith (2003) sees honesty as a refusal to fake authenticity or to believe that particular facts are other than they are, whether to himself or any person. On the other hand, Sims (2000) states that lying is a statement that one knows to be bogus or believes to mislead with the intention to deceive others. If this indeed is the case, and we want to promote ethical auditing, then we need to attract decent people into the profession, train them well, and not subject them to more temptation than they can cope with. Maurice (1996) and Albrecht (1992) believe that once there is competence and expertise, moral sensibility, together with good example of senior colleagues that can take care of the ethical side of the profession, ethical will at least be promoted.

According to Campbel (2006), research into the ethics of accountants and auditors is a focus on discovering how to maximize compliance with generally accepted principles of professional conduct. According to Collste (1996), ethics deal with issues such as what individuals are

confronted with in their decision-making. On the other hand, Crane and Matten (2004) see ethics as the study of morality in order to explain specific rules and principles that determine right and wrong for any given situation. According to the study, morality is more of norms, values and beliefs that are part of a social process, which defines right and wrong.

Akadakpo and Izedonmi (2013) emphasize that accountants in practice are required to comply with local laws and should adhere to the ethical guidance. Nwanyanwu (2010) believes that ethical standards if strictly adhered to, become internalized and then will reflect extensively in professional assignments. Accounting is a profession that rests heavily on the need to exhibit a high sense of accountability and stewardship, hence the emphasis that all members be guided by professional code of conduct (Nwagboso, 2008).

Professional Ethics and Compliance by Auditors

Of recent, attention has been on the increase on the recognition and adoption of professional ethics mainly by the professionals whose services are required by the public; it becomes popular because of the recent corporate scandals. From the previous studies conducted on whether experience, knowledge, firm's size, and different kinds of pressures have any effect on auditors' ethical behaviours when confronted with the challenges of ethical dilemma (Sweeney & Roberts, 1997 and Lord & DeZoort, 2001), it is found that the independence of auditors is affected by the level of ethical reasoning of the individuals. It was also found that the audit profession is sometimes questionable, too subjective and that it must transform in order to maintain the public interest on the auditors' opinion.

The study of Lord & DeZoort (2001) also indicates that various factors are responsible for the auditors' judgment in expression of opinion. These factors include pressures from the environment, peer pressure and other social pressures. Erliden as cited by Larsson & Wennerholm (2006) is of the view that it is the increasing financial benefits and the threat of losing a client that could cause unethical practice. The author is of the opinion that it is imperative for an auditor to have individual responsibility and to act according to his own values when making a decision, rather by affecting the group pressure in their decision-making. In a similar study by Simnett (1996) who discusses whether experience and task complication affect an auditor in taking decision, it was concluded that experience

does not essentially have any significance in decision making process.

Larsson & Wennerholm (2006) are of the opinion that some business failures are due to unethical behaviour by auditors hence they have been faced by an increasing criticism during the last few years. In the same study, it is argued that the auditing profession is equally facing crisis of confidence and trust due to non maintenance of public trust. This is because of some remarks that auditors have to engage in unethical act for financial benefits such as fraud, social crime, even white-collar crimes, to occur. In line with this ugly observation, Abdolmohammadi and Scarbrough (2003) posit that the auditing profession is forced to reform with a view to improving the ethical reasoning of auditors for the public interest and confidence.

Mitchell, Sikka & Willmott (1998) state that, to restore the glory and goodwill in the auditing profession and also to prevent future financial scandals, the demands on the profession to adopt professional ethic have to be increased. A code of ethics should be seen as a requirement by the profession (Boatright, 1999). It is an important component in forming a profession and really ethics that professionals will have to act in a manner that will be well above the minimum requirements (Smith, Smith & Mulig, 2005).

Methodology

The objective of this study has led to the use of primary data in the form of questionnaire. The primary data was collected through distribution of enclosed questionnaire to auditors or accountants in practice within Kaduna, Kano and Zaria metropolis that were selected at random. In addition, secondary data were collected from relevant journals and text books in order to supplement the primary data and also to provide an insight to the study.

Three hundred and fifty (350) questionnaires were distributed. The questions were formulated based on the 6-point Likert type response scale; 6 strongly agree, 5 agree, 4 fairly agree 3 fairly disagree, 2 disagree and 1 strongly disagree. To measure the scale, 12 items were covered in the questionnaire. The questionnaires were specifically distributed to staff (all audit staff in the capacity of auditor including partners) of practising firms. The questionnaire was designed in order to give the respondents the chance to rate their perceived compliance with ethics of the profession and indicating his/her category. The three categories are A: those with HND/BSC in the field with practising certificates, B: those with HND/BSC in the

field with experience and C: those with other qualifications and experience. Three hundred and twenty three (323) completed questionnaires, representing about 92% were retrieved from the respondents.

The 323 retrieved questionnaires were analysed using analysis of variances (ANOVA) model to test the views of the respondents. The ANOVA model was chosen because the objective of the study is to compare the means scores of the three types of respondents in compliance with ethic of the profession. The objective is to find out whether there are significant differences in the mean scores of respondents in categories. An overall mean score was obtained for the scale by summing the answers given to the 12 items.

Results and Discussion

Cronbach’s Alpha coefficient test was conducted using SPSS to check the internal consistency (reliability) for the scale in the respondents to the questionnaires. The result was 0.73, it is satisfactory as it was a little above the benchmark of 0.70 (Pallant, 2007).

Table 1: Descriptive Statistics

	N	Mean	Std. Deviation
Category A	101	3.4831	.46190
Category B	104	3.4167	.41610
Category C	118	3.3963	.34447
Total	323	3.4337	.40773

Source: Authors’ computations

From Table 1 above, the mean scores and standard deviations obtained based on the total scores of compliance with ethics of the profession scale was presented. From the table, auditors reported an overall (total) moderate compliance with the ethic of accountancy profession with mean scores around the intermediate 3.4 in the six-point scale.

Table 2: Test of Homogeneity of Variances

TAC4

Levene Statistic	df1	df2	Sig.

Table 2: Test of Homogeneity of Variances

TAC4

Levene Statistic	df1	df2	Sig.
6.772	2	320	.001

Source: Authors' computations

This test of homogeneity of variance in Table 2 above appears to have violated the assumption of ANOVA because the Levene's test revealed a significant value. This test shows whether the variance in scores is the same for each of the three groups. For the significant result recorded, it becomes necessary to conduct the Robust Tests of Equality of means.

Table 3: Robust Tests of Equality of Means

TAC4

	Statistic ^a	df1	df2	Sig.
Welch	1.579	2	202.945	.209
Brown-Forsythe	1.415	2	289.837	.245

a. Asymptotically F distributed.

Source: Authors' computations

From Table 3 above, the Robust Tests of Equality of Means show that both the Welch and Brown-Forsythe tests reveal insignificant values. Based on this result, we proceeded with the ANOVA test of significance.

Table 4: Results from ANOVA

Total Auditors' Compliance

	Sum of Squares	Df	Mean Square	F	Sig.
Between Groups	.480	2	.240	1.448	.236
Within Groups	53.051	320	.166		
Total	53.531	322			

Source: Authors' computation

From Table 4 above, estimate of the variability for the mean square given by the model is .240 for between groups and the mean of .166

for within groups. The ratio of this mean square is 1.448 and appears too insignificant to reject any null hypothesis. In order to find out whether statistically significant differences exist in the mean scores on the dependent variable (compliance with ethics of the profession) amongst the three categories of practising auditors, One-way Analysis of Variance (ANOVA) was conducted.

The result displayed by Table 2 below shows that there is no statistically significant difference ($p > 0.5$) in the compliance level with the ethics of accountancy profession scores for the three categories of practising auditors: $F(2, 320) = 1.448, p = 0.236$. In addition, the effect size calculated using eta squared was .008. Thus, besides not reaching statistical significance, the actual difference in mean scores between the three categories of practising auditors (considering the value of the effect size) is very small (Cohen, 1988). Based on this result, there is no need to conduct post-hoc analysis in order to show where differences exist among the three categories.

The result of this study is not in agreement with the study of Maurice (1996) and Albrecht (1992) who believe that competence and expertise can lead to compliance with the ethic of accounting profession. However, the result of this work is in concordance with the view of Simnett (1996) who discusses whether experience in auditing practice can affect compliance and in taking decision; it was concluded that experience does not essentially have any significance in decision making process.

Conclusion

The objective of the study is to find out whether Nigerian auditors, irrespective of their competence level can appreciate and ensure reasonable compliance with the ethics (independence, objective and integrity) of accountancy profession. For this purpose, the respondent auditors were classified into three categories A, B and C. A represents those with HND/BSc in the field with practising certificate; category B represents those with HND/BSc in the field with experience and the third group C are those with other qualifications but with experience. From the data analysis and findings, the study concludes that there are no statistically significant differences among the three categories of auditors in compliance with ethics of the profession. The statistical result also concludes that the effect size calculated using eta squared was .008. That is, the actual difference in the mean scores between the three categories of practising auditors is very small.

The paper recommends that there should be a method of measuring level of compliance with the professional ethics by ICAN and ANAN and which must take into cognizance, qualification and competence to ensure healthier auditors' true and fair judgment. Any default should adequately be penalized. Qualification and experience of whoever should act in the capacity of auditor should also be clearly redefined by the two professional accountancy bodies in Nigeria.

Reference

Abdolmohammadi, M., Read, W. & Scarbrough, D. (2003); Does Selection-Socialization Help to Explain Accountants' Weal Ethical Reasoning? *Journal of Business Ethics*. Vol.42, 71- 81

Adeniji, A. A. (2012); *Auditing and assurance services* (2nd ed.), Value Analysis Consult: Lagos
Akadakpo and Izedonmi (2013); Ethical practices of the professional accountants in Nigeria. *Research Journal of Finance and Accounting*, Vol. 4 No. 7

Albrecht, W. S. (1992); *Ethical Issues in the Practice of Accounting*, South-Western Publishing, Cincinnati, OH.

Artsberg, K. (2005); *Redovisningsteori – policy och –praxis*. Malmö: Liber Ekonomi

Behrman, J. N. (1988); *Professionals and professionalism in essays on ethics in business and professions*. Enlewood Cliffs: J. N. Prentice Hall.

Boatright, J. R. (1999); *Ethics in Finance*. Malden: Blackwell Publishers

Campbel, T. (2006); Introduction: The ethics of auditing

Cohen, J. W. (1988); *Statistical power analysis for the behavioural sciences* (2nd ed.). Hillsdale, NJ: Lawrence Erlbaum Associates.

Collste, G. (1996); *Inledning till etiken*. Lund: Studentlitteratur

Crane, A. & Matten, D. (2004); *Business ethics: a European perspective: managing corporate citizenship and sustainability in the age of globalization*. Oxford: Oxford University Press

Donnelly, J. H., Gibson, J. L. & Ivancevich, J. M. (1987); *Fundamentals of management*, (6th ed.), Illinois: Irwin

Gray, I & Manson, S (2007); *The audit process, principles, practice and cases*. (3rd ed.), Padstow, Cornwall: Thomson Learning

Grover, S. L. (2005); The truth, the whole truth and nothing but the truth: The causes and management of workplace lying. *Academy of Management Executive* 19 (2): 148-57.

Henderson, V. E. (1982); The ethical side of enterprise: Sloan Management Review. Summer, 38

INTOSAI (nd). Concept, background and purpose of the code of ethics, *IXth Congress of INTOSAI, meeting, Lima*.

John, E. I. (2009); *Financial reporting and ethics: PE II ICAN examination distance learning pack*. Accounting Training and Publication Ltd: Lagos

Larsson, M. & Wennerholm, C. (2006); *Ethics in the auditing profession - a comparison between auditors and students*. Master thesis in Auditing

Lord, A. & DeZoort, F. (2001); The impact of commitment and moral reasoning on auditors' responses to social influence pressure. *Accounting, Organizations and Society*. Vol. 26, 215-235

Maurice, J. (1996); *Accounting Ethics*, Pitman Publishing, London.

Millichamp, A. M. (2000); *Auditing*, (7th ed.), London: Ashford Colour Press.

Mitchell, A., Sikka, P. & Willmott, H. (1998); Sweeping it under the carpet: the role of accountancy firms in moneylaundering. *Accounting, Organizations and Society*. Vol. 23, 589-607

Nwagboso, J. (2008); *Professional Ethics, Skill and Standards*. Jos, Nigeria: Inspiration Media.

Nwankwo, I. O. (2006); *Auditing concepts, issues and principles* (1st ed.). IONAE Investment Company: Lagos

Nwanyanwu, L.A. (2010); Internalisation of ethics and professional practice in Nigeria: The accountant's perspective. *International Research Journal Finance Economic*, 56, 82-87.

Ogbonna, G. N. (2010); Ethical considerations in corporate governance: A Survey of governance practices of corporate stakeholders in Nigeria. *International Journal of Business Behaviour Sciences Research*, 1(1), 91-108.

Pallant, J. (2007); *SPSS survival manual: A step by step guide to data analysis using SPSS for windows* (3rd Ed). McGraw Hill Open University Press: England

Simnett, R. (1996); The effect of information selection, information processing and task complexity on predicative accuracy of auditors. *Accounting, Organizations and Society*. Vol. 21, 699-719

Sims, R. L. (2000); The relationship between employee attitudes and conflicting expectations for lying behavior. *Journal of Psychology* 134 (6): 619-33.

Smith, T. (2003); The metaphysical case for honesty. *Journal of Value Inquiry* 37 (4): 517-31.

Smith, L., Smith, K. & Mulig, E. (2005); Application and Assessment of an Ethics Presentation for Accounting and Business Classes. *Journal of Business Ethics*. Vol. 61.

Sweeney, J. & Roberts, R. (1997); Cognitive moral development and auditor independence. *Accounting, Organizations and Society*. Vol. 22, 337-352

PUSHING FOR JOINT AUDIT IN NIGERIA

Jinadu, Olugbenga (MSc, ACA) ^{1*}Ojeka, Stephen Aanu
(PhD)²Agbeyangi, Babatunde Adisa(MSc, FCA)³

1. Department of Accountancy, Rufus Giwa Polytechnic, Owo,
Ondo State, Nigeria
olugbengajinadu@yahoo.com
2. Department of Accounting, Covenant University, Ota, Ogun
State, Nigeria
stojeka@yahoo.com
3. Department of Accountancy, Federal Polytechnic, Ilaro, Ogun
State, Nigeria
baagassociates@yahoo.com

Abstract

This study examines whether the decision to engage two audit firms to conduct a joint audit would be associated with audit quality and earnings quality. The data on the perception of accounting academics and professionals was gathered through the use of a structured questionnaire. Analyses were carried out using Mean and ANOVA methods tested at 5% significance level. The Findings revealed that the engagement of joint auditors would not contribute positively to audit quality, higher earnings quality and would increase the cost of audit. It was therefore recommended that a voluntary joint audit would be a strategy to promote compliance with the regulations, build capacity of small and medium-sized practitioners, raise the quality of financial reporting and increase the confidence of investors and the general public.

Keywords: Audit fees, Audit quality, Earnings quality, Engagement partners, Joint audit

1. Introduction

The global financial crisis has raised many questions about the quality of external audits. A significant regulatory concern remains that the audit market is held in the hands of only four large

international audit networks (the Big 4) after the Enron scandal in the early part of this century and the subsequent demise of Arthur Andersen in 2002 (Nicole, Sophie, Jaana & Cedric, 2012). In fact, besides the big 4, the small and medium practising firms in Nigeria in terms of size and revenues are to take advantage of the emerging business opportunities as envisaged by the Local Content Act 2010 (Ajaegbu, 2014). As part of the Institute of Chartered Accountants of Nigeria strategies to enhance technical capacity of small and medium size practices and by extension financial reporting, UHY Maaji & Co and PWC were appointed in August 2014 to jointly plan, execute, sign the auditors' report and share rewards in line with agreed proportion (Nigeria-Today, 2014; Ajaegbu, 2014). A joint audit therefore is an audit in which the financial statements are audited by two (or more than two) independent auditors with shared audit effort (Thisday, 2014).

In Nigeria, every company registered under the Company and Allied Matters Act (CAMA 2011) is required to appoint an auditor or auditors at each annual general meeting to audit the financial statements and express an opinion on the state of the financial position, financial performance and cash flows of the company. This is obviously in compliance with the global best practice of ensuring accountability and transparency in organisational management and at sustaining shareholders and other stakeholders' confidence and value. Therefore, the appointment of a single auditor or joint auditors has over the years, become common practice in Nigeria and shareholders of companies, who deem it fit, have continued to appoint more than one auditor for their audit of financial statements. Joint Audits are therefore not new in Nigeria. What is new is the attempt by some interested individuals to make compulsory the appointment of joint auditors by all publicly quoted companies in Nigeria. However, the main issues in this study are whether joint audit will guarantee improved auditing quality; enhance the quality of earnings and increase the costs of audit for companies in Nigeria.

The focus on joint audit is important because it is possible to address most of the teething issues about audit quality raised in the green paper¹ on market concentration and cost increases in mandating the audit (European Commission, 2010) and to exploit factors underlying the benefits of joint audits through the appointment of two engagement partners. Firstly, with a situation involving one

engagement partner, two distinct auditors working together are likely to have more technical expertise to make judgments and audit complex reporting businesses. Secondly, an engagement with two partners will benefit from the broader networks and geographical coverage that are important when auditing diversified clients.

This study contributes to the extant audit literature by examining the topic of joint audits in Nigeria, addressing in particular the benefits and costs associated with joint audits. More specifically, it will examine whether joint audits are associated with audit quality, earnings quality and audit fees. The paper also contributes to the joint audit literature in two ways. First, it attempts to provide an overview of the joint audit by presenting and discussing evidences and cautions. Secondly, it emphasises the lack of empirical evidence in Nigeria and proposes avenues for future research so as to allow for a more thorough understanding of joint audit and its impacts. The purpose of this paper is to examine whether the practice of using two audit engagement partners will enhance audit quality, increase earnings quality and audit fees in Nigeria.

2. Literature Review

The system of employing two engagement partners to audit a firm may be used to achieve the benefits derivable from having joint audit firms (Ittonen & Tronnes, 2015). First, two engagement partners working together have more experience and technical expertise to make judgments and provide assurance on complex transactions. Secondly, two engagement partners are also likely to benefit from a broader network of experts and broader geographical coverage. Thirdly, appointing two engagement partners provides a way to reduce the loss of client-specific knowledge when the engagement partner rotates. Finally, there will be an improved resistance to threats to independence as compared to an audit conducted by a single audit partner. Although, the potential benefits and costs of appointing two engagement partners have not been investigated before in Nigeria. The benefits described above suggest that the stream of literature that has examined joint audits at the firms' level is highly relevant for the context of this paper and for hypotheses development.

The argument in favour of joint audits is that they increase audit quality because joint auditors have the potential to address two underlying principles of audit quality: auditor competence and independence. Firstly, the audit procedure decisions and judgments of partners are expected to be of higher quality when they are benchmarked against a jointly-liable partner, whereas in single audits there is less pressure to justify one's judgments and decisions to others. Furthermore, prior research generally shows that experience and expertise are associated with improved performance (Brown & Johnstone, 2009; Chin & Chi 2009).

Prior studies on joint audits have used data from both mandatory and voluntary settings. Studies investigating mandatory settings mainly focused on examining the costs and benefits of different joint audit structures, because the direct comparisons to single audits cannot be made, and studies examining voluntary settings compare joint audits with single audits.

In the mandatory environment, Holm and Thinggaard (2012) investigate the consequences and implications for companies changing from joint audits to single audits following the abandonment in 2005 of the joint audit requirement for listed companies in Denmark. Holm and Thinggaard (2012) find a fee reduction of around 16 percent for firms that change to single audits, which they mainly attribute to increased competition while noting that efficiency gains may offer a partial explanation. They find no difference in earnings quality between joint audits and single audits. In a similar setting, Haapamaki, Järvinen, Niemi, and Zerni, (2012) investigate whether voluntary joint audits offer value for money in Sweden between 2001 and 2007. They find that voluntary joint audits are associated with an increased earnings quality. As suggested in the Green Paper (European Commission, 2010) the empirical evidence on joint audits suggests that the joint audit system may be an effective mechanism to prevent market concentration and low competition (Piot, 2007). The comments filed against the suggestions in the Green Paper (European Commission, 2010) indicate that client firms oppose increases in audit costs and this is supported by empirical evidence indicating that client firms, in general, perceive joint audits as a net burden and prefer single audits given the choice (Holm & Thinggaard, 2012)

Opponents of mandatory joint audits present two main arguments that joint audits do not increase audit quality. First, joint audits may suffer from a potential 'free-rider problem'. This problem may occur if one of the auditors attempts to 'avoid responsibility' and rely on the other auditor's effort during the audit. Second, it may be difficult for two competitive audit firms to cooperate closely while conducting the audit, resulting in insufficient information exchange. Competition between auditors aiming to acquire a larger share of the business in the upcoming years may hinder cooperation and even compromise audit quality because of insufficient information exchange. Moreover, accounting standards containing considerable discretion can make cooperation difficult and lead to conflicts (Neveling, 2007).

Several studies have attempted to evaluate the potential additional cost of a joint audit system. Holm and Thinggaard (2011) examine the impact of joint audit on audit costs measured by audit fees in Denmark. Their findings suggest that companies opting for a single auditor can benefit from fee discounts. However, fee discounts can only be observed in the first year after the switch from a joint to a single audit. Their results also suggest that the fee reduction is driven by single audit firms that previously benefitted from a significant stake in the former joint audit. The authors thus conclude that the reduction in audit fees after switching from joint to single audit is a consequence of initial fee discounts due to competition. Lesage, Ratzinger-Sakel and Kettunen, (2012) also examine the impact of joint audit on audit fees in Denmark. Their findings confirm for either period that joint audits are associated with higher audit fees. However, they find no significant association with total fees, comprised of audit and non-audit service fees.

The Ittonen and Peni (2012) study sheds light on the impact of the voluntary joint audit on audit fees. Based on a sample of 715 non-financial companies listed in the NASDAQ OMX exchanges in Denmark, Finland and Sweden in 2007, the authors find that joint audit is associated with lower audit fees. Conversely, Zerni, Haapamäki, Järvinen and Niemi, (2012), who also examine the impact of joint audit on audit fees in Sweden for the period of 2000-2006, show that opting for joint audit generates additional costs. More specifically, clients with two auditors pay significantly higher audit fees than clients audited by a single auditor.

The concentration of the audit market in the hands of very few large Firms of auditors is a concern that has focused the attention of both regulators and researchers (Wolk, Michelson & Wooton, 2001, in the US; Beattie, Goodacre & Fearnley, 2003, in the UK). An increased market concentration and perceived lower level of market competition creates the possibility of abnormally high prices due to monopoly rents and suboptimal audit quality due to an absence of effort and investments. In the Green Paper, the EC indicates that the current level of audit market concentration creates a systemic risk because the collapse of another big international audit network would significantly disrupt the audit market dynamics and suggests that joint audits could be used to reduce the concentration of the audit market (Quick, 2012).

South Africa has regulations on joint audit since 1973, although these have become less demanding over time. The initial provision in the 1973 Companies Act (South Africa, 1973) stated that for large firms meeting certain conditions 'The Minister may at any time appoint an auditor to act jointly with any other auditor of the company. This no longer exists in a new Companies Act adopted in 2008 (enforced as of 2011). In the banking industry, from 1990, joint audit was mandatory for large banks with total assets greater than 10 billion rand (approx. €972 million). However, following the amendment of the Bank Act in 2003, this requirement no longer exists (South Africa, 2003).

This study finds that there is only limited evidence that joint audit leads to increased audit quality, whilst there are some evidences that joint audit leads to additional costs. A further interest is the finding that joint audits can potentially enhance competition and thus reduce market concentration. There is no empirical evidence to demonstrate clearly that this improves audit quality. The inconclusive evidence demonstrates that the full impact of joint audit is still not known and that further research is required prior to implementing any policy on joint audit. The research also highlights the practical challenges that need to be overcome if a policy of joint audit is to be introduced.

The above and prior findings with regard to joint audits on the firms' level, lead to the following hypotheses that:

H₁: Joint audits are not significantly associated with audit quality.

H₂: Earnings quality is higher for companies audited by two audit firms than for companies audited by a single audit firm.

H₃: Audit fees are higher for companies audited by two audit firms than for companies audited by a single audit firms

3. Research Methods

The focus of the study is to examine whether pushing for joint audit in Nigeria would be associated with audit quality and earnings quality. The study employed a survey instrument which consists of three scenarios. The three scenarios concern the decision of a client whether to engage 2 small audit firms or 2 big4 audit firms or 1 big4 firm and 1 small firm as joint auditors. Respondents were expected to respond to anyone of the scenarios. Our target population comprised the Accountants in academic and those in practice. The respondents were asked ten questions from each of the scenarios; three of which measured audit quality, earnings quality and audit fees. The other questions measured the benefits and challenges from the use of joint audit in Nigeria.

For the purpose of this survey, 68 respondents were sampled. In the choice of the population for this study, the researcher used a judgemental sampling technique purposive towards Accountants in academic and those in practice in Ondo and Ekiti State. The primary and secondary methods of data collection were employed. The researchers used questionnaire and oral interview to collect the primary data, while secondary data were sourced from journals and professional publications. The 68 questionnaires were duly filled and returned to the researchers. Respondents were subjected to three scenarios in which they were advised to limit themselves to anyone of the scenarios on the basis of benefits and challenges of the topic to Nigerian environment. The questionnaire was designed in a 5-point likert form scale: Strongly Disagree to Strongly Agree. The researchers shared the questionnaire in the offices of the respondents. The data were statistically analysed using Mean and ANOVA F-statistic technique with the aid of Statistical Package for Social Sciences (SPSS) version 15, which was tested at 5% significance level. It is a method used to analyse variations between groups and the effect of total variation of some factors.

4. Data Analysis and Presentation

Data collected from primary source through questionnaires and oral interview were statistically presented and analysed. Frequency, tabular percentage, means and ANOVA were used to test the hypotheses. The administration of the questionnaire is as shown in table 1 below:

Table 1: Respondents' response

	NO. OF RESPONDENTS	PERCENTAGE	ACCOUNTANTS IN	
			ACADEMICS	PRACTIC E
SCENARIO 1	26	38	16	10
SCENARIO 2	11	16	7	4
SCENARIO 3	31	46	11	20
TOTAL	68	100	34	34

Source: Field survey, 2015

Discussion of Findings

Table 1 shows that 26 respondents, in the first scenario, representing 38% of the respondents accepted the use of 2 small audit firms as joint auditors, and the implication is that two small firms will dominate the audit market, enhance economic empowerment and build capacity of small audit practices. In the second scenario, Eleven (11) respondents representing 16% agreed to the use of 2 Big4 audit firms as joint auditors. The effect of this is that the domination of big 4 firms will not create economic space for small firms and there would be increase in market concentration. From scenario 3, 31 respondents representing 46% opted for 1 Big4 and 1 small audit firm as joint auditors and this implies that the audit market dominance by the big firms will be reduced and there will be economic space for more accounting professionals which will enhance the quality of financial reporting.

Table 2: Mean response on whether a client should engage in any of the scenario cases

S/ N	Research Questions	Scenar io 1	Scenar io 2	Scenar io 3	Test of Mean Significan ce at 5%	Decisio n
		Mean Response				
1.	Mandatory Joint Audit type preferred	3.85	4.00	3.32	3.72	Reject Scenari o 3 & Accept Scenari o 1&2
2.	Voluntary Joint Audits type preferred	2.54	2.09	3.61	2.75	Reject Scenari o 1&2 and Accept Scenari o 3
3.	Contribute positively to audit quality	4.04	4.27	4.39	4.23	Reject Scenari o 1 & Accept Scenari o 2&3
4.	Assist small audit practices to build capacity	4.23	3.73	4.58	4.18	Reject Scenari o 2 & Accept Scenari o 1&3
5.	Create more economic space for Accounting Profession als	4.42	4.36	4.61	4.46	Reject Scenari o 1&2 and Accept Scenari o 3
6.	Increase in investors'	4.27	4.27	4.26	4.27	Reject Scenari

	confidence					o 3 and Accept 1&2
7.	Associated with higher earnings quality	3.69	4.27	4.23	4.06	Reject Scenario 1 and Accept Scenario 2&3
8.	Increase in audit fees	3.54	3.55	3.71	3.60	Reject Scenario 1&2 and Accept Scenario 3
9.	Conflict between audit firms	2.65	3.64	3.19	3.16	Reject Scenario 1 and Accept Scenario 2&3
10.	Auditors jointly liable for the issued audit opinion	4.08	4.09	4.29	4.15	Reject Scenario 1&2 and Accept Scenario 3

Source: Author's Computation from SPSS, version 15.0

Table 2 shows respondents' view on the mean response on whether a client should engage in any of the scenarios. On the basis of mandatory joint audit, respondents show high measure of preference for scenario 1 and scenario 2 only. Also, for voluntary joint audit, where auditors are jointly liable for the issued audit opinion, respondents show high measure of preference for scenario 3 only.

On Audit quality, respondents show high measure of preference for scenario 2 and scenario 3 only. In terms of assisting small audit to build capacity as well, respondents show high measure of preference for scenario 1 and scenario 3 only. In terms of higher earnings quality and conflict between audit firms, respondents also show high degree of preference for scenario 2 and 3 only. In addition, for the provision of economic spaces for accounting professionals and increase in audit fees, respondents show high measure of preference for scenario 3 only. Increase in investors' confidence is highly appraised for scenario 1 and 2 only. However, it was observed that majority of the respondents agreed with scenario 3 case due to its overriding effect of acceptability among the other scenarios in the research study.

Table 3: F-statistic value on ANOVA comparing means among the scenarios for joint audit in Nigeria

S/N	Research Questions	F-statistic value	Degree of Freedom (DF)	Significance (P-value)	Test of Significance at 5%	Decision
1.	Mandatory Joint Audit type preferred	1.411	67	0.251	0.05	Accept H ₁
2.	Voluntary Joint Audits type preferred	7.961	67	0.001	0.05	Reject H ₁
3.	Contribute positively to audit quality	1.466	67	0.238	0.05	Accept H ₁
4.	Assist small audit practices to build capacity	3.322	67	0.042	0.05	Reject H ₁

5.	Create more economic space for Accounting Professionals	0.867	67	0.425	0.05	Accept H ₃
6.	Increase in investors' confidence	0.002	67	0.998	0.05	Accept H ₃
7.	Associated with higher earnings quality	3.457	67	0.037	0.05	Reject H ₂
8.	Increase in audit fees	0.171	67	0.843	0.05	Accept H ₃
9.	Conflict between audit firms	3.164	67	0.049	0.05	Reject H ₂
10.	Auditors jointly liable for the issued audit opinion	0.407	67	0.668	0.05	Accept H ₁

Source: Author's Computation from SPSS, version 15.0

Table 3 shows the F-statistic value on ANOVA that compare means among the scenarios for joint audit in Nigeria. The respondents which are basically accounting academics and professionals show equal level of preference for a mandatory joint audit type between the scenarios. We therefore accept H₁ and conclude that mandatory joint audits are not significantly associated with audit quality. Also, the respondents do not show equal measure of preference for a voluntary joint audit type among the scenarios. We therefore reject H₁ and conclude that voluntary joint audits are significantly associated with audit quality. The respondents show equal level of

preference for joint audit as it contributes positively to audit quality. We therefore accept H_1 and conclude that joint audit is not significantly associated with audit quality. On earnings quality, respondents do not show equal measure of preference. Based on this, H_2 is rejected and it is concluded that earnings quality is not higher for companies audited by two audit firms than for companies audited by a single audit firm. The respondents also show equal measure of preference for joint audit as it creates more economic space for accounting professionals, increase in investors' confidence and higher audit fees within the scenarios. H_3 is therefore accepted and it means that audit fees are higher for companies audited by two audit firms than for companies audited by a single audit firms.

4.1 Decision

From the result of analysis in tables 1, 2 and 3 above, it was observed that the engagement of two audit firms for a client would not contribute positively to audit quality, higher earnings quality and would also increase the cost of audit. However, there is no empirical evidence that joint audit leads to increased audit quality as seen from the literature with regard to Holm & Thinggaard (2012), and also in a country like Denmark and South Africa where joint audit became less demanding.

5. Conclusion and Recommendations

This study examines whether the decision to engage two audit firms to conduct a joint audit will be associated with audit quality and earning quality in Nigeria. The findings indicate that the engagement of joint auditors is not associated with audit quality and higher earnings quality. In the same vein, the decision to engage joint auditors does not come without additional costs. Therefore, the fees charged may be considered as an indication of the client firm's willingness to pay more for a higher and perceived audit quality and to enable a greater reliance on financial statements.

Given the nature of the Nigerian audit market and its dominance by the big firms, voluntary joint audit will be appropriate for the government and practitioners as a strategy to promote compliance with regulations, build capacity of small and medium-sized practitioners,

and increase the quality of financial reporting, raise the confidence of investors and the general public. Audit quality could therefore be enhanced through monitoring and enforcement of standards by the regulators for all audit firms.

REFERENCES

- Ajaegbu, C. O. (2014). Case for joint audit: preamble. Retrieved 14/1/2015 http://www.icanig.or/ican/.../ican_case_for_joint_audit_final.pdf,
- Beattie, V., Goodacre, A. and Fearnley, S. (2003). And then there were four: A study of UK audit market concentration-causes, consequences and the scope for market adjustment, *Journal of Financial Regulation & Compliance*, 11(3): 250.
- Brown, H., and Johnstone K. M. (2009). Resolving disputed financial reporting issues: Effects of auditor negotiation experience and engagement risk on negotiation process and outcomes. *Auditing: A Journal of Practice & Theory* 28 (2): 65–92.
- Chin, C., and Chi H. (2009). Reducing restatements with increased industry expertise. *Contemporary Accounting Research* 26 (3): 729–765.
- European Commission (2010). Audit policy: Lessons from the crisis. Brussels, *Green Paper*. Retrieved 28/1/2015 from http://www.ec.europa.eu/internal_market/auditing/docs/liability/auditliability.en.
- Haapamäki, E., Järvinen T., Niemi L. and Zerni M. (2012). Do joint audits offer value for money? Abnormal accruals, earnings conservatism, and auditor remuneration in a setting of voluntary joint audits. *European Accounting Research*, Forthcoming.
- Holm, C. and Thinggaard, F. (2011). Joint audits – benefit or burden?, Retrieved 28/1/2015 from <http://www.papers.ssrn.com>
- Holm, C. and Thinggaard, F. (2012). Balancing auditor choices during the transition from a mandatory to a voluntary joint audit system in Denmark, Retrieved 28/1/2015 from <http://www.aaahq.org/AM2012/display.cfm?>

- Ittonen, K. and Peni, E. (2012). Auditor's gender and audit fees, *The International Journal of Auditing*, 16(1): 1-18.
- Ittonen, K. and Tronnes, P. C. (2015). Benefits and costs of appointing two engagement partners, *Auditing: Journal of practice and Theory* 05/2014, 33(2): 1-25
- Lesage, C., Ratzinger-Sakel, N. and Kettunen, J. (2012). Struggle over joint audit: On behalf of public interest?' *working paper*.
- Neveling, N. (2007). French CFO attacks joint audit, *Accountancy Age*, 4.
- Nicole R., Sophie A., Jaana K. & Cedric L. (2012). What do we know about joint Audit? A report published for the Research Committee of the Institute of Chartered accountants of Scotland (ICAS). Edinburgh, *ICAS insight publication*, 1-50.
- Nigeria Today (2014). *ICAN: appointment of UHY Maaji & Co as joint auditors with PWC*-advertorial. http://www.icanig.or/ican/.../ican_case_for_joint_audit_final.pdf, accessed 14/01/2015
- Piot, C. (2007). Auditor concentration in a joint-auditing environment: the French market 1997-2003. *Managerial Auditing Journal*, 22: 161-176.
- Quick, R. (2012). EC Green Paper proposals and audit quality, *Accounting in Europe*, 9(1): 17-38.
- South Africa (1973). *Companies act (act no. 61 of 1973)*, Retrieved 3/2/2015 from <https://www.saica.co.za>
- South Africa (2003). *Banks amendment act (act no. 19 of 2003), section 42*. Retrieved 18/1/2015 from <http://www.info.gov.za>.
- Thisday (2014). Should mandatory joint audit be adopted in Nigeria? BusinessICAN. Retrieved 23/3/2015 from <http://www.thisdaylive.com>.
- Wolk, C. M., Michelson, S. E. and Wooton, C. W. (2001). Auditor concentration and market shares in the US: 1988-1999 a descriptive note, *The British Accounting Review*, 33(2): 157-174.

Zerni, M., Haapamäki, E., Järvinen, T. and Niemi, L. (2012). Do joint audits improve audit quality? Evidence from voluntary joint audits. *European Accounting Review*, 1-35.

APPENDIX

MEANS TABLES=Q1 Q2 Q3 Q4 Q5 Q6 Q7 Q8 Q9 Q10 BY Scenario
/CELLS MEAN COUNT STDDEV /STATISTICS ANOVA. [DataSet0]

Table 1: Case Processing Summary

	Cases					
	Included		Excluded		Total	
		Percent	N	Percent	N	Percent
Q1 * Scenario	68	100.0%	0	.0%	68	100.0%
Q2 * Scenario	68	100.0%	0	.0%	68	100.0%
Q3 * Scenario	68	100.0%	0	.0%	68	100.0%
Q4 * Scenario	68	100.0%	0	.0%	68	100.0%
Q5 * Scenario	68	100.0%	0	.0%	68	100.0%
Q6 * Scenario	68	100.0%	0	.0%	68	100.0%
Q7 * Scenario	68	100.0%	0	.0%	68	100.0%
Q8 * Scenario	68	100.0%	0	.0%	68	100.0%
Q9 * Scenario	68	100.0%	0	.0%	68	100.0%
Q10 * Scenario	68	100.0%	0	.0%	68	100.0%

Table 2: Report (Mean report on whether a client should engage in any of the scenarios)

Scenario		Q1	Q2	Q3	Q4	Q5	Q6	Q7	Q8	Q9	Q10
Scenario1	Mean	3.85	2.54	4.04	4.23	4.42	4.27	3.69	3.54	2.65	4.08
	N	26	26	26	26	26	26	26	26	26	26
	Std. Deviation	1.156	1.363	.774	1.177	.703	.874	.884	1.067	.977	.977
Scenario2	Mean	4.00	2.09	4.27	3.73	4.36	4.27	4.27	3.55	3.64	4.09
	N	11	11	11	11	11	11	11	11	11	11
	Std. Deviation	.775	1.136	.467	.786	.505	.647	.905	1.293	.809	.701
Scenario3	Mean	3.32	3.61	4.39	4.58	4.61	4.26	4.23	3.71	3.19	4.29
	N	31	31	31	31	31	31	31	31	31	31
	Std. Deviation	1.739	1.256	.844	.807	.667	.729	.762	1.243	1.376	1.006
Total	Mean	3.63	2.96	4.24	4.31	4.50	4.26	4.03	3.62	3.06	4.18
	N	68	68	68	68	68	68	68	68	68	68
	Std. Deviation	1.424	1.408	.775	.996	.658	.765	.863	1.172	1.196	.945

Table 3:ANOVA Table (F-statistic value on ANOVA)

			Sum of Squares	df	Mean Square	F	Sig.
Q1 * Scenario	Between Groups (Combined)		5.650	2	2.825	1.411	.251
	Within Groups		130.159	65	2.002		
	Total		135.809	67			
Q2 * Scenario	Between Groups (Combined)		26.142	2	13.071	7.961	.001
	Within Groups		106.725	65	1.642		
	Total		132.868	67			
Q3 * Scenario	Between Groups (Combined)		1.737	2	.869	1.466	.238
	Within Groups		38.498	65	.592		
	Total		40.235	67			
Q4 * Scenario	Between Groups (Combined)		6.169	2	3.085	3.322	.042
	Within Groups		60.346	65	.928		
	Total		66.515	67			
Q5 * Scenario	Between Groups (Combined)		.754	2	.377	.867	.425
	Within Groups		28.246	65	.435		
	Total		29.000	67			

Q6 * Scenario	Between Groups Within Groups Total	(Combined)	.003 39.233 39.235	2 65 67	.001 .604	.002	.998
Q7 * Scenario	Between Groups Within Groups Total	(Combined)	4.802 45.140 49.941	2 65 67	2.401 .694	3.457	.037
Q8 * Scenario	Between Groups Within Groups Total	(Combined)	.483 91.576 92.059	2 65 67	.241 1.409	.171	.843
Q9 * Scenario	Between Groups Within Groups Total	(Combined)	8.496 87.269 95.765	2 65 67	4.248 1.343	3.164	.049
Q10 * Scenario	Between Groups Within Groups Total	(Combined)	.740 59.142 59.882	2 65 67	.370 .910	.407	.668

INTERNAL AUDIT CHARACTERISTICS AND QUALITY OF ACCOUNTING INFORMATION IN NIGERIA

OGUNDANA, Oyebisi
OJEKA, Stephen;
OJUA, Michael
NWAZE, Chukwu

Department of Accounting
Covenant University,
Ota-Ogun State

ABSTRACT

The basic goal of Accounting is to provide enabling accounting information for reliable decision-making. The quality level of this accounting information comes from the company's governance practices, thereby emphasizing the importance of corporate governance in companies. Recently, following the financial crises resulting in accounting scandals, attention has been moving towards Internal Audit Function as an important factor in the structure of Corporate Governance. This paper therefore examined the extent of the relationship between internal audit function and the quality of accounting information of companies. The study adopted the Survey research design. The research instrument employed was Questionnaire which was administered to internal auditors of the "Big Four". Linear regression analysis was employed in the analysis of the data collected with the use of Statistical Packages for Social Sciences (SPSS). The results revealed that there is a significant relationship between the internal audit characteristics and the quality of accounting information. It was recommended that in order to provide credibility to the financial statement, there should be a law in place mandating attachment of internal auditors report to the financial statement.

Key words: Accounting quality, accounting report, corporate governance, fraud, internal auditing

1.0 INTRODUCTION

Recently, there has been considerable interest in the corporate governance practices of modern corporations, particularly since the high profile collapse of a number of large U.S. firms such as Enron Corporation and WorldCom (Adedipe, 2004:56). These high profile collapses which involved accounting fraud unfortunately, had serious devastating effect on stakeholders in terms of losses in their investment (Ojeka, Iyoha & Obigbemi, 2014). These events also led to loss of hundreds of jobs most especially in the manufacturing sector as well as a drop in the prices of shares of most companies listed on the floor of Nigerian Stock Exchange (Ojeka, Iyoha & Obigbemi, 2014). This wave of accounting scandals that occurred both in the international and local financial community has raised many criticisms about the financial reporting quality (Agrawal & Chadha, 2005), Such that the trust which prior to now stakeholders particularly investors had on the credibility and the quality of financial report presented by the management of companies could no longer be sustained as such reports were regarded as misleading and false. As a result of these various financial scandals, there is the need for the accounting profession to regain investors' confidence in financial reporting quality and the need for a quality financial report to meet expectations of current and potential investors. This has thereby given rise at the international level to the [U.S. federal government](#) passing the [Sarbanes-Oxley Act](#) in 2002 intending to restore public confidence in corporate governance. Likewise, in a bid to also achieve this same objective of restoring confidence in investors, the Nigerian Code of Corporate Governance was overhauled by the Securities and Exchange Commission in 2011 (Ojeka, Iyoha & Obigbemi, 2014).

Generally, the concept of corporate governance relates to the relationship between a company's management, board of directors, shareholders and other stakeholders. Good corporate governance entails efficient management of resources and provision of responsible leadership; it requires the provision of timely and quality information and the enforcement of sanction for breaches in ethical standard, regulations and Code of conduct (Ogbeche, 2006: 2). Suffice it to say that the whole essence of corporate governance is to ensure transparency, investor protection, full disclosure of executive action and corporate activities to stakeholders, assurance of

performance related executive compensation and full disclosure of executive compensation (Myers, 1997: 149). The corporate governance system comprises four cornerstones which are: Management, External auditor, Audit committee, and Internal auditor (IA) (Gramling, Maletta, Scheneide & Church, 2004; Prawitt, Smith & Wood, 2009). In recent years and following the financial crises, the focus of attention has been moving towards Internal Audit Function as an important factor in the structure of Corporate Governance (Al-Shetwi1, Ramadili, Chowdury & Sori, 2011; Coram, Ferguson & Moroney, 2008). The role of the internal audit function include: monitoring, assessing and analyzing organizational risk and controls; reviewing and confirming information and compliance with policies, procedures and controls.

The main interest of this paper therefore is on governance mechanism that can influence the quality of financial accounting report/information with particular interest on the internal audit function. The quality of accounting information is decomposed into three characteristics which are reliability, relevance and understandability. This paper is divided into five (5) sections, section one (1) is the introduction, section 2 is the review of relevant literatures, section three (3) is the methodology adopted, section four (4) is the analysis and interpretation of data collected with the use of statistical techniques while section five concludes the paper and includes recommendation.

2.0 LITERATURE REVIEW

2.1 Concept of internal audit and financial accounting information

In recent years and following the financial crises, the focus of attention has been moving towards Internal Audit Function as an important factor in the structure of Corporate Governance (Al-Shetwi1, Ramadili, Chowdury & Sori, 2011; Coram, Ferguson & Moroney, 2008). Internal auditing is a catalyst for improving an organization's governance, risk management and management controls by providing insight and recommendations based on analyses and assessments of data and business [processes](#). According to IIA, the objective of Internal Auditing is

an independent, objective assurance and consulting activity designed to add value and improve an organization's operations. It helps an organization accomplish its objectives by bringing a systematic,

disciplined approach to evaluate and improve the effectiveness of risk management, control and governance processes (IIA 2009:2).

Unegbu & Obi (2007) defined internal audit as part of the internal control system established by management of an organization for the purpose of ensuring strict adherence to stated work procedures, as well as serve as an aid to management. Internal auditing is an independent, objective [assurance](#) and [consulting](#) activity designed to add value and improve an organization's operations. It helps an organization accomplish its objectives by bringing a systematic, disciplined approach to evaluate and improve the [effectiveness](#) of [risk management](#), [control](#), and [governance](#) processes In the words of Unegbu & Obi (2007) Internal audit measures, analysis and evaluates the efficiency and effectiveness of other controls established by management in other to bring about smooth administration, control cost minimization, ensure capacity utilization and maximum benefit derivation. Vos (1997) opined that the objective of internal auditor is to evaluate effectiveness of financial and operating control, confirm compliance with company's policies and procedures, protect assets, and verify the accuracy of internal and external reports. The responsibility of the internal auditor is to reveal how well the accounting system works and also evaluate the effectiveness and efficiency of many organizations in the organization (Tracey, 1994).

IASB (2010) states that the main objective of financial reporting is to provide information that is useful to investors, creditors, and others in making investment, credit, and similar resource allocation decisions. There are two (2) main qualitative characteristics of financial accounting information, they are: Relevance and Faithful representation. Information is said to be relevant when a change in the information would affect the decisions of users of such information while faithful representation implies that information reflects the real world economic phenomena that it purports to represent. For financial information to be of good quality, it must be relevant, reliable, timely, understandable, faithful representation, comparable and verifiable.

Figure 1: Characteristics of financial statement used in making economic decision

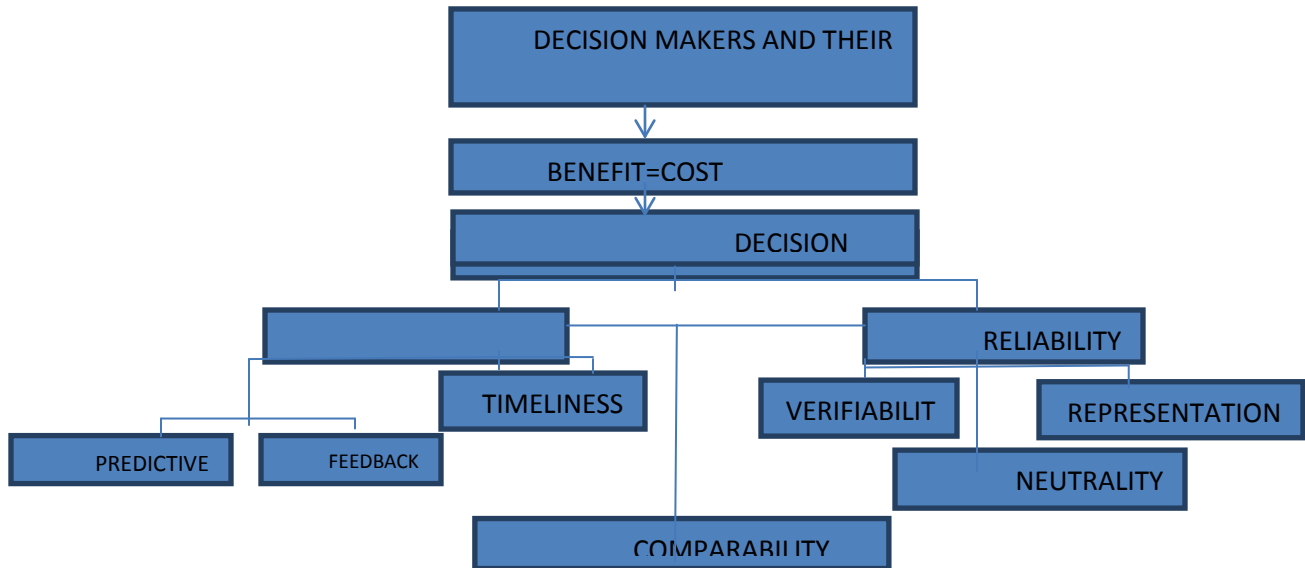

SOURCE: (FASB, 1980)

2.2 Internal audit function and quality of accounting information

Internal auditing activity as it relates to [corporate governance](#) has in the past been generally informal, accomplished primarily through participation in meetings and discussions with members of the Board of Directors but today, a primary focus area of internal auditing as it relates to corporate governance is helping the Audit Committee of the Board of Directors perform its responsibilities effectively. The internal audit function is an important function within an organization that has been shown to add value (Carey, Simnett & Tanewski, 2000; Goodwin & Kent, 2004; Carcello, Hermanson & Raghunandan, 2005) and reduce detected errors by external auditors (Wallace & Kreutzfeldt, 1991) and it is considered an important governance tool to protect corporations from internal criminal behaviour (Nestor, 2004) thereby improving the quality of the financial accounting information of companies.

Over the years, researches have shown that internal auditing function has a significant impact on financial reporting quality especially in the areas of preventing and detecting fraud (Church, Mcmillian & Schneider, 2001 ; Coram, P., Ferguson, C. and Moroney, R. 2008). Internal auditing plays a

very important role in corporate financial reporting; one of such areas where they play this important role is in the area of prevention and detection of fraudulent financial reporting. Investors with easy access to the internal audit function reports have greater confidence in the reports than those without access (Archambeault, Dezolt, & Holt, 2009; James, 2003). Similarly, evidence has shown that Internal audit function plays an important role in completing the financial statement audit (Zain, Subramaniam, & Stewart, 2006) imploring that internal audit function has an effective role in improving the audit quality and in turn financial reporting quality (Al-Shetwi¹, Ramadili, Chowdury and Sori, 2011).

A study carried out by Al-Shetwi¹, Ramadili, Chowdury and Sori, (2011) showed that there is no significant contribution between Internal audit function and financial accounting quality. The findings from this research study showed that the weak/no association between internal audit function and quality of accounting information might be due to the combined factors of an inadequate system as well as poor corporate governance. Another research study carried out by Coram et al. (2008) showed that organizations with an internal audit function are more likely than those without such functions to detect and self- report fraud. The findings of the study suggests that an internal audit function adds value to an organization through an improvement of the control and monitoring environment to enable the detection and self-report fraud thereby bringing about an increase in the accuracy of the accounting information disclosed. Consistent with the findings of Coram et al. (2008) is Nubbigh & Mamoghli (2010), who carried out a research on Internal audit characteristics and financial reporting quality. Internal audit characteristics was measured with internal auditor competence, internal controls weaknesses and procedures put in place to improve internal audit quality; while quality of financial reporting was estimated by earnings management. The result of the study showed that internal auditor competence, internal control weaknesses and procedures put in place to improve internal audit quality all have an impact on earnings management which is quality of financial reporting.

As a result of this inconsistency in the opinions of various authors with respect to the extent to the relationship between internal audit function and quality of accounting information, as well as going by the inadequacy of substantial literature in this area, the underlisted question is proposed for an empirical investigation

H₁: There is a significant relationship between internal audit function and quality of accounting information.

2.3 Internal audit characteristics and quality of accounting information

Al-Shetwii, et al. (2011), argued that the impact of Internal Audit Function on Financial Reporting Quality is a function of three factors, namely: the proficiency/competence of Internal Audit staff, Internal Auditors' independence, and Internal Auditors work performance. Ebrahim, Abdullah and Fauziah (2014) examined four factors of internal audit function which are: qualification of the audit department, size of the audit department, qualifications of the chief audit executive and experience of the audit department. In this study, internal audit comprises two factors namely: Competence and Independence.

2.4 Competence of the internal auditor and quality of accounting information

The first characteristic of internal auditor to be examined is competence and its relationship with quality of accounting information. According to Arens, Elder & Beasley (2012), "competence can be said to be the knowledge and skills necessary to accomplish tasks that define an individual's job". Competence therefore refers to the ability of an individual to perform a job or task properly with the application of a set of defined knowledge, skills, and behavior.

In a study carried out by Prawitt et al (2009), the relationship between internal audit quality (internal auditor's experience and internal auditor's qualification) and earnings management was examined. The study employed ordinary least square regression to test the relationship between the independent and dependent variables. The result revealed that staffs that are presumed competent can easily identify internal control weaknesses, and being employees of the company they know more about the structure and system in the company while in another study by DeZoort (1998), internal audit staff who are inexperienced and non-knowledgeable may find it difficult to detect areas of fraud in the internal control process which may lead to the production and publication of fraudulent financial report thereby bringing about poor quality of financial accounting information which may mislead stakeholders in the cause of making decisions. Further, an internal auditor is more familiar with the firm's structure and accounting information system than an external auditor being a member of staff of the organization, and this enhances an internal auditor's experience regarding the potential areas

of fraud thereby emphasizing the role of the internal auditor in the production of quality financial accounting information.

Similarly, Nelli (2014) examined the influence of internal auditor competence and independence on the quality of financial reporting by municipal/provincial government. The study was conducted and data elicited through the administration of questionnaire to the internal auditors of municipal/provincial governments. The result of the study showed that the competence of the internal auditor primarily affects the quality of financial reporting on city government and the provincial government. There are insufficient studies that examine the relationship between the quality of accounting information and competence of the internal auditor. As such, this current study seeks to examine the extent of the relationship between the internal auditor's competence and the quality of financial reporting. Therefore, the underlisted hypothesis was formulated to be tested:

H₂: There is a significant relationship between the competence of internal auditors and quality of accounting information.

2.5 Independence of internal auditors and quality of accounting information

Independence is a mental attitude that cannot be influenced nor controlled and does not involve reliance on the other party (Mulyadi, 2008). A study carried out by Payamta (2006) revealed that internal auditor's independence does affect the quality of financial reporting. Auditor independence is commonly referred to as the cornerstone of the [auditing](#) profession since it is the foundation of the public's trust in the [accounting](#) profession. Unfortunately, since the emergence of the various high profile cases of fraud, there has been a negative perception of the auditors' independence. Independence on the part of internal auditors is such that should enable staff of the internal audit to report all material cases they detect without any fear even if they disclose the faults of management itself.

Al-Shetwi et al. (2011) examined the impact of internal audit function on financial reporting quality of all Saudi companies listed in the Saudi stock exchange in 2009, excluding banks. Secondary and primary information was gathered through a matched survey and interview of both internal and external auditors. The findings showed that there is a weak relationship between the internal auditor's independence and quality of accounting information. In another study conducted by Adebayo (2011), on the impact

of auditor's independence on the credibility of financial statement in Nigeria, the study concluded based on the findings that there is a positive relationship between independence of an auditor and the credibility of financial statement. The data used for the study were collected from both primary and secondary sources. These data were equally analyzed using tables and simple percentages while the hypotheses generated were tested with the use of chi-square. The result of the test showed that auditor's independence affects the credibility of financial statement. There is no sufficient studies/literature with respect to the relationship between the internal auditor's independence and quality of accounting information. This therefore served as a basis for formulating the underlisted hypothesis:

H₃: There is a significant relationship between the independence of the internal auditors and quality of accounting information.

2.6 Agency Theory

The theory adopted for the purpose of this research study is the agency theory. Agency theory provides the framework for the evaluation of the relationship between the various parties in an organization. An agency relationship arises when one or more principals engage another person as their agent to perform their service on their behalf. In order to perform this service, there must be delegation of some decision making authority to the agent. Such delegation would require the agent placing trust in the principal. But as a result of the breach in trust placed in management, there is the need for an internal auditor who would checkmate and report to the board, the activities of management. This therefore introduces the concept of internal auditors as agents of principals. The internal auditor reports to the board of directors or its audit committee and is charged with monitoring the activities of the organization to ensure compliance with procedures and to likewise ensure that management is indeed acting in accordance with the laid down policies established by the board of directors.

3.0 Research Methodology

The survey research method was employed in this study. The choice for the survey method lies in the fact that it focuses on obtaining subjective opinion of respondents and aims at drawing an accurate assessment of the entire population by studying samples derived from the population usually in the form of questionnaire (Osuala, 2005). The primary data was used as a

source of data. The primary data was obtained from the group of respondents through a properly constructed questionnaire. The questionnaire was constructed using a five-point and Likert scale. The questionnaire was divided into three sections, Section's A, B and C were on questions pertaining to the three (3) hypotheses while Section D comprises personal information of the respondents.

For the purpose of this study, the target audience is the internal auditors. A total of 60 copies of the questionnaire were administered to internal auditors of the "big four" which are Delloitte, KPMG, PricewaterCoopers and Enest and young. The rationale behind this is as a result of the fact that they (big four) are representative of the accounting firms in Nigeria; their clients are spread across different sectors of the Nigerian economy; they control the market and have a functional internal audit department with highly skilled and well trained professional internal auditors. A total of 51 was received from the various respondents.

The data collected were analysed with the use of both descriptive and inferential statistics. The hypotheses formulated for this study were tested with the use of statistical parametric tools known as Regression analysis. This rational behind using regression analysis is to enable the researcher determine the extent of the relationship between the independent variable (internal audit characteristics) and dependent variable (quality of accounting information).

3.1 Hypotheses

RH₁: There is a significant relationship between the internal audit function and the quality of accounting information

RH₁: There is a significant relationship between the competence of the internal auditor and quality of accounting information

RH₁: There is a significant relationship between the independence of the internal auditor and the quality of accounting information.

3.2 Model Specification

$$Y = f(x_1, x_2, x_3) \dots \dots \dots (1)$$

$$Y = \beta_0 + \beta_1 x_1 + \beta_2 x_2 + \beta_3 x_3 + \mu \dots \dots \dots (2)$$

Where:

X= Independent variable = Internal Audit Characteristics

x_1 = Independence

x_2 = Competence

Y= Dependent variable = Quality of Accounting Information

y_1 = Timeliness/Relevance

y_2 = Reliability

y_3 = Understandability

β_0 = Intercept

μ = Error term/Stochastic variable

4.0 Analysis and Interpretation of Data

This section contains an analysis of the hypotheses tested using regression analysis.

Objective 1: To determine the extent of the relationship that exists between the internal audit function and the quality of accounting information

4.1.1 Model Summary

Model	R	R Square	Adjusted R Square	Std. Error of the Estimate
1	.279 ^a	.078	.059	.842

a. Predictors: (Constant), internal audit function

4.1.2 Coefficients^a

Model		Unstandardized Coefficients		Standardized Coefficients	T	Sig.
		B	Std. Error	Beta		
1	(Constant)	1.998	1.118		1.787	.080
	Internal audit function	.112	.055	.279	2.030	.048

a. Dependent Variable: There is a significant relationship between the internal audit function and the quality of accounting information

4.1.1 Model Summary

Model	R	R Square	Adjusted R Square	Std. Error of the Estimate
1	.279 ^a	.078	.059	.842

4.1.3

ANOVA^b

Model		Sum of Squares	Df	Mean Square	F	Sig.
1	Regression	2.925	1	2.925	4.123	.048 ^a
	Residual	34.761	49	.709		
	Total	37.686	50			

a. Predictors: (Constant), internal audit function

b. Dependent Variable: There is a significant relationship between the internal audit function and the quality of accounting information

The table above (Table 4.1.2) depicts an assessment of statistical significance of the result. This is a test of the null hypothesis to enable the determination of whether or not the null hypothesis should be accepted or rejected. From the coefficient table, the significance value in this study is 0.048, which is lower than the cut-off of ($p < 0.05$). This therefore signifies that there is a significant relationship between the internal audit function and the quality of accounting information. From the table, the R value is .279, when expressed in percentage terms; it shows that this model explains 27.9% of the variance in the dependent variable being quality of accounting. That is to say, the remaining 72.1% variation in the dependent variable can be explained outside the independent variable by other factors.

Objective two: To ascertain the extent of the relationship that exists between the internal auditors' competence and the quality of accounting information

4.2.1 Summary

Model

Model	R	R Square	Adjusted R Square	Std. Error of the Estimate
1	.049 ^a	.002	-.018	1.128

a. Predictors: (Constant), Competence

4.2.2 ANOVA^b

Model		Sum of Squares	Df	Mean Square	F	Sig.
1	Regression	.151	1	.151	.118	.732 ^a
	Residual	62.359	49	1.273		
	Total	62.510	50			

a. Predictors: (Constant), Competence

b. Dependent Variable: There is a relationship between the internal auditor's competence and quality of accounting information

4.2.3 Coefficients^a

Model		Unstandardized Coefficients		Standardized Coefficients	T	Sig.
		B	Std. Error	Beta		
1	(Constant)	4.326	1.244		3.477	.001
	Competence	-.022	.064	-.049	-.344	.732

a. Dependent Variable: There is a relationship between the internal auditor's competence and quality of accounting information

The table above (Table 4.2.3) depicts an assessment of the statistical significance of the result. This is a test of the null hypothesis to enable the determination of whether or not the null hypothesis should be accepted or

rejected. The significance value in this study is 0.732, there by showing that there is no significant relationship between the internal auditors' competence and the quality of accounting information. From the table, the R value is .049, when expressed in percentage terms; it shows that this model explains 4.9% of the variance in the dependent variable being quality of accounting. That is to say, the remaining 95.1% variation in the dependent variable can be explained outside the independent variable by other factors.

Objective three: To investigate the extent of the relationship between the internal auditors' independence and quality of accounting information

4.3.1 Model Summary

Model	R	R Square	Adjusted R Square	Std. Error of the Estimate
1	.060 ^a	.004	-.017	1.005

a. Predictors: (Constant), independence

4.3.2 ANOVA^b

Model		Sum of Squares	Df	Mean Square	F	Sig.
1	Regression	.177	1	.177	.175	.678 ^a
	Residual	49.510	49	1.010		
	Total	49.686	50			

a. Predictors: (Constant), independence

b. Dependent Variable: There is a significance relationship between the independence of the internal auditor and the quality of accounting information

4.3.3 Coefficients^a

Model	Unstandardized Coefficients	Standardized Coefficients	T	Sig.

	B	Std. Error	Beta		
1 (Constant)	4.528	1.085		4.174	.000
Independence	-.028	.067	-.060	-.418	.678

a. Dependent Variable: There is a significance relationship between the independence of the internal auditor and the quality of accounting information

The table above (Table 4.3.2) depicts an assessment of the statistical significance of the result. This is a test of the null hypothesis to enable the determination of whether or not the null hypothesis should be accepted or rejected. The significance value in this study is 0.678, the model in this table is not statistically significant since the value in the model is higher than the cut-off of ($p < 0.05$). This therefore signifies that there is no significant relationship between the internal auditors' independence and the quality of accounting information. From the table, the R value is .060, when expressed in percentage terms; it shows that this model explains 6.0% of the variance in the dependent variable being quality of accounting. That is to say, the remaining 94.0% variation in the dependent variable can be explained outside the independent variable by other factors.

4.3 Discussion of findings

The main aim of this study is to determine the extent of the relationship between the internal audit characteristics and the quality of accounting information. This study engaged three objectives which are: To determine the extent of the relationship between the internal audit function and the quality of accounting information; to ascertain the extent of the relationship between the internal auditor's competence and quality of accounting information; to investigate the extent of the relationship between internal auditor's independence and the quality of accounting information.

Significant relationship between the internal audit function and the quality of accounting information

Hypothesis one states that "there is a significant relationship between the internal audit function and the quality of accounting information". To test this, Regression analysis was ran and as a result, the null hypothesis was rejected, while the alternate hypothesis which states that "there is a relationship between the internal audit function and quality of accounting

information. All though, there is a relationship between the two variables, the extent of the relationship is not very strong/significant.

This empirical finding is consistent with the result of a research carried out by Rahmatika (2014) where it was shown that “internal audit has a positive effect on the quality of financial reporting”

Significant relationship between the internal auditors’ competence and the quality of accounting information

Hypothesis two states that “there is a significant relationship between the internal auditors’ competence level and the quality of accounting information”. To test this, Regression analysis was ran and as a result, the null hypothesis was rejected, while the alternate hypothesis which states that “there is significant relationship between the internal auditor’s competence level and quality of accounting information”. This empirical finding is consistent with the result of a research carried out by Al-Shetwi et al. (2011) which revealed that “internal auditors’ competence does not affect the quality of financial reporting on city government and the provincial government”

Significant relationship between the internal auditors’ independence and the quality of accounting information

Hypothesis one states that “there is a significant relationship between the internal auditors’ independence and the quality of accounting information”. To test this, Regression analysis was ran and as a result, the null hypothesis was accepted, while the alternate hypothesis which states that “there is no significant relationship between the internal auditor’s independence and quality of accounting information”. This empirical finding is consistent with the result of a research carried out by Al-Shetwi et al. (2011) who examined the impact of internal audit function on financial reporting quality of all Saudi companies listed in the Saudi stock exchange in 2009, excluding banks whose findings showed that there is a weak relationship between the internal auditor’s independence and quality of accounting information.

5.0 Conclusion and Recommendations

Accounting as the language of today's corporate governance structure, mainly reflects the effects and mechanism of corporate governance. The basic goal of Accounting is to provide enabling accounting information for reliable decision-making. The quality level of this accounting information comes from the company's governance practices, thereby emphasizing the importance of corporate governance in companies. Optimal decision making is therefore to a very large extent dependent on the quality of the financial accounting information/report presented to stakeholders at all levels. The role of the internal audit function as one of the corporate governance mechanism has become more prominent. When examined singularly, internal auditor's competence and independence do not contribute to the quality of accounting information, but when looked at collectively, there is a relationship between internal audit characteristics and quality of accounting information. This therefore implies that there are other forms of internal audit characteristics that affect the quality of accounting information. The underlisted Recommendations were made:

1. The office of the internal audit should be independent of management and the chief executive officer. If it is possible, the internal audit should not be directly under the chief executive officer/management.
2. To further provide assurance to the credibility of accounting information, internal auditors should be allowed by law to have a column in the financial statement where they can put together their report on the position and performance of the organization.
3. Accounting bodies and accounting regulatory authorities should come up with ways to improve independence and competence of the internal auditors.
4. Emphasis should be further placed on other characteristics of internal audit as it relates to quality of accounting information

REFERENCES

- Adebayo, O. (2011); An empirical analysis of the impact of auditors' independence on the credibility of financial statement in Nigeria. *Research Journal of Finance and Accounting*, 2(3): 82-98
- Adedipe, R. (2004); The dividend puzzle. *The Journal of Portfolio Management*, 12: 52-56.

- Agrawal, A. and Chadha, S. (2005); Corporate governance and accounting scandals. *Journal of Law and Economics*, 48(2): 371-406.
- Al-Shetwi1, M., Ramadili, S., Chowdury, T and Sori, S. (2011); Impact of internal audit function (IAF) on financial reporting quality (FRQ): Evidence from Saudi Arabia, *African Journal of Business Management*, 27(2): 11189-11198
- Archambeault, D., DeZoort, F. and Holt, T. (2008); The need for an internal auditor report to external stakeholders to improve governance transparency. *Accounting Horizons*, 22(4): 375-388
- Arens, Alvin A., Elder, Randa J; Beasley, Mark S, (2010); *Auditing and assurance services: An Integrated Approach*, (13th Ed), Pearson Prentice Hall Inc; New York.
- Bushman, R. and Smith, A. (2003); Transparency, financial accounting information and corporate governance. FRBNY Economic Policy Review. Retrieved on 10th January, 2015
<http://www.ukessays.co.uk/essays/accounting/corporate-governance-and-accounting-information-quality.php#ixzz3OQMoxjK3>
- Carcello, J., Hermanson, D. and Raghunandan, K. (2005); Changes in internal auditing during the time of the major US accounting scandals. *International Journal of Auditing*, 9: 117-127
- Carey, P., Simnett, R. and Tanewski, G. (2000); Voluntary demand for internal and external auditing by family businesses. *Auditing: A Journal of Practice and Theory*, 19
- Church, B., McMillan, J. and Schneider, A. (2001); Factors affecting internal auditor's consideration of fraudulent financial reporting during analytical procedures. *Auditing: A Journal of Practice and Theory*, 65-80
- Coram, P., Ferguson, C. and Moroney, R. (2008); Internal audit, alternative internal audit structures and the level of misappropriation of assets fraud. *Journal of Accounting and Finance*, 48: 543–559
- DeZoort, F. (1998); An analysis of experience effects on audit committee members' oversight judgment. *Accounting, Organization and Society*, 23(1): 1-21
- Ebrahim, M., Abdullah, K. and Faudziah, H. (2014); The effect of internal audit and firm performance: A proposed research framework. *International Review of Management and Marketing*, 4(1): 34-41

- Goodwin-Stewart, J. and Kent, P. (2006); The use of internal audit by Australian companies, *Managerial Auditing Journal*, 21 (1/2), 81
- Gramling, A., Maletta, M., Schneider, A. and Church, B. (2004); The role of the internal audit function in corporate governance. *Journal of Accounting Literature*, 23: 194-244.
- Holt, T., and DeZoort, T. (2009); The effects of internal audit report disclosure on investor confidence and investment decisions. *International Journal of Auditing*, 13: 61-77.
- Mulyadi, B. (2008); *Auditing*. Salemba Empat: Jakarta
- Myers, J. (1997); Determinants of corporate borrowing. *Journal of Financial Economic*, 5 (5) 147-175
- Novyarni, N. (2014); Influence of internal auditor competence and independence on the quality of financial reporting by municipal/provincial government. *International Journal of Economics, Commerce and Management*, 2(10): 1-14
- Ogbeche, G. (2006); Environmental dynamism, capital structure and performance: A theoretical integration and empirical test. *Strategic Management Journal*, 12:1-15
- Ojeka, S., Iyoha, F. and Obigbemi, I. (2014); Effectiveness of audit committee and firm performance in Nigeira: An empirical analysis. *Journal of Accounting and Auditing: Research and Practice*, 1-12
- Payamta. M. (2006); Effect of auditor quality, auditor independence and financial reporting quality audit terhadap opinion. *Journal of Business and Management*, 6(1).
- Prawitt, D., Smith, J. and Wood, D. (2009); Internal audit quality and earnings management. *The Accounting Review*, 84(4): 1255-1280
- Rahmatika, D. (2014); The impact of internal audit function effectiveness on quality of financial reporting and its implications on good governance Government research on Local Government Indonesia. *Research Journal of Finance and Accounting*, 5(18):
- Statement of Financial Accounting concept No. 2 (1980); Qualitative characteristics of accounting information. Connecticut: Financial Accounting Foundation
- The Institute of Internal Auditors (IIA) (2008); International standards for the professional practice of internal auditing. October: The Institute of Internal auditors.
- Tracey, J. (1994); *Fundamentals of financial accounting*. John Curly and Sons Inc.: New York

- Unegbu, A. and Obi, B. (2007); *Auditing*. Hipuks Additional Press: Enugu
- Vos, P. (1987); *Auditing practice*. Macdonald and Evans Press Limited: London
- Zain, M. Subramaniam, N. and Stewart, J. (2006); Internal auditors' assessment of their contribution to the financial statements audit: the relation with audit committee and internal audit function characteristics. *International Journal of Auditing*, 10: 1–18.

CORPORATE GOVERNANCE AND AUDIT QUALITY

**Dr Okaro, S.C.
Dr Okafor, G.O.,
&
Prof Okoye, E. I.,**

Nnamdi Azikiwe University,
Awka,
Department of Accountancy.

ABSTRACT

This paper evaluates the practice of auditing in Nigeria in order to determine empirically corporate governance factors that affect audit quality some of which if addressed will help in stemming the tide of audit failures. The paper specifically investigates whether audit committee effectiveness and board effectiveness have any significant effect on audit quality. The study made use of secondary data from the annual reports of a sample of 104 companies randomly selected from a population of 134 non-bank companies listed in the Nigerian Stock Exchange. However, only 84 companies with sufficient data were used. Banks were excluded from the study because of the special regulations guiding their operations. The dependent variable of the study is audit quality while independent variables are board effectiveness (Board size, Board independence, Board diligence) and audit committee effectiveness (Audit committee size, Audit Committee diligence and audit committee independence). The hypotheses of study were analysed using binary logistic regression model. The major findings of this paper are that small board size and greater board diligence impact positively on audit quality. The policy implication of the findings is that some corporate governance practices do have positive effects on audit quality and should be made mandatory.

Key words: Audit failure, Audit Quality, Corporate governance, Board, Audit Committee

INTRODUCTION

Attempts to solve the problem of audit failures have taken the front burner and cuts across jurisdictions. The genesis of current global attempts to fix audit failures, arguably, can be traced to Enron debacle in the United States of America and resulted in the promulgation of Sarbanes-Oxley Act in 2002 with dire consequences for the accounting profession in that country. In Europe, a lot of options to strengthen the conduct of audit is currently being debated by various stakeholder groups and include freeing up audit competition, mandatory rotation of auditors, audit tendering and joint audits (Nonnenmacher, 2011). This is happening at a time that uniform global financial reporting standard (IFRS) is gaining currency (Okpala, 2012). Jurisdictions attempt to take into cognizance their peculiar socio-economic, political and cultural environments in the search for audit quality (Okike, 2004).

Studies on the issue of corporate governance factors in audit quality in Nigeria is still evolving (Adeyemi & Fagbemi, 2010). These include studies on board diligence, audit committee diligence, audit committee size, board independence, audit committee independence and board size. This gives room for more studies in this area. Some of the studies are industry specific (Samuel, 2012; Olayiwola, 2010; Akinyomi, 2012; Otusanya, 2010; Okoye & Akenbor, 2010) implying that their findings cannot be generalized. Furthermore, the findings of some of the studies were in direct conflict with the results of some similar studies by other researchers. A good example is the issue of audit firm tenure or mandatory rotation of auditors. While Ebimobowei and Keretu (2011) conclude that mandatory rotation of auditors is desirable and has a salutary effect on audit quality. Mgbame, Eragbhe and Osazuwa (2012) did not see any significant effect of mandatory rotation of auditors on audit quality. This study intends to look at how some corporate governance factors affect audit quality with a view to adding to the scanty literature in this area in Nigeria.

The general objective of this study is to evaluate the practice of auditing in Nigeria in order to determine empirically some corporate governance factors that affect audit quality in the Nigerian environment. The specific objectives are as follows:

- i. To investigate whether audit committee effectiveness as measured by independence, size and diligence has any significant effect on audit quality.
- ii. To determine whether board of directors' effectiveness as measured by board independence, size, and diligence has a significant effect on audit quality.

The following research questions were formulated to achieve the objectives of this study:

- i. What is the relationship between audit committee effectiveness as measured by audit committee independence, audit committee size, audit committee diligence and audit quality?
- ii. How would board effectiveness as measured by board size, board independence and board diligence affect audit Quality?

The following hypotheses were formulated and tested in the course of the study

(1a) Ho: Audit committee size does not significantly affect audit quality.

(1b) Ho: Audit committee diligence has no significant effect on audit quality

(1c) Ho: Audit committee independence has no significant effect on audit quality.

(2a) Ho: Board size does not have a significant effect on audit quality.

(2b) Ho: Board diligence is not significantly related to audit quality

(2c) Ho: Board independence has no significant effect on audit quality.

This study is expected to equip the regulatory authorities with better knowledge of the corporate governance factors impinging on audit quality in Nigeria which will guide future regulatory interventions in solving the vexed issue of audit failures in Nigeria. Also, members of the accounting profession, company management and indeed the members of the public will also benefit from a greater insight into some corporate governance factors that affect audit quality in Nigeria.

This study covers the search for audit quality in Nigeria with a view to stemming the tide of audit failure. The geographical scope of this study is Nigeria. Secondary data were sourced from a sample of 104 firms which

were randomly selected from a population of 136 non-financial firms quoted on the Nigerian Stock Exchange. However, only 84 firms were used because of the problem of availability of relevant data. Financial companies were excluded because they are guided by special regulations.

REVIEW OF RELATED LITERATURE

Conceptual Framework

Audit Quality

An audit must be of sufficient quality if audit failures will be reduced to the barest minimum. According to Tackett, Wolf and Claypool (2006), auditing failure occurs when management grossly misrepresents their financial statements and auditors through negligence or incompetence fail to discover and report the misrepresentation. A classical definition of audit quality is that it is the market-assessed joint probability that a given auditor will both: (i) identify a breach in the client company accounting system and (ii) report that breach, that is that the auditor has both the technical competence to detect any material errors during the audit process, and the independence to ensure that material errors and omissions are corrected or disclosed in the auditor's report (De-Angelo, 1981).

The following propositions about audit quality, among others, have been made in order to further clarify the concept:

- i. How to define and measure audit quality is still not known
- ii. Zero risk cannot be the goal of audit quality
- iii. Audit quality as an outcome cannot be completely divorced from reporting quality
- iv. Any definition of audit quality must take cognizance of the fact that audit is a professional service
- v. Audit quality is uncertain and idiosyncratic

Audit failure from the perspective of the auditor can be grouped into two. Calibration failure refers to the variance of planned assurance from targeted assurance. Execution failure, on the other hand, refers to the variance of achieved assurance from planned assurance. The primary cause of execution failure are misdiagnosis and inappropriate treatment of risk. The quality of auditing is inherent in the nature and execution of the activities that diagnose and treat risk in the audit process (Knechel, 2009)

This study used the presence of any of the big 4 Audit firms in an audit as evidence of audit quality and vice versa.

Audit Committees

Many characteristics have been canvassed as making for an effective audit Committee (Lin, Xiao, & Tang, 2008). These include independence, large size and frequency of meetings (Karamanou & Vafeas, 2005). Other studies also emphasize the multiple directorships of audit committee members, yet other studies premise audit committee effectiveness on its composition, size, members' qualifications and actual audit committee operations. One study tested the following audit committee characteristics; size, the ratio of audit committee members with accounting financial expertise, average tenure of audit committee members and average number of outside audit committee positions held by audit committee members (Kiatapiwat, 2010).

Audit committee members should be independent of an organisation's management to perform the oversight role and protect shareholders interests (Al-lehaidan, 2006). However, independence is not enough (Sori, Ali, Hamid, & Evans, 2007). Anderson et al. (2003), however did not find any relationship between audit committee independence and information content of earnings. Lack of adequate knowledge and relevant experience causes inability and failure of audit committee members to understand their roles and responsibilities in the firm (Karbhari & Mohiuddin, 2010; Ashikin, Saat, Karbhari, Xiao, & Heravi, 2012).

It is debatable whether audit committee size is an influential factor in its effective functioning. While some argue that it does (Ahmad-zaluki, Nordin, & Hussin, 2009; Al-matari & Al-Swidi, 2012), others are not so persuaded arguing that a large audit committee may in fact be counterproductive as more members in audit committee may lead to unnecessary debates resulting in delayed decisions (Al-matari & Al-matari, 2012).

Members' diligence is extremely important in shouldering the responsibilities of the committee effectively and with integrity (Lifschutz & Jacobi, 2010; Ghafran, 2013). However, since diligence is extremely difficult to measure in practice, researchers usually use the frequency of audit committee meetings as a surrogate for diligence (Saleem & Alzoubi, 2012).

The Board and Corporate Governance

The four drivers of corporate governance are accountability, fairness, transparency and independence. An essential feature of the modern corporation is the divorce of ownership from management. This separation of ownership from control, however, implies a loss of effective control by shareholders over managerial decisions. The primary objective of corporate

governance is, therefore, to try and align managerial incentives with that of stakeholders so that managers work in the best interest of the stakeholders, (Nworji, Adebayo & David, 2011).

Board Effectiveness

Independence is a quality that can be possessed by individuals and is an essential component of professionalism and professional behavior. It refers to the avoidance of being unduly influenced by a vested interest and to being free from any constraints that would prevent a correct course of action being taken. It is an ability to “Stand Apart” from inappropriate influences and to be free of managerial capture, to be able to make the correct and uncontaminated decision on a given issue, (Campbell, 2011). Outside directors are generally believed to be more effective in monitoring management and enhancing financial reporting quality. Researches have, however, shown that it is not ideal to have only outside directors in the board (He, Labelle, Piot, & Thornton, 2013). Board size is also likely to be related to board performance because adding more people to the board enhances the knowledge base (Azim, 2012). However, very large boards are less flexible due to potential free riding, communication break downs and inefficiencies (Boo & Sharma, 2008). Caution is therefore required in choosing the optimum size of a board. Frequency of board meetings is usually taken as a proxy for board diligence (Kent & Stewart, 2008).

The Board and Audit Quality

The board of directors typically collaborates with management in selecting the external auditor, often subject to shareholder ratification. The board usually reviews the overall planned audit scope and fee thus indirectly influencing audit quality. The board’s commitment to vigilant oversight may signal to both management and the auditor that the expectations placed on the audit firm are very high. If that is the case, the auditors will strive to do high quality audit so as not to do disappoint the directors (Soliman & Elsalam, 2012). Such situations will also minimize the “ games” auditors and managements sometimes play (Osei-afokwa, 2013; Akpomi, Amesi, & Harcourt, 2009).

Theoretical Framework – The Agency Theory

Agency theory presupposes that shareholders require protection because management (agents) may not always act in the best interest of absentee

owners,(Jensen & Meckling, 1976). To deal with this, the Board assumes an oversight role that typically involves monitoring the Chief executives and other top executives and monitoring internal control over financial reporting,(Wan- Hussin & Haji-Abdullah, 2009). Debt holders are also another group with interests in deriving maximum utility from the actions of management. In addition to investing in control systems, owners and agents have incentives to invest in various information systems to reduce agency costs associated with information asymmetry. Two agency problems exist in an information asymmetry situation: adverse selection where the principal cannot determine if the agent is performing the work for which he/she is paid, and moral hazard where the principal is unsure as to whether the agent has performed their work to their ability (Arnold & Lange, 2004). All in all, agency theory places economic self-interest at the centre of theoretical expectations. Certain contractual relationships combined with information asymmetry indicate a corresponding demand for investment in control and monitoring mechanisms including independent Boards, effective audit committees and external audit, (Kalbers & Fogarty, 1998).

Research Methods

This study made use of secondary data. The 136 non-financial companies listed on the Nigerian Stock Exchange in 2012/13 year of the Exchange constituted the population of the study. The study applied random technique in selecting 104 companies determined using the Taro Yamani formula but however, used only 84 companies who had full data. Source of data was longitudinal data gathered from annual reports of selected quoted companies in Nigeria. The data collected included the companies' auditors, the number of times their boards met in the year and the number of executive directors in their boards. The Nigerian Stock Exchange 2012/2013 Fact Book was used in collecting secondary data and showed that 134 companies were listed on the main Board of the Exchange. This figure excluded Banks and Insurance companies because of the fact that they are subject to special regulations. The relevant annual reports are reports of companies with year ends covering 1st January 2012 to 31st December 2013. The reports were the latest available from the Exchange. The relevant data were extracted from the annual reports between June and July 2014

The statistical technique applied in this study was the binary logistic regression model used to test the relationships between audit quality as a

dependent variable and some board characteristics and audit committee characteristics as independent variables. The use of binary logistic regression model is justified since this is a situation where the dependent variable is binary (0 or 1) (Niemi, Kinnunen, Ojala, & Troberg, 2012).

Accordingly, the following econometric model in general form is thus specified for the study:

Dependent variable = $\beta + \sum\beta + \text{Independent Variables} + \sum\beta \text{ Control Variables} + \varepsilon$

Where β = Intercept of regression line and ε = error term.

Source: Adapted from (Wan-Hussin & Haji-Abdullah, 2009).

The dependent variable is audit quality and is measured by the likelihood that a sampled company employs the services of the big 4 audit firms in Nigeria. In the choice of the dependent variable, empirical support was found in (Velnampy, Sivathaasan, Tharanika, & Sinthuja, 2014). The big 4 audit firms in Nigeria are namely, Price Water House/Cooper (PWC), Ernst and Young (EY), Akintola Williams/Delliotte (AWD) and KPMG Professional group (KPMG). Accordingly, a dummy variable of 1 is used if a firm is audited by any of the big 4 audit firms otherwise a 0 value is assigned.

The study model was specified as follows:

Audit Quality = β Audit Tenure + β Director Share Ownership + β Financial Expertise of Audit Committee Chair + β Audit Committee Independence + β Audit Committee Diligence + β Board Size + β Board Independence + β Audit Committee Size + β Board Diligence + β Total Assets + β Return on Assets.

The independent variables for the model are: Board independence represented by proportion of non-executive directors in the board of a company. Board size is represented by the number of directors on the board. Audit tenure measured by the number of years an auditor has been with a company on a continuous basis, if greater than 10 we assign 1 else 0. The use of greater than 10 and otherwise 0 to measure length of audit tenure is informed by the SEC code of 2011 and CBN corporate governance code both of which recommend a maximum external audit tenure of 10 years. Board ownership is measured by proportion of equity shares owned by the directors of a company. Board diligence is measured by the number of annual meetings held by the directors annually. Similarly, audit committee

diligence is measured by the number of meetings held annually by members of the committee. Audit committee size is represented by the number of audit committee members. If the chairman of an audit committee is either a member of ICAN or ANAN we assign 1 otherwise 0. Audit committee independence is measured by the proportion of non- executive directors in the audit committee in relation to the total number of directors in the committee.

In line with similar studies, the study control for the following, firm size and return on assets.

The firm size is measured by the Natural logarithm of total assets while Return on Assets is = total annual earnings of the sample firm/total assets (Mgbame et al., 2012). Testing the two variables is not one of the study goals. They were used to control the influence of firm specific financial factors.

Also to make the research manageable, the study did not review literature on, nor hypothesised on board ownership, financial expertise of audit committee chair and audit tenure although they appeared in the model as X3, X4 and X1 in the model respectively.

Model Confirmation

Table 1: Omnibus Tests of Model Coefficients (Output of SPSS 17)

		Chi-square	Df	Sig.
	Step	26.918	11	.005
Step	Block	26.918	11	.005
1	Model	26.918	11	.005

A Chi square of 26.918 at 0.005level of significance (approximately1%) shows that the model is dependable and reliable.

Table 2: Likelihood Test (Output of SPSS 17).

Step	-2 Log likelihood	Cox & Snell R Square	Nagelkerke R Square
1	82.577 ^a	.274	.376

a. Estimation terminated at iteration number 6 because parameter estimates changed by less than 0.001.

The Nagelkerke R Square is 0.376. This means that 37.6% of audit quality is explained by the independent variables.

Table 3: Classification Table (Output of SPSS 17)

Classification Table

	Observed		Predicted		
			Audit Quality		Percentage Correct
			Otherwise	Audited by big four Firms	
Step 1	Audit Quality	Otherwise Audited by big four Firms	16	14	53.3
			10	44	81.5
	Overall Percentage				71.4

a. The cut value is .500

Table 3 shows that the model classified the data accurately 53.3% of the time (16 out of 30 audited by the non- big 4) in respect of companies audited by the non- big four. In a similar vein, for the companies audited by the big four the model classified the data accurately 81.5% of the time (44 out of 54 audited by the big four).Overall on a weighted average basis the model classified the data correctly 71.4% of the time which is greater than the cut off value of 50%. Also the value of 53.3% correct classification for non- big four audited companies is greater than the cut off value of 50%. The study concludes that the result of the test shows that the model is dependable and reliable and can be relied upon in making inferences.

DATA PRESENTATION AND ANALYSIS

Summary of Data for Test of Hypotheses One and Two

Table 4- Output of Regression Analysis (SPSS 17).

Variables in the Equation

	B	S.E.	Wald	Df	Sig.	Exp(B)
x1	-.006	.628	.000	1	.993	.994
x3	-.012	.013	.762	1	.383	.989
x4	.506	.572	.783	1	.376	1.659
x5	-.617	1.631	.143	1	.705	.539
x6	1.086	.545	3.969	1	.046	2.962
x7	.353	.345	1.043	1	.307	1.423
Step 1 ^a x8	-.406	.191	4.527	1	.033	.666
x9b	.283	.212	1.782	1	.182	1.327
x10	2.950	2.834	1.083	1	.298	19.105
x11	.242	.353	.469	1	.493	1.274
x12	.610	.288	4.476	1	.034	1.840
Constant	-8.494	4.098	4.296	1	.038	.000

a. Variable(s) entered on step 1: x1, x3, x4, x5, x6, x7, x8, x9b, x10, x11, x12.

Test of Hypotheses

Hypothesis 1a

Ho: Audit committee size does not significantly affect audit quality

From table 4 above, the relevant variable is X11. Also from the table Audit committee size is positively related audit quality (B coefficient= .242) but is not significant at 0.05 level (0.493).

Decision: Accept the null hypothesis and reject the alternative hypothesis that audit committee size significantly affects audit quality.

Hypothesis 1b

Ho: Audit committee diligence has no significant effect on audit quality.

From table 4 above the relevant variable is X7. Also from the table, Audit committee diligence is positively related to audit quality (B coefficient = .353) but is not significant at 0.05 level (.307).

Decision: Accept the null hypothesis and reject the alternative hypothesis that audit committee diligence has a significant effect on audit quality

Hypothesis 1c

Ho: Audit Committee Independence has no significant effect on audit quality. The relevant independent variable is X5 which was regressed against the dependent variable (audit quality). The table showed a negative relationship between Audit committee independence and audit quality (B coefficient = -.617). However, the relationship is not significant at 0.05 level (.617).

Decision: Accept the null hypothesis and reject the alternative hypothesis that audit committee independence has significant effect on audit quality.

Hypothesis 2a

Ho: Board size does not have any significant effect on audit quality

From table 4 above, the relevant independent variable is X8. This was regressed against audit quality as the dependent variable. The table shows that Board size has a negative effect on audit quality (B coefficient = -.406). The table also shows that this relationship is significant at 0.05 level (.033).

Decision: Reject the null hypothesis and do not reject the researcher's hypothesis that Board size has significant effect on audit quality.

Hypothesis 2b

Ho: Board diligence is not significantly related to audit quality

From table 4, the relevant independent variable is X12. This is regressed against audit quality as the dependent variable. The table showed a positive relationship between board independence and audit quality (B coefficient = .610). The table also showed that the relationship is significant at 0.05 level (.034).

Decision: Reject the null hypothesis and accept the researcher's hypothesis that Board diligence is significantly related to audit quality.

Hypothesis 2c

Ho: Board independence does not have any significant effect on audit quality.

From table 4 the relevant independent variable is X10. The table showed a positive relationship between Board independence and audit quality (B coefficient = 2.950). This is not significant at 0.05 level of confidence (.298). Decision: Accept the null hypothesis and reject the alternate hypotheses that Board independence has a significant effect on audit quality.

Discussion of Findings

The empirical analysis of this study provides interesting and revealing results and will be discussed under the following headings Audit Committees and Audit quality; Board of Directors and Audit quality.

Audit Committees and Audit Quality

Audit committee size was found to have a positive but insignificant effect on audit quality. A positive audit committee size and audit quality relationship has empirical support, (Saidin, 2007). However, there are also views that audit committee size may in fact be detrimental to audit quality (Al-matari & Al-matari, 2012). Audit committee diligence is proxied by the number of meetings held annually by audit committee members. The study documented a positive but insignificant relationship with audit quality. Many empirical studies lend credence to a positive relationship between audit quality and audit committee diligence (Song & Windram, 2000; Lifschutz & Jacobi, 2010). There are also empirical studies that document negative or not significant relationship between audit committee diligence and audit quality,(Haji-Abdullah, 2006). This study found negative but insignificant association between audit quality and audit committee independence. Many studies document positive association between audit committee independence and audit quality (Al-lehaidan, 2006; Adelopo, 2010). One study, however, documented a negative association between audit committee independence and audit quality in a situation where some executive officers of a company do not participate in audit committee meetings (Ashikin, et al., 2012)

Board Committees and Audit Quality

The study hypothesised that board size had an insignificant effect on audit quality. Empirical evidence supported this view. Other studies that confirmed this view or reported insignificant association between board size and audit quality include (Al-matari & Al-Swidi, 2012; Ibadin, 2012; Velnampy, et al., 2014). Other views support large board size being consistent with audit

quality (Lajmi & Gana, 2011). The study hypothesised that board diligence does not have significant effect on audit quality. The result was not consistent with the hypothesis. Other empirical works however find insignificant association between board diligence and audit quality (Lajmi & Gana, 2011). The SEC 2011 code requires boards to meet at once in a quarter and members of the board should attend at least 2/3 of the meetings. The study also hypothesised that board independence has an insignificant effect on audit quality. Our result showed a positive but not significant relationship. Many empirical studies record a positive and significant relationship between board independence and audit quality, (Enofe, Mgbame, Aderin, & Ehi-oshio, 2013; Soliman & Elsalam, 2012; Hassan, 2013). Other studies report a negative or insignificant relationship between board independence and audit quality (Matoussi & Gharbi, 2011; Ibadin, 2012; Hoseinbeglou, Masrori & Asadzadeh., 2013).

Conclusion

From the empirical examination of the hypotheses developed from the theoretical framework presented in this study, it was found that audit committee size has a positive effect on audit quality but the relationship was not significant. Audit committee diligence was positively related to audit quality although the relationship was not significant. Audit committee independence has a positive but insignificant effect on audit quality. Board size has a negative and significant effect on audit quality. Board diligence has a positive and significant effect on audit quality. Board independence has a positive but insignificant effect on audit quality.

The results of this study show that there is a fairly significant influence of corporate governance characteristics on audit quality. There is need to mandate corporate governance practices that affect positively audit quality in Nigeria. These include optimum board size and board diligence.

REFERENCES

Adelopo, I. (2010). The impact of corporate governance on auditor independence: A study of audit committees in UK listed companies, Doctoral thesis, University of De mont, De mont

- Adeyemi, S. B, & Fagbemi, T. O. (2010). Audit quality , corporate governance and firm characteristics in Nigeria. *International Journal of Business Management*, 5(5), 169–179.
- Ahmad-zaluki, N. A., Nordin, W., & Hussin, W. (2009). Corporate governance and the quality of financial information disclosure. *Accountants Today*, 1–7.
- Akinyomi, O. J. (2012). Examination of fraud in the Nigerian banking sector and its prevention. *Asian Journal of Management Research*, 3(1), 184–192.
- Akpomi, M. E., Amesi, J., & Harcourt, P. (2009). Behavioural constraints on practices of auditing in Nigeria. *Educational Research and Review*, 4(10), 465–469.
- Al-fayoumi, N., & Alexander, D. (2010). Ownership structure and earnings management in emerging Markets: The case of Jordan. *international research Journal of finance and Economics*, 38(38).
- Al-lehaidan, I. (2006). *Audit committee effectiveness: Australia and Saudi Arabia*, Doctoral thesis, University of Victoria, Victoria.
- Al-matari, E. M., & Al-Swidi, A. K. (2012). The impact of board characteristics on firm performance: evidence from nonfinancial listed companies in Kuwaiti stock exchange. *International Journal of Accounting and Financial Reporting*, 2(2), 310–332. doi:10.5296/ijaf.v2i2.2384
- Al-matari, Y. A., & Al-matari, E. M. (2012). Board of directors , audit committee characteristics and performance of Saudi Arabia listed companies. *International Review of Management and Marketing*, 2(4), 241–251.
- Anderson, K. L., Deli, D. N., Gillan, S. L., Anderson, K. L., Deli, D. N., & Gillan, S. L. (2003). *Boards of directors, audit committes, and the information content of earnings*. Working Paper, University of DelaWare.

- Arnold, B., & Lange, P. De. (2004). Enron: an examination of agency problems. *Critical Perspectives on Accounting*, 15, 751–765. doi:10.1016/j.cpa.2003.08.005
- Ashikin, N., Saat, M., Karbhari, Y., Xiao, J. Z., & Heravi, S. (2012). Factors affecting independent audit committee members 'effectiveness : The case of listed firms on Bursa Malaysia. *World Review of Business Research*, 2(3), 132–147.
- Azim, M. I. (2012). Corporate governance mechanisms and their impact on company performance: A structural equation model analysis. *Australian Journal of Management*, 37(3), 481–505. doi:10.1177/0312896212451032
- Boo, E., & Sharma, D. (2008). Effect of regulatory oversight on the association between internal governance characteristics audit fees. *Accounting and Finance*, 48, 51–71.
- Campbell, D. (2011). Independence as a concept in corporate governance. Retrieved July 26 from www.accaglobal.com/students
- De-Angelo, L. E. (1981). Auditor independence, low Balling, and disclosure regulation. *Journal of Accounting and Economics*, 3, 183–199.
- Ebimobowei, A., & Keretu, O. J. (2011). Mandatory Rotation of Auditors on audit quality, costs, and independence in South-South Nigeria. *International business management*, 5(3), 166– 172.
- Enofe, A. O., Mgbame, C., Aderin, A., & Ehi-oshio, O. U. (2013a). Determinants of audit quality in the Nigerian business environment. *Research journal of finance and Accounting*, 4(4), 36–44.
- Ghafran, C. M. (2013). *Audit committees and financial reporting quality*, Doctoral thesis, University of Sheffield, Sheffield

- Haji-Abdullah, N. M. (2006). The characteristics of audit committee and the quality of financial reporting in Malaysia. Retrieved December 31 from <http://ssrn.com/abstract>
- Hassan, S. U. (2013). Financial reporting quality: Does monitoring characteristics matter? An empirical analysis of Nigerian manufacturing sector . *The Business and Management Review*, 3(2), 147–161.
- He, L., Labelle, R., Piot, C., & Thornton, D. B. (2013) Board monitoring, audit committee effectiveness and financial reporting quality: Review and synthesis. Retrieved July 26 from <http://ssrn.com/abstract>
- Hoseinbeglou, S., Masrori, R., & Asadzadeh, A. (2013). The effect of corporate governance mechanisms on audit quality. *J. Basic. Appl. Sci Res.*, 3(1), 891–897.
- Ibadin, I. M. (2012). The association between selected corporate governance attributes, company attributes and timeliness of financial reporting in Nigeria. *Research Journal of Finance and Accounting*, 3(9), 137–145.
- Jensen, M. C., & Meckling, W. H. (1976). Theory of the Firm: Management behaviour, agency costs and ownership structure. *Journal of Financial Economics*, 3(October), 305–360.
- Kalbers, L. P., & Fogarty, T. J. (1998). Organizational and economic explanations of audit committee oversight. Working Paper, *Pittsburg State University*.
- Karamanou, I., & Vafeas, N. (2005). The Association between corporate boards , audit committees , and management earnings forecasts: An empirical analysis. *Journal of Accounting Research*, 43(3), 453–486. doi:10.1111/j.1475-679X.2005.00177.x
- Karbhari, Y., & Mohiuddin, M. (2010). Audit committee effectiveness: A critical literature review. *AIUB Journal of Business and Economics*, 9(1), 97–125.

- Kent, P., & Stewart, J. (2008). Corporate governance and disclosures on the transition to international financial reporting standards. *Accounting and Finance*, 48, 649–671.
- Kiatapiwat, W. (2010). Controlling shareholders, audit committee effectiveness, and earnings quality: The case of Thailand, Doctoral thesis, Maryland University, Maryland.
- Knechel, W.R.,(2009). Audit lessons from the economic crisis: Rethinking audit quality. *Inaugral Lecture* (pp. 1–20). Maastricht: Maastricht University.
- Lajmi, A., & Gana, M. (2011). Directors ' Board characteristics and audit quality: Evidence from Belgium. *Journal of Modern Accounting and Auditing*, 7(7), 668–679.
- Lifschutz, S., & Jacobi, A. (2010). Corporate governance characteristics and external Audit fees: A study of large public companies in Israel. *International Journal of Business and Management*, 5(3), 109–116.
- Lin, Z. J., Xiao, J. Z., & Tang, Q. (2008). The roles , responsibilities and characteristics of audit committee in China. *Accounting, Auditing and Accountability Journal*, 21(5), 721–751. doi:10.1108/09513570810872987
- Matoussi, H., & Gharbi, I. (2011). Board independence and corporate fraud: The case of Tunsian firms. Working Paper, University of Manouba.
- Mgbame, C. O., Eragbhe, E., & Osazuwa, P. N. (2012). Audit partner tenure and audit quality: An Empirical analysis. *European Journal of Business and Management*, 4(7), 154–163.
- Niemi, L., Kinnunen, J., Ojala, H., & Troberg, P. (2012). Drivers of voluntary audit in Finland: to be or not to be audited? *Accounting and Business Research*, 42(2), 169–196
- Nonnenmacher, R. (2011). Further EC proposals for reform of the audit market. Retrieved December 26 from kpmg.com/ifrs

- Nworji, I. D., Adebayo, O., & David, A. O. (2011). Corporate governance and Bank failure in Nigeria: Issues, challenges and opportunities. *Research Journal of Finance and Accounting*, 2(2), 27–44.
- Okike, E. (2004). Management of crisis: The Response of the auditing profession in Nigeria to the Challenge to its Legitimacy. *Accounting, Auditing and Accountability Journal*, 17(5), 705–730.
- Okoye, E., & Akenbor, C. (2010). Enhancing the effectiveness of audit committee in Nigerian manufacturing companies. *Journal of Policy and Development Studies*, 4(2), 117–127.
- Okpala, K. E. (2012). Adoption of IFRS and financial statements effects: The perceived implications on FDI and Nigeria economy. *Australian Journal of Business and Management Research*, 2(05), 76–83.
- Olayiwola, W. K. (2010). Practice and standard of corporate governance in the Nigerian banking industry. *International Journal of Economics*, 2(4), 178–189.
- Osaze, E. B. B. (2011). The specificities of value melt-down in the Nigerian Stock Exchange 2008-2010: Some parallax snaps. *Professorial Chair Lecture, University of Benin, Benin*
- Osei-afokwa, K. (2013). The Games Ghanaian auditors play with their reports. *International Journal of business and Management Tomorrow*, 3(1), 1–14.
- Otusanya, J. O. (2010). An investigation of corporate executive fraud by CEOs in the Nigerian banking industry. Working Paper, University of Lagos, Lagos
- Saleem, E., & Alzoubi, S. (2012). The effectiveness of corporate governance mechanisms on constraining earning management: Literature review and proposed framework. *International Journal of Global Business*, 5(1), 17–35.

- Samuel, G. (2012). Attributes of audit committee members and quality of financial reporting in banks in Nigeria. Doctoral thesis, Ahmadu Bello University, Zaria.
- Soliman, M. M., & Elsalam, M. A. (2012). Corporate governance practices and audit quality: An empirical study of the listed companies in Egypt. *World Academy of Science, Engineering and Technology*, (71), 1292–1297.
- Song, J., & Windram, B. (2000). Benchmarking audit committee effectiveness in the UK . Working Paper, Napier University
- Sori, Z. M., Ali, M., Hamid, A., & Evans, J. G. (2007). Audit committee authority and effectiveness: The perceptions of Malaysian senior managers. *International Journal of Research and Economics*, (8), 42–56.
- Tackett, J. A., Wolf, F. M., & Claypool, G. A. (2006). Fraud specialists on independent audits. *Journal of Business and Economics Research*, 4(7), 63–68.
- Velnampy, T., Sivathaasan, N., Tharanika, R., & Sinthuja, M. (2014). Board leadership structure , audit committee and audit quality: Evidence from manufacturing companies in Sri Lanka. *International Journal of Business and Management*, 9(4), 76–85. doi:10.5539/ijbm.v9n4p76
- Wan- Hussin, W. N., & Haji-Abdullah, N. M. (2009). Audit committee attributes, financial distress and the quality of financial reporting in Malaysia. Working Paper, University of Utara, Malaysia.

THE EFFECTIVENESS OF AUDIT COMMITTEES IN NIGERIAN BANKS: IMPLICATIONS ON THE QUALITY OF FINANCIAL REPORTING

Mbobo Erasmus Mbobo
Austine Nweze, Ph.D, FCA

Abstract

This study on the effectiveness of audit committee and the implications on the quality of financial reporting, seeks to investigate the extent to which audit committees in Nigerian banks are effective in carrying out their statutory responsibilities. The main objective of the study is to examine the attributes of audit committee which enhance effectiveness and the relationship between these attributes and the quality of corporate financial reports. In this study, quality financial reporting is measured using the IFRS qualitative characteristics. A review of audit committee literature reveals certain attributes that can enhance the effectiveness of audit committees. These attributes are used as benchmarks for assessing effectiveness. The study adopts a content analysis approach. Data relating to the quality of financial reporting and audit committee attributes are extracted from annual reports of the study banks. The target population of study consists of all banks operating in Nigeria as at 31st December 2013. The sample size of ten (10) banks is determined through filtering process. Seven hypotheses are formulated and tested, using univariate and multivariate techniques to determine if certain audit committee attributes enhance the quality of financial reporting. The results reveal that there is a significant relationship between audit committee effectiveness and the quality of financial reporting. Also, qualitative attributes such as accounting and industry expertise are positively associated with the quality of financial reporting than the quantitative attributes. Following these findings, it is recommended that regulatory agencies should emphasis the qualitative attributes in their oversight functions to enhance audit committee effectiveness and improvement in the quality of financial reporting.

Key Words: Audit committee, audit committee effectiveness, quality financial reporting, Nigerian banks.

Introduction

The integrity of financial reports of corporate organizations in Nigeria, and in other parts of the world has been a subject of debate among accounting academics and practitioners for a very long time (Higson, 2003). The thrust of the debate has been on the role of key operators in the corporate governance framework (such as management, internal auditors, external auditors and audit committees) in enhancing good quality financial reporting. Improvement in the quality of financial reporting practices is often proposed as one of the major reasons why companies establish audit committees (Treadway Commission, 1987; Blue Ribbon Committee, 1999). But the extent to which the existence of audit committee has resulted to quality financial reporting has yet not been successfully proven.

The concern for quality financial reporting stems from the fact that financial report is the medium by which organizations communicate to the owners and the external society about their operational performance. Thus, financial reports serve as a means by which the owners can gauge the health status of their organizations. Financial reports are needed by various users (such as investors, creditors, customers, regulators, government agencies and analysts) as a guide for decision making. In addition, the users also need the financial reports to assess the viability of a company and its ability to continue as a going concern. It therefore becomes imperative that such reports should disclose accurate and reliable information. As noted by Abubakar (2011), when the financial reports disclose quality information, the decision of the users of the reports could as well be qualitative and informed.

Financial reports are regarded as being of good quality when they reflect the true financial position and operational performance of the organization. On the other hand, financial reports that have been subjected to manipulations and creative accounting practices are regarded as being of low quality - They symbolize fraudulent financial reporting.

Fraudulent financial reporting has contributed to the high rate of business failures in recent times, especially in the Nigerian banking sector. These failures, such as Oceanic Bank Plc, Afribank Plc and Intercontinental bank Plc have left in their trails, dire consequences and hardship to the shareholders

as well as bank depositors. Many shareholders have lost huge investments as a result of the failure of their companies. Also, many depositors have lost their life-time savings in failed banks and as a consequence, many have died of heart attacks due to this tragedy. Many honest businessmen and investors have been rendered bankrupt. Indeed, many people have committed suicide and many have died because they were unable to pay medical bills, as their monies were trapped in these failed institutions (Sanusi, 2010).

Audit committee is often seen as having the potentials to address the problem of fraudulent financial reporting (Blue Ribbon Committee, 1999). According to Markham (2006) audit committee was first introduced in the USA following the McKesson and Robbins financial scandal in 1939. The US-SEC recommended the formation of audit committee by public companies, to oversee their financial reporting processes. The New York Stock Exchange, in 1940, also recommended the formation of audit committee as listing requirement for all public companies. Since then, formation of audit committee becomes a global practice. The United Kingdom, Australia, Canada, Malaysia, Singapore and South Africa (among other countries) all mandated their public companies to establish audit committee, as part of their corporate structure. In Nigeria, the Companies and Allied Matters Act (CAMA, 1990, as amended to date), the Security and Exchange Commission (SEC Code, 2003) and the Central Bank of Nigeria's code of corporate governance for banks (CBN Code, 2006) provide for the establishment of audit committee by public companies. Although these organizations have formed audit committees as a legal requirement, the effectiveness of these committees and the extent to which they can enhance quality financial reporting in Nigeria is, as yet, unknown.

Although prior studies have examined the relationship between audit committee attributes and the quality of financial reporting of firms (e.g., Xie, Davidson & DeDalt, 2001; Yang & Krishnan, 2005), most of these studies were based on samples and data obtained from the more developed economies such as the USA, the UK and Australia. The Nigerian economy, especially the banking sector, therefore presents a unique setting where this relationship could also be empirically examined. It is this state of mind that motivated this study.

The rest of the paper is organized as follows: section two presents a review of related literature and the development of hypotheses. The methodology of

the study is presented in section three. The results of findings are presented and discussed in section four; and section five concludes the study.

2.0 Review of Related Literature and Development of Hypotheses

Roles and Responsibilities of Audit Committee

The Committee of Sponsoring Organisations of the Treadway Commission (COSO, 1987) summarized the basic responsibilities of audit committees into three main objectives, namely: supervising the financial reporting process, perfecting the internal control system and oversight over the external auditing as well as enhancing auditor's independence (Lee, 2011). It could however be argued that audit committee has one cardinal objective, performed through three or four processes. The cardinal objective of audit committee is to ensure quality financial reporting (or oversight over financial reporting process). Other objectives such as perfecting the internal control process, oversight over external auditing process and enhancement of auditor's independence are means of achieving the cardinal objective. For instance, the essence of a good internal control system is to guarantee the accuracy of the underlying records which form the basis for the preparation of financial reports. The understanding is that, if the underlying records are defective and fraudulent, the final product, that is, financial report could not be expected to be of high quality.

Similarly, all the activities of an audit committee towards external auditing are aimed at ensuring the integrity of financial statements over which external auditors expressed opinion. Given that the function of external auditors is to examine the set of financial statements presented to them as well as the underlying records thereto, and expressed an opinion as to the accuracy or otherwise of those financial records/statements, their opinions are usually regarded as a stamp of approval of the financial reports. Indeed, their opinion enhances reliance on the financial reports and portends a clean bill of health to the organization for which they report. Thus, the external auditor must have the technical capacity and deploy adequate resources to carry out this assignment in order to ensure that their opinions are accurate and reliable. Furthermore, external auditors must be free from undue influence from management (the preparers of the financial statement), so that they should have the courage to issue a qualify audit opinion if and when such need arises. All these are aimed at improving the quality of financial reporting and thus enhance reliance on the financial reports of the organization. Technically, however, these roles can be seen as separate

functions of audit committees. It follows therefore that, in measuring the effectiveness of audit committees, emphasis is usually placed on the extent to which they perform these key functions.

Audit Committees' Effectiveness

The effectiveness of audit committee in performing its statutory functions has been a focal point in corporate governance discourse among academics and practitioners for many years (e.g. Levitt, 1999; Abbott et al., 2000; Felo et al., 2003; Markham, 2006; Archambeault, Dezoort & Hermanson, 2008; Wu, 2012). The interest in audit committee effectiveness came to the fore following a series of financial frauds and massive financial reporting misstatement in the late 1960s down to 2000s. Indeed, financial fraud and accounting scandals became so rampant in the twenty first century, in spite the existence of audit committees in these companies; thus making people to question the effectiveness of audit committees and their ability to curb financial misstatement and corporate fraud.

The concern towards improving the quality of financial reporting has equally received adequate research attention. For instance, the National Commission on Fraudulent Financial Reporting (the Treadway Commission) was set up in 1987 to find out factors responsible for high scale financial reporting fraud and how to curb it. The Public Oversight Board (1994) the Blue Ribbon Committee (1999) and the Sarbanes Oxley Act (2002), all made far reaching recommendations on curbing fraudulent financial reporting. Most of these recommendations include strengthening audit committees towards effectiveness. Since the main responsibility of the audit committee is to oversee the firm's financial reporting process, we use quality financial reporting as a proxy for audit committee effectiveness.

Determinants of audit committee effectiveness

According to Sabia and Goodfellow (2005), an audit committee cannot be effective if it does not have the "right people" as members. Further, Bedard and Gendron (2009) discussed composition as the determinant of audit committee effectiveness in terms of independence and competencies.

Audit committee Independence

In order to be able to conduct effective monitoring and thus reduce chances of opportunistic management behaviour, audit committee should be independent from management. The argument is that the quality and credibility of financial reporting can be badly affected when the audit

committee has low or no independence. Members' independence is generally defined as the absence of relationship that could bring undue influence upon the judgment of audit committee member. SOX (2002) define independent directors as those having no 'significant interest' with the company. This means that they are: 1) not former employees of the company, 2) not former directors, 3) not the clients or the suppliers of the company, 4) not occupationally related with the company, 5) not recommended or appointed on the basis of personal relations, 6) have no close relation to any executive director, and 7) do not have a significant share or represent major shareholder. Section 301 of SOX (2002) stresses that to enhance the independence of audit committees, it must be formed by independent directors, who must not receive consultation fees or reward, and must not take part in any related transactions with the company or its subsidiary. The expectation is that effective, independent/non-executive directors should have both, strong incentives to monitor the management, and the capabilities to identify earnings management or fraudulent financial reporting. Accordingly, we hypothesized as follows:

H₀₁ the proportion of independent members on the audit committee does not significantly affect its effectiveness and by extension, the quality of its financial reports.

Audit committee Expertise

Contemporary corporate governance best practices recommend that audit committee members should possess a set of competencies or certain personal attributes. Accordingly, some regulators have institutionalized competencies by requiring every audit committee member to be financially literate, and also demand companies to disclose whether at least one of their audit committee members is an "audit committee financial expert" (SEC 2003). Several studies have examined the concept and its impact on the effectiveness of audit committee (DeZoort ,1998; DeZoort and Salterio ,2001). The definition of 'expertise' has been broadened to include accounting expertise (DeFond et al., 2005) and banking expertise (Xie et al., 2003) and industry expertise (Dhaliwal et al., 2010). In this study the word financial expertise shall be subsumed by accounting expertise; hence we shall examine the impact of accounting expertise and industry expertise on the effectiveness of audit committee and by extension, the quality of financial reporting.

Accounting expertise

Section 407 of SOX (2002) required the Securities Exchange Commission to adopt rules mandating that audit committees of public firms contain at least one member who is deemed a financial expert. The SEC's initial definition of financial expert was one who had education or experience in accounting or auditing. However, many companies criticized this initial definition of a financial expert for being overly restrictive and severely limiting the pool of qualified financial experts (Bryan-Low 2002; cited in Abernathy 2010). According to Abernathy (2010) SEC responded to these concerns by expanding the definition of the audit committee financial expert to include non-accounting financial experts.

This broader definition of audit committee financial expert gave rise to a stream of academic research investigating the association between the type of financial expertise on the audit committee (accounting and non-accounting) and the quality of financial reporting (e.g. Xie et al. 2003; Bédard et al. 2004; Defond et al. 2005; Carcello et al. 2006). The findings of these studies are consistent with the expectation that an audit committee member with financial/or accounting expertise enhances committee performance. However, these studies measure financial expertise differently. For instance, while Bedard et al. (2004) use a strict definition of financial expertise, and find it is positively associated with earnings quality, Xie et al. (2003) define financial expertise in terms of investment banking experience. They conclude that investment banking experience is effective in improving earnings quality. Defond et al. (2005) on the other hand posit that accounting expertise, rather than broader financial expertise, improves the effectiveness of an audit committee.

In spite of the varied definitions of expertise, SOX (2002) emphasize accounting expertise over and above financial literacy. The argument is that audit committee's responsibilities often require significant accounting sophistication, in that they involve assessing the reasonableness of complex financial matters. Audit committee members with accounting background can decrease the possibility of earnings management and the errors in financial reporting; and thus, increase the quality of financial reports. Accordingly, the second hypothesis states as follows:

H₀₂ the number of audit committee members with accounting expertise does not significantly

affect the effectiveness of the audit committee and by extension, the quality of financial reports.

Industry Experience

In addition to accounting expertise as core competencies, researchers have examined other competencies such as industry or governance experience. It is important that audit committee members have experience which fitted into the organisation's context. As noted by Dhaliwal, Naiker and Navissi (2010), industry experience could have a great impact on audit committee's effectiveness in overseeing the financial reporting process of the organization, and thus enhances the integrity of the financial statements. They argued that the business and industry knowledge possessed by audit committee members can complement the domain-specific knowledge of accounting expertise, to promote accounting quality. Cohen, Krishnamoorthy and Wright (2008) argued that audit committee members with industry experience are likely to have a superior ability to understand, interpret, and assess the quality of financial reports than members with no such experience. Kang, Kilgore and Wright (2011) defined industry experience in terms of having been in the same industry for a period of at least twenty years. Accordingly, the third hypothesis reads as follows:

H₀₃ the number of audit committee members with industry experience does not significantly

affect the effectiveness of the audit committee and by extension, the quality of financial reports.

Audit committee Charter

The authority of audit committee has been identified as another determinant of the effectiveness of audit committee. Authority is usually expressed by formal appointment and clear definition of roles and responsibilities. As noted by Kalbers and Fogarty (1993), formalizing audit committees' responsibilities in a written charter provides legitimate capacity to perform. Audit committee should have the power to demand and obtain explanation from management on any aspect of the company's activities. In particular, the audit committee is directly responsible for the appointment and compensation of the external auditor and oversees the external auditing functions, as well as resolving any disagreements over financial reporting

between management and the external auditor. The scope of audit committee's responsibilities and how it carries out these responsibilities are generally stated in a formal written charter. The document also confers some formal responsibilities to the audit committee regarding internal control functions. Written charters constitute relevant means of assessing the effectiveness of audit committee. Accordingly, hypothesis' four state as follows:

H₀₄ the existence of audit committee charter does not significantly affect the effectiveness of the audit committee and by extension, the quality of financial reports.

Resources of the Audit Committee – Number of Directors (Size)

Because of the scope of audit committee's responsibilities and the complex nature of its assignments, especially those relating to the accounting and financial matters to be reviewed, it is widely agreed that the committee needs significant resources (PricewaterhouseCoopers, 2006). These resources include human, money, material and information resources. In this study, the resource which is emphasized and which is easily measurable is the human resource, expressed in terms of the number of directors in the audit committee, or simply as the audit committee size.

The size of an audit committee may have effect on its effectiveness. The BRC (1999), the US-SEC (1999) and SOX (2002) recommend that audit committees consist of a minimum of three directors. The CAMA (2004) however recommends a maximum of six directors for audit committees in Nigeria. In the US, most of the audit committees are comprised of three or four directors; three to six directors seems to be the optimum number for an audit committee (Pricewaterhouse,1993). Vafeas (2000) documents that the earnings-return relationship is strong for firms with smaller board size, than for firms with large boards, since members of a small board will be more likely to take responsibility for monitoring the firm's activities. Along the same line of argument, Jensen (1993) states that when boards get beyond seven or eight people, they are less likely to function effectively and are easier for the CEOs to control it. Often times such boards are characterized by slower decision-making (Goodstein, Gautam & Boeker, 1994); are less cohesive (Lipton & Lorsh, 1992); are more fragmented and easily manipulated by management (Alexander, Fennell & Halpern, 1993). Felo et al. (2003), however, agreed that a larger audit committee increases the

quality of financial reporting. Also, Lin et al. (2006) find that firms with audit committees consisting of at least four members are less likely to experience earnings restatements. The general expectation is that a large audit committee would enhance the effectiveness of the committee and by extension the quality of financial reporting of the firm. Following this argument, we hypothesis as follows:

H₀₅ the size of audit committee does not significantly affect its effectiveness and by extension, the quality of financial reports.

Audit Committee Process - Audit Committee Meetings

The formal and informal processes undertaken by the audit committee in conducting its affairs is as important as having independent and competent audit committee members with the necessary resources to monitor financial reporting process and oversee the internal control system and the external auditing functions. It is therefore important to examine the mechanisms or processes by which audit committee characteristics are translated into organizational outcomes. This process is achieved through reasonable number of meetings and regular attendance of such meetings by members

a. Frequency of Meetings

The number of audit committee meetings has been used frequently as proxy for diligence and activeness of audit committees in corporate governance literature (McMullen and Raghunandan, 1996; Song and Windram, 2004; Al-Lehaidan, 2006). McMullen and Raghunandan (1996) in examining the determinants of audit committee effectiveness used frequency of meetings as a sign of diligence audit committees. Also, Song and Windram (2004) used frequency of meeting as a proxy for audit committee activeness. Bryan, Liu and Tiras (2004) and Koh et al. (2007) are in agreement that audit committee that meets regularly improves the transparency of reported earnings and therefore enhance earning quality (proxy for financial reporting quality).

However, Yang and Krishnan (2005) and He, Wright, Evans and Crowe (2007) found no evidence of a significant relationship between the number of audit committee meetings and earnings management (another proxy for financial reporting quality). Contrary to this position, McMullen and Raghunandan, (1996) document that companies with less audit committee meetings are often found to have problems of financial reporting. O'Sullivan, Percy and Stewart (2008) confirm that audit committee meeting frequency is

positively associated with the disclosure of forward-looking information in financial statements.

It is argued that, the ability of the audit committee to uncover any financial irregularity and resolve problems in the financial reporting process will depend largely on the frequency with which the committee meets to consider issues affecting the company. However, the various corporate governance codes (both the US and Nigeria), have not made any categorical statement on the frequency of audit committee meetings. For instance, section 12 of the SEC code of corporate governance provides that the board of directors (BoD) should meet at least once every quarter; but completely silent on audit committee meetings. It is however expected that since audit committee reports to the board of directors (BOD), its meetings should precede the BOD meeting, hence the need for committee to also meet at least once a quarter.

The expectation is that the more frequent the audit committee meets, the more opportunity it has to discuss issues and problems faced by the organisation. To examine this relationship therefore, we hypothesized as follows:

H₀₆: the frequency of audit committee meetings is not significantly associated with the effectiveness of the committee and by extension, the quality of financial reports.

b. Audit Committee Meetings Attendance

Besides regular meetings, the level of attendance of the meetings by the audit committee members can also determine the activeness of the audit committee. The frequency of meetings may be high, but if the attendance levels are poor, this may impair the effectiveness of the audit committee. Therefore, it is expected that the higher the level of attendance of audit committee members, the more active and participative the audit committee would be, and therefore the better the quality of financial reporting. Wan-Hussin and Haji-Abdullah (2009), argued that irrespective of the number of meetings a firm holds in a year, it is the level of attendance by the audit committee members that determines its effectiveness, and by extension, quality financial reporting.. To examine this relationship, the 7th hypothesis is formulated as follows:

H₀₇: the attendance of audit committee meetings does not significantly affect the effectiveness of the committee and by extension, the quality of financial reports.

3.0 Research Methodology

The study adopts a content analysis research design. Data from financial statements of selected banks are extracted for analysis in order to examine the relationship between the various audit committee attributes and the quality of financial reporting, as a measure of effectiveness. The quality of financial reporting is measured using IFRS qualitative characteristics, proposed by the IASB (2008 and 2010). To achieve this we develop a quality index (QI). The QI is determined through the evaluation of the contents of annual reports of the study banks, using the researcher-constructed checklist and is calculated using Beest et al. (2009) model of measuring the quality of financial reporting. This model takes cognizance of the qualitative characteristics of financial reporting, espoused by the International Financial Reporting Standards (issued by the IASB).

The choice of this model is justified by the fact that Nigerian banks have adopted the IFRS. Also, this model, according to Beest et al (2009), provides a direct measure of the quality of financial reporting and decision usefulness of financial information. Alternative approach would have been to use the accrual models, represented by Jones (1991) and Dechow et al. (1995). Studies which used this approach include Baxter (2007); Baxter and Cottier (2009) and Samuel (2012). Most studies in this research area used accrual model or instances of financial statement fraud as a measure of (e.g. Abbot, et al. (2000); Song and Windram (2004) and Sharma (2004). These models use earnings management/quality as a proxy for the quality of financial reporting. This study overcome this limitation by using a direct measure of financial reporting quality.

Population and Sample Size

The population for this study consists of all deposit money banks operating in Nigeria. According to the CBN record, a total of twenty two banks were operating in the country at 31st December, 2014. In deciding on the actual population, however, consideration was given to the period covered by the report and the number of banks during the intervening years. Accordingly, a sample size of ten (10) banks was determined through filtering process.

In terms of coverage, this study covers eight years reporting periods - from January 2006 to December 2013. This period is significant in that, it covers the period when the first code of corporate governance (CBN code of corporate governance), with emphasis of the functions of audit committees came into existence; as well as the pre and post IFRS period.

Data Collection Instrument

A researcher-constructed measurement check-list was used to extract information from the audited annual reports. The construction of the checklist draws from Beest et al. (2009). The checklist was divided into three main sections. Section A consisted of issues relating to the quality of financial reports, based on the IFRS qualitative characteristics, section B was made up of items relating to the attributes of audit committee, while section C contains items relating to board’s characteristics (for control variables) . The checklist was on a three point scale. An item which adequately meets the IFRS qualitative characteristics was assigned the value of ‘3’; if it is fairly met, the value of ‘2’ was assigned; while ‘1’ was assigned if it does not, or meets in a very little way. Data for the completion of sections A of the checklist was extracted from the financial statements of the study banks, while sections B and C were gleaned from the corporate governance report and director’s report sections of the annual reports.

Identification and Measurement of Variables:

Dependent variable:

The main construct investigated in this study was the quality of financial reporting. This construct was measured using the IFRS qualitative characteristics. The alternative way of capturing this construct would have been to use a proxy, such as earnings management/earnings quality, or a third party assessment of the quality of financial reporting, or a survey of stakeholders’ perceptions on the quality of financial reporting. However, as stated in section 2.3.4 of this thesis, these approaches are fraught with several limitations. The qualitative characteristics model is the approach which tends to overcome the limitations of these other approaches. Therefore, the quality of financial reporting (QFR), which is the dependable variable in this study, was measured using the qualitative characteristics model. The model is stated as follows:

$$FEQC_{kt} = f(RL_{kt}+FR_{kt}+UN_{kt}+CM_{kt}+TM_{kt}+ \epsilon_t) \dots\dots\dots (1)$$

Where:

$FEQC_{kt}$ = The fundamental and enhancing qualitative characteristics of financial reports for bank k in year t

RL_{kt} = Relevance characteristic scores for bank k in year t

FR_{kt} = Faithful representation characteristics scores for bank k in year t

UN_{kt} = Understandability characteristic scores for bank k in year t

CM_{kt} = Comparability characteristic scores for bank k in year t

TM_{kt} = Timeliness characteristic scores for bank k in year t

ε_t = Error term

Independent variable:

A summary of independent variables and their measures is presented in table 1.

Table 1: Summary of Independent and Control Variables and their Measurement

Type of Variable	Name	How the Variable was Measured
Independent Variables		
	ACSIZE	The number of directors on the audit Committee at the year end.
	ACIND	- The proportion of independent/non executive directors on the audit committee
	ACACCEXP	- The existence of audit committee chairman who is not the chairman of the board of directors. A dummy '1' is assigned if the AC chair is separate from board chair and '0' if otherwise. A dummy '1' is assigned if the AC consist of At least one member with professional Qualification in Accounting; and also if the Audit committee chairman is financially literate and '0' if otherwise
	ACINDEXP	The proportion of audit committee members with board membership in the banking industry for a reasonable number of years.
	ACMEET	The actual number of audit committee Meetings held during the year.
	ACMEEATT	The proportion of meetings attendance by Audit committee members to the total number of meetings held during the year.
	ACCHART	The existence of a written charter to guide the members of the audit committee. A dummy '1' is assigned if there is a written charter/terms of reference and '0' if otherwise

Control Variables	BDSIZE	The number of directors on the board.
	BDIND	The proportion of independent directors on the board.
	BDACCEXP	The proportion of board members with professional accounting qualifications
	BDINEXP	The proportion of board members with Board membership in the banking industry for a reasonable number of years.
	BDMEET	The number of board meetings held during the year.
	AUDITOR	1, if a bank's auditor is one of the Big 4 firms, and 0 if otherwise.
	LNSIZE	The natural log of the total assets.

$$QFR = f (ACSIZE + ACIND + ACACCEXP + ACINDEXP + ACMEET + ACMEETATT + ACCHART + \varepsilon \dots\dots\dots (2)$$

Where:

QFR = The fundamental and enhancing qualitative characteristics of financial reports for firm k in year t

ACSIZE = Audit Committee Size

ACIND = Audit Committee independence

ACACCEXP = Audit Committee accounting expertise

ACINDEXP = Audit Committee industry experience

ACMEET = Audit Committee frequency of meetings

ACMEETATT = Audit Committee meeting attendance

ACCHART = Audit Committee charter

ε = Error term

Model Specification

The relationship between the determinants of audit committee effectiveness (independent variables) and the quality of financial reporting (dependent variable) is analyzed using the following model:

$$QFR_{kt} = \alpha_t + \beta_{1t} ACSIZE + \beta_{2t} ACIND + \beta_{3t} ACACCEXP + \beta_{4t} ACINDEXP + \beta_{5t} ACMEET + \beta_{6t} ACMEETATT + \beta_{7t} ACCHART + \beta_{8t} BDSIZE + \beta_{9t} BDIND + \beta_{10t} BDACCEXP + \beta_{11t} BDINDEXP + \beta_{12t} BDMEET + \beta_{13t} AUDITOR + \beta_{14t} LNSIZE + \varepsilon_t$$

The terms in this model were measured as follows:

QFR_{kt} = The measures for quality financial reporting, calculated as the total

scores for the fundamental and enhancing qualitative characteristics

for bank k in year t;

ACSIZE = The number of directors on the audit committee at the year end.

ACIND = The proportion of independent/non executive directors on the audit

committee and the existence of audit committee chairman who is

not the chairman of the board of directors. A dummy '1' is assigned

if the AC chair is separate from board chair and '0' if otherwise.

ACACCEXP = Audit committee accounting expertise. A dummy '1' is assigned

if the AC consist of at least one member with professional qualification in Accounting; and also if the audit committee chairman is financially literate and '0' if otherwise

ACINDEXP = The proportion of audit committee members with board membership in the banking industry for a reasonable number of

years.

ACMEET = The actual number of audit committee meetings held during the

Year;

ACMEEATT = The proportion of meetings attendance by audit committee members to the total number of meetings held during the year;

ACCHART = The existence of a written charter to guide the members of the audit committee. A dummy '1' is assigned if there is a written charter/terms of reference and '0' if otherwise;

BDSIZE = The number of directors on the board;

BDIND = The proportion of independent directors on the board;

BDACCEXP = The proportion of board members with professional accounting qualifications;

BDINDEXP = The proportion of board members with board membership in the banking industry for a reasonable number of years;

BDMEET = The number of board meetings during the year;

AUDITOR = The type of auditor. '1' if the bank's auditor is a Big 4 firm and '0' if otherwise;

LNSIZE = The natural log of total assets.

4.0 Analysis and Discussions of Findings

4.1 Operational Measure for Qualitative Characteristics

Table 2: Operational Measures Utilised for the Qualitative Characteristics

Qualitative Characteristics	Items	Mean	Min	Max	Std. Dev
Relevance					
R1	Whether the financial reports disclose forward-looking information?	2.925	1	3	0.3477
R2	Whether the financial reports disclose information in terms of business opportunities and risks	2.775	1	3	0.4767
R3	Whether the bank uses fair value accounting as measurement basis in the financial statements?	1.275	1	3	0.4767
R4	Whether the financial reports provide information as to how various market events and significant transactions affect the bank	2.175	1	3	0.8535
R5	Whether the financial reports contain Analysis section which provides a feedback on evaluating financial statements	1.725	<u>1</u>	<u>3</u>	<u>0.6556</u>
Total					
Score for Relevance		10.875			2.8101

Faithful Representation					
F1	Whether the financial reports explain the assumptions and estimates made in the preparation of financial statements?	2.5	1	3	0.5953
F2	Whether the financial reports explain the choice of accounting principles used in the preparation of financial statements?	2.675	1	3	0.5687
F3	Whether financial reports highlight the positive events as well as the negative events in a balanced way in the annual reports?	2.775	1	3	0.4767
F4	The type of auditors' report is contained in the annual reports	2.95	1	3	0.271
F5	Whether the financial reports disclose information on corporate governance issues?	2.8375	<u>1</u>	<u>3</u>	<u>0.489</u>
Total Score for Faithful Representation		13.738			
Total Score for Fundamental (F) Characteristics		24.613			2.4006

Understandability					
U1	Whether information presented in the annual financial are well organized	2.875	1	3	0.4017
U2	The clarity the financial statements in terms of table of contents, headings, order of components and summary?	2.475	1	3	0.636
U3	Whether financial reports make use of graphs and tables to clarify information presented in the reports	1.9375	1	3	0.8167
U4	Whether the financial reports are devoid of jargons and technical terminologies.	2.35	1	3	0.6183
U5	Whether the glossary of unfamiliar terms and abbreviations are detailed enough	1.0125	<u>1</u>	<u>2</u>	<u>0.1118</u>
Total Score for Understandability		10.65			2.5844

Characteristic	Mean	Min	Max	Item	Std. Dev
C1			Whether the financial reports show explanation of the implications of the changes in accounting policies	2.6125	1 3 0.6462
C2			Whether the financial reports explained the implications of the revisions in accounting estimates and judgments	2.725	1 3 0.5506
C3			Whether the bank adjust previous accounting periods figures, for the effect of the implementation of a change in policy	2.3	1 3 0.5131
C4			Whether the figures of the current accounting period are compared with the previous period's results	2.8875	1 3 0.4208
C5			Whether there is provision of information for comparison with other banks in Nigeria	1.175	1 3 0.5687
C6			Whether financial reports includes financial index numbers and ratios for analysis.	1	<u>1</u> <u>1</u> 0
Total Score for Comparability				12.7	<u>2.6994</u>

Timeliness					
T1	The length of time it takes for the auditor to sign the auditors' report after book-year end.	1.1125	<u>1</u>	<u>3</u>	<u>0.3556</u>
Total Score for Timeliness		1.1125	1	3	0.3556
Total Score for Enhancing (E) Characteristics		24.463			
FEQC Score		<u>49.075</u>			

Table 2 shows the operational measures utilised for the qualitative characteristics. From the table, the total mean score for relevance is 10.875; faithful representation is 13.875, giving the total mean score for fundamental characteristics as 24.613. The mean score for the enhancing characteristics is as follows: understandability, 10.650; comparability, 12.700 and timeliness is 1.113; giving a total for enhancing characteristics as 24.463. The overall mean score for all the characteristics is 49.075. Against expected mean score of 66, this signifies a reasonable high quality.

4.2 Presentation and Discussion of Descriptive Statistics

Table 3: Descriptive Statistics for Continuous Variables

Variable	Mean	Std. Dev	Minimum	Maximum
Quality Financial Reporting (QFR)	21.0651	4.04410	12.34	35.98
Audit Committee Size (ACSIZE)	5.8125	0.99484	0.00	6.00
Audit Committee Independence (ACIND)	0.6288	0.08597	0.50	0.80
Audit Committee Accounting Expertise (ACCTEXP)	4.0000	0.71157	2.00	6.00
Audit Committee Industry Experience (ACINDEXP)	2.2750	0.50253	1.00	3.00
Audit Committee Meeting (ACMEET)	3.7250	0.76266	2.00	6.00
Audit Committee Meeting Attendance (ACMEETATT)	0.8625	0.08778	0.50	1.00
Audit Committee Chart (ACCHART)	1.7500	0.43574	1.00	2.00
Board Size (BDSIZE)	14.4625	2.28890	10.00	20.00
Board Independence (BDIND)	0.5760	0.08037	0.42	0.80
Board Accounting Expertise (BDACCTEXP)	5.3375	0.47584	5.00	6.00
Board Industry Experience (BDINDEXP)	3.0000	0.00000	3.00	3.00
Board Meetings (BDMEET)	6.1125	1.63036	3.00	12.00
Auditor	1.0000	0.00000	1.00	1.00

Descriptive Statistics

Table 3 presents the results of the descriptive statistics for all the variables tested in study. The mean value of QFR is 21.1, which gives a low quality of financial reporting in Nigerian Banks.

The mean value for audit committee size is 5.8, while the maximum value is 6. This implies that almost all the banks comply with the minimum requirement for member of audit committee members; and the average board size is within international best practice standard.

Sixty three (63%) of the AC members in Nigerian banks are independent non-executive directors, while 58% of board members are also independent directors. The average number of meetings held in a year is four times with 86% attendance.

4.3 Presentation and Discussion of Correlation Coefficients

Table 4: Regression Results between Audit Committee Attributes and Quality Financial Reporting.

Variable	Std. Coefficients	T-Value	Significance
	Beta		
QFR		8.205	0.000
Audit Committee Size (ACSIZE)	0.003	0.022	0.982
Audit Committee Independence (ACIND)	-0.003	-0.019	0.985
Audit Committee Accounting Expertise (ACACCTEXP)	0.268	1.873	0.065*
Audit Committee Industry Experience (ACINDEXP)	-0.262	-1.783	0.079*
Audit Committee Meeting (ACMEET)	0.087	0.708	0.482
Audit Committee Meeting Attendance (ACMEETATTEND)	-0.040	-0.301	0.764
Audit Committee Charter (ACCHART)	0.398	2.792	0.007***
Board Size (BDSIZE)	-0.039	-0.245	0.808
Board Independence (BDIND)	-0.049	-0.343	0.733
Board Accounting Expertise (BDACCTEXP)	-0.235	-1.705	0.093*
Board Meetings (BDMEET)	0.001	0.007	0.994
Board Meeting Attendance (BDMEETATTEND)	0.029	0.242	0.809

Model Summary			
R	0.433		
R ²	0.188		
Adj. R ²	0.042		
Standard Error of Estimate	0.18008		
F-Value	1.29		
Significance	0.244		

NOTE: *Significant at 10% level of probability ** Significant at 5% level of probability ***Significant at 1% level of probability

Table 3 presents the regression results of relationship between audit committee effectiveness attributes and the quality of financial reporting in Nigerian banks. The result suggests that the independence of AC does not affect its effectiveness and by extension the quality of financial reporting. Accordingly, hypothesis one, which states that the proportion of independent members on the audit committee does not significantly affect the quality, its effectiveness, and by extension, the quality of financial reporting, is accepted in preference to the alternative hypothesis. This result is in agreement with Peasnell, et. al. (2005) who found no evidence to show that the presence of outside board members (independent directors) affects the extent of earnings management.

The results however show that the expertise of audit committee members has a positive effect on its effectiveness, and by extension the quality of financial reporting. Thus it provides evidence for the rejection of the second hypothesis, which states that the number of audit committee members with accounting expertise does not significantly affect the effectiveness of the audit committee and by extension, the quality of financial reporting. The results reveal that accounting experts significantly impact on the effectiveness of audit committee in the execution of its responsibilities over the financial reporting activities. This finding is in agreement with the UK study by Song and Windram (2004) who reported that financial literacy is an important determinant of audit committee's effectiveness. The result however negates the position of Dezoort (1997) whose study did not recognize the perceived need for accounting or auditing expertise in an audit committee.

The results on table 3 also show that the number of audit committee members with industry experience has a significantly affect on the effectiveness of the committee and by extension, the quality of financial reporting of the firm. Accordingly, hypothesis three is accepted. This result contradicts Bedard et al. (2004) who found no association between earnings quality (proxy for quality financial reporting) and industry or firm-specific expertise.

The existence of audit committee charter/terms of reference to guide members in carrying out their functions has a significant impact on the

effectiveness of the audit committee, and by extension on the quality of financial reporting. The result of this test gives us ample ground to reject the null hypothesis which states that the existence of audit committee charter does not significantly affect the effectiveness of audit committee. This result supports the position of Al-Lehaidan (200) who in a sample of 190 audit committee members in Australia concluded that firms with an audit committee and with a written charter are more likely to select a high-quality external auditor (proxy for effectiveness) than firms without written charter.

The results on table 3 also show that the size of audit committee has little or no effect on the effectiveness of audit committee, and by extension, on the quality of financial reporting. This confirms the fifth hypothesis which states that the size of audit committee does not significantly affect its effectiveness, and by extension, the quality of financial reporting. Accordingly, hypothesis 5 is accepted in preference to the alternate hypothesis. This findings confirm that of Xie et al (2001) who concluded that there is no significant association between audit committee size and aggressive earnings management.

Similarly, the number of meeting held by the audit committee and the attendance at such meetings has no significant impact on the effectiveness of the committee, and by extension, on the quality of financial reporting. Contrary to expectation, the coefficients of both tests show no significant relationship; hence both hypotheses six and seven are accepted in place of the alternate ones. These results confirm the studies of Abbott et al. (2004) who found no relationship between frequency of meetings and audit committee effectiveness; but contradict the study of Wan-Hussin and Aldallah who in their study of 68 Malaysian firms, concluded that the level of meeting attendance by audit committee members significantly affects the quality of financial reporting.

5.0 Summary and Conclusion

The main focus of this study is to examine the effectiveness of audit committee in Nigerian banks and how such effectiveness translates to quality financial reporting. The major functions/roles of audit committee has been analysed, namely role over internal control; role over external auditing/auditor's independence and role over financial reporting process. We argued that all these functions/roles are aimed at achieving good quality financial reporting. We also argued in this study that the best way to assess an audit committee is to evaluate its contributions towards achieving quality financial reporting.

Accordingly, we identified seven key determinants of audit committee effectiveness, namely: independence; accounting expertise, industry experience, size of the audit committee, frequency of meeting, meeting attendance, and existence of a written charter/terms of reference.

These determinants/attributes were tested against the quality of financial reporting (QFR) which we used as the dependent variable. The model adopted for measuring the quality of financial reporting is the qualitative characteristics of financial reporting, as propounded by the IASB. The model which is an adaption of Beeest et al. (2009) measures the fundamental and enhancing qualitative characteristics of financial reports for the 10 study banks for eight year period.

The independent variables were tested against the dependent variables using the exponential model of multiple regressions. The results of the test show that qualitative attributes such as accounting expertise and industry experience, has greater significance on the effectiveness of audit committee and by extension, the quality of financial reporting, than quantitative attributes like, the size of audit committee, frequency of meetings and meetings attendance. Also, the results underscore the importance of a written charter to guide the audit committee members. However, contrary to expectations, the study's results give no importance to independence of the committee as having significant effect on the effectiveness of the committee and also the quality of financial reporting. This calls for a further study on the effect of audit committee independence on the effectiveness of audit committees.

REFERENCES

- Abbot, L. J., S. Parker and G. F. Peters (2004). Audit committee characteristics and restatements, *Auditing: A Journal of Practice and Theory* 23(1): 69-87
- Abernathy, J.L. (2010). Three Essays on Audit Committees and Financial Reporting Quality, *PhD Dissertation*, The University of Alabama
- Abubakar, S. (2011). Human resource accounting and the quality of financial reporting of quoted service companies in Nigeria. *Ph. D Dissertation*, Ahmadu Bello University, Zaria
- Alexander, J.A., M.L. Fennell, and M.T. Halpern. 1993. Leadership instability in hospitals: The influence of board-CEO relations and organizational growth and decline. *Administrative Science Quarterly* 38 (1): 74-99.
- Al-Lehaidan, I. (2006). Audit committee effectiveness: Australia and Saudi Arabia, *Ph.D thesis*, Victoria University
- Archambeault, D.S., Dezoort, F.T. and Hermanson, D.R. (2008) Audit Committee Incentive Compensation and Accounting Restatements, *Contemporary Accounting Research*, 25(4), 965-92.
- Baxter, P. J. (2007) Audit committees and financial reporting quality. *PhD dissertation*, University of Southern Queensland.

- Baxter, P. and Cotter, J. (2009). Audit committees and earnings quality. *Accounting and Finance*, (49), 267–290
- Beasley, M., Carcello, J., Hermanson, D. and Neal, T. (2009). The audit committee oversight process. *Contemporary Accounting Research*, 26 (1), 65–122.
- Bedard, J., Chtourou, S.M. and Courteau, L. (2004). The effect of audit committee expertise, independence and activity on aggressive earning management, *Auditing: A Journal of Practice and Theory*, 23(2): 13-35.
- Bedard, J. and Gendron, Y. (2009). Strengthening the financial reporting system: Can audit committees deliver? *International Journal of Auditing*, 14: 174-210.
- Beest, F. V., Braam, G. and Boelens, S. (2009). Quality of financial reporting: measuring qualitative characteristics, *Working Paper*, Radboud University The Netherlands
- Blue Ribbon Committee. (1999). *Report and recommendations of the committee on improving the effectiveness of corporate audit committees*. New York: New York Stock Exchange and National Association of Securities Dealers
- Bryan D., Liu, M.H.C. and Tiras, S.L. (2004). The influence of independent and effective audit committees on earnings quality, *Working paper*, State University of New York, Buffalo.
- Cadbury Committee (1992). *Report of the committee on the financial aspects of corporate governance*, London, Gee Publishing Ltd.
- CAMA (2004). Companies and Allied Matters Act, Law of the Federal republic of Nigeria
- Carcello, J. V., Hollingsworth, C. W., Klein, A. & Neal, T. L. (2006). Audit Committee financial expertise, competing governance mechanisms, and earnings management. *Working paper*, University of Tennessee.
- Carcello, J. V., Hollingsworth, C. W., Klein, A. & Neal, T. L. (2008). Audit committee financial expertise, competing corporate governance mechanisms, and earnings management. *Working Paper*, University of Tennessee and New York University.
- Central Bank of Nigeria (2006). *Code of corporate governance code of best practices for banks in Nigeria post consolidation*. Downloaded on 25/6/2014 from <http://www.cenbank.org/>.
- Cohen, J., Krishnamoorthy, G. and Wright, A. (2008). Form versus substance: the implications for auditing practice and research of alternative perspectives on corporate governance. *Auditing: A Journal of Practice & Theory*, 27 (2), 181–198.

- Committee of Sponsoring Organizations of the Treadway Commission (COSO), 1992. Internal control integrated framework. COSO, New York, NY.
- Dechow P., Sloan R.G. and Sweeney A.P. (1995) Detecting earnings management. *The Accounting Review* 70: 193-225.
- Defond, M.L., Hann, R.N. & Hu, X. (2005). 'Does the market value financial expertise on audit committees of boards of directors?' *Journal of Accounting Research*, Vol. 43, (2), 153-193.
- DeZoort, F.T. (1997). An investigation of audit committee oversight responsibilities, *Abacus*, Vol. 33 No.2, pp.208-27
- DeZoort, F. T., Hermanson, D. & Reel, N. (2002). Audit committee effectiveness: a synthesis of the empirical audit committee literature, *Journal of Accounting Literature* 21: 38-75.
- DeZoort, F.T., Hermanson, D.R., Archambeault, D.S. and Reed, S.A. (2002). Audit committee effectiveness: a synthesis of the empirical audit committee literature, *Journal of Accounting Literature* 21, 38–74.
- Dhaliwal, D., Naiker, V. and Navissi, F. (2010). The association between accruals quality and the characteristics of accounting experts and mix of expertise on audit committees. *Contemporary Accounting Research*, 27 (3), 787-827.
- Felo A.J., Krishnamurthy S. and Solieri, S.A. (2003). Audit committee characteristics and the perceived quality of financial reporting: an empirical analysis. *Working Paper*, Graduate School of Professional Studies, Penn State University, Great Valley.
- Goodstein, J., K. Gautam, and W. Boeker. (1994).The effects of board size and diversity on strategic change. *Strategic Management Journal* 15 (3): 241-250.
- He, L., Wright S., Evans E. and Crowe S. (2007) Earnings management in Australia under new ASX corporate governance guidelines. *Working paper*, Macquarie University, North Ryde, N.S.W.
- He, L. , Labelle, R., Piot, C. and Thornton (n.d). Board monitoring, audit committee effectiveness, and financial reporting quality: review and synthesis of empirical evidence, *Journal of Forensic & Investigative Accounting*, Vol. 1, (2), 1- 41
- Higson, A. (2003). Corporate Financial Reporting: Theory and Practice (1st ed.). London: SAGE Publications.
- IASB (2008). *Exposure Draft on an improved Conceptual Framework for Financial Reporting: The Objective of Financial Reporting and Qualitative Characteristics of Decision-useful Financial Reporting Information*. London.
- Jensen, M. 1993. The modern industrial revolution, exit, and the failure of internal control systems. *The Journal of Finance* 48 (July): 831-880.

- Jones, J. (1991). Earnings management during import relief investigations', *Journal of Accounting Research*, vol. 29, no. 2, pp. 193-228.
- Kang, W. S., Kilgore, A. and Wright, S. (2011). The effectiveness of audit committees for low- and mid-cap firms, *Managerial Auditing Journal*, Vol. 26 (7), 623 – 650
- Kalbers, L. and Fogarty, T. 1998, 'Organizational and economic explanations for audit committee oversight', *Journal of Managerial Issues*, vol. X, no. 2, pp. 129-150.
- Koh, P., Laplante, S. and Tong, Y. (2007) Accountability and value enhancement roles of corporate governance, *Accounting and Finance* (47), 305–333.
- Lee, P. C. (2011). The audit committee as an additional mechanism of corporate governance in China *Ph.D thesis*, University of Manchester
- Lin J.W., Li J.F. and Yang J.S. (2006). The effect of audit committee performance on earnings quality. *Managerial Auditing Journal* 21 (9): 921-933.
- Lipton, M., and J. W. Lorsch (1992). A modest proposal for improved corporate governance. *Business Lawyer*, Vol 48(1), pp 59-77.
- Markham, J. W. (2006). A Financial History of Modern U.S. Corporate Scandals: From Enron to Reform. New York, U.S.A.: M.E. Sharpe.
- McDaniel, L., Martin, R.D. & Maines, L.A. (2002). Evaluating financial reporting quality: the effects of financial expertise vs. financial literacy', *The Accounting Review*, Vol. 77, pp. 139-167.
- McMullen, D. A. (1996). Audit committee performance: an investigation of the consequences associated with audit committees. *Auditing: Journal of Practice and Theory* 15 (1), 87-101.
- McMullen, D.A. and Raghunandan, K. (1996). Enhancing audit committee effectiveness, *Journal of Accountancy*, 182(2), 79-81.
- Mohiuddin, M. (2012). An empirical investigation into audit committee practices in Bangladesh: the case of companies listed on the Dhaka stock exchange, *Ph.D thesis* Cardiff University
- O'Sullivan, M., Percy, M., and Stewart, J. (2008). Australian evidence on corporate governance attributes and their association with forward-looking information in the annual report. *Journal of Management and Governance*, 12 (1), 5-35.
- Peasnell, K. V., Pope, P. F., & Young, S. (2000). The characteristics of firms subject to adverse rulings by the Financial Reporting Review Panel. *Accounting and Business Research*, 31 (4), 291-311.

- Price Waterhouse (1993). Improving audit committee performance: what works best. *Institute of Internal Auditors Research Foundation, Altamonte Springs.*
- PricewaterhouseCoopers. (2006). *Results of audit committee benchmarking survey of good practices for listed companies.* PricewaterhouseCoopers LLP. UK.
- Sabia, M.J. and Goodfellow, J.L. (2005). *Integrity in the spotlight*, (2 edition) Toronto: The Canadian Institute of Chartered Accountants (CICA).
- Samuel, G. (2012). Attributes of audit committee members and quality of financial reporting in banks in Nigeria, *M.Sc.thesis*, ABU, Zaria.
- Sanusi, S. L. (2010). The Nigerian banking industry: what went wrong and the way forward. *Convocation Lecture*, Bayero University, Kano.
- Sarbanes-Oxley Act, 2002, *An Act to Protect Investors by Improving the Accuracy and Reliability of Corporate Disclosures Made Pursuant to the Securities Laws, and for Other Purposes.* USA, <http://news.findlaw.com/>
- Securities and Exchange Commission (2003). *Code of corporate governance*, SEC, Lagos
- Securities and Exchange Commission (SEC-US) (2000). *International Accounting Standards, Release NoS.33-7801, 34-42430; International Series No. 1215).*
- Sharma, V. (2004). 'Board of director characteristics, institutional ownership, and fraud: Evidence from Australia', *Auditing: A Journal of Practice and Theory*, Vol. 23, no. 2, pp. 105-117.
- Song, J., and Windram, B. (2004), Benchmarking audit committee effectiveness in financial reporting. Retrieved from <http://www.google.ca> on 15 April, 2013.
- Sori, Z.M., Hamid, M.A.A., Saad, S.S.M., and Evans, J.G. (2007). Audit committee authority and effectiveness, *International Research Journal of Finance and Economics*, (8).
- Treadway Commission Report (1987). Report of the national commission on fraudulent financial reporting, Retrieved on 15/4/13.from <http://www.coso.org>,
- Vafeas N. (2005). Audit committees, boards and the quality of reported earnings. *Contemporary Accounting Research* 22 (4): 1093-1122.
- Wan-Hussin, W. N and Haji-Abdullah, N. M. (2009). Audit committee attributes, financial distress and the quality of financial reporting in Malaysia

- Wu, J. Y. (2012). Audit committee effectiveness – from the perspective of audit committee members, New Zealand listed companies. *PhD Thesis*, Lincoln University.
- Xie B., Davidson W.N. & DeDalt P.J. (2001). Earnings management and corporate governance: the roles of the board and the audit committee. Working paper Southern Illinois University
- Xie, B., Davidson, W. N. & Dadalt, P. T. (2003). Earnings management and corporate governance: the role of the board and the audit committee. *Journal of Corporate Finance* 9(3):295–316
- Yang J.S. & Krishnan J. (2005). Audit committees and quarterly earnings management. *International Journal of Auditing* 9: 201-219
- Yermack, D. 1996. Higher market valuation of companies with a small board of directors. *Journal of Financial Economics* 40:185-211.

PRICING OF EXTERNAL AUDIT SERVICES IN NIGERIA: A DYNAMIC ANALYSIS

SOYEMI Kenny Adedapo

Department of Accounting, Banking & Finance

Olabisi Onabanjo University, Ago Iwoye.

ABSTRACT

This study investigated the pricing of external audit services provided by audit firms to deposit money banks in Nigeria. The Simunic's audit fees model developed for non-financial industrial companies was modified to accommodate specific measures of banks' size, risk, complexity and auditor type. The study used secondary data, gathered through content analysis of 14 sampled banks' annual reports and accounts over the period of 2006-2013. Thereafter, the panel data obtained was analysed by applying the dynamic difference and system Generalised Method of Moment (GMM) estimation techniques. Initially, a comparison was made with the static techniques in order to ascertain the estimation technique upon which this work is hinged upon. Despite the uniqueness in methodology, that is, consideration for the dynamic nature of variables, findings from this study appeared to be largely consistent with previous works. The immediate past amount paid as audit fees (one-year lag of audit fees) displayed a positive and significant influence accounting for 50% (approx.) of the variance in the current fees paid/ payable. Similarly, gross earnings and non-performing loan ratio, proxies for bank size and risk respectively are as well significant drivers of external audit fees in the banking industry.

Keywords: *Audit fees, Pricing, Banks, Difference GMM, System GMM, Nigeria*

INTRODUCTION

The external audit services provided by professional accounting firms is no doubt a key corporate governance mechanism providing an oversight role, especially on the financial management angle of the entity. In addition to providing a generalized definition of auditing, the America Accounting Association (AAA)'s committee on Basic Auditing Concepts also identified four (4) conditions which drive the need for independent audit of accounting data. These are the need to: (1) bridge the potential conflict of interest between the user and the preparer of the financial statements; (2) enhance the credibility of the financial information for decision making; (3) simplify the complexity of the preparation of

financial information, thereby necessitating a third person (auditor) to examine its quality; and (4) enhance accessibility of financial information.

In Nigeria, the Companies and Allied Matters Act, C20 LFN 2004 (CAMA) as amended requires all companies, including banks, to prepare annual reports and accounts and that such (financial statements) must be audited by an auditor so appointed for that purpose. Such services is not gratuitous as the remuneration is also provided under the Act to be determined by the director (in the case of the auditor appointed by the directors) or by members at the annual general meeting or in such a manner as may be prescribed by the company. The Institute of Chartered Accountants of Nigeria (ICAN) recommends a scale for professional firms in determining fees charged for services rendered. However, in practice the actual amount paid or payable is ultimately a 'negotiated sum'. According to Gist (1992) auditors expect reasonable and sufficient fees to be paid to enable a satisfactory service to be provided. Although not clearly defined in any of the International Standards on Auditing (ISAs), the Nigerian Auditing Standards (NSAs), the IFAC Code of Ethics for Professional Accountants and the ICAN Scale of Professional Fees, the aspects regarding audit fees are extensively analyzed from the point of view of their effects on auditor's independence and audit quality. The audit fees can thus be simply described as the sums payable/paid to the auditor, for the audit services offered to the auditee (client). According to Simunic (1984), it is a reflection of economic cost of efficient auditors. In line with this, IFAC (2010) suggested that 'when entering into negotiations regarding professional services, a professional accountant in public practice may quote whatever fee that is deemed appropriate'. Similarly, the ICAN's Scale of Professional Fees while indicating that practitioners charge ridiculously inappropriate audit fees also affirm that a reasonably remunerated firm should deliver first class service for the needs of private sector clients, public sector clients, regulatory authorities and the general public.

Despite the copious scholarly works, there appears to still be growing concern on what is an appropriate audit fees and how do auditors determine such which is charged and is required to be paid or payable by the auditee. The clients (who demand the audit and other services) and the audit firms (who supply the audit and other services) are major players in the audit market. The overall structure of the audit market and the methodology for arriving at an appropriate audit fee is still on-going, especially in the developing economies where researches in this area are still scanty. Taffler and Ramalinggam (1982) in Baldacchino, Attard and Cassar (2014) argued that the manner in which audit fees are calculated differs from that of other professions where fees are directly or indirectly calculated on the monetary aspects of the business involved. Specifically,

Niemi (2005) confirmed that the basis on which audit fees is calculated is the number of hours to be worked on the engagement, multiplied by the rate per hour, and not any financial aspect of the subject matter. All of the above delineates the fact that audit fees and their determination might be seen as a black box by the stakeholders involved. No doubt, this makes the process a fairly complex task.

The seminal work by Simunic (1980) set the pace and provided the pathway for the extensive body of research, especially in developed countries of USA, UK, Australia, Canada and Germany, involving the examination of determinants of audit fees. He (Simunic) identified client's size, risk and complexities to be main determinants. Since then, there have been studies in this area with additional factors added. In spite of the mixed and inconsistencies in the reported results and findings of these empirical studies, effective factors capable of influencing audit fees have been agreed upon to be classified into client-specific attributes, auditor-specific attributes and audit environment (Hay, 2010). Furthermore, these studies have used some variant of the basic model by Simunic (1980) and have been skewed towards the adoption of static panel model. Aside from similar methodology being put into use, another common trend and pattern noticeable is the continuous exclusion of the financial sector. To this end, this study contributes to existing works in this area, specifically by extending empirical work through the adoption of a dynamic panel methodology in order to equally account for the dynamic nature of variables, need to consider endogeneity coupled with high persistence of the data, using deposit money banks in Nigeria.

Beside the introduction, this paper proceeds as follows. Section 2 reviews relevant literatures and section 3 is on methodology. While the empirical results and discussions are conducted and presented in section 4, section 5 concludes the study.

CONCEPTUAL REVIEW AND HYPOTHESES DEVELOPMENT

Prior researches on the factors influencing the magnitude of audit fees for entities abound in the literature. According to Hay (2010), the determinants of audit fees can be generally classified into three (3) major categories: clients'/ auditees' attributes (size, complexity, risk, profitability, leverage, liquidity, internal control, ownership, governance and industry), auditor attributes (quality, tenure and location) and engagement (or audit) attributes (report lag, busy season, audit problems and non-audit reporting). While the client attributes have been given great attention in most previous research, the other two categories were less prominent. Further discussion is provided below on specific variables studied in this work under the broad category.

Clients' Attributes

There are several organizational factors that have been identified in the literature capable of influencing audit fees. Each of these variables is discussed separately in the following subsections.

(a) Auditee's Size

The most consistent result in all previous research has been that of auditee's size which has been found to have been a significant explanatory variable in determining audit fees (Simon & Taylor, 2002; Chung and Narasimhan, 2002; Ezzamel, Gwilliam and Holland, 2002; Wilson, 2003; Matthews and Peel, 2003; Fields, Fraser and Wilkins, 2004; Yousef & Kamal, 2013; Akinpelu, Omolaja, Ogunseye and Bada, 2013; Soyemi & Olowookere, 2013; Ajide (2014); Soyemi (2014); Kikhia, 2015). Chung and Narasimhan (2002) in their international study on audit fees found that client size accounted for a major determinant in audit fees charged to organizations. Wilson (2003) using samples of energy firms also replicated the result that firm size is positively related to audit fee. In addition, a time-series analysis by Matthews and Peel (2003) using UK companies on the antecedents of audit fees found that corporate size was the major determinant of audit fees 100 years ago. In Nigeria, Soyemi & Olowookere (2013), Akinpelu, et al (2013) and Ajide (2014) studied determinants of audit fees among Nigerian banks and conclude on the significance of bank size as effective factor which influence audit fees.

There are various proxies that have been used in the literature as a measure of the auditee size. The two most prominent are total assets (Simunic, 1980 in Francis, 1984; Taylor and Baker, 1981 in Francis, 1984; Francis, 1984; Simon, 1985 in Simon and Francis, 1988; Simon and Francis, 1988; Butterworth and Houghton, 1995; Davis, et al., 1993; Firth, 1997) and sales (Ezzamel, et. al, 2002; Taffler and Ramalinggam, 1982 in Matthews and Peel, 2003). With respect to the banking industry, gross earnings were used by Soyemi & Olowookere (2013), while total assets were used by Akinpelu, et al (2013) and Ajide (2014) and Swanson (2008). This variable is studied in this study with regards to audit fees for quoted banks in Nigeria; hence the hypothesis is formulated thus:

Hypothesis One: Audit fees paid by Banks in Nigeria are positive and significantly associated with bank size.

b) Auditee's Complexity

Another major variable used in explaining the variance between audit fee charges was the client's complexity (Yi, & Dong, 2012).

This was variously measured using the number of subsidiaries (Butterworth and Houghton, 1995; Pong and Whittington, 1994; Davis et al., 1993; Wilson, 2003; Ezzamel et. al., 2002; Fields, Fraser and Wilkins, 2004; Soyemi & Olowookere (2013), Akinpelu, et al (2013) and Ajide (2014), the ratio of auditee's receivables and/or inventories to the auditee's total assets (Simunic, 1980 in Francis, 1984; Simon, 1995 in Simon and Francis, 1988; Firth, 1985 in Butterworth and Houghton, 1995; Francis and Stokes, 1986 in Francis and Simon, 1987; Simon and Francis, 1988; Simon and Taylor, 2002) and audit fee diversification (Simunic, 1980 in Francis, 1984; Chen, et al, 1993 in Chung and Narasimhan, 2002). This variable is as well studied in this study with regards to audit fees for quoted banks in Nigeria, it is operationalised using the total number of consolidated subsidiaries and branch networks; hence the hypothesis is formulated thus:

Hypothesis Two: Audit fees paid by Banks in Nigeria are positive and significantly associated with auditee complexities.

(c) Auditee's Risk

In most studies, there was also the variable of auditee's risk that plays a major role in the determination of audit fees (Che-Ahmad & Houghton, 1996; O'Sullivan, 2000; Karim and Moizer, 1996; Curry and Peel, 1998; Simon and Taylor, 2002 Fields, Fraser and Wilkins, 2004; Yousef & Kamal, 2013; Akinpelu, Omolaja, Ogunseye and Bada, 2013; Soyemi & Olowookere, 2013; Ajide, 2014). The profitability/ losses as reported by the client in their financial statements have since been used as proxies for representing the risk associated with the client. Consequently, enterprises that were making accounting losses could be expected to represent a higher risk thereby increasing the probable inability to pay the auditing firm their fees (Karim and Moizer, 1996). Walker and Casterella (2000) using data from over 3,000 companies in the United States, found that auditors are managing their exposure to audit risk based on the auditee's risk or auditee profitability by adjusting audit fees. However, Davis et al. (1993) used opinion type as a proxy for risk as it measured this variable in terms of the loss that will be incurred if an unqualified audit opinion is issued inappropriately. They further argue that this measure more closely reflects auditors' actual perception of risk but are aware that the assessment of risk in this manner is more subjective in nature compared to more quantitative measures. Soyemi & Olowookere (2013) adopted operational risk and credit risk proxied with efficiency and non performing loan ratios. Similar variables are also adopted in this study. Therefore, the third hypothesis evolves as follows:

Hypothesis Three: Audit fees paid by Banks in Nigeria are positive and significantly associated with auditee risk.

Auditors' Attributes

Auditor's Size and International Link

Karim and Moizer (1996) provided an explanation for this relationship as the Big Six have access to higher quality staff and use higher quality procedures and so are more likely to detect errors and omissions. They argued that because of the Big Six's size, they were also better able to withstand pressure from client company management and so are more likely to act in an independent fashion, which consequently, increases the confidence of their auditing quality. An alternative view was postulated by Klein and Leffler (1981) in Deis and Giroux (1996) that brand name development or reputation is very important for assessing audit quality and consequently, audit fees. This point was further emphasized by Simunic and Stein (1987) also in Deis and Giroux (1996) who argued that credibility of audit services with external financial statement users which is closely related to an auditor's reputation is among the antecedents of audit quality. A study on UK companies also found further support for auditor's size having a positive impact on audit fees (Ezzamel, et. al., 2002). This result is replicated using a set of New Zealand companies which showed that Big 5 were receiving fee premiums compared to non-Big 5 or obscure audit firms (Johnson, Walker, & Westergaard, 1995). Nevertheless, Willekens and Achmadi (2003) using Belgian data for small private cliental showed that there were no price premium charged by large auditing firms compared to smaller auditing firms. This result was also repeated using Korean listed companies whereby Big 6 auditors were found to be not different in audit quality compared to non-Big 6 auditing firms (Jeong, Jung and Lee, 2005).

In Nigeria, existence of pricing premium was found by Soyemi (2014) during a study of 20 quoted non-financial companies from 2009-2012 to the tune of 98%. This is opined to have been higher when compared to other developing and developed countries. This variable is also captured in this study. The fourth hypothesis is thus stated as follows:

Hypothesis Four: Audit fees paid by Banks in Nigeria are positive and significantly associated with auditor size.

METHODOLOGY

Data and Sample Selection

The study employed a balanced panel data which was obtained from fourteen (14) quoted commercial banks whose shares were as well listed and traded on the NSE. This sample size represents over 87% of the total

number of public quoted banks (population) as at December, 2013, and was purposively selected.

Model Specification

The dynamic panel model for this study is as stated below in equation 1.

$$\ln_af_{i,t} = \ln_af_{i,t-1} + \ln_ge_{i,t} + effr_{i,t} + nplr_{i,t} + tsubs_{i,t} + tbrhs_{i,t} + Big4_{i,t-1} + u_{i,t} \text{-----}$$

----1

- Where:
- $\ln_af_{i,t}$ = Natural log of total audit fees
 - $\ln_af_{i,t-1}$ = lag of natural log of total audit fees
 - $\ln_ge_{i,t}$ = Natural log of gross earnings
 - $effr_{i,t}$ = efficiency ratio
 - $nplr_{i,t}$ = non performing loan ratio
 - $tsubs_{i,t}$ = total number of consolidated subsidiaries
 - $tbrhs_{i,t}$ = total number of branches
 - $Big4_{i,t}$ = top four professional accounting firms
 - $u_{i,t}$ = error term

Furthermore, by decomposing the big4 variable into their constituent firms, equation 2 evolves as follows:

$$\ln_af_{i,t} = \ln_af_{i,t-1} + \ln_ge_{i,t} + effr_{i,t} + nplr_{i,t} + tsubs_{i,t} + tbrhs_{i,t} + dell_{i,t-1} + ey_{i,t-1} + kpmg_{i,t-1} + \varepsilon_{i,t} \text{-----}$$

-----2

The difference GMM as proposed by Arellano & Bond (1991) and the system GMM estimator as propounded by Arellano & Bover (1995) and Blundell & Bond (1998) are adopted to estimate separately equations 1 and 2 as stated above. However, despite the dynamic perspective of this study and by extension the basis upon which the methodology is based, the static panel model comprising pooled, fixed and random estimates are as well conducted and presented alongside with that of the difference and system GMMs.

RESULTS AND DISCUSSIONS

Descriptive Statistics

Table 1a shows the summary of the descriptive statistics for the variables under study from 2006 – 2013 in this study for all the sampled banks while Table 1b shows the summaries for the audit engagements categorized in accordance with the audit firms.

Table 1a: Summary of the Descriptive Statistics

	Af	Ge	Effr	Nplr	tsubs	tbrhs
N	112	112	112	112	112	112
Minimum	17000	10965	14.50	1.10	0	41
Maximum	284000	360345	111.90	88.00	24	777
Mean	95912.4 3	87268.27	48.0582	15.4439	6.84	262.92
Std. Deviation	56334.4 20	66998.81 0	14.5778 0	18.8281 7	4.86 7	178.02 6

Source: Author Computation (using stata), 2015.

During this period, Table 1 showed a mean value of total audit fees for the 14 sampled banks as N95912.43 which ranged from N17million to N284million with a standard deviation of N56334.42. It is also evidenced from the table that there are considerable differences in the explanatory variables allowing for enough variations to run the estimates for the regression analysis. Bank size proxied by gross earnings range from N10965million to N360345million with a mean value of N87268.27million and a standard deviation of N66998.81. Bank risk proxied with efficiency risk ranges from 14.50% to 111.90% with a mean value of 48.06% and a standard deviation of 14.58 while credit risk (nplr) varies from 1.10% to 88% with a mean value of 15.44% (higher than the CBN regulatory ratio of 10%- prior to 2010 and 5%- from 2011) and a standard deviation of 18.83. Lastly, bank complexities measured by the total number of consolidated subsidiaries ranged from 0 to 24 with a mean value of 7 and a standard deviation of 4.87. The total number of branch networks on average is 263 with a standard deviation of 178.03. It ranged from 41 to 777.

The breakdown according to the audit firms is further provided in table 1b. All the sampled banks were audited by the top four audit firms (otherwise known as the 'big4') except for unity bank which hired Panell Kester Foster and A. Zakari & Co as their auditors for years 2009-2010 and 2011-2013 respectively. From the table, this translates to 96% of the total sampled banks, accounting for N11, 869, 179 of the total audit fees of N12, 366, 948 accruable during the period. The remaining balance of N497,769 representing 4% is shared by the duo of Panell Kester Foster and A. Zakari & Co, being the two indigenous audit firms engaged by unity bank. Besides, among the top four audit firms appointed during the period, PwC came top in terms of the number of audit engagements, being 35.81% amounting to N4,428,392 following closely by KPMG with N3,976,287 representing 32%. AWD has 18% amounting to N2,238,500 while E&Y has 10% (approx.) amounting to N1,226,000.

Table 1b: Total Audit Engagements by Audit Firms

Audit firms	Number of audit Engagements	Audit Fees (N'000)	%
AkintolaWilliams Delloite (AWD)	27	2,238,500	18.10
Ernst & Young (EY)	12	1,226,000	9.91
KPMG	34	3,976,287	32.15
PricewaterCoopers (PwC)	34	4,428,392	35.81
Others	5	497,769	4.03
Total	112	12,366,948	100.00

Source: Author Computation, 2015.

Correlation Analysis

Table 1c summarizes the results of preliminary correlation analyses among the variables. The need for the computation of the correlation coefficients among the variables was borne out of two important purposes. First is to determine whether there are bivariate relationship between each pair of the dependent and independent variables. The second is to ensure that the correlations among the explanatory variables are not so high to the extent of posing multicollinearity problems, which might cause estimation problems.

Table 1c: Pearson Correlation Matrix among Studied Variables

Variables	In_af	In_ge	Effr	nplr	tsubs	Tbrhs	big4
In_af	1						
In_ge	.789**	1					
Effr	-.130	-.326**	1				
Nplr	-.292**	-.454**	.459**	1			
Tsubs	.477**	.587**	.009	-.201*	1		
Tbrhs	.452**	.677**	.014	-.207*	.590**	1	
big4	-.034	.062	-.189	-.014	.025	.044	1

Source: Author Computation (using stata), 2015.

As shown, bank size proxied with gross earnings (0.789), total number of branches (0.452) and total consolidated subsidiaries (0.477) are positive and significantly related to audit fees. On the other hand, efficiency ratio (-0.130), auditor size (-0.034) and credit risk, that is, non performing loan ratio (-0.292) are negatively related to audit fees with only the latter showing a significant association. In all, the table provides no evidence of multicollinearity problems, hence, regression estimation is then attempted.

Regression Results

Table 2a depicts the results of the estimated model, both static and dynamic estimation techniques. The former has always been the estimation methodology for most researches in this area while the latter is the modus operandi for this study. Furthermore, table 2b provides the diagnostics for each of the estimation techniques.

Table 2a: Estimates for Regression Analysis

Variables	Pooled	Fixed	Random	Diff. GMM	Sys. GMM
ln_af_L1	-	-	-	0.385**	0.481***
ln_ge	0.747***	0.823***	0.820***	0.149**	0.449***
effr.	0.007**	0.011***	0.009***	0.006	0.004
nplr	0.001	0.001	0.002	0.005*	0.005**
tsubs	0.005***	0.004	0.003	-0.019	-0.029**
tbrhs	-0.001	0.001	-0.000	0.001	0.000
big4	-0.161	0.398*	0.110	0.158	0.028
constant	3.003	1.076	1.731	1.046	0.798

*** @1%; ** @5%; *@10%

Source: Author Computation (using stata), 2015.

The results for the static model showed that there exists a positive relationship between bank size, risk, complexity (except total number of branches that displayed a negative for pooled and random), auditor's size (except for pooled) and audit fees. As regard the F-statistics test, the explanatory variables are jointly and statistically significant in the three estimated models of pooled (31.22), fixed (56.51) and random (251.71). The adjusted R-square showed that the explanatory variables jointly accounted for 65%, 81% and 79% variations in audit fees respectively.

Based on the L-M test statistics, χ^2 (1) of 13.16 (0.0003), adopted to compare between the pooled and the random regression estimates, we do not accept the null hypothesis rather the alternative hypothesis is accepted implying that the individual specific effect is not equal to zero, therefore we do not reject the random effect. However, using the Hausman specification test to select between fixed and random effects, the test value of 44.25 ($P < 0.01$) do not accept the null hypothesis that differences in coefficients are not systematic, therefore we accept the alternative hypothesis and conclude that the differences in coefficients are systematic. Based on this, we accept and interpret the fixed effect model estimate.

Table 2b: Estimates for Regression Analysis (big4 decomposed)

Variables	Pooled	Fixed	Random	Diff. GMM	Sys. GMM
ln_af_L1	-	-	-	0.402***	0.490***

In_ge	0.723***	0.800***	0.786***	0.464***	0.435***
effr.	0.006	0.127***	0.007**	0.005	0.004
Nplr	0.003	0.003	0.003	0.005**	0.005**
Tsubs	0.004	0.008	0.003	-0.020	-0.030
Tbrhs	-0.001	0.001	0.000	0.001	0.000
Dell	-0.202**	0.088	-0.104	0.523	0.558
Ey	0.158	0.075	0.154	0.049	0.065
Kpmg	-0.021	-0.140	-0.024	0.013	0.045
Constant	3.117	1.577	2.311	1.293	0.851

*** @1%; ** @5%; *@10%

Source: Author Computation (using stata), 2015.

Table 3: Results of Diagnostics

	Pooled	Fixed	Random	Diff. GMM	Sys. GMM
No. of Obs.	112	112	112	70	84
F-statistics/ Wald chi ²	31.22***	56.51***	251.71***	230.48**	250.52**
Adj. R ²	0.65	0.81	0.79	-	-
L-M Statistics	13.16***			-	-
Hausman test	44.25***			-	-
No. of Instruments	-	-	-	22	27
Sargan test	-	-	-	16.90	18.17

*** @1%; ** @5%; *@10%

Source: Author Computation (using stata), 2015.

This translates to mean that while the studied variables displayed positive relationships, only bank size (gross earnings, 0.823), risk (efficiency ratio, 0.011) and auditors size (0.398) are significantly related to audit fees. Therefore, audit fee will increase by 0.823% and 0.011% given a percentage increase in gross earnings and efficiency ratio respectively. Also, there is an indication of the existence of a pricing premium of approximately 40% owing to the engagement of the top four audit firms in the banking industry. This pricing premium is seen to be a generalized one, rather than accruing to any of the firms, as none of the coefficients for any of the big4 are significant; hence, there are no pricing differentials among these top four audit firm.

Table 2a also presents estimates for the difference and system GMM, both being dynamic panel model. The results for the difference GMM shows a positive and significant association between the immediate (lag) audit fees paid by banks, gross earnings and the non performing loan ratio. This is similar to that of the system GMM, except that the total number of consolidated subsidiaries (tsubs) is added as it also displayed a significant and positive relationship. However, there is no indication of a pricing

premium. In addition, the Sargan test of 16.90 (p-value of 0.2614) and 18.17 (p-value of 0.5113) coupled with the number of instruments of 22 and 27 for the difference and system GMM respectively. Being insignificant, as evidenced by the p-values for the null hypothesis of the overidentifying restrictions, we therefore, in all specifications, do not reject the null hypothesis.

Overall, findings from this study tallies with previous studies both in the developed economies [Chen, et al (1993), Pong & Whittington (1994), Che Ahmad & Houghton (1996), Baldacchino, Attard, Cassar (2014), Wong (2009)] and emerging economies [Simon and Taylor, (2002), DeFond and Francis (2005), Firer and Swartz (2006), Yousef & Kamal, (2013), Soyemi & Olowookere (2013), Soyemi (2014), Kikhia (2015)]. A major addition is the influence of past amounts paid as external audit remunerations to bank auditors. This is also seen to be significant for both the difference and system GMM, thereby justifying the need to factor in past audit fees in the consideration of effective factors capable of influencing external audit fees.

CONCLUSIONS

In the examination of effective factors capable of influencing fees paid by banks to their auditors, there is the need to account for the dynamic nature and the high persistence of the data. Many past empirical studies have excluded this important element, thereby limiting the econometric methodology to the static panel model. Though, it is short run oriented but definitely an improvement to the trio of pooled, fixed and random OLS estimation techniques.

REFERENCES

- American Accounting Association (1973). 'Statement of Basic Auditing Concepts'. AAA Publications.
- Anderson, T. and Zeghal, D. (1994). 'The Pricing of Audit Services: Further Evidence From the Canadian Market'. *Accounting and Business Research*. Vol. 24(95), 195-207.
- Ajide, F.M. (2014). 'Audit Pricing in Nigerian Banking Industry: A panel Analysis (2008-2012)'. *IOSR Journal of Economics and Finance*. Vol. 2 (6), pp. 26- 34.
- Basioudis, I.G., and Fifi, F. (2004). 'The Market for Professional Services in Indonesia'. *International Journal of Auditing*. 8 (2), 153–164.

- Butterworth, S., and Houghton, K. A. (1995). 'Auditor switching: The Pricing of Audit Services'. *Journal of Business Finance and Accounting*. 22(3), 323-344.
- Chen, P., Ezzamel, M. and Giwilliam, D. (1993). 'Determinants of Audit Fees for Quoted UK Companies'. *Journal of Business Finance and Accounting*. Vol. 20(6), 765-786.
- Che-Ahmad, A., and Houghton K. A. (1996). 'Audit Fee Premiums of Big Eight firms: Evidence from the Market for Medium-Size UK Auditees'. *International Accounting, Auditing & Taxation Journal*. No. 5, 53-67.
- Curry, B. and Peel, M. J. (1998). 'Neutral Networks and Business Forecasting: An Application to Cross-Sectional Audit Fee Data'. *International Journal of Commerce and Management*, Vol. 8(2), 94 – 120.
- Chung, S. and Narasimhan, R. (2002). 'An International Study of Cross-Sectional Variations in Audit Fees'. *International Journal of Auditing*, 6(1), 79-91.
- Davis L. R., David N. R. and Trompeter, G. (1993). 'Audit Effort, Audit Fees, and the Provision of Non-audit Services to Audit Clients'. *The Accounting Review*, 68 (1), 135-150.
- Deis, D. and Giroux, G. (1996). 'The Effect of Auditor Changes on Audit Fees, Audit Hours, and Audit Quality'. *Journal of Accounting & Public policy*, Spring 1, 55-76.
- Ezzamel M., Gwilliam D.R., Holland K.M. (2002). 'The Relationship between Categories of Non-Audit Services and Audit Fees: Evidence from UK Companies'. *International Journal of Auditing*, 6 (1), 13-35.
- Fields, E., Donald, F. and Williams, M. (2004). 'An investigation of pricing of audit services for financial institutions'. *Journal of Accounting and Public Policy*, 23(6), 53 – 77.
- Firer, S. and Swartz, N. (2007). 'The Market for Audit Services in the 'New" South Africa'. *Southern African Business Review*, Vol. 11 (1), 45-64.
- Firth, M. (1997). 'The Provision of Non-Audit Services and the Pricing of Audit Fees. *Journal of Business Finance and Accounting*'. Vol. 24(3) and (4), 511-525.

- Firth, M. (1985). 'An Analysis of Audit Fees and their Determinants in New Zealand'. *Auditing: A Journal of Practice and Theory*, Vol. 4(2), 23-37.
- Francis, J. R. (1984). 'The Effect of Audit Firm Size on Audit Prices: A Study of the Australian Market'. *Journal of Accounting and Economics*, 6, 133-151.
- Francis, J. R. Stokes, D. J. (1986). Audit Prices, Product Differentiation, and Scale Economies: Further Evidence from the Australian Market. *Journal of Accounting Research*, Vol. 24(2), 383-393.
- Francis, J.R. and Simon, D.T. (1987). 'A Test of Audit Pricing in the Small –Client Segment of the U.S. Audit Market'. *Accounting Review*, 62, 145-157.
- Gonthier-besacier, N and Schatt, A. (2006). 'Determinants of Audit Fees for French Quoted Firms'. *Managerial Auditing Journal*, Vol. 22(2), 139-160.
- Gul, F.A. (1999). 'Audit Prices, Product Differentiation and Economic Equilibrium'. *Auditing: A Journal of Practice and Theory*. Vol. 18(1),90-100.
- Hay D. (2010). 'The Accumulated Weight of Evidence in Audit Fee Research: Further Steps in Meta-Analysis'. Ebookbrowse.com/the-accumulated-weight-of-evidence-in-audit-fee-research-further-steps-in-meta-analysis-pdf-d197393478.
- Ho, S.W.M. and Ng, P.Y.H. (1996). 'The Determinants of Audit Fees in Hong Kong: An Empirical Analysis'. *Asian Review of Accounting*. Vol. 4(2), 32-50.
- Joshi, P. L., Al-Bastaki, H. (2000). 'Determinants of Audit Fees: Evidence from the Companies Listed in Bahrain'. *International Journal of Auditing*, Vol. 4(2), 129-138.
- Karim, A. and Moizer, A. (1996). 'Determinants of Audit Fees in Bangladesh'. *International Journal of Accounting*. 31, 497-509.
- Khani, H. and Yazdani, Q. A. (2012). 'Effective Factors on Determinants of Audit Fees in Iran'. *Research Journal of Recent Sciences*, 1(6), 38-44.
- Kikhia, H. Y. (2015). 'Determinants of Audit Fees: Evidence from Jordan'. *Accounting and finance Research*, Vol. 4(1), 42-53.

- Matthews, D., and Peel, M. J. (2003). "Audit fee determinants and the large auditor premium in 1900." *Accounting and Business Research*. 33 (2): 137-155.
- O'Sullivan, N. (2000). 'The Impact of Board Composition and Ownership on Audit Quality: Evidence from Large UK Companies'. *British Accounting Review*, 32, 397–414.
- Pong, C. M. and Whittington, G. (1994). 'The Determinants of Audit Fees: Some Empirical Models'. *Journal of Business Finance and Accounting*, Vol. 21(8), 1071-1095.
- Shammari, B. A., Yaqout, A. A. and Hussaini, A. A. (2008). 'Determinants of Audit Fees in Kuwait'. *Journal of Academy of Business and Economics*, 8(1).
- Simon D. and Taylor M. (2002). 'A Survey of Audit Pricing in Ireland'. *International Journal of Auditing*, Vol. 6(1), 1-12.
- Simon, D. T. and Francis, J. R. (1988). 'The Effects of Auditor Change on Audit Fees: Test of Price Cutting and Price Recovery'. *The Accounting Review*, Vol. LXIII(2), 255-269.
- Simon, D.T. (1995). 'The Market for Audit Services in South Africa'. *International Journal of Accounting Education and Research*, Vol. 30, 356–365.
- Simunic, D. A. (1980). 'The Pricing of Audit Services: Theory and Evidence'. *Journal of Accounting Research* 22 (3), 161-190.
- Simunic, D. and Stein, M. (1996). 'The Impact of Litigation Risk on Audit Pricing: A Review of the Economic and the Evidence'. *A Journal of Practice and Theory*, Vol. 15, 19-34.
- Soyemi, K. A. and Olowookere, J. K. (2013). 'Determinants of External Audit Fees: Evidence from the Banking Sector in Nigeria'. *Research Journal of Finance and Accounting*, Vol. 4(15), pp. 50-58.
- Soyemi, K. A. (2014). 'Clients'/Auditors' Attributes and External Audit Fees among Listed Non-Financial Companies in Nigeria'. *The Business & Management Review*, Vol. 5(1), pp. 131-140.
- Soyemi, K. A. (2015). Determinants of Audit Fees among Deposit Money Banks in Nigeria. Unpublished PhD Thesis in the Department of Management and Accounting, Obafemi Awolowo University, Ile Ife.

- Swanson, K. (2008). 'The Determinants of Audit Prices for Financial Services Institutions in the United States'. *Major Themes in Economics Spring*.
- Taffler R. J. and Ramalingam, K. S. (1982). 'The Determinants of Audit Fees in the UK: An Exploratory Study'. City University Business School, *Working Paper* No. 37, London.
- Taylor M. E., Baker. R. L. (1981). 'An Analysis of the External Audit Fee'. *Accounting and Business Research*, Vol. 12(45), 55-60.
- Taylor, M. and Simon, D. (2003). 'The Market for Audit Services in Nigeria'. *Research in Accounting in Emerging Economies*.
- Walker, P. L. and Casterella, J. R. (2000). 'The Role of Auditee Profitability in Pricing New Audit Engagements". *Auditing: A Journal of Practice and Theory*, Vol. 19, 157–67.
- Wong, S. (2009). 'Audit Pricing In Australia In 2000s'. *International Review of Business Research Papers*, Vol. 5(3), 82-89.
- Yousef, M. H. and Kamal, N. (2013). 'Determinants of Audit Fees: Evidence from an Emerging Economy'. *International Business Research*, Vol. 6(8), 13-25.
- Yi, Z. and Dong, Y. (2012). 'A Comparative Analysis of the Effect Factors of Audit Pricing in a Share 'Three Boards' Market'. *Journal of Modern Accounting and Auditing*. Vol. 8(7), 967-974.

THE EFFECT OF REGULATORY FRAMEWORK ON AUDITORS' INDEPENDENCE IN NIGERIA.

WRIGHT, Olatunde

Department of Accounting,
Faculty of Social and Management Sciences,
Bowen University, Iwo

ABSTRACT

This study examined the influence of regulatory framework on auditors' independence in Nigeria. It examined whether auditors' comply with the provision of Companies and Allied Matters Act (2004) and other relevant regulatory framework, it also assessed whether quoted companies in Nigeria disclose separately non audit services (NAS) in their financial statements with a view to determining whether the auditors comply with the provision of the law.

The study adopted both primary and secondary data collection methods. Primary data was obtained through questionnaire purposively administered to 300 respondents while secondary data was obtained through the annual financial records of 33 companies selected. The study had the following findings: NAS provided by auditors may impair auditors' independence; long tenure brings about familiarity that can impair the independence of auditors; shareholders rather than managers should determine auditors' fees and that many regulators do not possess legislative power to sanction. The study concluded that; while auditors may be allowed to carry out NAS for their audit clients, such assignments must be pre – approved by the audit committee; and that separate personnel rather than the audit staff should be used to carry out NAS.

Key Words: *Non Audit Service, Financial Reporting, Regulatory Frameworks. Reporting Standards.*

INTRODUCTION

Financial statements of companies are its bill of health; the document is crucial and important not only to the shareholders but to other stakeholders.

The Companies Act 1968 was the first Nigerian Companies Act to make mandatory provision in respect of the form of financial statements. Before then, keeping of proper accounts and publication of such were made under United Kingdom Companies Act of 1948. These have been

expanded under Companies and Allied Matters Act 2004 which is also largely based on the United Kingdom Companies Act 1985 (Orojo 1992).

The need for auditing come as a result of the separation of ownership from the day to day running of the business, managers are appointed to run the activities of companies, the only document to explain the company's current position and past financial performance are the financial statements. Jensen and Meckling (1976) stated that Auditing is one of the tools that can be used to monitor the activities of the firm as well as the value of the firm.

The word auditing is derived from the Latin word "AUDIRE" meaning "he hears". This word finds its origin in the ancient times, when the accounts of estate, domain or manor were checked by having them called out to government officials by those who had compiled them. (Woolf 1997, Aderibigbe 1997).

In Nigeria, the principal legal framework that regulates the activities of company's audit is Companies and Allied Matters Act 2004, followed by International Standards on Auditing (ISA). Other regulators include Financial Reporting Council of Nigeria (FRCN) through International Financial Reporting Standards, Corporate Affairs Commission, Securities and Exchange Commission, Central Bank of Nigeria, The Institute of Chartered Accountants of Nigeria (ICAN), and Association of National Accountants of Nigeria (ANAN) among others.

The not too long corporate failures all over have caused stakeholders to doubt if auditors are indeed independent of the management they are to check.

STATEMENT OF THE PROBLEM

Due to the scandals, the investor's confidence globally in the capital market has weaned, much concern has been on accounting and auditing practices and particularly on the independence of the auditor, (Sulton 2002).

It is difficult in Nigeria to determine in most cases the amount companies pays auditors on NAS because almost all companies fail to disclose separately fees paid to auditors on NAS in their financial statement.

Auditors are not in most cases seen to act independently of management, as a result the audit process seems to have lost its value. Without reliable and standard audit, the report would not be credible; also investors and creditors would have little or no confidence in it.

There is the problem of who actually determines audit fees, does non – audit services (NAS) and audit tenure impairs auditor's independence.

The present SEC code of Corporate Governance on auditor's tenure affect companies listed on the stock exchange only while private limited liability companies are left alone.

The purpose of this study is to contribute to the debate on the influence of the Companies and Allied Matters (Act 2004) and other relevant regulatory framework on auditors' independence, the study would also examine the extent to which listed companies in Nigeria disclose non – audit services (NAS) attempt would also be made to know whether audit tenure actually affect auditors' independence and on a final note the study would also determine whether who determine audit fees affect auditors' independence.

RESEARCH QUESTIONS

The study intends to address the following questions.

1. to what extent do auditors comply with the provision of CAMA (2004) and their professional regulations?
2. to what extent do quoted companies in Nigeria disclose non audit services payment in the financial records?
3. do auditors tenure actually affect the auditors' independence?
4. does who determines audit fees affect auditor Independence?

OBJECTIVES OF THE STUDY

The broad objective of this study is to investigate what effect regulatory framework has on auditor's independence in Nigeria. The specific objectives of the study are to:

- i. examine whether auditors comply with the provision Companies and Allied Matters Act 2004 and other relevant regulatory framework;
- ii. assess whether quoted companies in Nigeria disclose separately non audit services payment in their financial records;
- iii. examine whether audit tenure affects the auditors' independence: and
- iv. examine shareholder's role in ensuring auditor independence.

RESEARCH HYPOTHESES

To be able to provide answer to the research questions raised, two testable hypotheses would be tested in their null forms.

- (1) H_{01} : The Provision of non-audit services by auditors and auditor's tenure do not significantly impair auditor's independence.
 H_{11} : The Provision of non-audit services by auditors and auditor's tenure do significantly impair auditor's independence.

- (2) H₀₂: The audit regulatory framework does not have significant impact on auditors' independence.
H₁₂: The audit regulatory framework has significant impact on auditors Independence.

JUSTIFICATION FOR THE STUDY

As a result of the significance of financial statements to the investing public and other users, it is evident that the issue of whether provision of non – audit service as well as audit tenure impair the independence of auditors have continue to generate interest of researchers to study the nature of auditors independence and if non – audit services and audit tenure can impair their independence. And if the present regulatory frameworks in place are stringent enough to ensure that auditor's are independent. It should be noted that event of the recent past has shown that despite the attempt to ensure the independence of auditors, the reverse continue to be the case.

The users of financial records need to be sure that the reports provided by auditors shows the true and fair view of the state of affairs of companies. Auditors should approach their work strictly so as to make sure that it is free from any manipulation of the management. The importance of this study can be viewed from the fact that there cannot be a better time than now when investing public are worried about the extent of assurance they have on audit report.

The study of regulatory framework in Nigeria in respect of accounting and auditing practices is very important since the frameworks are the bed rock of any capital market. For reliable audit these frameworks must be in place without which the corporate world will be in chaos. Auditors must also adhere to the tenet of the framework in order to be able to provide quality work.

This study is intended to contribute to the debate on auditors' independence by exploring, first the present regulatory framework in Nigeria on auditor's independence, secondly by providing evidence that non – audit service and audit tenure does not impair auditor's independence, the concerns raised by the regulators, academia and financial press as well as investing public regarding the role played by non – audit services are justified only when the audit tenure is short. Third, in support of earlier findings that longer audit tenure does not lead to impairment of audit report quality and auditors independence. Myers et al. 2003 suggested that the system of voluntary auditors' rotation, which results in shorter audit tenure, is linked to poor audit quality when non – audit fees are large. The findings would go a long way to put all the

stakeholders of financial reports at rest and thereby help them to place much more confidence on the financial reports produced by the external auditors.

SCOPE OF THE STUDY

The principal regulatory framework on the performance of audit of financial statements in Nigeria is the Companies and Allied Matters Act 2004(CAMA) and the recently adopted International Financial Reporting Standards, it is the aim of this research work to focus on issues in the Companies and Allied Matters Act 2004 as regards the independence of Auditors'. The study covers a period of ten (10) years (i.e 2000 -2009).

LITERATURE REVIEW

Financial reporting quality is a basic ingredient to enhance the credibility of financial statement produced by external auditors to the report. (Rohami, etal. 2009)

Conceptual Literature Review

The CAMA (2004) requires that the auditor of a company to state whether in his opinion the financial statements disclose a true and fair view of the state of company's affairs. An auditor should prove himself to be an independent person and must not compromise his position. His reports lend credibility to the financial information upon which reliance can be placed by the users of financial statements.

The Council of American Institute of Certified Public Accountants (AICPA) (1947) expressed that independence, both historically and philosophically, is the foundation of the public accounting profession and upon its maintenance depends the profession's strength and its stature. John L Carrey (1970) described independence as a state of mind and a matter of character. It is ability to avoid biases; and integrity; willingness to report a truthful opinion that reflects the matter discovered during audit. Carey and Doherty in their own study define Independence as avoidance of situation which would tend to impair objectivity or permit personal bias to influence delicate judgment. They concluded that independence cannot be define with precision, it is primarily a condition of mind and character. While Dopuch and Sunder (1980) opined that definition no matter how carefully worded cannot bear the burden of the struggle for economic advantage between various interest groups. Auditors' independence in its most general form allows external auditors to reduce agency cost between corporate managers and shareholders (Ng. 2003, Watts and Zimmerman 1983).

Auditors independence is one of the area that continue to attract attention of every stakeholders because it is an area that is consistently vulnerable

to manipulation (Humphrey, Moizer and Turley, 1993). Auditors should be free from those pressures and other factors that compromise or can be reasonably perceived to compromise its ability to realize unbiased audit decision (Alleyne et. Al. 2006). The importance of auditors' independence cannot be over emphasized because it is important to both the general public and the profession. Since management of the business is not always in the hands of shareholders, the only source through which they can be sure that managers of their business is not manipulating records of the company is the auditors, while it represent public stewardship and professional status (Kleinman and Palmmon, 2001). Gill, Cosserat, Leung and Coram 2001 stated that "independence is the cornerstone of the auditing profession and without independence the auditor opinion is suspect". In general, there are two types of auditors' independence: independence "in-fact" and independence-"in appearance". Dykxhoom and Sinning, (1982) define independence in-fact as the auditors' abilities to make objective and unbiased audit decision. On the other hand independence-in-appearance refers to the financial users' perceptions of the auditors' independence.

Olagunju (2011) in his own work provide that the independence of an auditor affects the credibility of the financial statement. Ebimobowei (2011) examines the adequacy of independence of auditors and determines whether or not the provision of non-audit services affect the independence of auditors. In his findings, he reported that the prohibition of non-audit service by auditors to the same client does not solve the problem of corporate failure rather; there should be improved disclosure, transparency and governance around the subject of non-audit fees, policies and procedures.

Adeyemi and Akinniyi (2011), reported that the size of audit fee is the most influencing factor capable of deterring auditors' independence in Nigeria. Their findings also proposed that the existing laws were obsolete and hence the need to update them so as to make them relevant.

Oladipupo and Izedonmi (2011) examine the relationship between the audit fees and nature of audit reports, and reported that the higher the audit fee the lower the auditor independence and the higher the incidence of issuing unqualified audit reports.

Auditors' independence according to Johnstone, Sutton, and Warfield (2001) classified factors and activities that create threats, or risk, to auditor independence as direct and indirect factors.

Factors That May Impair Auditors Independence.

The Independence Standard Board (ISB) (1997) Outline five types of threat that may impair the independence of an auditor. They are as follows

- i. Auditors acting for their own interest;
- ii. Peer review of audit work;
- iii. Auditors participation in management;
- iv. Personal relationship with client (family); and
- v. Direct or indirect pressure from stakeholders.

Jeppeson (1998) supported Mantz and Sharaf (1961) by stating these other three ways in which the auditor's independence must manifest itself:

- a) Programming independence
- b) Investigative independence
- c) Reporting independence

Programming Independence

This helps auditors to select the most appropriate strategy with which to conduct an audit assignment. Auditors must approach the job with whatever manner they considered best. Additionally audit profession is a dynamic one, with new techniques constantly being developed and upgraded which the auditors may decide to use.

Investigative Independence

This is the freedom given to auditors to implement the work with the strategies in the manner they considered necessary. Auditors must have unlimited access to the company's records. Client must respond to all queries regarding the company's business and accountability treatment.

Reporting Independence

Here auditors must be free to choose to disclose to the public any information they believe should be disclosed. The audit opinion of the auditor should not be influenced by anybody.

The audit failures have led to major criticism of auditing profession worldwide by exposing the weakness of the profession in terms of safeguarding shareholders and stakeholder's interests. (Brandon et al 2004, Citron 2003; Krishnan, 2005).

The importance of this issue is mainly due to audit failures and financial scandals worldwide. Those events began with Enron Scandal (Hilzenrath, 2001) which led to the downfall of audit firm Andersen which extends to WorldCom (Pulliam and Blumenstein, 2003) as well as other scandals.

Controversy over auditors' independence also existed before the Enron Scandal when observers noted that fees charged by auditors for non-audit services to their clients were growing rapidly.

Auditor's Tenure and Auditors Independence

As earlier mentioned, auditors have been blamed due to their role in the mega Corporate Scandals such as Enron, WorldCom and in Nigeria Cadbury, African Petroleum, etc. There have been a lot of arguments that auditors are compromising their independence due to the fact that they audit their client for a long time, this has been a subject of debate in the United State. It has been said that such a long-term relationship could, in reality or be perceived to, make the audit firm too committed or beholden to the companies thereby undermining its independence, compromising its objectivity and reduce effectiveness (Auditing Profession, 2002).

In contrast to the argument supporting shorter auditor tenure, the other school of thought submitted that impairment of auditor's independence may be greater during the first few years of an auditor client relationship, (Geiger and Raphmandan 2002, Gul et.al 2005, Myers et al 2003). Again it was opined that shorter tenure is associated with lower audit quality because the auditors is unfamiliar with the clients accounting system and firm characteristics. Failures occur almost three times more often when audit firm performs its first or second audit of a given client. (Myers et al (2003) findings in their study also provide support for this argument by documentary lower earring quality for clients with shorter auditors' tenure. Based on the evidences related to shorter audit tenure, the study considered that the desire to maintain client in the early year of engagement could cause the auditor to be more accommodating to the client. As a result of the long tenure, the auditor will have a better understanding of the client's accounting system and be in a better position to detect any misstatement by the management.

Non-Audit Service and Audit Quality

Non Audit Services may be define as any services provided by an auditor to his audit clients apart from the audit services.

There are marked-based incentives for auditors to remain independent; there are also forces that threaten auditor independence. Specifically, regulators are concerned about two effect of non-audit services.

- i. The fear that non-audit service fees make auditors financially dependent on their clients, as such they are not willing to stand up to management pressure for fear of losing their business.

- ii. Consulting nature of many non-audit services put auditors in managerial roles, hence their objectivity about the transaction they audit is threatened. (SEC. 2000).

According to CAMA Section 358(2a), auditors are disqualified from providing professional advice in a consultancy capacity to their audit clients in respect of Secretariat, Taxation and Financial management.

Regulators' are concerned that auditors would become financially dependent on their client when they consider the benefits they are likely to gain from retaining clients that pay large non-audit service fees outweigh the expected cost of sacrificed independence. This argument is based on the assumption that non-audit service fees include economic rents; otherwise, auditors will be indifferent between keeping and losing their non-audit service.

It is however noticed that auditors still accept the consultancy services in other name apart from that of the audit service name.

The existing studies on the association of NAS and auditors independence have evaluated whether higher NAS fees create an economic bond between the auditor and the client, which enables the client firm to exert influence over the auditor.

The proponents of joint provision of audit and NAS contended that auditor independence would not be affected because it would improve audit quality. Also, it was claimed that the auditors knowledge of clients company would be improved by the provision of NAS, which it is believed that would result into increased objectivity (knowledge Spillover) and independence (Goldman and Barler, 1974; Wallman 1997. The joint provision of audit and NAS would create 'economies of scope'; Arrunada (1997, p. 165) pointed out that joint provision of audit and NAS would reduce overall costs, raises the technical quality of auditing, enhance competition, and need not prejudice auditor independence or the quality of non-audit services, which would ultimately increase auditor independence (Goldman and Barlev, 1974; Wallman 1996).

Opponents to the joint provision of audit and NAS claimed that auditors would not perform their audit services objectively and that joint provision would impair perceived independence (Brandon et al., 2004; Frankel et al., 2002; Jenkins and Krawczyk, 2001; Lowe and Pany, 1995; Raghunandan, 2003; Wines, 1994) because ultimately they would be auditing their own work or acting as management (SEC, 2001), and management's power over the auditor could be increased due to auditors' reliance on fees received. Thus, it may influence "their mental attitude, impartiality and objectivity, and independence of thought and action"

(Flint, 1988, p. 82).

As an alternative to a total ban on provision of NAS to audit clients, Arrunada (1997) recommended the use of different divisions are responsible for each series of services as a safeguard to independence. These divisions are organized as profit centres within audit firms that have their own management and exert little if any influence over the audit partners' evaluation or compensation process. In fact, the idea is justifiable in the UK environment, where Lennox (1999) found a weakly positives significant association between audit qualifications and disclosed NAS and construed that the 'current UK policy may be justified in not banning NAS. This conclusion is strengthened if policy-makers take account of the economies of scope that may accrue from allowing the joint provision of audit and NAS'.

The potential threat to auditor independence is lessened when there is a separation of personnel performing NAS and audit services (Pany and Reckers, 1984). Similarly, Lowe and Pany (1995) and Swanger and Chewing (2001) discovered significant positive associations between auditor independence and joint provision of NAS by staff separation (segregation of duties). However, Quick and Warming- Rasmussen (2005) found that joint provision of audit and NAS by staff from separate departments did not improve perceived independence.

Theoretical Framework

There are so many theoretical frameworks that explain the demands for audit service, among these theories are.

- (i) The Agency Theory;
- (ii) The Inspired Confidence Theory;
- (iii) The Policeman Theory; and
- (iv) Lending Credibility theory.

The study centered on the agency theory, because the theory goes a long way to the root of the need for external audit.

This theory influences how the hypothesis was to be formulated, the statistical technique used as well as the methodology in general. Agency theory argues that in the modern corporation, in which share ownership is widely held, managerial actions depart from those required to maximize shareholder returns (Berle and Means 1932; Pratt and Zeckhauser, 1985).

The Agency Theory

In agency theory, a principal delegate decision making responsibility to an agent, in the case of a company the agents are the directors /managers.

The theory implies trusting resources to the agent and in turn these agents must usually produce a report regarding the use of resources both in quantitative and qualitative manner. Those entrusted with decision making authority are generally regarded as having a duty of 'accountability' a duty to demonstrate how they managed the resources entrusted to them.

Agency theory posits that agents have more information than principals and that this information asymmetry adversely affects the principals' ability to monitor whether or not their interests are being properly served by the agents (Gerrit and Mohammad, 2007). The key to agency theory is the assumption that the interest of principals and agents diverge or may be in conflict with one another. Agency theory is based on this relationship between investors (principals) and managers (agents). The simplest agency model assumes that no agent is trustworthy and if an agent can make himself better off at the expense of a principal then he will.

It is pertinent to mention that the agency theory was originated in 1973 by Mitnick. A simple agency model suggests that, as a result of information asymmetries and self interest, principals lack reasons to trust their agents and will seek to resolve these concerns by putting in place mechanisms to align the interests of agents with principals and to reduce the scope for information asymmetries and opportunistic behaviour. An audit provides an independent check on the work of agents and of the information provided by an agent, which helps to maintain confidence and trust.

METHODOLOGY

The data used in this study was collected using both the primary and secondary data. The primary data was questionnaire, while the secondary data includes company's financial statements and the 2010/2011 Fact book of the Nigerian Stock Exchange. Ten years financial statements (2000 – 2009) was reviewed to determine the amount paid to the auditors as audit fees, name of auditors and if amount paid to auditors as NAS are disclosed. The data collected was analysed using both descriptive method analysis (i.e. percentage count) and Krustal Wallis Test. Statistical Package for Social Science (SPSS) was the Computer Package used.

Population of the Study

Thirty three companies was sampled to confirm whether or not companies comply with the SEC directives on auditors' tenure as well as disclosure of audit fees and NAS payment. Two companies were chosen from each sub sector, this was felt to be adequate representative of the sub sectors,

while Auditors from Major Audit firm, Auditors from small audit firms, financial analyst as well as accountants in the academics were administered with questionnaires. Purposive random sampling technique was used as it was considered to be adequate for this purpose.

Definition and Measurement of variables

The independent variables of this study are the auditor's fees, Non – Audit Service and auditor's tenure, while the auditor's independence shall be the dependent variable.

Validity and reliability of the Research Instrument

The question of validity of a measuring instrument centers on whether the instrument measures what it intended to measure (Akindele and Ajila 2008).

In order to ensure that the questionnaire and the method of administering it were suitable the researcher carried out pilot survey on ten percent (10%) of the targeted population.

DATA ANALYSIS

Three hundred (300) structured questionnaires was distributed but two hundred and thirty-eight was analysed which is about eighty percent (80%) of the total distributed questionnaire, the remaining twenty percent (20%) represent unreturned questionnaire. The analyses were categorized into two. The first category were the questions addressing the objectives of the study and the third category deals with testing of the two major hypotheses earlier mentioned.

Data Presentation

In an attempt to achieve the objectives of this study, both descriptive and inferential statistics were used. For all questions considered from the questionnaire Kruskal Wallis test was performed to test for uniformity or otherwise in the responses of the respondents. Frequency count and percentages are used to know the distribution of the responses.

Objective One: *Examine whether auditors comply with the provisions of the Companies and Allied Matters Act 2004, and other relevant regulatory framework;*

In other to achieve this objective, questions 20, 21, 22, 23, 24, 25 and 26 were used.

In order to ensure that auditors performed their duty in the interest of the investing public, CAMA (2004) regulate the appointment, removal and services that cannot be provided by auditors to their auditing clients.

According to CAMA (2004) section 358(2a) auditors are disqualified from providing consultancy, services in respect of Secretariat, Taxation and Financial Management.

TABLE 4.1: Analysis of Respondents Response on Regulatory Framework

	RESPONSES (%)				
	SA	A	U	D	SD
Quality of audit work is adequately regulated by the audit profession	40.7	43.1	3.4	8.7	4.1
Auditors in Nigeria prefer to settle disputes out of court	24.7	41.4	2.7	31.2	-
Auditing standards issues by ICAN has greatly improved the quality of financial reporting in Nigeria	17.2	70.6	5.4	2.2	4.6
The provisions in Company and Allied Matters Act (1990) are adequate to ensure Auditors Independence in Nigeria	20.2	50.0	15.1	12.4	2.3
The SEC directory is persuasive rather than compulsory	18.4	59.3	3.4	12.1	6.8
The CAMA (1990) empowers the Registrar of Companies at the Corporate Affairs Commission to regulate compliance with its financial reporting presentation requirements	19.4	42.1	8.0	22.0	8.5

SOURCE: Administered questionnaire analysed

From the table 4.1, it can be deduced that, theoretically, quality of audit work is adequately regulated by the audit profession, and auditors in Nigeria prefer to settle disputes out of court. Auditing standards issued by ICAN has greatly improved the quality of financial reporting in Nigeria, and the provisions in Company and Allied Matters Act (1990) are adequate to ensure Auditors Independence in Nigeria, the SEC directory is persuasive rather than compulsory and the CAMA (1990) empowers the Registrar of Companies at the Corporate Affairs Commission to regulate compliance with its financial reporting presentation requirements

Objective Two: *to examine whether quoted Companies in Nigeria disclose separately non audit services payment in the financial records.*

In other to achieve this objective, questions 16, 19, 22, 24, 25 and 26 were used.

Although Companies and Allied Matters Act (2004) did not specify disclosure of fees paid to the auditors in respect of the NAS in the financial statements, but because of the fact that many audit firm now emphasis NAS more that the real audit, auditors seems to compromise in

their audit work. Such threat of Self interest if care is not taken could impair auditor's independence.

TABLE 4.2: Analysis of Respondents Response on disclose of Payment on Non-Audit Services in Nigeria.

	RESPONSES (%)				
	SA	A	U	D	SD
When auditors are allowed to provide NAS to their audit client, public companies should be required by law to disclose non-audit fees paid o their auditors	80.0	11.5	1.9	1.8	4.6
Allowing auditors to provide NAS helps them to understand the client better	74.6	19.9	0.7	4.8	-
Disclosing audit and non-audit fees strengths auditor independence	22.2	60.1	3.8	3.8	10.1
Providing NAS to an audit client may create conflict of interest on the part of Auditors	6.8	12.1	3.4	59.3	18.4
Providing NAS to an audit client may enhance the professional and Business relationship that exist between the auditor and the client	20.5	51.4	8.1	12.4	7.6
Annual report of quoted companies should contain information of Non-Audit Service performed by incumbent auditor	75.4	21.1	1.8	1.7	-
Nature of audit services provided should be disclosed by the management in the financial statements	78.0	19.5	2.5	-	-

SOURCE: Administered questionnaire analysed

From the result, it shows that when auditors are allowed to provide NAS to their audit client, public companies should be required by law to disclose non-audit fees paid to their auditors, nature of audit services provided should be disclosed by the management in the financial statements and the disclosing audit and non-audit fees strengths auditor independence

Objective Three: *to examine whether audit tenure affect the auditors' independence*

Independence, through client and user trust, is an important asset for all auditors. Independence increases the effectiveness of the audit by providing assurance that the auditor will plan and execute the audit objectively. It enhances the quality of the audit and contributes to the effectiveness of the financial statements for investment decision (Lindberg and Beck, 2004). In other to achieve the stated above objective, respondents were asked to give their perception to audit tenure and auditors independence. Questions 34, 35, 40, 47, 48, 49 and 50 were used.

TABLE 4.3: Analysis of Respondents Response to correlation between audit tenure and auditors independence

	RESPONSES (%)				
	SA	A	U	D	SD
Auditor independence is impaired by the auditor's long term relationship with client	10.8	64.6	5.4	13.6	8.6
Mandatory rotation of the audit firm promote greater independence and consequently, higher quality auditing than mandatory rotation of partners	59.4	35.3	-	5.3	-
Auditors have to be independent when performing the audit work	24.5	50.5	2.1	18.6	4.3
Major pressure against independence is fear of losing a substantial audit fee from a large client company	30.1	50.9	-	10.5	8.5
Psychologically, it is difficult to question someone with whom one has a friendly relationship	20.5	57.4	2.1	15.5	4.5
The concept of audit and the concept of independence are the twin's side of the same coin. The auditor who has loss his independence has loss his 'raison d'etre" he has become dependent and a dependent auditor is a contradiction of terms	32.1	60.4	-	4.3	3.2
Audit firms should have certain procedures and suitable measures to maintain their independence	29.8	42.1	6.5	9.5	12.1

SOURCE: Administered questionnaire analysed

Tenure could impair the independence of Auditors that is after a long period, the auditor might lose his professional skepticism. Mandatory rotation of the audit firm promotes greater independence and consequently, higher quality auditing than mandatory rotation of partners. Audit firms should have certain procedures and suitable measures to maintain their independence. Conclusively, from the result of analysis, it shows that there is a greater correlation between auditor's independence and audit tenure.

Figure 1: Auditor's Independence

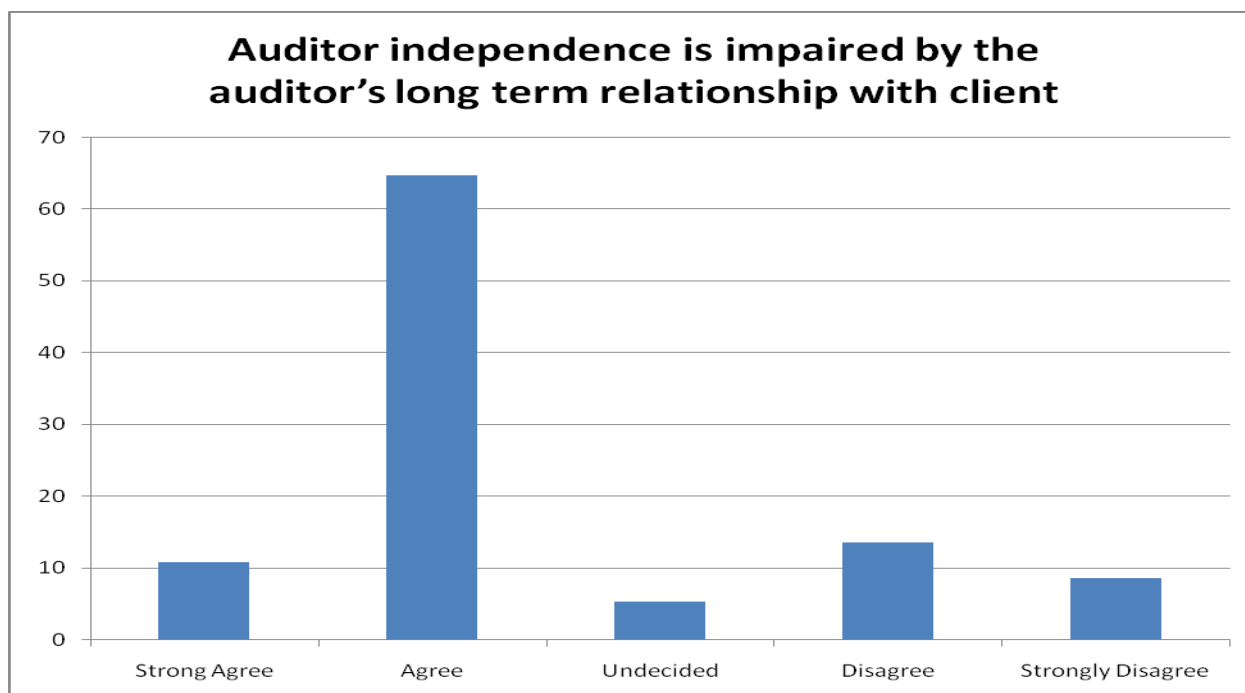

SOURCE: Author's computation.

Objective four: *to examine shareholders' role in ensuring auditors independence*

TABLE 4.4 : Analysis of Respondents Response to correlation between audit tenure and auditors independence

	RESPONSES (%)				
	SA	A	U	D	SD
Shareholders rather than the Directors should have determine appointment, Remuneration and removal of external auditors	30.2	47.4	7.5	8.7	6.3
Long term relationships cause auditors to have undue sympathy for management in the cause of problem	51.3	46.2	2.5	-	-
According to SEC, long term relationship may cause auditors to be tempted to smooth over problem areas in order to retain the engagement.	33.3	35.9	30.8	-	-

SOURCE: Administered questionnaire analysed

From the table, it can be deduced that Shareholders rather than the Directors should have determine appointment, Remuneration and removal of external auditors, long term relationships cause auditors to have undue sympathy for management in the cause of problem and may cause auditors to be tempted to smooth over problem areas in order to retain the engagement.

HYPOTHESIS TESTING

Two major hypotheses would be tested. The hypotheses were

1. H₀₁: The Provision of non-audit services by auditors and auditor's tenure do not significantly impair auditor's independence
 H₁₁: The Provision of non-audit services by auditors and auditor's tenure do significantly impair auditor's independence

2. H₀₂: The audit regulatory framework does not have significant impact on auditors independence
 H₁₂: The audit regulatory framework has significant impact on auditors independence

DECISION RULE

If the p-value calculated is greater than p-value tabulated, we will accept null hypothesis and reject the alternative hypothesis but if otherwise we will accept the alternative hypothesis and reject the null hypothesis.

Table 4.5: Hypothesis one

	N	Mean Rank
Major Firm Auditors	57	140.44
Minor Firm Auditors	63	161.31
Financial Analyst	52	151.71
Academics	66	151.15
Total	238	
	Test Statistics	
Chi-Square	7.873	
Df	3	
Asymp. Sig	.086	

SPSS output results

From the table above, it shows that Minor Auditor has the highest mean rank while Academics have the lowest Mean Rank.

From the Chi-square table, it shows that the p value calculated (0.086) is greater than p value tabulated of (0.05). Hence, we will accept the null hypothesis and reject the alternative hypothesis.

Conclusions

From the result, it shows that the Provision of non-audit services by auditors and auditor's tenure do significantly impair auditor's independence.

Figure 2: Graph of the main rank categories

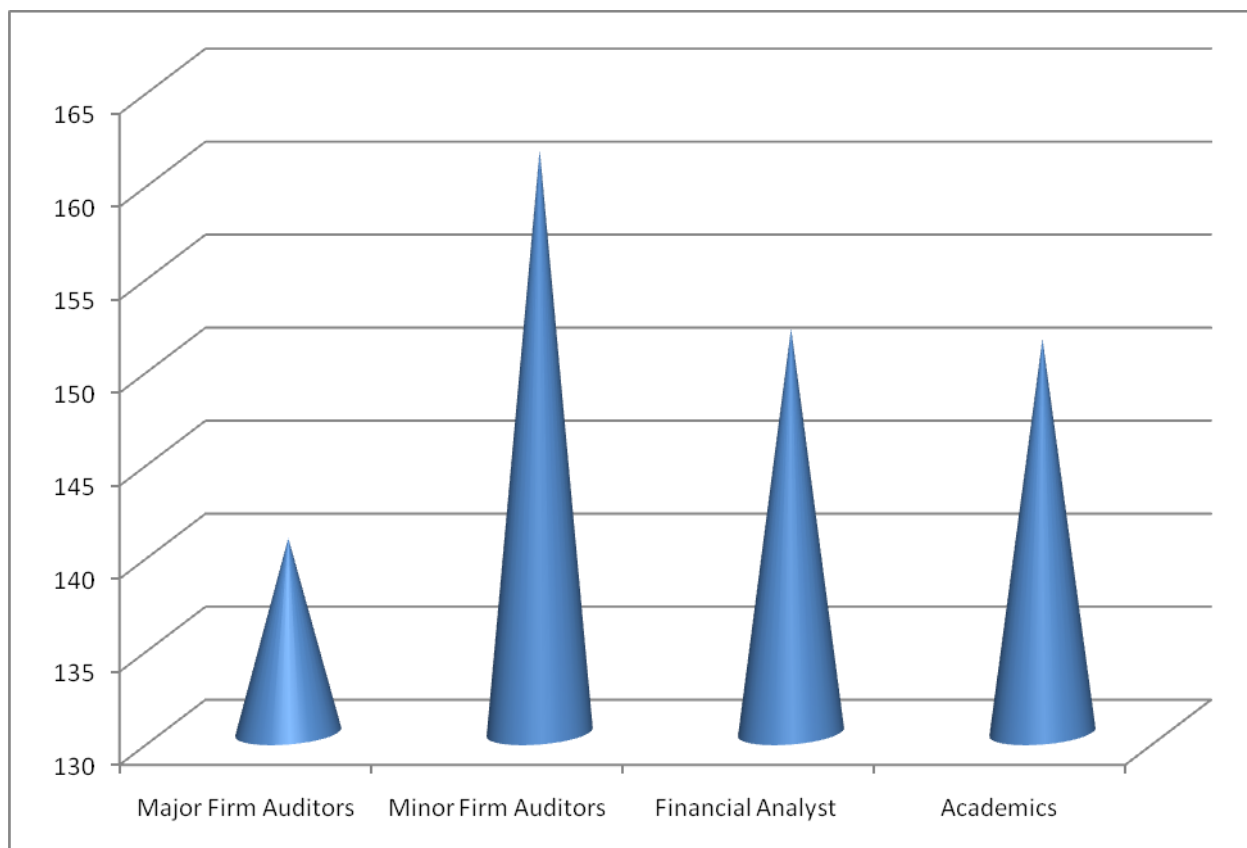

Source: Author's Computation

Table 4.6: Hypothesis two

	N	Mean Rank
Major Firm Auditors	64	114.79
Minor Firm Auditors	49	164.65
Financial Analyst	67	181.69
Academics	58	191.81
Total	238	
	Test Statistics ^a	
Chi-Square	7.873	
Df	3	
Asymp. Sig	.003	

SOURCE: SPSS output results

From the table above, it shows that Academics have the highest mean rank while major audit firms' auditors have lowest Mean Rank.

From the chi-square table, it shows that the p value calculated (0.03) is less than the p value tabulated, hence the null hypothesis is rejected and the alternative hypothesis is accepted

Conclusions

Based on the analysis carried out, from the result, it shows that the Provision of non-audit services by auditors and auditor's tenure do significantly impair auditor's independence

Figure 3: Graph of the mean graph categories

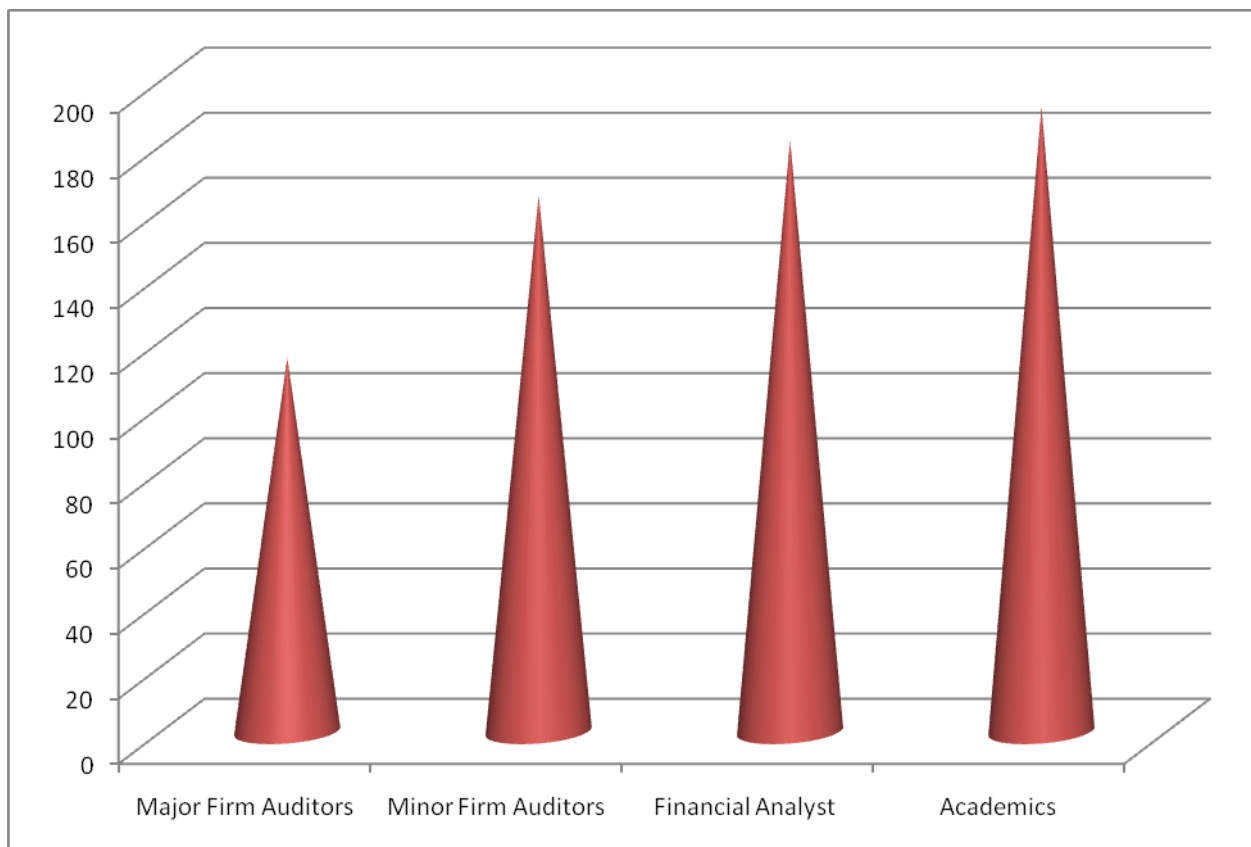

Source: Author's Computation

SUMMARY, CONCLUSION AND RECOMMENDATIONS

Attempt was made to discuss the issues that emerged from the analysis presented in the previous chapter by presenting the summary of the findings, drawing out the conclusion based on the findings while necessary recommendations are also made. The primary objective of this study is to provide evidence that joint provision of NAS and audit tenure impair the independence of external auditors and the adequacy of the regulatory framework.

Summary of Findings:

The followings are the major findings of this study:

1. Non-disclosure of NAS provided by auditors to their audit client could impair auditor independence. This was arrived at based on the response received through the questionnaire administered.
2. Tenure could impair the independence of Auditors, that is, after a long period, the auditor might lose his professional skepticism. Mandatory rotation of the audit firm promotes greater independence and consequently, higher quality auditing than mandatory rotation of partners Audit firms should have certain procedures and suitable measures to maintain their independence. Conclusively, from the

result of analysis, it shows that there is a greater correlation between auditor's independence and audit tenure.

3. From CAMA shareholders are required to determine the remuneration of auditors but directors in most cases determine appointment, Remuneration and removal of external auditors, therefore there are long term relationships exist between auditors and directors. In effect when directors does something wrong auditors may find it difficult to point it out.
4. Some regulators do not possess willingness to act when the need arises and by implication find it difficult to sanction erring auditors.
5. Many of the companies are found to continue engaging the same auditor for a long period of time. (See appendix).

Conclusion

Auditors' independence is essential to the effective working of the capital markets system. Without auditors' independence investors would be unable to rely on financial statements and, as a result, organisations would find it difficult to raise capital from the capital Market. Safeguarding auditors' independence is, therefore, a key priority not only for auditors, but also for directors, management and investor. While regulation helps to ensure the quality of services that professional accountants provide, ultimately it is the ability of the profession to put the public interest first, that will earn the profession the respect of communities and regulatory around the world.

Recommendations

Based on these findings the following are recommendations that can be useful:

- (i) The Financial Reporting Council of Nigeria need to work hand in hand with the other regulatory bodies to formulate how best to handle the issue of independence, auditor tenure, provision of NAS and expected standard of quality financial statements. The tenure of auditor engagement on audit service should not be that of SEC alone.
- (ii) Like the Sarbanes-Oxley Act, Specific NAS that cannot be performed by auditor to their audit client should be stated. Apart from that it should be monitor by independent body that must have power to penalize erring auditors and management.
- (iii) The provisions of Companies and Allied Matters Act, 2004 on auditors' independence seem to be too general. Therefore the Act need to be reviewed to enhance the auditor's independence. There

should therefore be specific pronouncement on the services that auditors can render or cannot render.

- (iv) Many companies do not see audit exercise as necessary except when they want to obtain loan from bank and for the sake of tax clearance purposes, especially private companies and as such they tend to treat audit with levity, there is the need to look into what can be done to ensure prompt audit of organizations.

REFERENCES

- Aderibigbe, P 1997, *"Auditor's Independence and Corporate Fraud"* Journal of Social Science. Vol. 10(2) pp.13, 135-139.
- Adeyemi, S.B. and Akinniyi, K.O. 2011, *"Stakeholders' Perception of the Independence of Statutory Auditors in Nigeria."* Serbian Journal of Management 6 (2) pp. 247-267.
- Akindele, S.T. and Ajila, C.O. 2008, *"Research Methods in the Social Sciences"*. Lagos: Ray Publishing Company.
- Alleyne P. A, Devonish D. and Allyene P. 2006, *"Perceptions of Auditor Independence Barbados"* Managerial Auditing Journal, Vol. 21 (6) pp. 621 – 635.
- Arrunada, B. 1997 *"Mandatory auditor rotation: A critical examination"*, International Review of Law and Economics, Volume 17, pp. 31-61.
- Berle, A. and Means G. 1932, *"The Modern Corporation and Private Property"* New York Macmillian.
- Brandon, D. M., Crabtree, A. D. and Maher, J. J. 2004, *"Non-audit fees, auditor Independence and bond ratings"*, Auditing: A Journal of Theory & Practice, vol. 23, no. 2, pp. 89-103.
- Carey, J., & Doherty, W. 1966, *"The concept of independence – review and restatement"*. Journal of Accountancy, Vol.121, No.1
- Citron, D. 2003, *"The UK's framework approach to auditor independence and the commercialization of the accounting profession"*. Accounting, Auditing and Accountability Journal 16 (2): 244–72.
- DeAngelo, H. L.E 1981, *"Auditor Size Audit Quality"* Journal of Accounting and Economics 3(3) pp183 - 199.

- Dopuch, N., and Sunder, S 1980, "*FASB'S Statement of Objectives and element of Financial accounting: A Review*". *The Accounting Review*, 55 (1).
- Dyxhoorn, H. J and Sinning, K. E 1982, "*Perception of auditor independence: its perceived effect on loan and Financial Statements Users.*" *Accounting Organizations and Society*, Vol. 7(4), pp. 337 – 347
- Ebimobowei, A. 2011, "*Non-Audit Services and the Impairment of Auditors' Independence: A Further Examination.*" *Pakistan Journal of Social Sciences* 8 (2): pp. 100-107.
- Flint, D. 1988, *Philosophy and Principles of Auditing: An Introduction*, London: Macmillan Education Ltd.
- Frankel, R.M., Johnson, M.F. and Nelson, K.K. 2002, "*The relation between auditors' fees for non-audit services and earnings management*", *The Accounting Review*, vol. 77, supplement, pp. 71-105.
- Geiger, M.A. and Raghunandan, K. 2002, "*Auditor tenure and audit reporting failures*". *Auditing*, Sarasota, Volume 21 No 1, pp. 67-78.
- Gerrit S. and Mohammed J. A 2007, "*Agency Theory as a predictor of the size of the Internal Audit Function in Belgian Companies*" Paper presented on the Annual Congress of the European Accounting Association in Lisbon April.
- Gill, G. S., Cosserat, G., Leung P and Coram P. 2001, "*Modern Auditing and Assurance Services* 6th ed, Queensland: Wiley.
- Goldman, A. and Barlev, B. 1974, "*The auditor-firm conflict of interests: its implications for independence*", *The Accounting Review*, October, pp. 707-718.
- Hilzenrath D. 2001, "*After Eron, New Doubts about Auditors*", *Washington Post* 5, December
- ICAEW (2005). "*Audit Quality - Agency theory and the role of audit*" Institute of Chartered Accountants in England and Wales.
- ICAEW (2007). "*Fundamental - Auditor Reporting*" Institute of Chartered Accountants in England and Wales.
- IFAC. (2007). *Handbook of International Auditing, Assurance and Ethics Pronouncements, The Auditor's Responsibilities to Consider Fraud in an Audit of Financial Statements*, New York: American Institute of Certified Public Accountants.

- Independence Standards Board 1997, *Serving the Public Interest; A New Conceptual Framework for Auditor Independence* New York: American Institute of Certified Public
- Jenkins, J. G.; Krawczyk, K. 2001, 'The relationship between non-audit services and perceived auditor independence', SSRN Working Paper, [WWW]<URL: <http://www.ssrn.com/>>
- Jensen, M. C., and Meckling, W. H. 1976, 'Theory of the firm: Managerial behaviour, agency costs and ownership structure', *Journal of Financial Economics*, vol. 3, pp. 305-360.
- John L. Carey 1970, "The Rise of the Accounting Profession" an accounting seminar at the University of Illinois on April 15,
- Johnstone, K.M., Sutton, M.H. and Warfield, T.D. 2001, 'Antecedents and Consequences of Independence Risk: Framework for Analysis', *Accounting Horizons*, 15(1), March, pp.1-18.
- Kleinman, G. and Palmon, D. 2001, 'Understanding Auditor Client Relationship a Multifaceted Analysis' Princeton: Markus Wiener Publishers.
- Lennox, C.S. (1999). 'Non-audit fees, disclosure and audit quality', *European Accounting Review*, Vol. 8, no. 2, pp. 239-252.
- Lowe, D.J. and Pany, K. 1995, 'CPA performance of consulting engagements with audit clients: Effects on Financial Statement Users' Perceptions and Decisions. *Auditing* A Journal of Practice & Theory, vol. 14, no. 2, pp. 35-53.
- Moizer, P. 1997, 'Independence', in Sherer, M. and Turley, S. (eds), *Current Issues in Auditing*, 3rd edition, London: Paul Chapman Publishing.
- Myers J.N. Myers L. A. and Omer J.C. 2003, "Exploring the Term of the Auditor-Client Relationship and the Quality of Earnings: A Case for Mandatory Auditor Rotation?" *The Accounting Review* Vol. 78, No, 3 pp. 779-799
- Ng, A.Y. 2002, "Public Accountability and Performance Auditing in Government," *International Journal of Auditing*, Vol. 6(2), pp. 109 – 118.
- Oladipupo, A. O. and Izedonmi 2011, Propensity of Unqualified Audit Reports and Auditors' Independence in Nigeria. *Tran campus Journal of Research in National Development*. Vol. 9. No 1. Pp 440 – 445.

- Olagunju, A. 2011, *"An Empirical Analysis of the Impact of Auditors Independence on the Credibility of Financial Statement in Nigeria."* Research Journal of Finance and Accounting. Vol 2, No 3.
- Orojo, J.O, 1992, *"Company law and practice in Nigeria"* Mbeyi & Associates; 3rd edition (1992)
- Pany, K. and Reckers, P. M. J. 1984, *'Non-audit services and auditor independence – a continuing problem'*, *Auditing: A Journal of Practice & Theory*, vol. 3, no. 2, pp.89-97
- Pratt J.W. and P.J. Zeckhauser 1985, *'Principal and Agent the Structure of Business'* Boston Harvard Business School Press.
- Pulliam,S and Blumenstein R, 2003, *"WorldCom Audit Fraud May Rise to \$11 Billion"* Wall Street Journal 1, April.
- Raghunandan, K. 2003, *'Non-audit services and shareholder ratification of auditors appointments'*, *Auditing: A Journal of Practice & Theory*, vol. 22, no. 1, pp. 155-163.
- Rohami Shafie, Wan Nordin Wan Hussin, Mohd 'Atef Md. Yusof, Md Hairi Md Sulton M.H. 2002, *"Financial Reporting at Cross Roads"*, *Accounting Horizons* Vol.16 No 4 pp.319 -328.
- Swanger, S.L. and Chewning, E.G. 2001, *'The effect of Internal Audit Outsourcing on Financial Analysts' Perceptions of External Auditor Independence'*, *Auditing: A Journal of Practice and Theory*, vol. 20, no. 2, pp. 115-129.
- Wallman, S. M. H. 1996, *'The Future of Accounting, part III: Reliability and Auditor Independence'*, *Accounting Horizons*, vol. 10, no. 4, pp. 76-97.
- Watts, R. L. and Zimmerman, J. L. 1983, *"Agency problems, Auditing and the Theory of the Firm: Some Evidence"*. *Journal of Law & Economics*, October, pp. 613-633.
- Wines, G. 1994, *"Auditor Independence, Audit Qualifications and the Provision Of Non-Audit Services"*. *Accounting and Finance*. Vol. 34. No. 1: pp. 75-86.
- Woolf E. *"Auditing Today"* New York [etc.] Prentice Hall; Hemel Hempstead: Prentice Hall Europe, 1997. Pg.5.

BANKING AND INSURANCE

FIRM'S ATTRIBUTES AND THE FINANCIAL PERFORMANCE OF NIGERIAN DEPOSITS MONEY BANKS

Abuh Adah

Department of Accountancy
College of Business and Management Studies
Kaduna Polytechnic, Kaduna

Samaila Thompson

Department of Accounting
Faculty of Administration
Ahmadu Bello University, Zaria.
[Email: samailathompson@yahoo.com](mailto:samailathompson@yahoo.com)
07030166799

Abstract

In the modern business environment, satisfactory financial performance is necessary for a firm to survive and also to meet the expectations of the stakeholders. Following the incessant crisis in the Nigerian banking sector, it is believed that certain attributes can influence such adverse condition which if not identified and addressed can further lead to more serious and negative financial performance. This study examines the impact of firm's selected attributes on the financial performance of listed deposit money banks in Nigeria. The study employed correlational research design in a sample of seven banks for a period of seven years to 2013). Ordinary Least Squares regression technique of data analysis was used in analyzing the data. The study finds out that firm's attributes have significant impact on the financial performance at 99% confidence level. The study also finds out that bank's growth and risk assets quality have significant positive effect on the financial performance of these banks in the period under review. Again, the study discovers that bank's size has no significant impact on the financial performance. The study recommends that listed deposit money banks in Nigeria should increase their efforts towards revenue generation and high quality risk assets as they are found to be positively and significantly related to their financial performance. The study also recommends that the banks' management should ensure full assets' utilization in order to improve their financial performance.

Keywords: Deposits money banks, financial performance, firm attributes, Nigerian

Introduction

In every business environment, business organizations struggle to achieve high record of growth in order to meet expectations of the stakeholders, attract the attention of prospective shareholders and the general public. Generally speaking, the investment decisions taken by investors in a particular business organization are mainly influenced by the ability of the business to remain stable and to generate sufficient profits (Chung, Firth & Kim, 2005). This strategy can influence a business organization to raise adequate funds as it is likely to positively affect the overall economic performance of the business. Generally, some business organizations will be operating successfully while others will not, instead they will be facing performance crisis. This scenario, we believed can be influenced by some variables referred to as firm attributes, which if properly identified and addressed may lead to success in performance.

This belief is supported by the views and studies of Shehu and (2011), Naser, Al-Khatib and Karbhari (2002) that, attributes such as growth, age, size, risk assets quality, human resource and so on are meant to improve firm's financial performance. However, some firms with these attributes are still dwindling and battling to survive while some are collapsing. It may be possible that the right attributes are not identified. Studies (Levine 2004 and Chakravarthy, 1986) have been conducted on the implications of firms' attributes on the performance of banking industry. However, these studies are inconclusive and they have not provided enough evidence on the nature of relationship between firm's attributes and financial performance. Following the persistent banking crisis in Nigeria, several similar factors are said to have been responsible for the performance.

This research will focus on these factors and relationships with particular reference to the Nigerian listed deposit money banks. This focus is due to the incessant crisis and fundamental role as financial intermediary of channeling funds from surplus units to deficits units of the economy for productive activities. The main objective of this study is to assess the impact of firm's selected attributes on the financial performance of listed Nigerian deposit money banks. The specific objectives are:

- i. To examine the effect of banks' growth on return on assets of listed deposit money banks in Nigeria.
- ii. To investigate the effect of banks' size on return on assets of deposit money banks in Nigeria.
- iii. To determine the impact of banks' risk asset quality on return on asset of deposit money banks in Nigeria.

In line with these specific objectives, the following hypotheses are formulated in null form:

H₀₁: Banks' growth has no significant impact on Return on asset of listed deposit money banks in Nigeria.

H₀₂: Banks' size has no significant impact on Return on asset of listed deposit money banks in Nigeria.

H₀₃: Banks' risk asset quality has no significant impact on return on assets of listed deposit money banks in Nigeria.

The time frame of the study is 2007-2013. The seven years are considered because they falls within the period in which the banking sector reforms took place in Nigeria. The independent variable of attributes is proxied by growth, size and risk assets quality which the researchers believe can have significant impact on the financial performance in Nigerian banking sector. The outcome of the study is expected to be beneficial to the shareholders who have to make optimal decisions as regard the financial performance of the banks. It will also be of benefit to the regulatory authorities for policy decision and researchers in the field of banking and finance.

The paper is structured into five sections: section one discusses the basic introduction to the work, section two presents the relevant literature and theoretical framework; section three gives the description of the data, measurement of variables and presents the discussion on specification or model. Section four discusses the results from the model used and section five presents the conclusion which includes recommendations.

Literature Review

Zeitun and Tian (2007) explain that the concept of performance is a controversial issue in the financial strategy of most corporate organizations due to its multi-dimensional meanings. Performance measures are either financial or operational. Financial performance such as profit maximization, maximizing profit on assets and maximizing shareholders benefits are core of firm's effectiveness (Chakravarthy, 1986). Operational performance measures such as growth in sales and growth in market share provide a broad definition of performance as they focus on the factors that ultimately lead to financial performance (Hoffer & Sandberg, 1987, as cited in Zeitun, 2007).

Financial performance to shareholders and other stakeholders is a benchmark for both investment and financial decisions. The performance of the economy at the national and regional levels directly affects the business strategy of individual's financial institutions and may affect the overall performance of industries. For instance, the economic down turn could adversely have negative or positive impact on the financial services industry and this may result to a slower asset growth, increased loan losses and diminished profitability (Yunusa, 1998). Another way of

measuring corporate performance according to Heng & San (2011) is productivity, profitability, growth or even customer satisfaction. They contend that these tools are closely related. Barbosa and Louri, (2005), opine that financial measurement is one of the tools which indicate the financial strengths, weakness, opportunities and threats.

The Nigerian quoted banks are financial intermediaries that accept deposits and channel them into lending activities, either directly by loaning or indirectly through capital markets. A bank links customers that have capital deficits and customers with capital surplus together. Banks are themselves corporations. Corporate governance of banks affects banks' valuation, their cost of capital, their performance and their risk taking behaviour. Formal econometric studies by (Levine 1997, 2004) show that banks exert a strong impact on economic development. When banks efficiently mobilize and allocate funds, this lowers the cost of capital of firms, boosts capital formation and stimulates productive growth (Levine 2004).

Okeahalan (2004) states that, banks are basically financial institutions whose performance and productivity utilization of resources should be determined on the basis of their financial statements. The idea is that, if banks are performing profitably and their investment are doing well in terms of income generation, and then the profitability of the banks also depends on the efficiency of the banks themselves. Howard and Hayness (2001) explain the important role of the financial sector (banks) such as intermediation, controls and complying with regulations of the authorities. These controls and regulations lead developing countries' financial markets to be characterized by financial repression. Apart from this, the direct intervention in the banking sector's operations leads in some cases of highly concentrated market structure in the banking industry which in turn have implications on saving mobilization, intermediation and bank performance.

Returns on assets (ROA) is a good internal management ratio because it measures profit against all the assets an organization uses to make those earnings. Hence, it is a way to evaluate the organization's profitability, performance and effectiveness. It is also more appropriate here because divisional managers seldom get involved in raising money or in deciding the mix between debt and equity (Kristy & Susan, 1984). ROA provides good information about a firm's financial performance in terms of using assets to create income. It shows the percentage of profit that a corporation earns in relation to its overall resources. Thus, it is considered as a measure of efficiency. A firm with high ROA means that it is good at translating assets into profit. It is also called a profitability or productivity ratio (Carcello & Neal (2000)). ROA is generally seen as a stable financial performance ratio. For this reason, an increasing ROA indicates that a

firm generates more profitability while a decreasing ROA indicates that a firm generates less profitability.

There are several underlying firm characteristics that differ systematically across firms. Previous research has shown that firms engaging in earnings management activity are often small in size (Keating & Zimmerman (1999), less profitable (Defond & Jiambalvo, 1991), lower growth rate, and have higher leverage than their industry average (Carlin & Mayer, 2000). On the other hand, Ali and Hwang (2000) and Archambeault and Dezoort (2001) investigate the extent of mandatory disclosure by 94 listed firms both on the Dhaka Stock Exchange (DSE) and the Chittagong Stock Exchange (CSE) respectively. Both of them examine the relationship between company specific characteristics: age, size, status, profitability and mandatory disclosure of the sampled firms, the latter included auditors' type and liquidity as his explanatory variables. The two studies found that all the attributes are positively significant to the information quality.

Adelopo (2010) finds a significant positive relationship between voluntary disclosure and firm size, measured as the natural logarithm of total asset. Empirically, evidences have shown positive and significant association between firm size and financial reporting quality (Singhvi & Desai (1971); Buzby. 1975; Firth, 1979; Chow & Wong-Boren, 1987; Wallace & Naser, 1995; Cooke, 1989; Wallace et al, 1994; Raffournier, 1995, Inchausti, 1997, Owusu-Ansah, 1998 and Francis, Lafond, Olsson & Schipper 2004). On the other hand, Song and Windram (2004) and Malone, Fries, and Jones (1993) found contrary result.

Sanda, Mikailu and Garba (2005) in their studies which examine the relationship between director shareholding, board size and firm financial performance, conclude that there is no significant relationship between director-ownership and firm performance and there is also a negative relationship between board size and firm's financial performance in Nigeria. Research in finance shows that firm's characteristics such as growth, company size and efficiency can predict the future stock price. Jonas and Blanchet (2000) analyze 478 firms in USA during 1982- 1998 and conclude that, big sized and profitable firms with high level advertising expenditure have better performance in terms of those three measurements.

The theoretical framework of this study is the agency theory because it is mostly used by researchers to understand the relationship between firm's attributes and financial performance (Carter & Simpson, 2003). The agency theory suggests that the firm can be viewed as a nexus of contracts (loosely defined) between resource holders. It involves a contract under which the principal (owners) engages another party (managers) called agent to perform some services on their behalf, where some power of decision making are delegated to the agent (Jensen and

Meckling, 1976). The agent may not always act in the best interest of the principal.

Research Methodology

The correlation research design was adopted for this study; the design is selected because it is to test the relationship and impact of one variable on another. This is consistent with the objective of this study, that is, assess the impact of firm attributes on the financial performance of listed deposit money banks in Nigeria. Data were generated from the secondary sources (financial statements of tile sampled banks) for all the period of seven (7) years (2007-2013).

The population of the study is all the seventeen (17) banks listed on the floor of the Nigerian Stock Exchange Market as at 31st December, 2013. Two banks that were not listed' for all the period were dropped and 15 banks emerged as a new population. The study employed systematic sampling techniques and seven (7) banks were arrived at as the sample of the study. The sampling technique used was that, the banks were arranged alphabetically and the even numbers were chosen. The study also employed Ordinary Least Square (OLS) regression as tool for data analysis. The technique was chosen because of its effectiveness in investigating and estimation of the impact of one variable on another. The analysis was conducted using STATA 10.1.

Variables Measurement and Model Specification

The dependent variable of the study is financial performance, proxy by return on assets, while the independent variable is firm attributes (bank size, bank growth and risk asset quality). The variables mcasurel11cntsarc presented in table 1

Table 1 Variables Measurement

Variables	Measurement
Return on Assets (ROA)	Is measured as a ratio of profit after tax to total assets
Bank Growth (GROWTH)	Is measured as a difference between current year gross earnings (total revenue) and previous year gross earnings.
Bank Size(SIZE)	Is measured as a natural log of total assets
Bank Risk Assets Quality	Is measured as a ratio of total non-performing loans and advances to total loans and advances

The model of the study is mathematically presented as follows:

$$ROA_{it} = \alpha_0 + \beta_1 GROWTH_{it} + \beta_2 SIZE_{it} + \beta_3 RAQLTY_{it} + \epsilon_{it} \dots \dots \dots i$$

Where:

ROA_{it} = return on asset of bank i in year t

$GROWTH_{it}$ = growth of bank i in year t

$SIZE_{it}$ = size of bank i in year t

$RAQLTY_{it}$ = risk asset quality of bank i in year t

α_0 = intercept, β_1 - β_3 = coefficient, ϵ_{it} = residual.

Results and Discussion of Findings

In this section, the results obtained from the data collected for the study are presented and discussed. The section begins with the descriptive statistics as presented in Table 2 below.

Table 2: Summary of Descriptive Statistics

Variable	Mean	SD	Min	Max	N
ROA	0.0099	0.0835	-0.4479	0.1615	49
GROWTH	0.0469	0.2909	-0.7834	0.9461	49
SIZE	20.1632	0.7712	18.5249	21.6249	49
RAQLTY	0.1306	0.1351	0.0139	0.6637	49

Source: STATA OUTPUT

The results from table 2 above show that the measure of financial performance of the sampled listed deposit money banks return on assets (ROA) has an average value of 0.0099 with standard deviation of 0.0835, and minimum value of -0.4479 and 0.1615 as the maximum value. The standard deviation of 0.0835 implies that the data deviate from both side of the mean value by 0.0835, further implying that the data is widely dispersed from the mean because the standard deviation is higher than the mean. Moreover, the results indicate that the average financial performance of the sampled banks is 0.99% return on assets. The table also shows that the firm attribute variable, firm growth (GRWTH) has an average value of 0.0469 with standard deviation of 0.2909 with minimum and maximum values of -0.7834 and 0.9461 respectively. This shows that the average rate of growth of the sampled banks is 4.69% of the total assets, and the deviation from the mean is 29.09%.

Table 2 above also shows that the average size (SIZE) of the sampled banks, which is the natural log of total assets, is 20.1632 with standard deviation of 0.7712, and minimum and maximum values of 18.5249 and 21.6249 respectively. The table also indicates that the last measure of financial performance in this study, risk assets quality (RAQLTY) has an average value of 0.1306 with standard deviation 0.1351, the minimum

and maximum values are 0.0139 and 0.6637 respectively. This implies less risk assets quality in the sample banks, because the mean which is the ratio of non-performing loans and advances to total loans and advances is 13.06% which is far from the recent 4% standard.

Correlation Results

In this section, the correlation Coefficients of the variables of the study are presented in Table 3 as follows:

Table 3: Coefficient of Correlation

Variables	ROA	GROWTH	SIZE	RAQLTY
ROA	1	1		
GRWTH	0.3146 (0.0277)			
SIZE	0.0928 (0.5261)	0.0163 (0.9116)	1	
RAQLTY	0.4387 (0.0016)	-0.1118 (0.4444)	0.2043 (0.1592)	1

Source: STATA OUTPUT (Note, P-Values in Parentheses)

Table 3 above presents the Pearson correlation coefficient of the firm attributes (firm size, firm growth and bank risk assets quality) and the financial performance (return on assets) of listed deposit money banks in Nigeria. The table shows a significant positive relationship between financial performance (ROA) and firm's growth (GRWTH) from the correlation coefficient of 0.3146 which is significant at 5% level of significance (from the p-value of 0.0277).

This relationship suggests that financial performance increases as bank's growth. Similarly, the results from the table indicate that, there is a positive association between financial performance (ROA) and the size of the banks (SIZE) from the correlation coefficient of 0.0928 which is not statistically significant at all levels of significance (from the p-value of 0.5261). This also implies that, the larger the size of a bank, the higher the financial performance, though not statistically significant at all levels. Moreover, the results from the table show a significant positive relationship between financial performance (ROA) and bank risk assets quality (RAQLTY), from the correlation coefficient of 0.4387 which is statistically significant at 1% level of significance (p-value of 0.0016), suggesting that the higher the lending, the higher the interest income recognizes and the higher the financial performance. Thus, it did not consider whether the loans are performing or not.

Regression Results

This section presents and analyzes the regression results of the models of the study. The results are presented in table 4 below.

Table 4: Summary of OLS Regression Results

Variables	Statistics	P-Values
R ²	0.3265	
Adj. R ²	0.2816	
F-Statistic	7.27	0.0004
Mean VIF	1.04	
Hetest: Chi2	0.09	0.7642

Source: STATA OUTPUT

The results from table 4 above indicate that, the independent variables of firm's attributes (bank growth, bank size and bank risk assets quality) explained around 28.16% of the variations in the financial performance (ROA) of the sample listed deposit money banks in Nigeria, from the coefficient of multiple determinations (adjusted R² of 0.2816). The table also shows that the model is fitted as evident by the F-Statistic of 7.27 which is significant at 1% level of significance (as indicated by the P-value of 0.0004).

Moreover, table 4 shows an absence of Heteroskedasticity in the results as indicated by the Breuch Pagan/Cook-Weiberg test for heteroskedasticity Chi2 of 0.09 with p-value of 0.7642. However, the null hypothesis that there is constant variance in the residuals is not rejected; as the value is not statistically significant at all levels of significance. Therefore, there is constant variance (homoscedasticity). The table on the other hand, indicated the absence of the perfect multicollinearity among the explanatory variables, as shown by the mean variance inflation factor (VIF) of 1.04. The decision criterion for the Variance Inflation Factor is that a value of 10 and above implies the presence of perfect multicollinearity.

Hypotheses Testing

The hypotheses formulated for the study are tested in this section. Table 5 presents the coefficients of the variables of the study from which the hypotheses are tested.

Table 5: OLS Coefficients of the Model

Variables	Coefficients	P-Values
-----------	--------------	----------

GRWTH	0.1059	0.004
SIZE	-0.0029	0.926
RAQLTY	0.2029	0.000
CONSTANT	0.0079	0.977

Source: STATA OUTPUT

The results from table 5 above show that, bank growth (GRWTH) has a significantly positive statistical impact on the financial performance (ROA) of the listed sampled deposit money banks in Nigeria, from the coefficient of 0.1059 which is significant at 1% level of significance (p-value of 0.004). This suggests that, as a bank grows by N1, financial performance increases by 10.59K; this result is significant at 99% confidence level. Based on this, the study rejects the null hypothesis one. The outcome of this work is an agreement with the empirical studies of Chow & Wong-Boren (1987), Wallace & Naser (1995) and Inchausti (1997) highlighted in the review of literature section above.

(H₀₁) which states that, banks' growth has no significant effect on the financial performance (ROA) of listed deposit money banks in Nigeria. The study therefore infers that banks' growth is significant in improving the financial performance of listed deposit money banks in Nigeria during the period under review.

The table also shows that, banks' size (SIZE) has negative impact on the financial performance (ROA) from the coefficient of -0.0029 that is not statistically significant at all levels of significance (p-value of 0.926). This suggests that the size of the bank has no significant influence on the financial performance. Based on this, the study does not reject the null hypothesis two (H₀₂) which states that, banks' size has no significant effect on the financial performance (ROA). The study therefore infers that bank size is not significant in improving the financial performance of listed deposit money banks in Nigeria during the period under review. This result is contrary to the empirical study of Raffournier (1995) and Francis, Lafond, Olsson & Schipper (2004) but it is similar with the studies of Song and Windram (2004) and Malone, Fries & Jones (1993) revealed above.

From the table, banks' risk assets quality (RAQLTY) has significant positive effect on the financial performance (ROA) of listed deposit money banks in Nigeria, from the coefficient of 0.2029 which is statistically significant at 1% level of significance (p-value of 0.000). This suggests that, the bank risk assets quality has significant positive influence on the financial performance at 1% significance level. Based on this, the study rejects the null hypothesis three (H₀₃) which states that, banks' risk assets quality has no significant effect on the financial performance (ROA) of listed deposit money banks in Nigeria. The study therefore infers that

banks' risk assets quality is significant in improving the financial performance of listed deposit money banks in Nigeria during the period under review. This result is not different from the studies conducted by Singhvi & Desai (1971), Owusu-Ansah (1998) and Francis, Lafond, Olsson & Schipper (2004).

The implication of these findings is that, if deposit money banks in Nigeria fail to improve their growth by generating sufficient revenue and the quality of their risk assets, their financial performance will deteriorate even to the extent of discontinuity of the business. The findings also imply that the sampled banks possibly have redundant and possibly idle assets that are not fully utilized to improve their financial performance.

Conclusion

Based on the data analysis in the preceding section and the analysis of the research hypotheses, the study concludes that, firms' attributes have significant impact on the financial performance of listed deposit money banks in Nigeria. The study also concludes that banks' growth and risk assets quality have significant positive effect on the financial performance of listed deposit money banks in Nigeria during the period of the study. Similarly, the study concludes that bank's size has no significant impact on the financial performance of listed deposit money banks in Nigeria.

From the findings and conclusions of this study, the study recommends that listed deposit money banks in Nigeria should increase their efforts towards revenue generation and improved quality of risk assets. These areas are found to be positively and significantly related to financial performance. The study also recommends that the banks' management should ensure full assets utilization in order to improve their financial performance.

References

Adelopo, I. A. (2010); Voluntary Disclosure Practice among listed companies in Nigeria available at SSRN. <http://ssrn.com/abstract>.

Ali, A., & Hwang, L. (2000); Country – specific factors related to financial reporting and value relevance of accounting data. *Journal of Accounting Research*, 38 (1), 1- 12.

Alsaeed, K. (2006); The Association between firm Specific Characteristics and Disclosure: The case of Saudi Arabia, *Managerial Auditing Journal* Vol. 21 No.5, 476-496.

Archambeault, D. & Dezoort, F. T. (2001); Auditor opinion shopping and the audit committee: An analysis of suspicious auditor switches. *International Journal of Auditing*, 5, 33 – 52.

Barbosa, N. & Louri, H. (2005); Corporate performance: Does ownership matters? A comparison of foreign- and Domestic - owned firms in Greece and Portugal. *Review of Financial Organization*, 27 (1) 73-102.

Buzby, S. L. (1975); Company size, listed versus unlisted stocks, and the extent of financial disclosure. *Journal of Accounting Research*. 13 (1), 16 – 37.

Carcello, J. & Neal, T. (2000); Audit committee composition and auditor reporting. *Accounting Review*, 75, 453 – 467

Carlin, W. & Mayer, C. (2000); *Finance, investment and growth*. Unpublished Paper, University College London and University of Oxford said business School. Retrieved from [www/ttrw](http://www.ttrw)

Carter, D. A, Simkins, S. J & Simpson, W. G. (2003); Corporate Governance, Board Diversity & firm Value, *Financial Review*. Vol. 38, No. 1. pp. 33-53.

Chen, M. & Hambrick, D. C. (1995); Speed stealth & selective Attack: How small firms differ from large firms in competitive behavior. *Academy of Management Journal* 38(2), 453-482.

Chakravarthy, B. S. (1986); Measuring strategic performance. *Strategic Management Journal* 7, 437-58.

Chow, C. & Wong–Boren, A. (1987); Voluntary financial disclosure by Mexican corporations. *The Journal of Accounting Review*, July, 533 – 541.

Chung, R., Firth, M. & Kim, J. B. (2005); Earnings management, surplus free cash flow and external monitoring. *Journal of Accounting Horizons*, 14 (3), 353 – 363.

Defond, M. L. & Jiambalvo, J. (1991); Incidence and circumstances of accounting errors. *The Accounting Review*, 66, 643 – 655.

Firth, M. (1979); The impact of size, stock market listing and auditors on voluntary disclosure in corporate annual reports. *Journal of Accounting and Business Research*, 9 (36), 273 – 280.

Francis, J., Lafond, R., Olsson, P. & Schipper, K. (2004); Cost of equity and earnings attributes. *Journal of Accounting Review*, 79 (4), 967 – 1010.

Heng, B.T & San, O. T. (2011); Capital structure and corporate performance of Malaysia construction sector. *International Journal of Humanities and Social Science*, 1, 29-35.

Howard, M & Hayness, C. (2001); Commercial bank efficiency in Barbados. *Savings and Development*, Vol. 25.

Inchausti, B. G. (1997); The influence of company characteristics and accounting regulation on information disclosed by Spanish firms. *Journal of European Accounting Review*, 6 (1), 45 – 48.

Jensen, M.C & Meckling, W. H. (1976); Theory of firm: managerial behavior, agency costs and ownership structure, *Journal of Financial Economics*, Vol. 3, pp. 305-306.

Jonas, G., & Blanchet, J. (2000); Assessing quality of financial reporting. *Journal of Accounting Horizons*, 14(3), 353-363.

Keating, A. & Zimmerman, J. (1999); Depreciation policy changes: Tax, earnings- management and investment opportunity incentives. *Journal of Accounting and Economics*, 28, 359 – 389.

Kristy, J. E. & Susan, Z. D. (1984); Finance without fear. New York, *American Management Association*. 49 (4). 53-61

Levine. R. (1997); Financial development and Economic growth: views and agenda, *Journal of Economic Literature* 35, 688-726.

Levine, R. (2004); The corporate governance of banks: A concise discussion of concepts and issues in global corporate governance forum Washington, D.C and the Certified Accountant, 18 April.

Malone, D. Fries, C. & Jones, T. (1993); An empirical investigation of the extent of corporate financial disclosure in the oil and gas industry. *Journal of Accounting, Auditing and Finance*, 8(3), 249 – 273.

Macesich, G. (2000); Central Banking: The Early Years: Issues in Money and Banking.

- Mintzberg, H. (1979); *The structuring of organizations: A synthesis of the research*. Prince - Hall.
- Okeahalam, C. (2004); An Evaluation of the financial performance of the African Development Bank, *International Journal Accounting, Auditing and Performance Evaluation*. I: 125-130
- Owusu-Ansah, S. (1998); The impact of corporate attributes on the extent of mandatory disclosure and reporting by listed companies in Zimbabwe. *The International Journal of Accounting*, 33(5), 605 – 631.
- Naser, K., Al-Khatib, K. & Karbhari, R. (2002); Empirical evidence on the depth of corporate information disclosure in developing countries: The case of Jordan. *International Journal of Commerce and Management*, 12 (3 & 4), 122- 155.
- Sanda, A. U. Mikailu, A. S. & Garba, T. (2005); Corporate governance mechanisms and firm financial performance in Nigeria. AERC Research Paper, 149.
- Shehu, U. H. (2011); Corporate governance and financial reporting quality: A study of Nigerian deposit money, *International Journal of Research in Computer Application and Management*, 1 (6).
- Singhvi, S. S. & Desai, H. B. (1971); An empirical analysis of the quality of corporate financial disclosure. *The Journal of Accounting Review*, 46 (1), 120 – 138.
- Song, J. & Windram, B. (2004); Benchmarking audit committee effectiveness in financial reporting. *International Journal of Auditing*, 8, 195 – 205.
- Yunusa. L. M. (1998); *The community banking system in Nigeria*. Publication, pp: 1-4.
- Zeitun, R. & Tian G. G. (2007); Capital structure and performance. Evidence from Jordan. *The Australasian Accounting: Business and finance Journal*, Vol. I. No. 4.

INFORMATION TECHNOLOGY AND HUMAN CAPITAL DEVELOPMENT: NIGERIAN BANKING INDUSTRY EXPERIENCE – Adegboyega R. A. & Akinde M. A.

Abstract

The study examine the effect of information technology on human capital development in respect of Nigerian Banks. The research study used both primary and secondary data with survey research design. In addition, descriptive statistics, correlation and analysis of variance were used to test the statistical hypothesis. The findings reveal that information technology has positive influence on human capital development. It also reflect that human capital development improves and/or deteriorates if the cost of information technology is increased or decreased respectively and that it is not only information technology that affect human capital development. The study recommend, among others, that Nigerian banks should invest continually in both technology and human resources development in order to create value for knowledge and technology driven system that meets the world standard.

Key words: *Information technology, human capital development, Nigerian banks, value creation and world standard.*

1.0 INTRODUCTION

1.1 Advent of Information Technology

God has been so kind to create human beings and endowed him with speech, wisdom and knowledge,. He communicated with human being when he has any information to pass to mankind. In fact this act is the oldest activity in the world. Information has been one of man's natural gifts from the early history of mankind. Information has been concerned with how to collect, store, retrieve, distribute and communicate the data by the fastest means possible at the lowest cost. The consequence of this is that right from the beginning of civilization, man has used various methods to record information, ranging from clay tablets in ancient Mesopotamia through papyrus, parchment and wax to sophisticated forms of paper, films and magnetic tapes. The methods for communicating the information have varied equally, from voice, smoke signals, beating of drums, the pony express, the dog or the carrier pigeon, writing, printing, distribution achieved through books, magazines, newspapers, and the postal system to present-day telecommunication systems.

Porter and Miller (1985) noted that technological progress principally affected the physical component of how and what businesses do. During the industrial revolution, companies had competitive advantage by substituting machines for human labour. Information processing at that time was mostly the result of human effort. Now the pace of technological change is reversed. Information technology (IT) is advancing faster than technologies for physical processing. The costs of information storage, manipulation and transmission are falling rapidly, and the boundaries of what is feasible in information processing are at the same time expanding.

Computer technology or as popular referred Information Technology (IT) is defined as the modern handling of information by electronic means which involves access to, storage of, processing, transportation or transfer and delivery. IT has led to a rapid increase in the application of technology to the process, production, storage and retrieval of information and communication. It has provided answers to the emerging needs of health, education, banking and all works of life.

1.2 Human Capital Development

Human capital has been in existence for a long time from the day mankind has been told to live and eat from their sweats. According Schultz (1993), the term "human capital" has been defined as a key element in improving a firm assets and employees in order to increase productive as well as sustain competitive advantage. To sustain competitiveness in the organization human capital becomes an instrument used to increase productivity. Human capitals refer to processes that relate to training, education and other professional initiatives in order to increase the levels of knowledge, skills, abilities, values, and social assets of an employee which will lead to the employee's satisfaction and performance, and eventually on a firm performance. Rastogi (2000) stated that human capital is an important input for organizations especially for employees' continuous improvement mainly on knowledge, skills, and abilities. Thus, the definition of human capital is referred to as "the knowledge, skills, competencies, and attributes embodied in individuals that facilitate the creation of personal, social and economic well-being" (Organization for Economic Co-Operation and Development or OECD, 2001: 18).

1.3. Information Technology and Human Capital Development

The effect of information technology (IT) investments on bank's activities, the human capital development and asset growth is an important issue as this type of investment constitutes a substantial component of costs and exerts a strong influence on bank operations and strategy. IT places

strong constraints on the type of products and delivery channels offered, the degree of customization possible, and the speed at which banks can respond to competitive opportunities or threats. Therefore, this study examines Information Technology and Human Capital development (a Nigerian Banking Industry experience).

2.0 LITERATURE REVIEW

2.1 Information Technology

Information Technology (IT) comprises both computer and telecommunications technology for the collection, storage, retrieval, reproduction, processing, diffusion, and transmission of information (Bosworth & Triplett, 2000 and Brynjolfsson&Hitt, 2000). It encompasses hardware, software, and the skills of IT personnel. IT-related reorganization or reengineering of communication and decision processes, as well as operations including new product or service development based on IT, are also considered as IT investments necessary for the effective use of IT. Information Technology products used by commercial banks are IT applications providing banking services to customers and those supporting the information needs of the staff responsible for banking operations (Essinger, 1993; Johnson et al., 1995; Morisi, 1996). They are divided into two categories based on their application, the retail IT products and the wholesale IT products.

Electronic payment systems are retail IT products that provide payment facilities with the customers' direct participation. Retail IT products are supported by internal systems, which are applications within the bank that assist retail staff dealing with retail customers and applications used for purely administrative purposes. Similarly, wholesale IT products relate to the front office systems that support wholesale staff directly dealing with corporate customers. The front office systems process two categories of information, basic price and market information and decision support (or value-added) information.

Decision support requires more extensive analysis to support the trader or investment manager to make effective decisions. Wholesale IT products also relate to back office systems that handle the bank's administrative tasks and support back office staff who provides processing and support services. Where a bank provides both retail and wholesale services, there is invariably an overlap between the internal systems and the back office systems for administrative support.

Also, there is an overlap between the communication systems (local area networks [LANs] and wide area networks [WANs]) used to support various retails and wholesale IT products. The communication systems

supporting retail IT products are classified as internal systems, while those supporting wholesale IT products are considered front office systems because, in addition to providing networks of workstations, they are used by the front office staff to communicate with distant corporate customers via LANs and WANs. Information Technology measures indicate the level of IT implementation in the bank. They include total IT expenses, number of IT employees, IT hardware and software capital, data processing power index, and IT expenses per employee.

Data is the coded representation of facts, ideas and instructions such that the representation can be processed, communicated and interpreted by computers and the main processor (Lucey, 1987). Information is the meaning assigned to data within some context for the use of that data (Walter, 1992). Telecommunications are the transmission of data-carrying signals, often between two widely separated points (The Cambridge Encyclopedia, 1990).

Information technology is a term that generally covers the harnessing of electronic technology for the information needs of a business at all levels. It utilizes computer-based systems as well as telecommunication technologies for the storage, processing and communication (Anderson, 1990 and Claus and Schwill, 1992). Longley and Shain (1982) also defined IT as the acquisition, processing, storage and dissemination of vocal, pictorial, textual and numerical information by a microelectronics based combination of computing and telecommunications. While an information system (IS) is a group of formal processes that together collect, retrieve, process, store and disseminate information for the purpose of facilitating, planning, control, coordination and decision making in organizations, IT on the other hand provides the technical solutions identified in the IS, including the networks, hardware and software (Grainger-Smith and Oppenheim, 1994).

In addition, Porter and Miller (1985) conceive of IT to broadly encompass the information that businesses create and use, as well as a wide spectrum of increasingly convergent and linked technologies that process the information. In addition to computers, then, data-recognition equipment, communication technologies, factory automation and other hardware services are involved. Traditionally, telephone, radio and television were referred to as media technology (Hanson and Narula, 1990).

IT today is basically electronics and is based on integrated circuits or silicon chips. Hanson and Narula (1990) further identified two major forms of IT as Telematics (meaning 'big media') and Ethnotronic (meaning 'small media'). Telematics are to be identified with such technologies as computers, telephone, satellites, television, radio, video

and those that rely on large scale infrastructure. Ethnotronics include technologies such as typewriters, audio cassette recorders, fax machines, paper copiers, calculators, digital watches and other more personal types of technology.

2.1.1 Technology and Banks Transformation

Computers are getting more sophisticated. They have given banks a potential they could only dream about and have given bank customers high expectations. The changes that new technologies have brought to banking are enormous in their impact on officers, employees, and customers of banks. Advances in technology are allowing for delivery of banking products and services more conveniently and effectively than ever before - thus creating new bases of competition. Rapid access to critical information and the ability to act quickly and effectively will distinguish the successful banks of the future.

The bank gains a vital competitive advantage by having a direct marketing and accountable customer service environment and new, streamlined business processes. Consistent management and decision support systems provide the bank that competitive edge to forge ahead in the banking market place. The advantages accruing from information technology are in three-directional - to the customer, to the bank and to the employee.

(a) Customer

Banks are aware of customer's need for new services and plan to make them available. IT has increased the level of competition and forced them to integrate the new technologies in order to satisfy their customers. They have already developed and implemented a certain number of solutions among them:

- **Self-inquiry facility:** Facility for logging into specified self-inquiry terminals at the branch to inquire and view the transactions in the account.
- **Remote banking:** Remote terminals at the customer site connected to the respective branch through a modem, enabling the customer to make inquiries regarding his accounts, on-line, without having to move from his office.
- **Anytime banking: Anywhere banking:** Installation of ATMs which offer non-stop cash withdrawal, remittances and inquiry facilities. Networking of computerized branches inter-city and intra-city, will permit customers of these branches, when interconnected, to transact from any of these branches.

- **Telebanking:** A 24-hour service through which inquiries regarding balances and transactions in the account can be made over the phone.
- **Electronic Banking:** This enables the bank to provide corporate or high value customers with a Graphical User Interface (GUI) software on a PC, to inquire about their financial transactions and accounts, cash transfers, cheque book issue and inquiry on rates without visiting the bank. Moreover, LC text and details on bills can be sent by the customer, and the bank can download the same. The technology used to provide this service is called electronic data interchange (EDI). It is used to transmit business transactions in computer-readable form between organizations and individuals in a standard format.

(b) Bank

During the last decade, banks applied IT to a wide range of back and front office tasks in addition to a great number of new products. The major advantages for the bank to implement IT are:

- Availability of a wide range of inquiry facilities, assisting the bank in business development and follow-up.
- Immediate replies to customer queries without reference to ledger-keeper as terminals are provided to Managers and Chief Managers.
- Automatic and prompt carrying out of standing instructions on due date and generation of reports.
- Generation of various MIS reports and periodical returns on due dates.
- Fast and up-to-date information transfer enabling speedier decisions, by interconnecting computerized branches and controlling offices.

(c) Employees

Information Technology has increased their productivity through the followings:

- Accurate computing of cumbersome and time-consuming jobs such as balancing and interest calculations on due dates.
- Automatic printing of covering schedules, deposit receipts, pass book / pass sheet, freeing the staff from performing these time-consuming jobs, and enabling them to give more attention to the needs of the customer.
- Signature retrieval facility, assisting in verification of transactions, sitting at their own terminal.

- Avoidance of duplication of entries due to existence of single-point data entry.

2.2 Human Capital Development and Asset growth

2.2.1 Human Capital Development

The origin of human capital goes back to the emergence of classical economics in 1776, and thereafter developed a scientific theory (Fitzsimons, 1999). After the manifestation of that concept as a theory, Schultz (1961) recognized the human capital as one of important factors for a national economic growth in the modern economy. With the emergence and development of human capital as an academic field, some researchers expansively attempted to clarify how the human capital could contribute to socio-political development and freedom (Alexander, 1996; Grubb & Lazerson, 2004; Sen, 1999).

Dae-Bong (2009) emphasize that the concept of human capital can be variously categorized by each perspective of academic fields:

The first viewpoint is based on the individual aspects. Schultz (1961) recognized the human capital as 'something akin to property' against the concept of labor force in the classical perspective, and conceptualized 'the productive capacity of human beings in now vastly larger than all other forms of wealth taken together'. Most of researchers have accepted that his thought viewing the capacity of human being is knowledge and skills embedded in an individual (Beach, 2009). Similar to his thought, a few researchers show that the human capital can be closely linked to knowledge, skills, education, and abilities (Garavan et al., 2001; Youndt et al., 2004). Rastogi (2002) conceptualizes the human capital as 'knowledge, competency, attitude and behavior embedded in an individual'.

There is the second viewpoint on human capital itself and the accumulation process of it. This perspective stresses on knowledge and skills obtained throughout educational activities such as compulsory education, postsecondary education, and vocational education (De la Fuente & Ciccone, 2002, as cited in Alan et al., 2008). Despite the extension of that concept, this perspective neglects that human being would acquire knowledge and skills throughout his/her own experience.

The third is closely linked to the production-oriented perspective of human capital. Romer (1990) refers to the human capital as 'a fundamental source of economic productivity'. Rosen (1999) states the human capital as 'an investment that people make in themselves to increase their productivity'. More recently, Frank & Bemanke (2007) define

that human capital is 'an amalgam of factors such as education, experience, training, intelligence, energy, work habits, trustworthiness, and initiative that affect the value of a worker's marginal product'. Considering the production-oriented perspective, the human capital is 'the stock of skills and knowledge embodied in the ability to perform labor so as to produce economic value' (Sheffin, 2003). Furthermore, some researchers define that human capital is 'the knowledge, skills, competencies and attributes in individuals that facilitate the creation of personal, social and economic well-being' with the social perspective (Rodriguez & Loomis, 2007). Consequently, human capital simultaneously includes both of the instrumental concept to produce certain values and the 'endogenous' meaning to self-generate it. In order to dependently/independently create these values, there is no doubt that leaning through education and training can be an important in terms of defining the concept of human capital. Considering that experience can be included as a category of knowledge, the human capital is a synonym of knowledge embedded in individuals.

2.2.2 Asset growth

Asset growth is an important instrument for the assessment of an organization development. It can be used with other variables like profit, capital structure and any other performance indices for the analysis of result or performance of a company or corporation.

Chen, Yao, Yu and Zhang (2008) in their study on Asset Growth and Stock Returns: Evidence from the Pacific-Basin Markets stated that the relationship between finance and growth has been long debated in academic research, and there is a growing body of empirical evidence that well-functioning financial system contributes positively to a country's economic growth (see, e.g., Demirgüç-Kunt and Levine (2008) for an extensive survey of the literature). At the micro-economic level, an important channel for capital markets or banking systems to facilitate economic growth is to efficiently coordinate financing and investment activities across firms, to the effect that capital flows from firms with low investment opportunities to firms with highly profitable prospects.

Using the U.S. data, however, many studies have found evidence at discordance with micro-level financial efficiency: firms experiencing rapid growth by raising external financing, and making capital investments and acquisitions, subsequently have poor operating performance and disappointing stock returns, whereas firms experiencing contraction via divesture, share repurchase, and debt retirement, subsequently report good operating results and high stock returns.

Cooper, Gulen, and Schill (2008, hereafter CGS) summarize these investment and financing effects by a simple measure of total asset growth. They show that in the U.S. market during the period from 1968 to 2003, firms ranked in the top decile of asset growth underperform firms ranked in the bottom decile by more than 20% in stock returns during the year after ranking. They conclude that the evidence suggests significant market inefficiency, possibly resulting from the over-investment tendency by corporate managers and an excessive-extrapolation bias by investors when they value stocks based on firms' past growth.

In this study, Asset growth is look at from the perspective of Information technology and human capital development.

3.0 METHODOLOGY

3.1 Research design and Sampling Technique

Descriptive survey research design is used for this study. The population is the entire banks in Nigerian Banking Industry. The sample is made up of four banks chosen as representatives of all banking companies domiciled in Nigeria. Purposive sampling method is used to select the samples.

3.2 Data collection and Research Instruments

The data for this research work was obtained essentially from primary and secondary sources. The main primary data was sourced through the use of questionnaire. Primary data was also sourced from semi-structured personal interviews conducted. These interviews were also intended to provide general perceptions of bank employees on the effect of information technology on human capital development and asset growth among the Nigerian banks.

On the other hand, the secondary data were extracted from the annual financial reports of the selected banks. The banks were selected based on personal perception of their level of bank information technology (IT) banking practices. Information extracted from their reports is used alongside the primary information collected through questionnaires to test the hypotheses as formulated.

The primary data used for the study was gathered through the following means; namely questionnaire and personal interview. The instrument contained five (5) items in the first section. The second section contains

twenty two (22) questions. Response to the questions ranges from Strongly Agree (SA); Agree (A); Disagree (D); Strongly Disagree (SD) to Undecided (U) in conformity with likert scale. The instruments were administered personally by the researchers to the respondents.

4.0 DATA PRESENTATION AND ANALYSIS

4.1 Method of Data Analysis

The adopted methods of analysis in this study are in three folds. First, descriptive analyses in form of frequency distribution, percentage ranking, proportion values and analysis of variance (ANOVA) are used to analyze the collected data. Second, correlation test is carried to ascertain the significant interaction between instruments electronic banking system and banks performance. The third analytical method used in the study is the regression analysis. The tests is carried out to examine the relationship that exist between bank spending on information technology, both hardware and software, and human capital development and asset growth. Finally, the tests are carried out using statistical package for social sciences (SPSS, version 15) and STATA (version 12).

4.2 Research Hypotheses

The relevant hypothesis for this study tested and validated in the course of the study are:

Hypothesis I

H₀: Information technology has no effect on the development of Nigerian banks human capital development.

H₁: Information technology has effecton the development of Nigerian banks human capital development.

Hypothesis II

H₀: There is no significant relationship between information technology and asset growth in the Nigerian banking industry.

H₁: There is significant relationship between information technology and asset growth in the Nigerian banking industry.

4.3 Analysis of Result

This section combines the variable identification and analysis as regards the corresponding question, analysis of statistics and results of the formulated hypotheses. The variable identifiers of each of the research instruments for the research study as it relates to specified questions are, information technology (Independent variable), human capital

development (dependent variable) and asset growth (intervening variable). The results of the formulated hypothesis are presented below as thus:

4.3.3 Results of Hypothesis

Hypothesis I

Figure I: Information Technology and Human Capital Development

ANOVA ^a						
Model		Sum of Squares	df	Mean Square	F	Sig.
1	Regression	122.641	1	122.641	549.575	.000 ^a
	Residual	21.869	98	.223		
	Total	144.510	99			

a. Predictors: (Constant), Information Technology
b. Dependent Variable: Human Development

Coefficients ^a						
Model		Unstandardized Coefficients		Standardized Coefficients	t	Sig.
		B	Std. Error	Beta		
1	(Constant)	-.295	.106		-2.786	.006
	Information Technology	1.203	.051	.921	23.443	.000

a. Dependent Variable: Human Development

Discussion on Hypothesis I

The estimated result for information technology and human capital development derived is presented in figure I above which revealed the effect of information technology on human capital development. The analysis of variance (ANOVA) reports that null hypothesis (H_0) is rejected with the result that information technology has significant effect on human development at 5% critical level because the F-calculated with 549.58 is greater than the F-tabulated with a value of 5.27. In assessing the partial significance of the estimated parameter, the t-statistics result (where t-calculated with 23.44 is found greater than the t-calculated of 1.96) confirms with the F-stat result at a 5% significant level. From both test (t-stat and F-stat), the calculated figures are greater than the tabulated values; therefore, null hypothesis (H_0) is rejected and alternative hypothesis (H_1) is accepted. Thus, the Result shows that information technology has a positive relationship with Human Capital Development. It implies that with a unit increase in information technology, Human Development improves by 1.203 units and if

information technology is absent, human development deteriorate by 0.295.

Hypothesis II

Figure 2: Information Technology and Asset Growth

ANOVA ^a						
Model		Sum of Squares	df	Mean Square	F	Sig.
1	Regression	11.671	1	11.671	89.082	.000 ^a
	Residual	12.839	98	.131		
	Total	24.510	99			

a. Predictors: (Constant), Information Technology
b. Dependent Variable: Asset Growth

Coefficients ^a						
Model		Unstandardized Coefficients		Standardized Coefficients	t	Sig.
		B	Std. Error	Beta		
1	(Constant)	.743	.081		9.151	.000
	Information Technology	.371	.039	.690	9.438	.000

a. Dependent Variable: Asset Growth

Discussion on Hypothesis II

The estimated result for information technology and asset growth derived is presented in figure 2 above which revealed the impact of information technology on asset growth. The analysis of variance (ANOVA) reports that null (H_0) Hypothesis is rejected, therefore, information technology has significant effect on asset growth at 5% critical level since the F-calculated with 89.08 is greater than the F-tabulated with a value of 5.27. In assessing the partial significance of the estimated parameter, the t-statistics result (where t-calculated with 9.44 is found greater than the t-calculated of 1.96) confirms with the F-stat result with at 5% significant level.

From both test (t-stat and F-stat), the calculated figures are greater than the tabulated values; therefore, null hypothesis (H_0) is rejected and alternative hypothesis (H_1) is accepted. Consequently, the result shows that information technology has a positive relationship with asset growth. It means that with a unit increase in information technology, asset grows by 0.371 units and if information technology is absent, asset growth remains at 0.743.6

5.0 RESULTS AND FINDINGS

5.1 Summary of findings

This encompasses the analysis of all responses gathered on the field through the questionnaires, interviews and other data collected in the course of the research. The highlights of the findings that are drawn from this research work are given as follows:

1. There is a positive relationship between banks investment in information technology and human capital development and asset growth,
2. The relationship between banks profit and their investment in information technology and human capital development though significant, there are other factors that determines profitability outside information technology and human capital development.
3. Bank performance only increases by half of the total cost or amount spent on information technology i.e. an average action or behavior of financial institutions is determined by technology changes or improvement;
4. Also, bank performance without information technology changes or innovation will bring deviation to financial institutions' profitability and human capital development;
5. Human capital development improves and/or deteriorates if the cost of information technology is increased or decreased respectively;
6. Human capital development has also guaranteed quality of work delivered by banks' employees, tasks challenging and workers' reduction;
7. Cost of cash handling and transfer has been reduced through information technology;
8. Information technology enhances the profitability of financial institutions which also translate to assets growth; and
9. High rate of fraudulent acts are more prevalent and recorded with information technology advancement.

6.0 CONCLUSION AND RECOMMENDATIONS

6.1 Conclusion

From the findings of this study the researcher draws the following conclusion that:

1. Financial institutions should see Information technology as an important factor that guarantees or improves their performance and profitability.

2. Since employees or workers made use of the information technology, they need to be trained not only on both on-job and off-job but also organize trainings and seminars after them;
3. Human capital development with the aid of information technology have been seen as a great tool used towards enhancing financial institutions' performance;
4. Customers find it difficult to adhere to technological advancement due to lack of information, low technical know-how and fraudulent act;
5. Advancement in information technology enhances assets growth among the financial institutions in Nigeria; and
6. A large proportion of profit is spent on asset if technology advancement is not taken into proper consideration.

6.2 Recommendations

The benefits of information technology towards banks' human capital development and asset growth in Nigeria have been recognized in the research study. In order to enhance banks' performance, human capital development and asset growth in the Nigerian banking industry, the following measures are recommended:

1. Banking firms should invest continually in both technology and human resources in order to create premium value in knowledge intensive industries.
2. A long-term perspective is required for corporate information technology and human capital strategies. Managers also need to consider the potential trade-offs between the two important resources.
3. Nigeria banking industry should make concerted efforts to design an internet security framework to check online fraud so that the public can be assured and protected against cyber-attack and fraud.
4. There should be a careful study of the system to determine the number of point of sales terminals that will ensure its smooth running in Nigeria so as to prevent unnecessary friction in the system.
5. Adequate legislation on all aspects of the operations of the cashless system so that both the operators of the system and the public can be adequately protected.

References

- Adam D. (1998): "Financial Intermediation and Economic Growth: Evidence from Nigeria", *Journal of Economic Management*, 5(2), 25-48.
- Adeoti J. O. (2005): "Information Technology Investment in Nigerian Manufacturing Industry: The Progress So Far", *Selected Papers for the 2004 Annual Conference*, Ibadan: Nigerian Economic Society, 213-244.
- Adetayo J. O., Sanni S. A. and Ilori M. O. (1999): *The Impact of Information Technology on Product Marketing: A Case Study of a Multinational Company in Nigeria*. *Technovation*, 19, pp. 691-699.
- Afolabi A.R (2015): *Electronic banking implementation and customer's satisfaction: A Nigerian Banking Sector perspective*, Cambridge Publications and Research International
- Agarwal R. and Tanniru M. (1992): *Assessing the Organisational Impacts of Information Technology*. *International Journal of Technology Management* 7 (9), 626–643.
- Agboola A. A. (2002): "Information Technology, Bank Automation, and Attitude of Workers in Nigerian Banks". *Journal of Social Sciences*, Kamla-Raj Enterprises, Gali Bari Paharwali India.
- Anderson R. G. (1990): *Data Processing*, vol. 2: *Information Systems and Technology*. Pitman Publishing, London.
- Balogun .N(2013): *Information Technology and Profitability of Commercial Banks in Nigeria*.
- Bamhart S. M. and Rosenstein S. (1994): 'Firm Performance and Board Composition: Some New Evidence ', *Managerial and Decision Economics*, vol. 15, no. 4, pp. 329-40.
- Benjamin R. I. (1982): *Information technology in the 1990s: A Long Range Planning Scenario*. *MIS Quarter*, 6, 11-32.
- Beccalli E. (2007): *Does Information Technology Investment improve Bank Performance? Evidence from Europe*. *Journal of Banking and Finance*, 31, pp. 2205-2230.
- Bhagat S. and Jefferis E. (2002): *The Econometrics of Corporate Governance Studies*, MIT Press, Cambridge.

- Bharadwaj A. S. (2000): A Resource-Based Perspective on Information Technology Capability and Firm Performance: An Empirical Investigation. *MIS Quarterly*, 24(1), pp. 169-96.
- Black B. S., Jang, H. and Kim W. (2006): 'Does Corporate Governance Predict Firms' Market Values? Evidence from Korea', *The Journal of Law, Economics & Organizations*, 22(2), pp. 366-413.
- Bonn I. Yoshikawa T. and Phan P. H. (2004): 'Effects of Board Structure on Firm Performance: A Comparison Between Japan and Australia', *Asian Business & Management*, vol. 3, pp. 105-25.
- Brown R. M., Gatian A.W. and Hicks J. O. (1995): Strategic Information Systems and Financial Performance. *Journal of Management Information System*, 11(4), pp. 215–48.
- Brucher H. and Scherngell L. et al. (2003): "Change Management in E-government". *Fachzeitschrift des CC e-Gov der Berner FH*: 11-1
- Brynjolfsson, E. (1993): The Productivity Paradox of Information Technology. *Communication*, 36 (12), pp. 67–77.
- Brynjolfsson E. and Hitt, L. M. (2000): Beyond Computation: Information Technology, Organizational Transformation and Business Performance. *Journal of Economic Perspectives*, 14(4), pp. 23–48.
- Carlson E. D. (1974): Evaluating the Impact of Information Systems. In: Senn, J.A. (Ed.), *Information Systems Management*. Wadsworth Publishing Company, Belmont, CA.
- Chakravarthy B. S. (1986): Measuring strategic performance. *Strategic Management Journal*, 7, 437-458.
- Chan Y. E. (2000): Information Technology Value: the Great Divide between Qualitative and Quantitative and Individual and Organizational Measures. *Journal of Management Information System*, 16(4), pp. 225–61.
- Chen. S, Yao T, Yu T, Zhang. T (2008): Asset Growth and Stock Returns: Evidence from the Pacific-Basin Markets, University of Rhode Island. and University of Arizona.
- Chircu A. M. and Kauffman R. J. (2000): Limits to Value in Electronic Commerce-Related

Information Technology Investments. *Journal of Management Information System*, 17(2), pp. 59–80.

Claessens S. and Fan, J. P. (2002): 'Corporate Governance in Asia: A Survey', *International Review of Finance*, vol. 3, no. 2, pp. 71-103.

Claus V. and Schwill A. (1992): *Encyclopedia of Information Technology*. Ellis Horwood Limited, England.

Computer World. (1990): The Premier 100: High pressure, high stakes. *ComputerWorld (Suppl.)*, October 8, pp. 12-25.

Crowther D. (1996): 'From the Foundation Upwards: Evaluating Business Performance', *Managerial Auditing Journal*, vol. 11, no. 1, pp. 35-47.

Dae-bong. K (2009): Human capital and its measurement, The 3rd OECD World Forum on "Statistics, Knowledge and Policy" Charting Progress, Building Visions, Improving Life Busan, Korea - 27-30 October 2009

Daily C. M. and Dalton, D. R. (1998): 'Does Board Composition affect Corporate Performance? No!', *Directorship*, vol. 24, no. 7, pp. 7-9.

Davis G. D. and Olson, M. H. (1985): *Management Information Systems: Conceptual Foundations, Structure, and Development*. New York: McGraw-Hill.

Deegan C. (2004): *Financial Accounting Theory*, McGraw-Hill Australia Pty Ltd, NSW.

Dehaene A. De Vuyst V. and Ooghe H. (2001): 'Corporate Performance and Board Structure in Belgian Companies' *Long Range Planning*, vol. 34, no. 3, pp. 383-98.

Dewan S. and Min C. K. (1997): The Substitution of Information Technology for other Factors of Production: A Firm Level Analysis. *Management Science*, 43(12), pp. 1660–75.

Epps R. W. and Cereola, S. J. (2008); 'Do Institutional Shareholder Services (ISS) Corporate Governance Ratings Reflect a Company's Operating Performance?', *Critical Perspectives on Accounting*, vol. 19, pp. 1138-48.

Essinger J. (1993): *Managing Technology in Financial Institutions*. London: Pitman.

- Finkelstein S. and D'Aveni R. A. (1994): 'CEO Duality as a Double-edged Sword: How Board of Directors Balance Entrenchment Avoidance and Unity of Command', *Academy of Management Journal*, vol. 37, no. 5, pp. 1079-108.
- Fisher S. (1995): 'Access to Information', *Management Decision* 33(5), pp. 22-28.
- Fuori M. and Gioia, L. V. (1991): 'Computers and Information Processing', Prentice Hall Publishing, New Jersey.
- Gomper, P., Ishii J. and Metrick A. (2003): 'The Corporate Governance and Equity Prices', *The Quarterly Journal of Economics*, no. February, pp. 107-55.
- Haniffa R. and Hudaib, M. (2006): 'Corporate Governance Structure and Performance of Malaysian Listed Companies', *Journal of Business Finance and Accounting*, vol. 33, no. 7 & 8, pp. 1034-62.
- Hanson J. and Narula U., 1990: *New Communication Technologies in Developing Countries*. Lawrence Erlbaum Association Inc., New Jersey.
- Harold B. and Jeff L. (1995). 'Don't Let Technology Pass You By'. *ABA Banking Journal*, Box 986, Omaha, NE, p.73.
- Hermalin B. E., and M.S. Weisbach. (1991): 'The Effects of Board Composition and Direct Incentives on Firm Performance', *Financial Management* 20: 101-113.
- Irechukwu G. (2000): "Enhancing the Performance of Banking Operations through Appropriate Information Technology". *Information Technology in Nigerian Banking Industry*, Spectrum Books, Ibadan, pp. 63-78.
- Johnson B. A., Ott, J. H., Stephenson J. M. and Weberg P. K. (1995). 'Banking on Multimedia', *McKinsey Quarterly*, 2, pp. 94-106.
- King W. R., Grover V., & Hufnagel E. H. (1989): 'Using Information and Information Technology for Sustainable Competitive Advantage: Some Empirical Evidence', *Information and Management*, 17, 87-93.
- Klapper L. F. and Love I. (2004): 'Corporate Governance, Investor Protection, and Performance in Emerging Markets', *Journal of Corporate Finance*, vol. 10, no. 5, pp. 703-28. *Governance*, vol. 11, no. 3, pp. 189-205.

- Kothari S. P. (2001): 'Capital Market Research in Accounting', paper presented to JAR Rochester Conference April 2000.
- Laudon D. P. and Laudon J. P. (1991): Business Information System: A Problem Solving Approach, New York, HBJ, College Publishers 21.
- Longley L. and Shain M. (1982): Dictionary of Information Technology. Macmillan Press Limited, London.
- Lawlor A. (1985): Productivity Improvement Manual. Westport, CT: Quorum Books.
- Lucey T. (1987): Management Information Systems. DP Publications, London.
- Mahmood M. A. and Mann G. J. (1993): Impact of Information Technology Investment: An Empirical Assessment. Accounting Management and Information Technology, 3(1), pp. 23-32.
- Margolis J. D. and Walsh J. P. (2001): People and Profits? The Search for a Link between Company's Social and Financial Performance, Lawrence Erlbaum Associates, Mahwah, NJ.
- Marimuthu .M, Arokiasamy.L and Ismail.M (2009): Human capital development and its impact on firm performance: evidence from developmental economics, Journal of International Social Research, volume 2 / 8 summer 2009.
- Mentzer T. and Gandhi N. (1993): Expert System in Industrial Marketing. Industrial Marketing Management 22 (2), 109–116.
- Mitra S. and Chaya A. K. (1996): Analyzing Cost-Effectiveness of Organizations: The Impact of Information Technology Spending. Journal of Management Information System, 13(2), pp. 29–57.
- Moriarty R. T. and Swartz, G. S. (1989): Automation to Boost Sales and Marketing. Harvard Business Review (January/February), pp. 100–105.
- Morisi T. L. (1996): Commercial Banking Transformed by Computer Technology. Monthly Labor Review, 119(8), pp. 30–36.
- Murdick R. G. Render B. and Russell R. S. (1990): Service Operations Management. Boston, Massachusetts: Allyn and Bacon.
- Obasan, K. A. (2010): Information and Communication Technology and Bank Profitability in

Nigeria. *Australian Journal of Business and Management Research*, Vol. 1(4), pp. 102-107.

Ojo, J.A. T. (2007): "Financial Sector Mal-adaptation, Resource Curse and Nigeria's Development Dilemma", Public Lecture, Covenant University, Ota, Ogun State.

Orlitzky, M., Schmidt, F. L. and Rynes, S. L. (2003): 'Corporate Social and Financial Performance: A Meta-Analysis', *Organization Studies*, vol. 24, no. 3, pp. 403-41.

Ovia, J. (2005); "Enhancing the Efficiency of the Payment System in Nigeria", *CBN Bullion*, Vol. 29(1), pp.8-18.

Porter, M. E. and Miller M. E. (1985): How Information gives you Competitive Advantage. *Harvard Business Review*, pp. 149–160.

Qureshi, M. A. (2007): 'System Dynamics Modelling of Firm Value', *Journal of Modelling in Management*, vol. 2, no. 1, pp. 24-39.

Rappaport A. (1986): *Creating Shareholder Value*, The Free Press, New York, NY.

Rezaee Z. (2009): *Corporate Governance and Ethics*, John Wiley & Sons, Inc, USA.

Sambamurthy V., Bharadwaj, A. and Grover, V. (2003): Shaping Agility through Digital Options: Re-conceptualizing the Role of Information Technology in Contemporary Firms. *MIS Quarterly*, 27(2), pp. 237–63.

Senn J. A. (1982): *Information Systems Management*. Wadsworth Publishing Company, Belmont, CA.

Swierczek F. W. and Shrestha, P. K. (2003): Information Technology and Productivity: a Comparison of Japanese and Asia-Pacific Banks. *Journal of High Technology Management Research*, 14, pp. 269-288.

Sumanth D. J. (1984): *Productivity Engineering and Management: Productivity Measurement, Evaluation, Planning, and Improvement in Manufacturing and Service Organizations*. New York: McGraw-Hill.

The Cambridge Encyclopedia (1990): Cambridge University Press.

Ugwu, L. O., Oyebisis, T. O., Ilori, M. O. and Adagundo, E. R. (2000): *Organisational Impact of Information Technology on the*

Banking and Insurance Sector in Nigeria. *Technovation*, 20, pp. 711-721.

Walter C. (1992); *Dictionary of Information Science and Technology*. Academic Press Inc., London.

Weber Y. and Pliskin N. (1996): The Effects of Information Systems Integration and Organizational Culture on a Firm's Effectiveness. *Information Management*, 30(2), pp. 81–90.

Weir C. M. and Laing, D. (2001): 'Governance Structures, Director Independence and Corporate performance in the UK', *European Business Review* vol. 13, no. 2, pp. 86-94.

Weir C. M., Laing D. and McKnight P. J. (2002): 'Internal and External Governance Mechanisms: Their Impact on the Performance of Large UK Public Companies', *Journal of Business Finance & Accounting*, vol. 29, no. 5 & 6, pp. 579-611.

Woherem E. W. (2000): *Information Technology in the Nigerian Banking Industry*, Spectrum, Ibadan.

Woo, C. Y., and Willard G. (1983): *Performance Representation in Business Policy Research: Discussion and Recommendation*, the 23rd Annual National Meetings of the Academy of Management, Dallas.

APPENDIX A

Table 1: Descriptive Values and Correlation of Variables

Descriptive Statistics					
	Mean	Std. Deviation	N		
Information Technology	1.85	.925	100		
Bank Performance	1.52	.703	100		
Human Development	1.93	1.208	100		
Asset Growth	1.43	.498	100		

Correlations					
		Information Technology	Bank Performance	Human Development	Asset Growth
Information Technology	Pearson Correlation	1	.789 ^{**}	.921 ^{**}	.690 ^{**}
	Sig. (2-tailed)		.000	.000	.000
	N	100	100	100	100
Bank Performance	Pearson Correlation	.789 ^{**}	1	.685 ^{**}	.769 ^{**}
	Sig. (2-tailed)	.000		.000	.000
	N	100	100	100	100
Human Development	Pearson Correlation	.921 ^{**}	.685 ^{**}	1	.655 ^{**}
	Sig. (2-tailed)	.000	.000		.000
	N	100	100	100	100

Asset Growth	Pearson Correlation	.690 ^{**}	.769 ^{**}	.655 ^{**}	1
	Sig. (2-tailed)	.000	.000	.000	
	N	100	100	100	100

** . Correlation is significant at the 0.01 level (2-tailed).

EFFICIENCY AND FINANCIAL DISTRESS PREDICTION IN THE NIGERIAN BANKING INDUSTRY – Ayoola, T. J. & Oyerinde, A. A.

alabiayoolaaca@yahoo.com

waleoyerinde@yahoo.com

Dept. of Management & Accounting
Technical Education
Obafemi Awolowo University, Ile-Ife
Education,

Dept. of Vocational &
Tai Solarin University of
Ijagun, Ijebu-Ode

Abstract

This study investigates the efficiency levels of banks in Nigeria between 2005 and 2012 using Data Envelopment Analysis (DEA). This was with a view to evaluating the reliability of efficiency scores as predictor of financial distress. Secondary data obtained from the annual financial statements of eighteen banks for the period under consideration were used for this study. The study estimates efficiency scores using both input and output-oriented variable return to scale (VRS) of the Intermediation approach. The results were compared with the profit-oriented and worst practice models in order to obtain more robust and reliable results. The results find an increase in banks' efficiency levels over time but witnessed drastic deterioration in 2008 and 2010 financial years which coincided with the global financial crisis. Additionally, the study finds out that efficiency scores can be used as indicators of financial health status of banks and act as a signal of an impending financial crisis point in the Nigerian banking industry. The study concludes that an efficient banking system is better able to withstand negative shocks and contributes to the stability of the financial system.

Keywords: Nigerian banking industry, DEA, efficiency, distress.

1. Introduction

The banking industry plays an increasingly critical role in the development of the financial system, as it serves as a catalyst for economic growth and development through the process of financial intermediation which affects the allocation of savings, thereby improving

productivity (Levine, 2005). As a result of these roles, a properly functioning banking sector is crucial in order to ensure the growth of an economy and the stability of the financial system. National governments, through their regulatory agencies have shown concern towards the proper functioning of the banking industry and have therefore regulated the industry. However, despite the supervision and regulatory roles of government, the industry has been periodically characterized by financial distress thereby resulting in huge loss of shareholders' fund and erosion of public confidence in the system (Hahn, 2007).

Financial distress in the banking industry has been a pervasive phenomenon throughout history and appears to be a concern for most economies because it contributes to a decline in credit and to low gross domestic product (GDP) growth (Farinde, 2013; Allen, Babus & Carletti, 2009). Thus, one of the major concerns in this field of research is the ability to identify early warning signal of financial distress. Banks which cannot recognize the symptoms of distress and take measures at an early stage will run into bankruptcy, which will not only bring about loss to stakeholders, but also affects the stability of social economy (Xin & Xiong, 2011). Over the past decade, several financial distress episodes have shown that the causes of distress may be linked to a variety of variables such as inefficiencies, asset quality issues, improper risk practices, etc (Khalad, Badrul, & Mazila, 2014; Emel, Oral, Reisman & Yolahan, 2003). Empirical evidences have shown that banking remains a highly regulated industry in which substantial in-inefficiencies have been shown to exist (Darrat, Topuz & Yousef, 2002). A firm is said to be inefficient either by producing less than maximum output from a given set of inputs or by using more than the minimum input required for a given level of output (technical inefficient) or by utilizing the wrong mix of input given their prices (allocative inefficient). The issue of bank efficiency has become more important following the 2007-2010 global financial crises and its widespread impact on the stability of the financial system (Chen, 2009) because some studies have argued that an efficient banking sector is better able to withstand negative stocks and contribute to the stability of the financial system. Generally speaking, empirical literature provides mixed evidence on efficiency of banks (Mohanty, Lin & Lin 2013).

Banks have been predominantly assessed by comparing financial ratios related to cost and profitability and this has been criticized *inter alia* on the basis that because bank is a multiple-input and multiple-output organisation, an appropriate multiple criteria evaluation technique is essential to comprehensively and objectively measure its efficiency. Data envelopment analysis (DEA) has been considered as an appropriate and well known approach for measuring the performance of organizations (Wang, Huang, Wu & Liu, 2014; Ncube, 2009; Yen, 2009). This study

therefore examines efficiency trends of Nigerian banks between 2005 and 2012 and evaluates the reliability of efficiency scores as early warning signals for financial distress.

The organisation of the paper is as follows: A selective review of the literature is presented in the following section. The methodology used is described in section 3, analysis of findings is contained in section 4, policy implication in section 5 while section 6 sets out the conclusion and recommendation.

2. Review of Literature

2.1 Conceptual Clarification of Financial Distress

The existence of various situations affecting corporate value and the expectations of stakeholders caused financial distress literature to evolve in confusion and turmoil (Wruck, 1990). The most common terms used to describe the situations of firms facing financial distress are "bankrupt", "failure", "insolvency", "crisis", and "default". The definition of financial distress is diverse and not uniform in literature. It differs from country to country and the economic, laws, and socio-cultural environment of a country must be considered in the definition of financial distress (Less & Tung, 2007). In a corporate context, financial distress is a condition that is characterized by a substantial impairment of a firm's ability to pay claims that are due or required to the point that default is possible or even likely (Kane, Richardson & Valery, 2000). It is a term in corporate finance used to indicate a condition when promises to creditors of a company are broken or honoured with difficulty (Balcaen & Ooghe, 2006). It is a severe liquidity problem that cannot be resolved without a sizeable rescaling of the entity's operations or structure.

According to Alashi (2002), a bank is said to be in distress when it shows most of the following symptoms: gross under-capitalization in relation to the level of business, high level of non-performing loans to total loans, illiquidity as reflected in a bank's inability to meet customers' cash withdrawal and/or a persistent overdrawn position with the central bank, low earnings resulting in huge operational losses, weak management as reflected by poor asset quality, insider abuse, inadequate internal controls, fraud, boardroom squabbles, among other factors. This study adopts the definition of financial distress as used by Gonzalez-Hermosillo (1999) and Fidrmuc & Sub (2009) which states that a bank is deemed distressed if it undergoes one of the following conditions: the bank was acquired by other financial institution as a last resort; the bank's operations were temporarily suspended by the government; the bank was recapitalized by regulatory authority specifically created to address the crisis; the bank required a liquidity injection (direct state

bailout) from the monetary authorities; the bank was forced into a compulsory merger or takeover; and/or the bank was nationalized in order to prevent its default.

2.2 Efficiency Concepts and Measurement in Banking

Efficiency in banking can be distinguished between allocative and technical efficiency. Allocative efficiency is the extent to which resources are being allocated to use with the highest expected value while technical efficiency is the extent to which a given set of outputs is produced using the smallest possible amount of inputs (Ncube, 2009). When measuring efficiency of financial institutions, a fundamental decision to be made is the determination of efficiency concept to use, some of the important efficiency concepts in use are cost and profit models. In the determination of efficiency model, a key decision is the selection of appropriate inputs and outputs. There are about four broad approaches that can be used to determine the input and output variables and these are the intermediation, production, profit and most recently worst – practice approaches. Under the intermediation approach, banks are treated as collectors of funds, which are then intermediated to loans and other assets. The total balance of deposits and loans is used as a measure for outputs, operating and interest costs are used to measure total costs (Yen, 1996). This approach is best suited for analyzing firm-level efficiency. Under the production approach, a bank is viewed as a producer of deposits and loans using labour, capital and materials (Chen, 2009). There are two general approaches that can be used to measure the efficiency of an entity and these are the parametric and the non-parametric (Linear programming) approach. While the parametric techniques include the stochastic frontier method, distribution-free method and the Thick frontier approach, the non-parametric techniques include data envelopment analysis and the free disposal hull analysis (Chang, 2014).

According to Stavarek & Repkova (2011), the term “DEA” was first introduced by Charnes, Cooper & Rhodes (CCR) (1978) based on the research of Farrel (1957). CCR model is the basic DEA model but which was modified by Banker Charnes & Cooper (BCC) (1984) and became the BCC model which accommodates variable returns to scale (VRS). The CCR model presupposes that there is no significant relationship between the scale of operations and efficiency by assuming constant returns to scale (CRS) and it delivers the overall technical efficiency. The CRS assumption is only justifiable when all DMUS are operating at an optimal scale. However, firms or DMUs in practice might face either economies or diseconomies to scale. Thus, if one makes the CRS assumption when not all DMUS are operating at the optimal scale, the computed measures of

technical efficiency will be contaminated with scale inefficiencies. Banker et al. (1984) extended the CCR model by relaxing the CRS assumption. The resulting BCC model was used to assess the efficiency of DMUs characterized by VRS. The VRS assumption provides the measurement of pure technical efficiency (PTE) which is the measurement of technical efficiency devoid of the scale inefficiency (TE) effects. DEA is a methodology for measuring the relative efficiencies of a group of DMUs that use multiple inputs to produce multiple outputs. In the conventional DEA, performances of DMUs are measured from the optimistic point of view, namely, each DMU seeks a set of weights that is most favourable to itself to maximize its efficiency. The efficiency measured in this way is called the best relative efficiency or the optimistic efficiency. If the best relative efficiency of a DMU is equal to one, the DMU is said to be DEA efficient or optimistic efficient; otherwise, it is said to be DEA non-efficient. On the other hand, the performance of DMUs can also be measured from the pessimistic point of view or the worst – practice models. They take values greater than or equal to one. If the value of the worst relative efficiency of a DMU is one, the DMU is said to be pessimistic inefficient otherwise, it is said to be pessimistic non-inefficient (Azizi & Wang, 2013).

Bank efficiency has long been a subject of many studies. Most of the studies have focused on developed countries, while studies on developing countries are a recent phenomenon. Studies in sub-Saharan African banks are relatively few, partly due to the low level of financial development, small number of banks, limited market activities and lack of quality data (Chortareas, Girardone, & Ventouri, 2013). However, it is worth noting that some middle-income countries in sub-Saharan Africa have developed relatively complex financial systems, with commercial banks as the core financial intermediaries. The availability of data has made it possible to understand how banks operate, and to investigate the major factors that can improve efficiency (Chen, 2009).

Since the deregulation of the Nigerian banking system, a number of studies have investigated bank efficiency. One motivation behind these studies is that the stability of the banking system depends on the efficiency level of banks, as measured by a bank's ability to operate close to the best-practice frontier (Delis & Papanikolaou, 2009). Some of the studies evaluated bank efficiency scores (e.g., Usman & Fadipe, 2014; Muhammad & Muhammad, 2013; Obafemi, 2012; Olaosebikan, 2009; Tanko, 2008); determinants of banks' efficiency (e.g., Muhammad & Muhammad, 2013; Oke & Poloamina, 2012); impact of merger and acquisition on banks' efficiency (e.g., Owolabi & Ajayi, 2013; Elumilade, 2010); and competition and efficiency of commercial banks in Nigeria (Ajisafe & Akinlo, 2014). Our review of efficiency studies in Nigeria

showed that to the best of our knowledge, no study has evaluated efficiency scores as early warning signals of financial distress. While some of the studies adopted above adopted statistical and econometric models, others adopted DEA. DEA has been considered superior to other methods in performance evaluation because it is a non-parametric, deterministic method and therefore does not require a priori assumptions about the analytical form of the production function unlike regression model. Instead, it constructs the best practice production function solely on the basis of observed data, and therefore the possibility of mis-specification of the production technology is zero (Jemric & Vujcic, 2002). Another advantage is that while regression analysis relies on central tendencies and assumes that a single estimated regression equation applies to each observation vector, DEA is based on extreme observations and analyses each vector (DMU) separately producing individual efficiency measures relative to the entire set under evaluation (Premachandra, Chen, & Watson, 2011). DEA does not need a large sample size for performance evaluation usually required by such statistical and econometric approaches (Tsolas & Charles, 2015; cook, Tone, & Zhu, 2014). A further review of the studies that adopted DEA examines the intermediation approach without considering alternative models such as the profit and worst-practice models (Jayaraman & Srinivasan, 2014; Delis, Koutsomanoli-Filippaki, Staikouras, & Gerogiannaki, 2008). Consequently, the study of efficiency in Nigerian banks is unique for many reasons. First, Nigerian banks have gone through several reforms with the objective of enhancing efficiency and productivity, key among the reform was the ₦25 billion recapitalisation exercise which ended in December, 2004. Second, Nigeria is one of the largest and fastest growing economies in sub-Saharan Africa. Thirdly, studies of efficiency have typically examined the cost and technical efficiency without the consideration of profit and worst-practice models. Against this background, this paper deems it necessary to juxtapose cost, profit and worst-practice models to address financial distress.

2.3 DEA Models

This study examines three DEA models. The first model developed by Charnes et al. (1978) was called the CCR model. The second model was named the BCC model, developed by Banker (1984) and the third model is the Worst-practice model. The CCR model is built on the assumption of constant returns to scale (CRS), whereas the BCC model is built on the assumption of variable returns to scale (VRS). The relative efficiency evaluated by the CCR model is the overall efficiency score and the one estimated by the BCC model is the pure technical efficiency score. These scores are typically defined on the interval (0, 1). The specification of the

three models as computed by Chang (2014) and Yu, Barros, Tsai, & Liao (2014) and adopted are as follows:

The CCR Model

According to Charnes et al. (1978), the fractional form of the CCR linear programming model is given as follows:

$$\eta_O^{MA} = \frac{\sum_{r=1}^S u_r y_{rO}}{\sum_{i \in I_D} v_i x_{iO}}$$

Subject to

$$\frac{\sum_{r=1}^S u_r y_{rj} - \sum_{i \in I_F} v_i (x_{ij} - x_{iO})}{\sum_{i \in I_D} v_i x_{ij}} \leq 1 \quad j \in \{1, \dots, N\}$$

$u_r, v_i \geq 0 \quad \forall r \in \{1, \dots, S\}$ and $i \in I_D$

$v_i \geq 0 \quad \forall i \in I_F \dots \dots \dots (1)$

Where u and v are the weights of the input and output, i and r are output and input of DMU. According to Liu et al. (2010), the model is difficult to solve because of its fractional model. Therefore, the dual linear model is required to reduce the number of constraints and facilitate solving the linear problem. However, the model is modified based on the Cooper' modification (Cooper et al., 2000).

$$\text{Max } \phi_o + \varepsilon \left(\sum_{r=1}^S S_{ro}^- + \sum_{i=1}^M S_{io}^+ \right)$$

Subject to

$$\sum_{j=1}^N \gamma_j y_{rj} - S_{ro}^- = \phi_o y_{rO}, r \in \{1, \dots, S\}$$

$$\sum_{j=1}^N \gamma_j y_{ij} + S_{io}^+ = x_{iO}, i \in \{1, \dots, M\}$$

$\phi_o, \gamma_j, S_{ro}^-, S_{io}^+ \geq 0 \dots \dots \dots (2)$

Where, ϕ_o is the measure of efficiency of the DMU "O" in the set of $j = 1, 2, \dots, n$ DMUs rate related to other, ε is e an infinitesimal positive number used to make both the input and output coefficients positive; S_{ro}^- is the slack variables for input constraints, which are all constrained to be

non-negative, and S_{io}^+ is the slack variables for output constraints, which are all constrained to be non-negative. γ_j is the dual weight assigned to DMUs.

The BCC-Model

According to Banker (1984), the BCC-model enables expression of the (input) technical efficiency measure for DMU. Thus, it has the same equation employed in the CCR-model, but with convexity constraint for modification.

$$\text{Max } \phi_o + \varepsilon \left(\sum_{R=1}^S S_{ro}^- + \sum_{r=1}^M S_{io}^+ \right)$$

Subject to

$$\sum_{j=1}^N \gamma_j y_{rj} - S_{ro}^- = \phi_o y_{ro}, r \in \{1, \dots, S\}$$

$$\sum_{j=1}^N \gamma_j y_{rj} + S_{io}^+ = x_{io}, i \in \{1, \dots, M\}$$

$$\sum_{j=1}^N \gamma_j = 1$$

$$\phi_o, \gamma_j, S_{ro}^-, S_{io}^+ \geq 0. \dots\dots\dots (3)$$

If convexity constraint $\sum_{j=1}^N \gamma_j = 1$, it implies that the DMU "O" is currently operating at the most productive scale size for the discretionary inputs, given the fixed level of non-discretionary inputs. However, if $\sum_{j=1}^N \gamma_j > 1$, it implies that DMU "O" is operating at a scale greater than the most productive scale size for the discretionary inputs. Conversely, if $\sum_{j=1}^N \gamma_j < 1$ then DMU "O" is operating in the increasing return to scale region, at a scale smaller than the most productive scale size for the discretionary inputs, given the fixed level of non-discretionary inputs (Banker, 1984).

Worst-practice Model

The purpose of the worst-practice model is different with BCC model since the former is to examine how bad a DMU's performance could possibly be in a worst scenario. Hence, the objective function in this model is to minimize the efficiency score of DMU. Here, the DMUs with the worst efficiency are located on the worst-practice frontier and the DMUs with more efficiency are far from the worst-practice frontier. For establishing a worst-practice frontier, a worst-practice model is as shown below:

$$\begin{aligned}
 \text{Min } h_i &= \frac{\sum_{t=1}^T u_t y_i^t - u_0}{\sum_{s=1}^S v_s x_j^s} \\
 \text{s.t. } &\frac{\sum_{t=1}^T u_t y_i^t - u_0}{\sum_{s=1}^S v_s x_j^s} \geq 1, i = 1, \dots, N, \\
 &v_s, u_t \geq 0, s = 1, \dots, S, t = 1, \dots, T, \\
 &u_0 \in \mathbb{R}. \dots\dots\dots (4)
 \end{aligned}$$

We translate the fractional programming in Equation (4) into the following linear programming as follows:

$$\begin{aligned}
 \text{Min } h_i &= \sum_{t=1}^T u_t y_i^t - u_0 \\
 \text{s.t. } &\sum_{s=1}^S v_s x_j^s = 1 \\
 &\sum_{s=1}^S v_s x_j^s - \sum_{t=1}^T u_t y_i^t + u_0 \leq 0, j = 1, \dots, N, \\
 &v_s, u_t \geq 0, s = 1, \dots, S, t = 1, \dots, T, \\
 &u_0 \in \mathbb{R}.
 \end{aligned}$$

The duality solution of the model is used to measure the efficiency score θ_i for DMU_{*i*} is shown as:

$$\begin{aligned}
 1/h_i &= \text{Max } \varphi_i \\
 \text{s.t. } &\sum_{j=1}^N \lambda_j y_j^s - \varphi x_i^s \geq 0, s = 1 \dots S, \\
 &\sum_{j=1}^N \lambda_j y_j^t - y_i^t \leq 0, t = 1, \dots, T, \\
 &\sum_{j=1}^N \lambda_j = 1, \text{ for } \forall \lambda_j \geq 0.
 \end{aligned}$$

In the worst-practice model, the optimal efficiency score φ_i^* of DMU_i is not less than 1. And the more efficient the DMU is, the higher the efficiency score will be. $\varphi_i^* = 1$ represents that the DMU_i is the worst efficient.

2.4 The Nigerian Banking System and Financial Distress

The history of Nigerian banking distress can be conveniently divided into three era namely: the era between 1940s and 1950s; 1989 & 1998; and 2007 and 2009. The Nigerian economy witnessed a rapid growth of indigenous banks between 1947 and 1952. By 1954, 21 out of the indigenous banks had collapsed. The failures were attributed to mismanagement of assets, lack of adequate capital, lack of managerial expertise and untrained personnel, among other factors (Adekanye, 1983; Osaze & Anao, 1990). This failure, among other issues culminated into the enactment of the banking ordinance of 1957 and the establishment of the Central Bank of Nigeria (CBN) in 1959 (Umoh, 2004). The implementation of the Structural Adjustment Programme (SAP) in 1986 coupled with the deregulation of the financial sector facilitated a dramatic increase in the number of banks which were set up largely to take advantage of arbitrage opportunities in the foreign market rather than undertake more conventional and traditional banking business (Mainoma, 2010; Ogunleye, 2002; Nworji, Adebayo & David, 2011; Aruwa, 2007).

The second financial crisis symptom was first observed in 1989 when there was mass withdrawal of deposit by government agencies, this situation worsened until 1993 when it led to the collapse of the inter-bank market and spread to all segments of the financial system (Sanusi, 2010; Ailemen, 2003; Heiko, 2007). The CBN in 2004 announced a consolidation exercise for the banking system because of the structural deficiency of the financial sector. The banking sector as at that time was bedevilled with perennial problems such as capital deficiency, high incidence of non-performing loans, poor asset quality, weak management, etc. The banking reform announced by the CBN was designed to strengthen the industry, make it efficient and position it for international competitiveness (Osaze, 2011; Sanusi, 2011; Umoren & Olokojo, 2007; Soludo, 2004).

In the aftermath of the global financial crisis that started in USA in 2007, systematic crisis showed up in the industry with CBN providing support to the industry, while the crisis can be partly explained by the global financial crisis, it was evident that the banks contributed in no small measures to the crisis. During this period, the CBN ordered a special investigation into the financial condition of the 24 banks. The examination showed that 9 banks were in 'grave situation', Oceanic Bank, Union Bank, Intercontinental Bank, Bank PHB, Afribank, Finbank,

Equitorial Trust Bank, Spring Bank and Wema Bank. Consequently, the CBN dismissed the Chief Executive Officers (CEO) of 8 banks (with the exception of Wema Bank on the ground that the bank reconstructed their board shortly before the CBN investigation and had injected fresh capital into the bank) and injected Tier II capital amounting to US \$ 4.1 billion into the banks (Fadare, 2011; Sanusi, 2010).

3. Methodology

3.1 Data

The population of the study comprises banks between 2005 and 2012 which varies between 25 in 2005 and 20 as at 2012. The sample includes an unbalanced panel data for 18 banks between 2005 and 2012 with a total of 144 observations. The sample consists of 5 distressed banks (Oceanic Bank, Intercontinental Bank, Afribank, Union Bank, and Bank PHB) and 13 healthy banks. Data were obtained from the annual financial reports of banks in Nigeria.

3.2 Method

In the study, DEA with variable returns to scale (VRS) was used to compute efficiency scores. The choice of VRS over constant returns to scale (CRS) is justified on the grounds that not all DMUs, i.e., banks are operating at an optimal scale due to imperfect competition and financial constraints. The CRS assumption is only justifiable when all DMUs are operating at an optimal scale. However, banks in practice may face either economies or diseconomies of scale. Thus, if one makes the CRS assumption when not all DMUs are operating at the optimal scale, the computed measures of technical efficiency will be contaminated with scale efficiency (Fadzlan & Muzafar, 2012). The intermediation approach in both input and output – oriented models was adopted and this is considered appropriate when banks operate as independent entities. However, the intermediation approach was complemented by profit and worst – practice models in order to have a robust analysis.

It is well known that DEA is sensitive to variable selection. Typically, the choice and the number of inputs and outputs, and the DMUs determine how good of a discrimination exists between efficient and inefficient units. As the number of variables increases, the ability of DEA to discriminate between DMUs decreases. Cooper, Seiford, & Tone (2007) suggested 3 times the number of DMUs as there are input and output variables (i.e., $3 \times \text{number of inputs} + \text{the number of outputs} < \text{number of DMUs}$). Thus, to preserve the discriminating power of DEA, the number of inputs and outputs for each model are kept at a reasonable level. Another issue pertaining to input and output selection for banking

efficiency measures involves handling bad loans or non-performing loans (NPLs). Prior studies (e.g., Wang, Huang, Wu, & Liu, 2014) have shown that NPLs should be treated as a bad or undesirable output. This study therefore includes loan loss provision as an undesirable output in both intermediation and worst-practice models in line with Fukuyama & Weber (2010) who affirm that it is more appropriate to treat loan loss provision as an undesirable output rather than as an input of a bank's final output.

3.3 Model

The study adopts the BBC-VRS and the worst-practice models as shown below:

The BCC-Model

$$\text{Max } \phi_o + \varepsilon \left(\sum_{R=1}^S S_{ro}^- + \sum_{r=1}^M S_{io}^+ \right)$$

Subject to

$$\sum_{j=1}^N \gamma_j y_{rj} - S_{ro}^- = \phi_o y_{ro}, r \in \{1, \dots, S\}$$

$$\sum_{j=1}^N \gamma_j y_{rj} + S_{io}^+ = x_{io}, i \in \{1, \dots, M\}$$

$$\sum_{j=1}^N \gamma_j = 1$$

$$\phi_o, \gamma_j, S_{ro}^-, S_{io}^+ \geq 0. \dots\dots\dots (3)$$

If convexity constraint $\sum_{j=1}^N \gamma_j = 1$, it implies that the DMU "O" is currently operating at the most productive scale size for the discretionary inputs, given the fixed level of non-discretionary inputs. However, if $\sum_{j=1}^N \gamma_j > 1$, it implies that DMU "O" is operating at a scale greater than the most productive scale size for the discretionary inputs. Conversely, if $\sum_{j=1}^N \gamma_j < 1$ then DMU "O" is operating in the increasing return to scale region, at a scale smaller than the most productive scale size for the discretionary inputs, given the fixed level

of non-discretionary inputs (Banker, 1984).

Worst-practice Model

$$\begin{aligned} \text{Min } h_i &= \frac{\sum_{t=1}^T u_t y_i^t - u_0}{\sum_{s=1}^S v_s x_j^s} \\ \text{s.t. } & \frac{\sum_{t=1}^T u_t y_i^t - u_0}{\sum_{s=1}^S v_s x_j^s} \geq 1, i = 1, \dots, N, \\ & v_s, u_t \geq 0, s = 1, \dots, S, t = 1, \dots, T, \\ & u_0 \in \mathbb{R}. \end{aligned} \quad \dots \quad (4)$$

We translate the fractional programming in Equation (4) into the following linear programming as follows:

$$\begin{aligned} \text{Min } h_i &= \sum_{t=1}^T u_t y_i^t - u_0 \\ \text{s.t. } & \sum_{s=1}^S v_s x_j^s = 1 \\ & \sum_{s=1}^S v_s x_j^s - \sum_{t=1}^T u_t y_i^t + u_0 \leq 0, j = 1, \dots, N, \\ & v_s, u_t \geq 0, s = 1, \dots, S, t = 1, \dots, T, \\ & u_0 \in \mathbb{R}. \end{aligned}$$

The duality solution of the model is used to measure the efficiency score θ_i for DMU_{*i*} is shown as:

$$\begin{aligned} 1/h_i &= \text{Max } \varphi_i \\ \text{s.t. } & \sum_{j=1}^N \lambda_j y_j^s - \varphi x_i^s \geq 0, s = 1 \dots S, \\ & \sum_{j=1}^N \lambda_j y_j^t - y_i^t \leq 0, t = 1, \dots, T, \\ & \sum_{j=1}^N \lambda_j = 1, \text{ for } \forall \lambda_j \geq 0. \end{aligned}$$

In the worst-practice model, the optimal efficiency score φ_i^* of DMU_{*i*} is not less than 1. And the more efficient the DMU is, the higher the efficiency score will be. $\varphi_i^* = 1$ represents that the DMU_{*i*} is the worst efficient. In the discrimination of inefficient banks, we adopted the method of Gulati (2011) and Kumar & Gulati (2008) that used quartiles in classifying the banks into categories. The classification is as follows:

Category I: Quartile 1-25% is known as the “most inefficient” group;

Category II: Quartile 26-50% is known as the “highly inefficient” group; while

Category III: Quartile 51-99% is the “marginally efficient” group.

The classification of banks in category I and II groups will be adjudged worst performers and as early warning signals for financial distress.

4. Analysis of Findings

4.1 Pre-estimation Tests

The selection of inputs and outputs for this study is based on the intermediation approach but also complemented with both the operating and worst-practice approaches. The output and the input variables of the three approaches are as shown in Table 4.1. These sets of variables are those considered important by the banking industry. DEA results rely heavily on the set of input and output variables that are used in the analysis. The attention to variable selection is particularly crucial since the greater the number of input and output variables, the less constrained are the model weights assigned to the inputs and outputs, and the less discerning are the DEA results (Jenkins & Anderson, 2003). This study applies the rule proposed by Cooper, Seiford & Tone (2007) and adopted a total of 5 variables for intermediation and worst-practice models and 4 variables for the operating profit model.

Table 4.2 presents the descriptive statistics of the input and output variables of the study. A preliminary investigation of the summary statistics of all banks reveals that the distribution of the input and output variables are positively skewed to the right with a further implication that the distribution may be affected by positive outliers. In a normal or symmetrical distribution, skewness =0, while positive skewness will result if a distribution is skewed to the right (i.e., mean > median) and finally, a negative skewness will result if a distribution is skewed to the left (i.e., mean < median) (Garson, 2012). A further classification of the banks' data into healthy banks (represented by dis_score 0) and the distressed banks (represented by dis_score 1) is not different from the preliminary assessment of all the banks as one entity.

A pre-processing procedure is performed on the original data set. The results of exploratory data analysis in the previous sub-section indicate that there may be some accounting data observations which are severe outliers. DEA efficiency scores are computed based on the concepts of considering extremely superior performance and where the extreme performance was occasioned by the presence of outliers, wrong inference will be made because DEA efficiency scores are very sensitive to the presence of outliers. Hence, of fundamental importance in DEA is the identification of outliers in the data (Dang & Serfling, 2010). Blocked Adaptive Computationally Efficient Outlier Nominators (BACON) algorithm

proposed by Billor, Hadi, & Velleman (2000) provides an efficient way to detect outliers in multivariate data. The bacon command provides an answer to the question of outlier identification in multivariate data (Weber, 2010). The results show an absence of outlier at 5, 10 and 15 percentile respectively of chi-squared distribution which is used as a threshold to separate outliers from non-outliers.

Table 4.1: List of inputs and outputs

	Inputs	Outputs
Intermediation approach	1. Deposits	1. Loan
	2. Interest expense	2. Interest revenue
		3. Loan loss provision
Operating profit approach	1. Interest expense	1. Interest revenue
	2. Staff cost	2. Non-interest revenue
Worst-practice approach	1. Deposit	1. Gross loans
	2. Profit before tax	2. Non-performing loan
		3. Loan loss provision

Source: Toci & Hashi, 2013; Chang, 2014; Chen, 2012, Wanke, Barros, & Faria, 2015

Table 4.2 Descriptive statistics

Variables	Number	Mean	Median	SD	Min	Max
Deposits	144	465,077.50	337,522.50	406,131.00	12,380.00	2,171,807.00
Interest expense	144	21,583.20	14,155.00	19,312.34	1,324.00	82,836.00
Interest	144					

revenue		55,201.5 5	38,698.5 0	48,928.2 4	1,433.0 0	257,325.0 0
Loans	144	279,337. 10	180,734. 00	264,708. 90	8,151.0 0	1,394,690 .00
Loan loss provision	144	30,273.8 5	11,851.5 0	68,502.2 8	720.00	463,610.0 0

4.2 Efficiency Trends between 2005 and 2012

Table 4.3 and Figure 4.1 present the efficiency scores of the Nigerian banking industry between 2005 and 2012. The results show an increasing trend in efficiency scores over the period under consideration. The increasing trend may be attributable to the success of the consolidation exercise of 2004 that forced the bank to recapitalise to the tune of N25 billion. However, there was a drastic reduction in the average efficiency score for 2010 and this may be attributable to the 2009-2010 global financial crises that started in the United States of America (USA).

Table 4.3: Efficiency Scores between 2005 and 2012

Dmu	2005	2006	2007	2008	2009	2010	2011	2012
Oceanic	0.7162	0.788988	1.0000	1.0000	1	0.80338		
Inter	0.7034	1.0000	1.0000	0.911177	1	0.564219		
Afri	1.0000	1.0000	1.0000	0.905562	1	0.703177		
Union	1.0000	1.0000	1.0000	0.8747	0.969764	0.795563	0.90516	1
Phb	1.0000	0.577481	0.620332	0.691596	1	0.572134		
Wema	0.8355	1.0000	1.0000	1.0000	1	1	1	1
Unity	1.0000	1.0000	1.0000	1.0000	0.931247	0.846793	0.843836	1
Gtb	0.8913	0.745312	0.903679	1.0000	1	1	1	1
zenith	0.9241	1.0000	1.0000	1.0000	1	0.943138	0.934376	0.94693
access	1.0000	1.0000	1	0.863936	0.834936	1	1	0.962748
fidelity	1.0000	0.784043	0.721673	1.0000	1	0.875483	0.650202	0.933561
fcmb	0.7832	0.655678	0.856926	1.0000	1	1	0.918852	0.825103
skye	1.0000	0.900044	0.899067	0.767784	0.764924	0.880917	1	1
eco	0.9903	1.0000	0.972354	0.807904	0.938668	0.926621	0.76714	1
uba	0.8960	1.0000	1.0000	0.947288	1	0.751872	0.725325	0.645185
first	1.0000	1.0000	1.0000	1.0000	1	1	1	1
diamond	0.8380	0.857911	0.922358	0.814864	0.772261	1	1	1
sterling	0.5657	0.808831	0.811456	1.0000	1	0.844542	1	0.887885
AVERA GE	0.89 69	0.895 5	0.928 2	0.921 4	0.956 2	0.861 5	0.910 3	0.943

Figure 4.1: Efficiency Trend between 2005 and 2012

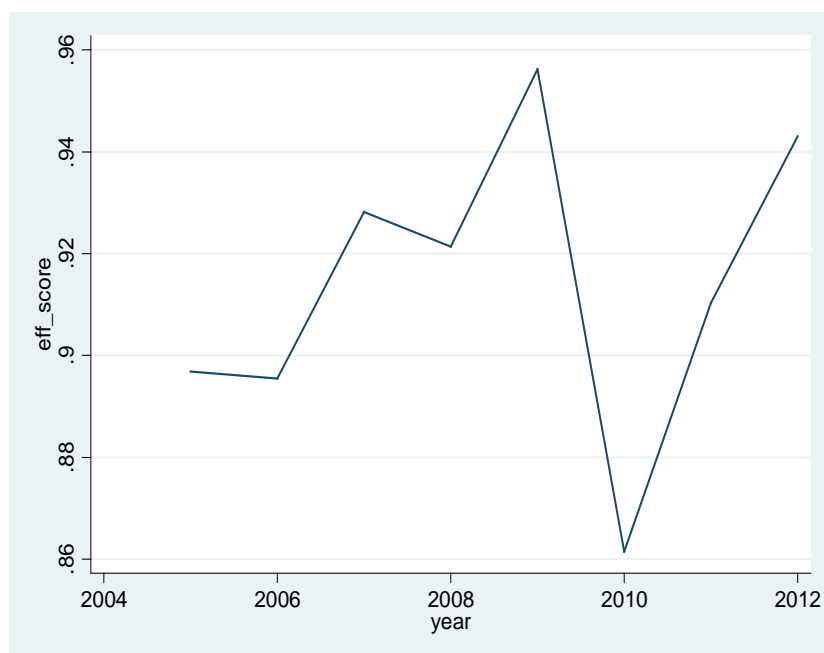

4.3 Efficiency Scores as signals of Financial Distress

The application of DEA in 2005 sample of 18 banks as efficient since they have efficiency score of 1. These banks together define the best practice or efficient frontier and thus, form the reference set for the inefficient banks. The remaining 10 banks have efficiency scores less than 1 which means that they are technically inefficient. Two (2) banks representing 40% of the 5 sampled financially distressed banks are adjudged 'distressed' by DEA analysis. The situation was the same in 2006 as two banks (representing 40%) were adjudged as being in the worst performers' category. In 2007, the situation was different as only one bank (representing 20%) was adjudged distressed. The situation became worse in 2008 as four out of the five banks (representing 80%) were adjudged distressed by DEA. It was however surprising that none of the banks was adjudged distressed by DEA in 2009 and this may be attributable to so many factors. In 2010, all the 5 banks (representing 100%) were adjudged distressed by DEA.

The results of the analysis above validate the high relevance of efficiency screening for early warning signals of financial distress in commercial banks. The results show that the banks' ranking based on relative efficiency score possesses the ability to predict the risk of financial distress. A monitoring of the ranking of the distressed banks in the year preceding the occurrence of their failure shows that two years prior to their failure, these banks were already placed in the distress group. The results thus underlie the findings of Berger & Humphrey (1992), Barr & Siems (1994), and Wheelock & Wilson (1995), which conclude that failing banks tend to locate far from the efficiency frontier.

In this case, the vast majority of failed banks (100%) were in the worst performer category two years prior to failure.

4.4 Post-estimation Tests

To test whether the efficiency differences between the healthy and distressed banks are statistically significant or not, we applied three non-parametric tests which do not invoke the normality assumption. These tests are the Wilcoxon Mann-Whitney test, Kruskal-Wallis test and the Kolmogorov-smirnov test. The Mann-whitney test compares the two sample distributions of efficiency on the basis their central tendencies, as measured by the median while the remaining two tests, Kruskal-wallis and kolmogorov-smirnov tests compare the entire structures of the distribution and not just the central tendency (Gulati, 2011). A Wilcoxon-Mann-Whitney test was run to determine whether there was a statistically significant mean difference between the efficiency scores of healthy and distressed banks. The results suggest that there is no statistically significant difference between the two classification of banks ($z=1.032$, $p=.3019$). so we fail to reject the null hypothesis(95% confidence level) that population are the same. The robustness of this finding was corroborated by both Kruskal-wallis and the Kolmogorov-smirnov tests with the probability being 0.3374 and 0.163 respectively.

5. Policy Implication

It has been well documented in literature that the efficiency of banking system is germane to the performance of the entire economy because only an efficient system guarantees the smooth functioning of the nation's payment system and effective implementation of the monetary policy (Gulati, 2011). The efficiency of banking system bears direct implications for social welfare in the sense that the society benefits by enjoying more banking services at a lower cost when the banking system is efficient (Valverde, Humphrey & Fernandez, 2003). The information obtained from banking efficiency analyses can be used to inform government policies by assessing the effects of various reforms on efficiency; rank the banks according to their ability to withstand shocks; and improve managerial performance by identifying 'best practices' and 'worst practices' associated with high and low measures of efficiency (Gulati, 2011; Berger & Humphrey, 1997).

6. Conclusion and Recommendation

This study provides information of the trend in efficiency scores in Nigerian banking sector during the period 2005-2012 using. The results also show the probability of using efficiency scores as distress warning

signals by adopting the cost, profit and worst-practice models. DEA is a useful method for measuring the efficiency of DMUs. Rather than assuming CRS, this paper adopts a more realistic assumption that provides more information for analysis, VRS. Our results show that those less technically efficient firms are at greater risk of becoming financially distressed than more technical efficient firms.

In terms of using efficiency as the only predictor, our results show that the input-oriented model performs better in correctly classifying the financially distressed banks. The results of this study confirm that studies on efficiency can provide signals on the health of the financial industry. They can help to identify efficiency sources that could either strengthen or harm the performance of the banking industry.

References

- Abiola, R. (2003). Effects of Bank Distress on the Economy: The Nigerian case. *The Nigerian Banker*.
- Aileman, I. (2003). Bank Distress: Concepts, Causes and Magnitude, Role of Trade Union and Bank Management. *The Nigerian Banker*.
- Ajisafe, R.A. & Akinlo, A.E. (2014). Competition and Efficiency of Commercial Banks: An Empirical Evidence from Nigeria. *American Journal of Economics*, 4(1), 18-22.
- Alashi, S. (2002). Banking Crisis: Its Causes, Early Warning Signal and Resolution. *CBN Conference Proceedings on Enhancing Financial Sector Soundness in Nigeria*. Lagos: Central Bank of Nigeria.
- Azizi, H. & Wang, Y. (2013). Improved DEA Models for Measuring Interval Efficiencies of Decision- Making Units. *Measurement*, 46, 1325-1332.
- Berger, A. & Humphrey, D. (1997). Efficiency of Financial Institutions: International Survey and Directions for Future Research. *European Journal of Operational Research*, 98(2), 175-212.
- Berger, A.N. & DeYoung, R. . (1997). Problem Loans and Cost Efficiency in Commercial Banks. *Journal of Banking and Finance*, 21.
- Berger, S., Forsund, F., Hjalmarsson, L. & Suominen, M. (1993). Banking Efficiency in the Nordic Countries. *Journal of Banking and Finance*, 17, 371-388.

- Chang, M. (2014). An Explanation for the Paradox Phenomenon in Taiwan's Bank Performances. *International Journal of Financial Research*, 5(1), 21-28.
- Chen, C. (2009). *Bank Efficiency in sub-Sahara African Middle-Income*. IMF Working Paper.
- Chortareas, G.E., Girardone, C. & Ventouri, A. (2013). Financial Freedom and Bank Efficiency: Evidence from the European Union. *Journal of Banking and Finance*, 37, 1223-1231.
- Cook, W.D., Tone, K. & Zhu, J. (2014). Data Envelopment Analysis: Prior to choosing a Model. *Omega*, 44, 1-4.
- Cooper, W.W., Seiford, L.M. & Tone, T. (2007). *A Comprehensive Test with Models, Applications, References and DEA-Solver Software*. NY: Springer Science + Business Media Inc.
- Delis, M.D. & Papanikolaou, N.I. (2009). Determinants of Bank Efficiency: Evidence from a semi-parametric Methodology. *MPRA*, 1-26.
- Delis, M.D., Koutsomanoli-Filippaki, A., Staikouras, C. & Gerogiannaki, K. (2008). Evaluating Cost and Profit Efficiency: A Comparison of Parametric and Non-parametric Methodologies. *MPRA*.
- Drake, L., Hall, M.J.B. & Simper, R. (2006). The Impact of Macroeconomic and Regulatory Factors on Bank Efficiency: A Non-parametric Analysis of Hong Kong's Banking System. *Journal of Banking and Finance*, 30, 1443-1466.
- Ebhodaghe, J. (1997). Distress Management and Prevention Strategies for the Nigerian Banking System. *NDIC Quarterly*, 6, 19-36.
- Elumilade, D. (2010). Mergers and Acquisitions and Efficiency of Financial Intermediation in Nigeria Banks: An Empirical Analysis. *International Journal of Business and Management*, 5(5), 201-209.
- Fadare, S. (2011). Banking Crisis and Financial Stability in Nigeria. *International Research Journal of Finance and Economics*, 63, 1-12.
- Fadzlan, S. & Muzafar, S.H. (2012). Developments in the Efficiency of the Malaysian Banking Sector: The Impacts of Financial Disruptions and Exchange Rate Regimes. *Progress in Development Studies*, 12(1), 19-46.
- Fukuyama, H. & Weber, W.L. (2010). A Slacks-based Inefficiency Measures for a Two-stage System with Bad Outputs. *Omega*, 38, 398-409.

- Gulati, R. (2011). Evaluation of Technical, Pure Technical and Scale Efficiencies of Indian Banks: An Analysis from Cross-sectional Perspective. *13th Annual Conference on Money and Finance in the Indian Economy* (pp. 1-28). Mumbai: Indira Gandhi Institute of Development Research.
- Hecko, H. (2007). *Financial Intermediation in the Pre-consolidated Banking Sector in Nigeria*. World Bank.
- Jayaraman, A.R. & Srinivasan, M.R. (2014). Analysing Profit Efficiency of Banks in India with Undesirable Output: Nerlovian Profit Indicator Approach. *IIMB Management Review*, 26, 222-233.
- Jemric, I. & Vujcic, B. (2002). *Efficiency of Banks in Croatia: A DEA Approach*. Croatian National Bank Working Paper.
- Kama, U. (2006). Recent Reforms in the Nigerian Banking Industry: Issues and Challenges. *CBN Bullion*, 30(3), 12-20.
- Kama, U. (2009). Banking Sector Crisis and Resolution Options in Nigeria. *CBN Bullion*, 33(4), 7-18.
- Khalad, M.S.A., Badrul, H.K. & Mazila, M.D.Y. (2014). Efficiency and Determinants in Libyan Banking. *International Journal of Business and Social Science*, 5(5), 156-168.
- Kumar, S. & Gulati, R. (2008). An Examination of Technical, Pure Technical, and Scale Efficiencies in India Public Sectors Banks using Data Envelopment Analysis. *Eurasian Journal of Business and Economics*, 1(2), 33-69.
- Liu, F.F. & Chen, C. (2009). The Worst-Practice DEA Model with Slack-based Measurement. *Computers and Industrial Engineering*, 57, 496-505.
- Mainoma, M. (2010). Towards I-Theory of Bank Failure in Nigeria. *Nasarawa State University Faculty of Administration Conference Proceedings*, 2(9-11) (pp. 20-27). Keffi: Nasarawa State University.
- Mester, L. (1997). Measuring Efficiency of U.S Banks: Accounting for Heterogeneity is important. *European Journal of Operational Research*, 98, 230-242.
- Mohammed, S. (2002). *Finance-growth Nexus in Sudan: Empirical Assessment based on an Application of the Autoregressive Distributed Lag (ARDL) Model*. Kuwait: Arab Planning Institute.
- Mohanty, S.K., Lin, W.T. & Lin, H. (2014). Measuring Cost Efficiency in Presence of Heteroskedasticity: The Case of the Banking Industry in

Taiwan . *Journal of International Financial Markets, Institutions and Money*, 26, 77-90.

- Muhammad, A.H. & Muhammad, M.M. (2013). Two-stage Analysis of Banking Efficiency in Nigeria. *Proceedings of the 11th International Conference of DEA*, (pp. 395-401). Samsun, Turkey.
- Nworji, I.D., Adebayo, O. & David, A.O. (2011). Corporate Governance and Bank Failure in Nigeria: Issue, Challenges and Opportunities. *Research Journal of Finance and Accounting*, 2(2).
- Obafemi, F. (2012). The Technical Efficiency of Nigerian Banks. *Asian Economic and Social Society*, 2(2), 407-420.
- Ogunleye, G. (2002). The Causes of Bank Failure and Persistent Distress in the Banking Industry. *NDIC Quarterly*, 2(2), 19-38.
- Oke, D.M. & Poloamina, I.D. (2012). Further Analysis of Bank Efficiency Correlates: The Nigerian Experience. *Journal of Applied Finance and Banking*, 2(4), 1-11.
- Olaosebikan, B. (2009). *Surveying Efficiencies of Nigerian Banks before and after the Minimum Capital Requirement Increase*. Illinois Wesleyan University: Honors Project.
- Osaze, E. (2011). *The Specificities of Value Melt-down in the Nigerian Stock Exchange 2008-2010: Some Parallax Snaps*. Benin: University of Benin.
- Oteh, A. (2010). *The Global Financial Crisis and Financial Reforms in Nigeria: A Capital Market Perspective*. United State House of Representative Committee on the Global Financial Crisis.
- Owolabi, A. & Ajayi, N.O. (2013). Financial Efficiency of Banks in the Pre-and-Post Mergers and Acquisitions Era of Banks in Nigeria: A Comparative Analysis. *Global Business and Economics Research Journal*, 2(7) , 12-27.
- Premachandra, I.M., Chen, Y. & Watson, J. (2011). DEA as a Tool for Predicting Corporate Failure and Success: A Case of Bankruptcy Assessment. *Omega*, 39, 620-626.
- Ray, S. (2007). Are Some Indian Banks too Large? An Examination of Size Efficiency in Indian Banking. *Journal of Productivity Analysis*, 27(1), 41-56.
- Sanusi, J. (2002). Central Bank and the Macroeconomic Environment in Nigeria. *CBN Quarterly*, 3(3).

- Sanusi, L. (2010). *Global Financial Meltdown and the Reforms in the Nigerian Banking Sector*. Bauchi: Abubakar Tafawa Balewa University.
- Sanusi, L. (2011). *Banks in Nigeria and National Economic Development: A Critical Review*. Abuja: Canadian High Commission in Joint Collaboration with the Chartered Institute of Bankers of Nigeria and the Royal Bank of Canada.
- Soludo, C. (2009). *Global Financial and Economic Crisis: How Vulnerable is Nigeria?* Abuja: House of Representative Committee on Banking and Currency.
- Stavarek, D. & Repkova, I. (2012). Efficiency in the Czech Banking Industry: A Non-parametric Approach. *Acta University Agriculturae Et Silviculturae Mendelianae Brunensis, LX(2)*, 357-366.
- Tanko, M. (2008). A DEA Analysis of Bank Performance in Nigeria. *MPRA*, 1-17.
- Tsolas, I.E. & Charles, V. (2015). Incorporating Risk into Bank Efficiency: A Satisfying DEA Approach to Assess the Greek Banking Crisis. *Experts Systems with Applications, 42*, 3491-3500.
- Umoh, N. (2004). Capital Restructuring of Banks: A Conceptual Framework. *Central Bank of Nigeria Fourth Annual Monetary Policy Conference*. Abuja: Central Bank of Nigeria.
- Umoren, A.O. & Olokoyo, F.O. (2007). Merger and Acquisition in Nigeria: Analysis of Performance Pre and Post Consolidation. *Lagos Journal of Banking, Finance and Economic Issues, 1(1)*.
- Usman, O.A. & Fadipe, M. (2014). An Empirical Analysis of Allocative Efficiency of Nigerian Commercial Banks: A DEA Approach. *International Journal of Economics and Financial Issues, 4(3)*, 465-475.
- Valverde, S.C., Humphrey, D.B. & Fernandez, F.R. (2003). Bank Deregulation is better than Mergers. *Journal of International Financial Markets, Institutions and Money, 13(5)*, 429-449.
- Wang, K., Huang, W., Wu, J. & Liu, Y. (2014). Efficiency Measures of the Chinese Commercial Banking System using an Additive Two-stage DEA. *Omega 44*, 5-20.
- Yen, Q. (1996). The Application of Data Envelopment Analysis in conjunction with Financial Ratios for Bank Performance Evaluation. *Journal of the Operational Research Society, 47*, 980-988.

Yu, Y., Barros, A., Tsai, C. & Liao, K. (2014). A Comparison of Ratios and Data Envelopment Analysis: Efficiency Assessment of Taiwan Public Listed Companies. *International Journal of Academic Research in Accounting, Finance and Management Sciences*, 4(1), 212-219.

**EXTENT OF COMPLIANCE WITH ISLAMIC FINANCIAL
ACCOUNTING STANDARDS BY JAIZ BANK, NIGERIA –
Lawal, R. & Dandago, K. I.**

Research Assistant,
International Institute of Islamic Banking and Finance,
Bayero University, Kano, Nigeria
rashlawal@yahoo.com, +2348036596226
(Corresponding Author)

And

Professor of Accounting, Department of accounting,
Faculty of Social and Management Sciences,
Bayero University, Kano, Nigeria
kidandago@gmail.com, +2348023360386

Being the revised full paper submitted for publication in the ICAN Journal
of Accounting and Finance (IJAF) of the Institute of Chartered
Accountants of Nigeria (ICAN),
July, 2015

**EXTENT OF COMPLIANCE WITH ISLAMIC FINANCIAL ACCOUNTING
STANDARDS BY JAIZ BANK NIGERIA**

Abstract

Compliance with conventional accounting system by Islamic banks in corporate financial reporting is very common in many jurisdictions despite the unique features of Islamic banks and the differences that exist between conventional banks and Islamic banks in terms of their services, operations and modus operandi in countries where Islamic banking is well established. This study intends to assess the extent of compliance with corporate financial reporting by Islamic banks in Nigeria with a view to

finding out the extent of compliance for a better understanding of the reporting practices by the Islamic banks with respect to Islamic Financial Accounting Standards (FASs). The research uses descriptive statistics to explain important characteristics of both the dependent and the independent variables of the study. To quantify the level of compliance with FASs, Compliance Index containing eleven (11) requirements of FAS was devised and applied to financial statements of Jaiz Bank plc (Islamic bank) studied over three year period. The study establishes that compliance with FAS by Jaiz Bank, Nigeria is low with a compliance level of 21.87%., which suggests that the bank is complying more with the provisions of conventional accounting standards (like IFRS) than with the Islamic Financial Accounting Standards (FASs). Therefore, this paper recommends that Financial Reporting Council of Nigeria (FRCN) should adopt the FAS for the use of Islamic banks in order to intensify their monitoring and enforcement activities to ensure that all banks are accounting standards compliant. Similarly, management of Islamic banks should ensure compliance with all the relevant AAOIFI standards in their operations with a view to enhancing the credibility and reliability of their information disclosures.

Keywords: Financial Reporting, AAOIFI, Islamic Bank, Jaiz Bank, FAS

1.0 Introduction

Corporate financial reporting can be seen as the process of preparing and reporting financial information to users of such

information in various forms which consists of financial statements and accompanying notes that communicates information about a company's financial health to its various stakeholders. Stewardship is an important anchor on which corporate financial reporting is based, especially due to the separation of ownership from management in company corporate governance which started with the wake of industrial revolution in the 18th century in Europe. This separation of owners from managers creates opportunities for opportunistic management behaviour (Willet, 1968; and Imhoff, 2003) and during this period there was no meaningful reporting system. Therefore to improve on the economic condition, the securities Act of 1933 and the Securities Exchange Act of 1934 were passed, and the SEC was saddled with the responsibility of establishing financial reporting standards to guide the reporting practice with the aim of providing a sound, stable and healthy financial system (Chapra, 2000).

It is pertinent to note that, the socio political and economic environment of a country would to a large extent affect the nature, development and quality of financial reports and reporting practice in the country. In this regard, "all countries have found it necessary to use coercive legal power to compel companies to disclose adequate financial information to shareholders and other users" (Glautier and Underdown, 1997) thus making Corporate Financial Reporting (CFR) an essential activity in the modern day management. Therefore, the main aim of the financial statement is to provide information and permit understanding of the financial aspects of the firm. Corporate financial reports are aimed at providing information that is reliable, comparable, relevant, adequate, as well as, comprehensible and understandable to the users for the purpose of taking informed judgments and decisions.

The banking industry is widely recognized as an indispensable link in the process of economic development due to its role in financial intermediation by mobilizing funds from the surplus units and channelling same to the deficit units of the economy for productive activities. CFR is, therefore, essential for banks with a view to enabling the users to understand their financial positions in terms of profitability, liquidity, gearing, productivity, investment and overall performance for the purposes of taking informed judgments and decisions.

The CBN new banking model authorized the establishment of specialized banks. Islamic bank however fall under the category and is currently operated at a regional level. The Islamic banks serves

the same purpose of providing financial services as their conventional financial counterparts except that they operate in accordance with principles and rules of Islamic commercial jurisprudence that generally recognizes profit and loss sharing and the prohibition of interest. According to Dogarawa (2012), an Islamic bank is a financial intermediary and trustee of other people's money like any conventional bank with the possible difference that the payoff to all its depositors is a share in profit and loss in one form or the other and its operations are conducted based on the principles of Islamic *Shari'ah*. Other non-permissible transactions include those involving uncertainty or ambiguity relating to the subject matter, terms or conditions; gambling; speculation; unjust enrichment; exploitation/unfair trade practices; dealings in pork, alcohol, arms & ammunition, pornography and other transactions, products, goods or services which are not compliant with the rules and principles of Islamic commercial jurisprudence.

A review of the literature shows that there are a number of differences between conventional banks and Islamic banks in terms of their services, operations and modus operandi in countries where Islamic banking is well established. The current standards, which are based on conventional frameworks, seem insufficient to guide the Islamic financial institutions. Instead, they follow a corresponding set of Islamic Accounting standards, which are set by the Accounting and Auditing Organization for Islamic Financial Institutions (AAOIFI) based in Bahrain. The AAOIFI standards in many cases have conflict with IFRS which is in used globally by many banks and other financial institutions.

However, compliance with conventional accounting standards (IASs, IFRSs and local standards) by Islamic banks in corporate financial reporting is still very common in many jurisdictions, although in some countries Islamic banks are in addition expected to comply with Financial Accounting Standards (FAS) issued by AAOIFI. For example, In Bahrain, the authorities require compliance with both AAOIFI standards and IFRS as requested by Central Bank of Bahrain (CBB). Similarly, in Nigeria, the Central Bank of Nigeria requires compliance by Islamic bank with AAOIFI, IFRS and SAS (where IFRS is not applicable).

Sequel to the above, this study intends to find out the extent to which Islamic bank (Jaiz Bank) in Nigeria comply with the AAOIFI accounting standards for a better understanding of the reporting practices by the bank.

The study intends to contribute to the general body of knowledge by filling the void in the academic literature with respect to the extent

to which Jaiz bank comply with the standard. Management of Jaiz bank in Nigeria stand to benefit from the findings of the research in that the study would prompt them on issues dealing with disclosure of accounting information and method of presentation as required by statutory and professional pronouncements in Nigeria. It is also hoped that the study will be important to government and its agencies particularly those established to regulate and oversee Islamic banking in Nigeria as it would help them to know the extent of compliance with statutory and professional requirements of CFR by full pledged Islamic bank in the country.

2.0 Literature Review

2.1 The concept of Islamic corporate financial reporting

Corporate reporting from Islamic context explains that all resources are trust from God and accountability on how these resources are managed is mandatory. God requires Muslims to document their transactions.

"O ye who believe! When ye deal with each other, in transactions involving future obligations in a fixed period of time, reduce them to writing; let a scribe write down faithfully as between the parties..." (Qur'an, sura al-baqarah 2: 282).

Baydoun and Willett (2000); argue that given the emphasis on responsibility and accountability in Islam, an information system that is relevant to a society would be one that satisfies the principles of full disclosure and social accountability.

The Qur'an chapter 4 verse 58 provides thus "Allah doth command you to render back your trusts to those to whom they are due and when ye judge between people that ye judge with justice..."

Hence, Corporate Financial Reporting is a process through which appropriate information is communicated to users which enable them to assess whether the entity is operating within the bounds of Shariah (Islamic Principles) and fulfilling its responsibilities to society and the environment, and for the users to make decisions that would persuade the entity to fulfil or to continue to fulfil those responsibilities (Malaysian Accounting Standards Board (2009)).

Therefore, financial reporting is the means through which the managers of an entity can discharge their trust to all relevant stakeholders.

2.2 Usefulness of Islamic Financial Reporting

The main objective of standardization is to protect the interests of the shareholders and other stakeholders. The level profitability and extent, to which business assets are secured, therefore become important items of concern to all stakeholders Kasum (2011). In the same vein, Baydoun and Willet (2000); tested a hypothesis on the usefulness of financial report and found that they are the same irrespective of religious or cultural groups. He suggested that the current balance sheet and the value added statement would meet Islam's objective of socioeconomic justice and accountability. Baydoun and Willet's model of Islamic corporate financial reports was initially tested through a questionnaire survey by Sulaiman (1998); who found that there were no differences in the perceptions of usefulness of corporate reports between Muslim and non-Muslim respondents. Another study by Sulaiman (2001); revealed that Muslims and non-Muslims were no different as far as accounting matters were concerned. Further, the Accounting Principles Board's Statement No. 4 (1970) also endorsed the decision-usefulness view of the financial statements as the basic purpose of corporate reporting is to provide quantitative financial information about a business enterprise that is useful to statement users, particularly owners and creditors, in making economic decisions. "The Trueblood Report (AICPA, 1973) also supported the decision usefulness approach because accounting is not an end in itself. As an information system, the justification of accounting can be found only in how well accounting information serves those who use it. Thus, the various studies agree that the basic objective of corporate is to provide information useful for making economic decisions.

From the above studies it can be concluded that the present mode of financial reporting is universal from the viewpoint of preparing to a greater degree and of usefulness to a substantial level irrespective of region and religion and the annual report is the only medium through which significant amount of information is disseminated to various user groups. However this should not be so because of the unique features of the Islamic banks which are not captured in the conventional reporting practice.

2.3 Disclosure of Islamic Accounting Information

In appraising existing reporting systems or efforts to construct a new one must begin by specifying the role and purpose of disclosure in Islam. This can be done by reference to the *Quran*. The existence of accounting can be justified by the *Quranic* instruction to Muslims to record in writing some transactions that they are party to (*Quran 2*, verse 282). Baydoun and Willett (1997a, 1997b); develop two principles they consider

central to the preparation of Islamic corporate reports. Ownership in Islam is viewed as the holding of resources in trust for God (*Quran* 6, verse 165 and *qura'an* 57 verse 7) and owners are thus expected to use those resources in accordance with God's wishes. Practically, this means use according to the *Shariah*. Baydoun and Willett (1997a); view this as an obligation that a business would owe the *Ummah*. This is termed social accountability and it is argued that the documenting of its discharge should be one of the central tasks of Islamic accounting. This information should then be made freely available under a concept of full-disclosure. The latter principle is poorly defined and at times, it seems to be a call for complete disclosure of all the data collected on every transaction of a business. While this might be an ideal, pragmatically it has to be tempered by some notion of relevance and materiality. Disclosure in Islamic way also entails supplementing existing statements with a current-value balance sheet and a value added statement. The major basis for the inclusion of both a historical and current-value balance sheet is full (or more comprehensive) disclosure. Interestingly, social accountability is also cited as support for this and for the value added statement. These proposals appear to be premised on a literal definition of social accountability. In Islam, activities are socially desirable if permitted by the *Shariah*, which expresses the basic norms of an Islamic society. Thus, social accountability should be a concern about compliance with the *Shariah*. Neither a value added statement nor a current-value balance sheet assists this cause.

2.4 Financial Reporting by Islamic Banks in Nigeria and Disclosure Requirements

Nigeria has regulatory and professional framework that govern the conduct, ethics and operation of companies. These include the Companies and Allied Matters Act (CAMA 20 LFN 2004), Banks and Other Financial Institutions Act (BOFIA Cap B3 LFN 2004), Statements of Accounting Standards (SAS), International Financial Reporting Standards (IFRS) and Statement of Financial Accounting issued by Accounting and Auditing Organization for Islamic financial institutions (AAOIFI).

The Accounting and Auditing Organization for Islamic Financial Institutions (AAOIFI)

The Accounting and Auditing Organization for Islamic Financial Institutions (AAOIFI) began as the Financial Accounting Organization for Islamic Banks and Financial Institutions in Bahrain in March 1991. It was the initiative of the Islamic Development Bank, which along with five other Islamic banking groups was the founder member of the AAOIFI. The main objective of the AAOIFI is to 'prepare, promulgate and interpret accounting and auditing standards for Islamic financial institutions' and so included in its

structure is an Accounting and Auditing Standards Board (AASB). Statements and standards issued by the AASB are an attempt at self-regulation by the Islamic banks. It has issued 68 standards: 25 accounting standards; 5 auditing standards; 6 governance standards (incl. on Shari'a supervision); 2 codes of ethics; and 30 Shari'a standards (rules for application of Shari'a). It is also developing new standards and reviewing existing standards. They are supported by over 165 institutional members from over 35 countries.

Members include central banks and regulatory authorities; Islamic and conventional financial institutions; accounting and auditing professions; and Islamic financial support services providers. In order to support technical application of standards, AAOIFI offers the following professional qualification programs: Certified Islamic Professional Accountants (CIPA), and Certified Shari'a Adviser and Auditor (CSAA).

2.5 Review of Empirical Studies on Islamic Corporate Financial Reporting

Vinnicombe (2010); argued the extent to which Islamic financial institutions comply with the accounting and governance standards issued by the AAOIFI in their financial reporting. Because Islamic banks operate under vastly different regulatory regimes and political and economic conditions across the globe, the sampled banks were selected from the kingdom of Bahrain. The compliance for the purpose of this study can be defined as the degree to which Islamic financial institutions comply with the multitude of issues in the financial accounting standards (FASs) issued by the AAOIFI. However, the findings of the study indicate high level of compliance with respect to the governance standards relating to the in-house supervisory boards of Islamic banks and reporting the Islamic Murabahah contract. In contrast, compliance with the AAOIFIs requirements regarding the zakah, otherwise called the religious tax, and the Mudarabah contract is relatively low. In addition, a higher number of compliance items are associated with retail as opposed to wholesale banks. However, it should be noted that the samples of the retail bank are more homogeneous and consistent over time compared to those of the wholesale banks.

El-Halaby (2013); investigate For What Extent the Disclosure's Islamic Banks in Annual Report Complies and Adherences with IFRS and AAOIFI using the annual reports for 20 Islamic banks (IB) in 11 different countries and covering period from 2008 to 2012. The paper uses 2 Disclosure Index (One for IB that apply IFRS and another for IB that apply AAOIFI), Disclosure Model for Hudaib and Content Analysis to test the disclosure level. It was concluded that the level of disclosure for

Islamic banks by adopting IFRS is higher than disclosure by adopting AAOIFI but it is not better or sufficient for Islamic Banks because by adopting IFRS, Islamic banks ignores numerous items related to the nature of Islamic banking as Zakat and Qard Hassan (not included by IFRS). It has impacts on the image of the Islamic bank and impressions for stakeholders who deal with the Islamic banks as a different bank against conventional bank. The paper also conclude that, the Islamic banks that apply IFRS is a full adopting because it is a mandatory but the Islamic banks that apply AAOIFI is a partial adopting because it is voluntary. So, the difference in the level of disclosure between IFRS and AAOIFI is not because the IFRS is better than AAOIFI but because the percentage of adopting of these standards.

Ullah, (2013); examines the level of Compliance of AAOIFI guidelines regarding General Presentation and Disclosure in the Financial Statements of Islamic Banks listed in Bangladesh Compliance with AAOIFI. The study found that these banks comply on an average 44.68 percent (90.71 items of 203) of AAOIFI Guidelines regarding General Presentation and Disclosure in the Financial Statements. Standard deviation of total compliance score is 3.14 indicate that there is very poor difference among the Islamic banks in this regard.

Sarea and, Hanefah, (2013); determine the need of Islamic Accounting Standards a review of the literature for Islamic financial institutions (IB). the paper found that one of the major challenges facing IB lies in the preparation of the financial statements under different accounting standards and which may lead to problems of comparability, reliability and compliance level measurement The paper concludes with various recommendations for future research, the most important of which is the need for future studies on how AAOIFI accounting standards can be made mandatory in all Muslim countries.

3.0 Methodology

The research design used for this study is the ex post factor research design. This design is used where the phenomenon under study has already taken place Abdullahi (2008). The data will be obtained from the annual reports and accounts of the sampled banks which are historical in nature, thereby rendering this research an ex post factor.

This study covers the only Islamic banks in Nigeria as at 31st December 2014 and the research was conducted using secondary sources of data. The data used for the analysis of the research was obtained from the

annual reports and accounts of the sampled bank. The data sourced from the annual reports and accounts of the bank were particularly in relation to accounting information disclosure as required by FASs (Financial Accounting Standard).

To determine the extent of compliance, the requirements of FAS was used to construct a Compliance Index, the total of which gives the Dependent Variable of the study. Compliance Index is, according to Al-Shammari (2005); a very reliable measurement device for compliance with accounting standards. Consequently, studies on compliance such as, Kantudu (2006); and Mamman (2006); have adopted compliance index to determine extent of compliance with accounting standards. The frequent use of this technique justifies its effectiveness and hence considered appropriate for this research. This is because, an important measure of the usefulness of a research tool is the frequency with which it is being used (Marston and Shrivs, 1991); and researchers will cease to use a research tool if it produces poor result.

Based on the checklist compliance with the requirement of FASs (the dependent variable) is a function of 11 requirements, represented by $v_1, v_2... v_{11}$. Consistent with Barde (2010); a maximum score of 10 points was assigned to denote total compliance to a variable, while 0 denotes non compliance. Where a variable has more than one requirement, it was dissected into sub-variables and the 10 points apportioned among the sub-variables. This became necessary to ensure accuracy and fairness in the grading. Therefore, Islamic bank is a function of 11 FASs requirements.

$$FASs = F (V1, V2.....V28)$$

To determine the degree of compliance with the requirements of FASs by the Islamic banks (i.e. the dependent variable) the aggregate score per requirements (v_1 to v_{17}) was taken and weighted against the expected degree of application, then the result was expressed on a scale of 100 to enhance its comprehensibility. Thus, the following compliance formula, consistent with Kantudu (2006); Mamman (2006) and Barde (2010); but with slight modification was used to achieve this objective:

$$Dc = \sum_i^n \frac{Ara}{Mra} \times 100$$

Where:

Dc = Degree of compliance

E = Summation or addition

n = Number of expected variables to be complied

Ara = Actual number of variables complied by sampled bank

Mra = Maximum number of variables (standards) expected to be complied with by the sampled banks.

3.2 Grading and Scoring of Compliance with FAS

Since the result is expressed as a percentage, the following criteria consistent with Kantudu (2006); Mamman (2006) and Barde (2010); was used to interpret the results. Table 3.4 shows the criteria used in grading level of compliance with IFRS 7 and FASs.

Table 3.3: Criteria for Grading Compliance with FASs by the Sampled Bank

S/No	Percentage Sore	Point s	General Remarks
1.	70-100%	7-10	Strongly Applied
2.	50 -69%	5-6.9	Semi Strongly Applied
3.	40 – 49%	4-4.9	Weakly Applied
4.	20-39%	2-3.9	Very Weakly Applied
5.	0-19%	0-1.9	Non Application

Source: Grading application of standards modified from Kantudu, (2006), Mamman (2006) and Barde (2010)

Table 3.2 shows the criteria used in grading compliance with the provisions of FASs. A score of 7 -10 indicates strong application, 2 - 6.9 weak compliance while 0 -1.9 indicates non-application.

4.0 Results and Discussion

4.1 Compliance Index

Compliance Index presents the extent of compliance with the provisions of FASs by Jaiz bank. To achieve this, annual accounts of the bank were scrutinized to identify the level of compliance with 11 requirements of FASs by the banks

Table 4.1: Summary of Compliance by Islamic Bank

S/N	Bank	FAS Compliance		
		Total Score	Expected Application	Total Application %
1	Jaiz Bank	240.58509	1100	21.87
		240.58509	1100	21.87

Source: Computed from the Annual Reports of the bank

The compliance Index shown in Table 4.1 present 3 years summary of the level of compliance with each of the disclosure requirements of FASs. The compliance index of the bank and percentage of compliance per variable are presented horizontally as rows. Detailed application index for the individual requirements of the sampled banks is shown in Tables 1 to 28 of the Appendix. Similarly, the appendices contain the analysis of the level of compliance with FASs by the bank. A close look at the banks total compliance revealed that in line with our grading, a very weak level of disclosure is adhered to as it has 28.87% compliance levels.

4.2 To what extent are the provisions of accounting standards complied with by Islamic bank in Nigeria?

This section discusses disclosure of accounting information in the annual reports and accounts of the Jaiz bank with respect to provisions of FASs. The section establishes the extent of compliance with the provisions of FASs. However, a careful examination of the result suggests that the main regulating standard complied with by the Islamic bank is the provisions of conventional accounting standards (like IFRS). Based on the above, it is

obvious that Islamic bank fail to apply the requirements of FAS. The research upholds that accounting information disclosure by Jaiz bank in Nigeria with respect to FAS is low.

5.0 Conclusions and Recommendations

Based on the results and revelations of this study, it can be concluded that FAS is yet to be adopted by the FRCN but yet complied with by Jaiz bank in their annual reports and accounts though the Islamic bank does not comply fully with FASs because of absence of some products and transactions. Hence, the overall compliance by Jaiz Bank to the requirements of FASs is weak. Therefore, it is recommended that FRCN and CBN should intensify their monitoring and enforcement activities to ensure higher level of compliance with FAS in particular and the remaining Accounting Standards in general. Managements of Islamic banks should ensure compliance with all the relevant AAOIFI standards in their operations with a view to enhancing the credibility and reliability of their information disclosure.

REFERENCES

AAOIFI, (2010). *Financial accounting standards*. Accounting and Auditing Organization for Islamic Financial Institutions (AAOIFI). Manama, Bahrain.

Abdullahi, H.Z. (2008). "Determinants of Compliance with Accounting Standard on Depreciation (SAS 9) by Listed Banks in Nigeria", Unpublished M. Sc Thesis Submitted to the Department of Accounting, Bayero University, Kano.

Barde I.M, (2010). An evaluation of accounting information disclosure in the Nigerian oil marketing industry. *A Thesis presented to Department of Accounting, Bayero University Kano, for the award of Doctor of Philosophy, Accounting.*

Baydoun, N and Willett, R (1997a). "Islam and Accounting: Ethical Issues in the Presentation of Financial Information", *Accounting Commerce and Finance: The Islamic Perspective*, 1(1), 1-25.

Baydoun, N and Willett, R (1997b). "Islamic Corporate Reports", *Accounting Commerce and Finance: The Islamic Perspective Conference Proceedings*, Sydney, University of Western Sydney.

Baydoun N, Willet R (2000). Islamic Corporate Reports. *Abacus*. 36: 71-90.

Chapra, M. (1985). "Towards a just monetary system", The Islamic Foundation, Leicester, characteristics of the firm". *Journal of Accounting and Public Policy*, 3, 97-118

El-Halaby, S.I. (2013). For What Extent the Disclosure's Islamic Banks in Annual Report Complies and Adherences with IFRS and AAOIFI. School of Business, Plymouth University

FASB, (1979). *Objectives of Financial Reporting by Business Enterprises*, Statement of Financial Accounting Concept No. 1. Para 24.

Glautier, M.W.E. and Underdown, B. (1997). *Accounting Theory and practice*. Pitman, London.

Imhoff, E. (1992). "The relationship between perceived accounting quality and economic. *Journal of accounting and public policy*. 11(4), 97-118.

Kantudu, A. S. (2006): An analysis of the impact of pension reform Act in Nigeria. *PhD Thesis. Department of Accounting, Ahmadu Bello University Zaria, Nigeria*.

Kasum, A. S. (2011). The Impact of Compliance with Accounting Standards on Assets and Profitability of Nigerian Quoted Companies. *The Journal of Commerce*, 3(3), 2220-6043.

Mamman, S. (2006): Accounting for leasing in Nigeria. *PhD Thesis. Department of Accounting, Ahmadu Bello University Zaria, Nigeria*.

Sulaiman, M. (1998). "The Usefulness of Current Value Balance Sheet and the Value Added Statement to Muslims: Some Evidence from Malaysia". *Accounting, Commerce & Finance: The Islamic Perspective*, 2(2): 24-66.

Sulaiman, M. (2001). "Testing a model of Islamic Corporate Financial Reports: some experimental evidence". *IIUM Journal of Economics and Management*, 9 (2): 115-39.

Trueblood Report, (1973). Objectives of Financial Reporting. Statement of financial Accounting Concepts No1.

Ullah, M. H. (2013), The level of Compliance of AAOIFI guidelines regarding General Presentation and Disclosure in the Financial Statements of Islamic Banks listed in Bangladesh Compliance with AAOIFI. *Global Journal of Management and Business Research*, 5(28).

Vmnicombe, T. (2010). AAOIFI reporting standards: Measuring compliance Advances in Accounting, incorporating Advances in International Accounting, 26(1), 55-65.

Willet, E. R. (1968). Fundamentals of securities Markets. Newyork, NY: Appleton Centaury crofts.

ALTMAN'S Z-SCORE DISCRIMINANT ANALYSIS AND BANKRUPTCY ASSESSMENT OF BANKS IN NIGERIA – Nwidobie, B. M.

DEPARTMENT OF ACCOUNTING & FINANCE

CALEB UNIVERSITY, LAGOS

TEL. NO: 08035806760 & 01-7655909

Email: Barikem@yahoo.com

Abstract

This study aims to determine the distress level subsisting in the bridge banks set up by the Central Bank of Nigeria in 2011 to take over the nationalized banks; and the 2011-classified unsound banks using the Altman's discriminant analysis model. An Altman z-score discriminant analysis of financial reports of two of the nationalized banks (exclusive of Enterprise Bank Ltd already acquired by Heritage bank Plc) for two years preceding their nationalization and two years after; and two of the Central Bank of Nigeria 2011-classified unsound banks: Wema Bank Plc and Union Bank Plc sampled using the stratified sampling technique shows that there are marginal improvements in the financial status of the sampled banks between 2010-2013 but they are still in a bankrupt position with Union Bank Plc, Wema Bank Plc, Keystone Bank Ltd and Mainstreet Bank Ltd having a Z-score of -0.56, 0.417, 1.5 and 0.45 respectively at 2013, all below the minimum threshold of 2.675 for classification of a bank as sound and non-bankrupt. This implies that the general broad-based monetary policy measures introduced by the CBN for the financially distressed bank are not much effective in resolving their financial crises in general, making necessary the introduction of bank-specific monetary and financial policies to solve identified bank-specific problems, and the CBN directly supervising these banks with daily monitoring of their operations.

Key words: Bankruptcy, discriminant analysis, failed banks, financial crises, Z-score

1.0 Introduction

Prediction of corporate failures is rife in foreign literature, but non-existent in Nigeria except that by the Central Bank of Nigeria carried out in the course of performing its statutory functions. To Yildiz and Akkoc (2009), repeated global financial crises have increased corporate bankruptcies necessitating its prediction. Erdogan (2008) noted that moves by a country at the liberalizing its financial market (as witnessed during the recent bank consolidation exercise in Nigeria) opens such economies, increasing its fragility; making it vulnerable to further global economic crises. Yildiz and Akkoc (2009) contended that monitoring and controlling of the banking sector in any economy is important for maintaining confidence in such a financial system. This to them, necessitates its tight regulation to make it healthy. To Lanine and Vennet (2006), the healthier a country's banking system, the greater will be investors' confidence; with attendant increases in private savings and allocation of credit facilities to relevant productive sectors with positive effects on economic growth. Occurrence of bank bankruptcies is seen to have greater effect on the economy than bankruptcies in other sectors. Yildiz and Akkoc (2009) observed that its effect exceeds bank stakeholders extending to the entire economy.

Varied reasons had been adduced for corporate bankruptcies. Sullivan et al (1998), Argentin(1997), Blazy and Combiar (1997) and Lussier (1995) attributed corporate failures to accidental factors (malfeasance, death of leader, fraud, disasters, litigation), market factors (loss of market share, failure of customers, inadequate products), financial threats (undercapitalization, cost of capital, default on payment, loan refusal), macroeconomic factors of fragility (decline in demand, increased competition, high interest rate), information and managerial problems (incompetence, prices), costs and production structures, and strategy failures. The immediate and long-run effects of these are evident on corporate financial positions measurable using corporate liquidity status indicators: current and acid-test ratios; corporate financial risks measurable using the gearing ratios; and firm profitability measurable using operating profits to sales ratio. du Jardin (2009) noted that causes of corporate failures are predictable over time and preventable. To Perez (2002), these symptoms are observable from final accounts of such firms. Assets and credit evaluation measures were introduced by the Central Bank of Nigeria (CBN) to identify beforehand bankruptcy symptom in banks in Nigeria, in addition to frequent liquidity bailouts of these banks by the apex bank. The continuous negative liquidity positions and toxic nature of bank assets resulted in the takeover of three deposit money banks (AfriBank Nig Plc, Spring Bank Nig Plc, and BankPHB Plc) by the CBN in 2011 as they were financially distressed. Three bridge banks: Mainstreet Bank Ltd, Enterprise Bank Plc and Keystone Bank Ltd were set up to take

over their operations by the CBN. Three other financially unsound banks: Oceanic Bank Plc, FinBank Plc and Intercontinental Bank Plc were acquired by other banks within this period. Wema Bank Plc and Union Bank Plc were given bailouts by the CBN to resolve marginally their financial problems; with additional finances from rights issues. How financially sound are these bridge and unsound banks since the administrative and monetary intervention of the CBN in 2011?

1.2 Research objective

The objective of this study is to determine the financial distress level of the three bridge banks set up to take over the three nationalized banks in 2011 and three other non-nationalized banks classified as unsound by the CBN in 2011 using the Altman's discriminant analysis model.

1.3 Research hypothesis

The following hypothesis is tested in this study:

H₀: The 2011-unsound deposit banks are not yet financially sound.

H₁: The 2011-unsound deposit banks are financially sound.

2.0 Theoretical framework and review of literature

2.1 Theoretical framework

Globalization and cross border financial activities transfer financial crises across borders making national monetary control and administration difficult and cumbersome. Advanced theories and models offer monetary regulators means of assessing the liquidity and financial positions of deposit money banks within its control, and introduce corrective measures when distress symptoms are identified. Distress predictions seems a viable option for monetary regulators as identifiable-potential distress cases are corrected to avert bank financial crises with its contagion effect on other deposit money banks in the country and negative effects on the country's economy. Models (Altman's z-score discriminant analysis, neural-fuzzy model, factor analysis, logistic regression analysis, multivariate regression analysis and the artificial neural network) abound in bankruptcy literature for predicting corporate failures. These models has successfully predicted corporate failures firms within and across industries the world over with the Altman (1986) z-score analysis as the most successful (Arora and Saini, 2013; Martin et al, 2011; Jordan et al, 2010; Bellovary et al, 2007).

2.2 Literature review

The Altman Z-score model

In a bid to determine in advance the likelihood of corporate bankruptcies, Altman (1968) developed the Z-score discriminant model which uses a multivariate approach based on the values of both accounting and categorical variable measures. To him, as failed companies exhibit economic trends and proportions different from financially healthy firms, accounting and analysis of categorical measures' values need to be combined and weighted to produce another measure (standard credit risk). This he added, make better discrimination between failed and healthy firms. The model uses the multiple discriminant analysis to analyse variables to maximize the difference between group differences while maximizing differences within the group. To Kyriazopoulos et al (2012), this model uses a sequential process in which the processor includes or excludes variables using established statistical criteria with the optimal Z-score equivalent to:

$$ZETA_c = \{ \ln q_1 c_1 \} / q_2 c_2$$

where q_1 is prior bankruptcy and q_2 , non-bankrupt. C_1 and c_2 are costs of type 2 and 1 errors. Useable ratios for determining Z-score are:

- i. Short term debt/book value of equity (leverage)
- ii. Cash/total assets (liquidity)
- iii. Earnings before interest and taxes/total assets (profitability)
- iv. Retained earnings/total assets (cover)
- v. Earnings before interest and taxes/interest paid.

In Altman's (1983, 1993) revised model, five ratios were determined as jointly the best discriminators between business viability and failure. In the revised model, Altman (1983) required the use of: working capital/total assets (X1), retained earnings to total assets (X2), EBIT/total assets (X3), market value of equity/book value of total debt (X4) and sales /total assets ratio (X5); with Z as the overall index (Altman's score). He posited that the final discriminant function for public firms is:

$$Z = 0.012X1 + 0.014X2 + 0.033X3 + 0.006X4 + 0.999X5; \text{ and}$$

for private firms, a re-estimation of the model substituting the book value of equity for market value in X4, giving the revised Z-score model:

$$Z = 0.717X1 + 0.847X2 + 3.107X3 + 0.420X4 + 0.998X5$$

With $X4 =$ book value of equity/book value of total liabilities.

Firm overall Z-score of <2.675 indicates that is or that there is 95% chance of such a firm being bankrupt within twelve months. In practice, Altman (1968) argued that Z scores of $\geq 1.81 \leq 2.99$ indicate grey area;

values of < 1.81 shows that the firm is bankrupt, and Z-score of > 2.99 indicates that the firm is non-bankrupt. Arora and Saini (2013) and Martin et al (2011) argued that the empirical results of Altman's (1968) model and subsequent studies based on this model had widely, successfully and consistently predicted corporate failures, and has proved effective in predicting corporate bankruptcies across industries in various countries over different periods.

Altman Z-score model and corporate bankruptcy predictions

Bankruptcy indicators and predictions are rife in literature. Detailing indicators of corporate failures based on importance, du Jardin (2009) argued that financial variables (measured by financial ratios) obtainable from firm statement of financial positions and comprehensive incomes are best used. To him, these ratios express relationship between two variables either within a statement or between variables in both statements increasing the coverage of most corporate failure determining factors. In their study, Salmi and Martikainen (1994) used the financial data of different firms to control for size effect. Horrigan (1983) contended that non-controlling for size is itself positive on any study, as size itself may be a variable of interest in explaining some financial characteristics of firms. To du Jardin (2009), use of ratios makes interpretation accurate and comparable. Adding, Lev and Sunder (1979) noted that financial ratio data rely on the proportionality between the numerator and the denominator. Findings by Back et al (1994) showed that models built with financial ratios alone perform better than those built with common financial variables. This argument was substantiated by Pompe and Bilderbeek (2005), Perez (2002), Atiya (2001), Mossman et al (1998) and Keasey and Watson (1987). Relating bankruptcy to stock returns, Beaver (1968) found that equity returns predict bankruptcy earlier than financial ratios in general. Furthering, Clark and Weinsten (1983) and Altman and Brenner (1981) argued that stock market indicates bankruptcy at least a year before it occurs. To Aharony et al (1980), volatility in firm-specific return increases as bankruptcy converges.

From a monetary perspective, Hauser and Booth (2011) opined that accurate assessment of the probability of bankruptcy can lead to sound lending practice and better fair value of interest rates that reflect credit risks; adding that bankruptcy could be predicted in all sectors. The need for distress prediction in the financial sector is more pronounced as credit or counterparty risk assessment by rating agencies are reactive and not predictive. These predictions, to Hauser and Booth (2011) are feasible as bankrupt firms are outliers from the perspective of a group of healthy firms. Commenting on the spiral effects of bank bankruptcies, Vaziri et al

(2012) noted that assets' market will experience high level of volatility through huge movements in the exchange rates, interest rates and commodity prices; recommending that banks and other financial institutions need to add risk management to their investment decisions. In assessing bank financial distress, Betz et al (2013) suggested complimenting bank-specific vulnerabilities with indicators for country-level macro-financial imbalances and banking sector vulnerabilities.

On causes of bank bankruptcy in Europe, USA and Asia, Vaziri et al (2012) argued that changes in market, policy, economy and political influences were responsible factors, with these bankruptcies transcending national boundaries. The global crises, they added, resulted in mergers, acquisitions, takeovers, part nationalization and liquidation; attributing the crises in detail to sub-prime mortgages, collateralized debt obligations, frozen credit markets and credit swap defaults reflected in excessive lending concentrations, deteriorating financial ratios, tracking loan recoveries to gross loan charge-offs, deposit rates higher than market rates, off-balance sheet liabilities, delayed financials, change in auditors, change in management, use of political influence, rumors in the money market, share price volatility and deterioration of the economy. To Beltratti and Stulz (2009), poor bank and country-level governances, poor country-level regulation, poor balance sheet status and low profitability contributed to the poor performances of banks across countries. Specifically, Kiff and Mills (2007) attributed the banking crises in the US in 2000's to increasing inflation in the housing market. Adding, kwan and Eisenbeis (1995) noted that under-capitalised banks took high risk which they could not absorb, supporting earlier arguments by Kim and Santomero (1988) and Koehn and Santomero (1980). Commenting, Vilen (2010) noted that though many banks in the US failed in 1985, the problem originated from the 1960's with deregulation of the US banking sector to the early 1980's. This to him, increased competition among banks resulted in the introduction of sharp practices in the sector and 'cooking' of the books, both negatively affecting bank profit. To Epig (2009), the gravity of the crises was most felt in 2008 with the failure of Lehman Brothers which revealed the seriousness and depth of the financial crises. Using bank loan portfolios, Gonzalez-Hermosillo (1999) concluded that banks with high level of commercial and industrial loans relative to total loans suffered more severe losses than banks with more conservative loans. To reduce risk exposures, Furlong and Keely (1990) recommended an increase in banks' capital base. Governments across the globe also introduced bail-outs to banks to curtail the negative effects of bank bankruptcies on their economies. These recurring bankruptcies make necessary the continual assessment of the financial status of deposit money banks operating in a country.

Empirical tests of models' efficacies in predicting corporate failures in US, Europe and Asia abound in bankruptcy literature. These models are the Altman z-score, multiple discriminant analysis, the logistic analysis, the artificial neural network, factor analysis and the multiple regression analysis. Erdogan (2008) used the logistic regression model with relevant ratios which predicted bank bankruptcies between 1997 and 1999 in Turkey. Using the same set of banks during the period 2000 – 2001, Erdogan (2008) concluded that the neurofuzzy prediction model outperform the multiple discriminant analysis (MDA) and the artificial neural network (ANN) prediction models in predicting bank failures in Turkey. Beaver (1966) used the financial ratios, Sinkey (1975) the MDA, Meyer and Pifer (1970) the multiple regression analysis (MRA), Martin (1977) and Ohlson (1980) the logistic regression analysis, West (1985) the factor analysis; Cielen et al (2004) and Kao and Liu (2004), Tan and Diharjo (2001), Swicegood and Clark (2001), Alam et al (2000), Yang et al (1999), Zhang et al (1999), Bell (1997), Tsukuda and Baba (1994), Wilson and Sharda (1994), the artificial neural networks; and Lanine and Vennet (2006) and Kolari et al (2002) the trait recognition model. Bellovary et al (2007) concluded from their study of bankruptcy prediction results from 1930 to 2007 that the Altman's (1968) MDA is more accurate; cautioning against the use of multiple factors in any bankruptcy prediction model as two factors are capable of predicting firm distress as with model using 21 factors. This argument is supported by findings of Pang and Kogel (2013) from their study of US retail business with a 97.5% accuracy of Altman's (1968) model predictions.

3.0 Research methodology

3.1 Population for the study

The population for this study is the 21 deposit money banks in Nigeria.

3.2 Study samples and sampling technique

The two-stage sampling technique was used for this study.

Stage 1: the six CBN declared unsound banks in 2011 were purposively sampled.

Stage 2: four of the CBN declared unsound banks in 2011 were sampled using the stratified sampling technique as they occupy the top strata of unsound banks in Nigeria.

Thus two of the existing three bridge banks (Keystone Bank Ltd and Mainstreet Bank Ltd) set up by the Central Bank of Nigeria in 2011 to take over the nationalized banks: Bank PHB Plc and Afribank Plc respectively; and Wema Bank Plc, and Union Bank Plc are used for this

study. The sampled banks were suddenly declared unsound by the Central Bank of Nigeria without any publicly known signs of financial crises to the shock of shareholders and the banking public.

3.3 Sources of data

Data for this study are ratios computed from secondary data obtained from published annual reports of sampled 2011-classified unsound banks.

3.4 Validity and reliability of data

Secondary data from annual reports of sampled banks used for this study were prepared to meet the requirements of the Companies and Allied matters Act, 1999, the Banking Act, the Nigerian Stock Exchange annual information disclosure requirements (as sampled unsound banks are/were quoted banks), and audited by their external auditors making data obtained therefrom valid and reliable.

3.5 Data analysis technique and model justification

To determine the existence of financial distress in the two sampled bridge banks two years prior to their takeover by the CBN in 2011 and two years after, and two other 2011 non-nationalised unsound banks, we use the Altman's z-score discriminant analysis model on the relevant Altman (1968) z-score ratios computed from their annual reports from 2010-2013. This model was successful in bankruptcy prediction studies by Kyriazopoulos et al (2012), Sinkey (1975), Meyer and Pifer (1970), and Beaver (1966). Salmi and Martikainen (1994) argued that corporate financial data are preferable for use in models for predicting corporate failures; suggesting that such data should be financial ratios, making its use in this study accurate. Specifically, this study uses ratios capable of determining the financial health of firms (liquidity and profitability ratios) as used in similar studies (du Jardin, 2009; Back et al 1994, Salmi and Martikainen, 1994; Odom and Sharda, 1990; Zavgren, 1985; Zmijewski, 1984; Lev and Sunder, 1979; and Altman, 1968).

Values for z-score variables' components and overall z-score for sampled banks are shown in tables 1-4 where WC= net working capital, TA=total assets, RE=retained earnings, EBIT=earnings before interest and taxes, MVE=market value of equity, BVD=book value of debt, and T=turnover.

Table 1: Wema Bank Plc annual Z-scores

z-score variables	2013	2012	2011	2010
WC/TA	-0.71	-0.87	-0.53	-0.37
RE/TA	-0.11	-0.15	-0.16	-0.15

EBIT/TA	0.0031	0.022	-0.033	0.06
MVE/BVD	0.34	0.11	0.13	0.13
T/TA	0.06	0.07	0.12	0.10
Z	0.417	-0.818	-0.473	-0.23

The Altman z-score values for Wema Bank Plc improved from steadily from -0.23 in 2010 to +0.417 in 2013 (table 1).

Table 2: Union Bank Plc annual Z-scores

z-score variables	2013	2012	2011	2010
WC/TA	-0.49	-0.50	-0.49	-0.82
RE/TA	-0.29	-0.30	-0.34	-0.29
EBIT/TA	0.066	0.026	-0.08	0.10
MVE/BVD	0.11	0.10	0.10	0.03
T/TA	0.04	0.02	0.09	0.14
Z	-0.56	0.246	-0.72	-0.84

The Altman z-score values for Union Bank Plc for the study period fluctuated from -0.84 to -0.72 to +0.246 and -0.56 (table 2).

Table 3: Mainstreet Bank Ltd annual Z-scores

z-score variables	2013	2012	2011 (As AfriBank Nig Plc)	2010(As AfriBank Nig Plc)
WC/TA	-0.32	-0.39	-0.41	-0.40
RE/TA	0.02	0.01	-0.37	-0.501
EBIT/TA	0.03	0.07	0.09	0.091
MVE/BVD	0.58	2.66	1.10	1.17
T/TA	0.14	0.16	0.10	0.12
Z	0.45	2.51	0.51	0.48

Mainstreet Bank Ltd's Altman z-score for the study period also fluctuated, increasing from +0.48 in 2010 to +0.51 in 2011 to +2.51 in 2012, declining to +0.45 in 2013 (table 3).

Table 4: Keystone Bank Ltd annual Z-scores

z-score variables	2013	2012	2011	2010
WC/TA	-0.50	-0.53	-0.55	-0.70
RE/TA	0.03	-0.02	0.02	0.00
EBIT/TA	0.07	0.04	0.03	-0.58
MVE/BVD	0.21	0.17	0.14	0.05
T/TA	1.69	1.59	0.08	-0.43
Z	1.50	1.25	-0.28	-0.26

The Altman z-score for Keystone bank Ltd increased steadily from -0.26 in 2010 to +1.50 in 2013 (table 4).

4.0 Research results and policy implications of findings

The Altman Z-score for the four sampled banks for the four were < 1.99 showing that they were in a bankrupt position throughout the study period. Thus we accept H_0 i.e. the 2011-unsound banks are not yet financially sound. The Altman Z-score for Wema Bank Plc worsen from -0.23 in 2010 to -0.473 in 2011, and further to -0.818 in 2012, increasing significantly to +0.417 in 2013 (fig 1); but still below the minimum threshold of 2.675 indicating that the bank is still in a gross bankrupt position which portends danger to Nigeria's financial system. Union Bank Nig Plc had a fairly improved result (though all negatives) from 2010-2013 with the Altman Z-score improving from -0.84 in 2010 to -0.72 in 2011, -0.654 in 2012 and -0.56 in 2013 (fig 1). The negative values for the years show the poor financial state of the bank in a grossly bankrupt position.

Fig1: Altman Z-score trend of sample banks

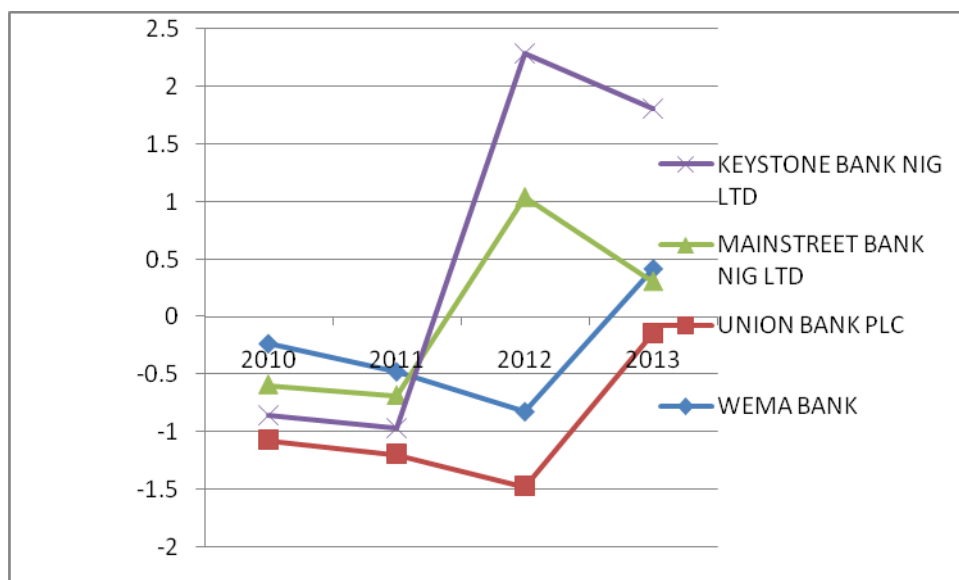

Keystone Bank Ltd (formerly BankPHB Plc) improved from a negative Z-score value of -0.26 in 2010 and -0.28 in 2011 before its takeover by the CBN to +1.25 in 2012 and +1.50 in 2013 after the takeover (fig 1). Though still in a bankrupt position, the positive results after the takeover shows improved financial status of the bank which seemed attributable to the exercise of this administrative function by the CBN with attendant spiral effects on the financial sector. Mainstreet Bank Ltd (formerly AfriBank Nig Plc) had a steadily improved result from 2010 and 2011 of +0.48 and +0.51 respectively before its takeover by the CBN to +2.51 (in grey area of the Altman Z-score map) in 2012 which showed a positive effect of the takeover by the CBN on the financial situation of the bank. The financial situation of the bank worsened in 2013 with the fall of the Altman Z-score to +0.45 (fig 1), indicating the deepening the bankruptcy crisis of the bank.

The two banks taken over by the CBN AfriBank Nig Plc and BankPHB Nig Plc showed improved financial status after the CBN takeover (though were still bankrupt) indicating the effectiveness of the performance of the regulatory functions by the CBN on the deposit money banks with positive effects on the banks with positive spiral effects on the financial sector of the Nigerian economy. Two distressed banks at 2011: Wema Bank Plc and Union Bank Plc not taken over by the CBN remained in a grossly bankrupt position (with Altman z-score <1.99 for the study period) exposing the error of the apex bank in 2011 with its non-takeover of both banks to instill administrative and financial discipline, and reverse the financial distress of both banks. The bankrupt positions of both banks with their continuous existence, portends danger to Nigeria's financial sector because of the contagious effects of these banks on other banks and the entire financial sector.

5.0 Conclusions and recommendations

From this study, we conclude that 4 of the 21 deposit money banks in Nigeria: Wema Bank Nig Plc, Union Bank Nig Plc, Mainstreet Bank Nig Ltd (formerly Afribank Nig Plc) and Keystone Bank Nig Ltd (formerly BankPHB Plc) declared financially distressed by the CBN in 2011 are still in a grossly poor financial state, are unsound and bankrupt. The failure of the general broad-based monetary policies introduced by the CBN for these banks make necessary the introduction of bank-specific monetary and financial policies to solve identified bank-specific problems, and the direct supervision of these banks by the CBN with daily monitoring of their operations.

To avert the negative financial effects of these banks on the banking public, economic development of Nigeria and contagious effects on other banks in the sector and financial system, the apex bank should improve

on and regularly assess the financial status of deposit money bank in Nigeria (especially these four banks), takeover Union Bank Plc and Wema Bank Plc and turn around their financial status as fairly done with Keystone Bank Ltd and Mainstreet Bank Ltd; and suspend the proposed sale of the nationalized banks until they are financially sound.

References

- Aharony, J; Jones, C.P. and Swary, I. (1980). "An analysis of risk and return characteristics of corporate bankruptcy using capital market data". *The Journal of Finance*, 35(4), 1001-1016.
- Alam, P.D; Booth, K.L. and Thordarson, T. (2000). "The use of fuzzy clustering algorithm and self-organising neural networks for identifying potentially failing banks: An experimental study". *Expert Systems with Applications*, 18, 185-199.
- Altman, E.I. (1993). *Corporate Financial Distress: A complete Guide to Predicting and Dealing with Bankruptcy*. New York: John Wiley & Sons.
- Altman, E.I. (1983). *Corporate Financial Distress and Bankruptcy*. New York: John Wiley & Sons.
- Altman, E. I. and Brenner, M. (1981). "Information effects and stock market response to signs of firm deterioration". *The Journal of Financial and Quantitative Analysis*, 16(1), 35-41.
- Altman, E.I. (1968). "Financial ratios, discriminant analysis and the prediction of corporate bankruptcy". *Journal of Finance*, 23(4), 589-609.
- Argenti, J. (1976). *Corporate Collapse: The Causes and Symptoms*. New York: Halsted Press Wiley.
- Arora, N. and Saini, J. (2013). "Time series model for bankruptcy prediction via adaptive neuro-fuzzy inference system". *International Journal of Hybrid Information Technology*, 6(2), 51-63.
- Atiya, A. F. (2001). "Bankruptcy prediction for credit risk using neural networks: A survey and new results". *IEEE Transactions on Neural Networks*, 12(4), 929-935.
- Aziz, A; Emmanuel, D.C. and Lawson, G.C. (1988). "Bankruptcy prediction: An investigation of cash flow based models". *Journal of Management Studies*, 25(5), 419-437.
- Back, O; Oosterom, G; Sere, K. and Van Wezel, M. (1994). "A comparative study of neural networks in bankruptcy prediction". Proceedings of the 10th Conference on Artificial Intelligence Research in Finland, Finnish Artificial Intelligence Society, Pp 140-148.
- Beaver, W. H. (1968). "Market prices, financial ratios, and the prediction of failures". *Journal of Accounting Research*, 6(2), 179-192.

Beaver, W. H. (1966). "Financial ratios as predictors of failure". *Journal of Accounting Research*, 4(1), 71-111.

Bell, T.B. (1997). "Neural nets or logit model: A comparison of each model's ability to predict commercial bank failures". *International Journal of Intelligent Systems in Accounting*, 6, 249-264.

Bellovary, J; Giacomino, D. and Akers, M. (2007). "A review of bankruptcy prediction studies: 1930-present". *Journal of Financial Education*, 33, 1-42.

Bernhardsen, E. (2001). "A model of bankruptcy prediction". Working Paper, Norbes Bank, Oslo, Norway.

Betz, F; Oprica, S; Pettonen, T.A. and Sarlin. P. (2013). "Predicting distress in European banks". European Central Bank Working Paper No 1597. Retrieved from www.ecb.europa.eu on 17/2/15.

Blazy, R. and Combier, J. (1997). "La de'faillance d'entreprise: causes e'conomiques, traitement judiciaire et impact financier". *Economica*.

Cielen, A; Peters, L. and Vanhoof, K. (2004). "Bankruptcy predictions using a data envelopment analysis". *European Journal of Operations Research*, 154, 526-532.

Clark, T.A. and Weinstein, M. I. (1983). "The behaviour of the common stock of bankrupt firms". *The Journal of Finance*, 38(2), 489-504.

du Jardin, P. (2009). "Bankruptcy prediction models: How to choose the most relevant variables?" *Bankers, Markets & Investors*, 98, 36-46.

Ebiringa, O. T. (2011). "Benchmarking incidence of distress in the Nigerian banking industry on Altman scale". *Serbian Journal of Management*, 6(2), 221-230.

Erdogan, B.E. (2008). "Bankruptcy prediction of Turkish commercial banks using financial ratios". *Applied Mathematic Sciences*, 2(60), 2973-2982.

Hauser, R.P. and Booth, D. (2011). "Predicting bankruptcy with robust logistic regression". *Journal of Data Science*, 9, 565-584.

Horrigan, J.O. (1983). "Methodological implications of non-normally distributed financial ratios: factors associated with insolvency amongst small firms". *Journal of Business Finance and Accounting*, 10(4), 683-689.

Jordan, D.J; Rice, D; Sanchez, J; Walker, C. and Wort, D.H. (2010). "Predicting bank failures: Evidence from 2007 to 2010". SSRN Working Paper.

Kao, C.S. and Liu, T. (2004). "Prediction of bank performance with financial forecasts: *Journal of Banking & Finance*, 28, 2353-2368.

Keasey, K. and Watson, R.C. (1987). "Non-financial symptoms and the prediction of small company failure: A test of Argenti's hypothesis". *Journal of Business Finance and Accounting*, 14(3), 335-351.

Kolari, J; Glennon, D; Shin, H. and Caputo, M. (2002). "Predicting large US commercial bank failures". *Journal of Economics and Business*, 54(3)2, 361-387.

Kyriazopoulos, G; Kanta, K. and Mitou, K. (2012). "The Edward, I. Altman's model of bankruptcy and the implementation of it on the Greek Co-operative banks". *MIBES*, 25-27, 423-436.

Lanine, G. and Vennet, R.V. (2006). "Failure prediction in the Russian bank sector with logit and trait recognition models" *Expert Systems with Applications*, 30, 463-478.

Lev, B. and Sunders, S. (1979). "Methodological issues in the use of financial ratios". *Journal of Accounting and Economics*, 1(3), 187-210.

Lussier, R. N. (1995). "A non-financial business success versus failure prediction model for young firms". *Journal of Small Business Management*, 33(1), 8-20.

Madireddi, V. and Vadlamani, R. (2011). "Bankruptcy prediction in banks by principal component analysis threshold accepting trained wavelet neural network hybrid". *Proceedings of the 2011 International Conference on Data Mining*, 71-76.

Martin, A; Manjula, M. and Venkatesan, P. (2011). "A business intelligence model to predict bankruptcy using financial domain ontology with association rule mining algorithm". *International Journal of Computer Science Issues*, 8(2&3), 211-218.

Martin, D. (1997). "Early warning of bank failure: A logistic regression approach". *Journal of Banking and Finance*, 1, 249-276.

Meyer, P.A. and Pifer, H.W. (1970). "Prediction of bank failures". *Journal of Finance*, 25(4), 853-868.

Mossman, C.E; Bell, G.G; Swartz, L.M. and Turtle, H. (1998). "An empirical comparison of bankruptcy models". *Financial Review*, 33(2), 35-53.

Nidhi, A. and Saini, J. R. (2013). "Time series model for bankruptcy prediction via adaptive neuro-fuzzy inference system". *International Journal of Hybrid Information Technology*, 6(2), 51-63.

Odom, M. C. and Sharda, R. (1990). "A neural network model for bankruptcy". Proceedings of the IEEE International Joint Conference on Neural Networks, San Diego, California, 2,163-168.

Ohlson, J. (1980). "Financial ratios and the probabilistic prediction of bankruptcy". *Journal of Accounting Research*, 18, 109-131.

Pang, J. and Kogel, M. (2013). "Retail bankruptcy prediction". *American Journal of Economic and Business Administration*, 5(1), 29-46.

Perez, M. (2002). "De l'analyse de la performance a' la prevision de de'faillance: les apports de la classification neuronale". These de doctorat, Universite' Jean-Moulin Lyon III.

Platt, H.D. and Platt, M. B. (2002). "Predicting corporate financial distress: Reflections on choice-based sample bias". *Journal of Economics and Finance*, 26(2), 84-199.

Pompe, P. P. M. and Bilderbeek, J. (2005). "The prediction of small and medium sized industrial firms" *Journal of Business Venturing*, 20(6), 847-868.

Salehi, M. and Abedini, B. (2009). "Financial distress prediction in emerging market: Empirical evidences from Iran". *Business Intelligence Journal*, 2(2), 398-409.

Salmi, T. and Martikainen, T. (1994). "A review of the theoretical and empirical basis of financial ratio analysis". *Finnish Journal of Business Economics*, 4(94), 426-448.

Sanabar, A. (2012). "Business bankruptcy prediction models: A significant study of the Altman's Z score model". *Asian Journal of Management Research*, 3(2), 212-219.

Sinkey, J.F. (1975). "A multivariate statistical analysis of the characteristics of problem banks". *Journal of Finance*, 30, 21-36.

Spicewood, P. and Clark, J. A. (2001). "Off-site monitoring for predicting bank under performance: A comparison of neural networks, discriminant analysis and professional human judgement". *International Journal of Intelligent Systems on Accounting, Finance and Management*, 10, 169-186.

Sullivan, T.A; Warren, E. and Westbrook, J. (1998). "Financial difficulties of small businesses and reasons for their failure". US Small Business Administration Working Paper No SBA-95-0403.

- Tsukkuda, J.S. and Baba, I. (1994). "Predicting Japanese corporate bankruptcy in terms of finance data using neural network". *Computers and Industrial Engineering*, 27(1-4), 445-448.
- Tam, K. Y. and Kiang, M. Y. (1992). "Managerial applications of neural networks: The case of bank failure predictions". *Management Science*, 38(7), 926-947.
- Tan, N.W. and Diharjo, H. (2001). "A study on using artificial neural networks to develop an early warning predictor for credit union financial distress with comparison to probit model". *Managerial Finance*, 27(4), 56-77.
- Vaziri, M; Rafiqul, B. and Ponkala, A.V.M. (2012). "Comparative predictability of failure of financial institutions using multiple models". *Investment Management and Financial Innovations*, 9(2), 120-127.
- Vilen, M. (2010). "Predicting failures of large US commercial banks". M. Sc Thesis submitted to the School of Economics, Aalto University.
- West, R.C. (1985). "A factor analytic approach to bank condition". *Journal of Banking and Finance*, 9, 253-266.
- Wilson, R.L. and Sharda, R. (1994). "Bankruptcy predictions using the neural networks". *Decision Support Systems*, 11, 545-557.
- Yang, Z.R; Platt, M.B. and Platt, H.D. (1999). "Probabilistic neural networks in bankruptcy prediction". *Journal of Business Research*, 44(2), 67-74.
- Yildiz, B. and Akkoc, S. (2009). "Bankruptcy prediction using neuro-fuzzy: An application in Turkish banks". *NYSEA Proceedings*, 3, 143-154.
- Yildiz, B. and Akkoc, S. (2009). "Predicting bank bankruptcies with neuro-fuzzy method". *Journal of BRSA Banking and Financial Markets* 3(1), 338-353.
- Zavgren, C.V. (1985). "Assessing the vulnerability to failure of American industrial firms: A logistic analysis". *Journal of Business Finance and Accounting*, 12(1), 19-45.
- Zhang, G; Hu, M.Y; Paluwo, B.E. and Indro, D.C.(1999). "Artificial neural networks in bankruptcy predictions: General framework and cross-validation analysis". *European Journal of Operational Research*, 116(1), 6-32.
- Zmijewski, M.E. (1984). "Methodological issues related to the estimation of financial distress prediction models". *Journal of Accounting Research*, 22, 59-82.

INFLUENCE OF FORENSIC ACCOUNTING ON FRAUD DETECTION AND PREVENTION IN NIGERIA BANKING INDUSTRY - Salman, A. Y., Lawal, A. A., & Anjorin, S. Y.

ABSTRACT

*This study examined the influence of forensic accounting on fraud detection and prevention in Nigeria banking industry. Purposive sampling method was used to select 65 respondents from 13 merged deposit money banks in Ilorin, Kwara State, Nigeria. The main source of data was structured questionnaire. The questions were set to provide relevant information that can help in answering the research questions. Both descriptive and inferential statistics, such as percentage, mean and standard deviation, and regression analysis was adopted for data analysis. The result revealed that forensic accounting ($\beta = 0.557$, $t = 7.783^{**}$, $P < .01$) significantly influenced fraud detection and prevention. The result also revealed that forensic accounting has 55.1% decisive influence on fraud detection and prevention in Nigeria banking industry. Result also shows that usage of forensic accounting is still very low in the public sector especially in Nigeria banking industry. Result also confirmed that lack of rule of law, delay at court, weak law enforcement and lack of continuity on the part of investigating agencies were the major factors that hinders the application of forensic accounting techniques in fraud prevention and detection in Nigeria. The study concluded that forensic accounting is an antidote to financial malpractice in both private and public sectors especially in banking industry. Subsequently, recommendations were made on how forensic accounting should be implemented in both public and private sectors.*

Key words : Forensic Accounting, Fraud, Bank, Nigeria.

Introduction

The level of fraud in the present day Nigeria has assumed an epidemic dimension. Fraud is the number one enemy of the business world, no company is immune to it and it is in all works of life. The fear is now rife that the increasing wave of fraud in the financial institutions in recent years, if not arrested might pose certain threats to stability and the survival of individual financial institution and the performance of the industry as a whole and no area of the economy is immune from fraudsters and even the banking system. Fraud if not checked might cause run on in the banking sector. Rise in financial scandals at the beginning of the twenty-first century was associated with increased fraud incidence and awareness, thereby questioning the role of auditor in fraud prevention and detection (Bhasin, 2013). Onuorah and Appah (2011) also affirmed that the widespread frauds in modern organizations have made traditional auditing and investigation inefficient and ineffective in the detection and prevention of the various types of frauds confronting businesses world-wide especially in financial institutions. Fraud is an endemic that are gradually becoming a normal way of life in both public and private sectors, from the presidential cabinets, down to the political officer, to the ward councillors, from managing directors of companies, through middle management cadre and to lower managers in Nigeria (Gbegi and Adebisi, 2014).

Today, deposit money banks still witnessing several cases of collapses in Nigeria due to financial malpractices, unethical practices, insider abuses, poor quality services and weak supervisory structures, employment of unqualified staff, unhealthy competitions and recklessness amongst managers. These had eroded the confidence the depositors have in Nigerian banking sector. Fraud which literarily means a conscious and deliberate action by a person or group of persons with the intention of altering the truth or fact for selfish personal gain is now by far the single most veritable threat to the entire Nigeria banking industry. Forensic accounting has been identified as sophisticated approach from preventative to detection of fraud globally, Nigeria inclusive. The accounting profession is witnessing major changes due to changes in technology. In addition to the traditional accounting services, accountants are involved in such services such as attestation reviews, forensic accounting, and fraud examinations. Today's accountants must possess the knowledge to remain updated and the skills to critically analyze various problems (Shamsi 2011). According to Hansen (2009), computer forensics is currently the investigators best tools in detecting and implementation of white-collar investigations. Degboro and Olofinola (2007) described forensic accounting as the application of criminalistic methods, and integration of accounting investigative activities and law procedures to detect and investigate financial crimes and related

accounting misdeeds. According to Dhar and Sarkar (2010), forensic accounting, also called investigative accounting or fraud audit, is a merger of forensic science and accounting. Howard and Sheetz (2006) also described forensic accounting as the process of interpreting, summarizing and presenting complex financial issues clearly, succinctly and factually often in a court of law as an expert. It is concerned with the use of accounting discipline to help determine issues of facts in business litigation (Okunbor and Obaretin, 2010).

Based on this background, this paper intends to examine the influence of forensic accounting on fraud prevention and detection in Nigeria banking industry.

Research Question

The following research questions were the focus of this research paper:

- i. To what extent does forensic accounting influence fraud detection and prevention in money deposit banks in Nigeria?
- ii. What is the level of awareness of forensic accounting techniques among practitioners in Nigeria?
- iii. What are the major factors that hinder the application of forensic accounting in fraud prevention and detection in Nigeria?

Hypothesis

The following hypothesis was formulated for the study

H₀₁: Use of forensic accounting has no significant influence on fraud prevention and detecting prevention in money deposit banks in Nigeria.

REVIEW OF RELATED LITERATURE

Concept of Forensic Accounting

Forensic accounting is specialty practice area of accounting that describes engagements that result from actual or anticipated disputes or litigation. "Forensic" means "suitable for use in a court of law", and it is to that standard and potential outcome that forensic accountants generally have to work. Forensic accountants, also referred to as forensic auditors or investigative auditors, often have to give expert evidence at the eventual trial. Owojori and Asaolu (2009) analyzed that forensic accounting through forensic accountants provide litigation support service which is the provision of assistance of an accounting nature in a manner involving existing or pending litigations in the areas of quantification of economic damages, calculating economic loss resulting from a breach of contract.

Association of Certified Fraud Examiners (2010) defined forensic accounting as the use of skills in potential or real civil or criminal disputes, including generally accepted accounting and auditing principles in establishing losses of profit, income, property or damage, estimations of internal controls, frauds and others that involve inclusion of accounting expertise into the legal system . Hence, forensic accounting involves the application of accounting concepts, auditing techniques and investigative procedures in solving legal problems

According to Hansen (2009), computer forensics is currently the investigators best tools in detecting and implementation of white-collar investigations. Degboro and Olofinsola (2007) described forensic accounting as the application of criminalistic methods, and integration of accounting investigative activities and law procedures to detect and investigate financial crimes and related accounting misdeeds. According to Dhar and Sarkar (2010), forensic accounting, also called investigative accounting or fraud audit, is a merger of forensic science and accounting. Howard and Sheetz (2006) also described forensic accounting as the process of interpreting, summarizing and presenting complex financial issues clearly, succinctly and factually often in a court of law as an expert. It is concerned with the use of accounting discipline to help determine issues of facts in business litigation (Okunbor and Obaretin, 2010). Forensic science according to Crumbley (2003) "may be defined as application of the laws of nature to the laws of man." He refers to forensic scientists as examiners and interpreters of evidence and facts in legal cases that also requires expert opinions regarding their findings in court of law. The science in question here is accounting science, meaning that the examination and interpretation will be of economic information. According to Webster's Dictionary, forensic accounting means "Belonging to, used in or suitable to court, of judicature or to public discussions, debate and ultimately dispute resolutions". It is also defined as an accounting analysis that is suitable to the court which will form the basis of discussion, debate and ultimately dispute resolution. Forensic accounting also called investigative accounting or fraud audit is a merger of forensic science and accounting. Forensic accounting is the practice of utilizing accounting; auditing and investigative skill to assist in legal matter and the application of specialized body of knowledge to the evidence of economic transaction and reporting suitable is the purpose of establishing accountability or valuation of administrative proceedings.

Concept of fraud

Fraud is a complex universal phenomenon. It is rampant in both developed and developing countries and varies across time and places in

its magnitude, its sources, the way it manifests itself and in its effects on administrative performance and development. Political, economic, social, cultural and attitudinal factors combine in contributing to its incidence. Oyejide (2008) opine that fraud is a subject that has received a lot of attention both globally and in Nigeria. This interest has been heightened by several high profile cases involving several organizations. Issues relating to fraud have also been the subject of rigorous theoretical and empirical analysis in the academic literature (Appah and Appiah, 2010). According to Karwai (2002) maintains that the increasing wave of fraud is causing a lot of havoc in Nigeria. This is because fraud has eaten deep into every aspect of the Nigerian society to the extent that many organizations have lost confidence of their customers. In the words of Adesola (2008), the threat of fraud to the global economy is better illustrated by the statistics released by Criminologists at a consultancy: over two hundred thousand cases of online frauds were committed in the United Kingdom in 2006, doubled the amount of real world robberies. The study revealed that 75% of card not present fraud was committed on-line in 2006. Okunbor and Obaretin (2010) reported that the spates of corporate failures have placed greater responsibility and function on accountants to equip themselves with the skills to identify and act upon indicators of poor corporate governance, mismanagement, frauds and other wrong doings. It has become imperative for accountants at all levels to have the requisite skills and knowledge for identifying, discovering as well as preserving the evidence of all forms of irregularities and fraud.

Fraud has become a parasite in Nigeria banking industry, for example, in November, 2005; the CBN blacklisted six officers of banks, including a chairman and a non-executive director, for unethical practices and professional misconduct. The same year, 110 cases of fraud and forgeries totaling N1.5 billion were reported by various Banks; and fifty six (56) of the cases amounted to N 1.38 billion, representing 91.8% of the total amount (N1.50B) {CBN annual report, 2006. Okafor (2004) reported that fraud is a generic term and embraces all the multifarious means which human ingenuity can devise, which are resorted to by one individual to get advantage over another in false representation. No definite and invariable rule can be laid down as a general proposition in defining fraud as it includes surprise, trick, cunning and unfair ways by which another is cheated. According to Anyanwu (1993), fraud is an act or course of deception, deliberately practiced to gain unlawful or unfair advantage; such deception directed to the detriment of another. Legally, fraud has been defined as the act of depriving a person dishonestly of something, which is, or of something to which he is or would or might be entitled but for the perpetration of fraud. Karwai (2002), Anyanwu (1993), Okafor (2004) and Adeniji (2004) cited in Onurah and Appah

(2011) summarize the types of fraud on the basis of methods of perpetration include the following but not exhaustive as the methods are devised day in-day out to include: defalcation, suppression, outright theft and embezzlement, tampering with reserves, insider abuses and forgeries, fraudulent substitutions, unauthorized, unauthorized lending, lending to ghost borrowers, kite flying and cross firing, unofficial borrowing, impersonation, teeming and lading, fake payment, fraudulent use of the firms documents, fictitious accounts, false proceeds of collection, manipulation of vouchers, dry posting, over invoicing, inflation of statistical data, ledger accounts manipulation, fictitious contracts, duplication cheque books, computer fraud, misuse of suspense accounts, false declaration of cash

shortages etc.

Relationship between forensic accounting, fraud detection and prevention

Several studies have carried out on the relationship between forensic accounting and fraud detection in Nigeria. For instance, Onurah and Appah (2011) examined the effect of forensic accounting services on fraud detection in Nigerian banks. To achieve this objective, data was collected from primary and secondary sources. The primary data were collected with the help of a well structured questionnaire of three sections administered to twenty four banks in Port Harcourt the capital of Rivers State and the data collected from the questionnaires were analysed with descriptive statistics, Augmented Dickey-fuller, ordinary least square and Granger Causality. The result revealed that the application of forensic accounting services affects the level of fraudulent activities of banks.

Tarig, Moayad, Sofri and Ala (2013) also determined the impact of using forensic accounting on financial corruption. This study adopted a correlation research design. Data was collected by using interviews and questionnaires. The study revealed that there is a significant relationship between the forensic accounting methods and effectiveness of the control and auditing bodies to detect financial corruption cases. Ifeanyi and Joseph (2013) also investigated the effect of forensic accounting on corporate fraud and performance outcome in the Nigerian manufacturing sector. Using a match sample of 306 manufacturing firms registered with the Manufacturing Association of Nigeria (MAN). Result revealed that use of forensic accounting has significant effect on corporate fraud reduction.

Okoye and Gbegi (2013) also examined forensic accounting as a tool for fraud detection and prevention in the public sector organizations with particular reference to Kogi State. Both primary and secondary sources of data were appropriately used. The statistical tool used to test

hypotheses was Analysis Of Variance (ANOVA). The result showed that the use of Forensic Accounting do significantly reduces the occurrence of fraud cases in the public sector, and that there is significance difference between Professional Forensic Accountants and Traditional External Auditors and therefore the use of Forensic Accountants can help better in detecting and preventing fraud cases in the public sector organizations. In the same vein, Dada, Owolabi and Okwu (2013) also investigated the relevance of forensic accounting in the effective reduction in fraudulent practices in Nigeria. The study employed multiple regression technique to analyze the empirical data collected through questionnaire and oral interview and the hypothesis formulated was also tested. The results of the hypotheses tested revealed that fraud reduction is significantly and positively related to fraud investigation and detection through forensic accounting.

Research methodology

Purposive sampling method was used to select respondents. The study was based on a sample size of 65 respondents comprising; Banks Managers, Accountants, and Auditors. The research sample was included 13 merged deposit money banks (Access bank, Diamond bank, Eco bank Nigeria limited, Enterprise bank limited, Fidelity bank, First bank of Nigeria, First city monument bank, Keystone bank, Mainstreet bank, Skye bank, Stanbic IBTC bank Nigeria Ltd., Sterling bank, Union bank Plc, United bank for Africa Plc, and Unity bank plc) in Ilorin, Kwara State. The main source of data was structured questionnaire. The questions were set to provide relevant information that can help in answering the research questions. Both descriptive and inferential statistics, such as percentage, mean and standard deviation, and regression analysis was adopted for data analysis.

Results and Discussion

Table 1: Influence of Pay Satisfaction on Organizational Commitment

Model	R	R-square	Adjusted R ²			Standard error of the estimate	
1	0.74	0.551	0.549			6.519	
	2						
Explanatory variable			B	Std error	t value	-p- value	Remarks

Constraint	10.050	1.291	7.783	0.000	
Forensic Accounting	0.557	0.026	21.030 **	0.000	S

S= Significant; ** = significant at 1% level

Source: Data Analysis, 2015

The result of analysis in the Table 1 indicated that forensic accounting ($\beta = 0.557$, $t = 7.783^{**}$, $P < .01$) significantly influenced fraud detection and prevention. The result also revealed that forensic accounting has 55.1% decisive influence on fraud detection and prevention in Nigeria banking industry. This implies that usage of forensic accounting is an antidote to financial reckless in banking industry. This result is consistent with Okoye and Gbegi (2013), Dada, Owolabi and Okwu (2013), Onuorah and Appah (2012), Ifeanyi and Joseph (2013) and Tarig, Moayad, Sofri and Ala (2013) that use of Forensic Accounting can help better in detecting and preventing fraud cases in the public sector organizations.

Table 2: Accounting practitioners' level of awareness of forensic accounting

	Frequency	Percent	Valid Frequency	Cumulative Frequency
Very Low	10	15.4	15.4	15.4
Low	35	53.8	53.8	69.2
Moderate	15	23.1	23.1	92.3
High	5	7.7	7.7	100
Very high	0	0	0	

Sources: Field Survey, 2015

On further exploration into the level of awareness, it is discovered in table 2 that 140 respondents (15.4 per cent) have very low awareness level, 35 respondents (53.8 per cent) have low level of awareness while 15 respondents (23.1 percent) have moderate level of awareness. However, only 5 respondents (7.7 percent) have high rate level of awareness. This implies that usage of forensic accounting is still very low in the banking industry. The study is in agreement with Efiog (2013) that the usage of forensic accounting implementation in Nigeria is low.

Table 3: Distribution of Respondents by Factors that Hinder the Application of Forensic Accounting.

Variable	Weighted Mean Score (WMS)	Rank
Lack of forensic accounting professional	3.67	6 th
Delay at Court	4.39	2 nd
Lack of continuity on the part of investigation Agencies	4.01	5 th
Lack of quality forensic analysis	3.45	7 th
Weak infrastructural base	3.07	9 th
Forensic accounting is expensive	2.99	11 th
Lack of effecient rule of law	4.45	1 st
Weak judicial system	4.22	4 th
Lack of experience	3.02	10 th
Weak law enforcement	4.28	3 rd
It is technology driven	3.15	8 th

Source: Field Survey, 2015

Table 3 presented the distribution of respondents by factors that hinder the application of forensic accounting in Nigeria. It was revealed that lack of effecient rule of law (WMS = 4.45) was ranked highest among the respondents followed by delay at court (WMS = 4.39); weak law enforcement (WMS = 4.28); weak judicial system (WMS = 4.22); lack of continuity on the part of investigation agencies (WMS = 4.01); lack of forensic professional (WMS = 3.67); lack of quality forensic analysis (WMS = 3.45); it is technology driven (WMS = 3.15); weak infrastructural base (WMS = 3.07); lack of experience (WMS = 3.02) and forensic accounting is expensive (WMS = 2.99). This implies that lack of rule of

law, delay at court, weak law enforcement and lack of continuity on the part of investigating agencies were the major factors that hinders the application of forensic accounting techniques in fraud prevention and detection in Nigeria. The result is consistent with Efiog (2013) that judiciary system in Nigeria is major factor that give room for fraud in public and private sectors.

Conclusion

Based on the findings of the study, it can be concluded that the use of forensic accounting is one of major mechanisms in detecting and preventing fraud in both private and public sector especially in banking industry. Result also confirmed that usage of forensic accounting is still very low in the banking industry. Result also confirmed that lack of effecient rule of law, delay at court; weak law enforcement and lack of continuity on the part of investigating agencies were the major factors that hinders the application of forensic accounting techniques in fraud prevention and detection in Nigeria. The deduction to be made from these findings is that usage of forensic accounting and effective judicial system may curb financial malpractices in Nigeria banking industry.

Recommendations

Based on the findings and conclusion, it is therefore recommended that:

1. Nigerian tertiary institutions and accounting professional bodies should take up courses in forensic accounting education. This would lead to increase awareness and subsequent use of the techniques in fraud prevention and detection.
2. Staff should attend conferences and seminars within and outside the country on forensic accounting.
3. Anti-corruption agencies in Nigeria such as EFCC, ICPC should be restructured by the government for better performance.
4. Financial reporting council should also ensure that best standards and regulations are established to ensure best practice and service delivery in banking industry
5. Government at these levels should provide the enabling environment for forensic accounting profession to thrive in the country by strengthening the legal, educational and political frameworks in the country (Nigeria) to move with the global trend in fraud prevention and detection.

REFERENCES

- Adesola, A., (2008). Government's anti-corruption initiative: The role of computer assisted audit techniques in fraud detection and prevention. *Niger. Account.*, 41(1): 16-19.
- Anyanwu, J.C., 1993. *Monetary Economics: Theory, Policy and Institutions*. Hybrid Publishers, Onitsha.
- Appah, E. and Z.K.A. Appiah, 2010. Fraud and the development of sound Financial Institutions in Nigeria. *Nigerian J. Dev. Res.*, 1(1): 49-56.
- Association of Certified Fraud Examiners (ACFE) (2010). *Fraud Examiners Manual (Intentional)* Association of Certified Fraud Examiners (ACFE). London: McGraw Publishers.
- Bhasin, M. (2013) Survey of skills required by forensic accountants: evidence from a developing country. *International Journal of Contemporary Business Studies*, 4 (2), pp. 54 - 86.
- Crumbley, D.L. (2003). "What is Forensic Accounting". Retrieved from www.edwardspub.com
- Dada, S.O, Owolabi, S.A and Okwu, A.T (2013). Forensic Accounting a Panacea to Alleviation of Fraudulent Practices in Nigeria. *Int.J.Buss.Mgt.Eco.Res.*4(5);787-792
- Degboro, D., & Olofinsola, J. (2007). Forensicaccountants and the litigation support engagement. *Niger. Account*, 40(2), 49-52.
- Dhar, P. and A. Sarkar, (2010). Forensic accounting: An accountant's vision. *Vidyasagar University J. Commerce*, 15(3): 93- 104.

- Efiong, E. J. (2013) Forensic Accounting Education: An Exploration of Level of Awareness in Developing Economies-Nigeria as a Case Study. *International Journal of business and management*, 7(4), p26-34.
- Gbegi, D.O and Adebisi, J.F. (2014). Forensic Accounting Skills and Techniques in Fraud Investigation in the Nigerian Public Sector. *Mediterranean Journal of Social Sciences* 5(3); 244-253.
- Hansen, L.L., 2009. Corporate financial crime: Social diagnosis and treatment. *J. Financial Crime*, 16(1): 28-40.
- Howard, S. and M. Sheetz, 2006. *Forensic Accounting and Fraud Investigation for Non-Experts*. John Wiley and Sons Inc, New Jersey.
- Ifeanyi, M and Joseph, M.O (2013). Forensic Accounting: a Relief to Corporate Fraud. *Research Journal of Finance and Accounting*. 4(14); 43-51.
- Karwai, S.A., 2002. Bank Fraud: Can Shari'ah prevent it? *J. Business Administration*, 2(1): 62-78.
- Okafor, B., (2004). Strategic approach to reduction of employee, theft fraud and embezzlement. *Niger Account.*, 37(4): 3-5.
- Okoye, E.I, and Gbegi, D.O (2013). Forensic Accounting: A Tool for Fraud Detection and Prevention in the Public Sector. (A Study of Selected Ministries in Kogi State). *International Journal of Academic Research in Business and Social Sciences*. 3(3); 1-18.
- Okunbor, J.A. and Obaretin, O. (2010) Effectiveness of the application of forensic accounting services in Nigeria corporate organisations. *AAU JMS*, 1 (1), pp. 171 - 18.

Onuorah, C and Appah. E (2012). Fraudulent Activities and Forensic Accounting Services of Banks in Port Harcourt, Nigeria. *Asian Journal of Business Management* 4(2): 124-129, 2012

Oyejide, A., 2008. Corruption and development: A Nigerian perspective. *Niger. Account.*, 41(4): 28-42.

Shamsi.B (2011). Forensic Accountants in the Digital Age. *Interdisciplinary Journal of Contemporary Research in Business*. 3(3); 75-87.

Tarig, Y.A, Moayad, M.A and Ala, M.R (2013). The Role of Forensic Accounting in Reducing Financial Corruption: A Study in Iraq. *International Journal of Business and Management*; 9(1); 26 -34.

THE EFFECT OF OWNERSHIP CONCENTRATION AND BOARD COMMITTEES ON FINANCIAL PERFORMANCE: EVIDENCE FROM TURKISH AND NIGERIAN LISTED COMPANIES

Dr. İрге ŞENER
Department of Management
Cankaya University, Turkey
Ankara, Turkey.
EMAIL: irge@cankaya.edu.tr

AND

Abubakar Balarabe KARAYE
Department of Accounting and Finance
Northwest University Kano,
Kano State, Nigeria.
EMAIL: abkaraye501@yahoo.com

Abstract

This study examines the effect of corporate governance internal mechanisms which include board committees and ownership structure on the financial performance of corporations in Nigeria and Turkey. These two countries are the members of the Next Eleven countries popularly known as N-11, and also they form part of the popular acronym of MINT (Mexico, Indonesia, Nigeria and Turkey). This study aims to contribute to the literature by comparison of these important internal governance dimensions between Turkey and Nigeria. The data used in this study is that of 2012, which consist of 120 corporations listed in Borsa Istanbul and 94 Nigerian listed corporations, linear regression analyses and t-test were used to analyze the data. The findings indicate that there is a significant effect of presence of corporate governance committee in the board of corporations on financial performance. Besides, there exist significant differences between Turkish and Nigerian corporations in terms of the number of directors in the audit committee and existence of corporate governance committee, whereas no significant differences are

present between the two countries regarding existence of risk management committee and block holdings of corporations' shares.

Keywords: Board Committees; Ownership Structure; Turkey; Nigeria

1. Introduction

Corporate governance attract substantial attention both from regulatory bodies, researchers and public due to a series of high-failure corporate scandals. Most of the research on corporate governance is based on agency theory. The main focal point of agency theory has been the potential conflict that arises between management and ownership; and the role of board of directors to monitor both the management and the majority shareholders (Fama and Jensen, 1983). According to agency theory, in order to overcome agency conflict, companies employ governance mechanisms. Therefore corporate governance mainly concentrate on issues arising from the separation of ownership and control. Corporate governance mechanisms are either internal or external. Recent debates on the effectiveness of corporate governance mechanisms have been centered to the functioning of the board of directors of firms and ownership concentration of corporations (Andres, Azofra and Lopez, 2005; Mandacı, and Gümüş, 2010).

Research and surveys on corporate governance is mostly conducted in developed countries such as UK, USA and European countries. On the other hand, there are limited amount of research in this area in developing countries and emerging market economies. Within this frame, this study is aimed to analyze the board committees and ownership structure in Turkish and Nigerian listed-companies. This research is very significant in that, it is one of the first of its kind that compare these internal corporate governance mechanisms in Turkey and Nigeria. These two countries are the members of the Next Eleven countries popularly known as N-11. Although, these countries have significant differences in location, institutional background, firm's characteristics and gender regime (Dang et al, 2012), the two countries form part of the popular acronym of MINT (Mexico, Indonesia, Nigeria and Turkey). According to Matthew Boesler (2013) this acronym was created by Jim O'Neil who was

also the inventor of BRICS economies acronym, he stated in his report about MINT economies that "...Mexico, Indonesia, Nigeria and Turkey all have very favorable demographics for at least the next 20 years, and their economic prospects are interesting". This study begins with the state of corporate governance environment in Turkey and Nigeria followed by literature review about board committees and ownership structure, after which the methodology and findings of the research is presented and the paper concludes with the discussion of the findings.

2. Corporate Governance Environment in Turkey and Nigeria

2.1 Corporate Governance Environment in Turkey

Corporate governance is mainly governed by the provision of OECD and Capital Markets Board (CMB) in Turkey. CMB regulates the activities of the corporations listed in Borsa Istanbul. One of the significant contributions of CMB is the issuance of Corporate Governance Guidelines in 2003 which was reviewed in 2005 and the change of accounting and auditing standards to International Financial Reporting Standards in 2005. OECD guidelines and principles are applicable for all corporations in the OECD countries not only necessarily quoted corporations. Turkish Commercial Law also plays a significant role in the improvement of corporate governance in Turkey. Evident of this improvement can be glanced from the proposition of this law in 2005, the Law proposed significant changes and reforms for corporate governance in Turkey. The result of the proposition was the enactment of "The New Turkish Commercial Code" (New TCC), which came into existence in July 2012. The main theme for the enactment of this code is corporate governance. Nongovernmental organizations such as Corporate Governance Association of Turkey, Corporate Governance Forum of Turkey and Turkish Industrialists and Businessmen Association (TUSIAD), also play a crucial role in development of corporate governance in Turkey. These frameworks account to an excellent progress in the Turkish corporate governance practice in a relatively short time (Ararat and Orbay 2006; Yüksel 2008; Selekler-Goksen and Oktem 2009).

In Turkey, corporate governance problem is more of ownership concentration and board monitoring independence issues. Family-controlled corporations and group of corporations are some of the main features of Turkish firms visible by their high degree of ownership concentration and cross-ownership between corporations. In Turkey controlling stockholders always play the principal role in the management and strategic direction of the corporations (Yüksel, 2008). Several of the largest corporations in Turkey are interlocked with one another within business groups. These business groups which are organized around a holding company are owned and controlled by a single family or a small number of allied families who maintain them as coherent institutions within which funds, assets, supplies and employees may be transferred as

desired. The most frequent system of maintaining family control business in Turkey is the holding company. The role of the holding company in the Turkish corporate governance is very crucial. They are legally defined as investment corporations with the sole purpose of acquiring the stock of other corporations and managing them.

According to Robertson (2009), 60% of Turkish corporations are owned by individuals or families. The average number of shares that are not held by corporate insiders (free float shares) in Istanbul Stock Exchange is just 20%, and there were very few public corporations with more than 50% free float. She also found that in more than half of the listed companies, CEOs are the majority shareholders; this makes it very tedious to separate governance from management. Turkey has an underdeveloped equity culture; generally, firms that have little reliance on capital markets also have little incentive in the protection of minority shareholders interest (Robertson, 2009). It is a common practice to see members of the owner family on the board of directors and even in the top managerial position of a company (Yurtoğlu, 2000). There are two types of board members other than family members that are common in Turkish corporations, the first are former military officers or politicians, they are given memberships in the boards mainly for public relations purposes and to solidify relationships with important external constituencies. The second category comprises certain professionals who carry out certain limited functions, probably advising in areas of competence and signaling to the outside world that the company is in good hands (Buğra, 1994). Therefore separation of ownership and control, board independence and board ability to fully supervise and control management are the main problems of corporate governance in Turkey. Separation of management and control of decisions contributes to the development of corporations in which the executives do not have a significant stake in the wealth effects of their verdict (Fama and Jensen, 1983).

2.3 Corporate Governance Environment in Nigeria

Corporate governance has experienced various problems and was neglected for a long time, in both government regulation and academia in Nigeria (Ranti, 2011). Every corporation incorporated in Nigeria, whether; private or public liability corporation, listed in Nigerian Stock Exchange or quoted in Nigerian Stock Exchange and International Stock Exchange Markets elsewhere, or not quoted at all is subject to the compliance of the provisions of Companies and Allied Matters Act (CAMA 1990). There are many provisions in this act that set a ground for good corporate governance, these include among others, rights of shareholders, rights and duties of directors, board composition and characteristics, power of the company and also lifting of the veil provisions. Corporate Affairs Commission (CAC) is another regulatory body in Nigeria responsible for

the incorporation of corporations and providing guidelines for the proper operation of the incorporated corporations. Investment and Securities Act (ISA 1999) is also one of the legislations in Nigeria that allows Securities and Exchange Commission (SEC) to regulate the activities of Nigerian listed corporations, the result of these legislation on corporate governance include among others the Code of corporate governance for public companies (2003 and 2011). In addition, every financial corporation in Nigeria is subject to the regulation of Banks and other Financial Institutions Act (BOFIA 1991). BOFIA 1991 gives authority to the Central Bank of Nigeria (CBN) to register and regulate banks and other financial institutions (Ranti, 2011). Since 2011 there have been many regulations and enforcement on corporate governance by the Central Bank of Nigeria. The adaptation of International Financial Reporting Standards in Nigeria is also another effort in trying to enhance effective corporate governance.

Corporate governance faced several problems in Nigeria ranging from massive corporate scandals to inadequate and ineffective legislations. Many banks and corporations collapsed in the 1990s as a result of insufficient regulations to tackle corporate scandals. The ways of business and dealings in Nigeria have amounted to various corporate scandals that deeply effect shareholders and other stakeholders (Sanda et al, 2005). The Nigerian Stock Exchange itself faced a series of problems that hinders it from expanding and controlling the activities of its listed corporations. These problems include liquidity problem, low demand for securities, low trading volume and most importantly a serious delay in the establishment of regulatory body for the market. The Securities and Exchange Commission (SEC) came into existence in 1979, almost twenty years after the establishment of Nigerian Stock Exchange market, and it took another twenty years to enact the Securities and Investment Act (1999). Therefore, Nigerian Stock Exchange functioned for about forty years without a proper governance framework for the discharge of its spontaneous and fiduciary duties (Sanda et al, 2005). According to Ahunwan (2002) another problem that hinders stocks to flow into the Nigerian stock market was the imposition of absolute control over public utilities, infrastructure and social service provision by the Nigerian government through establishing the state owned corporations. Foreign investors, especially British firms have a significant interest to invest in these areas, but the government prohibited foreign ownership. One of the key problems of corporate governance in Nigeria is that; appointment to board of directors, senior management positions and sometimes even lower positions is often based on social/political connections, ethnic and/or religious loyalty rather than efficiency and professional qualifications (Lincoln and Adedoyin, 2012). Therefore it is urged that the Nigerian government should introduce tangible reforms that directly affect corporate governance; these may include strengthening company law,

reforming the legal system to enforce effective shareholders' rights and liberalizing the capital markets.

3. Board Committees and Ownership Structure as Internal Corporate Governance Mechanisms

3.1 Board Committees

In most of the companies, board of directors delegate their role to various board committees. Committees in the board of directors are the roots of pivotal decisions, establishment of committees is a systematic division of responsibilities within the board, and therefore committees are assumed to have a direct relation with corporate financial performance (Kula, 2005). The effectiveness of boards is also a function of the effectiveness of the committees of that board, therefore corporate governance best practices and the legislation in many countries recommend that boards should adopt board committees. According to SEC code (2011) the board of directors can establish additional committees beside Audit Committee such as Governance Committee and Risk Management Committee, Remuneration Committee and others, depending on the needs, size, and industrial requirements of the corporation. According to Turkish Commercial Law, boards can divide and share responsibilities among one or more members or any sub-committee (Art. 319), but the committees are not compulsory (Kula, 2005).

Audit committees are generally regarded as one of the important mechanisms for corporations' corporate governance. According to DeZoort et al (2002) an effective audit committee should ensure reliable financial reporting, internal controls and risk management. Spira (1998) defines audit committee as a subcommittee that mostly consist of non-executive directors whose jobs largely include issues of auditing, internal control and financial reporting. He further stated that the main role of audit committee is to carry out thorough review on behalf of the board, in other to save time and to ensure the skills and knowledge of non-executive directors are effectively utilized.

Audit committees in the board of corporations are very crucial in monitoring activities. Al-Matari et al (2012) examined a sample of 135 Saudi listed corporations and found that Audit Committee size have a significant correlation with firm performance, but Audit Committee Independence and Audit Committee meetings were found to be insignificantly correlated to financial performance. Saibaba and Ansari (2013) studied a sample of 30 BSE Sensex Indian listed corporations, they employed pooled regression analyses method to examine the data for the years 2008-09 and 2010-11, and the results show a positive and significant relationship between Audit Committee and financial measures. Aldamen et al (2012) studied a sample of 120 corporations listed on the S&P 300 from 2008 to 2009, using correlation matrix, regression analyses, sensitivity analyses and robustness test, they found that Audit

Committee positively affect accounting performance and smaller Audit Committees that consist of experienced financial experts are probably related to positive corporate performance. Bouaziz (2012) examined a sample of 26 Tunisian listed corporations with the data of 2007 to 2010, using linear regressions and t-test, it was found that Audit Committee is significantly related to the financial performance of Tunisian corporations. Kyereboah-Coleman (2007) also found a positive and significant relationship between audit committee size and performance.

While Carter et al (2010) studied a sample of corporations in S&P 500 index for a five-year period of 1998–2002, using regression analyses and Hausman Tests of Endogeneity, they found that there is no any significant relationship between board's important committees such as Audit Committee with corporate performance. Wei (2007) and Sunday (2008) also couldn't find any significant relationship between Audit Committee and performance of a corporation.

3.2 Ownership Concentration

Successful corporate governance is subject to the mixture of equity and fairness in the treatment of shareholders, protection of their rights and a superb ownership concentration (Mandacı and Gümüş, 2010). High ownership concentration is the practice of holding high/majority or great amount of shares by few investors. According to La Porta, Lopez-de-Silanes and Shleifer (1999) it is prominent that families, holding companies, and governments are the archetype controllers and investors of corporations in the vast majority of the countries in the world. High ownership concentration is not a prominent practice in UK and USA but it is visible to some extent in Germany and Japan due to the fact that the major shareholders of many corporations in Germany and Japan are commercial banks while in Latin America, Africa, Finland, Italy, Sweden, Turkey and most of Asian countries, families are the major shareholders of corporations (Wei, 2007). Diffuse shareholders partake in corporate governance directly and indirectly, directly by voting on critical issues concerning the corporation, such as change in major business strategies, liquidation, mergers, and indirectly by appointing the board members to represent them and oversee the managerial decisions (Ranti, 2011). Also the privatization of government corporations and foreign ownership of indigenous corporation can increase the performance of a corporation, this is because expatriate shareholders require substantial amount of information disclosures, and ensure a consistence monitoring and supervising mechanisms in the corporation (Boubakri et.al, 2004). According to Ahunwan (2002) widely dispersed structure or diffuse ownership structure in the United States of America is as a result of the minority shareholders protection right that they are practicing, therefore ownership concentration is high in an economy that have a deprived shareholders protection. The proponents of agency theory argued that

high concentration causes major shareholders to prioritize their personal interests which results to agency problem (Mandacı and Gumus, 2010). The key issue in the agency literature is centered on the information asymmetry due to the fact that outside shareholders lack full information about the corporation's performance and operations or reasons for under-performance (Oyejide and Soyibo, 2001). Disperse and well-informed stockholders can be more effective at employing their voting rights compared to shareholders structure that is small and consists of unapprised shareholders (Ranti, 2011). It is generally accepted that a block-holder is a shareholder that holds at least 5% of the corporation's shares (Owtscharov, 2007).

According to Robertson (2009) 60% of the corporations in Turkey are owned by individuals or families. From a sample of 243 corporations listed on Borsa Istanbul in 2006, it was observed that out of 45% of the sampled corporations, in majority of the cases more than 50% of the voting is controlled by one shareholder, and normally the controlling shareholder was either a holding company or controlled by a family such as Sabancı, Koç, Karamahmet, Şahenk or Doğan (World Bank Group, 2006). Therefore ownership is highly concentrated in Turkey. On the other hand, ownership in Nigerian companies was highly concentrated (Ahunwan 2002), it was observed that, on average, between 1995 and 1998 Nigerian government owned 8.1% of the corporations listed on the Nigerian Stock Exchange, the ownership is visible in industries like agriculture (32%), petroleum marketing (17%), building materials (15%), banking and finance (21%), automobile and tires (30%), and insurance (15%) (Oyejide and Soyibo, 2001). Nevertheless the introduction of code of corporate governance for public corporations in 2003 is one of the pillars that help to reduce the ownership concentration level in Nigeria (Society for Corporate Governance Nigeria, 2010). One of the provisions to avoid high ownership concentration and control given by SEC 2011 is that, each board of a listed company should consist of a maximum of two members belonging to the same family as members at the same time (SEC 2011).

Mandacı and Gumus (2010) examine "the effects of ownership concentration and managerial ownership on the profitability and the value of non-financial firms listed on the Istanbul Stock Exchange". They used the sample of 203 corporations tested using multiple regression analysis, their result shows that ownership in Turkey is highly concentrated and ownership concentration have a positive and crucial impact on profitability as a measure of financial performance and corporation's value, they also found that managerial ownership in Turkey have a significant negative relation to corporation's value. Leng (2004) studied on a sample of 77 Malaysian listed corporations for a period starting from 1996 to 1999, using both cross-sectional, time-series and panel data regression

methods, it was found that increase in the strength of institutional shareholders have a positive impact on corporation's earnings. Wei (2007) also found that when there is small proportion of state-ownership in a corporation's share, there is no negative correlation with performance, but when the proportion is high, say above 50% the state-ownership becomes negative and crucially effect performance, and little non-state ownership also have a significant positive impact on corporate performance. Boubakri et al, (2005) used a sample of 230 corporations headquartered in 32 developing countries from 1980 to 1997, using multivariate regression analysis, they found that when government relinquishes control of corporations shareholding, it improves profitability, efficiency gains and amounts to increase in output, and they also found that in countries where stock markets are more developed and property rights are protected and enforced, there is always higher improvements in efficiency for corporations. Sanda et.al (2005) also found that director's shareholding is negatively correlated to corporate performance.

While Ranti (2011) found in his research that, a strong and significant positive correlation exists between directors' shareholding and corporate performance. Filatotchev et.al (2005) found that family control is not related to accounting performance measures, institutional shareholding whether foreign or domestic is correlated with positive performance. Berger et al (2005) used regression analyses to test the data of Argentinean banks in the 1990s, the results shows that state-owned banks have poor long-term performance, and the banks that undergone privatization had poor performance at the time of the privatization, but after the privatization the banks dramatically improved. Owtscharov (2007) researched on a sample of 122 domestic public corporations that are listed on the German stock exchange using the data from 1998 to 2003, using OLS he found that there exists no relationship between ownership dispersion and performance of corporations; nevertheless, institutional shareholding is significantly related to firm performance.

4. Methodology

4.1 Research Goal and the Theoretical Model

This study examined the effect of ownership concentration (block holding) and the presence of board committees in the board of directors on the financial performance Turkish and Nigerian listed corporations. In addition, the study also aimed at comparing the presence of board committees and ownership structure between Turkish and Nigerian listed corporations. It is proposed that presence of board committees have a positive effect, whereas concentrated ownership (block holdings) has a negative effect on organizational performance. In addition, it is also

proposed that the companies listed in Borsa İstanbul and Nigerian Stock Exchange differ from each other in terms of presence of board committees.

4.2 Sample and Data Collection

Data was collected through the websites of the companies whose shares are publicly-traded in Borsa İstanbul and Nigerian Stock Exchange. The sample consists of randomly selected 120 Turkish and 94 Nigerian companies, which their shares are traded in 2012. Therefore the total sample used in this study is 214 companies. The data were retrieved from the annual reports and financial statements of the sampled corporations. After the collection of the data, the variables were coded and analyzed using SPSS. For the board committee, three variables were generated. The first is the number of directors in the audit committee of the board of a corporation. The second variable is a dummy variable represented by 1 if there is a corporate governance committee in the board of a corporation and 0 for otherwise. The third variable is also a dummy variable represented by 1 if there is risk management committee in the board of a corporation and 0 for otherwise. On the other hand, the ownership concentration (Block Holding) of the corporations is defined as the percentage of shares held by the first top 10 shareholders of a corporation. In this research, Return on Equity (ROE) which is one of the accounting measures is used to measure organizational performance. ROE is historical in nature and it is developed for reporting purposes, hence it constitute background and inward looking features, represent previous and present management, and board success in utilization and monitoring of corporate resources, therefore it is the traditional measures of corporate performance. Linear regression analyses and t-test were used to analyze the data.

The descriptive statistics of board committee variables are summarized in Table-1.

According to descriptive results, it is observed that there are some corporations that do not have audit committee in the sample. The maximum number of the directors in a single audit committee is 10 and the average is four directors in a committee. The corporations listed in the Nigerian Stock Exchange have a maximum of 10 directors in audit committee and average number of 6 directors. 70.2% of the corporations have six audit committee members, 24.5% have less than six members, 5.3% of the Nigerian listed corporations have audit committee that comprises of more than seven to ten members and only one corporation does not have audit committee. The maximum number of audit committee members in Turkish listed corporations is five, while the average number of directors in the audit committee is two directors. The standard deviation is 0.458 due to the fact that 93.3% of the corporations have two audit committee members, three corporations do not have audit

committee in their boards and 4.2% of the corporations have three to five audit committee members.

Table 1: Descriptive Characteristics of the Sample

Audit Committee	Minimum	Maximum	Mean	Std. Deviation
Turkey	0	5	2.0	0.458
Nigeria	0	10	5.6	1.115
Total	0	10	3.6	1.980
Corporate Governance		Risk Management		
	Yes	No	Yes	No
Turkey	114	6	59	61
Nigeria	40	54	61	33
Total	154	60	120	94

According to the findings, only 42.6% of Nigerian listed corporations have corporate governance committee in their boards while 95% of Turkish corporations have corporate governance committee in their boards. The possible explanation of the differences is associated to the high recommendation of CMB for the establishment of corporate governance committee in Turkish listed corporations' boards. On the other hand, 64.9% of Nigerian listed corporations have risk management committee in their boards and whereas only 49.2% for the corporations listed in Borsa Istanbul. This is because it is highly recommended by CBN that all financial services corporations should have a risks management committee.

Table-2 below shows the level of block holdings in the two stock markets. The minimum shareholding by the top 10 shareholders of the sampled listed corporations in Nigeria is 1.57% of the total share of one corporation, while the maximum is a situation where the whole shares are wholly owned by less than 10 shareholders. It was observed that in 55.3% of the sampled Nigerian corporations, the top 10 shareholders own 50 to 90 percent of the total corporation's share. In addition, in 36.2% of the sampled Nigerian corporations, the top 10 shareholders own less than 50% of the total shareholdings, while the top 10 shareholders of 8.5% of the sampled Nigerian listed corporations own more than 90% of the shares of their corporations. The average shares that the top 10 shareholders of the sampled Nigerian corporations hold are 58.86% of a total corporation's shareholding. The table also shows that the minimum family shareholding in the sampled Turkish corporations is 8.05% of a corporation's total share and the maximum is a situation where one family

own 99% of the total shareholding of the corporation. It was observed that in 45% of the sample; one family holds 50 to 90% of a corporation's total shareholdings and in 7.5% of the Turkish sample corporations one family hold more than 90% of the total shareholdings of their corporation. According to Table-2, the average amount of family shareholding in the sampled Turkish corporations is 55.30% of a total shareholding of a corporation.

Table 2: Ownership Concentration

Countries	N	Minimum	Maximum	Mean	Std.
Nigeria	94	1.57	100	58.862	23.468
Turkey	120	8.05	99.28	55.309	22.060
Total	214	1.57	100	56.869	22.704

4.3 Data Analysis and Findings

The t-test for country differences shows significant differences between the number of directors in the audit committee of the sampled corporations from the two countries at a significant level ($p < 0.01$) (Table-3). On average, audit committee in Nigerian boards consists of six directors while on average there are two directors in the audit committee of the Turkish corporations. This is because it was recommended by SEC (2011) that the statutory audit committee in Nigeria should consist of not more than six directors, while in Turkey there is no such recommendation.

Table 3: The Difference of Board Committees between Nigeria and Turkey

Group Statistics	Country	N	Mean	Std. Deviation	Mean Difference	T	Sig. (2-tailed)
Audit Committee	Nigeria	94	5.64	1.115	-3.630	-32.350	0.000
	Turkey	120	2.01	0.458			
Corporate Governance Committee	Nigeria	94	0.42	0.496	0.531	10.480	0.00
	Turkey	120	0.95	0.219			
Risk Management Committee	Nigeria	94	0.65	0.480	-0.124	1.621	0.10
	Turkey	120	0.53	0.608			

From Table 3, it can be observed that there is a significant difference ($p < 0.01$) in the existence of corporate governance committee between the two countries. 95% of the corporations listed in Borsa Istanbul according to this sample have corporate governance committee in their boards. Only 45% of the sampled listed Nigerian corporations have corporate governance committee in their board of directors. Furthermore, there exists no significant distinction in the existence of risk management committee in the board of the total sampled corporations. Only 65% of the Nigerian listed corporations have risk management committee and most of the corporations that have the committee are financial services corporations. On the other hand, only 53% of the Turkish sampled corporations have risk management committee in their boards.

In addition, there is no statistically significant differences in block holdings of company shares between Nigeria and Turkey (Table-4). In both countries, ownership concentration is high.

Table 4: Ownership Concentration Differences

Group Statistics	Country	N	Mean	Std. Deviation	Mean Difference	t	Sig. (2-tailed)
Block Holdings	Nigeria	94	58.86	23.468	-3.553	-1.137	0.25
	Turkey	120	55.31	22.661			

Table 5: Total Effect of Board Committees and Block Holdings on Return on Equity

Model I: Total Sample	Unstandardized Coefficients		Standardized Coefficients	T	Sig.
	B	Std. Error	Beta		
Constant	-1.573	.926		-1.699	.093
Audit Committee	.152	.118	.150	1.283	.203
Governance	.441	.258	.193	1.71	.090

Committee				3	*
Risk Committee	-	.277	-.234	-	.050
	.552			1.99	**
				1	
Block Holdings	.004	.006	.083	.720	.473

R Square 0.052

Model II:	Unstandardized Coefficients		Standardized Coefficients	T	Sig.
	B	Std. Error	Beta		
Turkish Sample					
Constant	.020	.047		.428	.669
Audit Committee	.139	.050	.275	2.766	.007*
Governance Committee	-	.117	-.321	-	.004**
	.340			2.906	
Risk Committee	.020	.037	.053	.548	.585
Block Holdings	-	.001	-.052	-	.583
	.001			.551	

R Square 0.053

Model:	Unstandardized Coefficients		Standardized Coefficients	t	Sig.
	B	Std. Error	Beta		
Nigerian Sample					
Constant	-	.926		-	.093
	1.573			1.699	
Audit Committee	.152	.118	.150	1.283	.203
Governance	.441	.258	.193	1.71	.090

Committee				3	*
Risk Committee	-	.277	-.234	-	.050
	.552			1.99	**
				1	
Block Holdings	.004	.006	.083	.720	.473

R Square 0.102

Dependent Variable: ROE *significant at the level of 10%

**significant at the level of 5%

Table 5 above shows the general effect of the mechanisms on ROE of the total sampled corporations. The result shows that corporate governance committee is positively and significantly related to ROE of the total sampled corporations, while risk management committee is negatively related to ROE at 5% significant levels.

In Turkey, according to the findings demonstrated in Table 5, number of directors in audit committee is positive and significantly related to ROE. Therefore, presence of audit committees in the boards of corporations has significant effect on their financial performance. The result also shows that corporate governance committee has a significantly negative relationship with ROE. It is shown in the descriptive analyses that 95% of the sampled Turkish corporations have a corporate governance committee, however agency cost of maintaining the committee may influence the ROE of the corporations if the results obtained from the committee is not worth the cost of establishing and maintaining the committee in the boards of the corporations. Similarly, block holdings has an insignificant negative relationship with ROE.

In the Nigerian sampled corporations, it is shown in Table 5 that corporate governance committee also has a direct and significant relationship with ROE at 10% level. On the contrary, risk management committee has a significant negative relationship with ROE at a 5% significance level.

5. Conclusion

Various research on the effect of internal corporate governance mechanisms such as board committees and ownership concentration have been primarily focused on western countries and western models. However, corporations in different environments have different cultures, legal and institutional bodies which significantly influence corporate governance-performance relationship. Therefore, it is important to test the applicability of the Anglo-American model in different environments (Filatotchev et al, 2005). With this research, it is aimed to fill this gap by concentrating on the application of corporate governance internal

mechanisms such as board committees and ownership concentration in Turkey and Nigeria.

Research results indicate that number of directors in audit committee is found to have positive and insignificant relation with performance of the general sample and the Nigerian sampled corporations. These findings are in line with the findings of Leng (2004) and Sunday (2008). On the other hand it is also found that number of directors in audit committee have a positive and significant effect on the ROE of the sampled Turkish corporations, this result is in line with the findings of Kyereboah-Coleman (2007). There is also a considerable significant difference on the number of directors in audit committee of the boards of the Nigerian and Turkish corporations. On average there are six directors in the audit committee of the sampled Nigerian corporations while there are only two directors that are in the audit committee of an average Turkish sampled corporation. In either way, audit committee is positively related to performance.

Corporate governance committee was found to have a positive and significant relationship with the performance of the general sampled listed corporations. This is an additional prove of all the research and the theories that suggested or found that corporate governance improve performance. ROE of the sampled Nigerian corporations also reports a positive and significant relation with corporate governance committee of the boards of the sampled corporations. It was found that there is a negative but insignificant relationship between corporate governance committee and the financial performance of the sampled Turkish Listed corporations. Also, there is a significant difference in the boards of the two countries regarding the establishment of this committee. Although the Turkish corporations have more corporate governance committee in their boards, yet negative relationship was found regarding the committee and performance. This result shows that; as important as corporate governace committee is in an organization, other factors such as environmental and political factors also play a significant role in corporate governance in different geographical settings. This also confirms the statement of Ararat and Orbay (2006) which stated that individual distinctive economic, political and environmental factors such as the depth and liquidity of securities markets, the quality of laws, the level of enforcement, disclosure infrastructure, the quality of banking system and culture play a significant role in setting the quality of corporate governance of corporations.

Risk committee is also found to have a positive but minor relationship with the general sample and the Turkish sampled listed corporations, this is in line with the findings of Salin and Rahman (2012), while for the Nigerian listed corporations, a significant negative relationship was found between the presence of risk committee and ROE. There is no significant

difference between Nigerian corporations and Turkish corporations for the presence of risk committee.

This research found a positive but insignificant relationship between block holding and the performance of the general sampled corporations. The result is the same in the Nigerian sampled corporations. It is also found that the result of the Turkish sampled corporations is insignificantly related to corporations' financial performance, ROE is negatively related to block holdings. These findings are closely related to the findings of Filatotchev et.al (2005) and Owtscharov (2007). No significant differences were found in terms of ownership concentration and financial performance of the corporations. This shows that ownership concentration does not matter much on the performance of corporations.

Although the findings of this research are limited to the sample size, the results suggest important implications. This study provided a basic understanding of Turkish and Nigerian corporations in terms of board committees and ownership structure. The main limitation of this study is the sample size, future studies could address the topic by enlarging the sample to include all of the publicly-traded companies in Turkey and in Nigeria. Furthermore, comparisons between the two countries could be done by considering different time frames. In addition, future studies could also compare other board dimensions and organizational performance relation between Turkey and Nigeria.

References

- Aldamen, H. et al. (2012). Audit committee characteristics and firm performance during the global financial crisis' *Accounting & Finance*, 52, 971-1000.
- Al-Matari, et al. (2012). Board of Directors, Audit Committee Characteristics and Performance of Saudi Arabia Listed Companies. *International Review of Management and Marketing Vol. 2*, No. 4 2146-4405
- DeZoort, F.T., Hermanson, D.R., Archambeault, D. S. and Reed, S.A. (2002). Audit Committee Effectiveness: A Synthesis of the Empirical Audit Committee Literature. *Journal of Accounting Literature*, 21: 38-75.
- Andres, D. P., Azofra, V. and Lopez, F. (2005). Corporate Boards in OECD Countries: size, composition, functioning and effectiveness. *Corporate Governance Volume 13*(2)
- Ahunwan, B. (2002). Corporate Governance in Nigeria. *Journal of Business Ethics* 37:269–287.

- Ararat, M. and Orbay, H. (2006). *Corporate Governance in Turkey; Implications for investments and growth*. Background Paper for Turkey's Investment Climate Assessment 2006.
- Berger, A.N, et al. (2005). Corporate governance and bank performance: A joint analysis of the static, selection, and dynamic effects of domestic, foreign, and state ownership. *Journal of Banking & Finance* 29 2179–2221.
- Bouaziz, Z. (2012). The Impact of the Presence of Audit Committees on the Financial Performance of Tunisian Companies. *International Journal of Management & Business Studies* Vol. 2, (4) 2230-9519.
- Boubakri, N., Cosset, J. and Guedhami, O. (2005). Liberalization, corporate governance and the performance of privatized firms in developing countries. *Journal of Corporate Finance*, 11 767– 790.
- Buğra, A. (1994) *State and Business in Modern Turkey*, State University of New York Press.
- Carter D.A, et al (2010). The Gender and Ethnic Diversity of US Boards and Board Committees and Firm Financial Performance. *Corporate Governance: An International Review*, 18(5): 396–414.
- Dang R, Nguyen D.K, and Vo L.C (2012). Women on Corporate Boards and Firm Performance: A Comparative Study. *JEL classification codes: G30; G34; J16*.
- Fama, E. F. & Jensen, M. C. (1983). Separation of ownership and control. *Journal of Law and Economics*, 26, 301–325.
- Filatotchev, I., Lien, Y. and Piesse, J. (2005). Corporate Governance and Performance in Publicly Listed, Family-Controlled Firms: Evidence from Taiwan. *Asia Pacific Journal of Management*, 22, 257–283.
- Kyereboah-Coleman A (2007) *Relationship Between Corporate Governance and Firm Performance: An African Perspective*. Ph.D. Thesis, University of Stellenbosch.
- Kula, V. (2005). The Impact of the Roles, Structure and Process of Boards on Firm Performance: evidence from Turkey. *Corporate Governance*, Volume 13 Number 2.
- La Porta, R., Lopez-De-Silanes, F. and Shleifer, A. (1999). Corporate ownership around the world. *Journal of Finance*, 54: 471–514.
- Leng, A.C.A (2004). The Impact of Corporate Governance Practices on Firms' Financial Performance Evidence from Malaysian Companies. *ASEAN Economic Bulletin Vol. 21, No. (3) 0217-4472*.

- Lincoln, A. and Adedoyin, O. (2012). Corporate Governance and Gender Diversity in Nigerian Boardrooms. *International Journal of Social, Human Science and Engineering* Vol: 6 No:11.
- Mandaci, P. E. & Gumus, K. G. (2010). Ownership Concentration, Managerial Ownership and Firm Performance: Evidence from Turkey. *SEE Journal* DOI: 10.2478/v10033-010-0005-4.
- Ogbechie, C. I. (2012) *Key Determinants of Effective Boards of Directors - Evidence from Nigeria*. Ph.D. Thesis, Brunel University.
- Owtscharov, A. (2007). *The German system of finance and corporate governance: Gateways to change and implications for firm performance*. Ph.D. Thesis, University of St. Gallen.
- Oyejide, T. A. and Soyibo, A. (2001). Corporate Governance In Nigeria,. Paper Presented at the Conference on Corporate Governance, Accra, Ghana.
- Ranti, U. O. (2011) 'Corporate Governance and Financial Performance of Banks: A Study of Listed Banks in Nigeria' Ph.D. Thesis, Covenant University.
- Robertson, D. C. (2009), Corporate Social Responsibility and Different Stages of Economic Development: Singapore, Turkey, and Ethiopia. *Journal of Business Ethics* 88: 617–633.
- Saibaba, M.D and Ansari, V.A (2013). Audit Committees, Board Structures and Firm Performance: A Panel Data Study of BSE 30 Companies. *Journal of Accounting Research & Audit Practices, Vol. XII, No. 2*.
- Sanda, A., Mikailu, A. and Garba, T. (2005). Corporate governance mechanisms and firm financial performance in Nigeria. *African Economic Research Consortium*.
- Selekler-Goksen, N. N. and Oktem, O. Y. (2009). Countervailing institutional forces: corporate governance in Turkish family business groups *Journal of Management Governance* 13:193–213.
- Sunday, O. K. (2008). Corporate Governance and Firm Performance: The Case of Nigerian Listed Firms. *European Journal of Economics, Finance and Administrative Sciences* 1450-2275.
- Wei, G. (2007). Ownership Structure, Corporate Governance and Company Performance in China. *Asia Pacific Business Review* 13(4) 519–545.
- Yurtoğlu, B.B. (2000). Ownership, Control and Performance of Turkish Listed Firms, *Empirica*, 27: 193–222.
- Yüksel, C., (2008). Recent Developments of Corporate Governance in the Global Economy and the New Turkish Commercial Draft Law Reforms.

Journal of International Commercial Law and Technology, 3(2): 101–111.

FOREIGN DIRECTORS IN THE BOARDROOM AND FINANCIAL PERFORMANCE OF LISTED DEPOSIT MONEY BANKS IN NIGERIA

by

*Salami Suleiman (B.Sc., M.Sc., ACA)
Assistant Lecturer, Department of Accounting
Ahmadu Bello University, Zaria, Nigeria.
+2348053329132
+2347036425085
Suleiman_salami@yahoo.com*

&

*Ramlat Muhammed Oche (B.Sc.)
Graduate Student
Department of Business Administration
Ahmadu Bello University, Zaria, Nigeria
+2348072556453
mohammedramlah@gmail.com*

ABSTRACT

Empirical evidence on the relationship between foreign directors and financial performance in Nigeria is scanty. This study examines the impact of foreign directors in the boardroom on the financial performance of listed deposit money banks in Nigeria. Foreign directors is proxied as the ratio of female directors to the total number of directors and a market based measure, Tobin's Q was used to proxy performance. Data for the study were sourced from the Nigerian Stock Exchange Fact book and the banks' annual report for the period 2009-2012. Multiple regression was used with the aid of Stata 10.1 as our tool of analysis in testing our hypotheses. Controlling for board size and firm size, our findings reveal that foreign directors have a negative significant impact on the performance of DMBs in Nigeria. We therefore recommend that deposit money banks of listed deposit money banks in Nigeria should ensure better involvement of foreign directors in activities of the board so as to improve performance.

Key words: Board of Directors , foreign directors and Performance

ABSTRACT

Empirical evidence on the relationship between foreign directors and financial performance in Nigeria is scanty. This study examines the impact of foreign directors in the boardroom on the financial performance of listed deposit money banks in Nigeria. Foreign directors is proxied as the ratio of female directors to the total number of directors and a market based measure, Tobin's Q was used to proxy performance. Data for the study were sourced from the Nigerian Stock Exchange Fact book and the banks' annual report for the period 2009-2012. Multiple regression was used with the aid of Stata 10.1 as our tool of analysis in testing our hypotheses. Controlling for board size and firm size, our findings reveal that foreign directors have a negative significant impact on the performance of DMBs in Nigeria. We therefore recommend that deposit money banks of listed deposit money banks in Nigeria should ensure better involvement of foreign directors in activities of the board so as to improve performance.

Key words: Board of Directors , foreign directors and Performance

1.0 Introduction

Corporate governance has been an area of interest to practitioners and academia in relation to the operations of companies especially banks in Nigeria. Of recent is the case of oceanic bank where this CEO has been brought to book in relation to corrupt practices.

Board of directors is the tool through which management of firms are monitored for improved performance. This improved performance identified in the annual reports and accounts send signal to participants in the stock market participants. Therefore, the market value or net worth of the firms are expected to increase or decrease based on the information in the published annual reports and accounts.

Composition of the board of directors can be argued as a means through which the firms' performance will be positively or negatively affected. Apart from the indigenous directors on the boards of Nigerian banks, foreigners can be found at least in position of a non executive director or independent director.

The role of foreigners on the board has received little interest in the recent studies as regards resolving agency problem. That is, there are various questions that can be asked as regards the role of foreigners on the board.

Proponent of board diversity argues that a more diverse board brainstorms and makes good decision which leads to creativity and innovation. On the other hand, the opposing party to diversity argues that diversity slows decision making due to conflict among members; board members find it difficult to hold board meeting due to lack of coordination and non commitment from members of the board.

This paper focuses on the economic role of foreigners on the boards of Nigerian deposit money banks. We seek to investigate whether the presence of foreigners will positively impact on the activities of the board, thereby improving performance.

The hypothesis of this study is

H₀₁: There exist no significant relationship between foreign directors on the board and performance of Nigeria DMBs

2.0 Literature Review and Theoretical Framework

Foreign directors are defined as the number of non Nigerians on the board of Nigerian banks. This could also be seen as the ratio of minority directors to the total number of directors.

Apart from little empirical work on the relationship between foreign directors and performance most of which are from developed countries, findings from the studies are conflicting. This study therefore seeks to contribute to existing empirical work in the area of board diversity and performance of firms.

Darmadi (2011) carried out a cross sectional study to examine whether diversity of corporate board enhances performance in Indonesia listed companies. The results show a negative relationship between nationality and corporate financial performance. Also, female top executives is negatively related to both accounting and market performance, highlighting that female executive is not associated with improved level of performance. The study also found that smaller firms which are mostly family dominated tend to have a higher percentage of women in their board implying that large firms are usually tough for women to occupy position on their boards. However, their timeframe is limited to one year.

Garba and Abubakar (2014) examined the effect of corporate board diversity on financial performance of twelve listed insurance firms for the period 2004-2009 in Nigeria. Applying Feasible Generalized Least Squares (FGLS) and random effects and Return on asset, Return on equity, and Tobin's Q as his dependent variables, their study found out that the inclusion of foreign directors on the board have a positive effect on the performance of listed insurance firms. They also found a negative relationship between ethnic diversity and financial performance of insurance firms. That is the inclusion of a southerner or northerner into corporate boards reduces financial performance of insurance companies. However, out of twenty nine insurance firms listed on the fact book of the NSE the study utilized only twelve listed firms which is less than average of the total firms.

One of the theoretical arguments in favour of foreign nationals on the board of banks is the human capital theory as opined by Becker in 1964. In line with the human capital theory, an individual's stock of education, experience and skills will assist the firm in achieving competitive advantage thereby improving financial performance. Therefore foreign nationals on the boards of banks will have a positive relationship with performance.

However, the relationship between foreign directors and performance could also be negative. Tokenism as explained by Kanter (1977) shows that representations lower than 15% in any group may lead to

underperformance. Given that the representation of foreigners on the board of Nigerian banks is low or nil some banks like First bank, this may negatively affect their overall contribution . therefore this will lead to a negative relationship between foreign directors and performance.

3.0 METHODOLOGY

This study uses a descriptive and correctional research design using panel data. We utilise annual reports and accounts of listed deposit money banks and the Nigerian stock exchange fact book. The population of this study is all twenty one banks listed on the Nigerian stock exchange fact book for the period 2009- 2013. Banks not listed on the Nigeria Stock Exchange prior to January 2009 were eliminated. Also banks that changed their names between 2009 and 2012 were filtered out. Therefore, we used a total number of twelve banks.

The study covers a period of four years i.e. 2009-2012 both years inclusive. This period was chosen due to (1) this was the period when the prices of stock got balanced after the stock price crash in Nigeria (Mohammed, 2010 as cited in Sambo, 2014), and (2) focusing on a period coinciding with financial crisis could have affected both the boards' efforts and the firm performance (Ararat, Aksu and Cetin 2010).

Variables utilised in this study is defined below:

Table 1: Variables definition
Measurement

Variables	Measurement
Tobin's Q	Tobin's Q is the ratio of market value to its book value of assets. Where market value equals market value of equity plus liabilities divided by book value of assets (Adams et. al. 2008)
FORD	In line with Garba et. al. (2014), Foreign diversity is measured as the ratio of foreign directors on the board to the total number of directors.
Board Size	Is measured as Log of total board size (Carter et.al. 2002)
Firm Size	Is measured as Log of total assets

Model Specification

In estimating the set of relationship between gender diversity and financial performance, we use a multiple linear regression analysis. This study expresses financial performance as a function of gender diversity in the board room:

$$\text{FP (FD)} \dots \dots \dots \text{EQ 1}$$

Incorporating our measure of financial performance and gender diversity into eq1, we arrive at:

$$\text{Tobin's Q} \dots \dots \dots \text{EQ 2}$$

Incorporating our control variables into eq 2 above, we arrive at:

$$\text{Tobin's Q} \dots \dots \dots \text{EQ 3}$$

Transforming the above into linear relation, we arrive at:

$$\text{Tobin's Q}_{it} = \alpha_0 + \beta_1 \text{FD}_{it} + \beta_2 \text{LBS}_{it} + \beta_3 \text{LFS}_{it} + \mu_{it} \dots \dots \dots \text{EQ 4}$$

Where:

Tobin's Q = representing financial performance

α_0 = the intercept

FD = percentage of foreign directors to the total number of directors

LBS = log of board size

LFS = log of firm size

β_1 to β_3 = parameters to be estimated

μ_i = error term

4.0 RESULTS AND DISCUSSION

This table shows the result of our regression of the model relating foreign diversity and performance. It follows with analysis and deductions from the result.

Table 2: Regression results

Fixed effect regression model				Random Effect Regression Model		
Statistics variables	Beta coefficients	T.Value s	Sig	Beta coefficients	Z.Valu es	Sig
FD	-.5770399	-1.73	0.093	-.128626	-0.55	0.581
LBS	-.6672928	-2.39	0.023	-.9451002	-3.33	0.001
LFS	-.4943016	-4.59	0.00	-.270256	-2.67	0.008
R-Square			0.6506			0.2116
F.V/WaldC h			20.49			37.97
Sig			0.00			0.00

Source: STATA Output Result

The table above shows the result of fixed and random effect regression using Stata 10.1. However the result of the hausman specification test (see appendix) indicate that the result of the fixed effects GLS regression is more appropriate for interpreting the result. Therefore our deduction from the above the result will be based on fixed effects regression.

Contrary to our expectation, the percentage of foreign directors is negatively related to financial performance. This result is significant at 10% level of significance. Therefore we reject our hypotheses for this study which states that foreign directors on the board does not significantly affect financial performance of listed deposit money banks in Nigeria. This means that as foreigners increase on the board of Nigerian deposit money banks, financial performance will decrease by 0.3333. This contradicts the findings of Garba et al (2014) and is consistent with that of Darmadi (2011).

As regards our control variables, the results is consistent with our apriori expectation. Board size has a negative relationship with firm performance. the result is significant at 1%. That is as board size increases, performance of listed deposit money banks tends to decrease by 2.39 also firm size shows a negative relationship with firm performance. Similar with board size, the P-Value is significant at 1%. That means, firm size

neactively impact on performance of listed deposit money banks in Nigeria. That is, capital is not adequately utilised in the operations.

The explanatory power of our regressor in predicting financial performance is 65%. that is, foreign diversity in the boardroom taking into consideration board size and firm size influences financial performance up to 65%. The overall fitness of the model depicted by Wald Chi is 20.49 which itself is significant at 1%

ADDITIONAL ANALYSIS/ ROBUSTNESS OF RESULT

In other to ensure that our results is not driven by measurement error, we re-run our results after re- measuring our independent variable. We proxy foreign directors on the board as a dummy variable which equals to one if there is a foreign director on the board otherwise zero. Our results remain the same as the coefficient for foreign directors on the board becomes more negatively significant. The results is shown below:

Table 3: Regression results

Fixed effect regression model				Random Effect Regression Model		
Statistics variables	Beta coefficients	T.Value s	Sig	Beta coefficients	Z.Valu es	Sig
FDD	-.1611958	-2.06	0.048	.1224484	-1.92	0.054
LBS	-.7469735	-2.74	0.010	-.8905583	-3.38	0.001
LFS	-.461191	-4.47	0.00	-.331206	-3.57	0.000
R-Square			0.6623			0.2277
F.V/WaldC h			21.57			51.4
Sig			0.00			0.00

Source: STATA Output Result

CONCLUSION AND RECOMMENDATION

We provide evidence which shows that foreign directors in the board room contributes negatively to financial performance of listed deposit money banks. This result is obtained controlling for board size and firm size of these banks. We contribute to existing literature on business case for the inclusion of foreigners in the boardroom. Our findings should be taken with caution as we focus on only on listed deposit money banks. Other financial firms like insurance companies are excluded. Also non financial firms are not included within the scope of this study. Future research should explore these gaps.

References

- Adams, R.B. & Ferreira, D. (2008). Women in the boardroom and their impact on governance and performance. *Journal of Financial Economics*. Forthcoming.
- Anderson, R.C., Reeb, D. M., Upadhyay, A. & Zhao, W. (2009). The economics of director heterogeneity. fox school of business, Temple University, Philadelphia, USA
- Becker, G. (1964). *Human Capital*, Chicago IL : University of Chicago Press
- Bjorklund, R.L. (2010). corporate board governance and the diversity participation paradox-A note on the banking sector. *International Journal of Public Information Systems*. vol 2010:1
- Broome, L.L., Conley, J. M., & Krawiec, K.D. (2011). Dangerous Categories: Narratives of corporate board diversity. Electronic copy available at <http://ssrn.com/abstract=1679775>
- Carter, D., A. D'souza, F., Simkins, B. J., & Simpson, W., G. (2002). Corporate Governance, Board Diversity and Firm Value. *College of Business Administration, Oklahoma State University, Stillwater, OK 74078-4011, USA*
- Carter, D., A. D'souza, F., Simkins, B. J., & Simpson, W., G. (2007). The diversity of corporate board committees and firm financial performance. Electronic copy available at <http://ssrn.com/abstract=780910>
- Carter, D., A. D'souza, F., Simkins, B. J., & Simpson, W., G. (2010). The gender and ethnic diversity of US boards and board committees and firm financial performance. *Corporate governance: An international review* 18(5): 396-414.
- Chandrasekharan C.V. (2010). Analysis of Corporate Governance Mechanisms and Non Performing Loans: Evidence from Money Deposit Banks in Nigeria.
- Darmadi. S. (2011). Board diversity and firm performance: The Indonesian evidence. *Forthcoming in the Journal of Corporate Ownership and Control* Vol 18

- Erhardt, N.L., Werbel, J. D., & Shrader, C.B. (2003). Board of director diversity and firm financial performance. *Corporate Governance: An International Review*, vol. 11 No 2, pp 102-111
- Fogelberg, L., and Griffith, J.M., (2000). Control and Bank Performance. *Journal of Financial and Strategic Decisions*, Volume 13 Number 3.
- Francoeur, C., Labelle, R., & Desgagne, B.S. (2008). Gender diversity in corporate government and top management. *Journal of Business Ethics* 81:83-95.
- Garba, T., & Abubakar, B. A. (2014). Corporate board diversity and financial performance of insurance companies in Nigeria: An application of panel data approach. *Asian Economic and Financial Review*.4(2),257-277
- Grund, C., & Nielsen, N. W. (2005). Age structure of the workforce and firm performance. Institute for the study of labour. Discussion paper No 1816. Bonn, Germany.
- Kanter, R. M. (1977). Men and women of the corporation. New York: Basic Books.
- Krishnan, H.A. (2009). What causes turnover among women on top management teams? *Journal of business Research* (62) 1181-1186.
- Mohamad, N.R., Abdullah, S.N., Mokhtar, M.Z. & Kamil, N.F.N. (2009). The effects of board independence, board diversity and corporate social responsibility on earnings management. *Faculty of Management Economics, University of Malaysia*.
- Padilla, L. (2011). The impact of director heterogeneity on corporate restructuring patterns: Beyond Insider/outsider duality. *Troyes champagne school of management*.
- Rose, C. (2007). Does female board representation influence firm performance? The Danish Evidence. *Corporate Governance: An International Review*, 15: 404-413
- Sambo, H. S. (2014). Empirical analysis of investment of performance of selected pension fund administrators in Nigeria. Unpublished seminar paper. *Ahmadu Bello University*.

Sanda, .A.U, Mikailu A.S.& Garba .T (2004). "Director Shareholding, Board Size and Firm Performance of Firms in Nigerian Stock Exchange". *Nigerian Journal of Accounting Research*, Department of Accounting, Ahmadu Bello University, Zaria. Vol1,Number 1, June2004.

Sealy, R., Doldor, E., & Vinnicombe, S. (2009).Increasing diversity on public and private sector boards.Cranfield school of management.

Shittu I. (2010). Managerial Shareholding and Performance of Quoted Nigerian Banks. *Nigerian Journal of accounting research*, ABU Zaria volume 6, number 2.

Smith, N., Smith, V., & Verner, M. (2005). Do women in top management affect firm performance? A discussion paper available at <http://ssrn.com/abstract=780910>.

Terjesen, S., Sealy, R., & Singh, V. (2009).Women directors on corporate boards: A review and research agenda.*Corporate Governance: An International Review*,320-33

regress tq fd lbs lfs

Source	SS	df	MS	Number of obs =	48
-----+-----				F(3, 44) =	6.46
Model	.547331402	3	.182443801	Prob > F	= 0.0010
Residual	1.24234801	44	.028235182	R-squared	=
-----+-----				Adj R-squared =	0.2585
Total	1.78967941	47	.038078285	Root MSE	=
-----+-----					
tq	Coef.	Std. Err.	t	P> t	[95% Conf. Interval]

```

-----+-----
      fd | .2489249 .1809565  1.38  0.176  -.1157689
.6136187
      lbs | -1.137238 .3041747  -3.74  0.001  -1.750262  -
.5242144
      lfs | .0058434 .0933197  0.06  0.950  -.1822301  .193917
      _cons | 2.253397  1.034099  2.18  0.035  .169307
4.337488
-----

```

```
. xtreg tq fd lbs lfs, fe
```

```
Fixed-effects (within) regression          Number of obs   =    48
```

```
Group variable: id                        Number of groups =    12
```

```
R-sq:  within = 0.6506                    Obs per group:  min =    4
```

```
        between = 0.0605                    avg =    4.0
```

```
        overall = 0.0992                    max =    4
```

```
F(3,33) = 20.49
```

```
corr(u_i, Xb) = -0.5630                    Prob > F = 0.0000
```

```
-----+-----
      tq |   Coef.  Std. Err.   t  P>|t|   [95% Conf. Interval]
-----+-----

```

```
      fd | -.5770399 .3338806  -1.73  0.093  -1.256325
.1022454
```

```
      lbs | -.6672928 .2788087  -2.39  0.023  -1.234533  -
.1000523
```



```

      fd | -.128626 .2333278 -0.55 0.581 -.5859402
.3286882
      lbs | -.9451002 .2840259 -3.33 0.001 -1.501781 -
.3884196
      ifs | -.270256 .1012538 -2.67 0.008 -.4687099 -
.0718021
      _cons | 5.351205 1.080972 4.95 0.000 3.232539
7.469871

```

```

-----+-----
sigma_u | .10484051
sigma_e | .10508058
rho | .4988564 (fraction of variance due to u_i)
-----

```

```
. est store random
```

```
. hausman fixed random
```

```

----- Coefficients -----
      | (b)      (B)      (b-B)  sqrt(diag(V_b-V_B))
      | fixed   random  Difference  S.E.
-----+-----
      fd | -.5770399  -.128626  -.4484139  .2388188
      lbs | -.6672928  -.9451002  .2778074  .
      ifs | -.4943016  -.270256  -.2240456  .0366468
-----

```

b = consistent under Ho and Ha; obtained from xtreg
B = inconsistent under Ha, efficient under Ho; obtained from xtreg

Test: Ho: difference in coefficients not systematic

$$\text{chi2}(3) = (b-B)'[(V_b-V_B)^{-1}](b-B)$$

$$= 39.04$$

$$\text{Prob}>\text{chi2} = 0.0000$$

(V_b-V_B is not positive definite)

REUSLT FOR ROBUSTNESS OF RESULT

. regress tq fdd lbs lfs

Source	SS	df	MS	Number of obs =	48
-----+-----				F(3, 44) =	5.78
Model	.505754799	3	.168584933	Prob > F =	0.0020
Residual	1.28392461	44	.029180105	R-squared =	
-----+-----				Adj R-squared =	0.2337
Total	1.78967941	47	.038078285	Root MSE =	
-----+-----					

tq	Coef.	Std. Err.	t	P> t	[95% Conf. Interval]
-----+-----					
fdd	-.034102	.0535076	-0.64	0.527	-.1419395
-----+-----					
lbs	-1.043431	.3088701	-3.38	0.002	-1.665918
-----+-----					
lfs	-.0796622	.0882202	-0.90	0.371	-.2574584
-----+-----					
_cons	3.201572	.9755914	3.28	0.002	1.235397
-----+-----					

F test that all u_i=0: F(11, 33) = 7.93 Prob > F = 0.0000

. est store fixed

. xtreg tq fdd lbs lfs, re

Random-effects GLS regression Number of obs = 48

Group variable: id Number of groups = 12

R-sq: within = 0.6508 Obs per group: min = 4

between = 0.0086 avg = 4.0

overall = 0.2277 max = 4

Random effects u_i ~ Gaussian Wald chi2(3) = 51.40

corr(u_i, X) = 0 (assumed) Prob > chi2 = 0.0000

tq | Coef. Std. Err. z P>|z| [95% Conf. Interval]

-----+-----
fdd | -.1224484 .0636244 -1.92 0.054 -.24715
.0022531

lbs | -.8905583 .2634273 -3.38 0.001 -1.406866 -
.3742503

lfs | -.331206 .0926636 -3.57 0.000 -.5128233 -
.1495887

_cons | 6.053321 .9850142 6.15 0.000 4.122728
7.983913

-----+-----

```

sigma_u | .13265025
sigma_e | .10331876
rho | .6224109 (fraction of variance due to u_i)

```

```
-----
```

```
. est store random
```

```
. hausman fixed random
```

```

----- Coefficients -----

```

	(b)	(B)	(b-B)	sqrt(diag(V_b-V_B))
	fixed	random	Difference	S.E.
fdd	-.1611958	-.1224484	-.0387474	.0458519
lbs	-.7469735	-.8905583	.1435848	.0689053
lfs	-.461191	-.331206	-.129985	.0453208

```

-----

```

b = consistent under Ho and Ha; obtained from xtreg
B = inconsistent under Ha, efficient under Ho; obtained from xtreg

Test: Ho: difference in coefficients not systematic

$$\chi^2(3) = (b-B)'[(V_b-V_B)^{-1}](b-B)$$

$$= 10.10$$

Prob>chi2 = 0.0178

(V_b-V_B is not positive definite)

IMPACT OF MACROECONOMIC FACTORS ON NON-PERFORMING LOANS IN THE NIGERIAN DEPOSIT MONEY BANKS

BY

Dr (Mrs) YAHAYA, Khadijat Adenola
khadijatadenola@yahoo.com (+2348056664797)
Department of Accounting, Faculty of Management Sciences
University of Ilorin, Ilorin, Nigeria.

Mr. ONI , Opeyemi Oluwasegun
segunooni@gmail.com (+2348032319240)
Department of Agricultural Development Management,
Agricultural Rural Management Training Institute (ARMTI)
Ilorin, Kwara, Nigeria.

Abstract

Banking sector in Nigeria over the years has witnessed a number of crises that led to the distress of many banks. The crises, was caused and fueled by the high figures of non-performing loans and loan loss provisioning among other factors. This study therefore, investigated the factors responsible for non -performing loans in the Nigerian deposit money banks. A time series data were collected from Central Bank of Nigeria (2013), Financial Statistical Bulletin that covered the period 1989 to 2013. The study adopted Ordinary Least Squared technique via Error Correction Model to assess the non-performing loans and macroeconomic variables. The findings revealed that, Inflation, foreign exchange rate and credit to the private sectors are statistically significant with non-performing loans while Gross Domestic Product, Money Supply have no significant relationship with non-performing loans of the deposit money banks in Nigeria. Based on the findings, it was recommended that Central Bank of Nigeria should develop an institution that could take care of the effects of macroeconomic fluctuation in banks especially during inflation, currency devaluation and economic recession. In conclusion, deposit money banks in Nigeria should put into consideration macroeconomic

factors when offering loans in order to avoid the incidences of non-performing loans.

Keywords: Deposit Money Banks, Foreign Exchange, Inflation, Non-performing

loans, Macroeconomic factors

1.0 INTRODUCTION

The traditional role of a bank is lending and loans make up the bulk of their assets. Banks as intermediaries of funds are responsible for attracting resources and injecting it in the various economic sectors. However, in the process of resources allocation, banks while making profits, encounter several risks and nowadays, the most common risks is default risk, which is responsible for non-performing loans (NPLs). There are incidences of banks failure all over the world in the recent time which have made regulatory authorities to closed many banks. The collapse of banks usually affect the economy in many negative ways, it reduces the credit flow in the country which majorly affects the productivity and efficiency of the business units.

In Nigeria the era of supervision, examination and control of banks which started with the bank ordinance of 1952 and its subsequent amendments, was not without bank crisis. Also, the radical changes in financial developments in 1987 which brought about by the Structural Adjustment Programme of 1986 was not able to provide enough backbone for the financial industry as reflected by the unprecedented level of distress in banks which were characterized by large volume of non-performing loans, liquidity problem, insolvency, default in meeting depositors and inter-bank obligations. Consequently the issues of Non-Performing Loans (NPL) in Nigeria escalated in the later years as the amount of NPL for the distress banks increased from N2.9 billion to N29.5 billion in 1994 and 1995, respectively and later increased to N40.7 billion in 1997 while peaking at N149.6 billion in 2004 (Godwin 2012). This was practically one of the reasons for the recapitalization exercise of 2005.

However, barely four years into consolidation of the industry, (Sanusi 2010) reported that some banks have seriously exhibited varying symptoms of distress which necessitated CBN to bailout nine out of the twenty four banks with the sum of N620 billion in 2009 in order to prevent the occurrence of distress in the industry. The action of the CBN became necessary because, the shareholders funds and the balance sheet of the affected banks were impaired which caused them to have liquidity problem.

Consequently, in 2010, the Asset Management Corporation of Nigeria (AMCON) was established following the promulgation of its

enabling Act by the National Assembly. It is a machinery put in place to address the problem of non-performing loans in the Nigerian banking industry. In accordance with its mandate, AMCON was able to acquire non-performing risk assets of some banks worth over N1.7 trillion as at Dec, 2011 which greatly boost the liquidity as well as enhance the safety and soundness of the affected banks (Sanusi, 2012).

1.1 Statement of the Problem

The management of the Nigerian banks' asset portfolios has remained a major challenge as the issues of NPLs is one of the major causes of banks' failure in Nigeria which led to the consolidation exercise of 2005 (Babalola, 2010). However, four years after the consolidation of the banking industry, reports still show that some banks had exhibited varying symptoms of distress which necessitated CBN to bailout nine out of the twenty four banks with the sum of N620 billion in 2009 in order to prevent the occurrence of banks' distress in the industry (Sanusi 2010). In fact, the total non-performing loans of all the banks as at 31st Dec, 2012 stood at N286.09 billion representing 3.51% ratio of non-performing loans to total loan assets in percentages (NDIC, 2012).

Basically, non-performing loans create problems on the asset side for the banking sector's balance sheet. It creates a negative impact on the income statement as a result of provisioning for loan losses. NPLs can also create many other challenges for the banks and its stakeholders. Some of the important challenges are: Firstly, owners may not receive market returns on their capital investment and in a situation of bank failure owners may totally lose their assets. In recent times, this may affect a wide pool of shareholders. Secondly, depositors may likely not receive a market return on their savings and in the event of banks failure, depositors might lose their assets or uninsured balances.

In addition, Non Performing Loans (NPLs) may lead to economic contraction as a result of spill over to other sectors of the economy. This spillover effect can lead to illiquidity or bank insolvency (Hou, 2007). These problems are hard and fundamental and therefore require proper, radical and continuous attention to avoid further devastating impact, not only on the financial system and depositors but also on the overall national economy.

Generally, this study proposes to know the macro economic factors responsible for non-performing loans in Nigeria. The knowledge of the underlying factors is essential for managers of the banks and other stakeholders such as the Central Bank of Nigeria (CBN), bankers association, government and other financial authorities in their various policies formulation. In the light of the above problems, the research

question is “what effect do macroeconomic variables have on non-performing loans in the Nigerian banking industry”?

1.3 Objectives for the Study

The main objective of this study is to investigate the macroeconomic factors responsible for non-performing loans in Nigerian deposit money banks. The specific objectives of the study are to:

- i) determine the effects of inflation on non-performing loans of money deposit banks in Nigeria.
- ii) examine the effects of exchange rate on non-performing loans of money deposit banks in Nigeria.
- iii) assess the effects of GDP on non-performing loans of money deposit banks in Nigeria.
- iv) examine the effects of money supply on non-performing loans of money deposit banks in Nigeria.
- v) determine the effects of the credit supply to private sector on non-performing loans of money deposit banks in Nigeria.

1.4 Research Hypotheses

Based on the research questions, the following null research hypotheses were formulated:

Ho₁: There is no significant relationship between Non-performing loans (NPLs) and Inflation (INF).

Ho₂: There is no significant relationship between Non-performing loans (NPLs) and Gross Domestic Product (GDP).

Ho₃: There is no significant relationship between Non-performing loans (NPLs) and Foreign Exchange Rate (ER).

Ho₄: There is no significant relationship between Non-performing loans (NPLs) and Money Supply (M2).

Ho₅: There is no significant relationship between Non-performing loans (NPLs) and Credit Supply to Private Sector (CPS).

1.7 Justification of the Study

Many research works have been conducted on the factors responsible for non-performing loans in commercial banks in many part of the world such as Brownbridge, (1998); Dash and Kabra, (2010); Fofack, (2005); Munib, and Atiya,(2013) and so on. However, within the scope of the research, the factors responsible for non-performing loans have received scanty attention from the researchers in Nigeria. Most of the work on nonperforming loans in Nigeria focused on the effects of consolidation and risks on non-performing loans of banks such as Somoye (2010), Babalola (2010), Bebeji, (2013). Only Aremu, Suberu and Oke

(2010) and Agu and Basil (2013) considered the causes of nonperforming loans in banks using some bank specific factors such as interest rate, liquidity and credit administration methods of banks in Nigeria. This study therefore, focused on macroeconomic factors responsible for nonperforming loans in Nigeria as this area as not being covered based on the knowledge of the researcher.

The result from this work will be of assistance to managers of deposit money banks in Nigeria as it will enable them to have a better understanding and control of the various macroeconomic determinants that could significantly influence their lending decisions. Also, knowledge of these findings would be helpful to other stakeholders such as the Central Bank of Nigeria (CBN), Nigerian Deposit Insurance Corporation (NDIC), bankers association, government and other financial authorities in formulating on-going lending policies for Nigerian banks. Finally, the study will add to the existing and growing literatures on the determinants of non-performing loans in banks which can also serve as reference for future researcher interested in the subject matter.

2.0 LITERATURE REVIEW

2.1 Conceptual Framework

The conceptual framework will discuss the concepts of non-performing loans, classification and provisioning, as well as the macroeconomic determinants of non-performing loans in banks.

2.1.1. Non-Performing Loans

The term "bad loans" is used interchangeably with non-performing and impaired loans as identified in Fofack (2005). Berger and De Young, (1997) also considers these types of loans as "problem loans". Thus these descriptions are used interchangeably throughout the study. Normally, non-performing loan occur in a situation when both principal and interest on loan are outstanding for a long time contrary to the terms and conditions contained in the loan contract agreement. This is because going by the description of non-performing loans, it follows that any loan facility that is not up to date in terms of payment of both principal and interest contrary to the terms of the loan agreement, is non-performing.

2.1.2 Macroeconomic Factors Responsible for Non-performing Loans (NPLs) in Banks

It is imperative to highlight and discuss some of the macroeconomic determinants of non-performing loans in banks. Munib and Atiya (2013) identified the following as some of the macroeconomic determinants of non-performing loans in banks:

Gross Domestic Product (GDP): GDP is the market value of all goods and services produced in a country during a specified time, usually one year. Growth in GDP is considered as a symbol of country's

progression calculated with sum of private and public consumption with private and public investment if expenditure approach is used. A slow growth rate in developing countries (referred to a stagnant economy) shows that a country is suffering from recession where prices, output and employment levels are not maintained up to a desired level.

Money Supply: The total stock of money available in any economy during a specified time is called money supply. There are different forms of calculating money, and generally it is divided into three forms Reserve Money (Mo), Narrow Money (M1) and Broad Money (M2). In the study the researchers took M2 as the proxy of money supply as the most descriptive form of money also comprises the prior two categories. Reserve money shows the overall money available in tangible form while narrow money band includes reserve money and all demand and time deposits of schedule banks. M2 includes narrow money and all resident foreign currency deposits.

Inflation: This is an increase in general price level of goods and services in an economy up to a certain extent when a unit of currency buys fewer goods and services. Some economists say increase in the amount of money in circulation is referred to as inflation. Consumer Price Index (CPI) can be used as the proxy of inflation as a most comprehensive measure of inflation defines as a change in the price of consumer goods and services purchased by households. Increase in CPI compels monetary regulators to use contractionary measures by increasing the interest rates to control inflation which later increases the cost of borrowing and ultimately causes non-performing loans to come forth.

Exchange Rate: Exchange rate is the rate used to exchange one currency with another one. Exchange rates are determined by the continuous foreign exchange markets that remain opened for 24 hours a day except during weekends. It comprises wide range of different types of currency traders. This exchange of currency is largely influenced by exchange of capital goods and services across border called international trade. A decrease in home currency will result in costly imported goods which result in a pressure to finance letter of credits issued to trader by commercial banks; and risk of default increases. Therefore, an increase in exchange rate is positively associated with NPLs. We took USD /Naira as a proxy of exchange rate.

2.2 THEORETICAL BACKGROUND

The theoretical background adopted for this study is the bad luck theory that attempts to support the various factors responsible for non-performing loans in banks.

2.2.2 Bad Luck Theory

According to Berger and DeYoung, (1997), the macroeconomic

events such as bad performance of economy in the form decreased production level, high unemployment, failure of any sector, failure of manufacturing plant, energy crisis, unexpected events such as terrorist attacks; the economic activities in the country declines which results in the reduced earnings and profits of individuals and firms, leading to the growth in bad loans. In order to recover bad loans banks incurs extra operating costs in the form of additional monitoring expenses, attention divergence of top management, the costs of pricing, handling and disposing off collateral, negotiations with defaulters etc, as a result the increase in bad loans erodes banks cost efficiency in the form of increased monitoring and recovering costs.

2.3. Empirical Review of Non-Performing Loans

This section analyzed the empirical work brought by different researchers from different countries. In Nigeria, Nasiru, Joshua and Nasiru (2012) conducted a study titled "Banks' Recapitalisation in Nigeria: Resuscitating Liquidity or Forestalling Distress?" The data was collected from the Central Bank of Nigeria and the Nigeria Deposit Insurance Corporation for the period 1997-2006 using correlation analysis. Their results showed that there exist a relationship between increase in minimum capital base of the commercial banks and their liquidity and asset quality as both liquidity levels and asset quality tend to improve with recapitalization. Similarly, Bebeji (2013) applied both historical and descriptive approaches, in his paper, "consolidation and asset quality of banks in Nigeria using t-test to test the research hypotheses based on the secondary data collected from 10 sampled banks over the period 2002 through 2008. The study finds that consolidation has positive impact on non-performing loan.

In Pakistan, Munib and Atiya (2013) assessed the long and short run dynamics between nonperforming loans and macro economic variables covering the period from January 2002 till December 2011 of commercial banks in Pakistan. A long run relationship is found among variables by employing Johansen and Juselius multivariate cointegration, while pair wise bivariate cointegration reveals pair wise long run relationship between nonperforming loans with money supply and interest rate. Vector Error Correction Model was applied to determine the short run dynamics. The findings also revealed that weak short run relationship exist between Nonperforming loans, inflation and exchange rate. They concluded that macroeconomic factors are the main determinants of nonperforming loans in Pakistan.

In India, Dash and Kabra (2010) revealed that the real income variation negatively associated with NPLs and further probe that high interest rates, real effective exchange rate brought high level of NPLs. The study covers the time period of 1998-2009.

In Malaysia, Asari, Muhammad, Ahmad, Latif, Abdullah, and Jusoff (2011) applied vector error correction model by using stata software converting the data of 48 months belongs to commercial banks in Malaysia during 2006 till 2010 to unearth the relationship of inflation and interested rate with non performing loans. The study revealed a strong long run relationship between interest rate and nonperforming loans whereas inflation and interest rate have insignificant relationship in the long run. However, in short run both interest rate and inflation could not influence non performing loans. Further the casual relationship is found non directional.

In Rome, Sofolis and Eftychia (2011) used univariate regression to measure the impact on nonperforming loans in Romanian banking system. They concluded that inflation, unemployment rate, external debt to gross domestic product, Money supply and investment with construction expenditure jointly with country's (Greek) crises specific variables influence the credit risk of banking system and are the causes of NPLs. .

Finally, in Spain, Salas and Saurina (2002) investigated the determinants of problem loans of Spanish commercial and saving banks using a dynamic model through a panel dataset covering the period between 1985 and 1997. The study revealed that real growth in GDP is the major factors among others that explain variation in NPLs

3.0 METHODOLOGY

3.1 Research Design and Data Analytical Techniques

This study aims to empirically investigate the determinants of commercial banks lending portfolio in Nigeria covering a period of 24 years. In view of this, the study therefore, adopted a time series research design method. Secondary source of data was used in this research work. The data were obtained from Central Bank of Nigeria 2013 Statistical Bulletin: Financial Statistics which covered the period between 1989 and 2013. The deposit money banks were selected from the banking sector because it has a wider geographical coverage than any other financial institutions in the banking sector and also because deposit money banks control over 70% of assets and liability of the banking sector of Nigeria financial system (Ajayi, 2007).

3.2 Method of Data Analysis and Error Correction Model

The paper adopted econometric approach to test the degree of relationship between the variables by employing multiple regression analysis of the Ordinary Least Square (OLS) and Cointegration method using E-Views 7.0 package. In order to avoid a spurious regression result, Unit Root Test using the Augmented Dickey-Fuller (ADF) technique, was employed. Also, Serial correlation test and normality test were also conducted to estimate the reliability of the OLS model used in the study.

3.2.1 Regression Analysis

A regression describes and evaluates the relationships between a given dependent variable and one or more independent variables. Previous researches focusing on similar subject matter have found significant results applying regression analysis e.g. Munib and Atiya, (2013); Podpiera and Weill, 2008. Time series unit root test is first conducted to check for the stationarity of the variable series. If the unit root test shows that the variables are stationary at first order difference I(1), there will be need to test for co-integration among these variables. Co-integration may occur when a linear combination of variables that are I (1) produces a stationary series, then, the variables may be co-integrated (Engle and Granger, 1987). Given the fact that the variables are co-integrated, the next step is the estimation of the short-run dynamics using the error correction model. ECM incorporates the full short run dynamic model;

$$Y_t = \alpha + \beta y_t + \xi_t \dots\dots\dots(1)$$

Therefore

$$\Delta y_t = U_{t-1} + \sum \beta \Delta x_{t-1} + \sum \alpha_i \Delta y_{t-1} + \varepsilon \dots\dots\dots(2)$$

Here, U_{t-1} is the one period lagged value of the error term from co-integrating regression, while Δ denotes the first differences operator.

3.4 Models Specification

To examine the macroeconomic variables that cause non-performing loans in Nigerian deposit money banks, the study adopted and modified the model below from Munib and Atiya, (2013). The originally model is stated as: $NPL = \beta_0 + \beta_1 GDP + \beta_2 M2 + \beta_3 ER + \beta_4 TB + \beta_5 CPI + \mu t \dots\dots\dots(1)$ Where: NPL = Non Performing Loans, GDP = Gross Domestic Product, $M2$ = Money Supply, ER = Exchange Rate, TB = Treasury Bill, CPI = Inflation Rate, μt = Random Error.

The variable dropped was Treasury Bill (TB) while Credit to Private Sector (CPS) was adopted to obtain the desired result considering the percentages of non-performing loans in the private sector of the economy (Godwin, 2012). The time series data analysis covered the period between 1989 and 2012 covering the time before and after the banks consolidation era in Nigeria. The modified version of the model becomes:

$$NPL = \text{Proxy via } (NPL/TL) \dots\dots\dots (2)$$

$$NPL/TL_t = f (INF, GDP, ER, M2, CPS, \dots) \dots\dots\dots (3)$$

The explicit form of equation (1) above is represented as follows:

$$NPL/TL_t = \beta_0 + \beta_1 INF_t + \beta_2 GDP_t + \beta_3 ER_t + \beta_4 M2_t + \beta_5 CPS_t + U_t \dots\dots\dots (4)$$

When transformed into a log form equation 4 becomes:

$$NPL/TL_t = \beta_0 + \beta_1 INF_t + \beta_2 \log GDP_t + \beta_3 ER_t + \beta_4 \log M2_t + \beta_5 \log CPS_t + \mu_t \dots (5)$$

Where:

NPL/TL_t = Ratio of total Non-performing loans to total loans of all the commercial banks in Nigeria within the covered period (Dependent variable)

INF_t : It is the inflation rate in time period "t"

GDP_t : It is the growth in GDP in time period "t"

ER_t : It is the real effective exchange rate in time period "t"

$M2_t$: It is the money supply to the economy in time period "t"

CPS_t : It is the credit to private sector in time period "t"

U_t : error term controlling for unit-specific residual in the model

β_0 : intercept of the regression line

β (1 to 5) : coefficients to be estimated and their apriori expectations are as follows: $\beta_1, \beta_3, \beta_4$ and $\beta_5 > 0$ implies that the variables have a positive relationship with the dependent variable (LOA) while, $\beta_2 < 0$ shows that the variables have a negative relationship with the dependent variable (NPL). See figure1 at the appendix. The log of GDP, M2 and CPS were taken to give equal weight to all the observations since they were presented in Million (Naira) while other variables were presented in percentages. This is to avoid serial auto correlation given that the data covered a long period of 27 years.

4.0 ANALYSIS OF DATA COLLECTED

4.1.1 Pearson Correlation Coefficients.

Before the application of ordinary least square the study conducted a Pearson Correlation to ascertain the level of multi collinearity among the independent variables used in the study. See figure 2 at the appendix. Correlation coefficients between the different explanatory variables are low. The results of the tests conducted shows the absence of any multivariate multicollinearity problem, all the independent variable values are identified to be less than (0.4), which is in line with the threshold cited by Fox (1991).

4.2 Augmented Dickey-Fuller Test (ADF)

In this study, the Augmented Dickey Fuller (ADF) test for estimating unit roots was applied. The study revealed that all the variables were non-stationary in levels 1(0) since the ADF value of each variable at level is less than the MCKinnon critical value but became stationary at first difference or integrated of order one 1(1) See figure 3 at the appendix.:

4.3 Co-integration Test Result

Since the unit root test shows that the variables are stationary at first order difference 1(1), we therefore test for co-integration among these

variables. Cointegration may occur when a linear combination of variables that are I (1) produces a stationary series, and then the variables may need to be cointegrated (Engle and Granger, 1987). This means that a long-run relationship might exist between them, which connotes that they might wander from one another in the short-run but in the long-run they will move together. In view of this, we needed to establish whether there is a long-run relationship among the variables or not hence, we applied the Cointegration test using Johansen's multivariate method. See figure 4 at the appendix..

Using the trace likelihood ratio and Max-Eigen statistic results pointed out that there is cointegration among the variables up to three (3) cointegrating equations at 5% level of significance. This implies that there is presence of co-integration among the variables i.e there is long run relationship among the explanatory variables and non-performing loans.

4.4 Presentation of Regression Result

Given the fact that the variables of the three equations are co-integrated, the next step is the estimation of the short-run dynamics within the error correction model in order to capture the speed of adjustment to equilibrium in the case of any shock to any of the independent variables. An over parameterized error correction model of the ratio of non-performing loans output equation were estimated see figure 5 at the appendix.

4.5 Discussion of Findings

From the figure 6 (see at the appendix.), the study attempts to examine the joint impact of Gross Domestic Product D(GDP), Money Supply D(M2), Exchange Rate D(EXR), Credit to Private Sector D(CPS), and Inflation D(INF) on non-performing loans of the deposit money banks in Nigeria. It is apparent that a-priori, expectation of all the coefficients of the explanatory variables have the correct signs as expected and in conformity with the theoretical expectations.

The ECM result on (table 4.4) above disclosed that the estimated coefficient of Money Supply D(M2), Exchange Rate D(EXR), Credit to Private Sector D(CPS), and Inflation D(INF) are all positive. The positive sign on the coefficient established that each of these variables are positively related to issues of non-performing loans in the deposit money banks in Nigeria. This implies that for every 1% increase in Money Supply D(M2), Inflation D(INF) Exchange rate D(EXR) and Credit to Private Sector D(CPS) will cause non-performing loans of the deposit money banks in Nigeria to increase by 33.5%, 0.10%, 0.42% and 33.4% respectively. This result is in order with the economic a priori condition. Exchange Rate D(EXR) is significant at 1% level of significance while

inflation $D(INF)$ and Credit to private sector $D(CPS)$ is statistically significant at 5% level of significance. However, money supply is not significant at either 5% or 10%.

Also, the estimated coefficient for gross domestic product $D(GDP)$ are negative. The negative sign implied that there is an inverse relationship between Non-performing loans and $D(GDP)$ which means that for every 1% increase in $D(GDP)$ will cause the Non-performing loans of the deposit money banks to reduce by 2.04%. However, $D(GDP)$ is not statistically significant at either 5% or 10% level of significance. In a nutshell, three of the variables are statistically significant out of the five explanatory variables used in the model.

The result shows that the coefficient of Error Correction Mechanism (ECM) is negative -0.763090 and significant at 0.05 per cent critical level as evident by the low probability value of 0.0199. This shows that about 76.3 per cent disequilibria in the explanatory variables in the previous year are corrected in the present year. The importance of the ECM is an indication and a confirmation of the existence of a long run equilibrium relationship between non-performing loans and some of the explanatory variables. This implies that the banks' NPLs of the previous year significantly and positively affects the current year's performance.

The Durbin- Watson was 2.1 which is close to 2; this implied the absence of first order autocorrelation in the regression model (Field, 2005). Therefore, we can make valid prediction(s) with the equation. Moreover, the coefficient of multiple determinations - R-squared is 0.631155 which showed that 63% of the variation in Non-performing loans in the deposit money banks was caused by the variations in the explanatory variables as explained by the model. This showed that only 37 percent changes in the dependent variable was caused by other variables not found in the equation but measured by the error term. The F-statistics of 4.277911 is significant at 5 percent level of significance; hence the model was of good fit.

To authenticate the reliability of the result, serial correlation test and normality test were conducted. The Jarque-Bera test revealed 0.774382 which is not significant at 5% level of significance. This implied that the error term of the regression analysis is normally distributed (see figure 7 at the appendix.). Also, the R^2 is also less than the Durbin-Watson statistic meaning that ECM model is good. In addition to these, the serial correlation test of 0.5100 is also not significant at 5% which indicated that the error term is also not serially correlated see (table 4.6). Overall, the stability of the parameters from the ECM is remarkable, considering the great number of economical reforms implemented during the analyzed period.

4.6 Implication of Findings

From the regression results discussed above, some findings and implications can be highlighted. First, the co-integration test shows the existence of a unique long-run relationship between NPLs in banks and Credit to the Private Sector D(CPS), Inflation D(INF) and Foreign Exchange Rate D(FX). The error correction term also explains that about 76.3 % of errors made in the previous year would be corrected in the current year for banks in Nigeria.

The findings from the study, revealed that the macro economic variables responsible for non-performing loans in the Nigerian deposit money banks are Credit to the Private Sector D(CPS), Inflation D(INF) and Foreign Exchange Rate D(FX) while Money Supply to the Economy D(M2) and Gross Domestic Product D(GDP) do not significantly affect non-performing loans. The effect of inflation on NPLs emanated from the fact that it forces the lenders to adjust their lending interest rates upward to maintain their real return thereby curtailing the repayment capacity of the borrowers. Consequently, it reduces the debt servicing capacity of the loan holders. This is in line with the findings of Nkusu, (2011).

Also, the exchange rate is believed to have a negative effect on the loan payment capacity of borrowers in the country especially those that borrow in foreign currency due to the domestic currency depreciation within the period covered by this study. This is consistent with the findings of Fofack, (2005).

Furthermore, the stimulation of banking credit to private sector during the period covered was significantly responsible for non-performing loans as most of the loans granted to the private sector became bad due to national and international economic downturn experienced at the period as supported by (Godwin, 2012). Conclusively, the totality of the findings on macroeconomic factors corroborated the work of Brownbridge (1998), Muhammad et al, (2012) and Dash and Kabra (2010) which shows that macroeconomic instability was found to be an important cause of NPLs.

However, GDP and Money supply to the economy were not significantly responsible for NPLs in the Nigerian Deposit Money Banks. Though GDP has a negative relationship on NPLs the effects was insignificant within the period covered possibly due to low productivity and unemployment within the period covered by the study as most investments experienced low return on investment (Babalola, 2010). On the other hand, money supply into the economy by the government through the CBN also do not significantly affect NPLs of banks based on the argument that bulk of the loans given to clients came directly from the portfolio of banks.

Figure 8 (see Appendix) provides a snap shot of the summary of hypothesis Ho₁ to Ho₅. The null hypotheses of Ho₂, Ho₄, and Ho₅ were rejected and their alternative hypotheses accepted. However, the null

hypotheses Ho_1 , and Ho_3) were accepted and their alternative hypotheses rejected.

5.0 Conclusion

According to the research findings, it was possible to document the causes of nonperforming loans in Nigerian banks based on macroeconomic data. The work was carried out in line with the work of Munib and Atiya, (2013). The study revealed that exchange rate, inflation and credit supply to private sector are significant factors responsible for NPLs in Nigeria. Although there are many determinants of non-performing loans which can be macroeconomic, bank specific and customer related factors. However, unfavorable macroeconomic factor can be said to be the most important as it tends to influence all other factors and also that the factors are outside the control of banks. That is to say macroeconomic influences on banks are sometimes not predictable. This is supported by the bad luck theory that banks do not have control on macroeconomic factors that affects NPLs as previously discussed. Finally, like any research, this study has some limitations. Macroeconomic variables such as unemployment, consumer price index variables that were not used in the study could also be tested. Similarly, incorporating the lagged of the explanatory variables could also provide further information on the subject matter.

5.1 Recommendations

In the light of the above, the following recommendations are made in line with the results generated from the study:

1. Deposit money banks in Nigeria should take into account the real economic situation especially economic recession before extending loans. Commercial banks should extend its scope of macroeconomic surveillance to include prudential indicators so as to assess the soundness and stability of the economy.
2. Since macroeconomic factors are responsible for non-performing loans in Nigeria, policy makers through the monetary and fiscal policy instruments should increase domestic output production and diversify the economy from import based economic activity to an export based activity which is a panacea for exchange rate stability.
3. There should be strong and comprehensive legal framework that will aid in monitoring the performance of credit to private sector and recovering debts owed to banks.
4. The Central Bank of Nigeria (CBN) should formulate macroeconomic policies that can promote low inflation, favourable and stable exchange rate so as to enhance the capacity utilization of business and industries in Nigeria. This in

turn will enhance the credit expansion and profitability of the deposit money banks in Nigeria.

5. It is essential for banks to build system and skills in loan portfolio management, loan delinquency management, foreign exchange management and also macroeconomic management.
6. Finally, the introduction of Assets Management Corporation of Nigeria (AMCON) to buy toxic loans from banks is a step in the right direction. However, CBN should develop or establish an insurance product or institution that could take care of the effects of macroeconomic fluctuation in banks especially during inflation, currency devaluation and economic recession. This will protect the banks from negative macroeconomic occurrences.

REFERENCES

- Agu, O. C., & Basil, C. O. (2013). Credit Management and Bad Debt in Nigeria
Commercial Banks Implication For development. *Journal of Humanities and Social Science*, 12 (3), 47-56.
- Ajayi, M.A. (2007). The Determinants of Loan and Advances in the Financial System:
An Emperical Evidence from Nigerian Commercial Banks. *Journal of Business and Social Sciences*, 12 (1), 10-20.
- Aremu, O. S.,Suberu, O. J., &Oke, J. A. (2010). Effective Credit Processing and
Administration as a Panacea for Non-Performing Assets in the Nigerian
Banking System.. *Journal of Economics*, 1 (1), 53-56.
- Asari, F.H., Muhammad, N.A., Ahmad, W., Latif, N.I.A., Abdullah, N. & Jusoff, K., (2011).
An Analysis of Non-Performing Loan, Interest Rate and Inflation Rate Using
Stata Software. *World Applied Sciences Journal*, 1 (4), 10-15.
- Babalola, A. (2010). Bank Failure in Nigeria: A Consequence of Capital Inadequacy, Lack of
Transparency and Non-Performing Loans?*Business Perspectives, Journal of Bank and Bank System*, 1 (6), 32-35.
- Bebeji, A. (2013).Consolidation and Asset Quality of Banks in Nigeria:
International Journal of Business and Management Invention.2 (2),12-20.
- Berger, A., & DeYoung, R. (1997). Problem Loans and Cost Efficiency in Commercial
Banks. *Journal of Banking and Finance*, 21 (11), 849–870.
- Brownbridge, M., & Harvey, C. (1998) Banking in Africa: The Impact of Financial

Sector Reform since Independence, James Currey, Oxford, Africa World Press,
Trenton, E.A.E.P., Nairobi, and Fountain Publishers, Kampala.

Central Bank of Nigeria (2010): Prudential Guidelines.

<http://www.cenbank.org/document.asp>. Retrieved on 5/7/2013

Central Bank of Nigeria (2012) Statistical Bulletin: Financial Statistics.

<http://www.cenbank.org/documents/Statbulletin.asp>. Retrieved on 5/7/2013

Dash, M., & Kabra, G. (2010). The Determinants of Non-Performing Assets in

Indian Commercial Bank: An econometric study. *Journal of Middle Eastern*

Finance and Economics, 7 (12), 94-106.

Engle, R.F., & Granger, C.W. (1987). Co-Integration and Error Correction, Representation, Estimation and Testing *Econometrics*, 55 (2), 251-276. Field, A.

(2005). *Discovering Statistics Using SPSS*. London: SAGE Publications.

Fofack, H. (2005), Non-Performing Loans in Sub-Saharan Africa: Causal Analysis

and Macroeconomic Implications. World Bank Policy Research Working Paper no 3769.

Fox, J. (1991), *Regression Diagnostics: An Introduction*. Newbury Park, CA: Sage.

Godwin, C. O. (2012). Soundness and Unsoundness of Banking Sector in Nigeria:

A Discriminate Analytical Approach. Department of Banking and Finance, Abia

State University Uturu-Nigeria, MPRA Paper No. 36474.

Hou, Y., (2007), The non-performing loans: some bank-level experiences. *4th AFE-*

QASS Conference, INEAG, Samos.

Jimenez, G., & Saurina, J. (2005). Credit Cycles, Credit Risk, and Prudential Regulation.

- Munib, B., & Atiya, Y. J.(2013). Impact of Macroeconomic Forces on Non-Performing Loans: An empirical study of commercial banks in Pakistan. *WSEAS Transactions on business and economics*, 1 (10), 34-40.
- Nasiru, Joshua, & Nasiiru.(2012).Bank Recapitalisation in Nigeria: Resuscitating Liquidity or Forestalling Distress? *International Journal of Business and Social Science*, 3 (10), 26-29.
- NDIC (2011, 2012 & 2013) Annual Report & Statement of Accounts: www.ndic.org.ng.
- Nkusu, M. (2011). Nonperforming Loans and Macro financial Vulnerabilities in Advanced Economies. *IMF Working Paper 11(16)*. Non-Performing Loan. Source: <http://teachmefinance.com/> Retrieved on 1/2/2014.
- Salas, V., & Saurina, J. (2002), Credit Risk in Two Institutional Regimes: Spanish Commercial and Savings Banks. *Journal of Financial Services Research*, 22 (3), 203-224.
- Sanusi, L.S. (2010). Global Financial Meltdown and the Reforms in Nigeria. Being the Public Lecture Delivered by CBN, Governor at Convocation Square, Abubakar Tafawa Balewa University, Bauchi. Retrieved 1/1/2014, from www.cenbank.org/out/speeches.
- Sanusi, L .S, (2012). Banking Reform and Its Impact on the Nigeria Economy. *CBN Journal of Applied Statistics*, 2 (2), 30-35.
- Sofoklis, D. V., & Eftychia N. (2011). Investigating the Determinants of Non- Performing Loans in the Romanian Banking Systems: An Empirical Study with Reference to the Greek Crisis" Hindawi Publishing Determinant of Non-Performing Loans" Special Feature 132-139.

Somoye, R.O.C. (2010). The Variation of Risks on Non-Performing Loans on Bank

Performances in Nigeria, *Indian Journal of Economics and Business*, 9 (1), 45-49.

Appendix

Figure 1: Apriori Expectations on Macroeconomic Variables' Relationship with NPLs

Variables	Relation with NPLs	Supporting Scholars
Growth in GDP	-	Dash and Kabra, Shu, (2002); Rajan and Dhal, (2003); Fofack, (2005); Munib and Atiya, (2013)
Money supply	+	Badar and Javid, (2013); Munib and Atiya, (2013)
Inflation	+	Babihuga, (2007); Dash and Kabra, (2010)
Exchange rate	+	Fofack, (2005); Munib and Atiya, (2013)
Credit to Private Sector	+	Fofack, (2005)

Source: Author's research work, 2015.

Figure 2: Pearson correlation coefficients of different exogenous variables

Variables	CPS	FX (N-\$)	GDP	INF	M2
CPS	1.000000				
FX/N-\$	0.318431	1.000000			
GDP	0.382210	0.211174	1.000000		
INF	-0.341170	-0.414011	-0.367137	1.000000	
M2	0.297268	0.233855	0.387614	-0.338653	1.000000

Source: Author's Computation, 2015

Figure 3: Augmented Dickey-Fuller (ADF) Unit Root Test for Macro Economic Variables (1989 to 2013) Constant and Trend Included

Variables		ADF Calculated Value at Level	ADF Calculated Value at 1 st Difference	McKinnon at Critical Value	Order of Integration
LCPS CPS**	=	-1.3047	-3.830908	-2.9131	I (1)
FX Fx***	=	-0.7751	-4.458342	-3.1229	I (1)
LGDP GDP**	=	-1.2277	-4.338961	-2.6900	1(1)
INF INF**	=	-0.4168	-4.612655	-2.3451	1(1)
LM2 ***	= M2	-0.8926	-6.418225	-3.4141	1(1)
NPL/TL NPL/TL**	=	-2.1806	-4.132085	-2.9271	1(1)

Source: Author's Computation, 2015

Note: ***Significant at 1 per cent level of significance, **Significant at 5 per cent level of significance

Figure 4: Johansen's Multivariate Cointegration Test

Hypothesized No. of CE(s)	Eigenvalue	Trace Statistic	0.05 Critical Value	Prob.*	Max-Eigen Statistic	0.05 Critical Value	Prob.**
None *	0.982901	183.9257	95.75366	0.0000	89.51198	40.07757	0.0000
At most 1 *	0.846463	94.41375	69.81889	0.0002	41.22397	33.87687	0.0056
At most	0.750838	53.18978	47.85613	0.0145	30.57230	27.58434	0.0200

2 *							
At most 3	0.4018 13	22.617 48	29.797 07	0.265 4	11.304 75	21.131 62	0.61 69
At most 4	0.3449 02	11.312 73	15.494 71	0.193 0	9.3053 50	14.264 60	0.26 16
At most 5	0.0872 06	2.0073 81	3.8414 66	0.156 5	2.0073 81	3.8414 66	0.15 65

Source: Author's Computation, 2015. Trace test indicates 3 cointegrating eqn(s) at the 0.05 level

* denotes rejection of the hypothesis at the 0.05 level. While ** denotes MacKinnon-Haug-Michelis (1999) p values.

Figure 5: Regression Analysis of the Error-Correction Model

Dependent Variable: D(NPL/TL)			
Variable	Coefficient	T-Statistic	Prob.
C	5.082902	1.051339	0.3097
D(M2)	33.59839	1.377499	0.1886
D(INF)	0.100226	0.671384	0.0122
D(GDP)	-2.048758	-0.184966	0.8557
D(FX (N/\$))	0.428541	4.280206	0.0007
D(CPS)	33.40110	2.686422	0.0169
ECM =U(-1)	-0.763090	-0.231661	0.0199
R-squared	0.631155		
Adjusted R-squared	0.613617		
F-statistic	4.277911	Durbin-Watson	2.085407
Prob (F-statistic)	0.010396		

Source: Author's Computation, 2015.

Figure 6: Normality Tests of Residual

Jarque Bera	Probability
0.774382	0.678961

Source: Authors' Computation, 2015

Figure 7: Breusch-Godfrey Serial Correlation LM Test

Obs*R-squared	Prob. Chi-Square(2)
1.346704	0.5100

Source: Authors' Computation, 2015

Figure 8: Findings on Hypothesis Ho₁ to Ho₅.

Hypotheses	Variables	Findings	Decision
Ho₁	There is no significant relationship between NPLs (NPLs/TL) and (M2).	No Significance	Reject
Ho₂	There is no significant relationship between NPLs (NPLs/TL) and (INF).	Significance	Accept
Ho₃	There is no significant relationship between NPLs (NPLs/TL) and (GDP).	No Significance	Reject
Ho₄	There is no significant relationship between NPLs (NPLs/TL) and (EXR).	Significance	Accept
Ho₅	There is no significant relationship between NPLs (NPLs/TL) and (CPS).	Significance	Accept

Source: Researcher's Design, 2015

DETERMINANTS OF MOTOR *TAKAFUL* PATRONAGE AMONG COMMERCIAL VEHICLE OPERATORS: A CONCEPTUAL REVIEW

Habiba Ali **Yaqub**
Postgraduate Research Fellow,
International Institute of Islamic Banking and Finance,,
Bayero University, Kano, Nigeria

and

Kabiru Isa **Dandago** PhD, FCA, FNIM, MNES, ACTI
Professor of Accounting, Department of accounting,
Faculty of Social and Management Sciences,
Bayero University, Kano, Nigeria
kidandago@gmail.com, _ +2348023360386

Being a full paper for presented at the 1st Academic Conference of the
Institute of Chartered Accountants of Nigeria (ICAN), held at the Lagos
Airport Hotel, Lagos, Nigeria
May 2015

ABSTRACT

Takaful is an innovative model of Islamic insurance that is well developed
in Asia and has shown tremendous potentials for promoting growth and

development in that continent ((Razak *et, al.* 2013). Although it is not well adopted by insurance companies in Africa, especially in Nigeria, the importance of creating the awareness of participants and potential operators of *takaful*, as a means of societal regeneration and social well-being cannot be overemphasized. Patronage of *Takaful* services would depend, to some extent, on proper understanding of what it offers. This study intends to assess the determinants of patronage of motor *takaful* products and services among commercial vehicle users. The paper is conceptual in nature, as it relies on the literature to identify the major determinants of *Takaful* services patronage. The findings suggest that product, features, promotion, benefit and service quality are the major factors/determinants that influence the patronage of motor *takaful* by commercial vehicles operators across the globe. The paper recommends that the existing potential *takaful* operators and insurance companies with *takaful* windows should focus on these determinants of *takaful* patronage in order to attract and retain customers of *takaful* services, especially commercial vehicle operators in Nigerian and beyond.

Keywords: Determinants, Takaful patronage, commercial vehicle operators, Islamic insurance, Takaful participants

1.1 INTRODUCTION

Takaful is an innovative form of Islamic Insurance that has been legalized to operate in Nigeria as an alternative to that of the conventional insurance. One of the ideas for implementing Islamic insurance in Nigeria by the Nigeria by the National Insurance Commission (NAICOM) Federal Government agency is to serve the needs of Muslim population and other individuals who need ethical financing as to enhance patronage level of insurance. The concept of *takaful* is derived from Islamic law, it is a foundation of sharing responsibility that was prescribed by the system of *Aaqilah* as an arrangement of mutual help or indemnification, customary in some Arab tribes and also at the time of the Prophet peace be upon him (*PBUH*) (Anwar, 2008 & Ali, 2009).

Muslims jurists have acknowledged the scheme of *takaful* as a mean of Islamic insurance unlike that of the conventional that contains *Riba* (usury), *Maysir* (gambling) and *Gharar* (uncertainty) elements that are prohibited in Islamic law (Matasawali, *et. al.* 2012). According to Fisher & Taylor (2000) *takaful* plays a crucial role in Islamic economic development, as it is based on brotherhood support, charity, mutual assistance and self-sustaining spirit that cannot be found in any other financial instrument.

The scheme of *takaful* has made potential impact in promoting growth and development in Aisa (Razak *et. al.* 2013). In term of general *takaful* it has been commented by Raham, *et. al.*, (2008), that motor *takaful* product contribute significantly to generate *takaful* scheme compared to other products in the scheme of general *takaful*. In a study by Alpen (2010), as cited by Ayinde & Echchabi, (2012), the study reveals high adoption of motor *takaful* compare to that of health *takaful* which was due to the compulsory government requirement of motor and health insurance.

In Nigeria, a mandatory insurance cover is required for all vehicle owners in which the initiation of *takaful* scheme as an alternative to the conventional, it is seen as a base for enhancing the level of insurance patronage. Despite the mandatory requirement for every vehicle owner to have an insurance cover and with the introduction of three Islamic insurance firms in Kano metropolis to facilitate the patronage, the scheme of *takaful* is still not popularly known among individuals. Ayuba (2013), affirms that there has not been any report on the success of *takaful* patronage in Nigeria. Hence, it could be said that the potentials of *takaful* is not well utilized. For an innovative products and services like *takaful* to gain popularity, it should not depend on the benefits around what it has to offer but also the proper understanding of factor that could influence its patronage among individuals.

If Muslims consider conventional insurance as unethical or against the teachings of Islam, and there is the requirement for mandatory insurance certificate for motor vehicle owners, then what opportunities does motor *takaful* presents for commercial vehicle owners in Kano State? The existence of motor *takaful* products and its potential have not grown to the extent of attracting huge customers. Therefore a great need for effort by the industry to focus on key factors that could enhance patronage of this innovative products and services is needed.

It is in view of the above therefore, that this study focuses on the determinants of motor *takaful* products and services patronage among commercial vehicle users. The study will be of benefits to the *takaful* industries where it seeks to highlight the framework to formulate and

implement marketing strategies to enhance patronage level. The study is limited to factors that influence patronage of motor *takaful* products and services among commercial vehicle operators in Kano metropolis, Nigeria.

LITERATURE REVIEW

This section deals with the concept of *takaful*, origin and classification, overview of Motor *takaful*, *takaful* in Nigeria and determinant factors that influence patronage of motor *takaful*.

2.2 Concept of Takaful

The concept of *takaful* is based on *Ta'awun* (mutual assistance) and *Tabarru* (donation). "*Takaful*" is derived from the word "*Kafala*" which means to guarantee, guard and protect. "Takaful is guaranteeing and assisting each other". In the context Islamic interpretation, *takaful* is a pact among members to give mutual assistance to one another (Takaful Brunei Darussalam, 2011).

Yusof 1996, defined *takaful* as an agreement among members who agree to jointly contribute to guarantee themselves against loss or damage that may inflict upon any of the participants. *Takaful* is said to be a financial transaction/ arrangement based on the principles of co-operation, *mudarabah* (profit & loss) and *tabarru* (donation) whereby the *takaful* operator and participants both benefit from the profits realized from the contributed funds as agreed in the contract (Billah, 2001).

The scheme of *takaful* is a financial agreement transaction based on the principle of co-operation *mudarabah* (profit & loss) and *tabarru* (donation). All members in the scheme are involved in the technical and the investment surplus of insurance and the reinsurance funds. The management of funds is been operated by the company. The business operation is strictly focused on the aspects of social goodness based on the principles of *Sharia'h*.

In the modus and operandi of *takaful* contract if a participant is indemnified for his /her loss, surplus acquired at the end of the contract will be distributed to participants without claim after which operation cost it deducted as agreed in the contract. (Arbouna, 2000; Swart & Coetzer, 2010; & Marhanum, *et. al.* 2013).

2.3 Classification of *Takaful* Scheme

Family *takaful* is a long term contract of savings and protection for participants and their dependents arising from death, disability. The *tabarru* (*voluntary donation*) aspect contributed by the participant enables him to fulfill his obligation of mutual help and joint guarantee and to eliminate both the element of *gharar* (uncertainty) and *maysir* (gambling) in the policy. The *mudarabah*, which is the profit-sharing element between the participants and the *takaful* operator enable both parties to reap some worldly benefits.

Awang & Zakaria (2009) and Ismail (2011) pointed out that a portion of the contributed funds by each participant is set aside as *tabarru* (*voluntary donation*) while the rest will be invested under the concept of *mudaraba* (profit and loss). In the event any calamity befalls on a member, he/she will be indemnified in respect of any damage or loss while profit yielded from the invested funds will be distributed as per agreed ratio in the contract.

General *takaful* is the short term contract which is categorized as motor *takaful* cover, fire cover, marine *takaful* covers (Ismail, 2011). In general, *takaful* is built on different business scheme. Dandago, (2012), comment that *takaful* can be operated in different dimensions depending on its suitability and flexibility of the objective it is posed to achieve in any society. In many cases general *takaful* is built on the principle of *al-tabarru* (donation) normally on an annual basis to cover a stipulated period. In the event of loss participant will be indemnified while the excess of the fund, if any, will be refunded to the participant subject to the situation where no claim of damage is made by the participant (Ismail, 2011).

In the scheme of general *takaful*, the *tabarru* (donation) element is more apparent as participants will normally undertake to regard their contributions as donation to fellow participants. All contributions goes to a pool of funds in the name of *tabarru* to compensate participant in the event any calamity occurs (ISRA, 2012). Although in some instances the scheme of general *takaful* is based on investment after which some sizeable portion of the participants' contribution is donated as *tabarru* and the rest for investment scheme as agreed in the policy (Billah, 2003).

Overview of Motor *Takaful*

In a *takaful* motor scheme, a participant enter into a contract of agreement to mutually contribute to assist each other if loss of hazards occurs, and when such hazard occurs a participant will be compensated

based on the types of perils and at maturity of the contract if a participant do not received any claim during the period of the contract that participant is entitled to share of surplus as per agreed ratio (Yassin & Ramil, 2011).

In the scheme of motor *takaful*, vehicles are classified into three categories, namely, private vehicle *takaful*, commercial vehicle *takaful* and motorcycle *takaful*. As stated by Yassin & Ramil (2011) and Dandago (2012). On the one hand Private vehicles *takaful* deal with individual personal car and cars for business purpose owned by companies or private business for public services only. On the other hand commercial vehicles *takaful* deals with two types of vehicle, motor used for commercial purpose for long distance or short distance and the goods carrier vehicle while motorcycle deal with auto cycle, machine and scooter.

ISRA (2012), Sabbagh (2012) & Alhumodi (2012), categorize motor *takaful* coverage into three, namely: own damage, legal liabilities and comprehensive. The first denotes a *takaful* form of cover that indemnify a participant against any property damage, loss of vehicle, injury caused by a third party or anybody; while the second, on the other hand, signifies the *takaful* claimant's cost and expenses which the participant shall become legally liable to pay off such as death of or bodily injury to any person, damage to property other than property belonging to participant or held in trust by or in cost or control of the participant. The third, however, is a *takaful* scheme which covers all kinds of loss and damage inflicted upon the participant, his property or against third party and his property.

The motor *takaful* is a pact among practicing members to mutually assist any of them who suffer a loss or accident while the *takaful* operator act as managers who will manage the fund either in any claimant activities, investment purpose or distribute surplus after *retakaful*. Therefore, policy of motor *takaful* scheme create avenue for acquiring cash back in it's underlying concept (Rahman, *et. al.*).

2.5 Procedure for Claims

In a *takaful* scheme when a participant faced loss or damage caused by motor accident, the claim procedure include documenting names and addresses of people involved, witness, registration number and model of

cars involved; in addition, taking a safety precaution by, lodging a police report within 24 hours of the accident, notifying the *takaful* operator immediately after the accident. Lastly, the participant is required to send all documents together with the claim form to the claims department (Ismail, 2011).

It is possible to lay claim as third party when theft of vehicle is involved, however participants are advised not to admit liability to third part and/or any other claim. The participant is to inform his operators of any third party or potential third party claim also when a claim involving theft of vehicle a participant is to make all necessary report and notifying his /her operator within 24 hour of the stolen vehicle including a written submission of the claim form (Ismail, 2011).

The scheme of *takaful* serve the same purpose like that of the conventional insurance but differ in the sense that the *takaful* of objective is based on the principle of Islam *Maqasid al Shariah* (Kollere, 2015). Maysami and Kwon (1999), are equally of the view that *takaful* is an Islamic model of insurance policy which is based on the fundamental principle of mutual cooperation and solidarity as mentioned in the Holy Quran. Pfeffer, (1956), however is of the view that insurance is a device for risk reduction of one party, called the insured, by way of risk transfer to another party (third party), called the insurer, who offers a restoration in the event of losses suffered by the insured there is no religious boundary under conventional insurance. The main purpose of insurance is just for commercial in the sense of protecting risk-averse from suffering the full cost of those actions on the part of nature which affect them unfavorably.

According to Kollere, (2015) *takaful* is also a contract based on mutual contribution by the participants, unlike that of the conventional where contract is based on sale or purchase contract between policyholders and insurers. The aspect of donation is treated in the *takaful* contract agreement where each participant willfully relinquishes a certain proportion of his contribution to assist others in the scheme. However in the *takaful* scheme ,funds are contributed by participants and operators make use of participants' contribution only for the intended purpose of "joint guarantee" while in conventional insurance the operator use the premium paid by policy holders in investments in order to suit his shareholders' needs.

Though, muslim jurists agree on loss- sharing, that does not contradict the *Shari'ah* and compensation to any individual is accepted and encouraged in Islam. According to Siddiqi (1985), there are three

elements that make conventional insurance disapproved in the Shari'ah law: (i) *Al-Gharar* (uncertain) a practice of conventional insurance contract where policyholders do not have ideas of the regulatory system of their funds paid as premium. (ii) *Al-Maisir* (gambling) this occurs when the policy holder will not receive any dividend from the premiums paid in a situation where no risk has occurred. On the other hand, participants get compensation where a misfortune occurs whilst paying a small premium. In *takaful*, even though the risk does not occur, the participant is entitled to get surplus at the end of the *takaful* contract. (iii) *Riba* (interest).

The policy loan in conventional life insurance is in fact a *Riba* based transaction and Islam prohibits any investment activities which are interest-based and non-*Halal* products. Under *takaful* contract every policy holder is entitled to know how their money is used, how the surrendered value is calculated, and such policy holders must be certain that neither returns nor funds paid out in claim settlements, is from unlawful means such as investments in stocks of companies producing non-halal goods but in conventional insurance policy holder have no right to know about this (Arbouna, 2000).

In any Islamic insurance company, there must be a *shari'ah* supervisory Board to ensure that the company activities do not contradict the rules of Islamic *Shari'ah* and to guarantee that the company is committed to the rules and regulations of Islamic *Shari'ah* in its practice. Any Islamic insurance company must comply with the guidance, directions, decisions, and judgments issued by its *Shari'ah* supervisory Board.

According to the Institute of Islamic Banking and Insurance (2012), the role of the *shari'ah* supervisor board is to review the *takaful* operation, supervise the products, investment scheme and determine the *shari'ah* compliance. Mostly the *shari'ah* supervisory carry their own independent audit and certify that nothing relating to any of the operations involves any element that is prohibited by the *shari'ah*.

In conclusion, it is clear that *takaful* and conventional insurance are premiums known today in the insurance industry. While the conventional insurance is commonly known all over the world, *takaful* is known quite recently in both Muslim and non-Muslim countries. Both indemnify risks.

Takaful however, is both an insurance policy as well as an investment scheme. Conventional insurance however is risk prone. This could be seen where a policy holder would purchase insurance for a period of one year without having accident, calamity or misfortune yet will not get any dividend at the end of the policy year; where as in takaful he/she gets value for his invested capital accident or no accident.

2.6 Determinants of *Takaful* Patronage

On the determinants of Islamic insurance (*takaful*) patronage, several studies on Islamic finance and Islamic banking that relate to those determining factors were carried out, that lead to the clear understanding of determinants of Islamic insurance (*takaful*) patronage.

2.6.1 Service quality

Service quality is the modest act offers by companies that lead to customer's general judgment attached to the product and services. Customers perceived service quality from different view like past experience and word of mouth (Tiwari, et. al. 2012). Idirs, et. al. 2011, pointed out that service quality varies in many forms such as, treating customers with courtesy and respect, efficiency and effectiveness in deal with transactions and knowledge of addressing issues pertaining to Islamic product and service. According to Raham, Abdelfattah & Mohamad (2014), many studies have focused on service quality and the use of SERVQUAL model to test service quality since it plays important role in the area of firms' performance.

Ancarani & Capaldo (2001) noted that service quality is one of the key focuses of many industries including insurance companies. In the area of Islamic banking and finance, service quality have become a significant issues due to the increasing competitive market around the globe which have become more necessary of Islamic bank and finance to maintain position in the market (Sheriff, 2012). Consumers' preferences of product and services is mostly based on the quality of services provide by companies. In the context of services, consumers' satisfaction stand as an antecedent of service quality (Bitner, 2001). Service quality affect the customer patronage through the customer satisfaction relationship (Raham, Abdelfattah & Mohamad,2014).

In insurance service quality constitute an internal and external factor and could be measured through modified tools such envisages the generic dimensions, tangibility, reliability, responsiveness, assurance and

empathy (Parasuraman et al, 1988; Tiwari,*et. al* .2012).In consumer behavior research it's found out that when the quality of services is delivered to customers, it eventually creates a good relationship. It could be said that good /high Service quality lead to more sales and profits by engaging customers to repeat or extend purchases in order to achieve success business.

2.6.2 Promotion

Promotion provide utilitarian benefits to a given products in the sense that it increase awareness. Promotion are advertisement, sales bonus and various exciting benefits used as a modes by companies so that their products should be known and accepted by the public (Abdul Aziz, 2011). It is commonly know that promotion is one of the useful tools used by organizations to popularize their new initiative products in the market.

Maizaitulaidawati & Asmak (2013) noticed that *takaful* operators use promotional tools to attract customer's attention and to create a positive brand image in the customers' mind. One of the avenues used by the *takaful* operators is public relation through existing networks such as in-house publications, billboards advertising, and printed advertisements including pamphlet and flyer to cater wider demographic segments. This strategy is one of the effective and less costly means of brand enhancement. As *takaful* products and services are different from the conventional ones, their promotional strategies also vary. In managing promotional tools, *takaful* operators also comply with Islamic principles. According to Barry (1987), individuals must first be aware from advertisers, then transmit the message, later develop interest resulting from the awareness and comprehension stages, which will finally reach a stage to act (positive/negative) towards the advertiser product or service as a result of the message.

Abdul Aziz,(2011) added that promotion is well known It is one of the vital parts for an organization especially when new products or services are entering the market. *Takaful* operators should aggressively use this tool in order to reach the segmented market if they wish to get more customers to subscribe and become policy holders of the Motor Islamic insurance policies among the society which is in accordance to the *Shari'ah* principles.

2.6.3 Benefits

Benefits derived from a products is one of the needs consumers focus on when patronizing products and services. Abdul Aziz (2011), cited Henry Assael (1995) that benefit is one important factor consumers consider when choosing a brand. Marketers have discovered that benefits such as performance, economy and style are what consumers stress on in products and services for that, companies develop product that satisfy these benefits (Abdul Aziz, 2011). As such, consumers always perceive the features of a product as one of their object that may or may not satisfy their benefits. (Abdul Aziz, 2011).

2.6.4 Products

The product of companies is important since it is linked to the awareness of the product among consumers (Bashir, 2012). Industries must clearly understand the different attitudes perceived on service quality of product by the Customers because it will influence the consumer awareness and product, service quality and awareness are important tools to achieve customer satisfaction (Bashir, 2012).

Hamid & Nordin (2001), viewed that poor knowledge of specific Islamic banking product and lack of understanding of the difference is between Islamic product and that of conventional banks is common with individuals. Consumer's acceptance of any product is link to their experience of using a product. Company can provide a positive or good image to their consumers with quality product that will give a good experience to their potentials customers (Soderlund, 1998).

2.6.5 Features

Features are attributes that a product has, which attract additional value to the product. Islamic financing system is built on various features which are; equitable, fair society and economic order. Firstly, prohibition of interest (*riba*) in the Islamic financial system to avoid exploitation, to avoid profiteering through manipulation prices and to protect the poor Secondly, Islamic financial system stresses the principle of cooperation and brotherhood, in which the system of risk-taking, profit-and-loss-sharing that help the productivity of the business is upheld. Thirdly, Islamic finance is grounded by the strict ethical criteria of Islamic law or *Shariah*. (Mirakhor & Iqbal, 2011). Features present the capability of a product or service that provide customers with idea about efficient the

product or service will deliver its benefits, However benefits are more important than features of a product (Kauffman, 2015).

When there is availability of products that serve the same purpose basic on benefits, a unique feature may provide a competitive advantage (Kauffman, 2015). Based on these, it could be said that Islamic insurance and that of conventional serve the same purpose but the features of each distinguish one from the other. The modus and operandi of Islamic product make it attracted to many individuals.

2.6.6 Religion

Religion is *deen*, an obligation that is expected by individual to perform and relate it in all acts of life (Amin et al., 2011). Kirkpatrick (2005) defined religion as devoted behavior that is attached to a powerful emotional relation to the ways individuals act to things. Wan Ahmad et al. (2008) comment that individuals who had acquired depth religious education exposures tends to subscribe to Islamic financing products.

Zaher & Hassan (2001), affirmed that religions have influencing factors over customers in patronizing Islamic banks. Idris et al. (2011) added that religious values stand as the most significant factor of influence among institutions of higher learning to patronize Islamic banking. The requirement of Islamic religion is what necessitates many Muslims to patronize Islamic products. Some only select Islamic banks due to that fact that it is what religion said and required (Awan & Azhaf 2014).

Many literature reviews on attitude towards Islamic banking have affirmed the importance of Shariah-compliancy products and services in customers' bank selection. The concept of Islam finance is based on the injunction of Islamic principle Islamic finance are as follows: (i) the prohibition of *Riba* (usually interpreted as usury or interest) and the removal of debt-based financing; (ii) the prohibition of *Gharar*, encompassing the full disclosure of information, removal of asymmetric information in contracts and the avoidance of risk-taking; (iii) the exclusion of financing and dealing in activities and commodities regarded as sinful or socially irresponsible (such as gambling, alcohol and pork); (iv) an emphasis on risk-sharing, the provider of financial funds and the entrepreneur share business risk in return for a pre-determined share of profits and losses; (v) the desirability of materiality, a financial transaction needs to have 'material

finality', that is a direct or indirect link to a real economic transaction; and (vi) consideration of justice, a financial transaction should not lead to the exploitation of any party to the transaction. (El-Gamal 2000; Obaidullah 2005; and Butt et al, 2011).

Hashim (2006), acknowledged that most people join *takaful* due to the existence of an Islamic compliance system and the *takaful* operation which most of the Muslim respondents were highly concerned with. The Islamic banking institutions are of the view that *sharia'ah* compliance is a key element in consumer's attitude towards Islamic bank and any recurrent violations will result in ungratified consumers. *Takaful* is an Islamic insurance which serve the needs of Muslims and non- Muslims who need ethical insurance same as that of Islamic bank. In view of the above and from the literatures reviewed, it could be stated that customer perception on both service quality and product quality is important because it is linked to awareness and religion is behind the reason for majority of Muslims' patronage (Gait and Worthington, 2008).

2.7 An Overview of *Takaful* in Nigeria

The concept of Islamic insurance "*takaful*" is directly from the source of Islamic law and its primary aim is to serve as alternative to the *shari'ah* prohibited form of conventional insurance. it has been affirmed the global *takaful* contributions rose to 19 per cent in 2010 which amounts to \$8.3 billion and was expected to rise higher. This provides opportunity for development and growth of Non-Interest Financial Institutions (NIFIs) in Nigeria (Ernst & Young UK 2012) cited in (Yusuf, 2012).

Kollere (2014), states that financial exclusion has given much impetus for the development of suitable financial products. And *Takaful* (Islamic Insurance) is been operated by three companies in Nigeria, namely, African Alliance Insurance Company Limited, followed by Niger Insurance Plc and Cornerstone Insurance Plc.

According to Dewa (undated) in The Introduction to *Takaful* in Nigeria and Darazo (2011), the viability of *takaful* in Nigeria is based on three factors, one, the high rate of Muslims as of the population, second the establishment of *Shari'ah* law in Muslim populated area and third the recognition of *Shari'ah* legal system in its constitution and challenges conventional insurance market has been facing that lead to low patronage of insurance in the market. In this regard, the National Insurance

Commission (NAICOM) issued license to Cornerstone Insurance Plc, African Alliance Insurance Plc and Niger Insurance Plc to operate Islamic insurance in order to pave way for citizens who needed ethical financing. However, out of the three companies allowed operats *Takaful* only Cornerstone created a separate *takaful* office which is being run by one of its subsidiaries *Halal takaful* Nigeria, where assets of *takaful* are separated from that of the conventional insurance funds.

EFINA report of (2012) as cited by Darazo (2011), view that only 1.5% of the total population of Nigeria have insurance covers and insurance penetration in Nigeria is less than 1% as compared to some Africa countries and he further explained that if low patronage of conventional insurance can be explained as negative perception, lack of claim settlement including several reason than the unpopularity of *takaful* business in Nigeria is difficult to explain considering the fact that Nigeria has the second largest Muslim population in Africa and the rapid expansion of Islamic insurance business around the globe. This includes countries with lower wealth indicators and Muslim population compared to Nigeria. Bello and Ayub (2012), assent that not much progress on *takaful* penetration has been recorded in the Northern part of Nigeria. Despite *takaful* being in existence and legalized to operate in Nigerian not much progress has been recorded unlike Malaysia where the performance of *takaful* have contributed tremendously to the development of the Malaysian economy.

AL- Ghazali and (Chapra, 1985:33), as cited in Dandago (2012), "the objective of Shari'ah is to promote the welfare of the people by safeguarding their faith, life, intellect, property and posterity", *Takaful* serve as an Islamic insurance based on solidarity and brotherhood assistance which indicated that the concept is along with the principle of Islamic law.

Haiss and Sumegi, (1999) as cited in Yusuf (2012), explained that Insurance companies, together with mutual and pension funds, are some of the biggest institutional investors into stock markets and their impact on the economic development will grow due to issues such as ageing societies, widening income disparity and globalization. This trend is likely to be accelerated with the new foray of Islamic insurance (*takaful*) into the economic space by essentially targeting a sizeable mass of low-income earners. It could be deuced from the above that there are existing challenges facing the growth of *takaful* in Nigeria.

3.1 Statement of Approach

This study focused on the determinants of motor *takaful* products and services patronage among commercial vehicle users. From the literature reviewed it is clear that service quality, benefits, promotion, products, features and religion play significant roles in determining motor *takaful* patronage among commercial vehicles owners. But the question is: do these factors play significant role in determining patronage to *takaful* among motor vehicle operators? The study is a preliminary survey of the opinions of some few motor vehicle users in Kano metropolis, who were asked questions on what they would do if *takaful* opportunities are offered to them as a way of owning vehicle for use as participants. The responses received led to the analysis and conclusions reached, which opens way for more comprehensive research work on the subject matter.

4.1 Result of Preliminary Survey and Discussions

Zin et al (2008) observed that although *takaful* is a recent phenomenon, it has witnessed significant growth in Malaysia, after thirteen (13) years of existence. Rahman, *et .al.* (2008) A comparative study between auto *takaful* and auto insurance purchasing behavior among Malaysian undergraduate. The main purpose of their study is to understand their choices and perception towards the determinants of selection. A survey of 537 undergraduate were selected and it was found that majority choose auto insurance over auto *takaful* due to some factor influence such as service delivery, service provision, reputation electronic service and convenience but base on religion it was found out that auto *takaful* was rank higher the study enlighten that there is high tendency for the respondent to renew with auto *takaful*.

In the study of general *Takaful*, Hamid, Osman & Nordin (2009), investigate the factors or determinants of corporate demand for *takaful* products in Malaysia. They have measured explanatory variables which are: Leverage, growth opportunities, expected bankruptcy costs, company size, managerial ownership tax considerations and regulation effects; in determining the corporate demand for Islamic insurance in Malaysia, (as dependent variables). Their findings have shown that all the explanatory variables have important role for determining the *Takaful* demand in Malaysia. Another study of Hamid & Othman (2009), examined the level of knowledge and understanding with regard to *takaful* business among Muslims in Malaysia to meet these, level of awareness in the existence of *takaful* and participation in the *takaful* products among the respondents was test and address, the findings show the majority of the respondents agreed to use *takaful* products. It is found that the most

reason of accepting the use of *Shariah* terms is to differentiate the *takaful* from conventional insurance and to demonstrate that *takaful* promotes the Islamic finance products. In addition the majority of the respondents did not know/ understand *tabarru*. Moreover, about 68 percent and 62 percent of the respondents did not understand the elements of *gharar* and *maysir* respectively.

Abdul Aziz, Mat & Wok zin (2011), examined the level of civil servants perception toward motor *takaful* in Dungun Terengganu, Malaysia. The research focus on four factors which are knowledge, awareness, advertising and benefit. To meet these, 300 respondents were selected through a convenience sampling procedure. The data was analyzed using multiple regression and Pearson correlation where the finding shows that there is a strong relationship between knowledge, awareness, advertisement and benefit toward the perception of motor *takaful*.

Ayinde and Echchabi (2012) reviewed the perception and adoption of Islamic insurance in Malaysia. The objective of the research is to explore willingness of Malaysian customer to adopt Islamic insurance and determine the variables such as uncertainty, related advantage, compatibility, social influence and awareness that influence it. 200 copies of questionnaire were administered and data were analyze using structural equation model and t- test based on the findings it was revealed that compatibility and awareness are factors that influence customer decision to select Islamic insurance.

Bello and Ayub (2014) conducted a research on perception of consumers (income earners) on Islamic insurance (*takaful*) service's consumption in Kano Metropolis, Nigeria. The study aims at examining some factors that explain favorable consumers' perception on Islamic insurance (*Takaful*) services consumptions, where it used judgmental sampling techniques to test two different dimensions: awareness and income earners' trust and confidence. A total sample of 384 of questionnaire was distributed and the use of multiple regression analysis was conducted to investigate how well awareness and trust cause perception. In their findings it was observed that lack of knowledge/ information of consumer perception create gap between the needs of consumers and the services providers offers in the market. Their findings it also indicate that, socio - economic factor is significant in predicting consumers' perception while awareness level and

level of trust are significant in predicting consumers' perception of *takaful* service.

It could be said that not much study has been conducted on determinant of motor *takaful* patronage. Researches specifically on determinant of motor *takaful* patronage among commercial vehicle owners have not been conducted in Nigeria. This makes the study empirical and it requires other researchers to conduct further studies in order to shed more light on *takaful* product and services in Nigeria.

5.1 Conclusions, Recommendations and Limitation

The study embarks on determinant of motor *takaful* patronage among commercial vehicle operators. It reveals that Service quality, promotion, benefit, product, feature and religion are sufficient tools that could be used to enhance patronage of *takaful*. It was confirmed that Muslims patronize Islamic insurance based on their religion belief but are also keen on service quality and benefits to be derived from it. This present study shows how significant these factors could serve as mechanism to *takaful* companies to enhance patronage of motor *takaful*.

Hence, it is recommended that Islamic insurance need to potentially explore various strategies to offer quality services for consumers to develop public positive attitude which will serve as the bases to encourage people's willingness to patronize the motor *takaful* services.

As an Islamic insurance company which operates in accordance with the principles of Shari'ah, it should focus on making some modifications on the product and feature of *takaful* services that differs from its counterpart so that consumers can visualize its benefits and the necessity in solving the daily risks exposure.

In term of promotion, it has been known as a vital tool for an organization mostly when new products or services are introduced in the market. *Takaful* operators should increase the promotion strategies to enhance the level of the public awareness. *Takaful* operators should aggressively use this tool in order to reach the segmented market if they wish to get more customers to subscribe and become policyholders of the Motor Islamic insurance policies among the society which is in accordance to the *Shari'ah* principles.

The study has limitation that should be taken into account in the future studies, the issues of challenges facing *takaful* motor industry was not reviewed. It is recommended for future research work to carry out study on the aspect of challenges facing motor *takaful* product and services.

References

Abdul Aziz, W.A.W., Mat, A.C. and Zin, E. A. M. (2011). "A Study of Contributing Factors in Islamic Motor Insurance," *Gaziantep University Journal of Social Science*, 10, pp.1-20.

Alhumodi, Y.A. (2012). "Islamic Insurance (*Takaful*) and its Application in Saudi Arabia," A thesis submitted for degree of doctor philosophy, Brunel University.

Ali, K. M. M. (2009). *Basis and Models of Takaful: The need for Ijtihad*. ICMIF Series of Takaful articles 3:1-5.

Anwar, H. (2008). *Islamic Finance: A Guide for International Business and Investment*. G M B Publication Ltd, United Kingdom.

Amin, H. & Abdulrahman, A. M. (2011). Determinants of Intention to use Islamic personal Financing, *Journal of Islamic Accounting and Business Research*, 2(1), 22-40

Arbouna, M.B.(2000). The Operation of Re-*takaful* (Islamic Reinsurance) Protection. *Arab Law Quarterly* 15 (4): 335-362.

Awang I. and Zakariah, S. (2009). "The Conception and Response of Muslims Community to

Takaful Scheme”,: A case study of Bagan Serai, Perak. *Journal fiqh*,2,1-18.

Awon, A, & Azhar, M. (2014). Consumer Behavior Towards Islamic Banking in Pakistan.

European Journal of Accounting Auditing and Finance Research, 2(9), 42-65

Ayinde, O. L., & Echchabi, A. (2012). Perception and Adoption of Islamic Insurance in

Malaysia: “An Empirical study” World Applied Science Journal, 20(3), 407-415 Aziz, W.A.B.W.A., Mat, A.C. and Zin, E. A. M. E.(2011).“A Study of Contributing Factors in Islamic Motor Insurance,” Gaziantep University Journal of Social Science, 10, pp.1-20.

Bashir, S. M. (2012). Awareness, Service quality and Product effect on Satisfaction of Islamic

Banking in Brunei, Darussalam. 2nd International conference of Management Proceeding, Retrieved on April 20th on line at <http://etd.Uum.edu.my/4137/13/5813574-abstract.pdf>

Bashir, S. M. (). Analysis of Customer Satisfaction with the Islamic Banking Section .Case

study of Brunei: Darussalam, Asian. Journal of Business and Management Science, 2(10), 38-50

Bello, B. G & Ayuba, H. (2014).Perception of Consumers (Income-Earners) on Islamic

Insurance (*Takaful*) Services Consumption in Kano. A Paper Presented at the 1st International Conference of the International Institute of Islamic Banking and Finance, Bayero University Kano, Nigeria.

Billah, M. (2003), Principle and Practices of *Takaful* and *Retakaful*. Retrieved on 10th October

from <http://www.islamic-insurance.com>, IIUM Press, KL, 51.

Bitner, M. J. (2001). Service and Technology: Opportunities and Paradoxes. *Management*

services quality, 11(6), 375-379

Butt, I., Ahmad, H., Altaf, M., Jaffer, K. & Mohammad, J. (2011). Barriers to Adoption of

Islamic Islamic Banking in Pakistan, *Journal of Islamic Markrt*, 2(3), 259-273

Dandago, K. I. (2012). "TAKAFUL" (Islamic Insurance): Historical background,

Misconception, challenges and Products, *Islamic Economics: A Book of Readings*, The International Institute of Islamic Thought Nigeria Office (IIIT). ISBN: 978-978-927-978-4.

Darazo, Z.S. (2011). *Takaful Insurance Implementation: A Drive Towards an Inclusive Insurance*

sectors in Nigeria. National Insurance commission of Nigeria.

Dewa, N (undated). "Implications of the introduction of the Islamic Banking system and Takaful

Insurance system and practice in Nigeria. Accessed on December 15th (2014). from <http://www.academia.edu/5539219/THE-INTRODUCTION-OF-TAKAFUL-IN-NIGERIA-09132013>.

El- Gamal, M. A. (2000). *A Basic Guide to Contemporary Islamic Banking and Finance*.

Available online at web – site: <http://www.nubank.com/Islamic/primer.pdf>. Retrieved on 17th April, 2015

Fisher, O & Taylor, D. (2000). Prospect for Evolution of Takaful in the 21st Century. Fellows

and president University, Mass. USA.

Gait, A., & Worthington, A. (2008). An Empirical Survey of Individual Consumer, Business

firm and Finance Institution Attitude towards Islamic methods of Finance. International Journal of Social Economic, 35(11), 783- 808 available online at <http://dx.do:org/10.1108/0306829081095423>.

Hamid, M.A., & thman M.S. (2009). Study on the level of Knowledge and Understanding

among Muslims towards the concepts, Arabic and *Sharia'h* terms in Islamic Insurance (*Takaful*). European Journal of Social Science, 10(3), 468-478.

Hassan, A. S., Subhani, I. M., & Osman, A. M. (2012). Consumer Criteria for the selection of an

Islamic Bank: Evidence from Pakistan. Available online at [http://mpra.ub.uni-muenchen.de/40384/MPRA paper \(4\)](http://mpra.ub.uni-muenchen.de/40384/MPRA%20paper%20(4))

Idirs. R. A., Naziman, M. N. K., Janur, S. S. Asari, H. A. F. F., Muhammad, N., Sabir. MD. S. & Jusofl, K. (2011) Religious value as the main influence factor to customer patronizing

Islamic Bank. Special Issues on Blotering Economic Sustainability. Publishes, 2011 World Applied Science Journal (12)

Institute of Islamic Banking and Insurance (2012). '*Sharia'ah* Supervisory Board': (SAB).

Access from <http://www.islamic-banking.com/takaful-shariah-supervisory-board.aspxv.htm>. Accessed 10th November, 2014

Ismail, E. (2011). Basic *Takaful* Broking Hand book: Course Manual for Basic Certification

Course in Takaful Broking (BCCTB).

Islamic Financial System (2012). Principle and Operation, published by Intentional *Shari'ah* Research Academy for Islamic Finance (ISRA). Kuala Lumpur, Malaysia.

Kauffman, F. (2015). Product/service features and Benefit. Available at <http://www.enterepreneurship.org/research-center/product> service features and Benefit.

Retrieved on April 18th 2015.

Kollere, U. A. (2015). Takaful Insurance Vs Conventional Insurance. In Nigeria. Available

online at http://www.Leadership.ng/business/378443/takaful_Insurance_vs_conventional_Insurane. Retrieved on April 19th (2015).

Magnus, S. & Mats, O. (1999). Customer Satisfaction and links to Customer Profitability. An Empirical Examination of the Association between Attitude and Behavior, Available

online at <http://www.researchgate.net/profitmagnus-soederlud/publication/2353171285>

predicting-purchasing.

Marhanum, C. M. S., Abdullah, I. W. N & Razali, S. S. (2013). Measuring Takaful Agent

Understands toward the Objective and Concept of Takaful. Journal of Islamic finance, 2(1) IIUM Institute of Islamic Banking and Finance

Maizaitucaidawat, MD.H., & Asmak, Ab. R. (2011) The Role of Brand in Malaysian Takaful

Industry. Journal Teknologi, <http://www.jurnalteknologi.utm.my/index.php/jurnalteknologi/article/view/1358>. Retrieved on 18th April, 2015

Matasawali, M. S., Abdullah, F. M., Siti, Y. C. P., Abidin, Y., Masanllza, M. Z., Hardi M. A., Alani, F. & Yaacob, H. (2012). "A study on *Takaful* and Conventional Islamic Preference," the case of Brunei, *International Journal of Business and Social Science*.3(22).

Maysami, R.C. and Kwon, W.J.(1999). An Analysis of Islamic *Takaful* Insurance – A

Cooperative Insurance Mechanism. *Journal Insurance Regulation*, 18: 109- 132.

Obaidullah, M. (2005). Islamic financial services. Islamic Economics research Center, King

Abdul Aziz University, Jeddah. <http://www.iiste.org/journals/index.php/EJBM/article/view>. Retrieved on 17th April, 2015

Parasuraman, A., Zeithaml, V.A. and Berry, L.L. (1988). SERVQUAL: a multiple-item scale for measuring consumer perceptions of service quality. *Journal of Retailing*, 64(1),

Rahman, A., Ali, A. N., Seman, C. & Ahmad, W. M. (2008). Comparative Study Between Auto *Takaful* and Auto Insurance Purchasing behavior among Malaysia Undergraduate. *Shari'ah Journal*, 16(1), 75- 88.

Swartez, N. & Coetzer, P. (2010). *Takaful*: An Islamic Insurance Instrument. *Jouranal of Development and Agricultural Economic*. 2(10) 333-339 available online at

htt://www.academic journals.org /JDAE ISSN 2000 – 9774@ Academic journal.

Tiwari, S. P., Chandhok, A., Chauhan, K. A., Sambhanvna, Gupta, K. M., Chawla, V. Deene,

S.(2011), The International of Research in Commerce, Economics, and Management Sicence. 2(10), 38- 50

Siddiqi, M. N (1985). Insurance in an Islamic Economy, Nairobi, Kenya: Islamic

Foundation. available online at

<http://.wikipedia.org/wiki/mohammad-Najatuallah-sissiqi>,

Retrieved on April 19th 2015

Sabbagh, A. M. (2012). Islamic Takaful Insurance from Jurisprudents to Application: The Insurance Company Islamic Amman–Jordan.

<http://www.islamicinsurance.jo/wp>

content/uploads/2013/07/ISLAMIC-TAKAFUL-INSURANCE-2-ok-fienal.pdf

Yusof, M. F. (1996).The Concept and Operational System of *Takaul* Business. New Horizon pp:

10-14.

Yusuf, T.O. (2012). Prospects of *Takaful* (Islamic Insurance) Contribution to the Nigerian Economy. Journal of Financial and Investment Analysis, vol.1, No.3, 217-230 ISSW:

2211-0988.(Print Version)

Takaful Brunei Darussalam (2011). The Meaning of Takaful. Retrieved from

<http://www.takaful.brunei.com.bn/corporate/about-takaful>, Accessed October (2014).

Rahman, S. M., Abdulfattah, A. F. & Mohammad, B. O.(2014). Service Quality and Customers'

Patronage Decision of Healthcare Insurance Product: In-Depth Interview Approach. International Journal of Academic Research and Social Science 4(7)

Rahman, A., Ali, A. N., Seman, C. & Ahmad, W. M. (2008). Comparative Study Between Auto

Takaful and Auto Insurance Purchasing behavior among Malaysia Undergraduate. Shari'ah Journal, 16(1), 75- 88.

Razak, M. I. M.D, Idris, R., Yusof, M. M D, Jaapar, W. E., & Ali, M.N. (2013). Acceptance

Determinants towards Takaful Product in Malaysia: International Journal of Humanities and Social Science 3(17).

CORPORATE REPORTING

ENVIRONMENTAL ACCOUNTING PRACTICE; BENEFITS, CHALLENGES AND THE WAY FORWARD – Afrogha, O. O.

Abstract

Environmental accounting is fast becoming a necessary complement for improved financial reporting and decision making within organisations. However, there seems to be an apparent lack of awareness and understanding of the opportunities for cost reduction through proper environmental accounting. The purpose of this study is to examine the impact of environmental accounting, review the challenges and benefits of reporting organizational performance with particular reference to oil and gas companies operating in the Nigeria. The study is based on primary and secondary data gathered from interviews and Annual Report of the companies. The study highlights achievements of environmental accounting, amongst the findings of the study are that; there is the need for a framework on environmental accounting and accounting professionals need to be trained on environmental accounting methods. The study recommends that; organisations should adopt a uniform method of reporting and disclose environmental issues for the purpose of control and measurement of performance. Similarly, accounting standards should be published locally and internationally and reviewed continually to ensure dynamism and compliance to meet environmental and situational needs.

Keywords: Environmental accounting, Environmental reporting, oil and gas companies, Organisations.

INTRODUCTION

There is an increased demand by stakeholders for organisations to minimize their environmental impact and reduce costs. Environmental impacts are not limited to Nigeria as they are also international (Afzal 2012). Nigeria is gradually facing the challenge of a degrading environment and unfortunately this has left Nigeria with a large economic, social and environmental legacy. Conversely, not many studies have been carried out on environmental accounting in the context of Nigeria. Also, the enforcement of compliance with laws, guidelines, policies and standards on environmental matters is in question (Daferighe, 2012). Thus, there is the tendency for companies to relocate to developing countries where the environmental requirements which they have to meet are not as strict as those for other countries.

Environmental Accounting is the process of identification, measurement and allocation of environmental costs, the interaction of these costs into business, identifying environmental liabilities if any and finally communicating this information to stakeholders as a part of general purpose financial statement United States Environment Protection Agency (USEPA) (1995).

Consequent upon this understanding, the concern for the environment has been repeatedly expressed over the years in a series of international summits and conferences like the United Nations Conference on Human Development, 1997 Kyoto Protocol, Global Initiative for Gas Flaring Reduction 2007, Bali Declaration and lately the Copenhagen Conference 2009, amongst others. Although, for most developed countries of the world, environmental accounting and reporting has developed voluntarily (Uwalomwa & Uadiale, 2011), however, this is not the same in developing countries (Azzone, Manzini & Noci, 1996). Nigeria is not an exception amongst countries paying lip-service to issues of environmental pollutions as demonstrated by successive extension of gas flaring deadline many times in 2004, 2007, 2008, 2010, 2012 and lately the extension beyond 2015 as the terminal date for gas flaring by the legislative, hence the need for a reporting framework for proper environmental accounting.

Stakeholders such as; Government, Investors, Customers and Local communities require organisations to improve and report environmental performance. This is because environmental costs are not matching with its earnings and benefits which are a critical part of decision making. In addition, conventional accounting practice does not provide sufficient and accurate information for environmental cost management. As a result, most organisations have not fully understood the costs and benefits associated with proper environmental accounting. This paper therefore

assesses the benefits and challenges of environmental and how improved environmental accounting reporting can reduce cost for organisations.

STATEMENT OF PROBLEM

It is pertinent to note that not many studies have been carried out on environmental accounting in developing countries. (Tsang, 1998) in a study of 33 listed companies in Singapore based on data years 1986 to 1995, noted that only (17) 52% of the companies made environmental disclosures in the 1980s and then a stable pattern was seen from 1993. This may be attributed to the lack of understanding, benefits of environmental accounting and the voluntary nature of disclosures during the period. Conversely, (Kisenyi & Gray, 1998) in a study of four companies in Uganda observed that none of them carried out any environmental accounting with no environmental disclosures. Thus, they conclude that social and environmental disclosure in Uganda is scarce and is shown little importance.

In Nigeria a study carried out by (Disu & Gray, 1998) between 1994 and 1995 on 22 large multinational companies found out that less than a quarter of companies made disclosures on environmental accounting. This may be as a result of lack of emphasis on environmental accounting and limited pressure from stakeholders during the period. Thus, once the companies attained a certain level of disclosure, there was no motivation to go further. Consequently, many organisations under-estimate the cost savings of proper disclosure and benefits to the organisation of environmental accounting. From the Nigerian context, the study made by (Disu & Gray, 1998) is getting out of date as it is now 20 years old. It is felt that more recent studies are needed to examine environmental accounting practice, benefits and challenges to know the current practice of companies in Nigeria.

As analysed above and even with the dynamic nature of the business environment it is imperative to understand the way in which businesses have measured up to ensure environmental accounting and reporting. Against this backdrop, the benefits and challenges of environmental accounting and reporting in the Nigerian Oil and Gas industry would be investigated in this study to determine whether understanding of the benefits and challenges of environmental accounting would help improve environmental reporting.

OBJECTIVE OF THE STUDY

The following objectives are proposed for this paper:

- To examine environmental accounting and reporting in the Nigerian Oil and Gas Industry.
- To identify challenges involved in environmental accounting in the Nigerian Oil and Gas Industry.
- To identify benefits of environmental accounting in the Nigerian Oil and Gas Industry.
- To recommend measures on the way forward for environmental accounting in Nigeria.

REVIEW OF RELEVANT LITERATURE

The environment is becoming an urgent economic, social and political problem across the globe, based on the problem of promoting economic development and protecting the environment (Tsang, 1998). Thus, there is urgent need for a balance between development and environmental protection. Consequently, a careful assessment of environmental costs and benefits is necessary to find the tolerance limit of environmental degradation and required level of development. However, without proper environmental accounting and reporting, it is difficult to determine whether organisations are fulfilling their responsibilities.

Organisations have experienced significant changes in the 21st century ranging from increased globalisation, changing business environment, unstable demand and prices to government policies on carbon emission. These require organisations to plan effectively and efficiently to maximise profits as an increased number of stakeholders are requesting for increased responsibility for the environment by organisations. Similarly, for increased success in the oil and gas industry there is need for a successful relationship between stakeholders. This is supported by (Cox, 2008) who stated that traditionally the oil and gas industry has focused on cost saving strategies.

More so, Environmental accounting has continued to grow along the lines of financial accounting and addressing disclosure practices (Llena, Moneva & Ortas, 2007). Although statutory accounting and reporting are covered by generally acceptable principles and reporting standards as it relates to different countries. (Sarmiento, Durao & Duarte, 2005) noted that accounting standards are yet to internalize costs and expenses outside the boundaries of financial accounting.

Environmental accounting could be seen to provide information to stakeholders on environmental impact which aides in their decision making. According to (Daferighe,2012) Environmental accounting is a subset of accounting that aims to incorporate both economic and

environmental information. Environmental accounting identifies measures and communicates costs from an organisation's actual or potential impact on the environment. These costs include but are not limited to; costs to clean up or remedy contaminated sites, environmental fines, penalties, taxes and waste management costs. Laitner (2002) noted that these costs can be reduced through the implementation of more energy efficient practices which reduce waste and ensure more efficient disposal.

Thus, environmental accounting is a necessary tool in comprehending the role played by the natural environment in the economy and the measurement of environmental performance.

According to the Environmental Agency United Kingdom (EAUK) (2006), Environmental Accounting is defined as the collection, analysis and assessment of environmental and financial performance data obtained from business management information systems such as; environmental management and financial accounting systems.

However, lack of awareness and due care of the environment leading to environmental damages have resulted in increasing pressures by stakeholders for environmental disclosures by organisations. The absence of which, may alter stakeholders opinion of companies and lead to loss of business (Welford 1998). Consequently, companies that demonstrate environmental concern and include the impact of environmental factors in their business plan can attain improved image, competitiveness, and win favour with stakeholders (Schaltegger, Burritt & Peterson, 2003). Studies conducted by (Hamschmidt & Dyllick, 2001) noted that some companies complain that the benefits of environmental accounting take long time to manifest though in the short run there can be financial outlay to establish certain environmental improvements.

However, in most organisations the balance of costs and benefits of environmental accounting remains unrealised because companies have not recorded or analysed information on environmental accounting. This may be attributed to difficulties in determining the benefits of environmental accounting, lack of trained accounting professionals in the aspect of environmental accounting and environmental management systems which may not have been in use for a long period of time in order to provide full sets of data.

Environmental reporting on the other hand according to the United States Environment Protection Agency (USEPA) (1995) is the disclosure of information relating to an organisations environmental effects and its contribution to sustainable development. This disclosure could be in the form of a separate environmental report or included in the annual report of entities. Studies by (Daferighe, 2010) observed that there is the

tendency for companies to relocate to developing countries where conditions for environmental reporting are not as strict as other countries and not much emphasis is placed on environmental accounting.

However, the growing recognition of the importance of transparency for economic growth and social development has led to calls from civil society and a broader range of stakeholders for greater transparency and accountability to aid decision making (Reynolds & Reynolds 2010).

However, the existing environmental and social accounting literature like (Harte & Owen, 1991), (Bewley & Li, 2000), (Ahmed & Sulaiman, 2004), (Thomson & Zakarai, 2004) (Halil & Seda, 2014), identified that still environmental reporting is very low and mere narrative disclosure. Environmental accounting and reporting needs to be given increased attention as it is relevant to: Investors, Governments, Communities, Competition, Contractors, and Environmental groups and important for risk management. This can be achieved through the improved role of Accountants in performance measurement and evaluation, auditing and reporting skills on environmental management and reporting. Accountability can be portrayed to stakeholders through reporting. Thus, if environmental accounting is the requirement to form a common basis for internal and external users of the environment, the effective channel is environmental reporting (Bebbington, 1997).

The United States Environmental Protection Agency (USEPA 1995) has mentioned that an important function of environmental accounting is to bring environmental costs to the attention of corporate stakeholders who may be able to identify ways of reducing or avoiding those costs, while at the same time, improving the environmental quality. Therefore, the implementation of environmental accounting can help to achieve the objective of corporations and other stakeholders in reducing the costs and decreasing the pollution respectively.

Studies by (Daferighe, 2012) noted that environmental accounting is an important tool for understanding the role played by the natural environment in the society. Environmental accounts provide data which bring to light the contribution of natural resources to economic well-being and the costs that arise as a result of pollution or resource degradation. Environmental accounting is on expansion path with increasing social focus on the environment; and environmental accounting fills an expectation role to measure environmental performance.

Three different theories have been identified in literature on environmental reporting; the stakeholder theory, legitimacy theory and the social contract theory. (Lee & Lings, 2008) noted that the theoretical framework aides in better understanding of what is obtainable in the real

world. These theories take a system perspective, recognizing that businesses interact with and affect entities beyond their artificial boundaries. (Gray, Kouhy & Lavers, 1995) argued that these theories should not be seen as a competitive explanation but as a source of interpretation of different factors at different levels of resolution.

Legitimacy theory

This theory relates to the extent and types of corporate social disclosure in the annual report to be directly related to management's perceptions about the concerns of the community. This position is supported by (Gray, Kouhy & Lavers, 1995) who suggest that legitimacy theory is useful in analyzing corporate behaviour. The legitimacy theory argues that organisations seek to ensure that they operate within the bounds and norms of society (Tilt, 1999). Similarly, studies by (Tinker & Niemark, 1987) noted that society's expectations have changed to expect businesses to make outlays to repair or prevent damage to the physical environment, to ensure the health and safety of consumers, employees, and those who reside in the communities where products are manufactured and wastes are dumped. To this end, organisations attempt to establish congruence between the social values associated with or implied by their activities and the norms of acceptable behaviour in the larger social system of which they are part.

Stakeholder theory

This theory according to (Watts & Zimmerman, 1978) assumes that disclosure on social and environmental information by an organisation is as a result of the pressure from stakeholders such as communities, customers, employees, environment, shareholders and suppliers. The basic proposition of this stakeholder theory is that a firm's success is dependent upon the successful management of all the relationships that a firm has with its stakeholders. These stakeholders include but are not limited to; Investors, Governments, Communities, Competition, Contractors, and Environmental groups.

Social contract theory

This theory, which was developed, based on concept that there exists contract between business and wider society, whereby business agrees to perform various society desired actions in return for approval of its objectives, other rewards and its ultimate survival (Guthrie & Parker, 1989).

However, while legitimacy theory has become the most widely used theory to explain corporate social environmental disclosure practices (Campbell, 2003: Deegan, 2002) as there is mounting evidence that

managers adopt legitimizing strategies, the same cannot be said of the stakeholder theory especially in developing countries like Nigeria where environmental crisis and civil unrest in the Niger-Delta has crippled industrial activities in the area. To this end therefore, this study adopts the stakeholders' theory as a basis in explaining environmental accounting and reporting.

The environment is considered to be in a moral par with humans. (Welford, 1996) noted that protecting the environment involves meeting the need of both current and future generations. Similarly, environmental accounting has different dimensions (Grinnel & Hunt, 2000). First, is the need to position environmental policy in the overall business policy and strategy; second are the disciplines involved in producing environmental accounts and their reporting; and third is the environmental requirement to assure compliance with environmental accounting regulation. Thus, environmental accounts are essential for managers as well as policy makers at the varying levels of governance for decision making and identifying ways of reducing cost. Studies by (Daferighe, 2012) on environmental accounting and degradation noted that a country like Nigeria which is mainly dependent on petroleum can only be economically stable if revenue from petroleum exploration is transformed into alternative assets. Thus, with environmental accounting, managers and policy makers can monitor this process. This will in turn provide a sound basis for policy interventions which are consistent with sustainable development at each stage.

The United States Environmental Protection Agency (USEPA,1995) and the Environmental Agency United Kingdom (2006) identify possible benefits for organisations that consider adopting environmental accounting as;

1. Possible significant reduction or elimination of costs.
2. Possible revenue generation which may offset environmental costs.
3. More accurate costing and environmentally desired process.
4. Provides better estimates to a firm of true cost to the firm of producing a product.
5. Assists mangers in targeting cost reduction and improving environmental quality.
6. Encourages changes in processes to reduce waste, reduce resource use recycle waste or identify markets for wastes.

However, research reveal that conventional accounting allocate environmental costs to general overhead accounts with the consequence that products and production managers have no incentive to reduce environmental costs and top management is often not aware of the extent of these costs (De beer and Friend 2002; Gale 2006). According to

(Deegan, 2002) majority of cost accounting systems within organisations pay little attention or no attention to attributing any form of environmental cost to organisations operations. This is seen in many environmental costs been accumulated in overhead accounts. (Scavone, 2006: Gale 2006)

The existing literature on environmental accounting gives enough evidence that though environmental accounting and reporting has started gaining awareness but it is yet to be developed as desired by stakeholders. Therefore, it is important to find out the challenges faced in sound development of environment accounting and reporting practices.

Research Methodology

The primary purpose for this paper is to examine the benefits and challenges of environmental accounting practice and recommend ways of improvement. The study focuses on oil and gas companies in the upstream sector of the Nigerian Petroleum industry. For the purpose of this study, the inductive approach has been adopted. According to Strauss and (Cobin, 1990) the inductive approach aides the researcher to discover and comprehend the reason behind a phenomenon about which there is limited information available.

Furthermore, the qualitative method has been adopted to help the researcher gather more data. (Ritchie & Lewis, 2008) stated that a qualitative approach can be applied to understand a social phenomenon. The use of the qualitative method is based on the researcher's adoption of semi-structured interviews for data collection and limited literature available on environmental accounting in the oil and gas industry in Nigeria. Three case organisations in the upstream oil and gas industry have been selected for this research and a holistic view will be adopted.

The sample size chosen is influenced by the objectives of the study and was chosen in order to limit the constraints of time, cost, availability of reports and access to companies. The targeted respondents are management personnel in the different companies. These people have worked with the companies from periods ranging between 8 to 15 years and have been successful in their careers. This implies that they are most likely to offer insights from which understanding of environmental accounting benefits and challenges in the Nigerian oil and gas industry can be built on. Primary data for this research has been gathered through semi structured interviews conducted with management personnel of the three companies personnel based on conditions of anonymity of the respondents and company names. The researcher was able to observe patterns based on information supplied by the various respondents to help analyse data used in the study. Secondary data was also adopted in this study; this was sourced from the annual report of selected

companies. (Gray, Kouhy & Lavers, 1995) and (Adams, 2004) noted that there are different ways environmental accounting reporting may be made. This study makes use of disclosures in annual reports of the companies.

DATA ANALYSIS

The data for the purpose of this study was obtained through secondary sources and interviews as noted above. The researcher conducted a total number of three interviews. These interviews were analysed by transcribing the conversations into writing and observing the pattern. In order to maintain anonymity and for ethical reasons the respondents have been tagged as IX, IY and IZ in presenting the data obtained.

The questions asked during the interview were divided into sections in order to address the objectives of the study. The answers from the respondents to the interview questions provided the researcher with information to address the aim of the research which is to “examine the benefits and challenges of environmental accounting in Nigeria and recommend ways for improvement.”

The introductory part of the interview was a background inquiry of the interviewee. Questions such as the number of years worked, position occupied by the interviewee in their organisation was asked. This was to ascertain the originality and reliability of data provided by the interviewees.

The questions in section A were targeted at obtaining information on the knowledge of environmental accounting and whether it is seen as useful for the company. The questions in section B focused on the state of environmental accounting within the organisation in order to address the second objective of examining the state of environmental accounting. The questions in this section were aimed at determining the problems faced by the organisation in terms of environmental accounting. The aim of the questions in section C was to obtain information on the benefits and challenges faced by the organisation in environmental accounting in order to address the third and fourth objectives of the study.

A. The Need for environmental accounting:

In response to the first objective to examine environmental accounting and development within the organisation, all respondents agreed that environmental accounting is of great importance to the company and could not be neglected in order to achieve operational success. All the respondents from the companies in this study agreed that environmental accounting can help enhance the image of the company to stakeholders. However, they noted that not all information on the company's

environmental activities can be disclosed in the financial statement. This they attributed to the issue of environmentalists or other peace groups who may use such information to gain undue advantage of the company. Thus, environmental accounting serves as a means of enhancing companies' image. The respondents view is in line with the study by (Afzal, 2012) who noted that Environmental Accounting and Reporting (EAR) can uphold the green image of companies.

Also, it was noted based on contributions from two respondents that the level of environmental accounting in the Nigeria oil and gas industry is still at the basic level with one respondent stating that it was at the moderate level within the organisation. The research findings suggest that environmental accounting needs continuous emphasis within most organisations in the oil and gas industry.

Furthermore, from the research findings it was noted that there is the need for a proper framework for environmental accounting in Nigeria. This would help in improved training of account personnel on environmental accounting methods and guidelines. This observation was supported by one of the respondents who noted that the present state of environmental accounting is voluntary rather than mandatory; in such situation companies have tendency to depict the strength rather than the weakness. Another respondent noted that this may be because stakeholders tend to view a company better when it depicts its strength giving it a good image.

B. Benefits of Environmental Accounting

Environmental accounting provides better measurement of the environment's crucial role as both a source of natural capital and as a sink—or repository—for by-products generated during human activities which is important towards the integration of sustainability into economic development (Daferighe, 2012).

In Nigeria environmental accounts can provide policymakers with ecological indicators and descriptive statistics to monitor the environment's contribution to the economy and the economy's impact on the environment.

One of the respondents stated that, environmental accounting aides the discharge of the organization's accountability and increases its environmental transparency before stakeholders. Also, another benefit stated is that environmental accounting can aide organisations and regulatory bodies potentially by serving as a tool for strategic planning and policy analysis to identify the implications of different regulations, taxes, and consumption patterns on environmental sustainability and paths to sustainable development of specific economic activities.

The respondents noted that environmental accounting and reporting would help provide data for auditing to check whether government policies on environmental accounting are successful. This will also serve to check whether companies are in compliance with government regulations. Also, it increases the likelihood of the organisations having a competitive advantage and greater customer acceptance of the firm's product or service when stakeholders are aware of the company engaging in proper environmental accounting.

In addition, environmental accounting encourages changes in processes to reduce waste, reduce resources use, recycle waste or identify markets for waste. This two of the respondents noted is seen in oil and gas companies working towards innovative ways on reducing environmental costs. One of such ways is the reduction of gas flaring and channelling it to the production on of cooking gas as noted by all the respondents.

A careful observation of the Annual Reports of the selected companies for the financial year-2014 reveals the following nature of environmental disclosure in their respective Annual Reports:

1. Only qualitative disclosure of the environmental issues in the nature of descriptive information without their quantification.
2. Presenting positive environmental information ignoring negative information.
3. Some companies have showed environmental information either in the Chairman/ Managing Director's statement or report. Again some other companies have provided environmental information under the caption "Environmental Compliances" separately in their annual reports.

C. Challenges of Environmental Accounting

The respondents note that despite its benefits, environmental accounting is nwithout challenges.

Two respondents stated that In Nigeria there is no adequate environmental accounting framework which can provide guidelines on issues of environmental cost, environmental liability and environmental assets. Thus, capitalisation of such cost and liability and reporting framework creates another challenge. Also, there is wide variation noticed in the style of reporting and theme the companies selected to report. This can add to other dimension of the challenge of lack of comparability and verifiability. However, the integration of such information with financial accounting may give it more reliability.

In addition, one respondent noted that most times environmental information contained in the annual report which is useful for environmental accounting is usually limited. This is seen in companies not stating all their negative impact on the environment to avoid problems

that may arise from environmentalist groups

Most times companies want to minimise costs. However, there are increased costs associated with environmental accounting and these costs cannot be easily identified. One of the respondents noted that although the company has tried to reduce its gas flaring by channelling it to the production of cooking gas. However, the cost of installing equipment to produce cooking gas rather than the gas being flared is more than the revenue generated from the gas produced. This can be a source of discouragement to companies from looking for innovative ways to reduce environmental impact and have improved environmental reporting in company's annual report.

Conclusion and Recommendation

This study has examined the Environmental Accounting Practice in Nigeria, investigating its benefits and challenges. It is encouraging to note that a developing country such as Nigeria, though with challenges can benefit from this area of corporate reporting. Organisations seeking to improve their green image and win stakeholders favour cannot ignore environmental accounting. Hence, it is relevant to organisations in the upstream oil and gas industry.

Policy Implications

Environmental accounting notwithstanding its challenges is important to government and organisations as well. The following recommendations are proposed for improved environmental accounting:

This study indicated that the Companies in the Nigerian upstream Oil and Gas industry have already given much effort in the field of environmental protection. However, the current accounting system does not reflect such efforts for its stakeholders. Thus, companies should work towards showing such activities in their accounts. This would help stakeholders to see results in figures which may be better to reckon with.

The Nigerian Accounting Standards Board (NASB) should work towards having an accounting standard that will have a framework to extend practices to include costing and methods of pollution control; comparing alternative materials to be used, investigating possible recycling alternatives. Similarly, they should develop a standard to guide the practices of Environmental Accounting and Reporting.

Accounting professionals need to be trained in environmental accounting methods and have appropriate guidelines to follow. This would make the basis of comparability across companies easier, where the same methods are adopted.

There is the need for a framework on environmental accounting to include developing guidelines to assist in identification of environmental issues and evaluation and reporting of those issues. This would help to contribute standards for accounting and reporting which will involve developing guidelines to assist identification of environmental issues and evaluation and reporting of those issues.

The Government also has a part to play by improving its enlightenment programme on policies and laws on environmental protection in order to increase awareness amongst organizations operating in the country and citizens. Similarly, Government should support implementation of environmental accounts, indicators and policy analyses based on environmental accounts. It should build sufficient awareness and support for environmental accounting to ensure a more thorough way to compile national accounts. A major focus should be also to influence Multinational and national agencies to mainstream environmental accounting in their programmes. In addition, the National Environmental Standards and Regulations Enforcement Agency (NESREA) should carry out a regular review of the existing regulations where necessary and ensure enforcement and total compliance with these policies and laws.

REFERENCES

- Adams, C. (2004): The ethical, social and environmental reporting-performance portrayal gap. *Accounting, Auditing and Accountability Journal*.17(5), pp. 731–757
- Afzal, A. (2012). Environmental Accounting and Reporting: Significance and Issues: a case from Bangladeshi Companies. *Global Journal of Management and Business Research*.
- Babakri, K. R. Bennett, R.A. Rao, S. and Franchetti, M. 2004. Recycling Performance of Firms Before and After Adoption of ISO 14001 Standards. *Journal of Cleaner Production*, (12) 633-637.
- Bebbington, J. (1997). A review essay on environmental accounting. *Accounting, Auditing and Accountability Journal*. Vol 10(3), pp. 365-376.
- Bebbington, J. and Gray, R. (2001): An account of sustainability: failure, success and a reconceptualization. *Critical Perspectives on Accounting*. 12, pp. 557–587
- Chwastiak, M. and Young, J. J. (2003) "Silences in annual reports", *Critical Perspectives on Accounting* Vol 14, pp. 533-552
- Daferighe, E. E. and Aje, S. O. (2005). "Management of Environmental Accounting System". *International Journal of Economic and Development Issues* Vol.5, No 1&2, pp.204-213.
- De Beer, P. and Friend, F. (2002). Environmental accounting: A Management Tool for Enhancing Corporate Environmental and Economic Performance, Environmental Engineering Group, Department of Chemical Engineering, University of Pretoria, Pretoria.
- Deegan, C. and Rankin, M; (1996) "Do Australian Companies Report Environmental Information Objectively: An Analysis of Environmental Disclosures of Firms

Successfully Prosecuted by the Environment Protection Authority”

Accounting, Auditing, and Accountability Journal, Vol. 9, No. 2 pp. 50-67

Deegan, C. (2002) “Introduction, The legitimising effects of social and environmental

disclosures – a theoretical foundation”, Accounting, Auditing and

Accountability Journal, Vol. 15, No. 3, pp. 282 – 311.

Disu, A. and Gray R. H, (1998). an exploration of social reporting and MNCs in

Nigeria. Social and Environmental Accounting18 (2): 13-15.

Gibson, R. & J. Guthrie, J., (1995). “Recent Environmental Disclosures in Annual

Reports of Australian public and private sector Organizations. Accounting

Forum 19(2/3): 111-41.

Gray, R. Owen, D. Adams, C. 1996. Accounting and Accountability – Changes and

Challenges in Corporate Social and Environmental Reporting. Prentice-Hall:

London.

Gray, R.H.; Kouhy, R. and Lavers, S. (1995) “Corporate Social and Environment

reporting: a review of the literature and a longitudinal study of UK

Disclosure” Accounting, Auditing, and Accountability Journal, Vol. 8, No.2,

pp. 47-77

Gray, R. H and Bebbington, J. (2000) “Environmental accounting, managerialism and

sustainability: Is the planet safe in the hands of business and accounting?”

Advances in Environmental Accounting and Management, Vol. 1 No. 1 p. 1-44

Gray, R. H.; Owen, D. L.; and Maunders, K. T; (1991) “Accountability, Corporate

Social Reporting and the External Social Audits” Advances in Public Interest

Accounting Vol.4 pp1-21

Gray, R., D.L.Owen & Adams (1996). Accounting and Accountability. Europe,

Prentice Hall.

Guthrie, J. & Parker, L.D; (1990) “Corporate Social Disclosure Practice : a

- Comparative International Analysis" *Advances in Public Interest Accounting*,
Vol. 3, pp. 159-175
- Hamschmidt, J. and Dyllick, T. (2001). ISO 14001 Profitable? Yes! But is it Eco-effective? *Greener Management International*, 34 summers, 43-54.
- Jasch, C. 2001. *Environmental Management Accounting – Principles and Procedures*.
UNSD, New York.
- Jasch, C. and Schintzer, H. 2002. *Environmental Management Accounting: How to Profit from Environmental Protection*. Vienna: Austrian Ministry of
Technology and Innovation.
- Jasch, C. 2003. The Use of Environmental Management Accounting (EMA) for
Identifying Environmental Costs. *Journal of Cleaner Production*, Vol. 11, 667.
- Jasch, C. 2006. How to Perform an Environmental Cost Assessment in one day.
Journal of Cleaner Production, Vol. 14, 1194-1213.
- Jasch, C. and Lavicka, A. 2006. Pilot Project on Sustainability Management
Accounting with Styrian Automobile cluster. *Journal of Cleaner Production*,
Vol. 14, 1214-1217.
- Kisenyi, V. Gray, R. H. (1998). Social disclosure in Uganda. *Social and Environmental Accounting* 18(2): 16-18.
- Llena, F., Moneva, J. M., & Hernandez, B. (2007). Environmental disclosures and
compulsory accounting standards: The case of spanish annual reports.
Business Strategy and the Environment, 16, 50–63.
doi:10.1002/bse.466
- Moneva, J. M., & Ortas, E. (2010). Corporate environmental and financial performance: a multivariate approach. *Industrial Management & Data
Systems*, 110(2), 193-210. doi:10.1108/02635571011020304
- Scavone, G. 2006. Challenges In Internal Environmental Management Reporting in
Argentina, *Journal of Cleaner Production*, Vol. 14 pp1276-1285.
- Tsang, E. W. K. 1998. A longitudinal study of corporate social reporting in
Singapore: the case of the banking, food and beverages and hotel industries.

Accounting Auditing and accountability Journal 11(3): 624-635.

Turner, J. (1988) A theory of social interaction, Polity Press, Cambridge

US EPA (1995). An Introduction to Environmental Accounting as a Business Management Tools, Key Concepts and Terms. USA: EPA.

Welford, R. (1996). Business and Environmental Policies. In Blowers, A. and Glasbergen, P. (Eds) Environmental Policy in an International Context: Prospects for Environmental Change pp.51-77, London, Arnold of Hodder Headline Group.

Welford, R. 1998. Environmental Issues and Corporate Environmental Management 12 in Welford R. (eds), Corporate Environmental Management 1: System and Strategies. Earth Scans Publication Ltd, London.

IMPLICATIONS OF CARVE-OUTS IN ADOPTING IFRS AS GLOBAL ACCOUNTING STANDARDS – Aghimien, P., MacDonell, D., Jia, X. & Fu, Y.

Abstract

This paper explores the positive and negative implications of carve-outs in the worldwide adoption of International Financial Reporting Standards (IFRS). The European Union (EU) adopted its own version of IFRS for listed companies in 2005, which was instrumental to the promotion of IFRS as a set of universal accounting standards. It wanted to improve the comparability and quality of European financial statements, increase market efficiency, and reduce the cost of capital. However, it did not include certain provisions of IFRS regarding hedge accounting and the use of fair value for financial assets and liabilities. The fair value carve-out has been resolved, but the weakened hedge accounting rules continue to reduce comparability of financial statements and increase compliance costs for banks. In order to provide high-quality financial reports and improve the Brazilian accounting environment, the Brazilian government required all domestic businesses to prepare their financial reports using IFRS from 2010. However, Brazil carved out IFRS based on its particular situation. Brazil eliminated revaluation of assets and forbade full adoption of that provision. Because of Brazil's inflation and its effect on the domestic accounting system, revaluation would provide space for managers to manipulate the books and weaken investors' benefits. For some countries like Brazil, financial reports might be more comparable and reliable as a result of carve-outs. Based on China's special economic system, China has its own accounting standards that differ from IFRS. In discussion of China's part, two different accounting principles published under IFRS and China's accounting standards were used to analyze the implications in these areas: operating results, financial situation, financial ratios, credit rating, and dividend policy. And due to the law, culture, and economic differences between accounting principles in the source of the accounting environment and China's short history of economic progress, Chinese accounting standards will be still different from IFRS for a long time.

KEYWORDS: Carve-outs; IFRS; EU; Brazil; China.

1 Introduction

As globalization has become the driving economic force of our times, convergence of global accounting standards has become a crucial aspect of a functioning, effective, global marketplace. Limited by the size of the domestic markets, businesses have invested in foreign expansion at an almost exponential rate over the last fifty years. However, diverse accounting standards from all over the world have presented a number of obstacles to multi-national businesses. There are high costs associated with translating the local financial reporting to the applicable accounting standards, and from local currency to domestic currency. What is more, for a multinational business, diversity of the accounting standards weakens the comparability of its segments' financial reports. Consequently, management may not be able to make correct decisions based on differing financial statements. In order to finance the expansion strategy, cross-listing in foreign stock markets may also require the businesses to adjust their consolidated financial reports from domestic accounting standards into local Generally Accepted Accounting Principles (GAAP). Considerable efforts and costs involved in this process could frustrate businesses. Moreover, from the standpoint of international investors, low comparability among the global accounting standards tends to lower their confidence in these capital markets. At the same time, different countries on the same stock exchange could operate under different overall accounting frameworks. For example, considering the issue of disclosure, code law countries such as Germany have a low level of transparency compared with the common law countries like the United States. Lack of high-quality accounting information hinders the development of the international investment market because investors are likely to become more wary and less prone to lend.

In order to solve this problem, the International Accounting Standards Board (IASB) took over the establishment of International Financial Reporting Standards (IFRS) from the International Accounting Standards Committee (IASC) in 2001. After that, there are more than 100 countries that either require or allow IFRS, and an increasing number of countries are attempting to convergence their local GAAP to IFRS. According to Paul Pacter (2014), "In the 12 years since the reform of the IASC, the IA has produced many new standards under IFRS and has overhauled the standards it inherited from the IASC. More than 100 jurisdictions have now adopted IFRS" (p. 6). The goal of convergence to one global high-quality set of accounting standards is lofty, but achievable. "IFRS offer[s] great opportunities to improve the transparency and comparability of financial statements globally, with positive effects on the development and integration of capital markets, and global economic growth and

development in general" (Obradovic, 2014, p. 2). Among the countries that have adopted IFRS, there are network benefits. According to prior research, Ramanna and Sletten (2014) pointed out that "network benefits are likely to arise from lower perceived transaction costs of foreign investment and trade" (p. 1524). Unifying accounting standards helps to reduce extra costs of translating financial reports of multinational businesses for operations and investment. Greater comparability across country lines allows investors and other users of financial statements to make accurate and timely comparisons of companies' performance and financial standing. Once started, convergence to IFRS has been pushed forward by its own momentum: as more countries adopt, more and more other countries will want to adopt in order to increase comparability with a wider range of companies. For example, since the European Union (EU) has accepted IFRS, other countries have had to adopt IFRS if they want to build a better economic connection with EU.

However, like Pacter (2014) said, "Adoption of IFRS is not black or white (yes or no) – it is shades of gray" (p. 6). Because of different cultures and complicated political reasons, fully adopting IFRS is quite difficult. On one hand, the governments need to set a considerable amount of budget for rebuilding the accounting education system, restructuring the auditing system, adjusting regulations and laws, and helping businesses, especially listed companies, become familiar with IFRS. On the other hand, it is true that not all national accounting standards are suitable for changing to IFRS. Full adoption could cause negative impacts for the national economy. In many of these cases, a country will adopt only part of IFRS as established by the IASB.

At this point, carve-outs would be a wise choice as opposed to full convergence. Carve-outs in adopting IFRS means a country adopts most aspects of the IFRS except those conflicting with its benefits. These parts are "carved out" of the country's version of IFRS and not applied by the standard-setting body. The IFRS provisions in question could also be modified in some way, rather than removed completely. This creates a situation in which certain countries have adopted IFRS in name, but have created different versions of the standards to suit their own individual needs. It is harmonization rather than convergence. But, it is a step toward adoption; it's better to have a modified version of IFRS that could be rectified in the future than no IFRS at all. The EU's adoption of IFRS is representative of carve-outs because it had professional committee revalue and adjust the IFRS standards to its particular situation. In other words, on the way to carve-outs, jurisdictions seek common points while reserving differences.

Carve-outs also have their own negative effect. One of the main obstacles to creating a truly global set of accounting standards is the fact that the IASB does not have any regulatory power over countries adopting

IFRS: it sets the provisions and hopes standard-setters will adopt and apply them. Because of its inability to enforce the rules it creates, the IASB cannot guarantee the consistent application of IFRS across nations, which undermines the stated goal of convergence. That being said, the IASB does not allow countries with carve-outs to claim that they have fully adopted IFRS. Instead they must disclose their alteration with a name such as "IFRS as adopted by the European Union," which signals to investors and creditors that some aspect of IFRS has been modified. Carve-outs may weaken the effects of adopting IFRS as the international set of accounting standards because carve-outs would allow the countries to set different adjusted IFRS at the same time. "If you start to have carve-outs and national tweaks, then the IASB would have not achieved its objective and comparability would be lost" (IFRS Outlook, 2012, p. 7). It is possible that because of carve-outs, the core of the problems caused by diversity would still exist, despite global adoption of IFRS.

The next sections in this paper discuss how the EU, Brazil, and China interact with IFRS, and the implications of carve-outs in adopting IFRS in those three countries or regions.

2.1 Introduction - EU

In 2002, the EU published a regulation called "Regulation (EC) No. 1606/2002 of the European Parliament and of the Council of 19 July 2002 on the application of international accounting standards." This act required the application of IFRS for all consolidated accounts of publicly traded EU companies by January 1, 2005 (IAS Regulation, 2015). The accounting requirements for individual accounts of publicly traded companies, consolidated accounts of non-listed companies, and individual accounts of non-listed companies were left to the member countries' discretion. EU countries could opt to require, allow, or not allow IFRS for these entities. Despite the great variety this caused for requirements of non-publicly traded companies, EU listed companies were finally using one, standardized set of accounting rules, rather than each country's local GAAP.

2.2 Benefits of EU-IFRS convergence

In order to understand the impact of the EU carve-outs, one must understand the objectives and advantages of the EU's adoption of IFRS. The goal was to create one singular European capital market. Doing so has benefits both within the EU itself and between the EU member states and outside countries. First, having one set of standards breaks down barriers to cross-border trading, which simultaneously increases market efficiency, and a firm's ability to raise capital from a variety of different external sources. This is due to "improved transparency, comparability and quality of financial reporting that lead to lower preparation costs, more efficient investment decisions, and lower cost of capital for companies" (Jermakowicz & Gornik-Tomaszewski, 2006, p. 172).

Second, IFRS is considered more “investor-oriented” than many of the code law countries’ local GAAP. Moving from creditor-oriented to investor-oriented accounting standards should attract more investors to finance EU companies with higher quality accounting information (Guggiola, 2010, p. 2). High quality accounting information is dependent on factors such as understandability, comparability, relevance, and timeliness. “Similar to managers, investors can use information reported by peer firms to mitigate their uncertainties about market conditions and distinguish better investment projects from poorer ones” (Chen, Young, Zhuang, 2013, p. 883). If investors have more trust in the financial statements of EU listed companies, they will generally provide more capital and charge less for it. On the other hand, if investors feel as if there is a lack of relevance, timeliness, or reliability associated with the financial statements of publicly traded companies, they will typically withhold capital or charge a premium for the additional perceived risk. At the same time, European companies may choose to seek out capital within the improved EU markets, rather than the U.S. markets. Along these same lines, convergence also reduces investor uncertainty, simplifies international auditing, facilitates increased mergers and acquisitions activity, and improves “market liquidity, corporate investment efficiency, and international capital flows” (IFRS in the EU, 2014, p. 2).

Finally, the adoption of IFRS by the EU was a catalyst in creating a greater push toward having one set of global accounting standards. It represented a turning point in the history of global IFRS adoption. As a result of having such a large and influential economic bloc like the EU formally endorse IFRS, many other companies and countries rushed to switch over. This trend continues today as other large countries like India and China converge local GAAP with IFRS. The EU’s adoption lent IFRS and the IASB credibility and global recognition as a viable, rigorous set of accounting standards.

2.3 IFRS as adopted by the EU

It’s important to understand what the benefits of harmonization and convergence of accounting standards are because carve-outs actually undermine all the advantages enumerated above. The EU did not adopt IFRS as published by the IASB. Instead, the European Parliament passed its own version of IFRS, with certain provisions regarding the fair-value method of measuring financial instruments and hedge accounting removed or modified. It was able to do so because the EU has an endorsement process for adopting individual IFRS standards. This process requires formal advisement from the European Financial Reporting Advisory Group (EFRAG), an affirmative vote from Accounting Regulatory Committee (ARC), positive opinions from the European Parliament and the Council of the European Union, and publication in the *Official Journal of the European Union* (Pacter, 2014, p. 9). In essence, “each standard

must earn a two- tiered endorsement involving a possible ‘carve-out option’, under which the application of the standard can be delayed or avoided” (Verriest, Gaeremynck, & Thornton, 2013). The provisions in question were from International Accounting Standard (IAS) 39, *Financial Instruments: Recognition and Measurement* and IAS 32, *Financial Instruments: Disclosure and Presentation*. First, IFRS as adopted by the EU loosened some of the requirements for fair value hedging of portfolio interest rate risk. Second, the EU removed language from IAS 32 that allowed the fair value option for some financial liabilities.

2.4 Hedge Accounting under IAS 39

Management uses hedges to mitigate risk from exposure to changes in foreign exchange rates, interest rates, etc. It can hedge assets, liabilities, groups of assets and liabilities, held-to-maturity investments, cash flows, and portfolios. Essentially, hedge accounting allows banks or companies to match gains and losses of a hedging instrument with offsetting gains and losses of the actual hedged item. If these gains and losses aren’t accounted for in the same period, it creates a mismatch between the hedged asset or liability, and the corresponding hedging instrument. In order to apply hedge accounting, hedges must meet criteria such as formal designation and effectiveness tests. IAS 39 allows hedge accounting in following three ways: fair value hedges under certain circumstances, cash flow hedges, and hedges of net investments in foreign operations. Below are two figures from a PricewaterhouseCoopers’ (PwC) “IAS 39 Hedging” guidance document (2005, p. 4-5) which the continual process of hedging, the three different hedging characterizations, and the corresponding types of trading instruments:

Figure 1: The Hedging Process

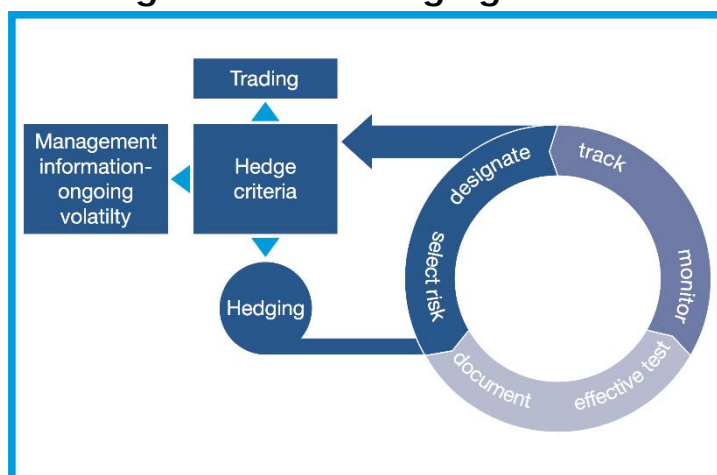
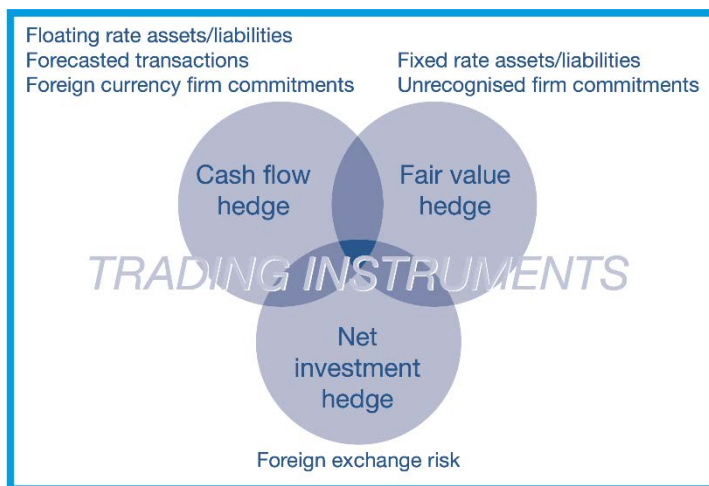

Figure 2: Hedging Characterizations and Trading Instruments



IAS 39 does not allow fair value valuations for hedges associated with interest rate risk for portfolios of on-demand or core deposits. The version of IFRS adopted by the EU carved-out this section of IAS 39, and allowed fair value hedging under these circumstances.

2.5 Implications of the hedge accounting carve-out

There are a number of implications that arose from the adoption of this modified version of IFRS. First, allowing fair value actually softens the provisions for hedge accounting, making IAS 39 less rigorous. Indeed, "the adopted standard includes seriously weakened hedge accounting requirements and may give rise to artificial volatility in reported profits" (Doupnik & Perera, 2015, p. 97). The volatility occurs because the hedged item is accounted for by amortized cost, while the hedging instrument is measured at fair value. Second, because companies can choose between cash-flow and fair value hedging treatments, the risk increases of companies applying two different accounting methods to substantially the same situation of underlying economics. The whole point of convergence is to create one set of standards which companies follow when certain economic events occur within a business. The allowance of alternative accounting treatments is more akin to harmonization, which maintains a high level of flexibility of choice, but decreases comparability. This works against the objective of globally adopting IFRS. "The flexibility provided in this carve-out will impair comparability across EU companies, and with non-EU companies that apply IAS 39 as issued" (Brackney, 2005). Third, applying only partial sets of IFRS could reduce the reliability of European capital markets. Because companies have to disclose the fact they are using "IFRS as adopted by the EU," investors may be uncertain about what has been modified or removed. Evidence has shown that "financial firm investors view net income measured in accordance with IAS 39, including its greater use of fair value measurement, recognition of derivatives, and its specified requirements for hedge accounting, as more value relevant than net income measured in accordance with domestic standards" (Barth, Landsman, Young, & Zhuang, 2014). Fourth, some companies' cost of compliance increased. This is because the SEC requires

accordance with full IFRS in order to file accounts with it. For companies who apply IFRS as adopted by the EU, they must use that version to file with the European markets, and then reverse it out to apply full IFRS when filing with the SEC (IFRS 9 Financial Instruments: Status Update, 2011, p. 8). Finally, carve-outs like these delay the full implementation of IFRS as an international set of accounting standards. This is extremely important since “consistency in the interpretation, application, and regulation of IFRS is crucial to achieving a single set of high-quality global standards. Otherwise, the standards are ‘global’ in name only” (IFRS Outlook, 2012, p. 7). It sets an undesirable precedent for other countries to follow suit and adopt their own nationalized versions of IFRS.

2.6 Fair value option carve-out

The EU also carved out a section of IAS 39 pertaining to the application of fair value measurement of assets or liabilities, some of which were covered under IAS 32 *Financial Instruments: Disclosure and Presentation*. The IASB initially allowed the fair-value option for financial assets and liabilities. The European Central Bank (ECB) opposed this view since it believed deteriorating banks would use the option to write down liabilities due to their own worsening credit conditions (Brackney, 2005). Due to pressure from the ECB, IFRS as adopted by the EU removed the fair-value option as of November 2004. However, this carve-out was resolved relatively quickly. As a compromise with EU banks and insurers, the ECB petitioned the IASB to only allow fair value measurement for assets and liabilities with financial aspects in a limited set of circumstances. These circumstances include: those assets or liabilities with embedded derivatives, those where using the fair-value option reduces mismatches in accounting, and those for which fair value is part of an established risk management practice (Deloitte, 2005). The IASB agreed with these provisions, and published an amendment to IAS 39 that the EU endorsed during July 2005. Some have suggested that this is a great example of how carve-outs should be resolved: standard-setters and the IASB should work together to compromise on provisions that are seen as problematic. Hopefully, a middle ground can be achieved so that the IASB isn’t changing the standards for every country, but is also working with policy makers to improve upon current provisions.

2.7 IFRS 9: An Improvement?

In November 2013, the IASB introduced IFRS 9 Financial Instruments, which was intended as a replacement of IAS 39. IFRS 9 is more principles-based than IAS 39 and makes significant changes in a number of areas. These changes include: simplified prospective effectiveness testing, allowing more items for which hedge accounting applies, and less volatility on the income statement when using options, foreign currency swaps, and forwards (IFRS 9 Financial Instruments – Classification and Measurement, 2014). However, IFRS 9 does not

address the hedge accounting carve-out. “Entities that apply IFRS 9 for hedge accounting will still have the scope exception available that allows IAS 39 to be applied instead of IFRS 9 . . . that means the carve-out will be available to them in the same way as it is currently” (IFRS Outlook, 2012, p. 3). IFRS 9 simplifies and improves hedge accounting, and the reaction of the EU market to its publication has generally been positive (Onali & Ginesti, 2014). However, it does not solve the problem resulting from the carved-out adoption of IAS 39.

2.8 Conclusion - EU

There are two carve-outs related to the EU’s version of IFRS: one regarding hedge accounting and one about the use of the fair value option. While the fair value option issue has been resolved, the carve out regarding hedge accounting is still outstanding. It continues to impair comparability and increases compliance costs for certain banks. This situation of carve-outs in adopting IFRS is not specific to the EU: many countries have formally “adopted” IFRS while allowing aspects of their old accounting system to remain. Again, the IASB needs to communicate closely with governmental agencies and other formal authorities so that carve-outs are limited.

3.1 Introduction - Brazil

The importance of nearly all Latin America to the global economy is a growing issue recently, especially in light of the recovery from the late 2008 world economic instability. In order to attract more foreign capital and develop international investment in Latin America, applying a set of high-quality, effective accounting standards to improve the quality and environment of financial reports has become a significant priority. After its establishment by the IASB, many Latin American countries have adopted IFRS. However, considering their specific conditions, some countries have chosen to modify the IFRS in order to fit their particular economic environment.

3.2 How Brazil adopted IFRS

Brazil plays an important and influential role in Latin America’s economy. Brazil announced the change from its own accounting standards to IFRS in 2007. In 2008, a committee established specifically for this purpose issued a number of accounting standards based on IFRS; however, Brazil did not fully adopt IFRS until 2010.

Based on Brazil’s particular culture, business climate, and economic environment, Brazil used carve-outs with IFRS for certain regulations. In the introduction to this paper, carve-outs were defined as the following: a country adopts most aspects of the IFRS except those conflicting with its benefits. As the IFRS Foundation (2015) mentioned in its reports, Brazil eliminated revaluation of fixed assets and intangible assets, which are under IAS 16 and IAS 38 (p. 6). Brazil values fixed assets at historical cost plus the inflation adjustment index. The CPC, which is the Brazilian

Accounting Pronouncements Committee, and the CVM, which is the Securities and Exchange Commission of Brazil, also require that businesses must record their investment in subsidiaries by using the equity method in the parent companies' financial statements. In addition, as Biancone (2013) mentioned in his research, Brazilian businesses are required to present additional information not required by IFRS, such as the presentation of the statement of value added (p. 9).

3.3 Why Brazil removed revaluation of fixed assets

There are several explanations for this issue. The first explanation is the lack of investors. Because of historical reasons, the Latin American accounting systems are influenced deeply by the European accounting systems. From this point of view, the Brazilian accounting system is generally principles-based. Brazilian businesses pay more attention to information for insider ownership and less to disclosures for external investors.

Second, the way in which Brazilian companies apply revaluation is unsatisfactory to users of their financial statements, because "IFRS requires a greater use of fair value accounting ... [which] will likely result in increased volatility of the company's profit or loss" (IFRS and CPCs, 2010, p. 13). According to Lopes and Walker (2012), "revaluations of fixed assets in Brazil are not designed to convey information to external users of financial statements, but rather to improve reported equity positions to avoid covenant violations" (p. 54). In the past, Brazilian businesses used revaluation to increase the fixed assets' book value in order to polish the balance sheets, instead of providing high quality accounting reports. This allows companies to "cook the book" during a poor financial year, in order to keep their healthy financial status. Implementation of the revaluation in such an environment would make the reliability and comparability of the Brazilian financial reports even worse.

3.4 Implication of carve-outs in Brazil

Elimination of the revaluation allows the Brazilian businesses to avoid the potential expense. Fair value measurement in Brazil is more complicated and expensive than in European countries because of the unsatisfied quality of information and increasing inflation. In other words, determination of the fair value would make Brazilian businesses pay considerable costs and efforts to research and analyze. As a result, the companies' expenses would increase while the profits decrease. This is especially so for small/medium sized enterprises as revaluation could increase the weight of their financial burden.

Modified IFRS helps Brazil improve the quality of accounting information and capital market environment. According to Macedo, Machado, and Mendonca (2013), using a modified IFRS the profits and

other financial ratios are more reliable to represent the economic reality of the Brazilian businesses. What is more, Santana et al (2014) pointed out in their paper "Economic Effects of IFRS Adoption in Brazil," that the stock price synchronicity in Brazil has been reduced since Brazil mandatory adoption of IFRS. This evidence shows that the level of transparency of the Brazilian accounting information has improved as well as the investment environment. Because, in this situation, the stock prices are more capable of representing the fundamental situation and financial information of the businesses. Additionally, the external investors have more accesses to obtain the financial information. What is more, this also indicates that the Brazilian capital market is becoming reliable. The increasing reliable financial information make Brazil more attractive to the international investors. Revaluation could cause negative effects on the businesses' future performance. Revaluation of fixed assets let the managers polish the companies' real financial situations, and weaken the external investors' benefits. It has been suggested that by using a modified IFRS "firms with superior growth options are more likely to adopt more rigorous corporate governance arrangements in order to attract external sources of funds to finance growth opportunities" (Lopes & Walker, 2012, p. 62).

From the manager's perspective, when the company suffers from a poor financial situation, the managers may use the revaluation of fixed assets to artificially improve the balance sheet and obtain extra capital from external investors. However depreciation would increase as well. Generally, the amount of the depreciation is usually larger when an asset is revalued upward. Consequently, dividends and taxes for the year could be reduced by the decline of net income. In the long term decline of dividends and net income would make investors withdraw their capital.

From the external investors, they may be assuming more risk. Because of inflation in Latin America, the assets' market value are higher than their real fair value, which means the fixed assets are overvalued. On the other hand, the size of the indebtedness would be undervalued. By the basic accounting equation, the company has to set up a revaluation reserve to the shareholders to increase the equity if it wants to upward revalue the assets' value. Thus, the debt-to-equity ratio, which is one the significant measurements for analyzing a company, would be superficially lowered. The higher the assets' value, the higher the revaluation reserve, the lower the debt-to-equity ratio, holding the amount of the debt constant. "Firms with more leverage are likely to benefit most from revaluations because revaluations increase the book value of equity and reduce the chances of covenant violations" (Lopes & Walker, 2012, p. 63). In this situation, the banks and investors may not be able to analyze the debt paying ability of the company. In addition, the share price would be lower as result of the dividends reduction. For the shareholders, even

though the company has revaluation reserve, the lower share price may still make them lose money. If the cash chain breaks, not only could the company go bankrupt, but the banks and investors could also suffer huge losses. Consequently, the economy of Brazil would weaken, with negative effects on the worldwide economy. The external investors would lose confidence in the Brazilian capital market. Rebuilding reliability and trust is far more difficult than destroying it.

What is more, mandatory application of the revaluation of fixed assets would conflict with some public companies' benefits. Because IFRS has not been fully adopted everywhere yet, several international capital markets, such as the United States and China, do not allow revaluations. Taking the United States as an example, US GAAP is generally stricter than IFRS, because US GAAP is rules-based while IFRS is principles-based. So, even though the US SEC has allowed foreign public businesses to prepare their consolidated financial statements by using IFRS, many of them still choose to prepare under US GAAP. That may be because the U.S. investors still prefer the U.S. edition of financial reports. Although there have been several convergence programs by FASB and IASB, revaluation is still not allowed under US GAAP. Additionally, to file financial statements with the US SEC, full IFRS compliance is required. As for China, perhaps a Brazilian company may want to cross-list on the Chinese stock exchange. However, revaluation is not permitted under China's IFRS adoption. In these situations, Brazilian firms will have higher costs of compliance since they must prepare financial statements both with and without the revaluation, if the Brazil government implements revaluation.

3.5 Conclusion - Brazil

The purpose of Brazil's adoption of IFRS is to provide high quality financial reports and improve the Brazilian accounting information environment. However, considering the specific conditions of Brazil, revaluations of fixed assets have to be removed from the original IFRS published by IASB, because revaluation in Brazil may not be able to provide valuable information. The result is a carve-out.

If Brazil completely adopted IFRS, the Brazilian economy would be negatively impacted. First, the inflation will make market values much higher than the real values. Determining the fair value will be difficult. Second, managers may use revaluation to modify the financial statements. The reliability of the accounting information would be weakened. Third, public enterprises, especially the cross-listed enterprise, would incur additional costs to adjust the consolidated financial statements, to be acceptable in foreign stock exchanges. Double adjustment is not worth it. According to Lemes, Santos, and Rodrigues (2013), revaluation does affect Brazilian businesses when compared with other factors (p. 599). This indirectly proves that revaluation makes Brazilian financial statements less comparable and results in less accuracy

in

Santana, et al (2014) assert that “cultural and domestic characteristics are believed to influence accounting practices and a global accounting standard might not be able to eliminate this influence” (p. 6). In this case, the countries, especially developing countries, need to consider whether they need to restrict or limit the particular items from the IFRS published by IASB.

4.1 Introduction - China

In February 2003, six major accounting firms announced a joint report entitled “GAAP Convergence 2002.” The report showed that of the 59 jurisdictions interviewed, including China, more than 90% expressed their willingness to integrate with IFRS. 72% of these countries already had the economic and political conditions necessary for integrating listed companies with IFRS. 22% of them indicated that they are willing to adopt IFRS step by step, and 20% said they would eliminate differences between local accounting standards and IFRS. These statistics show the growing trend of countries eager to adopt IFRS and change their local GAAP in the process.

With regards to China, the development of Chinese accounting standards has gone through four phases. The first phase, from 1978 to 1992, was the exploratory phase of accounting standards. The second phase, from 1992 to 1998, was the gradual establishment of accounting standards. The third phase, from 1999 to 2005, was the comprehensive development stage for China’s accounting standards. Finally, the fourth phase has been since 2006: local accounting standards convergence with IFRS. From the third phase, with China’s opening to the global economic market, China’s economic development path changed from socialist to socialist market economy. This economic structure combines socialism with the capitalist economy. In November 1992, the publication of Accounting Standards for Business Enterprises (ASBE) meant China applied their homegrown accounting standards to all domestic companies, both small and large. Several years later, they developed accounting standards allocated to specific industries. During the third phase of their accounting development, China joined the World Trade Organization (WTO). This necessitated their push to convergence with IFRS. Since 2006, the Chinese Treasury has published 20 more specific accounting standards.

In China’s quest to become involved in the global economic market, the issue of “Qiongminyuan” (a listed company fraud on their capital reserves with related-parties to make their stock price higher) forced the publication of “Disclosure of Relationship and Transactions with Related-parties.” More specific items were added into previous accounting standards, and the standards became more rules-based. This happened because accounting standards often reflect the economic environment. On

the one hand, global economic forces make convergence of Chinese accounting standards with IFRS preferable. On the other hand, the Chinese economic system that combines socialism with a capitalist economy makes it quite difficult to converge with IFRS. Consequently, it is inevitable that carve-outs will result from this type of situation. China partially accepted IFRS as an overall guide, but still has its own special accounting standards to implement in Chinese society. It has been suggested that by creating carve-outs, China has been able to improve its economy. For instance, during 1999 and 2000, many public companies used the rule “the gain from restructure allocates to profits” for false restructuring. China modified these rules in 2001. The process of carve-outs can be seen as a procedure to continually improve them.

In the remaining part of this section, this paper focuses on the implications of carve-outs in China. Firstly, what are the differences between Chinese accounting standards and IFRS? Secondly, what are some of the influences of carve-outs in adopting IFRS in China? Thirdly, why did China partially accept IFRS instead of all of it? Fourthly, what is the future for China’s accounting standards?

Specifically, what are the implications of China’s carve-outs in adopting IFRS in areas such as, operating results, financial ratios, credit rating, and dividend policy?

4.2 The implications of operating results differences between Chinese accounting standards and IFRS

4.2.1 Investment Property

IAS 40, *Investment Property* applies to rental properties or property held for capital appreciation. “Investment properties are initially measured at cost and, with some exceptions, may be subsequently measured using a cost model or fair value model, with changes in the fair value under the fair value model being recognized in profit or loss” (IAS 40, December 2013). IAS 40 allows entities to choose between two methods: a fair value model and a cost model. Investment property such as buildings or land could be used for either rentals or appreciations. In the case of operating leases, they “may be classified as investment property if the rest of the definition of investment property is met and the lessee measures all of its investment property at fair value” (IAS 40, December 2013).

In practice, the fair value method is more popular under IFRS. However, in China, the cost method is often chosen for investment property, because the scope of the fair value method is narrower and more detailed. Due to the Chinese housing price boom in recent years, the increased amount in fair market value of investment property has been accounted for in investment income. Under IFRS, investment income and net income are higher than in Chinese accounting standards. Furthermore, depreciation and amortization are not included in the fair

value method. Operating costs are then lower as a result, which contributes to higher margins. So, under IFRS, profits are higher. Figure 1 (below) summarizes the profits under Chinese accounting standards when compared to IFRS separately:

Figure 1

Investment property differences between IFRS and Chinese accounting standards

	IFRS	Chinese accounting standards
Popular method	Fair value method	Cost method
Market environment	More active economic environment	(1) Market value method is more detailed, and the scope is smaller. (2) Government does not encourage fair value method.
Profits	Higher	Lower
Reasons	(1) No depreciation in market value method. (2) Amount due to increase in fair market value accounted into "investment income."	(1) More depreciation. (2) More operating costs.
Implications	One reason why finance crisis happened.	Market is more stable.

Under Chinese accounting standards, the housing market tends to be more stable. Firstly, as discussed above, China usually uses cost method to record the value of investment property. The value of investment property would remain steady year over year on the books. On the contrary, the value of investment property under IFRS would change constantly due to market fluctuations. Secondly, since the Chinese government ultimately takes ownership of the land after its use, real estate businessmen can only secure the properties for 50 or 70 years (50 years for business purposes, 70 years for residential purposes). Due to the Asian financial crisis that occurred in Japanese real estate first, this regulation and control of the real estate market from Chinese governments is necessary. From this perspective, the market in China is more stable and fewer financial crises have occurred as a result.

4.2.2. Reversal of impairment of assets

IFRS allows recovery of the impairment of assets, which Chinese accounting standards reject. In IAS 36.119, reversal of an impairment loss is recognized in the profit or loss unless it relates to a revalued asset (IAS 36, 2004). Impairment of goodwill cannot be reversed. In the year of reversal, the reversal amount should be accounted for in profits under

IFRS. In the IFRS scenario, profits would be higher than with Chinese accounting standards. In the year of disposal, Chinese accounting standards require one-time dealing with impairment of assets. This gives companies the chance to reap higher profits from assets disposal in the disposal year. Under IFRS, impaired assets can be reversed in the years that impairment factors are eliminated. The following factors can influence impairment of assets: market value declines; negative changes in technology, markets, economy, or laws; increases in market interest rates; and net assets of the company are higher than market capitalization (IAS 36, 2004). Figure 2 summarizes the differences between IFRS and Chinese accounting standards for impairment reversals:

Figure 2

Reversal of impairment differences between IFRS and Chinese accounting standards

	IFRS	Chinese accounting standards
Attitude towards reversal of impairments	Allowed	Not Allowed
In reversal year	Accounted into profits	---
In disposal year	A factor causing impairment can be reversed.	(1) One-time reversal of impairments. (2) Accounted into profits or loss.

Although analysts believe that Chinese accounting standards prohibit income manipulation, they are unable to fully explain the reasons for higher profits resulting from disposal of long-term assets.

4.3 The implications of differences between Chinese accounting standards and IFRS

Differences between IFRS and Chinese accounting standards can affect both the income statement and the balance sheet. Since fixed assets can be revalued under IFRS, the recoverable amount of long-term assets could be more than the carrying value. The difference between the recoverable amount and carrying value is included in profits, which can lead to an increase in retained earnings. Because reversal of impairments of fixed assets is not allowed under Chinese accounting principles, the impairment account is typically higher under these conditions. In conclusion, non-current assets, total assets, and retained earnings should be higher under IFRS than under Chinese accounting standards. Figure 3 illustrates these differences between IFRS and Chinese accounting standards through a fictitious balance sheet, assuming all conditions are the same except for the impairment of fixed assets:

Figure 3

Balance sheet of Company X

December

31st

20XX

unit: thousands

Accounts	IFRS	Chinese accounting standards
Cash and cash equivalents	100	100
Inventory	<u>50</u>	<u>50</u>
Total Current Assets	150	150
Fixed Assets	300	300
Impairment of Fixed Assets	50	100
Net Value of Fixed Assets	250	200
Work-in process	<u>50</u>	<u>50</u>
Total non-current assets	300	250
Total Assets	<u>450</u>	<u>400</u>
Notes Payable	90	90
Accounts Payable	100	100
Long-term Debt	<u>90</u>	<u>90</u>
Total Liabilities	280	280
Common Stock	100	100
Retained Earnings	70	20
Total Equity	<u>170</u>	<u>120</u>
Total Liabilities and Equity	<u>450</u>	<u>400</u>

4.4 The implications of financial ratio differences between Chinese accounting standards and IFRS

4.4.1 Debt ratio

Debt ratio = total debt / total assets

Prohibition of the reversal of impairment means the net value of fixed assets is lower under Chinese accounting standards. The total debt amount is the same regardless of which accounting standards are used. Therefore, the company's debt ratio is higher under Chinese accounting standards than under IFRS. From Figure 3, Company X's debt ratio is 70% (280 / 400) when computed using Chinese accounting standards, while it is only 62.22% (280 / 450) under IFRS.

4.4.2 Total assets turnover ratio

Total assets turnover ratio = Sales / total assets

Similarly, we can see from Figure 3 that under Chinese accounting standards, the total assets balance (400) is lower than the balance under IFRS (450). Based on the same sales revenue, assets turnover ratio calculated under Chinese accounting standards is higher than under IFRS.

4.4.3 Implications of different financial ratios

Generally, these financial ratios are a reflection of the company's overall performance. The differences between IFRS and Chinese accounting standards can influence the company's profitability measures, debt paying ability, and evaluation of management performance. Therefore, these differences are significant for investors, creditors, managers, and other financial statement users.

4.5 Credit rating and dividend policy's differences between Chinese accounting standards and IFRS

In capital markets, many investment banks use credit ratings to evaluate listed companies. An important aspect of determining a company's credit rating is financial ratio analysis. As previously mentioned, differences between IFRS and Chinese accounting standards can significantly change financial ratios. Therefore, it is highly possible that these differences could negatively influence a company's credit rating. Once investors start to recognize low credit ratings, the stock price of a company could also fall. Furthermore, dividends payouts are connected with a company's performance. Differences between IFRS and Chinese accounting standards also influence a company's net profit, which could affect whether the company pays out dividends or not.

4.6 The accounting environment is the source of differences between accounting principles

Differences between IFRS and Chinese accounting standards exist because they are the result of different accounting environments. The accounting environment is influenced by a number of internal and external factors including economics, accessibility of information, and legal matters.

4.6.1 Economic Factor

The economic factor includes the level of economic development (first-world or third-world), degree of market accessibility (open or closed), operating method (conservative or optimistic), and the maturity of capital markets (undeveloped or mature). Firstly, when it comes to most of these elements, China's unique economy differs from many of the countries that have adopted IFRS. Therefore, it is almost impossible that Chinese accounting standards would develop in the same manner as other IFRS countries. Secondly, China needs patience to attract more foreign direct investment (FDI), continue self-development, and enlarge its domestic economy. Therefore, convergence between Chinese accounting standards and IFRS should be approached with a conservative and patient attitude. As Blake & Gao (2013) note, "If China persists in not recognizing

conservatism as an accounting concept and does not allow some application of conservatism in practice, there is no doubt that assets can be overstated. It may disadvantage international trade and investment" (p. 164). Thirdly, the Chinese capital market is underdeveloped compared with mature Western capital markets. Accordingly, supervision and restraints on speculation are inadequate, and fraud is still committed occasionally. At this point, fair market value does not have reliability and accuracy since "the quality of business reporting is sensitive to the quality of legal enforcement" (Jiang, G., & Penman, S., 2013, p. 53). The prohibition of the reversal of impairments and discouragement of the fair value method are attempts to rein in speculation in the market. If Chinese accounting standards were similar to IFRS, opportunistic practices would more likely occur.

4.6.2 Information Factor

The accuracy and openness of information has also significantly influenced carve-outs in adopting IFRS. The fair value method isn't allowed because China's capital markets are still not credible enough to support it. Information received from the market needs regulation and supervision to improve its accuracy. "After mandatory IFRS adoption, forecast accuracy and other measures of the quality of the information environment increase significantly more for mandatory adopters relative to non-adopters and voluntary adopters" (Horton, J., Serafeim, G., & Serafeim, I., 2013, p. 389). To improve the quality of market information, it is necessary for China to adopt more IFRS principles when it is appropriate to do so. Once its capital markets have developed more, China's information environment can become highly transparent and precise.

4.6.3 Legal Factor

The Chinese government constructs the items of law, and the people have no right to modify them. Since the Chinese government publishes Chinese accounting law, it has the characteristics of coerciveness. As a result, creation of alternative accounting principles or interpretative guidance is not allowed. Disagreement or even discussion is discouraged. Even if domestic companies wanted to follow IFRS standards that have been carved out, they could not. In Western countries, accounting standards are published by non-governmental organizations. This creates a more collaborative environment between the government, standard-setters, and independent accounting bodies.

4.7 Conclusion - China

While it has made progress, the Chinese economy is still underdeveloped compared with other Western countries. Although China can gradually narrow the gap with other developed countries, economic development is a long and arduous process. It is impossible to complete "overnight," especially when Western countries have had a hundred-years

head start. Full convergence of IFRS with Chinese accounting standards is necessary for this development. "In addition, we find that forecast accuracy improves more for firms with accounting treatments that differ the most from IFRS" (Horton, J., Serafeim, G., Serafeim, I., 2013). In other words, the more different a country's domestic standards are from IFRS, the more it has to gain from adoption. "In particular, although none of the Chinese companies had adopted IFRS, they seemed to believe that the integration of IFRS with management accounting could result in some form of expense reduction as well as better global credibility and mergers simplification" (Mert, I., 2014, p. 126). In China's case, compliance with an international set of rigorous accounting standards coupled with sustained economic development should make it a force to be reckoned with.

Furthermore, the capital market in China has not reached Western countries' degree of quality. The socialist market economic system is not perfect; its various elements, including capital markets, are not reputable enough yet. Despite this, China's socialist system of public ownership is less likely to move closer to Western countries' capitalist private ownership system. Thus, the economic differences between countries will inevitably continue to exist.

Finally, while differences between Chinese accounting standards and IFRS have been reduced significantly in recent years, the Chinese government still has no plans for full convergence. This will become problematic in the future, as convergence is still needed for genuine economic development.

5 Summary

Carve-outs in adopting IFRS are a pressing issue in the modern field of accounting. In some respects, carve-outs diminish the efforts of convergence to one set of global accounting standards. In another sense, carve-outs allow countries to take the first step toward full adoption on their own terms. There are a number of solutions available to deal with the problem of carve-outs.

A global database could be created, perhaps by the IASB, to monitor which countries have adopted IFRS, along with information about any modifications or changes they made to the standards. This would provide more transparency to investors and users of financial statements as to the true nature of a particular country's version of IFRS. It would also encourage countries to fully adopt IFRS as published by the IASB because of the centralized, public nature of the database.

Brazil and China are both developing countries and major exporters with huge amounts of contracts with the U.S. and other export-intensive countries. Developing countries' economies are built on small and medium-sized enterprises (SMEs). Input from SMEs in the development of accounting standards is scarce. "Only in 2007 did the IASB recruit more

voices from SMEs and carried out a number of field studies, yet, we believe these efforts have not provided a desirable balance of input into the standard setting process by both academics and developing economies" (Devi, S. S. & Samujh, H., 2014, p. 2). To deal with this situation, developed countries could give more opportunities and votes for small businesses within their own countries and in developing countries. Institutions like the IASB and the Securities and Exchange Commission (SEC) could implement more field studies so developing countries are included. By this way, the creation of standards could become a more inclusive and collaborative effort, which will likely decrease the occurrence of carve-outs around the world.

Ultimately, the future success of worldwide IFRS adoption will depend on how the IASB and standard-setters work together to recognize, address, and resolve the issue of carve-outs.

References

- Barth, M. E., Landsman, W. R., Young, D., & Zhuang, Z. (April 10, 2014). Relevance of Differences between Net Income based on IFRS and Domestic Standards for European Firms. *Journal of Business Finance & Accounting*, 41 (3-4), 297-327. doi: 10.1111/jbfa.12067
- Biancone, P. P. (2013). The Financial Statements of BRIC Countries. *GSTF Business Review*, 3(1), 8. doi:10.5176/2010-4804_3.1.281
- Blake, J., & Gao, S. S. (Eds.). (2013). Perspectives on accounting and finance in China. Routledge. *Contemporary Accounting Research*, 30(1), 139-175. Retrieved from <https://books.google.com/books?hl=en&lr=&id=XNtJAgAAQBAJ&oi=fnd&pg=PP1>
- Brackney, K. S. & Witmer, P. R. (November, 2005). The European Union's Role in International Standards Setting: Will Bumps in the Road to Convergence Affect the SEC's Plans? *The CPA Journal*, 75 (11), 18. Retrieved from <http://www.nysscpa.org/cpajournal/2005/1105/infocus/p20.htm>
- Carvalho, L. N., & Salotti, B. M. (2013). Adoption of IFRS in Brazil and the Consequences to Accounting Education. *Issues In Accounting Education*, 28(2), 235-242. doi:10.2308/iace-50373
- Chen, C., Young, D., & Zhuang, Z. (2013). Externalities of Mandatory IFRS Adoption: Evidence from Cross-Border Spillover Effects of Financial Information on Investment Efficiency. *The Accounting Review*, Vol. 88, No. 3, pp. 881-914. doi: <http://dx.doi.org/10.2308/accr-50384>
- Devi, S.S., & Samujh, H. (January 2014). The political economy of convergence: The case of IFRS for SMEs. *Australian Accounting Review*. Retrieved from <http://hdl.handle.net/10289/9091>
- Deloitte (July 2005). Amendment to IAS 39 – The Fair Value Option. *Deloitte*. Retrieved from <http://www.iasplus.com/en/binary/iasplus/0507fvo.pdf>

- Doupnik, T. & Perera, H. (2015). *International Accounting, Fourth Edition*. New York, NY: McGraw-Hill Education.
- Guggiola, G. (2010). IFRS Adoption in the E.U., Accounting Harmonization and Markets Efficiency: A Review. *International Business & Economics Research Journal*, 9 (12), 99-112. Retrieved from <http://cluteinstitute.com/ojs/index.php/IBER/article/viewFile/350/339>
- Horton, J., Serafeim, G., & Serafeim, I. (2013). Does Mandatory IFRS Adoption Improve the Information Environment? *Contemporary Accounting Research*, 30(1), 388-423. Retrieved from <http://onlinelibrary.wiley.com/doi/10.1111/j.19113846.2012.01159.x/full>
- IAS Regulation. (2015, March). *European Commission: Banking and Finance*. Retrieved from http://ec.europa.eu/finance/accounting/legal_framework/ias_regulation/index_en.htm
- IFRS 9 Financial Instruments: Status Update. (2011). *Deloitte*. Retrieved from <http://www.iasplus.com/en/binary/dttpubs/1108ifrs9status.pdf>
- IFRS 9 Financial Instruments – Classification and Measurement. (May, 2014). *BDO International*. Retrieved from http://www.bdointernational.com/Services/Audit/IFRS/Need%20to%20Know/Documents/NTK_IFRS9_CM_print.pdf
- IAS 36, Impairment of Assets. (2004). *IAS Plus*. Retrieved from <http://www.iasplus.com/en/standards/ias/ias36>
- IAS 39 Hedging: Aligning theory with practice. (February, 2005). *PricewaterhouseCoopers (PwC)*. Retrieved from <https://inform.pwc.com/inform2/content?action=resource&id=0000000586568369.pdf>.
- IAS 40, Investment Property. (December 2013). Retrieved from <http://www.iasplus.com/en/standards/ias/ias40>
- IFRS and CPCs - The new Brazilian accounting environment. (2010, October 1). Retrieved April 5, 2015, from <https://www.pwc.com.br/pt/ifrs-brasil/assets/booklet-ibri-11-ingles.pdf>
- IFRS in the EU: what research tells us. (December, 2014). *Institute of Chartered Accountants in England and Wales: Financial Reporting Faculty*. Retrieved from <http://www.icaew.com/en/technical/financial-reporting/information-for-better-markets/ifbm-reports/the-effects-of-mandatory-ifrs-adoption-in-the-eu>
- IFRS Foundation. (2015, March 3). IFRS Application Around the World Jurisdictional Profile: Brazil. Retrieved April 5, 2015, from <http://www.ifrs.org/Use-around-the-world/Documents/Jurisdiction-profiles/Brazil-IFRS-Profile.pdf>
- IFRS Outlook: IFRS Issues for Business Leaders (May, 2012). *EY*. Retrieved from

[http://www.ey.com/Publication/vwLUAssets/Outlook_May2012/\\$FILE/Outlook%20May%202012.pdf](http://www.ey.com/Publication/vwLUAssets/Outlook_May2012/$FILE/Outlook%20May%202012.pdf)

- Jermakowicz, E. K., & Gornik-Tomaszewski, S. (2006). Implementing IFRS from the perspective of EU publicly traded companies. *Journal of International Accounting, Auditing and Taxation*, 15, 170-196. doi:10.1016/j.intaccaudtax.2006.08.003
- Jiang, G., & Penman, S. (2013). A fundamentalist perspective on accounting and implications for accounting research. *China Journal of Accounting Research*, 6(4), 233-245. Retrieved from <http://link.springer.com/article/10.1007/s12525-013-0132-8>
- Lemes, S., Santos, L., & Rodrigues, N. (2013). Financial Statement Comparability: Empirical Evidence From Brazil. *Journal of Modern Accounting and Auditing*, 9(5), 587-601. Retrieved from <http://www.davidpublishing.com/show.html?12802>
- Lopes, A. B., & Walker, M. (2012). Assets revaluations, future firm performance and firm-level corporate governance arrangements: New evidence from Brazil. *The British Accounting Review*, 44, 53-67. doi:10.1016/j.bar.2012.03.007
- Macedo, M. S., Machado, M. R., Machado, M. V., & Mendonça, P. C. (2013). Impact Of Convergence To International Accounting Standards In Brazil On The Informational Content Of Accounting. *Revista De Educação E Pesquisa Em Contabilidade*, 7(3), 214.
- Mert, I. (2014). Perceived Costs and Benefits of IFRS Adoption of Cross-Border Mergers: A Statistical Analysis of Indian and Chinese Companies. *Acta Universitatis Danubius, (Economica)*, 10(1), 108-127. Retrieved from <http://journals.univ-danubius.ro/index.php/oeconomica/article/view/2160/2061>
- Obradovic, V. (December 22, 2014). Inconsistent Application of International Financial Reporting Standards. *Economic Horizons*, 16 (3), 231-243. doi: 10.5937/ekonhor14032390
- Onali, E. & Ginesti, G. (August 2014). Pre-adoption market reaction to IFRS 9: A cross-country event-study. *Journal of Accounting and Public Policy*, 33 (16), 628-637. doi:10.1016/j.jaccpubpol.2014.08.004
- Pacter, P. (2014). Global Accounting Standards— From Vision to Reality. *The CPA Journal*. Retrieved from <http://www.ifrs.org/alerts/publication/documents/2014/cpa-journal-global-accounting-standards-january-2014.pdf>
- Ramanna, K., & Sletten, E. (2014). Network Effects in Countries' Adoption of IFRS. *Accounting Review*, 89(4), 1517-1543. Doi:10.2308/accr-50717
- Santana, V. D. F., Sarquis, R. W., Lourenço, I., Salotti, B. M., & Murcia, F. D. R. (2014). Economic Effects of IFRS Adoption in Brazil: An Empirical Analysis of Stock Price Synchronicity. Available at SSRN: <http://ssrn.com/abstract=2383363> or <http://dx.doi.org/10.2139/ssrn.2383363>

- Santana, V. D. F., Rathke, A. A. T., Lourenço, I., & Dalmácio, F. Z. (2014). IFRS Accounting Quality in Latin America: A Comparison with Anglo-Saxon and Continental European Countries and the Role of Cross-Listing in the US. *Social Science Research Network*. Available at SSRN 2438268. Retrieved from http://papers.ssrn.com/sol3/papers.cfm?abstract_id=2438268
- Verriest, A., Gaeremynck, A., & Thornton, D. B. (2013) The Impact of Corporate Governance on IFRS Adoption Choices. *European Accounting Review*, 22 (1), 39-77. <http://dx.doi.org/10.1080/09638180.2011.644699>
- Zehri, F., & Chouaibi, J. (2013). Adoption determinants of the International Accounting Standards IAS/IFRS by the developing countries. *Journal of Economics, Finance and Administrative Science*, 18, 56-62. Retrieved from <http://www.scielo.org.pe/pdf/jefas/v18n35/a02v18n35.pdf>

**INTERNATIONAL FINANCIAL REPORTING STANDARDS
(IFRS) TRANSPLANTING AND CONVERGENCE IN
NIGERIA: CONSEQUENCES AND PROSPECTS - Akinde, M.
A.¹, Afolabi, Adegboyega², & Amusa, N. A.³**

*** ACCOUNTANCY DEPARTMENT THE FEDERAL POLYTECHNIC
ILARO OGUN STATE**

1
2
3

International Financial Reporting Standards (IFRS) Transplanting and Convergence in Nigeria: Consequences and Prospects

Akinde, M. A. (FCA)*, Afolabi, Adegboyega (FCA), and Amusa, N. A. (ACA)**

Abstract

Accountancy profession across the world has been witnessing revolution for sometimes now, the case of Enron and World com are still fresh in mind across the world; another breaking point has also been added, IFRS transplanting and convergence in Nigeria, a standard that has not yet adopted in the United States of America. The specific of objective of the paper is to evaluate the consequences of the convergence with a view to pointing out what per adventure have not been done right in the transplanting, suggest what should be done to enable the country derive the full benefits of the change in the accounting regulation. The data are collected through primary data apparatus and panel secondary data from the annual reports of the selected case studies. The methodology adopted is student-t distribution. We also deployed descriptive statistics. The results from the descriptive statistics portend mix reactions. Most of the variables selected have both positive and negative signs; when it is positive, it means that the amount reported in the financial statements under GAAP is higher than that of IFRS and vice versa. The student-t portends that at 5% confidence interval, there is significant difference between the figures reported under IFRS and GAAP, consequently the convergence of IFRS in Nigeria has offered invaluable benefits and significant effects. We however recommend that government should immediately review all the relevant sections in the local extant laws (i.e. Companies and Allied Matter Act (CAMA), Insurance Act etcetera) and put in place necessary machinery to facilitate training of the University, Polytechnic and University accounting lecturers; in particular the syllabus of School Certificate examination and Joint Admission Matriculation Board Examination (JAMB) in Principles of Accounts should be reviewed urgently to have the unity of purpose and to derive optimum benefits in the convergence of IFRS in Nigeria.

Keywords: IFRS Transplanting, Convergence, Panel Secondary Data, GAAP, Mix Reaction, CAMA and JAMB.

*** Principal Lecturer, Accountancy Department, The Federal Polytechnic Ilaro, Ogun State, ACIT, HND Accounts, B. SC. and M. SC. Economics and M. SC. Finance, Ph.D Finance In-View (Covenant University, Ota Ogun State). ****

**** Lecturer, Accounting Department, College of Management Sciences, Crescent University, Abeokuta Ogun State, Ph.D In-View, Babcock University, Ogun State.**

***** Principal Lecturer, Banking and Finance Department, The Federal Polytechnic Ilaro, Ogun State, B. Sc. Banking and Finance and M. Sc. Finance.**

1.1 Introduction

Recently, Nigeria has converged on the use of International Financial Reporting Standards (IFRS) in the preparation of Financial Statements of Significant Public Entities. The implementation started in 2012, 2011 and 2010 are the comparative years. On convergence/adoption in Nigeria, many entities that fall under Significant Public Entities (SPEs) have converged in 2012 while some few ones, for example, Micro Finance banks are struggling to converge with the use of IFRS, perhaps because the Central Bank of Nigeria (CBN) has not given specific directives on convergence with IFRS to the Micro Finance Banks. Some African countries and other developed nations across Europe, Australian, and Asia among others have adopted the International Financial Reporting Standards (IFRS) as reporting standards. The transformation from local Generally Accepted Accounting Principles (GAAP) to IFRS represents the most crucial revolution in Accountancy profession. In the work carried out of Ogiedu and Odia (2013), more than 120 countries are reported to have converged with the use of IFRS as issued by the International Accounting Standard Board (IASB). It is believed that the adoption of IFRS will enhance comparability, universality and production of high quality Financial Statements. (Okafor and Ogiedu 2011, Collings, 2012 and Akinde, 2014). Similarly, Ball (2006) as also affirmed in Okafor and Ogiedu (2011), submit that the convergence of IFRS among several nations across the world will reduce differences in the reporting languages. However, these differences in reporting languages, cannot be eliminated. They maintained that the adoption of the IFRS, perhaps would not ensure comparability of financial statements in all countries as suggested because the country will still need to comply with the relevant local extant laws. Ball (2006), Berth, Landeman and Lang (2006), Okafor and Ogiedu (2011), Christensen, and Nikoleieu (2008) and Suche and Jindrichovska (2004)). Besides, the adoption of IFRS will reduce window dress financial statements, consequently, there will be production of high quality annual reports. (Akinde, 2014, Collings 2012).

The specific objective of the paper is to evaluate the financial effect and consequences of adopting the IFRS in Nigeria. To achieve this, secondary data were collected from quoted companies in the Nigerian stock market. They were analysed using both descriptive and inferential statistics.

1.2 Background to the Study

GAAP in Nigeria before the adoption of IFRS includes the Statement of Accounting Standards (SAS), the International Accounting Standards (IAS), Insurance Act, Bank and Other Financial Institution Act and other local extant laws, (e.g. Companies and Allied Matter Act 1990 as amended to date, Central Bank of Nigeria Regulations, Insurance Act 2014 etcetera). However, with the adoption of IFRS in Nigeria, GAAP is now re-defined as the IFRS/IAS and other extant local laws that do not contravene with the International Standards. Nigeria seems not fully ready for the adoption of these international standards. This is because the Companies and Allied Matter Act (CAMA) 1990 as amended to date still has the format and several other important laws that affect the preparation and presentation of financial statements of limited liability Company in Nigeria. Surprisingly as at today, these extant laws have not been amended to accommodate the changes made in IFRS. Amending these laws will eliminate contradictions in presentations, accommodate fair value of assets, treatment of goodwill and other intangible assets, valuation of noncurrent assets, business combination among others. Most Micro Finance banks, which should have complied fully with IFRS since 2012 under Significant Public Entities (SPEs) have not done so and no sanctions have been given for non-compliance. Financial statements some of the SPEs and Small and Medium Scale Enterprise (SMEs) are still being produced using local standards. They still file returns with Financial Statements prepared under local GAAP to the regulatory agencies like the Central Bank of Nigeria (CBN), Nigeria Deposit Insurance Corporation (NDIC), and Federal Inland Revenue Service (FIRS) among other regulatory institutions without commensurate sanctions. This contradicts IFRS that has been adopted with directives from the Federal Executive Council (FEC) in Nigeria on 28 July, 2010 that all entities under SPEs are to prepare Financial statements in 2012 by adopting the IFRS fully and Small and Medium Scale to comply in 2014. Presently, we are in the year 2015, unfortunately, many of these SPEs eg Micro Finance Banks have not converge with IFRS.

Awareness in the tertiary institutions studying Accounting, Finance and Banking Business related courses are quite low. Many lecturers are still imparting accounting knowledge to students on the premise of the local standards. The curriculums of accounting courses are not yet reviewed in the tertiary institutions in Nigeria. Certainly, if we continue this way, our accounting graduates may not be able to compete for example with graduate accountants from European tertiary institutions where the curriculum reflects current trend in the profession. In the

secondary schools, it is worst possible scenarios. These levels of accounting education are not even aware of the IFRS; the West Africa Examination Council (WAEC), National Examination Council (NECO), Joint Matriculation Examination Board (JAMB) offering subjects in financial accounting related examinations are still carried out using Statement of Accounting Standard and other local extant laws.

The paper intends to investigate effect the of transition from local GAAP to IFRS in Nigeria on entities profitability, performance fundamentals, assets, liabilities and other information contained in the Financial Statements of selected entities from different industrial sectors in 2011, which is the comparative year. The relevant research question is what is the effect or impact of IFRS convergence/adoption on Financial Statements in spite of the challenges and the problem statements stated in the preceding statements?

2.0 Literature Review

IFRS Convergence signifies the process by which standard setters across the world discuss accounting issues, using their combined experiences in accounting profession to arrive at the most appropriate solution. Gassen and Sellhorn (2006) submits that convergence could be either by adoption that is, a complete replacement of national accounting standards with IASB's standards. This was what we did in Nigeria. We transplanted IFRS without evaluating the states of preparedness of government institutions such as Federal and State Inland Revenue Service, Tertiary institutions studying accounting, West African Examination Council (WAEC), National Examination Council (NECO), Joint Admission Matriculation Board (JAMB). Convergence could also be by adaptation, which is modification of IASB's standards to suit peculiarities of local market and economy without compromising the accounting standards, disclosure requirements of the IASB's standards and the basis of reaching conclusions. Convergence was meant to bring standards of the US GAP and IFRS closer or harmonize them; to produce identical standards. According to SEC (2010), there are two approaches to IFRS adoption around the world: convergence and endorsement approaches.

There are several countries in Africa, Europe, Asia and Australia among others that have converged with IFRS as issued by the IASB. Even the United States Securities and Exchange Commission (SEC) is considering permitting US entities to prepare financial statements in conformity with the IFRS. There appears to be huge benefits for countries that have adopted the IFRS. However, Ashbaugh and Pincus (2001) maintain that it would take some time before the benefits of IFRS can be fully realized. Suche and Jindrichovska (2004) find out that at the transition period, accounting earnings had a positive small but significant

relationship on total assets, total liabilities and equities of the sampled entities. It indicates that Return on Assets (ROA) is relatively higher and significant under IFRS than under local GAAP. From our study, it appears that total assets, total liabilities and accounting earnings after the adoption of IFRS are smaller in the sampled entities in Nigeria. This study takes a different queue because the performance proxies choosing from the Financial Statements have mix effects. Some of these accounting variables rose in values while some other items decreased in values after convergence with the IFRS issued by the International Accounting Standards Board (IASB). The reasons are not farfetched. They include reclassification of assets and liabilities (both current and noncurrent assets, current and noncurrent liabilities), impairments, fair values and possible window dressed Financial Statements when GAAP was used to prepare the Financial Statements.

Financial Statements of an entity provides information about performance, position and liquidity. A high quality Financial Statement is essential for users of such information to make major economic decisions. (Iyoha and Faboyede, 2011, Collings, 2012 and Akinde, 2014). Countries across the world continue to converge with IFRS. It is therefore imperative to measure the quantitative effect of convergence of IFRS in the preparation of a general purpose financial statement. The findings of Okafor and Ogiedu (2011) reveal that IFRS has been adopted in Nigeria, however a fraction of the entities have not complied. This is also corroborated in this study. Surprisingly, most private companies that fall under Significant Public Entities (SPEs) in Nigeria from the transition guidelines, have yet to complied. The study of Gassen and Sellhorn (2006). Haller and Eierle (2004), and Hung and Sabramanyam (2007) also exhaustively measure the benefit after convergence to IFRS in relation to local GAAP in Europe. However, Suche and Jindrichovska (2004) infer that consolidated financial statements of some selected entities in France are not as significant as it should have been contrary to a priori expectations. The study made by Jemakowicz (2004) in Belgium shows improved and better results and significant effect when Financial Statements produced after IFRS are compared with those statements produced employing local GAAP of Belgium. Furthermore, Suche (2004) in Australia reveal that after IFRS, total liabilities and equity of the selected firms decrease; more firms also have decrease in their earnings. In the position maintained by Haller and Eierle (2004), earnings of firms become value relevant after conversion to IFRS than before conversion; the equity book value is not value relevant as it remains at the same level when IFRS is adopted in the preparation of entity's Financial Statements.

2.1 Financial Statements Architecture after Convergence to IFRS in Nigeria

Jermkowicz (2004) submit that all accounting standards have consequences otherwise there will not be the need to issue such standards. The nature and architecture of Financial Statements have been reshaped and reorganized to take the interest of users of Financial Statements after adoption of IFRS within the short time in Nigeria. The financial statements after the transition to IFRS by the Significant Public Entities (SPEs) now run into several pages to produce invaluable information to assists users of such statements in taken major economic decisions. However, the important question to ask here is whether the users of these financial statements will really understand the bulky information contained in the statements without a financial analyst. This is a crucial question, this is because the information in such statements may mislead the users of these annual reports. The challenges after the convergence are overwhelming. They include personnel to prepare and convert the financial statements of first time adopter from the local GAAP to fully complied IFRS financial statements. In the academia, the syllabuses of accounting, finance and other business courses still remain as they were before the convergence to IFRS in 2010. In fact there has been no awareness at the secondary school level. Pupils studying accounts at basic level still continue be at the mercy of their teachers who do not have any knowledge of IFRS. The pupils in these secondary school are the major source of inputs at the tertiary levels. Thus the challenges of producing world class IFRS compliance accountants may be a mirage as efforts are not focused on both the basic and advanced level of accounting as a discipline in Nigeria. Various councils involved in the examination of financial accounting seem not to be aware of the wind of change in accounting profession consequent upon the adoption of IFRS in Nigeria. They have not responded by changing the outdated syllabus.

To this end, the findings of Suche and Jindrichovska (2004) are quite fascinating. The adoption of IFRS will produce invaluable Financial Statements that will be more useful to the auditor, analysts, standard setters and academia. To achieve these results, relevant government institutions should wake up to review syllabuses so as to develop the required personnel that will carry accounting and financial services in accordance with the tenets of IFRS as issued by the IASB from time to time. .

2.2 The Consequences, Effect and Challenges of IFRS in Relation to local GAAP

In the recent time, there is a general push towards the convergence of IFRS, the regulations issued by IASB. The basic effect of this on Financial Statements is that the convergence will ensure comparability, reliability, relevance, verifiability and that the information contained in the statements are faithfully represented. (Okafor and Ogiedu (2011), Akinde, 2014, Trade across international boundaries continue to demonstrate a positive significant trend since the language of recording business transaction in the Financial Statements is now universal; this facilitates comprehension of the statements.

There are abundant literatures and evidences in international accounting on the quality and economic consequences of adopting IFRS. Okafor and Ogiedu (2011), Young and Guenther (2002), Land and Lang (2002), Watts(1998 a and b), Ball(2006), Suche and Jindrichovska (2004) reveal consequences such as decrease in cost of funds, optimal equity deployment, improved mobility of capital across international boundaries and decrease in information asymmetry as only necessary information are provided to users of Financial Statements. Also, quality information to equity holders will improve; results of entities will be more transparent, reduction in window dress Financial Statements efficient management of international business operations, and positive effect on business performance management.

However, there are challenges of adopting IFRS. These include huge conversion costs, training and retraining costs and human capital development, cost of upgrading accounting software, cost of producing voluminous IFRS financial statements especially if they are in hard copies and the Small Scale and Medium term enterprises cost affordability among others. No matter what these challenges are, Iyoha and Faboyede (2011) conclude that the benefit will always greater than the costs

3.0 Empiricism, Instrumentation and Methodology

This paper investigates the effect and consequences of change from local GAAP in the preparation of Financial Statements to IFRS in Nigeria using entities' Properties, Plant and Equipment (PPE), Inventory, Trade Receivables, Other Receivables, Total Assets and items of Equity, Liabilities and Earnings. We compared the figures before adoption and after the adoption of IFRS with a view to measuring deviation from the reported figures in 2011 and 2012. The instrument adopted is descriptive statistics and inferential statistics using student-t distribution. Panel data for the year 2012 and 2011 were collated from the annual reports of ten (10) quoted companies from the Nigeria Capital Market are collated. Six (6) of these companies are in the real sector, that is manufacturing entities, one(1) company from the construction and three(3) from the food and beverages. This is used to compute the percentages in table 1.

These ten (10) companies have converged with IFRS in 2012 and their comparative years are 2011. The paper finds the differential of figures stated in the Financial Statements before the conversion using the local Generally Accepted Accounting Principles (GAAP) and figures stated after convergence with IFRS in percentage. The base year is represented with amount stated in 2011 using the local GAAP. The percentage is defined as GAAP figures in 2011 minus IFRS figures in 2012 divided GAAP figure in 2011 (i.e, figure for the base year) multiply by 100. From the table 1 below, the manufacturing company is represented with MAN, (i.e. manufacturing), transaction is represented with TRANS. Thirteen (13) items were selected for each of the ten companies in three (3) different sectors. We also collated data from the Annual Reports of fifteen (15) companies from the Financial Statements of financial institution, thirteen (13) from the banking sector and two (2) from the insurance sector. This is used in table 2 to 6 to measure the mean and standard deviation, which are used to calculate student-t distribution of the empirical models.

Table 1:

The Effect of adopting International Financial Reporting Standards in the Real Sector: Comparative Year 2011											
Assets											
	TRANS	MAN	MAN	MAN	MAN	MAN	MAN	CONS	FOOD	FOOD	FOOD
		1	2	3	4	5	6	7	8	9	10
Noncurrent Assets		%	%	%	%	%	%	%	%	%	%
Prop. Plant & Equip. (PPE)	1	2	2	-1	2	-1	3	3	-3	2	1
Inventory	2	1	2	4	-2	-2	-2	-2	2	-2	-2
Trade receivables	3	3	3	-2	4	1	-1	-1	-1	3	1
Other receivable & prep.	4	2	2	3	4	4	4	0	3	2	2
Total current assets	5	2	3	4	3	4	1	2	4	3	2
Total assets	6	10	12	8	11	6	5	2	5	8	4
Equities and liabilities											

Equity	7	0	0	0	0	0	0	0	0	0	0
Retained earnings	8	4	2	2	3	6	2	1	-2	-2	1
Other comp. of equity	9	0	0	0	0	0	0	0	0	0	0
Total equity	10	4	2	2	3	6	2	1	-2	-2	1
Total Non-current liabilities	11	4	5	2	4	-4	-1	-1	4	5	-1
Total current liabilities	12	2	5	4	4	4	4	2	3	5	4
Total equity and liabilities.	13	10	12	8	11	6	5	2	5	8	4
Profit after income tax	14	3.91	2.82	- 3.83	- 1.52	2.33	2.01	-1.56	3.41	2.66	-1.02

Sources: Compile by the researchers from the annual reports of selected companies in 2011 and 2012

Table 2: Descriptive Statistics

Pair	Average/ Mean	Standard Deviation
GAAP	10032046.48	17950264.8 82
IFRS	7909324.22	15313222.7 58

Table 3: Standard Deviation and Variation in Mean

Pair	Mean Difference	Standard Deviation Difference	T	Df	P Value	α Level
GAAP – IFRS	3134755.170	13140478.712	2.021	121	0.002	0.05

Table 4: Pair Sample Correlation

Pair	N	Correlati on	Sig.
GAAP & IFRS	144	.778	.000

4.5 Specification of Empirical Model:

$$\begin{aligned}
 1. \quad t &= \frac{\hat{\alpha}}{\text{Se} \left(\hat{\alpha} \right)} \\
 &= \frac{7909324.22}{15313222.758} = 0.5165029168
 \end{aligned}$$

$$\begin{aligned}
2. \quad t &= \frac{\beta}{\text{Se} \left(\hat{\beta} \right)} \\
&= \frac{10032046.48}{17950264.88} \\
&= 0.5588801361
\end{aligned}$$

Hypothesis 1:

Ho₁: There is no significance difference between IFRS and existing GAAP figures stated in the financial statements of the selected companies.

Condition: we reject Ho₁, if p value is less than α level (0.05)

Hypothesis 2:

Ho₂: IFRS convergence did not provide significant benefit than existing GAAP in Nigeria.

Condition: we reject Ho₂ if the mean and standard deviation value of GAAP is less than IFRS value.

Table 5: Summary of live Presentation of the Empirical Model

Hypothesis Testing	Condition	Decision
There is no significance difference between IFRS and existing GAAP figures stated in the financial statements of the selected companies.	Reject H_0 , if p value is less than α level (0.05).	Reject the null hypothesis and we therefore accept the alternative hypothesis.
IFRS convergence did not provide significant benefit than existing GAAP in Nigeria	Reject H_0 , if the mean and standard deviation value of GAAP is less than IFRS value.	Reject the null hypothesis and we therefore accept alternative hypothesis.

Source: model live result for the study.

Interpretations and Discussion of Findings

In table 1, PPE, other assets, equity, liabilities and profit after taxation are compared employing descriptive statistical apparatus in form of percentages. The table gives credence to the trend in the rate of increase or decrease of the value of items selected. It shows at a glance whether there is an increase or decrease in the figures reported in the financial statements of the selected companies under GAAP and IFRS. The positive signs indicate that GAAP figures are higher than IFRS figure. Whereas the negative signs imply that the amount reported under IFRS is higher. The table portends that there is a mix effect, some items increase in value while others reduce in value. For example, Property, Plant and Equipment (PPE) of the Company in item 1, 2, 4, 6, 7, 9 and 10, we have positive signs, which imply that the figures of PPE reported under GAAP are greater than figures reported under the IFRS; in 3, 5 and 8 they are negatives, which means that the amount stated in IFRS Financial Statements are more than the amount stated using the local GAAP. This shows that the adoption of IFRS in Nigeria has great consequences on the amount reported in the Financial Statements. The possible reasons for this are impairments as contained in IAS 36 and valuation model as stipulated in IAS 16 on PPE, which were not in the previous local Statement of Accounting Standards. All items in the financial statements are reclassified on convergence to IFRS. This further explains the change in the values of the items stated in the financial statements prepared after the convergence

to the standards issued by the International Accounting Standard Board (IASB).

In Table 3, we reported the descriptive Statistics. In Table 2 and 4, we measure the relationship between GAAP and IFRS with the use of Student-t test correlation. This portends that there is mean differential of 3134755.170 and standard deviation of 13140478.712. The probability value calculated is 0.04. It should be noted that the p value of 0.04 is smaller than α level (0.05), therefore we reject the null hypothesis and accept alternative hypothesis. We can therefore infer that there is significant differences between the mean and the standard deviation for the amount reported in financial statements prepared under IFRS and GAAP. In table 2 reported above, the mean of GAAP is 100332046.28 with standard deviation of 17950264.882; that of IFRS is 7909324.22 with standard deviation of 15313222.758 It means that there is a small alteration from GAAP to IFRS. Consequently, the alternative hypothesis is accepted, we deduce that IFRS provides smaller advantages than existing GAAP in Nigeria. Also, from table 4 reported above, there is correlation of 0.778 between GAAP and IFRS, we can therefore infer a strong positive relationship between GAAP and IFRS. Similarly, the student-t test correlation shows that there is significance relationship between the GAAP and IFRS with the mean difference of 3134755.470, p value of 0.02 and α level of 0.05. Since 0.02 is less than 0.05, the alternative hypothesis is accepted, it therefore means that there is strong positive association between the GAAP and IFRS. The analysis gives credence to the fact that both IFRS and GAAP provide Greater benefit in Nigeria, but for the slight variation in the figures reported using IFRS, we can deduce that the adoption of IFRS has great effect and consequences in taking major economic decision about an entity.

4.0 Conclusion

From the descriptive analyses made in section 3 of the paper, it is apparent that assets, liabilities and earnings of the entities selected rose in some companies and it reduced in the other entities. Thus, there is both positive and negative effect on financial statements after convergence to IFRS by the Significant Public Entities (SPEs) within the shortest possible time of conversion. However, the trends should be examined after some years using inferential statistics like regression and chi square analyses so as to determine how significant these values are using relevant s. From t-statistics computed from the panel data, the hypotheses reveal that IFRS

adoption in Nigeria has great effect and consequences in the preparation of Financial Statements, these have effect on major economic decisions taken by both existing and potential investors in an entity.

5.0 Policy Recommendations

a. It is recommended that all entities under SPEs should as a matter of urgency converge with IFRS so that they can fully reap the benefits of using IFRS. The Central Bank of Nigeria should as a matter of urgency directs Micro Finance Banks to converge with IFRS since they are within the definition of SPEs and the account of the Small and Medium Enterprises should also converge with IFRS in 2014.

b. Relevant government institutions for example, the Federal Inland Revenue Service (IFRS), State Inland Revenue Service (SIRS), Corporate Affairs Commission (CAC), Central Bank of Nigeria (CBN) etcetera should be well trained and henceforth not accept financial statements prepared using local GAAP. This will ensure that entities are compelled to prepare financial statements using IFRS.

c. More attention should be given to the development of accounting profession from the grass root. The National Universities Commission (NUC), National Board for Technical Education (NBTE) and their counterparts in Colleges of Education including West African Examination Council (WAEC), National Examination Council (NEC), Joint Admission Matriculation Board (JAMB) and professional bodies should as a matter of urgency review curriculum of Accounting, Finance and other related business courses to be in line with the IFRS.

c. The Financial reporting Council (FRC) should as a matter of fact organise training for academic and non teaching staff of the Universities, Polytechnic and Colleges of Education and teachers of Account, Commerce and Business Studies in Secondary school. This will facilitates production of a world class accountant that will be able to practice anywhere in the world. Besides, it will enhance Human capital development in the discipline.

d. The Small and Medium Scale Enterprises are to converge to IFRS in the accounting year end 2014, more efforts should be made by the FRC to create more awareness and sensitization programme on full adoption of IFRS and IFRS for SMEs. This becomes necessary to reduce conversion cost as many SMEs cannot afford cost of conversion using full IFRS.

References

Ashbaugh, H. and Pincus, M. (2001). "Domestic Accounting Standards and Predictability of Earnings", *Journal of Accounting Research*, 39, 417-434

Akinde M. A. (2014). ***Workout Partnership Financial Statements and Miscellaneous Accounts***, Olas Print, shomolu Lagos.

Ball, R.(2006). "International Financial Reporting Standards (IFRS), Pros and Cons for Investors". *Accounting and Business Research*, Investment and Accounting Policy Forum, 5-27

Barth, M. G. , Landeman, W. and Lany, M . (2006)."International Accounting Standards and Accounting Quality", Working Paper. Stanford University and University of North Carolina at Chapel Hill

Christensen, H., and Nikoleieu, V. (2008). "Who Uses Fair Value Accounting for Non Financial Assets following IFRS Adoption, Working Paper university of Chicago

Collings, Steven(2012). ***IFRS for Dummies***, John Willey & Sons Limited, England

Committee on Roadmap (2010). Report on the Adoption of International Financial Reporting Standards (IFRS) in Nigeria.

Demaki, G. O. (2013). "Prospects and Challenges of International Financial Reporting Standards to Economic Development in Nigeria". *Global Journal of Management and Business Research*. Volume XIII Issue I Version I.

Gassen, J. and Sellhorn, T. (2006). "Apply IFRS in Germany- Determinants and Consequences", *Betriebswirtschaftslehre für Schung and Praxis*

Haller, A. and Eierle, B. (2004). "The Adoption of German Accounting Rules to IFRS: A legislative Balancing Act", *Accounting in Europe*, 27-50

Hung, M. and Subranayanm, K.(2007). (2007). "Financial Statements Effect of Adopting International Accounting Standards: The Case of Germany", *Review Accounting Studies*, 12(4): 623-657.

IASB (2009). International Financial Reporting Standards (IFRS) for Small and Medium size Enterprises (SMEs). London: IASB

IASB (2010). Financial Statement Presentation. *Website September 9, 2010:*

<http://www.ifrs.org/Current+Projects/IASB+Projects/Financial+Statement+Presentation.htm>

- Iyoha, H. and Faboyede D. (2011). "International Financial Reporting Adoption in Nigeria: Benefits and Consequences", www.google.com
- Jermakowicz, E. K. (2004). "Effect of Adopting International Accounting Standards: The Case of Germany", Working Paper, University of Southern California.
- Land, J. and Lang, M. H. (2002). "Empirical Evidence on Evolution of International Accounting Standards", *Accounting Review*, 77(4): 115.
- Okafor, C. and Ogiedu, K. O. (2011). "Potential Effect of the Adoption and Implementation of International Financial Reporting Standards (IFRS) in Nigeria", *JORIND* 9(2), www.transcampus.Org
- SEC. (2010). Work Plan for the Consideration of Incorporating International Financial Reporting Standards into Financial Reporting System for U.S. Issuers New York, US SEC.
- Suche, P. and Jindrichovska, I. (2004). "Implementing IFRS: A Case of Czech Republic", *Accounting in Europe*, 1: 109:137
- Watts, R. (2003a). "Conservatism in Accounting Part 1: Explanations and Implications", *Accounting Horizons*, 17: 207-221
- Watts, R. (2003b). "Conservatism in Accounting Part II: Evidence and Research Opportunities", *Accounting Horizons*, 17: 287-301.
- Young, D. and Guenther, D (2002). "Financial Reporting Environments and International Capital Mobility", *Journal of Accounting Research*.

ENVIRONMENTAL MANAGEMENT ACCOUNTING TECHNIQUES AND QUALITY FINANCIAL REPORTING IN NIGERIA – Anyanwu, N.

ABSTRACT

Environmental accounting is a key component of corporate social responsibility. There are a number of other terms used to describe this such as 'triple bottom line', 'sustainable development', 'three pillars of sustainability', etc.

There is a debate in business practice and society about the limits of business accountability. Put simply, this concerns three key questions: 'for what should accounting actually account?' 'how should the environmental assets and costs be valued' and 'to whom is a business accountable?'

Purpose/objective

The purpose of this practical paper is to demonstrate how environmental management accounting and reporting is crucial for an organisation to be sustainable. Organisations rely on the environment in order to deliver a service or produce a product but play very little role in ensuring the environment is maintained for future use. Nigeria is endowed with an abundance of natural resources but studies have shown that these resources are rapidly depleting and are not being replaced at the same rate of usage. It has been found that by making companies report on their environmental impact there will be more accountability and sustainability for the environment. The paper will provide a comparative analysis of top UK and Nigerian listed companies and evaluate the extent to which the top Nigerian listed companies report on environmental issues and hence are accountable for their environmental impact.

Research methodology:

The research methods used are an examination of the financial statements of 20/30 (segment) top listed companies representing four key high environmental impact sectors of the economy namely; manufacturing, oil and gas, cement, transport and logistics. Also the role of various accounting bodies are playing in ensuring there are adequate frameworks and structures in place to enable proper corporate environmental accountability. Accountancy bodies researched were ACCA, ICAEW and ICAN. A cross section of Nigerian Accountants both in the UK and Nigeria working within the companies studied or within the industry.

Findings:

It was discovered that majority of Nigerian companies do not effectively report on environmental matters. Those who report minimal or generic information are inconsistent. Thus they are not accountable to their stakeholders for their environmental impact. The reasons for this are numerous but of key importance are the issues around lack of regulation, inability to value the things to be measured, Environmental risks cannot be ignored, they are now as much a part of running a successful business as product design, marketing, and sound financial management.

Policy Implications:

Such a poor record of reporting might impact negatively to the future profitability and sustainability of the corporate entity within the global environment. Lack of accurate reporting could also increase corporate environmental lawsuits.

Recommendation:

It should be made mandatory for such reports to be presented through a process of environmental accounting standards. The regulatory authorities should advise in this direction.

KEY WORDS

ENVIRONMENTAL REPORTING

ENVIRONMENTAL MANAGEMENT ACCOUNTING

ENVIRONMENT IMPACT OF NIGERIAN CORPORATIONS

SUSTAINABLE ACCOUNTING – PEOPLE, PLANET, PROFITS

CORPORATE SOCIAL RESPONSIBILITY OF TOP NIGERIAN CORPORATIONS

ENVIRONMENTAL ACCOUNTING STANDARDS

1.0 INTRODUCTION

This paper will establish the extent to which quality environmental reporting disclosures takes place in Nigerian listed companies in practice. It will also explore the possible reasons for the level of quality of reporting. It is divided into four sections. Section two is the review of relevant literature and theories. Section three is the research methodology used in the study. Section four is the discussion of research findings and conclusion. Section five is the recommendations. It will include some environmental management accounting case studies.

There is an urgent need for organisations to disclose the cost implications of their economic activities in so far as they impact on the environment both positively and negatively. Environmental impacts are by products of business activities which can contribute to the degradation of the environment. If we carry on with the current levels of waste being produced the next 50 years will not be as rich as the last 50. It is imperative that our planet's rich natural resources and environment are preserved for future generations. Therefore companies need to be fully accountable for the true cost of the impact of their activities on the environment.

Low or non-existent reporting on environmental issues actually results in poor quality financial statements being produced as there may be missing or misrepresented information.

Through the literature review and findings, this paper will determine if the three reasons for low level or non-environmental disclosures outlined below hold true in Nigerian organisations

Lack of environment analysis and valuation tools, techniques, knowledge and awareness from the management and finance personnel,

Lack of strong government intervention via legislation, poor enforcement infrastructure and poor standards of measurement.

Inability of stakeholders to have substantial influence over the actions and accountability of organisations and their top management.

Finally, the paper will make the recommendations of how the change should come

Role of accounting bodies in building capacity of accountants (their members) in this area and influencing environmental policy & laws

Policy makers and standard setters need to develop a better environment framework with a wider agenda within which all environment laws will sit. Targets and Key Performance Indicators need to be set for organisations and mandatory reporting on these targets should be required in the annual reports. There also needs to be a strong legal enforcement apparatus set up to penalise the offenders.

2.0 **LITERATURE REVIEW**

Theoretical Framework: What Is Environmental Accounting/Reporting?

Environmental accounting is a key component of corporate social responsibility. There are a number of other terms used to describe this such as 'triple bottom line', 'sustainable development', 'three pillars of sustainability', etc.

'Environmental accounting is the practice of using traditional accounting and finance principles to calculate the costs that business decisions will have on the environment'. K J Henderson (*Houston Business Chronicle*).

For example, a business uses environmental accounting to determine the short- and long-term effects of the decision, such as unemployment in the plant's region. Other examples are leftover manufacturing materials which have to be disposed of as waste. Environmental Accounting is mainly an internal function of management. However, reporting the outcomes or results of such activities is important to enable external stakeholders to make better informed decisions about the status of the company.

Another way to look at environmental accounting is a review of the environmental consequences of an organisation's inputs and outputs. Inputs include the measurement of key environmental resources such as energy, water, resources (including human resources), land use, etc. this is

particularly important if the resources are scarce or threatened. Outputs include the efficiency of internal processes (possibly using a 'yield' calculation) and the impact of outputs. These might include the proportion of product recyclability, tonnes of carbon or other gases produced by company activities, any waste or pollution.

Over the last two decades there has been mounting pressure on companies and particularly large ones to describe and assess the social and environmental effects that their economic activity has. This is also known as of social and environmental 'footprints'. Most countries now have some form of mandatory environmental reporting and disclosures for companies in general and particularly for companies listed on the stock exchange. In addition to the mandatory disclosures, UK companies also make voluntary disclosures using various voluntary reporting frameworks such as the IFC Sustainability Framework (International Finance Corporation IFC is part of the World Bank Group) or the Global Reporting Initiative (GRI) Reporting Framework.

IFC's Sustainability Framework contains Environmental and Social Performance Standards which define its clients' responsibilities for managing their environmental and social risks. It applies to all investment and advisory clients whose projects go through IFC's initial credit review process after January 1, 2012.

The Global Reporting Initiative (GRI) is a non-profit organization that promotes topics of sustainability. It produces global standards for sustainability reporting. The GRI Reporting Framework is intended to provide a generally accepted framework for reporting on an organization's economic, environmental, and social performance using Key Performance Indicators. Over 7500 organisations worldwide use this framework's standards for voluntary reporting.

Some key environmental indicators which should be in Corporate Reports include;

CO2 emissions

Societal impact

Environmental standards

Pollution

Efficiency in use of resources

Human Rights and

Labour practices/decent work

In Nigeria however, environmental reporting and disclosures are entirely voluntary and therefore there is a high level of subjectivity and inconsistency that goes into the disclosures. This means the reader of the annual report does not have the full picture of events in order to make good decisions.

2.2 Redefining Costs For Environmental Purposes

Environmental accounting is a relatively new concept in the accounting arena.

Most companies do not actually know the extent of their environmental costs and thus tend to underestimate them or not even measure them. This leads to distorted calculations of improvement options, asset values, profitability and performance reporting. As such the most significant problem of Environmental Accounting lies in the absence of a clear definition of environmental costs. This means if they are not measuring such costs they are not monitoring and reporting them. It also means they cannot identify opportunities for cost savings and improvements.

For instance, in 2008 Shell claimed it had lost 30,000 barrels or 5 million litres of oil spills in the Bodo community in the Bonny Region of Nigeria which resulted in them offering the local community £4,000 in compensation. A successful legal action against the company in the UK put the figure at almost 3 times that amount 90,000 and resulted in a payout of £55 million. A much bigger environmental cost than they initially predicted.

The definition of environmental costs depends on how a company intends to use the information. Conventional costs are those raw material and

energy costs having economic relevance whereas environmental costs have a clear impact on the environment. However, environmental costs can be seen as potentially hidden costs, opportunity costs, sunk costs, relationship costs or contingent costs (to be incurred at a future date). These costs are sometimes captured by the conventional accounting systems but then are usually lost in 'overheads'. In other areas, how are environmental assets classified and depreciated e.g. land owned for mining, forests where wood is sourced, oceans for water? Should they be classified as depreciable assets or income? What about the cost of deforestation? Who bears that environmental cost?

For example in capital budgeting investing in energy inefficient manufacturing equipment (such as a generator) will possibly result in a higher labour charge, more materials being used and higher energy bills. None of these costs are recorded as environmental costs. Poor product design using inferior materials which could result in human deaths or illnesses are not recorded as environmental costs until maybe there is a compensation payment.

Contingent costs may be incurred at a future date - for example costs for cleaning up oil spills. They are also referred to as contingent liabilities. Image and relationship costs are intangible in nature and include, for example, the costs of producing environmental reports.

The costs associated with an organisation being seen to behave in an irresponsible manner by the public can also be quite a significant unplanned environmental cost. The 1995 infamous planned dumping of the Brent Spar floating oil storage facility incident off the coast of Scotland cost Shell millions of pounds in terms of lost revenues via the resultant consumer boycott. The recent 2015 boycotting of MTN in Nigeria over the xenophobia in South Africa is also an example of the powerful influence that environmental concern has in today's business environment.

The United Nations Division of Sustainable Development UNDS (2003) described total corporate environmental costs as environmental protection costs (emission treatment and pollution prevention) plus costs of wasted materials, plus costs of wasted capital and labour. Waste in this context means production inefficiency (purchase value of non-material output). UNDS stated that wasted materials account for 40% to 90% of environmental costs according to a survey. One should recognise that

environmental costs are not a separate type of cost; rather they are part of money flowing throughout a corporation.

In summary, the main difficulty associated with environmental costs is their identification and allocation. Conventional accounting systems wrongly classify environmental costs as overheads and this results in them being hidden from management and hence monitoring and reporting disclosure. A number of accounting bodies have issued discussion papers with suggestions on the way forward in this area. Environmental Management Accounting (EMA) attempts to make all relevant, significant costs visible so that they can be considered when making business decisions.

2.3 The Tools And Techniques For Environmental Management Accounting

The United Nations Division of Sustainable Development UNDS (2003) identified the four management accounting techniques which are useful for the identification and allocation of environmental costs as: input/output analysis, flow cost accounting, activity-based costing (ABC), and lifecycle costing. They are discussed briefly below.

a) Input/output analysis

The input/output analysis is a technique that can provide useful environmental information, sometimes referred to as mass balance (Envirowise, 2003). This technique records product material inflows and balances this with outflows on the basis that, what comes in, must go out or be stored. So, if 100kg of materials have been bought and only 80kg of materials have been produced, for example, then the 20kg difference must be accounted for in some way. It may be, for example, that 10% of it has been sold as scrap and 5% of it is waste and 5% is stored. By accounting for outputs in this way, both in terms of physical quantities and in monetary terms too, businesses are forced to focus on environmental costs. Materials measured are in physical units and include energy and water.

b) Flow cost accounting

Flow cost accounting is a tool of a new management accounting approach - flow management. It aims to '...organise production end-to-end in terms of

flows of materials and information -all structured in an efficient, objective-oriented manner' (UNDSD, 2003). It is more than a simple assessment of environmental costs, because it is focused on assessment of total costs of production.

This technique uses both material flows and the organisational structure to calculate costs. It makes material flows transparent by looking at the physical quantities involved, their costs and their value. It divides the material flows into three categories: material, system and delivery and disposal. The values and costs of each of these three flows are then calculated. The aim of flow cost accounting is to reduce the quantity of materials which, as well as having a positive effect on the environment, should have a positive effect on a business' total costs in the long run.

At the end of the process, the material flows can be expressed in monetary units. Process flow charts help to trace inputs and outputs especially wasted materials and highlights the details of the processes so that the relevant information can be allocated to main activities.

c) Environmental activity-based accounting

Activity-based costing (ABC) is a cost system that accurately assigns overhead costs to products on the basis of their usage of an activity. It examines activities that are actually relevant to the production of a product and attempts to determine which products are profitable by allocating all internal costs to the cost centres and cost drivers on the basis of the activities that caused the costs.

It also determines which customers are the most valuable, whether processes are value-adding or not and where efforts towards improvement should be made.

ABC applied to environmental costs distinguishes between environment-related costs and environment-driven costs. The environment-related costs are attributed to joint environmental cost centres e.g. sewage plants. The environment driven costs tend to be hidden in the general overheads and do not relate directly to a joint environmental cost centre, e.g. increased depreciation or higher cost of staff. Nevertheless they vary with the amount of throughput. The great thing about ABC is that it finds cost drivers and then allows those to be reviewed to achieve greater efficiency.

The idea is that producing products creates demand for the activities and activities cause costs so these activities should therefore form the basis for the cost allocation. Some types of allocation methods are: volume of emissions or waste, the relative costs of treating different kinds of emissions, costs of treating contaminated water, etc.

d) Lifecycle costing in environmental accounting

Life cycle costing tracks and accumulates costs and revenues attributable to each product over the entire products life cycle. A product life cycle can be divided into four phases; introduction, growth, maturity and decline. The costs attributable to each phase are determined from the outset from research and design stage through development, market launch, sales and finally to its eventual withdrawal from production or the market. The environmental costs can then be included at each stage from environmentally friendly product designs all the way through to clean up and scrapping costs.

Traditional cost accounting systems tend to dissect product life cycle costs into a series of 12 month periods and do not assess a product's profitability over its entire life taking into account all possible costs.

e) Environmental management as part of total quality management system

Another technique which can be used to properly capture an organisations environmental costs and hence the true financial picture is in the use of Total Quality Management Systems(TQM). TQM is the process of applying a zero defect philosophy to the management of all resources and relationships within an organisation as a means of developing and sustaining a culture of continuous improvement.

An essential component of TQM will be the development of a robust Environmental Management System (EMS). This will involve regular environmental audits of its products and services. An environmental audit provides the platform for organisations to adopt a self-critical and analytical posture as part of their routine organisational management processes.

Key concepts of a TQM organisation are; get it right first time, customer focus and continuous improvement. TQM organisations pursue objectives that may include zero complaints, zero spills, zero pollution, zero waste and zero accidents. Information systems need to be able to support such environmental objectives via the provision of timely feedback - on the

success or otherwise - of the organisational efforts in achieving such objectives. This approach to environmental quality management requires the development of environmental performance measures and indicators that will enable a comprehensive review of environmental performance to be undertaken. The Global Reporting Initiative (GRI) mentioned earlier has a number of environmental KPIs which can be adopted by an organisation.

Organisations should be striving to achieve an integrated environmental strategy as part of their overall business strategy underpinned by the same type of culture that is required for the successful operation of a programme of Total Quality Management (TQM).

CASE STUDY - XEROX

One example of the potential gains from using full costing (sometimes referred to as lifecycle costing, Bennett and James (1998b)) can be seen in the case of Xerox limited.

Xerox limited, a subsidiary of Xerox Corporation, introduced the concept of lifecycle costing for its logistic chain. The core business of Xerox limited is manufacturing photocopiers, which are leased rather than sold. This means the machines are returned to Xerox limited at the end of their lease. Previously, machines were shipped in a range of different types of packaging, which could rarely be re-used by customers to return the old copiers. The customer had to dispose of the original packaging and to provide new packaging to return the machine at the end of its lease, which in turn could not be used to re-ship other machines. This meant Xerox lost the original costs and had to bear the costs of disposal of the packaging.

A new system was invented which used a standard pack (tote). Two types of totes were introduced to suit the entire range of products sold by Xerox. Totes can be used for both new machines delivery and return carcasses. The whole life cycle chain cost analysis showed the considerably lower cost of the tote system, compared to the previously existing system and the supply chain became more visible. The tote system resulted not only in cost savings but also in reduced 'de-pack' times and improved customer relations as no additional packaging costs were borne by the customer (Bennett and James, 1998b).

The lack of clarity over the definition of environmental costs coupled with the lack of knowledge of how to measure it can be seen as contributory factors the poor quality or lack of reporting. The definitions and guidance given by the UNDSO are relatively new and still evolving.

2.4 The Role Of International Professional Accountancy Bodies

International Accountancy bodies and Standard Setters are playing a significant role in ensuring they are influencing the environmental agenda for organisations and their members are at the leading edge of developments in environmental reporting and accounting.

In 2005 IFAC (of which ICAEW is a member) issued its international guidance document on 'environmental management accounting (EMA)'. 'The guidance provides a general framework and set of definitions for management accounting that is comprehensive and as consistent as possible with other existing, widely used environmental accounting frameworks with which EMA must coexist' (IFAC 2005)

There are a number of *IFRS standards* which incorporate an environmental element or have an environmental interpretation e.g. IFRS 6 exploration for and evaluation of Mineral Resources.

ACCA has published a research report outlining an agenda for action on full cost accounting (Bebbington, Gray, Hibbit and Kirk, 2001), which contains a detailed review of the business case for adopting full environmental costing. In 2012 ACCA published a report on reassessing the value of Corporate Reporting which emphasises the need for Environmental Reporting. In 2011 they began examining environmental accounting techniques highlighted by UNDSO (explained earlier) at the technical level. In 2013 they included it in the professional level syllabus. This is due to the growing relevance and significance of environmental reporting in ensuring accountability, transparency and sustainability.

In 2004 *ICAEW* published research on the role of accountants which identified a number of different 'mechanisms' through which the issue of sustainability and environmental accounting could affect business in ways relevant for accountants and financial managers. In 2009 ICAEW published a guide (in collaboration with the Environment Agency) on the implications of environmental issues for external financial reporting. In March 2015 it published a second edition (ICAEW 2004; 2009, 2015). Environmental Reporting and Accounting is examined in various syllabus papers such as audit and corporate reporting, business strategy and management and financial strategy at both certificate and professional level.

These professional bodies are ensuring that they contribute to the debate and equip their members with the tools needed to perform their diverse roles.

As the national accountancy body of Nigeria *ICAN* has not included any substantial elements on the environment in its syllabus for current students to learn tools and techniques for measuring and reporting on the environment. Nor does it train its existing members on environmental disclosure requirements and such. In addition it is unclear how as a professional body it is in anyway influencing the environmental agenda to ensure consistency, accountability, transparency and sustainability of Nigerian organisations to its stakeholders as is the role of the accountant.

2.5 Legal Framework Of What Has Brought About Environmental Accounting Legislation

a) UK environmental legislation a brief history

In the UK environmental legislation evolved in a haphazard way with various different laws trying to control individual environmental problems. After the UK joined the EU in 1972 it began to develop a more consistent approach to tackling the environment using the legislative framework which was adopted from the EU Directive. The UK is quite new to adopting a consistent approach of mandatory disclosures.

Amendments to the UK Companies Act 2006 (Strategic Report and Directors' Report Regulations) which came into force in 2013 requires that companies now need to include new disclosures when they publish their annual reports. The rules require listed companies to make disclosures about human rights, gender diversity and greenhouse gas emissions. Businesses also have to account for the impacts they have on local water quality, plants and animals.

This amendment largely came about as a result of the EU Accounts Modernisation Directive in 2005 which has provided the framework for UK environmental reporting disclosures.

b) Origins and history of environmental accounting laws in Nigeria

Nigeria has a history of environmental problems that date back to the pre independence. They have mainly been around oil exploration. They only caught the media and public attention in 1988 when 4000 tonnes of toxic waste were discovered to have been illegally dumped by Italy in a village in Koko in the old Bendel State. The international and local media pressure pushed the military government to set up Federal Environmental Protection Agency (FEPA) and sign the Basel convention. This was the beginning of Nigeria's environmental policy. In 1989 Nigeria's first national Policy on Environment was produced by FEPA and revised in 1999 during the Nigerian constitution review. The policy emphasised sustainable development, integration of economic activities with environmental improvements to achieve socio-cultural benefit for all citizens. However, implementation of this policy through organisational disclosures is entirely voluntary.

Nigeria has a number of Environmental Acts and Decrees which also date back to pre independence. They have all developed in an uncoordinated way in a similar pattern to that of the UK. Presumably due to the fact that there was no institution set up to coordinate and manage the environmental duties and responsibilities. Some of these Acts/laws include;

1950s - The Noxious Act used to control odour and noise pollution.

1960s - Environmental laws were made by different ministries; e.g. ministry of petroleum oil

pipeline ordinance (1965), oil in navigable water regulation (1968), petroleum drilling and

production regulation (1969).

1970s – The Water Courses Act and Refining Act were enacted to control oil pollution of land and navigable waters and the fishing methods. In 1979

the Nigerian constitution delegated the responsibility of environmental hygiene, cleanliness and refuse management to local states.

1980s - The creation of FEPA (Federal Environment Protection Agency) in 1989

1990s - The local states created their own state owned environmental protection agencies.

2000 - FEPA was upgraded to a full functioning ministry and renamed to Federal Ministry of Environment and has assumed some environmental related duties of other ministries. In addition to a number of laws and policy documents, it has published the National Policy on Environment as the framework for environmental governance in Nigeria.

Some of the key areas of power highlighted in the National Policy on Environment are; environmental impact assessment which is mandatory before any major development project is embarked upon; the powers to issue fines and set taxes of organisations who breach environmental standards for pollution; the power to ensure that resource users pay the full cost of the benefits from natural resources; licensing and registering of all major industrial air and water polluters and monitoring their compliance with laid down standards; imposing penalty taxes, fines, and charges for noncompliance with environmental standards and regulations; promoting tax reliefs and subsidies that encourage investment in pollution abatement.

The Federal Ministry of Environment has signed a number of international conventions on improving the environment including the UN Framework convention on climate change. This includes a voluntary commitment to green house gas emission reduction.

Nigeria's history of environmental laws seems to be developing in the same pattern as the UK of multiple laws for specific problems. In order to properly address the issue of the environment it should be viewed from a bigger picture of a framework under which these laws should be combined to ensure consistency, accountability and to remove duplication and omission. There should be clear targets for the Nation, organisations and individuals to improve their environmental footprint. This has partly been

addressed with the setting up of the Federal Ministry of Environment. However, there is still a long way to go as most of the international conventions which Nigeria has signed up to are entirely voluntary such low level of commitment does not encourage achievement targets or fulfilment of promises. There is also a problem of weak Nigerian Institutions when it comes to enforcement with low prosecution success rates. They lack the basic infrastructure and ability to enforce the fines and levies imposed on the offending organisations and it has been proven that the tax reliefs and subsidies which have been offered to companies have been open to wide scale abuse. According to a Reuters report in 2014 the CBN Governor alerted the Nigerian nation that \$20 billion was owed by NNPC to the government. This money still remains unaccounted for and there has been a forensic audit by PWC but there is no clear explanation or enforcement procedure currently in place to recover it.

2.6 Types Of Disclosures And Motivations For Disclosure In Practice

Environmental disclosures in corporate reports has received growing attention in recent years as part of sustainable development agenda since the surge of environmental catastrophes in the 1980s and 1990s. The increasing motivation for environmental disclosures in corporate reports are due to a number of things such as; globalisation of the activities of multinational companies, non-governmental organisations (NGOs) and civil society pressure groups, and investor pressures. The media and in particular social media has played a very important part in empowering ordinary citizens to raise international awareness of environmental and social issues going on in their local areas.

A survey report carried out by James Odi (2012) into the reasons why Nigerian companies make disclosures of their social and environmental activities. His findings showed that the main reason for such disclosures was to comply with social and environmental standards and other government policies. The second most important reason was due to public awareness and concerns. The other top reason was to enhance the organisation's image and reputation.

In Nigeria only 49% of shareholders consider environmental information to be material to their decision making whereas in New Zealand this figure is 72% (Deegan & Rankin, 1997). In the UK this figure is around 68%.

The report found that whilst these are the motivations for companies to make the environmental disclosures the groups who influence the actual content of the disclosures is very different. The survey showed that the Board of Directors and the managing director had the most influence over the decision to disclose and the extent and content of the disclosure at 62%. The chairman of the board is the next influential person followed by institutional investors. The least influential groups as to report content are the local community and local NGOs.

Due to increasing pressures from the public and particularly the international community, Nigerian organisations are communicating social and environmental issues in their annual reports as self-congratulatory claims and to influence the public perception of the company's image and reputation. Most of this type of information is contained in the director's report or chairman's statement.

The type of information that is considered to be environmentally-related by an organisation can vary widely depending on several factors. The most important of these is the company's main corporate social responsibility related objectives, including how far these derive from external stakeholder pressures and therefore drive a need to generate information to be reported externally, as opposed to an intrinsic motive to manage sustainability performance as part of overall business strategy for reducing its environmental footprint, profitability improvement and shareholder value.

3.0 RESEARCH METHODOLOGY

To analyse the extent of corporate environmental disclosure practice in Nigeria this paper adopted a number of research methods. The latest annual reports of the top 10 Nigerian listed companies were reviewed for their environmental disclosures content. A comparative analysis was done

in two ways a) with its previous 5 years annual reports; b) with the annual reports of top 10 UK listed companies in similar industries to the Nigerian companies. The content analysis method of data analysis was adopted due to the fact that it is the most commonly used method of measuring a company's social environmental disclosure in annual reports (Milne and Adler, 1999). The top 10 listed companies were taken as a sample because they represent a cross section of industries which account for over 60% of the major environmental issues in Nigeria today. The industries include oil and gas, manufacturing cement, construction, transportation, telecommunications, food and beverages and banking. Interviews with 10 Nigerian chartered accountants within Nigerian companies were conducted to establish the extent of their knowledge, awareness and application of environmental accounting and reporting. Interviews were also conducted with chartered accountants in the UK companies to make a comparative analysis of their knowledge, awareness and application of environmental accounting and reporting.

4.0 FINDINGS AND CONCLUSION

From all the Nigerian companies annual reports the following findings occurred;

Most 80% now have some form of corporate, social or environmental information disclosed in their annual reports compared to 5 years ago.

Nigerian companies are making more environmental disclosures than they did 5 years ago. Majority are making voluntary disclosures of environmental and social policy statements under the heading of Sustainability Report or Corporate Social Reporting (CSR). Almost all the disclosures were qualitative in nature. There is a huge focus on CSR, community engagement, social footprint and various statements on compliance with local and international laws. There are also a number of mentions achieving an international quality mark (ISO) or an environmental management system (EMS) but there was no mention of what the EMS does or has achieved. The environmental information appears largely on the Chairman's statement, the Directors report and the sustainability or CSR report. It appears to be driven by the senior team being the board of

directors and chief executive office due to the content of the disclosures. The motivations for the disclosures also appear to corroborate with earlier research in that the main influence was the public image and largely tailored to an international perception that they comply with international standards which are far superior to local ones. In addition the self promotion of the numerous community activities and donations given is further evidence of the desire to create a good image for the public. Apart from one company, there was no quality in terms of content demonstrating commitment to environmental issues such as climate control or improving their environmental impact and reducing carbon emissions. There was little or no information on the financial impact of alternative environmentally friendly practices such as switching to renewable sources of energy or other quantifiable goals. There was no mention of meeting any KPIs or targets as discussed in the earlier literature review.

Most of the organisations Board of Directors are not diverse. They were all male and a mixture of foreign nationals and indigenous Nigerians. Board of Directors diversity has been proven in the UK to have a positive impact on the increase in social and environmental practices and disclosures.

UK companies have a more consistent approach to disclosures possibly due to the mandatory requirements for reporting. There is a mixture of quantitative and qualitative disclosures. There is quantitative information on environmental targets to reduce or improve their environmental footprint in everything they do and what they have achieved so far. There are also qualitative details of changes to processes and practices to a more environmentally friendly business model. For instance BP has switched to the lifecycle project costing model to take account of all possible costs of new projects.

Nigerian companies need to do more to demonstrate their commitment to improving their environmental impact via better quality disclosures and linking this information to their financial performance to create better value for all stakeholders.

From the survey of the Nigerian accountants, it was found that they were all aware of environmental accounting but did not fully understand it and do not see it as such a critical issue in Nigeria at present. They were not aware of the techniques which could be used to measure and improve accountability of their organisations environmental impact. As such they are not in a strong position to advise or influence the Board of Directors in this area.

The results of this research suggest that the current poor quality of reports and internal systems that produce reports, indicate that users of the reports must approach the disclosures with caution and cannot yet confidently rely on reports to comprehensively disclose company performance and impact on the environment.

5.0 RECOMMENDATIONS

Based on the findings the study recommended the following

Environmental expenditure should be tracked and charged separately from other expenditures by organisations. This will provide more accountability and transparency on the organisations reporting its impact on the environment.

Appropriate methods of valuing the environmental assets and costs should be adopted using suitably qualified actuaries and other professional environmental valuers.

Accounting bodies should play a greater role in raising the level of awareness and technical knowledge of their members and also in influencing the environmental reporting agenda. This can be done through training and retraining their members and all accounting staff on techniques for calculating and tracking environmental costs and best practice in corporate reporting of environmental issues.

Standard setters and policy makers should work with the Ministry of Environment and consider introducing mandatory disclosures which are consistent and standardised. They should be relevant and standardised based on nationally and internationally agreed goals for climate change.

There should be a balance of qualitative and quantitative disclosures which clearly link to the financial information contained in the report so that it is useful for evaluating the economic consequences resulting from the organisations environmental practices

REFERENCES

- Gray,R, Adams,C.A., & Owen,D 2014, *Accountability and sustainability: Accounting for Society and the Environment*. Pearson
- Enaharo,J.A. 2009. *Design and Bases of Environmental Accounting in Oil and Gas and Manufacturing Sectors in Nigeria*. Published PHD Thesis
- Mehenna and Veronon P.D.2003. *Environmental Accounting: an Essential Component of Business Strategy*.
- Savitz, A.W, Weber, K, 2006. *The Triple Bottom Line: Jossey-Bass*
- Theron,C.2008. *Environmental disclosures under the new Companies Act*
- Odia,J.O.,A survey of shareholders' requirements for corporate social and environmental disclosures in Nigeria,*Journal of Accounting and Management, JAM vol.4, 1(2014)*
- Onyali, C.I., Okafor T.G., Egolum p., An assessment of Environmental Information Disclosure Practices of Selected Nigerian Manufacturing Companies, *International Journal of Finance and Accounting, 3(6): 349-355 (2014)*
- Ejoh, N.O., Orok-Duke,O.E., Sackey, J.A., The Devedlopment of environmental Accounting Disclosure Practices of Manufacturing Companies in Nigeria, *Journal of Economic and Sustainable Development, vol.5, No 12(2014)*
- Uwalomwa, U., Uadiale,O.M., Corporate Social and Environmental Disclosure in Nigeria: A comparative Study of the Building Material and Brewery Industry, *International Journal of Business and Management, vol.6, No.2 (02/2011)*
- Milne, M.J., and Adler, R.W., (1999). Exploring the Reliability of Social and Environmental Disclosures Content Analysis. *Accounting, Auditing and Accountability Journal, 12(2), 237-256*
- Accountancy Futures, Re-assessing the value or corporate reporting, ACCA (2012)
- Bennett,M., Schalteggers,S., Zvezdou, D., Exploring Corporate Practices in Management Accounting for Sustainability, ICAEW (2013)

National Policy on Environment, Federal Ministry of Environment,
www.environment.gov.ng

De Villiers, C., Van Staden, C., Shareholders Corporate Environmental
Disclosure needs, SAJEMS NS 13(2010) No4

IFAC, International Guidance Document: Environmental Management
Accounting, IFAC (7/2005)

**IMPACT OF LEGAL SYSTEM ON INTERNATIONAL
FINANCIAL REPORTING STANDARDS (IFRS) ADOPTION
IN AFRICA – Emeni, F. K. & Iyoha, F. O.**

**Department of Accounting
Faculty of Management Sciences
University of Benin, Benin City
Nigeria**

e-mail: fkemeni@yahoo.ca

Phone: +2348039412305

and

Ph.D

**Department of Accounting
College of Business and Social Sciences
Covenant University, Ota-Lagos
Nigeria**

Impact of Legal System on International Financial Reporting Standards (IFRS) Adoption in Africa

Abstract

Objective: *the primary objective of the paper is to examine the impact of legal system of a country on IFRS adoption in Africa.*

Method: *the cluster sampling and simple random sampling techniques were adopted in this study. From a population of fifty four countries making up the African continent, a sample of forty six countries was selected. Cross-sectional data of countries were collected from World Bank world development indicators data base and United States of America book of facts. The data collected were analyzed using the ordered logistic regression technique.*

Result: *the study show that there is a positive and significant relationship between the Legal System (LGS) in African countries and IFRS adoption.*

Conclusions: *the implication of the result of this study is the need for a policy shift on the part of the International Accounting Standards Board (IASB) towards embracing other legal systems in Africa (e.g. customary and Islamic law) besides the common law legal system in the countries (Europe) offering the IFRS product, so as to enhance not just the partial but full adoption of IFRS in Africa.*

Key words: legal system, IFRS adoption, Africa, culture, population, IAS

Impact of Legal System on International Financial Reporting Standards (IFRS) Adoption in Africa

Introduction

It is suggested that greater benefits can be attained from International Financial Reporting Standards (IFRS) adoption when it is adopted globally (IASPlus, 2010). The benefit derivable from adoption of IFRS include (1) the expected foreign capital inflow to the adopting country and (2) direct physical network effect of the number of adopters of the product on the quality of the product and indirect effect of increasing the quantity of complementary goods in the country with attendant lower prices (Cai & Wong, 2010). Interestingly, some countries are yet to adopt IFRS despite the expected benefits from its adoption.

A study by Simon Fraser University (2011) has reported that only 54% of African countries have adopted IFRS. The existing literature on why countries adopt IFRS focuses on many variables influencing IFRS adoption decisions by countries such as the expected foreign capital inflow to the adopting country, cultural affinity of African countries to the country offering the IFRS product, and synchronization value of network effect on IFRS adoption (Salter & Douppnik, 1992; Jaggi & Low, 2000; Emeni, 2013; Emeni & Urhoghide, 2014).

Study by Emeni (2013) and Emeni & Urhoghide (2014) show that there is no significant relationship between IFRS adoption decision of countries in Africa and cultural affinity to Europe and synchronization value of network effect. Besides studies by Emeni (2013) and Emeni & Urhoghide (2014), several other studies had investigated the association between IFRS adoption decisions by countries and foreign direct investment, international power politics, cultural affinity to Europe and network effects (Ramanna & Sletten, 2009; Farooque, Yarram & Khandaker, 2009; Epstein, 2009; Beneish, Miller & Yohn, 2010; Cai & Wong, 2010 and Chen, Ding & Xu, 2011). However, these studies ignored the legal system of a country which is considered by researchers (Salter & Douppnik, 1992; La Port, Lopez-de-Silanes, Shleifer, & Vishny, 1996; and Jaggi & Low, 2000) as important element in accounting researches in uniform reporting standards.

Countries are usually divided based on whether or not they are common law or code law states (Ding, Hope, Jeanjean & Stolowy, 2007). This formal grouping might influence whether a country will adopt IFRS or

not. Most nations today follow one of two major legal traditions: common law or civil/code law. Common law is generally uncodified. This means that there is no comprehensive compilation of legal rules and statutes. It is largely based on precedent. In contrast civil/code law is codified. Countries with civil law systems have comprehensive, continuously updated legal codes that specify all matters capable of being brought before a court or presented as financial rules/standards.

Accordingly, the current study attempts to explore the association between legal system of a country to IFRS adoption decisions in Africa. Against this background, the study is designed to answer the following question.

What is the relationship between adoption of IFRS and the legal system

of African countries?

Literature Review

This section of the study discusses the meaning of IFRS and provides a review of the literature on IFRS adoption and legal system. It also presents the theoretical underpinnings of this study.

IFRS Adoption

IFRSs are used in many parts of the world, including the European Union, India, Hong Kong, Australia, Malaysia, Pakistan, Russia, Africa, Singapore and Turkey. As of December 2010, more than 123 countries around the world, including all of Europe, currently require or permit IFRS reporting (IASPlus, 2010).

In practice, adoption of IFRS is in stages, ranging from stage 1 to stage 4 (IMF, 2011). At stage 1, an effort to implement IFRs is still being identified by the country. At stage 2, the country requires and approves publicly listed entities and significant public interest entities to prepare their financial statements using applicable IFRS. Significant public interest entities are defined to include (1) government business entities (2) entities that have their equities or debt instruments listed and traded in a public market (3) other organizations, though unquoted, are required by law to file returns with regulatory authorities: examples of these are financial and other credit institutions; and insurance companies. At stage 3, the country

mandates all other public interest entities to adopt IFRS for statutory purposes. Other public interest entities include (1) entities which are of significant public interest because of their nature of business, size or number of employees or their corporate status which require wide range of stakeholders (2) large not for profit entities such as charities (3) pension funds and (4) publicly owned entities and other entities where there is a potentially significant effects on financial stability. At stage 4 of IFRS adoption, Small and Medium-sized Entities (SMEs) mandatorily adopt IFRS. SMEs refer to entities that may not have public accountability and their debt or equity instruments are not traded in a public market.

The IFRS for SMEs is a self – contained set of accounting principles that is based on full IFRS, but that has been simplified for SMEs. The IFRS for SMEs include requirements for the development and application of accounting policies in the absence of specific guidelines on a particular subject. The IFRS for SMEs does not address (1) earnings per share, (2) interim financial reporting, (3) segmental reporting and (4) non-current assets held for sale. These topics are dealt with in full IFRS but are not generally relevant for SMEs (IASPlus, 2010).

According to Ding, Hope, Jeanjean & Stolowy (2007), over the past few decades, the accounting profession has been facing the pressure of globalization and continuously seeking a way to present financial situations using unique accounting procedures which can be understood by the entire business community of the world. As at today, the unique accounting rule which seems to be embraced by most European countries and their colonies seems to be the IFRS. According to Quigley (2007), many believe accounting harmonization is necessary for the globalization of capital markets. However, Daske, Hall, Leuz & Verdi (2008) are of the view that clear empirical evidence of the economic consequences from mandatory adoption of IFRS has been limited. Some African countries have adopted IFRS; prominent amongst which are: Namibia, Mozambique, Mauritius, Southern Africa, Cameroon, Angola, Uganda, Malawi, Tanzania, Zambia, Ghana and Kenya (Mwaura & Nyaboga, 2009). The extent to which IFRS has been adopted in these countries is presented as appendix 3 in this study; taking into cognizance the five (5) geographical locations (regions) in Africa.

Legal System and IFRS/IAS

Legal system can either directly or indirectly influence the adoption of an international standard. A typical example of direct influence is the development of Companies Acts (e.g., Nigerian Companies and Allied Matters Act – CAMA, 2004) or accounting rules (e.g. IFRS), which prescribe general requirements for measurement and disclosure of accounting information. The measurement and disclosure policies can also be influenced through tax laws, especially in code law countries. According to Tysiac (2014), legal issues and cost/benefit concerns are among the obstacles to adoption of international financial reporting standards. In the light of this, the Pension Fund Forum (2014) in the United States of America called for a full review of the process of setting accounting standards. And countries will adopt IFRS more if the setting of IFRS takes into cognizance existent legal system in would be adopting countries jurisdiction.

The legal system also influences financial disclosures indirectly through legal protection rights provided to investors and creditors, which have been examined by La Porta *et al.* (1996). Porta *et al.* (1996:32) argued that “when investors have relatively few legal rights, then managers can be induced to return the money to these investors if one, or a very small number of investors own the majority of shares.” On the other hand, a strong legal protection provided to investors would encourage small investors to enter the stock market, and consequently, there will be a wider dispersion of ownership in these countries. Their analysis reveals that relatively speaking, common law countries protect investors the most, and French civil law countries protect them the least; German civil law countries are in the middle, though probably closer to the civil law group.

La Porta *et al.* (1996) empirical findings support their argument that strong legal protection provided to investors by common law countries has resulted in a greater dispersion of corporate ownership in these countries. Additionally, they conclude that the common law countries also offer better legal protection to creditors. They argue that with better protection for creditors, firms in common law countries have better borrowing capabilities, and thus will be more accepting of International Accounting Standards (IAS).

Given a strong impact of legal system on corporate ownership and adoption of IAS, as evidenced by the La Porta *et al.*'s (1996) findings, the researcher argue that the legal system also has a significant influence on adoption of international accounting standards. This is because investors and debt holders need information to play an important role in financial

reporting. A widely dispersed ownership and a high level of debt financing in common law countries would place heavy demand on firms for detailed financial disclosures. Moreover, the management of firms with a wide dispersion of ownership would also be more inclined to make more financial disclosures to meet information needs of diverse groups of investors. Similarly, firms with high debt financing would disclose more information to enable debt holders to monitor the observance of debt covenants.

Furthermore, Ball, Kothari & Robin (1998) argue that information asymmetry in common law countries is likely to be resolved by timely public disclosures compared to code law countries where asymmetry is likely to be resolved by private communication between managers and agents of suppliers of labour and capital. In code law countries, firms tend to be conducted by a small number of agents and there is close relationship between agents and principals, which does not encourage disclosure of public information. Therefore, code law countries are less likely to bother about adopting IFRS.

The findings of prior accounting studies also provide evidence to support the impact of legal systems on the development of accounting systems and accounting standards in different countries. Meek & Saudagaran (1990), who examined the legislative process for formulation of accounting standards, argued that different legal systems have different types of impact on adoption of accounting standards. They argued that in code law countries, the laws stipulate minimum requirements, and accounting standards tend to be highly prescriptive and procedural. In common law countries, on the other hand, the law establishes limits and professional judgement is required within these limits.

Salter & Douplik (1992) examined the impact of legal systems on the development of accounting rules in different countries, and they hypothesized that the differences in the legal systems of different countries would explain the differences in the development of accounting rules. Their results indicated that the legal system was a significant predictor of accounting clusters. That is, the legal system of a country significantly impacts the adoption of a uniform international accounting standard like IFRS.

Likewise, Jaggi & Low (2000) examine the impact of legal system on financial disclosures by firms from different countries. The findings show that the legal system of a country plays an important role in financial disclosure and invariable decision to adopt an IAS like IFRS. A

comparatively higher level of legal protection rights provided to investors and debt-holders in common law countries, as documented by La Porta *et al.* (1996), results in a broad-based corporate ownership and high level of debt financing. These corporate characteristics are expected to trigger higher information demand from the financial statement users, which is likely to be matched with demand for a more internationally recognized accounting standard like IFRS. However, the results from Salter & Douppnik (1992) and Jaggi & Low (2000) should be viewed with caution because their sample selection is not robust and representative of the population. Salter & Douppnik (1992) covered only twenty-nine (29) countries in Europe, while Jaggi & Low (2000) covered just six (6) countries in the whole of Europe, Asia and U.S.A. In the light of the above submissions, the assumption in this study is:

H₀: The legal system of African countries has no positive and significant relationship with adoption of IFRS.

Theoretical Framework

This study draws on the theory of reasoned action to ascertain the relationship between IFRS adoption decision of countries in Africa and their legal system. The theory of reasoned action (Ajzen, 1991) posits that accessible behavioural beliefs influence attitude toward behaviour in a given population and accessible normative beliefs influence subjective norm (Ajzen, 2002). Research across behaviours like cross-country study generally found strong support for the theory of reasoned action (Sheppard, Hartwick, & Warshaw, 1988). The theory of reasoned action, which is concerned with determinants of consciously intended behaviours of persons in a given population, has been used in several accounting investigations into the decision to major in accounting (Jackling & Keneley, 2009), the impact of course structure on students' attitudes and behaviours (Shaftel & Shaftel, 2005), the factors that influence the ethical behavioural intentions of public accountants (Buchan, 2005); Gibson & Frakez, 1997) and auditor aggressiveness in client relations (Cohen, 1994).

This theory which was extended to include the theory of planned behaviour (Ajzen, 1991) provides a model that has potential beliefs for

predicting the intention to perform a behaviour based on an individual's attitudinal and normative beliefs in a given population.

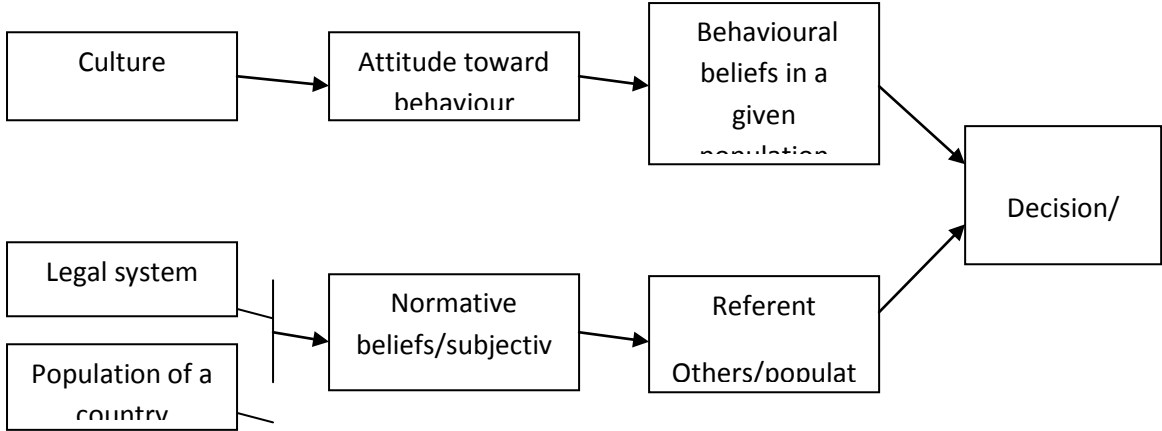

FIGURE: Theory of reasoned action, Source: Ajzen, 1991: 51

Behavioural beliefs are beliefs that results from performing a particular behaviour, while normative beliefs are beliefs about the approval or disapproval of specific or important referents (law and accounting tradition) in a given population. Based on this, the present study focuses on behavioural factors (e.g. cultural affinity, population) that might have influence on behavioural intention; not on actual performance of the behaviour. In this study on adoption of IFRS, if the IASB is perceived as a European institution, countries that are culturally more distant from Europe are likely to be less accepting of IFRS (Ding *et al.*, 2005; Ciesielski, 2007; and Norris, 2007). Thus, using the reasoned action theory, we tested whether cultural closeness and population of a country can explain cross-country variation in IFRS adoption. These two variables (culture and population) were taken as *control variables* in this study.

Under the theory of reasoned action, subjective norm was based on injunctive subjective norm (Sheeran & Orbell, 1999). That is, individual's perception of what important referent (legal system or tradition) expect him or her to do. However, it is argued that it should also include descriptive norm (Sheeran & Orbell, 1999; Ajzen, 2002), that is, the individual's perception of what important referent would normally do (Sheeran & Orbell, 1999). Hence, this study defines subjective norm in terms of descriptive norm, represented by the legal system of a country.

Therefore, using the reasoned action theory, we also tested whether the legal system of a country can explain cross-country variation in IFRS adoption.

Research Method

The research method in this study is an adaptation of Emeni & Urhogide (2014) methodology in a study on “network effects in African countries adoption of IFRS”. The survey research design was adopted in this study. The reason is that the researcher wants to reach to several countries in the African continent and data was collected at a particular point in time; therefore the researcher was involved in a cross-sectional survey research design. The research population comprised the 54 countries in Africa. A survey of the sampled countries with respect to the determinants of IFRS adoption was carried out. The sample size is 46 countries.

The cluster sampling technique was adopted in this study. This was complemented with the simple random sampling technique. The reason for the choice of the cluster sampling technique is that the population of study (the 54 countries making up Africa) is distributed in five clusters/regions. Cluster sampling technique will therefore make for proportional selection of samples such that the number of subjects selected from each region will represent its share of the entire population. For each country in a given cluster/region to have equal chance of being selected, the simple random sampling technique was then introduced.

The clusters are; West Africa (16 countries), East Africa (16 countries), Middle Africa (9 countries), Southern Africa (6 countries) and North Africa (7 countries). The next step in the sampling was to number the countries in each of the clusters in the adequate range. West Africa was numbered 01 to 16; East Africa 01 to 16; Middle Africa 01 to 9; Southern Africa 01 to 06; and North Africa 01 to 07. After which, a computer package (Excel) was programmed to select 46 random numbers within the specified ranges in proportion to the cluster’s share of the total population. The numbers thus generated were used to choose the countries included in the study sample.

IFRS adoption is defined in this study as the decision a country has taken either to adopt IFRS or not (see Ramanna & Sletten, 2009). To measure or arrive at the score for decision on IFRS adoption by an African

country, in this study we computed the total of the stages of adoption (see appendix 1) of the IFRS product for each country that has decided to adopt IFRS. If a country is yet to adopt IFRS as at the date of this study, it was scored zero (Ding *et al.*, 2007). This is because non-adoption of IFRS is a *decision* on IFRS adoption or non adoption (Ramanna & Sletten, 2009). LEGAL SYSTEM is defined as the legal tradition of a country which may be common law or code/civil law tradition (see appendix 1). To measure legal system - it was taken as a dummy variable; coded one if the country has a common law tradition like the country offering the IFRS product and zero otherwise (La Porta *et al.*, 2008).

Derived Model

As earlier stated, when testing the relationship between IFRS adoption decisions and institutional variables, it was done from the perspective of the theory of reasoned action. The theory of reasoned action states that, accessible behavioural beliefs (e.g. culture in a given population) influence attitude towards behaviour and accessible normative beliefs (e.g. legal system) influence subjective norm (Ajzen, 1991). This submission indicates that there are consciously intended behaviours guided by collective programming of the mind (Hofstede, 1980) and rules/norms laid down by regulatory authorities, for example, the population of a people represented by their government or professional accounting bodies. Thus, applying the reasoned action theory, we have the equation below:

$$ADP = f (LGS, CUL, POP) \quad - \quad - \quad - \quad - \quad (1)$$

Where:

LGS = legal system in a country

CUL = cultural affinity to Europe

POP = a country's population

The two variables above (cultural affinity and population) are the control variables.

Model Specification

Based on a study by Emeni & Urhoghide (2014) and assuming a linear relationship, we can write the above equation (1) in an explicit functional form as:

$$Y = \beta_0 + \beta_1 X_1 + \dots + \beta_n X_n \quad \dots \dots \dots (2)$$

Where $\beta_0; \beta_1; \dots \beta_n$ are parameters to be estimated

Y = the dependent variable (IFRS adoption decision)

X_1, X_n = independent variables

X_1 = legal system

X_2 = cultural affinity

X_3 = population

In this case, our 'n' is 3

Thus equation (1) and (2) becomes:

$$ADP = \beta_0 + \beta_1 LGS + \beta_2 CUL + \beta_3 POP + U \quad \dots \dots \dots (3)$$

Where $\beta_0, \beta_1, \beta_2$ and β_3 are parameters to be estimated. The apriori expectation is that;

$$\beta_1 > 0, \beta_2 > 0 \text{ and } \beta_3 > 0$$

Note that 'U' is the error term and β_0 is the constant term.

Results and Discussions

This section discusses the ordered logistic regression results on the impact of

legal system on international financial reporting standards adoption in Africa. The result obtained from the analysis was used to test the hypothesis of the study.

Regression Result

Dependent Variable: ADP

Method: ML – Ordered Logit

Included observations: 46

Number of ordered indicator values: 5

Convergence achieved after 5 iterations

Variable	Coefficient	Std. error	Z-statistic	Probability
LGS	1.428736	0.447587	4.724243	*0.0013
CUL	-0.073530	0.075529	0.382648	0.4465
POP	0.295639	0.353486	0.644283	0.5886
LR statistic	10.886437	Avg. log likelihood		-1.85326
Prob(LR statistic)	0.028657			

Source: E-views 7.0 *significant at 5% level

Stating the above tabular results in equation form we have:

$$ADP = \beta_0 + \beta_1 LGS + \beta_2 CUL + \beta_3 POP + U$$

1.428736 -0.073530 0.295639

In this study each slope coefficient measures the change in the estimated logit for a unit change in the value of the given regressor (holding other regressors constant). Thus, LGS has a positive effect on the logit, that is, if LGS increases by a unit, on average the estimated logit has the likelihood of increasing by about 1.43 units. From the ordered logistic regression result above, Legal System (LGS) appears to be statistically significant at 5% level of significance. Together all the regressors (including the control variables – CUL and POP) have a significant impact on IFRS adoption, as the LR statistic is 10.89, whose p value is about 0.028657, which is very small and which shows that the explanatory variables jointly explain the variation in IFRS adoption. On the whole, the implication of the results shows that the model has an overall good-fit.

Hypothesis Test

The following hypothesis was specified for the study:

H₀: The legal system of African countries has no significant relationship with adoption of IFRS.

H₁: The legal system of African countries has significant relationship with adoption of IFRS.

From the result in the analysis conducted for the null hypothesis above, the relationship between the Legal System (LGS) and IFRS adoption in Africa show that there is the likelihood of a significant relationship between the legal system of an African country and adoption of IFRS at 5% ($p=0.00<0.05$) significance test. This shows that the legal system in an African country affects adoption of IFRS in the continent significantly. The legal system was also found to impact positively on adoption of IFRS which is depicted by the slope coefficient (4.724243). Hence, the null hypothesis (H₀) of no significant relationship between the legal system and IFRS adoption is rejected, while we accept the alternative hypothesis that there is a significant relationship between the legal system of African countries and adoption of IFRS. This result is so because the calculated values of LGS is 4.724243 which is greater than the critical t value of 1.96.

Discussion of Findings

The result in this study show that there is a significant relationship between the legal system of an African country and adoption of IFRS at 5% ($p \leq 0.05$) significance test. The legal system was also found to impact positively on adoption of IFRS which is depicted by the long run slope coefficient (4.724243). This result is in consonance with the position in extant literature (Salter & Douppnik, 1992; La Porta *et al.*, 1996, 2008; and Jaggi & Low, 2000).

According to Salter & Douppnik (1992) the legal system of a country significantly impacts the adoption of a uniform international accounting standard. Likewise, La Porta *et al.* (1996) posits that common law countries offer better legal protection to creditors and as a result, common law countries have better borrowing capabilities and thus will be more accepting of International Accounting Standards (IAS). In their study in 2008, La Porta *et al.* also found that legal system has a significant influence on financial disclosures. In similar circumstances, Jaggi & Low (2000) who examine the impact of legal system on financial disclosures by firms from different countries found that legal system of a country plays an important role in financial disclosure and invariable decision to adopt an international accounting standard.

Conclusion and recommendation

The main objective of this study is to ascertain the impact of legal system on IFRS adoption in Africa. In order to achieve this objective, the theoretical underpinning of this study is the theory of reasoned action. The conclusion in this study was based on the result of the analysis carried out on Africa. Based on the result above, it was ascertained that LGS passed the significance test at 5%. Thus the study failed to accept the null hypothesis.

As earlier pointed out, the result of the relationship between Legal System (LGS) and IFRS adoption was significant and positive. This implies that the legal system among the representative African economies strongly impact on the practice of international financial reporting system. Then to maximize the adoption of international financial reporting standards and to integrate Africa into the global economy properly, the legal institutions in Africa should not relent but continue to take into cognizance the importance of African countries' legal system in IFRS adoption.

Based on the foregoing, the study recommends as follows: since legal system was found to be positive and significantly associated with IFRS adoption in Africa, there is the need on the part of African countries and the IASB, to continue adapting legal systems in Africa to IFRS if adoption of IFRS is to be encouraged. The reason being that, African countries that practice the common law system like most of the European countries offering the IFRS product may be more favourably disposed to adopting the IFRS product unlike their sister countries that are not in this bracket. The point here is that, besides the legal system (common law) in Europe and partly in her colonies like Nigeria, other legal systems in Africa (e.g. customary and Islamic law) should be considered when the International Accounting Standards Board is drawing up the IFRS framework, so as to enhance not just the partial but full adoption of IFRS in Africa.

References

- Ajibade, M. (2011). Financial reporting council (formerly national accounting standard board)" in Essien-Akpan (ed). IFRS: the role of the chartered secretary and administrator, *a paper presented at the 35th conference of institute of chartered secretaries and administrators of Nigeria*, Lagos Sheraton Hotels and Towers, October 26th and 27th.
- Ajzen, I. (1991). The theory of planned behaviour, organizational behaviour and human processes, 50: 179-211.
- Ajzen, I. (2002). Constructing a TpB questionnaire: Conceptual and methodological considerations. <http://people.umass.edu/aizen/pdf.measurement.pdf> [Retrieved 14 January, 2013].
- Ball, R. (2006). International financial reporting standards (IFRS): pros and cons for investors. *Accounting and Business Research*, 5-27.
- Ball, R., S. P. Kothari & A. Robin (1998). The effect of institutional factors on properties of accounting earnings: international evidence. Working paper. University of Rochester.
- Beneish, M.D., B. P. Miller, & T. L. Yohn (2010), IFRS adoption and cross-border investment in equity and debt markets, <http://ssrn.com/abstract=1403451>.
- Buchan, H.F. (2005). Ethical decision making in the public accounting profession: an extension of Ajzen: theory of planned behaviour. *Journal of Business Ethics*, 61 (2), 165-181.
- Cai, F. & H. Wong (2010). The effects of IFRS adoption on global capital market integration. *International business and economic research journal*, 9 (10), 25-34, <http://journals.chiteonline.com/index>.

Chen, C. J. P., Y. Ding & B. Xu (2011), Convergence of accounting standards and foreign direct investment, available at SSRN: <http://ssrn.com/abstract=1703549>.

Ciesielski, J. (2007). Comment letter of the investors technical advisory committee. Norwalk, CT: FASB. <http://www.fasb.org/investorstechnicaladvisorycommitteeitacpdf>.

Cohen, J. (1994). Learning to learn in the accounting principles course: Outcome assessment of an integrative business analysis project. *Journal of Accounting Education*, 12 (4), 359-374.

Daske, H.L., C. Hall, C. Leuz & R. Verdi (2008). Mandatory IFRS reporting around the world: early evidence on the economic consequences. *Journal of Accounting Research* 46: 1085-1142.

Ding, Y., O. Hope, T. Jeanjean & H. Stolowy (2007). Differences between domestic accounting standards and IAS: measurement, determinants and implications. *Journal of Accounting and Public Policy* 26, 1-38.

Ding, Y., T. Jeanjean, & H. Stolowy (2005). Why do national GAAP differ from IAS? The role of culture. *The International Journal of Accounting* 40, 325-350.

Emeni, F.K. (2013). International financial reporting standards adoption in Africa: Does cultural affinity to Europe play a part? *Nirma University Journal of Business and Management Studies*, 8(1&2), 3-16.

Emeni, F.K. & Urhoghide, R. (2014). Network effects in African countries' adoption of international financial reporting standards. *ICAN Journal of Accounting & Finance*, 3(1), 15-26.

Epstein, B.J. (2009). The economic effects of IFRS adoption. *The CPA Journal*, 26-31. <http://www.ifrsaccountant.com.pdf>.

Farooque, O.A., S. R. Yarram, & S. Khandaker (2009), International evidence on governance and foreign direct investment interactions, Singapore economic review conference, 06-08 August 2009.

Gibson, A.M. & A.H. Frakez (1997). A study of critical issue and decision making in accounting. *Journal of Business Ethics*, 16 (2): 161-171.

IASPlus (2010). Country uses IFRSs. IASPlus: <http://www.iasplus.com/country/useias.htm#>.

International Monetary Fund, African Department (2011). *IMF Country Report* No. 11/72. <http://www.imf.org/external/pubs/ft/scr/2011/cr1172.pdf>

Jackling, B. & M. Keneley (2009). Influences on the supply of accounting graduates in Australia: A focus on international students. *Accounting and Finance*, 49, 141-159.

Jaggi, B. & P.Y. Low (2000). Impact of culture, market forces, and legal system on financial disclosures. *The international journal of accounting*, 35, No. 4, 495-519.

- La Porta, R., F. Lopez-de-Silanes, A. Shleifer, & R. Vishny (1996). Law and finance. NBER working paper 5361, *Journal of Political Economy*, 106, 89-123.
- Meek, S. & S. Saudagaran (1990). A survey of research on financial reporting in a transnational context. *Journal of accounting literature*, 9: 145-182.
- Mwaura, F. & B. Nyaboga (2009). International financial accounting standards and the continent of Africa. *International Business and Economics Research Journal* 8, 33 – 46.
- Nigeria companies and allied matters act, 2004.
- Norris, F. (2007) A plan to let S.E.C accept foreign rules is opposed. *New York Times*, September 25.
- Pension Fund Forum (2014). Legal problems with international financial reporting standards, www.lapfforum.org. Assessed 25th February, 2015.
- Quigley, J. (2007). Deloitte & Touche world meeting, Berlin, Germany.
- Ramanna, K. & E. Sletten (2009). Why do countries adopt IFRS? *Working Paper*, Harvard business school.
- Salter, S. B., & T. S. Douppnik (1992), The relationship between legal systems and accounting practices: A classification exercise. *Advances in International Accounting*, 5, 3–22.

- Shaftel, J. & T.L. Shaftel (2005). The influence of effective teaching in accounting on student attitudes, behaviour, and performance. *Issues in Accounting Education*, 231-246.
- Sheeran, P. & S. Orbell (1999). Implementation intentions and repeated behaviour: Augmenting the predictive validity of the theory of planned behaviour. *European Journal of Social Psychology*, 29, 349-369.
- Sheppard, B. H., J. Hartwick, & P. R. Warshaw (1988). The theory of reasoned action: a meta-analysis of past research with recommendations for modifications and future research. *Journal of consumer research*, 15 (3), 325-343.
- Simon Fraser University (2011). Adopt IFRS. Faculty of business administration, Canada. <http://www.adoptifrs.org>
- Tysiac, K. (2014). SEC will seek comments on new possibility for voluntary IFRS adoption. ktysiac@aicpa.org. Assessed 28th December, 2014.

APPENDICES

APPENDIX 1

Operationalisation of Variable

S/N	Variable	Operational definition	Constituting variables	Measurement	Source
1	Adoption	This is the decision on the part of a country to start using the IFRS idea or not to use it whether in full or in phases.	1. International Financial Reporting Standards (IFRS). 2. IFRS adoption decision.	To arrive at the 'adoption score', we computed the total of the stages of adoption of the IFRS product for each African country sampled and zero otherwise (see appendix 3)	Ding <i>et al.</i> (2007)
2	Legal system	Is the legal tradition of a country.	1. Common law 2. Code law	Legal system is a dummy variable, coded one if the country has a common law tradition and zero otherwise.	La Porta <i>et al.</i> (1996, 2008).
3	Cultural affinity	This is cultural sensitivity to the culture offering the IFRS product.	1. Colonial link 2. Sensitivity	It was taken as years since independence from European Union country.	Ramanna & Sletten (2009)
4	Populatio	This is the	Census	It was taken as	Emeni

	n	number of persons living in a given country	figure	population as at last census.	(2013)
--	---	---	--------	-------------------------------	--------

APPENDIX 2

SAMPLED COUNTRIES AND THEIR LEGAL SYSTEM

S / N	List of Countrie s in Africa	IFRS Adoption Status	LEGAL SYSTEM
West Africa			
1	Benin	Not Permitted	Civil law system modeled largely on the French system and customary law
2	Burkina Faso	Not Permitted	Civil law based on the French model and customary law
3	Cape Verde	Not Permitted	Civil law system of Portugal
4	Cote d'Ivoire	Not Permitted	Civil law system
5	Gambia (The)	2009	Mixed legal system of English common law, Islamic law and Customary law
6	Ghana	2007	Mixed system of English common and customary law
7	Liberia	Not Permitted	Mixed legal system of common law(based on Anglo-American law) and customary law
8	Mali	2010	Civil law system based on the French civil law model and influenced by customary law; judicial review of legislative act in Constitutional court
9	Nigeria	2012	Mixed legal system of English common law, Islamic law (in 12 northern states), and

			traditional law
1 0	Senegal	Not Permitted	Civil law system based on French law; judicial review of legislative act in Constitutional court
1 1	Sierra Leone	2006	Mixed legal system of English common law and customary law
1 2	Togo	Not Permitted	Customary law system
East Africa			
1 3	Burundi	2004	Mixed legal system of Belgian civil law and customary law
1 4	Eritrea	Not Permitted	Mixed legal system of civil, customary, and Islamic religious law
1 5	Ethiopia	2010	Civil law system
1 6	Kenya	2005	Mixed legal system of English common law, Islamic law, and customary law; judicial review in High Court
1 7	Madagascar	2005	Civil law system based on the old French civil code and customary law in matters of marriage, family and obligation
1 8	Malawi	2005	Mixed legal system of English common law, Islamic law, and customary law; judicial review of legislative acts in the Supreme Court of Appeal
1 9	Mauritius	2005	Civil legal system based on French civil law with some elements of English common law
2 0	Rwanda	2008	Mixed legal system of civil law, based on German and Belgians models, and customary law; judicial review of legislative acts in the Sepreme Court

21	Seychelles	2009	Mixed legal system of English common law, French civil law, customary law
22	Tanzania	2004	English common law, judicial review of legislative acts limited to matters of interpretation
23	Uganda	2004	Mixed legal system of English common law and customary law
24	Mozambique	2008	Mixed legal system of Portuguese civil law, Islamic law, and customary law
25	Zambia	2005	Mixed legal system of English common law and customary law; judicial review of legislative acts in an ad hoc constitutional council
Middle Africa			
26	Angola	2009	Civil legal system based on Portuguese civil law
27	Cameroon	2009	Mixed legal system of English common law, French civil law, customary law
28	Central African Republic	Not Permitted	Civil law based on the French model
29	Chad	2009	Mixed legal system of civil and customary law
30	Congo (Brazzaville)	Not Permitted	Mixed legal system of French civil law and customary law
31	Congo, Democratic Republic	Not Permitted	Civil legal system based on the Belgian version of French civil

3 2	Equatorial Guinea	Not Permitted	Mixed system of civil and customary law
3 3	Gabon	2009	mixed legal system of French civil law and customary law
3 4	Sao Tome and Principe	Not Permitted	Mixed legal system of civil law based on Portuguese model/customary law
North Africa			
3 5	Algeria	2009	Mixed legal system of French civil law and Islamic law; judicial review of legislative acts in ad hoc Constitutional Council composed of various public officials including several Supreme Court justices
3 6	Egypt	2008	Mixed legal system of French civil law and Islamic law; judicial review of legislative acts in ad hoc Constitutional Council composed of various public officials including several
3 7	Libya	2010	Islamic law
3 8	Morocco	2008	Mixed legal system of civil law based on French law and Islamic law; judicial review of legislative acts by Supreme Court
3 9	Sudan	Not Permitted	Mixed legal system of Islamic law and English common law
4 0	Tunisia	Not Permitted	Mixed legal system of civil law, based on French civil code, and Islamic law; some judicial review of legislative acts in the supreme court in joint
Southern Africa			

4 1	Botswana	2007	Mixed legal system of civil law influenced by the Roman-Dutch model and also customary and
4 2	Lesotho	2007	Mixed legal system of English common law and Roman-Dutch law; judicial review of legislative acts in High Court and Court of Appeal
4 3	Namibia	2005	Mixed legal system of uncodified civil law based on Roman-Dutch law and customary law
4 4	South Africa	2005	Mixed legal system of Roman-Dutch civil law, English common law and customary law
4 5	Swaziland	2008	Mixed legal system of civil, common, and customary law
4 6	Zimbabwe	2005	mixed legal system of English common law, Roman-Dutch civil law, and customary law

APPENDIX 3

EXTENT TO WHICH IFRS HAS BEEN ADOPTED IN AFRICA

WEST AFRICA

Benin

SYSCOA was created in Benin to ensure compliance with IAS (World Bank, 2009). To sum up, IFRS is permitted to be used in Benin.

Burkina Faso

Currently Burkina Faso is under the process of adopting IFRS for SMEs and for its companies (World Bank Group, 2010).

Cape Verde

Accounting standard regulators of the Bank of Cape Verde (BCV) has recommended the adoption of IFRS in 2008, but due to many constraints IFRS is still not permitted in Cape Verde (BCV, 2009). BCV is the central bank of Cape Verde (Wikipedia, 2009). Cape Verde is at stage I of adopting IFRS.

Cote D'Ivoire

The CNC-OHADA has been adopted in Cote D'Ivoire (IFAC, 2010). Although CNC is trying to converge OHADA with IFRS, the two types of accounting standards were still quite different until 2010 (IFAC, 2010).

Gambia

Central Bank of the Gambia (CBG) has started adopting IFRS in 2007, but only until 2009 are they making it mandatory. Other businesses in Gambia are still preparing financial statements according to the Companies Act requirements. IFRS is optional for businesses in Gambia (Deloitte, 2010). Gambia is at stage II of adopting IFRS.

Ghana

As of 2007 IFRS is required for all unlisted banks, utilities, brokerage, insurance, government-owned businesses. IFRSs will be required for all other unlisted entities starting 2009 (Deloitte, 2008).

Guinée-Bissau

West Africa Accounting System (SYSCOA) has been implemented by UEMOA members as financial reporting standard since January 1, 1998 (Investir en Zone Franc, 2010). IFRS is not allowed in Guinée-Bissau.

Mali

The BCEAO has made improvements to move financial reporting closer to International Financial Reporting Standards (IFRS) (The World Bank Group, 2009).

Niger

Niger does not permit any of its companies to use IFRS (Mwuara et al. 2008). They are part of Accountancy bodies of West Africa (ABWA). Niger uses their own national general accepted accounting principles (Mwuara et al. 2008).

Nigeria

Public listed entities and significant public interest entities are required to adopt IFRS from January 1, 2012 (World Bank, 2011). Moreover, the other public interest entities will adopt IFRS in 1 January 2013, and the SMEs will adopt it beginning on 1 January, 2014 (World Bank, 2011). In January 1, 2012, Nigeria started its adoption of the International Financial Reporting Standards (IFRS)

Senegal

Until year 2008, Senegal still allowed organizations to generate financial report under its national GAAP (Mwaura, 2008). IFRS is not allowed in Senegal.

Sierra Leone

On April 8 2009, one of the local banks in Sierra Leone - Access Bank Plc, adopted IFRS in the preparation of its financial statements (AllAfrica Global Media 2009). The adoption of the Standards has been applied to the Bank's accounts for the years 2006/7 and 2007/8 and will be the basis for all financial reporting going forward (AllAfrica Global Media 2009).

Togo

Togolese Republic, known as Togo, is currently at the first stage and IFRS is not permitted (Mwaura & Nyaboga, 2008).

EAST AFRICA

Burundi

Accounting standard regulators of the Bank of the Republic of Burundi (BRB) has adopted IFRS in 2004 (BRB, 2006). BRB is the central bank of Burundi (Wikipedia, 2009). Burundi is at stage II of adopting IFRS.

Comoros

The safeguards assessment in 2007 recommended that efforts to implement International Financial Reporting Standards (IFRS) should be intensified (IMF, 2011). In conclusion, there is no evidence showing that Comoros has adopted IFRS. They are currently at the Stage I. No company in the country can use IFRS as the base for preparing its financial reports.

Djibouti

Djibouti is a member of the MENA (Middle Eastern and North African) region. IFRS is not currently permitted in Djibouti, and companies in Djibouti are following the local GAAP (2009).

Ethiopia

Ethiopia has expressed an initiative to integrate Ethiopia's financial statements with international standards and therefore Ethiopia is in Stage II of the IFRS adoption (The Reporter, 2012).

Kenya

IFRS has been legalized for both listed and non-listed companies in the Companies Act in the latest amendment in 2002 (Assessment of the Regulatory and Standard-Setting Framework -Institute of Certified Public Accountants of Kenya, 2005, Section 4). Kenya is in the fourth stage of the adoption process by the above, and this completes the adoption process.

Madagascar

Currently Madagascar is in the stage IV of IFRS adoption. The General Accounting Plan 2005 (GAP 2005) is Madagascar's current accounting standard. Part of GPA 2005 complies with international standards (IAS, 2003) issued and updated by the committee of IASB (World Bank Group, 2008).

Malawi

Domestic listed companies in Malawi are required to use IFRS when preparing their financial statements. The Companies Act established in 1984 does not require companies to apply IFRS and other accounting standards; however, companies must present a fair view in reporting financial statements (The World Bank Group, 2007).

Mauritius

Accounting standards regulators in Mauritius adopted IFRS through two phases (The Stock Exchange of Mauritius, 2006).

Mozambique

In January 2010, the government of Mozambique approved a decree requiring all listed and unlisted large companies to use IFRS (Mahadevan, 2010).

Rwanda

In 2008, the draft Companies Act (Article 412) mandated registered companies to adopt IFRS and ISA (The World Bank Group, 2008). Also, the countries in the ECSAFA regions, including Rwanda, have all agreed to adopt IFRSs and the IFRS for SMEs (IFRS, 2011).

Seychelles

Accounting regulators of the Central Bank of Seychelles (CBS) has successfully adopted IFRS promulgated by the International Accounting Standards Board for the year ended December 31, 2009 (Nyaboga & Mwaura, 2008)

Tanzania

The National Board of Accountants and Auditors (NBAA) has a legal mandate to set accounting and auditing standards in Tanzania. The NBAA adopted wholesale IFRS and IAS as national standards in effect July 1, 2004 (The World Bank Group, 2005).

Uganda

Uganda permits the use of IFRS in their country (Worldbank 2005; Mwaura & Nyaboga 2008) They reached the second adoption stage of permitting IFRS in their country in 1998 (Worldbank 2005).

Zambia

The Zambia Institute of Chartered Accountants (ZICA) permits all corporate entities, including commercial banks and non-bank financial institutions registered and operating in Zambia, to adopt the International Financial Reporting Standards (IFRSs) issued by the International Accounting Standards Board (IASB) for reporting periods beginning on or after 1 January 2005 (Bank of Zambia, 2006).

MIDDLE AFRICA

Angola

Accounting standard regulators in Angola started to adopt IFRS in 2009 (Deloitte & Touche, 2008), but not fully adopted yet (Deloitte & Touche, 2010). Angola is at stage I in adopting the IFRS regulations.

Cameroon

United Bank for Africa has many locations around the globe, including one located in Cameroon (Wikipedia, 2010). All UBA has adopted IFRS in June of 2009 (UBA, 2009). Cameroon is at stage II in adopting IFRS.

Chad

United Bank for Africa (UBA) has many locations around the globe, including one just opened in August 2009 in Chad (Afrique en ligne, 2009). All UBA has fully adopted IFRS in June of 2009 (UBA, 2009). Chad is at stage II in adopting IFRS.

Congo (Brazzaville)

Currently, statutory financial statements in the country must be prepared in accordance with the Organization for the Harmonization of Business Law in Africa (OHADA) accounting principles (PwC, 2009). In conclusion, no company in the Republic of Congo can use IFRS as the base for preparing its financial reports. The country is currently at stage I.

Congo, the DRC

A timetable for convergence of the Congolese accounting system with the IFRS has been prepared within the CPCC in 2011. In conclusion, currently no company in the Republic of Congo can use IFRS as the base for preparing its financial reports. The country is currently at stage I.

Gabon

Accounting regulators of the United Bank for Africa (UBA) Gabon has fully adopted IFRS in June of 2009 (UBA, 2009). UBA is one of the largest banks

in Africa with one of its locations in Gabon ([Wikipedia, 2010](#)). Gabon is at stage II in adopting IFRS.

São Tomé and Príncipe

Since there is no stock exchange in São Tomé and Príncipe, it does not have any financial reporting standard for listed company (Sao Tome and Principe Country Review, 2010).

NORTH AFRICA

Algeria

Currently, the accounting principle used in Algeria is its national GAAP. However, IFRS are also permitted (Amged Abd El Razik, 2009).

Egypt

Currently all listed companies in Egypt are considered as adopting IFRS (Elbannan, 2010; Kholeif, 2008; Farag, 2009).

Morocco

IFRS in Morocco is required by certain companies. In May 2004, the Moroccan Stock Exchange Law was established and this required that all listed companies (except banks and financial institutions) (IAS Plus, 2006). However, since 1 January 2008, credit institutions are required to produce and present their consolidated accounts in accordance with IFRS.

Sudan

For Islamic banks in Sudan, the institutions are following AAOIFI (Accounting and Auditing Organization for Islamic Institution) standards. In 2011, IFRS Foundation announced that, Sudan, as one of ECSAFA (Eastern Central and Southern African Federation of Accountants), has agreed to adopt IFRS and IFRS for SMEs (IFRS, 2011). However, there is no specific translation plan published by Sudan Government.

Tunisia

Tunisia does not allow any of their national companies to directly apply IFRS, although some foreign institutions are permitted to apply IFRS or their national GAAP for their financial statements (Besalet & Goma, 2005).

Therefore, we would consider Tunisia to be in the second stage of the adoption process.

SOUTHERN AFRICA

Botswana

In 2007 Botswana announced an official adoption of IFRS, requiring all the companies to prepare their financial reports using IFRS. Botswana Institute of Accountants issued the new Financial Reporting Act, requiring public interest entities to adopt IFRS issued by IASB (BIA, 2010).

Lesotho

Adoption of IFRS is permitted for listed companies in Lesotho (Mwaura & Nyaboga, 2008). However, there is no specific information found for the date of permission or other unlisted companies. There is no specific data for the adoption date (TA editorial, 2008).

Namibia

Namibia plans to harmonize the local GAAP with IFRS. According to The Accountant, IFRS for SMEs was adopted as a statement of Namibian GAAP in March 2010 (The Accountant, 2010). Applicability details regarding the use of IFRS for SMEs can be found

South Africa

IFRS is required for listed companies ("Response to the IFAC part 2", 2006). Southern Africa agreed to adopt IFRS from 2005 (IFRS Foundation, 2011). It was also the first country that requires small and medium-sized entities to fully adopt IFRS as its national accounting standards ("IFRS for SMEs", 2009).

Swaziland

Swaziland is at the second stage of adopting IFRS, in which IFRS is permitted, (IAS Plus, 2009).

Zimbabwe

Zimbabwe, an IFAC member, is a country in which there are many standard accounting practices and procedures in place. In Zimbabwe, both IAS and Zimbabwe accounting standards are implemented. The IAS standards and the Zimbabwe standards are almost synonymous. Therefore compliance with IAS basically means compliance with Zimbabwe-specific accounting practices.

**THE ECONOMICS OF HETEROGENEITY:
INTERDISCIPLINARY CORPORATE BOARDS AND FIRM
PERFORMANCE – Ilaboya, O. J.**

(Ph.D., FCA,)

**Associate Professor of Accounting,
ofuanwhyte@gmail.com, ojwhyte@yahoo.com,
+2348033447409, +2348187963213
(Corresponding Author)**

**Mgbame C.O. (Ph.D)
Chijioke.mgbame@uniben.edu
+2348033460311**

**Department of Accounting, Faculty of Management Sciences,
University of Benin, Benin City, Edo State, Nigeria**

The Economics of Heterogeneity: Interdisciplinary Corporate Boards and Firm

Performance

ABSTRACT

The study investigates the relationship between board members discipline and firm performance against the backdrop of increased emphasis on governance issues in the global corporate environment. The study population consists of the 200 listed companies on the Nigerian Stock Exchange as at 31 December 2013 from which a comprehensive panel data set of 54 firms was scientifically selected. The Panel Least Square Regression procedure is the technique of data analysis. The choice of the technique is premised on its property of increased data point and control for individual heterogeneity. We find a significant positive relationship between support specialists, community influential, business experts and firm performance. The control variable of foreign directors did not support our apriori expectation. Our findings suggest that the interaction between directors' unobservable time-invariant characteristics have significant consequences on firm performance in Nigeria. This study contributes to a small but growing body of knowledge on board members' skill and firm performance by advancing a developing country perspective.

JEL Classification: G34

Keywords: Business experts, community influential, support specialists, resource dependency, and skill diversity.

INTRODUCTION

From casual empiricism, it is expected that experience skills, expertise and unique competencies of directors contribute differently to the workings of the board and priorities that drives the strategies that in turn impact the overall growth and development of the business entity. From the perspective of social capital hypothesis, the homophilic quality of the board confers economic benefit through preferential cooperation treatment amongst directors. These advantages are expected to have positive implications on the performance of the organisation.

Surprisingly, the relationship between directors unobservable, time-invariant characteristics and firm performance, has not enjoyed robust empirical consideration, save for leadership style (Bertrand & Scholar, 2003), reputation (Chennaur & Paeglis, 2005), and death of CEO (Nguyen & Nielson, 2010).

Prior studies have focused on observable characteristics of board size, the proportion of outside directors, CEO duality and board independence. These contributions relegated the impact of unobserved heterogeneity of board of directors on firm performance. Basic grounded or hardcore research in this regard is still in its infancy. This problem may be attributable to the paucity of strong descriptive data set on how the board perceive the impact of their role on the performance of the organisation.

The fundamental objective of this study is to expand this frontier of knowledge by developing a model to capture the nexus between the board of directors' skills and firm performance. The study contributes to a small but growing body of literature on the performance implication of directors' unobservable characteristics. Within the broader scope of directors unobservable characteristics lies the sub-theme of board members skills which is the focus of this contribution.

The paper proceeds as follows: following the introduction, section two provides an overview of the extant empirical literature on board skills and firm performance. Section three focuses on the methods with emphasis on analytical framework and modelling. Section four presents estimation results and discussion. Conclusion forms the basis of section five.

REVIEW OF EMPIRICAL LITERATURE

Firm Performance

Performance within the confines of corporate entities is the extent to which set objectives are realised within a particular time frame. Blocher, Chen and Lin (1999:723) define performance evaluation as the “process by which managers at all levels gain information about the performance of the task within the firm and judge that performance against pre-established criteria as set out in budgets, plans and goals”. There are two measures of performance such as accounting-based measures of performance and the most robust approach of balance scorecard

Accounting based measures of performance such as return on equity, return on assets, profit before and after tax and Tobin Q, have been used severally as measures of firm performance in extant empirical literature on corporate governance and other performance-related studies (Abdullah, 2004; Daily & Dalton,1993 ; Yarmack,1996 and Ilaboya & Obaretin, 2015). For purposes of this study, performance is synonymous with profitability i.e. the rate of profit in relation to the volume of activities. We proxy performance using the log of profit after tax as the dependent variable of the study. The choice of log value is premised on the magnitude of the values of profit after tax compared to the size of the other explanatory variables.

Business Experts

Planning and policy development is part of the responsibilities of company directors. Business experts are responsible for formulating the mission and vision statements that chart the future of the company. Markarian and Parboneti (2005) described business experts as directors who are endowed with experience and knowledge connected to strategic decision making. Business experts are individual in top management positions in both public and private blue chip organisations. Business experts must be seen to possess the requisite expertise which according to Ghoshal (1998) is the key resources of the organisation that enhances productive and economic performance. It describes company directors with innate and learned abilities, expertise and expertise and cognate experience (Castanias & Helfat, 2006).

Markarian and Parbonelti (2007) examined firm complexity and composition of board members using 150 firms from six industries over the period 2003-2005 and found that externally complex firms substitute community

influential for business experts. In the same vein, Ness, Vanik Miesing and Kang (2010) found a positive and significant relationship between business experts on the board and corporate performance. Aldamen, Duncan, Kelly, Menamera and Nagel (2011) found that business experts in audit committee boards are associated with positive firm performance. In a more recent study, Hamid, Ahmad and Embong (2014) discovered that directors with relevant industrial experience (business experts) demonstrated positive and significant relationship with performance.

From extant literature, there appears to be a consensus positive relationship between business experts on corporate boards and firm performance even though Finkelstein and Mooney (2003) are of the view that the positive relationship can only be sustained if the homogeneity of skills does not degenerate to destructive conflicts that may retrogress board processes. According to Mitchel and Hambrick (1999), the absence of skills heterogeneity, which is positively related to performance, may lead to a negative relationship between business experts on the board and the performance of the organisation. Against the above backdrop, the first proposition for this study is thus:

Proposition 1: There is no significant relationship between business experts on the corporate board and firm performance.

Community Influential

Community influential are academics, political, military and religious persons with vast experience and linkages with the external stakeholders of the organisation. The status of community influential bring experience and connections that precipitate into a higher level of corporate performance (Baron,1995).Community influential enhance board awareness on the needs of the host communities and external stakeholders and ensure that their interest are taken care of in board decisions (Selznick,1992). Mallin and Mchelon (2010), found that community influential on the board of corporate organisations enhances social performance. In an earlier study, Ruso and Fouts (1997) found a positive association between pro-environment reputation and return on assets.

Community influential provides relevant non-business oriented perspectives on future actions and strategy and relates extensively with influential groups in the society (baron, 1995; Hillman, Cannella & Harris, 2002). In a more

recent contribution, Gantenbein and Volonte (2011) studied 224 listed companies in the Switzerland Exchange Market and conclude that community influential are more relevant than democratic characteristics in explaining the performance of business organisations. Against this backdrop, our second proposition is thus:

Proposition 11: There is no significant relationship community influential on the board and corporate performance.

Support Specialists

Support specialists according to Galbeath (2011), stimulates the skills and experience relevant to evaluate managerial performance and sustainability. Support specialist possess specialised ability, knowledge and skills in specific disciplines such as law, Engineering, Accounting, Banking, and other allied professional disciplines. Support specialists function in helping the business to ameliorate internal business processes that are relevant to the complex internal environment. This is made possible through knowledge spillover process (Zucker et al, 1999).

Support specialists function in the provision of resources to the organisation in the area of legal services, access to capital and government services. They also advice on highly specialised areas. In his study of 193 Canadian firms from 1996 to 2004, Dunn (2010) shows that support specialist is the human capital characteristics that determine gender diversity of the board of the companies studied. Peterson and Philpot (2013) found an insignificant relationship between support specialist and performance of a sample of US firms.

According to Markarian and Parbonetti (2007), support specialist enhances capacity building in firms that operate complex internal and stable external environment.

In this regard, our third proposition is thus:

Proposition 111: There is no significant relationship between support specialists on the board and corporate performance.

METHODOLOGY

Analytical Framework and Model Specification

The framework for the analysis of board members skills and corporate performance is premised on the Pfeffer and Salanik (1978) theory of

resource dependency. Researches based on the theory of resource dependency tends to link the board as a provider of resources with firm performance even though this research path is relatively sparse (Pfeffer, 1972; Boyd, 1990). The board resources is subsumed in a broader concept of board capital which is classified into two categories of human capital (experience, reputation and expertise) and social or relational capital (inter and intra organisational dependency or influence). Board capital addresses both the monitoring and resource provision function of board members. (Hillman & Dalziel, 2003).

According to Pfeffer and Salanick (1978:163), "when organisations appoint individuals to board, it expects that the individual will come to support the organisation, will concern itself with its problems, will invariably present it to others and will try to aid it." The resource dependency theory posits a direct link between the provision of resources and firm performance. However, the truism of the assertion may be dependent on the heterogeneity of the expertise of the corporate board members. Heterogeneous boards benefit from the cognitive conflicts that results in a more thorough and independent consideration of problem solutions (Forbes & Milliken, 1999). Diversity resulting from interdisciplinary board is an imperative for business development. "Diversity may promote the airing of different perspectives and reduce the probability of complacency and narrow-mindedness in board evaluation of executive proposals" (Kosnik, 1990:138). On the basis of the multidisciplinary nature of corporate boards and relying on resource dependency theory, Basinger and Zarokoochi (1986) categorised board members into business experts, community influential and support specialists.

Business experts possess the relevant human capital which according to Mahapier and Ghosal (1998) is the key resources of the organisation that facilitates productive activities. It is therefore expected that the innate abilities, expertise and experience of business experts may enhance the performance of the organisation. Hence,

$$\text{Performance} = f(\text{Business experts}) \text{ -----}$$

----- (i)

In the same vein, support specialists are believed to benefit from knowledge effect (Zucker et al.1999) that help them provide technical assistance, support and advice to customers and business end users. In this regard, it is

expected that these human capital characteristics will translate into improved corporate performance. Therefore,

$$\text{Performance} = f(\text{Support specialists}) \text{-----}$$

----- (ii)

Community influential must possess the social or relational capital that will enhance the provision of advice and counsel on both inter and intra organisational dependency or relation. Westphal (1999) and (2001) found that boards with community influential provide better advice and counsel that is positively related to firm performance. Therefore,

$$\text{Performance} = f(\text{Community influential}) \text{-----}$$

----- (iii)

Combining equations i, ii, and iii, we have a general functional equation of the form:

$$\text{Performance} = f(\text{Business experts, Support specialists and community influential}) \text{---- (iv)}$$

Integrating the control variable of foreign directorship, equation (iv) is expanded as:

$$\text{Performance} = f(\text{Business experts, Support specialist, community influential, Foreign}) \text{--- (v)}$$

Equation (v) is transformed as:

$$\text{PROFT} = f(\text{BEXPT,SSPEC,COMINF, FRGN})\text{-----}$$

----- (vi)

In econometric form, and considering our panel data approach, equation (vi) is transformed as:

$$\text{PROFT}_{it} = \beta_0 + \beta_1\text{BEXPT}_{it} + \beta_2\text{SSPEC}_{it} + \beta_3\text{COMINF}_{it} + \beta_4\text{FRGN}_{it} + \hat{U}_{it} \text{----}$$

---- (vii)

PROFT = is the log of profit, which serves as a proxy for firm performance;
BEXPT = Business experts; *SSPEC* = Support specialists; *COMINF* =
 Community influential; *FRGN* = Foreign directorship.

$t = 1, 2, \dots, 6; i = 1, 2, \dots, 54; \hat{U} = \text{Error term}$

Aprori expectation; from theory and extant empirical literature, it is presumptively expected that directors capital resources will impact positively on the profit of the organisation. Hence, we expect $B_1, B_2, \dots, B_4 > 0$.

Measurement of Variables.

Performance: The dependent variable of performance was proxy by the log of profit after tax of the selected companies.

Business Experts: Using content analysis of the financial statements of the selected firms, board members were classified as business experts if they are managers or past managers of other companies with specialised business knowledge.

Support Specialists: Board members were classified as support specialist if they possess specialised knowledge in the specific industry area in which the firm operates. This includes experts in law, accounting, insurance, public relation, capital market, and engineering and information technology.

Community Influential: Board members were classified as community influential if they were retired military personnel, politicians, members of non- profit organisations and academics. This group of directors are involved in networking and linkage with the general environment of business.

Foreigners: Directors are classified as foreigners if they are non-Nigerians irrespective of the country of origin. The variable of foreign directorship was selected as control variable for the study.

DATA SOURCE AND ESTIMATION TECHNIQUE

The population of the study is the two hundred firms listed on the Nigerian Exchange Market as at December 2013. A sample of fifty four firms was scientifically selected using the Yammane (1967) approach. The regression variables were sourced through a content analysis of the annual reports and account of the selected firms. The Panel Least Square Regression technique is employed as the estimation technique. The study employed cross-sectional time series data. The choice of the approach is premised on the fact that it observes the behaviour of the entities across time.

ESTIMATION RESULTS AND DISCUSSION

Descriptive Statistics

Table 1: Result of the Descriptive Statistics of the Regression Variables

	BEXPT	SSPEC	COMINF	FRGN	PROFT
Mean	5.240143	2.903226	1.308244	2.129032	8.974474
Median	5.000000	3.000000	1.000000	2.000000	8.945890
Maximum	13.00000	10.00000	6.000000	10.00000	11.00040
Minimum	0.000000	0.000000	0.000000	0.000000	6.411620
Std. Dev.	2.346673	2.090048	1.248727	2.211281	0.890522
Skewness	0.575060	0.644866	0.879011	0.756267	-0.054603
Kurtosis	3.655036	2.965910	3.487206	2.729979	2.306710
Jarque-Bera	20.36522	19.35066	38.68817	27.44282	5.726206
Probability	0.000038	0.000063	0.000000	0.000001	0.057091
Sum	1462.000	810.0000	365.0000	594.0000	2503.878
Sum Sq. Dev.	1530.910	1214.387	433.4910	1359.355	220.4623
Observations	279	279	279	279	279

(Source: Researcher' computation 2015)

The descriptive statistics revealed a preponderance of business experts on the boards of the companies studied. The boards have a maximum of 13 business experts, 10 support specialists, 6 community influential, and 10 foreign directors. The average profit of the sampled firm is #11 billion naira. Except the dependent variable of PROFT, all other variables are positively skewed. The standard deviation reported relatively small values which means the variables are clustered closely around their mean values with less dispersion. The positive values of the kurtosis indicate that the data set have peak value near the mean.

The results of the descriptive statistics revealed large Jarque-Bera values and significant probability statistics that are indicative of the standard normal distribution of the regression variables as shown in the bell-shaped histogram in figure one.

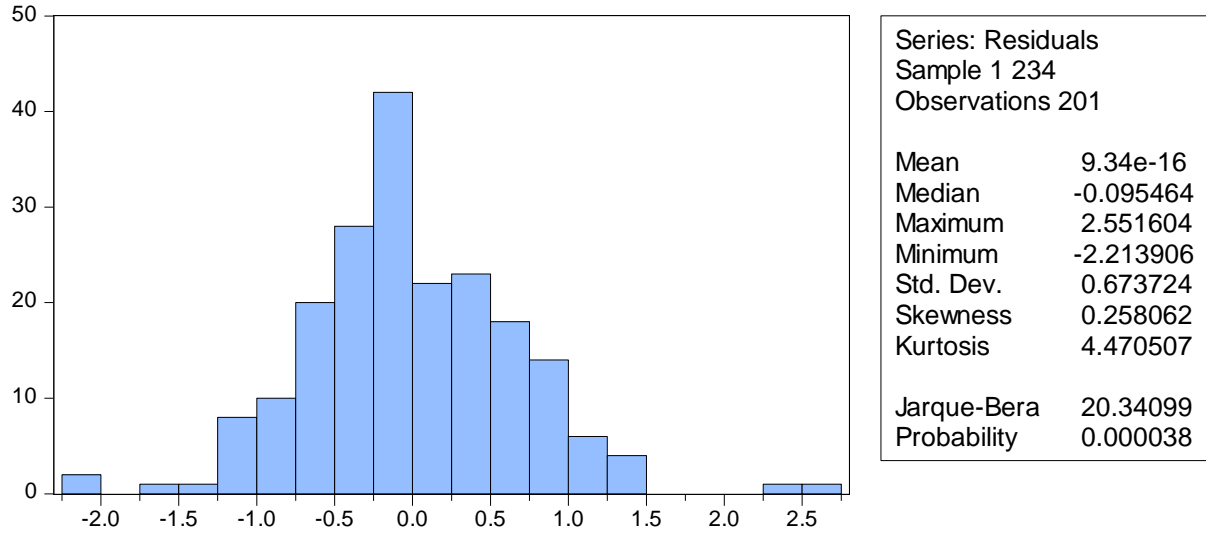

Figure 1: Histogram showing bell-shaped distribution of the regression variables

The bell-shaped histogram of the regression variable is indicative of a standard normal distribution with large Jarque-Bera value of 20.34099 and significant probability value of $(0.000038 < 0.05)$

Correlation Coefficient

Table 2: Results of the test of Correlation coefficient

Covariance Analysis: Ordinary
 Date: 04/14/15 Time: 08:22
 Sample: 1 324
 Included observations: 279
 Balanced sample (listwise missing value deletion)

Correlation	BEXPT	SSPEC	COMINF	FRGN	PROFT
t-Statistic					
Probability					
BEXPT	1.000000				

SSPEC	-0.075186	1.000000			
	-1.254901		-----		
	0.2106		-----		
COMINF	-0.073226	-0.202160	1.000000		
	-1.221996	-3.435543		-----	
	0.2227	0.0007		-----	
FRGN	0.428644	-0.055662	-0.049629	1.000000	
	7.896250	-0.927839	-0.827003		-----
	0.0000	0.3543	0.4089		-----
PROFT	0.378584	0.343138	0.084681	0.265130	1.000000
	6.807595	6.080114	1.414455	4.576424	-----
	0.0000	0.0000	0.1584	0.0000	-----

(Source: Researcher' computation 2015)

The results of the coefficient of correlation revealed a combination of positive and negative correlation. Support specialist (-1.254901), community influential (-0.073226) both reported negative coefficients with the variable of business experts. In the same vein, community influential reported a negative coefficient with support specialist and foreign directors reported a negative coefficient with community influential. The correlation coefficients are relatively low and are not indicative of any problem of multicollinearity.

Variance Inflation Factor

Table 3: Results of the Variance Inflation Factor

Variance Inflation Factors

Date: 04/14/15 Time: 08:33

Sample: 1 234

Included observations: 201

Coefficien Uncenter Centered

Variable	t Variance	ed VIF	VIF
	0.02453	10.6480	
C	6	6	NA
	0.00051	7.05614	1.19528
BEXPT	0	3	7
	0.00062	3.26848	1.03155
SSPEC	1	1	6
	0.00169	2.10882	1.03513
COMINF	3	9	1
	0.00064	2.54010	1.18803
FRGN	4	9	6

Source: Researchers' computation 2015

The results of the variance inflation factor reported relatively small values that are well below the benchmark of 10 points. This is a further confirmation of the absence of the problem of multicollinearity among the regression variables. The variable of business experts reported a centred VIF value of 1.195287, support specialist reported a centred VIF value of 1.031556 while community influential reported a centred VIF value of 1.035131.

Diagnostic Tests

We carried out the relevant regression assumption tests to ascertain the accuracy of the regression model.

Serial Correlation

Table 4: Results of the Serial Correlation Test

Breusch-Godfrey Serial Correlation LM Test:

	58.0543		
F-statistic	7	Prob. F(2,194)	0.0700
	75.2570	Prob. Chi-	
Obs*R-squared	1	Square(2)	0.0600

Source: Researchers' computation 2015

The results of the Breusch-Godfrey test of serial correlation could not sustain the null hypothesis of the presence of serial correlation since the Breusch-Godfrey serial correlation test statistic of (0.0700) and (0.0600) exceeds the critical value of 0.05.

Heteroskedasticity Test

Table 5: Results of the Breusch-Pagan- Godfrey Test of Heteroskedasticity

Heteroskedasticity Test: Breusch-Pagan-Godfrey

	1.96671		
F-statistic	8	Prob. F(4,196)	0.1011
	7.75624	Prob. Chi-	
Obs*R-squared	6	Square(4)	0.1009
Scaled	12.7977	Prob. Chi-	
explained SS	8	Square(4)	0.0123

Source: Researcher' Computation 2015

The results of the Breusch-Pagan-Godfrey test of heteroskedasticity could not sustain the null hypothesis of heteroskedastic residuals since the probability values of (0.1011) and (0.1009) exceeds the critical value of 0.05. The results indicate the presence of homoskedastic residuals.

Test of Normality

Table 6: Results of the Ramsey RESET Test of Normality

Ramsey RESET Test

Equation: UNTITLED

Specification: PROFT C BEXPT SSPEC COMINF FRGN

Omitted Variables: Squares of fitted values

	Value	Df	Probabilit y
	0.8455		
t-statistic	97	195	0.3988
	0.7150		
F-statistic	34	(1, 195)	0.3988
Likelihood ratio	0.7356	1	0.3910

F-test summary:

	Sum of Sq.	Df	Mean Squares
	0.3316		0.33166
Test SSR	62	1	2
	90.780		0.46316
Restricted SSR	79	196	7
	90.449		0.46384
Unrestricted SSR	13	195	2

LR test summary:

	Value	Df
	-	
	205.323	
Restricted LogL	5	196
	-	
	204.955	
Unrestricted LogL	7	195

Source: Researchers' computation 2015.

The results of the Ramsey RESET test show that the variables are normally distributed about their respective mean values. The probability value of (0.3988) and (0.3988) exceeds the 0.05 critical values and further strengthened the bell-shaped histogram reported in figure one.

Results of the Regression Analysis

Table 7: Results of the Panel Least Square Regression Result

Dependent Variable: PROFT

Method: Least Squares

Date: 04/14/15 Time: 08:29

Sample: 1 234

Included observations: 201

Variable	Coefficient	Std. Error	t-Statistic	Prob.
----------	-------------	------------	-------------	-------

	7.30128		
C	6	0.156641	46.61152 0.0000
	0.16495		
BEXPT	0	0.022591	7.301731 0.0000
	0.23493		
SSPEC	5	0.024924	9.426120 0.0000
	0.09507		
COMINF	4	0.041144	2.310794 0.0219
	-		
	0.00063		-
FRGN	8	0.025383	0.025137 0.9800
	0.42319	Mean dependent	8.9401
R-squared	3var		26
Adjusted R-squared	0.41142	S.D. dependent	0.8870
	2var		88
S.E. of regression	0.68056	Akaike info	2.0927
	4criterion		71
Sum squared resid	90.7807	Schwarz	2.1749
	9criterion		43
	-		
Log likelihood	205.323	Hannan-Quinn	2.1260
	5criter.		21
F-statistic	35.9504	Durbin-Watson	0.6828
	5stat		00
Prob(F-statistic)	0.00000		
	0		

Source: Researchers' Computation 2015

The least square regression result reported R-squared value of (0.423193) and adjusted the R-squared value of (0.411422). This means 41% of the cross-sectional variation in the dependent variable of profitability is explained by the independent variables of support specialist, business experts' community influential, and the control variable of foreign directors. The F-statistic of (35.95045) and the associated probability of (0.000000) are both robust and statistically significant and indicate the presence of a linear relationship between the dependent and the independent variables.

The result of the Breusch-Godfrey test of serial correlation, however, nullifies the Durbin-Watson result of the presence of autocorrelation given the DW statistic of (0.682800).

On the basis of individual significance, the t- statistic of (9.426120) of the variable of support specialists is beyond the likelihood of chance and indicates the presence of a significant positive relationship between the variable and the dependent variable of profitability. The result corroborates the findings of Galbreath (2011) who posits that support specialists in corporate boards stimulate the skills and experience relevant to x-ray managerial performance and sustainability. The result is consistent with the position of Markarian and Parbonetti (2007) who conclude that support specialists enhance capacity building in firms that operates in complex internal and the stable external environment.

Expectedly, the variable of business experts has a coefficient of (0.164950) and a robust t- value of (7.301731) which indicates that business experts on the board of corporate organisations, has positive implication on the profitability of the organisation. The result supports Lorsch and MacIver (1989) who posits that the critical advice and counsel of business experts help in formulating corporate strategy and setting long-term priorities, which will no doubt increase managerial performance. The result also supports the views of Ghoshal (1998) who opined that a business expert is the key resources of the organisation that enhances productive and economic resources.

The variable of community influential is positive and statistically significant with a coefficient of (0.095074) and a t-value of (2.310794) and indicates that the presence of community influential on the board enhances the performance of the organisation. The finding is consistent with result of Mallin and Mchelon (2010) who found positive relationship between community influential and social performance, Ruso and Fouts (1997) who found positive association between community influential and pro-environment reputation and Gantenbein and Volonte (2011) who found positive implication of community influential on firm performance.

CONCLUSION

The broad objective of the study is to investigate the dynamics of directors' unobservable characteristics and firm performance. Beyond the robust

empirical consideration of board observable characteristics, there is evidence that interest in the unobservable characteristics of company directors is on the rise.

The increase in corporate malfeasants, distress and outright failure provides the setting for the evaluation of directors' unobservable characteristics. However, the foremost challenge of this direction of research is the lack of adequate information on the company directors with emphasis on age, level of education, religion, and ethnicity. It, therefore, becomes imperative for corporate managers to fine tune their financial reporting regime to capture directors observable and unobservable characteristics.

While this contribution offers an excellent starting point for this line of research, we hope it will sensitise the accounting academic community to a more rigorous scholarly contribution.

References

- Aldamen, H., Duncan, R., Kelly, S., McNamara, R., & Nagel, S. (2012). Audit committee characteristics and firm performance during the global financial crisis. *Accounting and Finance, 52*, 971-1000.
- Baron, D. (1995). Integrated strategy: Market and non-market component. *California Management Review, 37*(2), 47-65.
- Bantel, K., & Jackson, S. (1989). Top management and innovation in banking: Does the innovation of the top team make a difference? *Strategic Management Journal, 10*, 107-124.
- Baysinger, B. D., & Zardkoom, A. (1986). Technology, residual claimants and corporate control. *Journal of Law Economics and Organization, 2*(2), 339-344.
- Bertrand, M., & Scholar, A. (2003). Managing with style: The effect of managers on firm policies. *Quarterly Journal of Economics, 118*, 1169-1208.
- Beckamn, G.M., & Haunsehild, P.R. (2002). Network learning: The effects of partners Heterogeneity of Experience on corporate. *Acquisition Administrative Science Quarterly, 47*, 92-124.
- Boyd, B. (1990). Corporate linkages and organizational environment: A test of the resource dependence model. *Strategic Management Journal, 11* (), 419-430.
- Carpenter, M.A., & Westphal, J.D.(2001). The strategic context of external network ties:

Examining the impact of director appointments on board involvement in strategic decision making. *Academy of Management Journal*, 44, 639-660.

Castanias, R. P., & Helfat, C.E. (2001). The managerial rents model: Theory and empirical analysis. *Journal of Management*, 27(6), 661-678.

Dunn, P. (2010). Breaking the boardroom gender barrier: The human capital of female corporate directors. *J Manage Gov.* doi 10. 1007/s/0997-010-9161-2.

Gabbay, S.M., & Leenders, R.T.A.J. (1999). CSC: The structure of advantage and disadvantage 1-14. In corporate social capital and liability, Leenders, RTAJ and Gabbay, R. (eds.). Boston: Academic Publishers.

Ghabayen, N.A. (2012). Board characteristics and firm performance: Case of Saudi Arabian. *International Journal of Accounting and Financial Reporting*, 2(2), 168-200.

Hamid, A.H., Ahmad, A., & Embong, Z. (2014). Board mechanism influence on Malaysian family firm performance. *International Management Accounting Conference*, 7, 2-3. December Malaysia.

Hillman, A., Cannella, A., & Paretzold, R. (2000). The resource dependence role of corporate directors: Strategic adaptation of board composition in responding to environmental change. *Journal of Management*, 37, 253-256.

Hillman, A.J., & Dalziel, T. (2003). Boards of directors and firm performance: Integrating

agency and resource dependence perspectives. *Academy of Management Review*, 28(3), 383-396.

Joshi, A., & Roh, A. (2009). The role of context in work team diversity research: A Meta-analytical review. *Academy of Management Journal*, 52(3), 544-628.

Kim, Y., & Cannella, A.A. (2008). Towards a social capital theory of board selection corporate governance. *An International Review*, 16 (4), 282-293.

Lynall, M.D., Golden, B.R., & Hillman, A.J. (2003). Board composition from adolescence to maturity: A multitheoretical view. *Academy of Management Review*, 28 (3), 416-431.

Mallin, C.A., & Michelon, G. (2010). Board reputation attributes and corporate social performance: An empirical investigation of the US best corporate citizen.

Michael, J.G., & Hambrick, D.C. (1992). Diversification posture and top management team characteristics. *Academy of Mgt Journal*, 35, 9-37.

Nahapiet, J., & Ghosal, S. (1998). Social capital, intellectual capital and the organisation. *Academy of Management Review*, 23(2), 242-266.

Ness, R., Van, K., Miesing, P., & Rang, J. (2010). Board of directors composition and financial performance in a Sabanes-Oxley world. *Academy of Business and Economics Journal*, 10 (5), 56-74.

Nguyen, B.D., & Nielson, R.M. (2010). The value of independent directors: Evidence from

sudden death. *Journal of Financial Economics*, 98, 550-567.

Pelligrew, A.M. (1992). On studying managerial elites. *Strategic Management Journal*, 13, 163-182.

Peterson, C. A., & Philpot, J. (2013). The finance committee of the board and financial performance: A resource dependence perspective. *Journal of Leadership Accountability and Ethics*, 10(2), 16-33.

Pfeffer, J. (1972). Size and composition of corporate boards of directors: The organisation and its environment. *Administration Science Quarterly*, 17, 218-228.

Ruef, X.A., Aldrides, H.E., & Carter, N.M. (2003). The structure of founding teams: Homophile, strong ties and isolation among US entrepreneurs. *American Sociological Review*, 68, 195-222.

Russo, M.V., & Fouts, P.A. (1997). A resource based perspective on corporate environmental performance and profitability. *Academy of Management Journal*, 40, 534-554.

Setzmick, P. (1992). *The moral commonwealth* Berkeley, CA: University of California press.

Stiles, P., & Taylor, B. (2001). *Boards to work: How directors view their roles and responsibilities*. Oxford: Oxford University Press.

Sunday, K. (2008). Corporate governance and firm performance: The case of Nigerian listed

firms. *European Journal of Economics, Finance and Administrative Sciences*.

Theodorou, E. (1998). The relationship between board structure and firm performance in the UK. *British Accounting Review*, 30, 383-407

Van, E.H., Postma, V.H., & Sterken, E. (2003). Board composition and firm performance in the Netherland. *Eastern Economic Journal*, 29, 41-58.

CONVERGENCE TO INTERNATIONAL FINANCIAL REPORTING STANDARDS (IFRS) AND GLOBAL CONSISTENCY

By

Peace, Ebunoluwa Kolawole

Department of Accounting
Faculty of Social and Management Sciences
Bowen University, Iwo, Osun State

Abstract

This paper examined how convergence to IFRS influences global consistency. In doing this, it assessed whether IFRS is required or permitted for listed companies. The study was conducted mainly on the basis of literature survey and secondary information. Various journals, study reports and research papers were consulted for the purpose of this research. Cross-sectional Research Design was employed as qualitative information regarding 146 countries/jurisdictions convergence status was examined using data obtained from PricewaterhouseCoopers (PWC) on Adoption of IFRS by Country (2014). Content Analysis was used as the basis of analysing the information gotten. Findings revealed that most countries require/permit the use of IFRS in preparing their financial reports. However, for some of them that do not require/permit this, convergence plans are in place. The results showed that countries are generally moving towards having uniform way by which financial statements are to be prepared and reported. However, much effort still needs to be geared towards this as there are some jurisdictions that should be more enlightened as to the convergence process.

KEY WORDS: *Convergence, International Financial Reporting Standards (IFRS), Global Consistency*

1.0 Introduction

There has been a revolution towards having a uniform way of preparing and presenting entities' financial statements universally. Osisioma (2014) identified factors which account for this trend of events as the spate of corporate misadventures, professional abuses and also the litany of corporate woes. As a result of these occurrences, the International Accounting Standards Board (IASB) designed standards intended to reduce information asymmetries amongst countries (Barth, Landsman and Lang, 2008) and users of the financial statements, primarily investors (Haller, Ernstberger and Froschhammer, 2009). The IASB is also committed to developing, in the public interest, a single set of high quality, global accounting standards that require transparent and comparable information in general purpose financial statements (IFRS Handbook, 2011).

International Financial Reporting Standards (IFRS) is seen as uniform sets of reporting standards developed based on high-quality, compatible accounting standards that could be used for both domestic and cross-border financial reporting (Nagash, 2008). IFRS also refers to a series of accounting pronouncements published by the IASB to help preparers of financial statements, throughout the world, produce and present high quality, transparent and comparable financial information (PricewaterhouseCoppers Nigeria, 2014). The term 'International Financial Reporting Standards' includes IFRSs, IASs and Interpretations developed by the Interpretations Committee or the former Standing Interpretations Committee (SIC) (IFRS Handbook, 2011). To achieve this, IASB, formerly known as International Accounting Standards Committee (IASC) collaborates with national accounting standard-setters to bring about convergence in accounting standards around the world. This study is therefore necessary to help to further unfold the convergence process, as this will invariably improve the reliability and comparability of entities' financial reports both locally and internationally.

2.0 Research Objective

This study seeks to determine whether IFRS is required or permitted for listed companies; as a means of assessing the impact convergence to IFRS has on global consistency.

3.0 Concept of IFRS Convergence and Global Consistency

The term 'Global Consistency' refers to the reliability, uniformity, stability and comparability of a thing universally. Considering the impact convergence to IFRS has on global consistency, it implies that there should be a resulting effect of these pronouncements on the preparation, presentation and use of entities' financial statements globally.

According to Siti, Mu'azu and Mohammed (2014),

The idea of accounting standards convergence can be traced back to the 19th

century, when the conception of international standards took essence

during the 1st International Congress of Accountants in 1904 (Ball, 2006).

In the 1950s, in response to integration of economies and improvement

in cross border trade after the Second World War, the idea of convergence

also deepened (Floropoulos, 2006).

The call continued until 1966 when prominent professional accountancy

bodies of the world namely; the Institute of Chartered Accountants of England and Wales, Association of Certified Public Accountants of America,

and Canadian Institute of Chartered Accountants emanated together to

deliberate on the need to have International Accounting Standards. ...

According to them, after extensive discussion, the bodies decided to form

a study group to carry out comparative studies on accounting practices amongst the participating states.

3.1 Analysis of the IFRS jurisdiction profiles

IFRS Foundation (2014) provides an assessment on the progress towards the goal of global accounting standards. The

IFRS Foundation sets out to develop profiles of application of IFRS in individual jurisdictions. Currently, profiles are completed for 138 jurisdictions. This includes all of the G20 jurisdictions plus the other 118 jurisdictions. The following overall observations were made about the information in the profiles describing how IFRS is applied in each of the 138 jurisdictions:

1. **Commitment to a single set of global accounting standards:** Nearly all of the jurisdictions (128 of the 138) have made a public commitment supporting a single set of high quality global accounting standards. Only Albania, Belize, Bermuda, Cayman Islands, Egypt, Macao, Paraguay, Suriname, Switzerland and Vietnam have not.
2. **Commitment to IFRS:** The relevant authority in all but 8 of the 138 jurisdictions (Belize, Bermuda, Cayman Islands, Egypt, Macao, Suriname, Switzerland and Vietnam) have made public commitment to IFRS as the single set of global accounting standards. Even in the absence of a public statement, IFRS are commonly used by publicly accountable entities (listed companies and financial institutions) in Belize, Bermuda, Cayman Islands, and Switzerland.
3. **Adoption of IFRS:** 114 jurisdictions (82 per cent of the profiles) require IFRS for all or most domestic publicly accountable entities (listed companies and financial institutions) in their capital markets. All but 2 of those have already begun using IFRS. Bhutan and Colombia will begin using IFRS in 2021, and 2015 respectively.

Comments on the remaining 24 jurisdictions that have not adopted:

- a. **Twelve jurisdictions permit, rather than require, IFRS:** Bermuda, Cayman Islands, Guatemala, Honduras, India, Japan, Madagascar, Nicaragua, Panama, Paraguay, Suriname, Switzerland;
- b. **Two jurisdictions require IFRS for financial institutions but not listed companies:** Saudi Arabia, Uzbekistan;
- c. **One jurisdiction is in process of adopting IFRS in full:** Thailand;
- d. **One jurisdiction is in process of converging its national standards substantially (but not entirely) with IFRS:** Indonesia; and

- e. **Eight jurisdictions use national or regional standards:** Bolivia, China, Egypt, Guinea-Bissau, Macao, Niger, United States, Vietnam.

The 114 jurisdictions classified as requiring IFRS for all or most domestic publicly accountable entities include the EU Member States to which the IAS 39 'carve-out' applies. The carve-out affects fewer than two dozen banks out of the 8,000 IFRS companies whose securities trade on a regulated market in Europe.

The 114 also include several jurisdictions that have adopted IFRS word for word as their national accounting standards (including Australia, Hong Kong, and New Zealand).

The 114 also include four jurisdictions that have adopted recent, but not the latest, bound volumes of IFRS: Macedonia (2009); Myanmar (2010); Sri Lanka (2011); and Venezuela (2008). Those jurisdictions are working to update their adoption to the current version.

The 138 profiles include all 31 member states of the European Union and the European Economic Area, where IFRS are required for all companies whose securities trade in a regulated market.

- 4. Scope of use of IFRS:** The 114 jurisdictions that require IFRS for all or most domestic publicly accountable entities include 7 that have no stock exchange but that require IFRS for all financial institutions (Afghanistan, Angola, Belize, Brunei, Kosovo, Lesotho, Yemen). Of the 107 jurisdictions that do have stock exchanges, 6 do not require IFRS for listed financial institutions (Argentina, El Salvador, Israel, Mexico, Peru, Uruguay) though they do require IFRS for other listed companies. All of the others require IFRS for all listed companies. Around 60 per cent of the 114 jurisdictions that require IFRS for all or most domestic publicly traded companies also require IFRS for some domestic companies whose securities are not publicly traded, generally financial institutions and large unlisted companies. Over 90 per cent of the 114 jurisdictions that require IFRS for all or most domestic publicly traded companies also require or permit IFRS for all or most non-publicly traded companies.

- 5. Few modifications:** The 138 jurisdictions made very few modifications to IFRS, and the few that were made are generally regarded as temporary steps in the jurisdiction's plans to adopt IFRS. For example, the EU itself describes its IAS 39 'carve-out' as 'temporary', and the 'carve-out' has been applied by fewer than two dozen banks out of the 8,000 IFRS companies whose securities trade on a regulated market in Europe. Several modifications related to IASB agenda projects that are now completed, including loan loss provisioning, use of the equity method to account for subsidiaries in separate company financial statements, and agricultural assets. Jurisdictions have already begun eliminating those modifications. Several other modifications relate to projects currently on the IASB's agenda, including accounting for rate-regulated activities. A few jurisdictions deferred the effective dates of some Standards, particularly IFRSs 10, 11 and 12 and IFRIC 15, though many of those deferrals have now ended.
- 6. Auditor's report:** In 82 jurisdictions, the auditor's report (and/or basis of presentation note) refers to conformity with IFRS. In another 33 jurisdictions the auditor's report refers to conformity with IFRS as adopted by the EU (including the 31 EU/EEA member states plus EU itself plus Albania, a potential accession country). In the 23 remaining jurisdictions the auditor's report refers to conformity with national standards.
- 7. IFRS for SMEs:** 69 of the 138 jurisdictions require or permit the *IFRS for SMEs*, and it is currently under consideration in an additional 15 jurisdictions.

IFRS provide the financial information for capital markets covering over half of the world's GDP:

1. Analysis of IFRS jurisdictions by GDP shows that capital market investors and lenders in jurisdictions with 58% of the world's GDP receive IFRS financial statements. IFRS are also used in some of the remaining economies, for example, by nearly 500 foreign companies whose securities trade in the United States.

While the European Union is the single biggest part of the IFRS usage base, the non-EU/EEA jurisdictions that use IFRS also are a large component of

the IFRS users. All EU/EEA jurisdictions require IFRS for all or most domestic listed companies. The 2012 GDP of those 31 jurisdictions totals \$17.2 trillion US dollars. The combined 2012 GDP of the non-EU/EEA jurisdictions that either require or permit IFRS for all or most domestic listed companies is \$23.8 trillion.

3.2 Analysis of the G20 IFRS Profiles

IFRS Foundation (2014) evaluates progress towards the goal of global accounting standards. The IFRS Foundation is developing profiles of application of IFRS in individual jurisdictions.

The following observations relate to the information in the profiles of the members of the Group of Twenty (informally, the G20), which is the premier forum for international cooperation on the most important issues of the global economic and financial agenda. The G20 brings together finance ministers and central bank governors from the following 19 countries plus the European Union: Argentina, Australia, Brazil, Canada, China, France, Germany, India, Indonesia, Italy, Japan, the Republic of Korea, Mexico, Russia, Saudi Arabia, South Africa, Turkey, the United Kingdom, and the United States of America.

- 1. Commitment to a single set of global accounting standards:** All of the G20 jurisdictions have made a public commitment supporting a single set of high quality global accounting standards.
- 2. Commitment to IFRSs:** The relevant authority in all of the G20 jurisdictions has made a public commitment to IFRSs as the single set of global accounting standards.
- 3. Adoption of IFRSs:** 14 of the G20 jurisdictions have adopted IFRSs for all or most companies in their public capital markets. Of the remaining 6 G20 jurisdictions:
 - a. three permit IFRSs on a limited voluntary basis for domestic and/or foreign issuers (India, Japan, United States);
 - b. one (Saudi Arabia) requires IFRSs on a limited basis (banks and insurance companies only);

c. one (China) has substantially converged its national standards to IFRSs; and

d. one (Indonesia) has adopted national standards that are substantially in line with 2 IASs/IFRSs but has not announced a plan or timetable for full adoption.

4. Scope of use of IFRSs: Of the 14 G20 jurisdictions that have adopted IFRS for all or most publicly traded companies, 11 require IFRSs for all; 2 (Mexico and Argentina) require IFRSs for all other than financial institutions; and 1 (Canada) allows US GAAP for some and has deferred IFRSs for some others. 13 of the 14 G20 jurisdictions that have adopted IFRSs for all or most publicly traded companies also permit IFRSs for all or most non-publicly traded companies.

5. Few modifications: The G20 jurisdictions made very few modifications to IFRSs, and the few that were made are generally regarded as temporary steps in the jurisdiction's plans to adopt IFRSs. There are 5 EU jurisdictions in the G20. While the EU did make an optional 'carve-out' from IAS 39 that the EU itself describes as 'temporary', the 'carve-out' has been applied by fewer than two dozen banks out of the 8,000 IFRS companies whose securities trade on a regulated market in Europe. 2 jurisdictions in the G20 require use of the equity method to account for subsidiaries in separate company financial statements; this issue is now under consideration by the IASB. And the EU deferred the effective dates IFRSs 10, 11 and 12 for one year to 2014, though early application is permitted.

6. Auditor's report: In 18 of the G20 jurisdictions, the auditor's report refers to conformity with IFRSs. In China and Indonesia it refers to conformity with national standards.

a. **IFRS for SMEs:** 7 G20 jurisdictions have either adopted the *IFRS for SMEs* or are actively considering it.

Countries currently considering adopting IFRSs include: United States, Japan, India, Russia, Malaysia and Colombia (Deloitte - IAS Plus, 2014).

4.0 Theoretical Framework

4.1 Economic network theory

Network theory suggests that there are generally two factors to consider in adopting network-dependent products: the intrinsic value of the product and the value of the product's network. This theory predicts that in addition to network benefits (synchronization value), a product with network effects can be adopted due to its direct benefits (autarky value) (Katz and Shapiro, 1985; Liebowitz and Margolis, 1994 as cited in Ramanna and Sletten, 2009).

4.2 Theory of Planned Behaviour (TPB):

TPB posits that a given behaviour is directly influenced by behavioural intentions, which in turn can be predicted by either the attitude toward the behaviour, subjective norm regarding the behaviour or perceived behavioural control. The attitude toward the behaviour is an individual's belief of consequences of performing the behaviour; the subjective norm refers to the perceived social pressures that an individual perceives regarding whether the behaviour should or should not be performed; perceived behaviour control refers to one's perception of the ease or difficulty of performing the behaviour of interest. Numerous studies have demonstrated the applicability of TPB to various content domains (Ajzen, 2001 as cited in Arsen, Duanning, David and William, 2011).

Both theories serve as the basis for this study as the network value/benefit is considered before converging to IFRS and also the belief of the resultant benefits

in adopting these set of standards.

5.0 Methodology

The study was conducted mainly on the basis of literature survey and secondary information. Various journals, study reports and research papers were consulted for the research. Cross-sectional Research Design was employed as qualitative information regarding 146 countries/jurisdictions convergence status was examined using data obtained from PricewaterhouseCoopers (PWC) on Adoption of IFRS by Country (2014). Content Analysis was used as the basis of analysing the information gotten. This was done by sampling a selected set of texts from the population of texts for the analysis. Texts containing information as to whether IFRS is required or permitted for listed companies were chosen. These were displayed in tabular form to show the theme that occurs most and the extent to which global convergence is achieved. (See appendix)

6.0 Results and Discussion

6.1 Data Presentation

Adoption of IFRS by Jurisdictions

	No Jurisdictions	of Percentage (%)
North America	22	15
South America	10	7
Europe	44	30
Asia	35	24
Africa	31	21
Oceania	04	3

7.0 Conclusion

This study contributes to the literature, providing information on Convergence to IFRS and global consistency. The results show that countries are generally moving towards having a uniform way by which financial statements can be prepared and reported. However, more efforts still need to be geared towards this as there are some jurisdictions that should be more enlightened as to the convergence process.

REFERENCES

- Ajzen, I. 2001. Nature and operation of attitudes. *Annual Review of Psychology*, 52, 27-58. In Arsen, D., Duanning, Z., David, G. and William, M. 2011. Critical factors of IFRS adoption in the US: An empirical study. *Journal of Finance and Accountancy*, Eastern Washington University.
- Ball, R. 2006. International Financial Reporting Standards (IFRS): Pros and cons for Investors. *Accounting and Business Research*, 36(1), 5-27. In Siti, Z. S., Mu'azu, S. B. and Mohammed, L. D. 2014. The Effect of Acceptability and Enforceability of International Financial Reporting Standard (IFRS) on Global Accounting Standard Convergence. *Mediterranean Journal of Social Sciences*, Rome-Italy: MCSER Publishing, 5(10).
- Barth, M. E., Landsman, W. R. and Lang, M. H. 2008. International Accounting Standards and Accounting Quality. *Journal of Accounting Research*, 46(3), 467-498.
- Deloitte- IAS Plus. 2014. *Adoption of IFRS by Country*.
- Floropoulos, I. 2006. IFRS First time users: Some empirical evidence from Greek Companies. *Journal of Economics and Business*, Spoudai, 56(3), 39-70. In Siti, Z. S., Mu'azu, S. B. and Mohammed, L. D. 2014. The Effect of Acceptability and Enforceability of International Financial Reporting Standard (IFRS) on Global Accounting Standard Convergence. *Mediterranean Journal of Social Sciences*, Rome-Italy: MCSER Publishing, 5(10).
- Haller, A., Ernstberger, J. and Froschhammer, M. 2009. Implications of the Mandatory

Transition from National GAAP to IFRS — Empirical evidence from Germany. *Advances in Accounting*, 25(2), 226-236.

IFRS Foundation. 2014. *IFRS Application Around the World*.

IFRS Handbook. 2011. *International Financial Reporting Standards*.

Katz, M. L. and Shapiro, C. 1985. Network externalities, competition, and compatibility.

American Economic Review, 75, 424-440. In Ramanna K., and Sletten, E. 2009. Why do countries adopt International Financial Reporting Standards? *Working Paper, Harvard Business School*.

Liebowitz, S. J. and Margolis, S. E. 1994. Network externality: An uncommon tragedy.

Journal of Economic Perspectives, 8, 133-150. In Ramanna K., and Sletten, E. 2009. Why do countries adopt International Financial Reporting Standards? *Working Paper, Harvard Business School*.

Nagash, M. 2008. *The Effects of IFRS Adoption: A Review of the Early Empirical*

Evidence. Available at SSRN: <http://ssrn.com/abstract=1154504>.

Osisioma, B. C. 2014. Overview of IFRS: Costs and Benefits. *Presented at National*

Implementation Workshop on Adoption of IFRS & IPSAS in Nigerian Universities, Idris Abdulkadir Auditorium, NUC Secretariat, Maitama, Abuja.

PricewaterhouseCoppers. 2014. *Adoption of IFRS by Country*. PWC.

PricewaterhouseCoppers Nigeria. 2014. Understanding IFRS. *An interview conducted*

by BusinessDay Newspapers on issues relating to International Financial Reporting Standards (IFRS) and the NASB.

Websites

<http://www.ifrs.org/Use-around-the-world>

www.ifrs.org/...IFRS/Feedback

www.pwc.com

<http://www.nigerianstockexchange.com>

<http://www.financialreportingcouncil.gov.ng>

**APPENDIX
JURISDICTIONS/WHETHER IFRS IS REQUIRED OR PERMITTED FOR
LISTED COMPANIES**

CONTINENT/COUNTRY/JURISDICTION	IS IFRS REQUIRED OR PERMITTED FOR LISTED COMPANIES?	PLANS FOR CONVERGING	FOR
<i>NORTH AMERICA</i>			
<i>Antigua and Barbuda</i>	Required/Permitted	Already Adopted	
<i>Aruba</i>	Not Applicable	Not Applicable (No Local Standard Setting Body)	
<i>Bahamas</i>	Required/Permitted	Not Applicable	
<i>Barbados</i>	Required/Permitted	Not Applicable	
<i>Bermuda</i>	Required/Permitted	Already Adopted	
<i>British Virgin Islands</i>	Not Applicable	Not Applicable (No Local Standard Setting Body)	
<i>Canada</i>	Required/Permitted (with some exemptions)	(with Convergence plans in place)	
<i>Cayman Islands</i>	Required/Permitted	Not Applicable (No Local Standard Setting Body)	
<i>Costa Rica</i>	Required/Permitted	Not Applicable	
<i>Dominican Republic</i>	Required/Permitted (with some exemptions)	(with Convergence plans in place)	
<i>Dutch Caribbean</i>	Required/Permitted	Not Applicable	
<i>(Bonaire, Curacao, Eustatius, Saba, St. Maarten)</i>			

<i>El Salvador</i>	Required/Permitted (with some exemptions)	Convergence plans in place
<i>Guatemala</i>	Not Applicable	Needs to be Approved
<i>(as at April 2013)</i>		
<i>Honduras</i>	Required/Permitted	Convergence plans in place
<i>Jamaica</i>	Required/Permitted	Not Applicable
<i>Mexico</i>	Required/Permitted	Convergence plans in place
<i>Nicaragua</i>	Not Applicable	Already Adopted
<i>Panama</i>	Required/Permitted	Not Applicable
<i>St. Kitts and Nevis</i>	Required/Permitted	Already Adopted
<i>St. Lucia</i>	Not Applicable	Already Adopted
<i>Trinidad and Tobago</i>	Required/Permitted	Not Applicable
<i>United States</i>	Not Required/Permitted	Adapted
<i>SOUTH AMERICA</i>		
<i>Argentina</i>	Required/Permitted (with some exemptions)	Convergence plans in place
<i>Bolivia</i>	Not Required/Permitted	No Specific Date
<i>Brazil</i>	Required/Permitted	Already Adopted
<i>Chile</i>	Required/Permitted	Already Adopted
<i>Colombia</i>	Not Required/Permitted	Convergence plans in place
<i>Ecuador</i>	Required/Permitted	Already Adopted
<i>Paraguay</i>	Required/Permitted	Needs to be Approved
<i>Peru</i>	Required/Permitted	Not Applicable

Uruguay	Required/Permitted (with some exemptions)	Needs to be Approved
Venezuela	Required/Permitted	Convergence plans in place
EUROPE		
Albania	Required/Permitted	Convergence plans in place
Austria	Required/Permitted	Convergence plans in place
Belarus	Required/Permitted	Convergence plans in place
Belgium	Required/Permitted	No Convergence plan
Bosnia and Herzegovina	Required/Permitted	No specific date
Bulgaria	Required/Permitted	Convergence plans in place
Channel Islands	Required/Permitted	Already Adopted
Cyprus	Required/Permitted	Convergence plans in place
Czech Republic	Required/Permitted	No convergence plan
Denmark	Required/Permitted (with some exemptions)	Convergence plan in place
Estonia	Required/Permitted	Convergence plans in place
Finland	Required/Permitted (with some exemptions)	No Convergence plan
France	Required/Permitted	Convergence plans in place
Georgia	Required/Permitted	Not applicable

<i>Germany</i>	Required/Permitted	No Convergence plan
<i>Greece</i>	Required/Permitted	No Convergence plan
<i>Greenland</i>	Required/Permitted (with some exemptions)	Convergence plan in place
<i>Hungary</i>	Required/Permitted	Convergence plan in place
<i>Iceland</i>	Required/Permitted	No formal convergence plan
<i>Ireland</i>	Required/Permitted	Convergence plans in place
<i>Isle of Man</i>	Required/Permitted	Not applicable (No Local Standard Setting Body)
<i>Italy</i>	Required/Permitted	Convergence plans in place
<i>Kosovo</i>	Not Applicable	Not applicable
<i>Latvia</i>	Required/Permitted	Convergence plans in place
<i>Lithuania</i>	Required/Permitted	No convergence plan
<i>Luxembourg</i>	Required/Permitted	Convergence plans in place
<i>Macedonia</i>	Required/Permitted	Convergence plans in place
<i>Malta</i>	Required/Permitted	Not applicable
<i>Moldova</i>	Required/Permitted	Convergence plans in place
<i>Montenegro</i>	Required/Permitted	Not applicable
<i>Netherlands</i>	Required/Permitted	Convergence plans in place

<i>Norway</i>	Required/Permitted	Convergence plans in place
<i>Poland</i>	Required/Permitted	No Convergence plan
<i>Portugal</i>	Required/Permitted	Convergence plans in place
<i>Romania</i>	Required/Permitted	Convergence plans in place
<i>Russian Federation</i>	Required/Permitted	Convergence plans in place
<i>Serbia</i>	Required/Permitted	Not Applicable
<i>Slovak Republic</i>	Required/Permitted (with some exemptions)	No Convergence plan
<i>Slovenia</i>	Required/Permitted	No Convergence plan
<i>Spain</i>	Required/Permitted	Convergence plans in place
<i>Sweden</i>	Required/Permitted	No Convergence plan
<i>Switzerland</i>	Required/Permitted	No Convergence plan
<i>Ukraine</i>	Required/Permitted	Convergence plans in place
<i>United Kingdom</i>	Required/Permitted	Convergence plans in place
<i>ASIA</i>		
<i>Afghanistan</i>	Not applicable	Not applicable
<i>Armenia</i>	Required/Permitted	Convergence plans in place

<i>Azerbaijan</i>	Required/Permitted	Convergence plans in place
<i>Bahrain</i>	Required/Permitted	Not applicable
<i>Cambodia</i>	Required/Permitted	Not applicable
<i>China</i>	Adapted	Adapted
<i>Hong Kong</i>	Required/Permitted	Not applicable
<i>India</i>	Required/Permitted	No Convergence plan
<i>Indonesia</i>	Not Required/Permitted	Not to be Fully Adopted
<i>Israel</i>	Required/Permitted (with some exemptions)	(with Convergence plans in place
<i>Japan</i>	Required/Permitted (with some exemptions)	(with Convergence plans in place
<i>Jordan(as at April 2013)</i>	Required/Permitted	Not applicable
<i>Kazakhstan</i>	Required/Permitted	Convergence to IPSAS
<i>Korea (Republic of Korea)</i>	Required/Permitted	Convergence plans in place
<i>Kuwait</i>	Required/Permitted	Not applicable
<i>Kyrgyz Republic</i>	Required/Permitted	Not applicable
<i>Laos</i>	Required/Permitted	No specific date
<i>Lebanon</i>	Required/Permitted	Not applicable
<i>Macao Special Administrative Region</i>	Not applicable	Convergence plans in place
<i>Malaysia</i>	Adapted	Adapted
<i>Mongolia</i>	Required/Permitted	Already Adopted
<i>Oman</i>	Required/Permitted	Convergence plans in place

<i>Pakistan</i>	Required/Permitted	Convergence plans in place
<i>Philippines</i>	Required/Permitted	Already Adopted
<i>Qatar</i>	Required/Permitted	Not applicable
<i>Saudi Arabia</i>	Required/Permitted (with some exemptions)	Convergence plans in place
<i>Singapore</i>	Required/Permitted (with some exemptions)	Convergence plans in place
<i>Sri Lanka</i>	Required/Permitted	Not applicable
<i>Taiwan</i>	Required/Permitted	Convergence plans in place
<i>Thailand</i>	Not Required/Permitted	Convergence plans in place
<i>Turkey</i>	Required/Permitted	Convergence plans in place
<i>United Arab Emirates (as at April, 2013)</i>	Required/Permitted	Not applicable
<i>Uzbekistan</i>	Required/Permitted (with some exemptions)	No formal Convergence plan
<i>Vietnam</i>	Partially Required/Permitted	Convergence plans in place
<i>West Bank/Gaza</i>	Required/Permitted	No convergence plan
<i>AFRICA</i>		
<i>Algeria (as at April, 2013)</i>	Required/Permitted	Already Adopted
<i>Angola</i>	Not Applicable	No convergence plan
<i>Botswana (as at April, 2013)</i>	Required/Permitted	Not applicable
<i>Cameroon</i>	Not Required/Permitted	No convergence plan

<i>Chad</i>	Not Required/Permitted	No convergence plan
<i>Cote D'Ivoire</i>	Not Required/Permitted	No convergence plan
<i>Democratic Republic of Congo</i>	Not Applicable	Convergence plans in place
<i>Egypt</i>	Not Required/Permitted	Partial convergence
<i>Equatorial Guinea</i>	Not Required/Permitted	No convergence plan
<i>Gabon</i>	Not Required/Permitted	No convergence plan
<i>Ghana</i>	Required/Permitted	Already Adopted
<i>Guinea Conakry</i>	Not Applicable	No Convergence plan
<i>Kenya</i>	Required/Permitted	Not applicable
<i>Libya</i>	Required/Permitted	No convergence plan
<i>Madagascar</i>	Not Applicable	No convergence plan
<i>Malawi (as at April, 2013)</i>	Required/Permitted	Not applicable
<i>Mauritius</i>	Required/Permitted	Not applicable
<i>Morocco</i>	Required/Permitted	No convergence plan
<i>Mozambique (as at April, 2013)</i>	Required/Permitted	Convergence plan in place
<i>Namibia</i>	Required/Permitted	Not applicable
<i>Nigeria</i>	Required/Permitted	Convergence plans in place
<i>Republic of Congo</i>	Not Required/Permitted	No Convergence plan
<i>Rwanda</i>	Required/Permitted (with some exemptions)	Already Adopted
<i>Senegal</i>	Not Required/Permitted	No Convergence plan
<i>South Africa</i>	Required/Permitted	Not applicable

Swaziland	Required/Permitted	Not applicable
Tanzania	Required/Permitted	Not applicable
Tunisia	Not Required/Permitted	Convergence plans in place
Uganda	Required/Permitted	Not applicable
Zambia	Required/Permitted	Already Adopted
Zimbabwe	Required/Permitted	Already Adopted

OCEANIA

Australia	Required/Permitted	Not applicable
New Caledonia	Required/Permitted	Convergence plans in place
New Zealand	Required/Permitted	Convergence plans in place
Papua New Guinea	Required/Permitted	Already Adopted

Source: Adapted from 'Adoption of IFRS by Country' by PricewaterhouseCoppers, 2014

Theme Indicators

Is IFRS Required OR Permitted for Listed Companies?

Required/Permitted: This implies that IFRS is either required or permitted for consolidated and standalone/separate financial statements.

Not Required/Permitted: This implies that IFRS is neither required/permitted OR prohibited for consolidated and standalone/separate financial statements. This is due to the fact that the reporting framework in such jurisdiction is to be adhered to.

Adapted: This implies that the principles of IFRS are being followed or the nation's local GAAP serves as a direct translation of IFRS.

Not Applicable: This refers to the absence of local exchange in such jurisdiction.

Plans for Converging

Convergence plans in place: This means that there are plans already in place for converging to IFRS.

No Convergence plan: This refers to the notion that the local standard setting body has not yet announced the adoption or convergence plan.

Needs to be Adopted/No Specific date: This implies that the adoption of IFRS is awaiting the implementation by the local standard setting body or that no exact time frame has been announced for its adoption/implementation.

Not Applicable: This implies that the jurisdiction concerned has already begun the convergence process or that there is no local exchange to allow for its adoption.

Adapted: This implies that the local standards setting body follows the principles of IFRS without adopting it.

INTERNATIONAL FINANCIAL REPORTING STANDARDS (IFRSs)

IFRS 1	First-time Adoption of International Financial Reporting Standards
IFRS 2	Share-Based Payment
IFRS 3	Business Combinations
IFRS 4	Insurance Contracts
IFRS 5	Non-current Assets Held for Sale and Discontinued Operations
IFRS 6	Exploration for and Evaluation of Mineral Resources
IFRS 7	Financial Instruments: Disclosures
IFRS 8	Operating Segments
IFRS 9	Excluded in IFRS Blue Book (2015)
IFRS 10	Investment Entities
IFRS 11	Joint Arrangements

IFRS 12	Disclosures of Interests in Other Entities
IFRS 13	Fair Value Measurement
IFRS 14	Regulatory Deferral Accounts (Issued January, 2014)
IFRS 15	Revenue from Contracts with Customers (Issued January, 2014)

SOCIAL AND ENVIRONMENTAL ISSUES IN NIGERIA: ARE CORPORATE ENTITIES IN NIGERIA SHOWING CONCERN? -

Mamidu, A. I., Adetula, S. L., & Abu, J. A.

isholaaruna@yahoo.com

^[a] Accounting Department, College of Social and Management Sciences,
Achievers University, Owo, Ondo State, Nigeria

0803-744-3810

ABSTRACT

The study critically looked into the ways in which social and environmental provisions in Nigeria can be improved upon and the body that should be socially responsible. Is it the government or the corporate entities? This paper selected six companies that are quoted in Nigeria Stock Exchange, taking two from each sector, and examined the content and quality of the concerns demonstrated in their 2013 Annual Report and Accounts for Social and environmental issues in Nigeria. Special attention was placed on the similarities or differences among the companies in their social and environmental care. This paper discovered that social and environmental issues in Nigeria had been grossly neglected by the corporate entities. They hardly reported on it in their annual reports. Even where there was report on the social and environmental issues, it is always in the Chairman's speech. The main conclusion of this paper is that corporate social responsibility (CSR) is an integral part of the new business model and that it is increasingly recognized that the role of the business sector is critical. As a part of society, it is in business' interest to contribute to addressing common problems. Strategically speaking, business can only flourish when the communities and ecosystems in which they operate are healthy.

Key Words: corporate, responsibility, communities and grossly neglected.

Word Count: 208

Introduction:

When companies operate within an area or community, it is ethical for such an entity to be socially responsible. Corporate social responsibility (CSR) is a term that means that whatever a company does to give back to the community in which it operates. Sometimes this involves educational scholarship, pro-healthy environmental activities and provision of social activities. There are some companies' activities that pose health hazards to the community. In such communities, it is ethical for such corporate entities to keep the environments healthy by embarking on health free sponsored social programmes.

There are diverse opinions as to whether corporate entities should be socially responsible or not. The Ogoni people and other oil producing areas of Nigerian people had been clamouring in years past that a lot needs to be done by the companies operating in their areas in terms of social responsibilities and environmental health concerned activities. While some of companies in Nigeria are claiming that they are socially and environmentally responsible, many of the communities in which they operate are not enjoying good social amenities and a lot of social menaces face the communities. Hence, it is pertinent at this point to delve into the follow areas:

- Are corporate entities in Nigeria doing enough in their CSR?
- Who should be socially responsible, Government or Corporate Bodies?
- What are the areas to engage in CSR?
- What are the advantages and disadvantages of CSR?

The researcher used four methods to select an adequate sample of articles and books for review:

1. Using the 2013 Financial Statements and Reports of six Nigeria quoted companies – two from each sector.
2. A systematic search of the academic and professional literature on CSR, as well as a keyword search in the library.
3. Library cat log using keywords such as *corporate social responsibility*, *corporate citizenship*, *ethical responsibility* and names of authors were used to bring out facts about the subject matter.
4. A review of bibliographic references from articles found.

The references came from scholarly journal articles, articles from the popular press and books from popular authors.

ORGANISATION OF THE PAPER

This study is divided into nine parts. The first takes care of the Abstract.

Section two spells out the Introduction. Part three of the study enumerated the Objective of the paper. Section four and five treated the Relevance Of The Study and Literature Review respectively. The fifth part takes care of Nigeria Experience on Environmental Reporting. Part six analysed the Errors in Social and Environmental Reporting in Nigeria. Sections seven deals with the Hindrances to CSR Implementation in Nigeria while the eight brought out the Summary Conclusion and Recommendations

THE OBJECTIVE OF STUDY

It must be recognized up front that CSR still creates a degree of confusion and controversy. Is the promotion and implementation of socially and environmentally corporate conduct a function of business or government? Is the implementation of CSR practices a cost or a value-enhancer? Is it just public relations? In past, the problem stems from definitional issues, and a perception in some quarters that CSR is more about philanthropy, rather than “doing business” and responding to shareholder interests. The central argument of this paper is that CSR is an integral part of the new business model. The main objective of the study is to evaluate how the corporate and business entities in Nigeria had been socially responsible in their immediate community.

Other secondary objectives include:

- The challenges the corporate and business entities in Nigeria are facing when trying to be socially responsible.
- The benefits that accrue to both the business entity and the community when efficient social responsibility are put in place.
- To open the eyes of corporate and non corporate entities on the ways to be socially responsible.
- To proffer solutions to some of the problems that may crop up when entities are implementing their social responsibility plan and the cleaning up of the environment.

RELEVANCE /SIGNIFICANCE OF STUDY

The Study will useful to both individuals and the government at large in the following ways:

- Proffering a good ways of solving the unemployment problem in Nigeria if the recommendation of the study is followed.
- Recommending ways of solving the challenges of business entities when trying to implement social and environmental issues.
- Opening the eyes of corporate and non corporate entities to various ways to be socially and environmentally responsible.

Literature Review

Wood, (1991) was of the opinion that corporate social responsibility (CSR) is also called corporate conscience, corporate citizenship, social performance, or sustainable responsible business. Wood, (1991) defined CSR as a form of corporate self-regulation integrated into a business model. He noted that CSR policy functions as a built-in, self-regulating mechanism whereby a business monitors and ensures its active compliance with the spirit of the law, ethical standards, and international norms. There are some models, a firm's implementation of CSR goes beyond compliance and engages in "actions that appear to further some social good, beyond the interests of the firm and that which is required by law. (McWilliams, Abigail; Siegel, Donald, 2001 and McWilliams, Abigail; Siegel, Donald; Wright, Patrick M. March, 2006)." DeGeorge, and Richard, (2010) defined Corporate Social Responsibility (CSR) as a process which aims to embrace responsibility for the company's actions and encourage a positive impact through its activities on the environment, consumers, employees, communities, stakeholders and all other members of the public sphere who may also be considered as stakeholders. Diverge, and Richard, (2010) opined that the term "corporate social responsibility" became popular in the 1960s and has remained a term used indiscriminately by many to cover legal and moral responsibility more narrowly construed. Paul Hohnen, (2012) pointed out as said by Niall Fitzgerald, former CEO and Chairman, Unilever:

"We believe that the leading global companies of 2020 will be those that provide goods and services and reach new customers in ways that address the world's major challenges—including poverty, climate change, resource depletion, globalization, and demographic shifts."

NIGERIA EXPERIENCE ON ENVIRONMENTAL REPORTING

Many corporate bodies had not been socially responsible in Nigeria in the past. It is only in the recent time after the 1999 elections that the big companies especially in banks, Oils & Gas and Communications sectors had significant effects on the economy of the nation when talking of social and environmental responsibility. Despite this fact, most corporate bodies in Nigeria see environmental care as just another way of giving part of the profit they had made in the society back to the environment – they only believed that it is corporate philanthropy.

The Tables below show an excerpt of 2013 Financial Statement and Report from six Nigeria quoted companies in the Nigeria stock Exchange.

The table exemplified the corporate concerns for Social and environmental issues in Nigeria. From the Beverages sector are Cadbury Nigeria Limited and International Breweries; from the Petroleum sector are SEPLAT Oil and Mobil Oil; while from the Banking sector we have First Bank Plc. and ZENITH Bank Plc.

TABLE 1: SAMPLES ON SOCIAL AND ENVIRONMENTAL CARE IN NIGERIA.					
			CORPORATE SOCIAL RESPONSIBILITY REPORTING		
CO Y	NAME	NOT ES	REPORT ON PEOPLE (EMPLOYEE)	REPORT ON PROFIT	REPORT ON PLANET
BEVERAGE	CADBURY NIGERIA LTD	E & F	<ul style="list-style-type: none"> •Employed 2 physically challenged •Value spent on employee not reported 	<ul style="list-style-type: none"> • Profit after Tax = ₦6,023,219,000:00 	<ul style="list-style-type: none"> •Amount spent on the community – N8.4m •Safety week organised yearly •Value spent on environment – Not reported
	INTERNATIONAL BREWERIES	10 & 11	<ul style="list-style-type: none"> •Physically challenged employment – Not reported •Value spent on employee not reported 	<ul style="list-style-type: none"> •Profit after Tax = ₦2,506,490,000:00 	<ul style="list-style-type: none"> •Amount spent on the community – N10.72m •Compliance with US ten principles on environment. •Value spent on environment – Not reported

TABLE 2: SAMPLES ON SOCIAL AND ENVIRONMENTAL CARE IN NIGERIA.

CORPORATE SOCIAL RESPONSIBILITY REPORTING					
CO Y.	NAME	NOT ES	REPORT ON PEOPLE (EMPLOYEE	REPORT ON PROFIT	REPORT ON PLANET
PETROLEUM	SEPLA T OIL	Under Chairman's speech	<ul style="list-style-type: none"> •Physically challenged employment – Not reported •Value spent on employee not reported 	<ul style="list-style-type: none"> •Profit after Tax = \$550,268,000,000 	<ul style="list-style-type: none"> •Health and educational programs •Educational: to 722 students at a cost of 19.3 million •Skills acquisition training. •Donated computers to the University of Benin, Department of Petroleum Engineering. •The Company also initiated a state-wide educational programme. •Value spent on environment – Not reported
	MOBI L OIL NIG. PLC.	10 & 11	<ul style="list-style-type: none"> •Employment opportunities are open to all suitable qualified 	<ul style="list-style-type: none"> •Profit after Tax ₦ 5,123,002,000 	<ul style="list-style-type: none"> •Amount spent on the community – Not reported •Value spent on environment –

			Nigerians irrespective of their place of origin, religion or gender. The same opportunities are opened to qualified physically challenged persons.		Not reported
--	--	--	--	--	--------------

TABLE 3: SAMPLES ON SOCIAL AND ENVIRONMENTAL CARE IN NIGERIA.

CORPORATE SOCIAL RESPONSIBILITY REPORTING					
CO Y	NAME	NOTES	REPORT ON PEOPLE (EMPLOYEE	REPORT ON PROFIT	REPORT ON PLANET
BANKING	FIRST BANK PLC (HOLDINGS)	Under Chairman's speech	<ul style="list-style-type: none"> Physically challenged employment – Not reported Value spent on employee not reported 	<ul style="list-style-type: none"> Profit after Tax ₦ 70,631,000,000 	<ul style="list-style-type: none"> Amount spent on the community – Not reported
	ZENITH BANK	10 & 11	<ul style="list-style-type: none"> The Bank's policy prohibits discrimination against disabled persons in the recruitment, Training and career 	<ul style="list-style-type: none"> ₦110,597,000,000 Profit before tax (continuing and discontinued operations) 	<ul style="list-style-type: none"> Amount spent on the community – ₦ 856m Amount spent on the community – Not reported

			development of its employees. •Male 52% Female 48%		
--	--	--	--	--	--

(SOURCES: FROM THEIR 2013 FINANCIAL STATEMENT AND REPORT)

Tables 1, 2, & 3 above show an excerpt of 2013 Financial Statement and Report from six Nigeria quoted companies in the Nigeria stock Exchange. It clearly indicates the current nonchalant and nothing to write home about of attitude of Nigeria companies towards their social and environmental concerns.

When discussing the issue of social and environmental responsibilities, the three principal things that should be reported on are: the People, Profit and the Planet. Some authors called this '*the triple bottom line reporting*'.

ANALYSIS OF TABLES

- **Beverages Companies: Cadbury Nigeria Limited** reported a profit of ~~₦~~6, 023,219,000:00 after tax. On the employee, two physically challenged persons were reported employed during the year. The sum of ~~₦~~ 8.4m was spent on the community while the value spent on the environment was not reported (probably nothing). The second company considered here was **International Breweries**. It reported a profit of ~~₦~~2, 506,490,000:00 after tax. On the employee, the number of physically challenged persons employed during the year was not reported. The sum of ~~₦~~10.72m was spent on the community while the value spent on the environment was not reported. It only reported that the company complied with US ten principles on environment. How they complied and amount spent on the environment was conspicuously absent from their 2013 Financial Statement and Report.

- **Petroleum Companies: SEPLAT Oil** reported a profit of ~~₦~~550,268m after tax. On the employee, the number of physically challenged persons employed during the year was not reported. On the community, the company organised health and educational programs. Education was given to 722 students at a cost of ~~₦~~19.3 million. Also skills acquisition training was given to youth. The company donated computers to the University of Benin, Department of Petroleum Engineering. The Company also initiated a state-wide educational programme. **Mobil Oil** Nigeria Plc reported a profit of ~~₦~~5,

123,002,000 after tax. On the employee, two physically challenged persons were employed during the year. On the employment the company reported that Employment opportunities are open to all suitable qualified Nigerians irrespective of their place of origin, religion or gender. The same opportunities are opened to qualified physically challenged persons. The value spent on the environment was not reported and even on the community was not reported.

- **Banking Sector: First Bank Plc** reported a profit after Tax ~~₦~~91,337,000. On the employee, Note 36 spoke about the amount spent on employee and the number employed for the year. Executive director – 19, Management 114 and non management 8,021. The sum of ~~₦~~ 52,138,000,000 was spent on them as salaries and wages (FBN, 2013). Amount spent on the community was not reported. What was done to the environment was conspicuously absent in the report. Did they do anything? Another bank considered was **ZENITH Bank Plc.**

The bank made the sum of ~~₦~~ 110,597m Profit before tax (continuing and discontinued operations). Amount spent on the community was ~~₦~~ 856m; on employee, the Bank's policy prohibits discrimination against disabled persons in the recruitment, and training and career development of its employees was done. On gender equality, going by 2013 report of the company, the ratio of gender employment stood at Male 52% Female 48%.

ERRORS IN SOCIAL AND ENVIRONMENTAL REPORTING IN NIGERIA

The standard of reporting on social and environmental issues is for an entity to report on the People (employee), Profit and the Planet. From the above analysis, most of the corporate entities in Nigeria are fair in dealing with the community in terms of donation made to the community, education given etc. On the first 'P' (people); these are the employees. Though many entities did not report on the number of physically challenged they employed but the emolument and staff training and development are always mentioned in companies' annual report.

Also, on the second 'P' which is report on profit; the annual financial statement and report had being doing that adequately for years now. The report always tells the public about the earnings – the profit and dividends. On the third 'P' which is the planet; it is a pity that a higher percentage of Nigeria corporate bodies neglect the report on the planet. Often times these companies' activities emit carbon dioxide into the air. Thereby cause air pollution. The oil spillage on the Nigeria sea side had sent many fishes to untimely death, thereby causing unemployment for the farmers. Big

companies like Mobil Nigeria Oil and First Bank Plc did not report on how they affected the planet positively in the 2013 annual report.

HINDRANCES TO CSR IMPLEMENTATION IN NIGERIA

It is on record that some corporate entities had invested much on CSR especially the gas and petroleum industries while some are yet to embark on CSR at appreciable level. Some of the factors hindering CSR in Nigeria as pointed out are:

- i. **Problem of CSR areas:** Many corporate bodies cannot easily identify areas in which they should invest into concerning social responsibilities in their host communities. This unidentified channel is a common problem in developing economics like that of Nigeria. Hence, the business entities are faced with barrage of demands from their host communities.
- ii. **Insurgents and Pressure Groups:** In the recent times Nigeria has being battling with the problems of insurgency and fighting from various pressure groups. This had led to unfriendly operating environment for the corporate bodies. Often times the little CSR projects that had been executed or ongoing are destroyed during crises from these insurgents and pressure group.
- iii. **Demands from the Shareholders:** There are often problems of who should be satisfied first in business decision. There are tripartite bodies in corporate entities. They are: shareholders, the employees and host communities. The shareholders want wealth maximization objectives to be pursued; the workers are majorly concerned with their welfare while the host communities want to be economically and ecologically satisfied. This a great challenged for CSR decision.
- iv. **The Population Explosion Problem:** The population on Nigeria had been increasing at an alarming rate. In 1991 the population stood at 88.9 million, in 2006 the figure rose to 140,003,542 million (an increase of 54.4%) (National Population Commission) and the figure for 2015 is 160,000,000. This rising in population is major concern for many corporate bodies in Nigeria as it is an additional responsibility on the management.
- v. **Wrong Notion of Who Should execute CSR:** Some corporate bodies believed that CSR are majorly the affairs of the government after their taxes had been paid to the government. On the other side the government is of the opinion that these corporate bodies are making enormous profit which

not only the shareholders should enjoy but the employees and their immediate communities should benefit from such jumbo profit.

SUMMARY CONCLUSION AND RECOMMENDATIONS

CONCLUSION

It is a pity that a higher percentage of Nigeria corporate bodies neglect the report on the planet when trying to report on Social and Environmental issues. Often times these companies' activities emit carbon dioxide into the air. Thereby cause air pollution. The oil spillage on the Nigeria sea side had sent many fishes to untimely death, thereby causing unemployment for the farmers. Big companies like Mobil Nigeria Oil and First Bank Plc did not report how they affected the planet positively in the 2013 annual report. Both policymakers and the public believe that companies have a moral responsibility to society. Most of the corporate bodies see CSR as only a Philanthropy gesture. The normal thing is for companies to offer certain benefits to their employees and the communities where they operate that will lead to strong economic platform that will pave way to future good Gross Domestic Product of the country.

The cooperation the Nation is receiving from the International development is on the poor side. Since the influence of the International development organisation is not encouraging, attentions of the Nation should be on the foreign companies to be socially responsible. Often times CSR activity is discussed by Non Governmental Organisations (NGOs) and the media, but not by the wider public at large. This means that it is only certain members of civil society and the political community that have recognized that CSR can be an essential component of sustainable economic development. Often times because of Nigeria's high poverty rate – over 50 percent companies are asked to help meet short-term needs. This action does not allow for long-term planning. There is often no formal meetings or forum to meeting the community and even their employees to deliberate on the CSR policies of the organisation.

As expected with young democracy which is about 15 years (1999 to 2014), the nation is often battling with political and religious upheavals. Nigeria is regularly confronted with threats to its security and the stability of

the political order. The issue of Niger Delta tensions is just dying down while that of Boko Haram violent conflict with Nigeria is currently taking uncontrollable dimension. All these factors are not helping the CSR activities in Nigeria.

RECOMMENDATIONS:

- Corporate bodies in Nigeria need to be more socially responsible by involving in technological excellence and innovations, public private partnership, community development foundations and sustainable development.
- Companies should have much appreciation of strategic importance of building business practices that create sustainable economies and environments. This is a holistic approach to corporate social responsibility; and not just a philanthropy gesture to spend part of the company's profit back to the society.
- The corporate and non corporate organisation in Nigeria should take the lead in initiating sustainable conversations on CSR through period magazines. Also there should be a link between the corporate culture, employee relation policies, product development and service delivery guidelines or customer engagement practices and their CSR activities.
- The organizations in Nigeria should take the ethnicity and religious beliefs of the country into consideration when considering CSR. Nigeria has over 250 ethnic groups with various religions varying from Christianity, Islam, and animism to traditional beliefs. All these factors should be considered in implementing CSR.
- There are several different ways that companies express their corporate social responsibility. Commitment to CSR should include the use 100 percent clean energy, production of zero waste, fuelling with clean energy e.g. wind energy and health hazards free environmental are promises that responsible companies make to their communities.
- Nigerian consumers of various goods should become more enlightened, more critical and more demanding of the government and corporate organisations. Buyers should choose to make their purchases from entities

that are tends to be more customer-oriented and affect positively the environment in which they operate.

- Employees' safety and good health environment should be enhanced by government policies on employees' safe working environment and modern health facilities.
- To be on the safer side, every corporate body in Nigeria should pursue their CSR very well in: responsibilities towards shareholders wealth maximization, superb management-employees relationship, perfect responsibilities to consumers, meeting the statutes enacted and make their host communities happy.
- The government must as matter of policy come out with relevant laws, policies and other controls to guide and monitor CSR in the country.

This paper posits that many companies in Nigeria are not doing enough in their corporate social responsibility. More alarming is the fact most of them neglect the report on their environment in their annual report. The corporate entities should note that that the leading Nigeria companies in year 2020 will be those that are socially responsible, and those that can address the current political and economy debacles of the Nation. The surviving companies in 2020 will be those that have respect for natural systems and international standards protecting core social and environmental values .The main conclusion of this paper is that CSR is an integral part of the new business model and that it is increasingly recognized that the role of the business sector is critical. As a part of society, it is in business' interest to contribute to addressing common problems. Strategically speaking, business can only flourish when the communities and ecosystems in which they operate are healthy.

REFERENCE

Andreas, W. and R. B. & Handfield (2013): The Socially Responsible Supply Chain: An Imperative for Global Corporations. *Supply Chain Management Review, Vol. 17, No. 5, pp. 22-29.*

Bertelsmann, s. (2012). CSR WeltWeit: German Business - Global Citizen <http://www.csrweltweit.de/en/laenderprofile/profil/nigeria/index.nc.html> (retrieved 31/01/2015)

- Bhattacharya, C.B., Sankar, S. & Daniel, K, (2008). "Using Corporate Social Responsibility to Win the War for Talent," *MIT Sloan Management Review*, 49 (2), 37-44; "The Good Company". *The Economist*. 2005-01-20. Retrieved 2008-03-07
- First Bank Nigeria Plc, (2013), First Bank of Nigeria, 2013 Financial Statement and Annual Report
- Wood, D. (1991) 'Corporate Social Performance Revisited' - 199116(4) *The Academy of Management Review*
- DeGeorge, R. T. (2010). *Business Ethics*. 7th. Upper Saddle River: Pearson Education, Inc. , 2010. 205. Print.
- Halpern, B., & Keith, F. S (2012). "Products that Kill and Corporate Social Responsibility: The Case of US Defense Firms". *Armed Forces & Society* **38** (4): 604–624.
- Halpern, B., & Keith, F. S. (2012). "Products that Kill and Corporate Social Responsibility: The Case of US Defence Firms". *Armed Forces & Society* **38** (4): 604–624.
- Henderson, D. (2001). *Misguided Virtue: False Notions of Corporate Social Responsibility*. *Institute of Economic Affairs*. p. 171. ISBN 0-255-365101.
- Korschun, D., Bhattacharya, C.B. & Scott, S. (2011). "When and How Does Corporate Social Responsibility Encourage Customer Orientation? Working Paper". Esmt.org.
- McWilliams, A., & Siegel, D (2001). "Corporate social responsibility: A theory of the firm perspective". *Academy of Management Review* **26**: 117–127.
- McWilliams, A., & Siegel, D. (6 April 2000). "Corporate social responsibility and financial performance: correlation or misspecification?". *Strategic Management Journal* **21** (5): 603–609. doi:10.1002.
- McWilliams, A., Siegel, D., & Wright, P. M. (March 2006). *Corporate Social Responsibility: International Perspectives* (PDF). Working Papers

(0604). Troy, New York: Department of Economics, Rensselaer Polytechnic Institute.

Paul, H. (2012) *Corporate Social Responsibility: An Implementation Guide for Business*. International. Institute for Sustainable Development. International Institute for Sustainable Development. ISBN 978-1-895536-97-3 http://www.iisd.org/pdf/2007/csr_guide.pdf

Rosenberg, M. J. (1 April 2002). "Review of *Misguided Virtue: False Notions of Corporate Social Responsibility*". *International Affairs*.

Samuelson, S. S. (2009). *Introduction to Business Law*. Cengage Learning.

Shamir, R. (2011) Socially Responsible Private Regulation: World Culture or World- Capitalism? *Law and Society Review*, 45, 2, 313-336.

Shumate, M., & O'Conner, A. (2010): "The symbiotic sustainability model: Conceptualizing NGO-corporate alliance communication". *Journal of Communication* **60** (3): 577–609. doi:10.1111/j.1460-2466.2010.01498.x.

Zenith Bank, (2013): Zenith Bank of Nigeria, *2013 Financial Statement and Annual Report*

Authors' Profile:

1. **Mamidu Aruna Ishola (ACA)**: He is a lecturer with Achievers University in Owo, Ondo State. He is a Chartered Accountant as well as a voracious researcher. He has two local and nine international publications in reputable journals to his credit. He is currently on his post graduate study in Benson Idahosa University, Benin City.

2. **Adetula S. L.**: He is a lecturer with Achievers University in Owo, Ondo State. He is an academician per excellence. He has publications in reputable journals to his credit. He is currently on his Doctorial Academic pursuit with Igbinedon University.

3. **Abu J. A (ACA)**: He is a lecturer with Achievers University in Owo, Ondo State. He is a Chartered Accountant with outstanding academic records. He has many publications in reputable journals to his credit.

IMPACT OF CORRUPTION IN NIGERIAN STOCK MARKET – Nageri, K. I.

*Department of Banking and Finance,
Al-Hikmah University, Ilorin, Nigeria.
P.M.B 1601, Ilorin Kwara State, Nigeria.
nagerisuccess2000@yahoo.co.uk*

ABSTRACT

Corruption has attracted a lot of research attention in recent year due to its perceived empirical negative effect on economic growth and development. This paper examines the empirical impact of corruption in stock market, using country specific data from Nigeria. Theoretical econometrics model of simple equation regression of Ordinary Least Square (OLS) and the Augmented Dickey Fuller (ADF) test of stationary were used to establish the impact of corruption in Nigeria stock market. Secondary data were sourced from Central Bank of Nigeria statistical bulletin and corruption reports from Transparency International on Nigeria between the periods of 1996-2013 were used. Market capitalization in million naira and All Share Index are proxies for Nigerian stock market, while Corruption Perception Index (CPI) is the proxy for corruption. Findings indicates that there is a significant statistical positive impact of increase in corruption perception index on the Nigerian stock market and the robustness test shows that the residual has no autocorrelation either positive or negative, normally distributed and it's homoscedastic which are all desirable.. The Akaike and Schwarz information criterion indicates that the MCAP model is a better model than the ASI model. The results agree with the theoretical and empirical findings in recent literatures. The regulatory agencies in the financial sector such as the Securities and Exchange Commission (SEC) are therefore advised to intensify their fight against corruption in the financial sector especially the Nigerian Stock Exchange in order to improve the corruption perception index of Nigeria and this will boost investors' confidence at both local and international sphere.

KEYWORDS: *Corruption perception index, Market capitalization, All Share Index, Nigeria.*

Word count: 256

1. INTRODUCTION

Corruption, a previously neglected issue, has become one of the greatest preoccupations of developing and developed economies' governments that want to bring stability and prosperity to their financial market and their economy as a whole. Corruption has attracted a lot of research attention in recent year due to its perceived empirical negative effect on economic development. Numerous studies have investigated the effect of corruption on economic growth and many of these works have found negative impact of corruption on growth and development such works includes among others Adewale (2011), Fabayo et al (2011), Akindele (2005), Nageri et al (2013). In the same vein, capital market development and performance has also receive attentions of researchers and has also been found to have positive impact on economic growth and development (Hearn and Piesse, 2010; Levine and Zervos, 1998 among others).

The connection between corruption and stock market become an important area of research because a corrupt capital market will, empirically, crumbles the potential of the capital market as an institution that can foster economic growth and development (Ayaydin and Baltaci, 2013). Corrupt practices, such as over-invoicing, breach of financial guidelines, multiple payments, falsification of accounts, illegal sharing of funds and fragrant disregard for budgets and expenditure limits, undisciplined spending by regulatory agency can lead to round-tripping, questionable transactions, short selling, insider trading, outright fraud and price manipulation will certainly erode investors' faith in the stock market.

In line with the above statement, the main objective of this study is to examine the impact of corruption on the Nigerian stock market. The study will provide answers to the following questions: (i) What is the magnitude of the impact of corruption on the Nigerian stock market? (ii) How can corruption be curbed in the Nigerian capital market? Among other answers

Therefore, the aim of this study is to provide an empirical evidence of the impact of corruption on stock market in Nigeria. This paper, however, uses country specific data to determine the relationship between corruption and capital market and it is presumed that fight against corruption will positively influence stock market based on apriori economic theory. Market capitalization and all share index are proxy for stock market while Corruption Perception Index is the proxy for corruption. The study covers a sample

period of 1996 to 2013. The rest of this paper is divided into: section 2: literature review, section 3: methodology, section 4 focuses on analysis of findings and section 5 provides summary, conclusion and recommendations.

2. LITERATURE REVIEW

Literatures on the issue of corruption are abound because of its impact on economic development but there exist little research literatures on the concepts, determinants, severity and implications of corruption on capital market performance. The reason has been identified as non-readily available data, particularly when the need to pin- point the size of corruption and the people that engaged in it arises. It is only recently, in 1995 when Transparency International (T.I) started providing a measure of corruption on countries around the world and Nigeria started featuring a year later.

According to Fabayo, et al (2011), corruption takes place when an individual adopts an unapproved and unfair method to obtain some benefits, whether as a taker or a giver, through socially and legally prohibited course of action(s). Every bad act or bad behavior is thus linked to and/or termed as corruption. Such approach looks rather general and vague because it will be practically difficult to capture the effect of every bad act particularly at the macroeconomic level. However, the effect of corruption can indeed be grave on the performance of business entities and the economy at large. In support of this, Nageri, et al (2013), finds out that corruption has a significant negative effect on economic growth and development. Also, Ogbeidi (2012), examined political leadership and corruption in Nigeria since 1960, he opined that it is an incontrovertible fact that corruption has been the bane of Nigeria's development. According to Ekpo and Egbenebo (1985), Obadan (2002) and Adewale (2011), corrupt practices inherently introduce distortions in the economic system, it impairs hard work, diligence and efficiency. It is capable of diverting resources meant for the development of the society to private or personal use. They maintain that corruption does not give room for honest selection processes and also distort prices.

There have been numerous studies examining relationship between stock market development and economic growth, Kemboi, et al (2012), established that there is bi-directional Granger causality between stock market development and the macroeconomics variables captured (stock market liquidity, income level, and banking sector) in the estimation based on the F-statistics. Similarly, the Wald test of joint significance of the model also implies Granger causality, and so the null hypothesis 'Granger no-

causality from stock market development to macroeconomic variables' was rejected at 5 percent level of significance. Another research by Ewah, et al (2009) study the impact of the capital market on economic growth in Nigeria using time series data from 1963-2004. They conclude that capital market in Nigeria has the potential to contribute to growth of the Nigerian economy but has not done so due to, among other reasons, illiquidity and corruption in the system. The recent financial crisis has made the Nigerian capital market illiquid and this has caused the downward trend in the market. In turn, the capital market is becoming less attractive to long-term investors and very risky to invest in.

On corruption-capital market nexus, Ayaydin, et al (2013) finds out that some countries have highly developed stock markets, but some other countries have less developed stock market while the results for stock market development model show that corruption level is significantly and negatively associated with stock market development in both countries. In the same vein, Fabayo et al (2011) using multiple regression model, asserts that corruption deters investment and thus hinders economic growth in Nigeria while other variables in the model, Openness to international trade and minimum wage separately have a positive effect on investment. Jain, et al (2012), also finds out that corruption decreases liquidity available to institutional traders and discouraged foreign portfolio investment inflows into the country. Risks and cost of equity capital were also found to be negatively affected by corruption. These effects were true both at national and firm levels.

3. METHODOLOGY

The Augmented Dickey-Fuller (ADF) stationary test and the Ordinary Least Square (OLS) technique were used to analyse the secondary time series data employed for the study. Data was sourced from the Central Bank of Nigeria statistical bulletin and Transparency International (TI). The sample covers a period from 1996 – 2013 because of the availability of the required data for this paper.

3.1 Model specification

The models used for this research, in their functional forms are express as:

$$\text{MCAP} = F(\text{CPI})$$

$$\text{ASI} = F(\text{CPI})$$

Where MCAP = Nigerian Stock Market Capitalisation in Billion Naira, ASI = All Share Index of the Nigeria stock exchange and CPI = Corruption Perception Index on Nigeria.

The linear form of the models is expressed as:

$$MCAP = \beta_0 + \beta_1CPI$$

$$ASI = \alpha_0 + \alpha_1CPI$$

Their econometric form is written as:

$$MCAP = \beta_0 + \beta_1CPI + \mu$$

$$ASI = \alpha_0 + \alpha_1CPI + \mu$$

Where β_1 and α_1 represents the coefficients of the independent variables, β_0 and α_0 are the constants and μ represents the disturbance terms. MCAP and ASI are the dependent variables (Market Capitalisation and All Share Index) used to measure Nigeria capital market while CPI is the corruption perception index used to measure corruption as the independent variable.

3.2 Apriori expectation

The apriori expectation set by economic theory for this research is expected to be as follows for the parameters:

$$\beta_1 > 0 \text{ and } \alpha_1 > 0$$

The above simply means that increase in corruption perception index for Nigeria is expected to positively impact the performance of the Nigerian stock market. This is because an increase in Transparency International (T.I) corruption perception index translates to mean less corruption in such country. The parameters for the estimation are β_1 and α_1 .

4. DISCUSSIONS OF FINDINGS

The following are the data used in this paper.

Table 1: Data used for this study:

Year	MCAP	ALSI	CPI
1996	285.800	5955.142	9.6
1997	281.900	7638.592	17.6
1998	262.600	5961.875	19
1999	300.000	5264.192	16
2000	472.300	6701.175	12
2001	662.500	10185.08	10
2002	764.9000	11631.87	16
2003	1359.300	15559.90	14
2004	2112.500	24738.65	16

2005	2900.060	22876.72	19
2006	5120.900	27647.51	22
2007	13181.69	48773.31	22
2008	9562.970	50424.70	27
2009	7030.840	23091.55	25
2010	9918.210	24775.59	24
2011	10275.34	23393.65	24
2012	14800.94	23432.62	27
2013	19077.42	36207.08	25

Source: Transparency international annual reports, Nigeria stock exchange fact books and CBN Statistical Bulletin.

MCAP = Market Capitalisation in billion Naira, CPI= corruption Perception Index.

ASI = Annual Average of All share index.

4.1 Unit root test

Table 2: Augmented Dickey-Fuller test statistics

Variables	ADF	1%	5%	10%	P-Value
ASI	- 1.413113	- 3.886751	-3.052169	-2.666593	0.5512
1 st Differenced ASI	- 3.481326	- 3.920350	-3.065585	-2.673459	0.0231*
CPI	- 1.709538	- 3.886751	-3.052169	-2.666593	0.4091
1 st differenced CPI	- 4.527239	- 3.920350	-3.065585	-2.673459	0.0031*
MCAP	- 0.446549	- 3.886751	-3.052169	-2.666593	0.9788
1 st differenced MCAP	- 3.640166	- 3.920350	-3.065585	-2.673459	0.0171*

*significant at 5%

Source: Authors computation, 2015.

The ADF statistics was used to test for stationarity of the time series data in order to establish the order of integration of them to avoid a spurious regression line. It is observed from the ADF statistics that the time series data are of the same order of integration because they are not stationary at level, but they all become stationary at first difference which means that the data are integrated of the same order. This satisfies one of the conditions for

the use of the Ordinary Least Square (OLS) regression technique that the variables must be integrated of the same order (stationary at the same level).

4.2 Regression results

Table 3 (Model 1)

Dependent Variable: MCAP

Method: Least Squares

Date: 02/17/15 Time: 17:47

Sample: 1996 2013

Included observations: 18

Variable	Coefficient	Std. Error	t-Statistic	Prob.
	-			
C	10924.27	3127.257	3.493243	0.0030
CPI	854.5973	156.7999	5.450242	0.0001
R-squared	0.64993	Mean dependent	5465.0	
Adjusted R-squared	0.62805	S.D. dependent	5973.1	
S.E. of regression	3642.86	Akaike info	19.343	
Sum squared resid	2.12E+08	Schwarz criterion	19.442	
Log likelihood	172.0903	Hannan-Quinn	19.357	
F-statistic	29.7051	Durbin-Watson	1.3565	
Prob(F-statistic)	0.000053		16	

Source: *Eviews output computed by the author, 2015*

The regression result of table 3 indicates that CPI, the proxy for corruption is statistically significant to market capitalization with the P-value at 0.0001 and a co-efficient of 854.5973 means that an increase in CPI for Nigeria will positively impact the market capitalization, a proxy for stock market by an estimated value of #854.59Billion annually.

The R² shows that corruption explains 65% variation in stock market capitalization while the adjusted R² shows that if other variables were to be included in the model, corruption will still explain 63% variation in stock market capitalisation. This means that eradication of corrupt practices in the Nigerian stock market can facilitate the positive potential of the market in fostering economic growth and development. The F- statistics is 29.71 which is not too large, shows that the model is statistically significant with a P-value of 0.000053. This leads to the rejection of the H₀: corruption has no statistically significant effect on stock market in Nigeria.

Table 4 (Model 2)

Dependent Variable: ALSI

Method: Least Squares

Date: 02/17/15 Time: 17:25

Sample: 1996 2013

Included observations: 18

Variable	Coefficient	Std. Error	t-Statistic	Prob.
	-			
C	12687.5	68670.156	1.463360	0.1627
CPI	1745.75	7434.7195	4.015824	0.0010
R-squared	0.50197	Mean dependent	20792.	
	4var		18	
Adjusted R-squared	0.47084	S.D. dependent	13884.	
	7var		03	
S.E. of regression	10099.6	Akaike info	21.382	
	4criterion		83	

Sum squared resid	1.63E+0	Schwarz	21.481
	9	criterion	76
	-		
	190.445	Hannan-Quinn	21.396
Log likelihood	4	criter.	47
	16.1268	Durbin-Watson	1.1627
F-statistic	4	stat	17
	0.00099		
Prob(F-statistic)	8		

Source: *Eviews output computed by the author, 2015*

The result of the regression in table 4 also shows that CPI, the proxy for corruption is positively statistically significant to all share index with the P-value at 0.0010 and a co-efficient of 1745.757 means that an increase in CPI for Nigeria will positively impact the all share index, a proxy for capital market by an estimated value of 1745.757 basis points annually.

The R^2 shows that corruption explains 50% variation in the all share index of the Nigerian stock exchange while the adjusted R^2 shows that if other variables were to be included in the model, corruption will still explain 47% variation in the stock market. This means that fighting corrupt practices in the Nigerian stock market can boost the positive potential of the market in fostering economic growth and development. The F- statistics is 16.12 which is not too large, shows that the model is statistically significant with a P-value of 0.000998. This leads to the rejection of H_0 : corruption is not statistically significant to stock market in Nigeria.

4.3 Model appropriateness test

There are some features that these models should satisfy in order to be appropriate for policy consideration and implementation, these are that the residuals must be normally distributed, absence of autocorrelation, no serial correlation, homoscedastic, etc. in this study these tests were conducted on the residuals to decide if these models are robust.

4.3.1 Model 1

Normality test

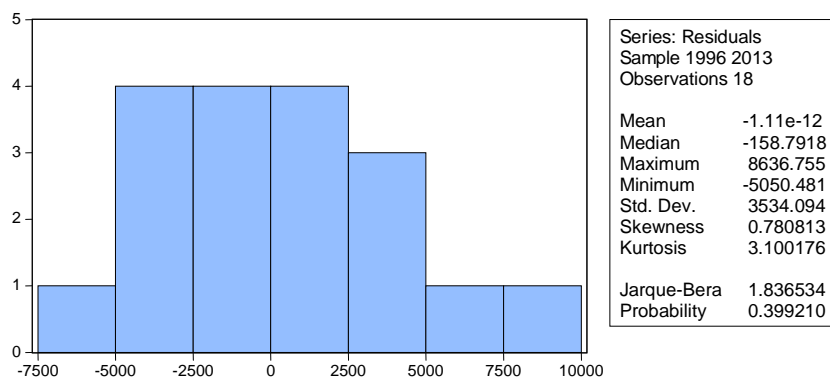

Source: *Eviews output computed by the author, 2015*

Serial correlation test

Breusch-Godfrey Serial Correlation LM Test:

	0.60374		
F-statistic	3	Prob. F(2,14)	0.5604
	1.42921	Prob. Chi-	
Obs*R-squared	4	Square(2)	0.4894

Source: *Eviews output computed by the author, 2015*

ARCH test

Heteroskedasticity Test: ARCH

	0.41315		
F-statistic	3	Prob. F(2,13)	0.6699
	0.95621	Prob. Chi-	
Obs*R-squared	4	Square(2)	0.6200

Source: *Eviews output computed by the author, 2015*

The Jarque-Bera residual normality test result for model 1 is 1.836534 with a P-Value of 39.92% which is more than 5% indicates that the null hypothesis cannot be rejected, meaning that the residuals are normally distributed. The Breusch-Godfrey serial correlation LM test shows a P-Value of 49% for the observed R^2 which means we cannot reject null hypothesis that the residuals are not serially correlated. The Heteroscedasticity test also shows a P-Value of 62% for the observed R^2 meaning that the null hypothesis that the residual has no ARCH effect cannot be rejected. All these tests confirm that the model is robust for policy consideration.

4.3.2 Model 2

Normality test

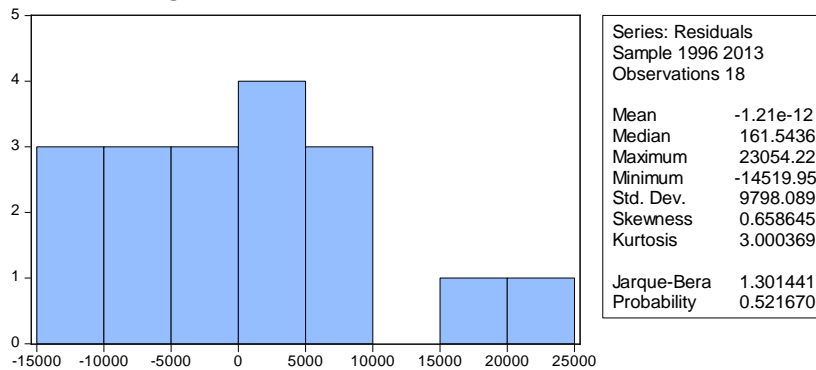

Source: *Eviews output computed the author, 2015*

Serial correlation test

Breusch-Godfrey Serial Correlation LM Test:

	2.12285		
F-statistic	5	Prob. F(2,14)	0.1566
	4.18853	Prob. Chi-	
Obs*R-squared	4	Square(2)	0.1232

Source: *Eviews output computed by the author, 2015*

ARCH test

Heteroskedasticity Test: ARCH

	1.03383		
F-statistic	4	Prob. F(2,13)	0.3831
	2.19560	Prob. Chi-	
Obs*R-squared	8	Square(2)	0.3336

Source: *Eviews output computed by the author, 2015*

The Jarque-Bera residual normality test result for model 2 is 1.301441 with a P-Value of 52.16% which is more than 5% also indicates that the null hypothesis cannot be rejected, therefore, the residuals are normally distributed. The Breusch-Godfrey serial correlation LM test indicates a P-Value of 12.32% for the observed R^2 which means the null hypothesis cannot be rejected that the residuals are not serially correlated and the Heteroscedasticity test shows a P-Value of 33.36% for the observed R^2

indicates that the null hypothesis that the residual has no ARCH effect cannot be rejected. These tests indicate that this model is also robust for policy consideration and is consistent with the first model.

5. SUMMARY, CONCLUSION AND POLICY RECOMMENDATION

This paper has been able to show, empirically, that corruption is statistically significantly affecting the stock market in Nigeria and fighting corruption can enhance the potential of the stock market as an agent of economic growth and development. It was found out that an estimated #854.59 Billion in market capitalization can be gained and an increase of 1745.757 points in the all share index of the Nigerian stock exchange if corruption perception index of Nigeria can be improved through the eradication of corrupt practices in the country and the capital market, these findings is supported by the works of Ayaydin et al (2013), Samadi et al (2011) and Igbokwe (2009). The result also shows that 50% - 56% variation in capital market performance is explained by corruption which also agrees with the finding of Abdul-Qadir et al (2013) which shows 53% correlation between market capitalization and corruption. The models are found to be robust for policy consideration because the residuals are normally distributed, no autocorrelation and they are homoscedastic which are all desirables of any good model.

In conclusion, corruption perception of Nigeria has been found to be statistically affecting the Nigerian stock market and this is affecting the potential of the market as an agent of economic growth and development in Nigeria. The study also finds out that corruption of many types such as bribery, fraudulent acts, embezzlement of public and private funds and property, election rigging and ballot stuffing, money laundering, examination malpractices in schools of privately and publicly owned, are some forms of corrupt practices perpetrated in Nigeria.

Finally, the recommendation is that corrupt practices that are related to the performance of the capital market such as over-invoicing, breach of financial guidelines, multiple payments, falsification of accounts, illegal sharing of funds and fragrant disregard for budgets and expenditure limits, undisciplined spending by regulatory agency among others should be checked and perpetrators should be prosecuted. By so doing, individuals or group who engaged in other corrupt practices such as round-tripping, questionable transactions, short selling, insider trading, outright fraud and

price manipulation would be cautious and preventive against corrupt practices. This will improve both local and international investors' confidence in the Nigerian capital market.

REFERENCES

Abdul-Qadir, A. B and Yaroson, E. (2013). Does Corruption Matter in the Development of the Stock Market in Nigeria? *ESUT Journal of Accountancy*. Vol.4(1) Pp. 01-020.

Adewale, S.B. (2011). The crowding-out effects of corruption in Nigeria: An empirical study. *Journal of Business Management and Economics*. Vol.2(2) Pp. 059-068.

Akindele, S.T. (2005). A Critical Analysis of Corruption and its Problems in Nigeria. *Anthropologist*. Vol.7(1) Pp. 07-018.

Ayaydin, H. and Baltaci, N. (2013). Corruption, banking sector, and stock market development: A panel data analysis. *European Journal of Research on Education, Special Issue: Human Resource Management*, Pp. 94-99

Ekpo, H.A. & Agbenebo, T. (1985). Corruption and Prices: A Theoretical Note. *The Nigeria Journal of Economics and Social Studies*. 27(3) Pp. 306-316.

Ewah, S. O. E., Esang, A. E. and Basse, J. U. (2009). Appraisal of Capital Market Efficiency on Economic Growth in Nigeria. *International Journal of Business and Management*. December, Pp. 219-225.

Fabayo, J.A., Posu, S.M.A., and Obisanya, A.A. (2011). Corruption and the Investment Climate in Nigeria. *Journal of Economic and Sustainable Development*. Vol.2(4).

Hearn, B. and Piesse, J. (2010). Barriers to the Development of Small Stock Markets: A Case Study of Swaziland and Mozambique. *Journal of International Development*. Vol.22 Pp. 1018-1037.

Igbokwe, V., (2009). A Post-Mortem of the Meltdown of the Nigerian Stock Exchange: Are weak regulatory framework & corrupt officials to blame?

Blackfriars Newsletter, May, Vol.22(5). www.blackfriars-law.com accessed on 8/5/2013

Jain, P. K., Kuvvet, E. and Pagano, M.S. (2012) Corruption's Impact on Liquidity, Investment inflows and Cost of Capital. www.lehigh.edu.

Kemboi, J.K. and Tarus, D.K (2012). Macroeconomic Determinants of Stock Market Development in Emerging Markets: Evidence from Kenya. *Research Journal of Finance and Accounting*. Vol 3(5) Pp. 057-068

Levine,R. and Zervos, R. (1998) Stock Markets, Banks and Economic Development. *American Economic Review*. Vol.88 Pp. 537-558

Nageri, K.I., Gunu, U., and Abdul, F.A (2013). Corruption and Economic Development: Evidence from Nigeria. *Kuwait Chapter of Arabian Journal of Business and Management Review*. Vol.3(2) Pp. 046-056.

Obadan, M. (2002). *Corruption, Public Investment and Growth in Nigeria: Some Stylist Facts*. NESG Economic Indicators. Vol.2(2).

Ogbeidi, M. M. (2012). Political Leadership and Corruption in Nigeria since 1960: A Socioeconomic Analysis. *Journal of Nigeria Studies*. Vol.1(2) Pp. 01-025.

Samadi, S., Fathi, S. and Tahmasebi, S (2011). Impact of Foreign Direct Investment on Financial Development Present to Political Corruption in the Countries of D-8. *Interdisciplinary Journal of Contemporary Research in Business*. Vol.3(5) Pp. 445-450.

BOARD ATTRIBUTES AND CORPORATE FINANCIAL PERFORMANCE OF NIGERIAN QUOTED COMPANIES

Ruth. O. Urhoghide, Augustine. E. Akhidime (Ph.D.)
Department of Accounting, Benson Idahosa University,
Benin City, Edo State

&

Augustine. E. Akhidime (Ph.D.)
Department of Accounting, Benson Idahosa University,
Benin City, Edo State

ABSTRACT

The broad objective of the study is to examine the effect of board attributes on financial performance of selected quoted companies in Nigeria. Specifically, the study examines if the size of the board, the board independence, board financial expertise and CEO duality exert a significant influence on the financial performance of quoted companies. Financial performance of companies was measured using Profit after tax and Return on equity. The study used secondary data sourced from companies quoted on the Nigerian stock exchange. A total number of 50 companies with data span from 2008-2013 was selected across four (4) sectors namely; agricultural sector, conglomerates, construction and brewery. The Ordinary Least Squares Regression was adopted as the data estimation technique. Preliminary statistics such as the descriptive and correlation analysis was also conducted. The estimation is conducted on a sectorial and then full sample basis. Using PAT as the profitability measure, the results revealed that Board size is significant for the full sample estimation and for construction sector. Board independence is significant for full sample and for companies in conglomerates and breweries sector. Board financial expertise and CEO duality were significant for full sample but also varies in the sectorial analysis. A similar pattern in the results was also observed when PAT was substituted with ROE as the financial performance measure. The study concludes that board attributes will play an incrementally relevant role in financial performance of companies. Hence companies should pay detailed attention to the board attributes.

1. INTRODUCTION

Corporate governance has been part of research since Berle and Mean's (1932) classic publication of the "separation of corporate ownership from control". The importance of effective corporate governance to corporate and economic performance cannot be overemphasized in today's business environment. Consequently, the subject of corporate governance has attracted a good deal of public interest because of its apparent importance for the economic health of corporations and society in general. Several definitions have emerged in order to provide an adequate conceptualization of corporate governance. In this regards, Babatunde (2003) defines Corporate Governance as the stewardship of an organization in terms of the way it is run, (directed and controlled). It is concerned with the respective roles, powers, responsibilities and accountability of stakeholders and the board. The Organization for Economic Cooperation and Development (OECD, 1999) defines corporate governance as the system by which business corporations are directed and controlled. Interestingly, the role of corporate governance has been identified as critical to the firm performance. This is because the opportunistic tendency of managers to engage in unethical practice is reduced in the presence of effective corporate governance structure.

The Board of directors is a key component of the corporate governance system. In fact corporate governance is most evaluated using the structure of the board and this has been the tradition in corporate governance research. Prior research on Board attributes and firm performance has suggested multiple ways in which boards may contribute to organizational effectiveness (Forbes and Milliken, 1999). From a resource dependence perspective, boards strengthen ties with the external environment by generating business ties and maintaining a positive corporate image. Boards are also thought to contribute to the development of better organizational strategies. Johnson, Daily and Ellstrand (1996) argue that effective boards allow top managers to tap the breadth of knowledge possessed by outside directors to complement the depth of firm-specific knowledge of executives. Using a collaborative approach, boards are given the ability to advise, deliver feedback, and enhance strategy formulation (Sundaramurthy and Lewis, 2003).

From an agency/control perspective, effective boards provide a necessary check on top management, providing oversight and tying

executive rewards to performance (Sundaramurthy and Lewis, 2003). Generally speaking, boards are expected to evaluate company and CEO performance and take action when needed to protect shareholder interests (Golden and Zajac, 2001). Thus, board attributes across a broad range should be related to company performance (Sundaramurthy and Lewis, 2003). As research on boards continues to progress, there is increasing evidence that governance structures are interdependent, both affecting and substituting for each other in such a way that multiple governance mechanisms and structures might be effective (Daily, Dalton and Cannella, 2003).

Though several studies exist that have examined the relationship between corporate governance and specific board attributes on firm performance most of these studies have clustered companies together in conducting their estimations. We argue that there may be some inherent weakness and bias in the results given that corporate governance regulation may differ from industry to industry and also certain industries may be more intensely regulated than others. Financial sector for example in Nigeria have specific governance requirements that may not apply to other industries. Also research into board attributes and firm performance appear scarce for certain sectors like Agricultural sector and breweries. This study attempts to address these issues by providing empirical evidence on the link between board attributes and firm performance using a multi-sectorial analysis approach.

2. LITERATURE REVIEW AND HYPOTHESES

In this section, the empirical literature on the effect of board attributes on firm performance is examined and the hypothetical relationship is presented:

2.1 Board Size

Amran (2011) empirically studied the association between Corporate Governance Mechanisms and Company Performances. It was expected that corporate governance mechanisms affect company performance. The hypothesis was tested on 424 public listed Malaysian Companies (233 family controlled firms and 191 non-family controlled firms) and the data about corporate governance mechanisms and company's performance was collected from Sultanah Bahiyah Library database from the year 2003 to 2007. Panel data methodology with generalized least square estimation method was used to test the hypothesis. The analysis has been done by classifying the sample as family controlled firm and non-family controlled firm. The researcher found

that Board size has a significant negative influence on family controlled firms performance but insignificant for non-family controlled firms.

Al-Manaseer, Al-Hindawi., Al-Dahiyat & Sartawi, (2012), empirically investigated the impact of corporate governance on performance using 15 Jordanian banks listed at Amman Stock Exchange from the year 2007 to 2009 with a total of 45 bank-year observation. The study employed pooled data, and OLS estimation method with panel methodology. Return on asset, return on equity, profit margin (measured as net interest income divided by total asset) and earning per share were the dependent variables of the study. The study revealed a significant negative relation between board size and banks performance as measured by return on equity and earning per share but insignificant negative association of board size with return on asset and profit margin was found.

Babatunde and Olaniran (2009) analyze the effects of internal and external governance mechanism on performance of corporate firms in Nigeria. In the study panel data regression analysis was used with a sample of 62 firms listed on the Nigerian Stock Exchange for a period of five years from 2002 to 2006 to examine the relationship between internal and external governance mechanisms and corporate firms' performance. The researchers found a positive and significant relationship between board size, block shareholders and leverage and the dependent variable Tobin's Q. However, the study revealed an inverse relationship between director's shareholdings, firm size, independence of the audit committee and the numbers of outside directors on board. When the return on asset was used as the dependent variable significant positive relationship of board size, block holders and leverage with return on asset was found. However, there was a negative relationship between the number of outside directors on board, director's shareholdings, independence of the audit committee, firm size and the return on asset. In addition, the study found that the measure of performance matter for analysis of corporate governance studies. In some cases different result were obtained based on the measure used.

Aljifri and Moustafa (2007) provided evidence on the impact of corporate governance mechanisms on firms' performance using 51 United Arab Emirates listed firms by using both accounting and market data for the year 2004. They have employed cross-sectional regression analysis to test whether the selected corporate governance variables have an impact on firms' performance or not after controlling firm size. The results of the study showed that board size, have insignificant effect on firms' performance.

Adusei (2011) investigated the relationship between board structure and bank performance with panel data from the banking industry in Ghana by implementing estimation method of regression in pooled OLS. A total sample of 17 out of 26 universal banks was used in the study. The researcher used return on asset and cost income ratio as dependent variable of the study and board size and board independence as independent variable of the study. The study found that as the size of a bank's board of directors decreases its profitability increases. He recommended that banks seeking some improvement in their performance should constitute small sized boards of directors composed of few independent directors.

H1: There is a positive significant relationship between Board size and firm performance.

2.2. Board Independence

Abu-Tapanjeh (2006) analyze the association between good corporate governance mechanism and firms' operating and financial performance by employing multiple regression models with panel data set based on 39 industrial companies listed in Amman Stock Exchange of Jordan, over the period of 1992 to 2004. Using net sales to operating cost ratio and dividend payout ratio were used as a measure of firms' operating and financial performance, the study found that the proportion of outside directors positively and significantly influences firms' performance both operating and financial.

Al-Hawary (2011) examined the effect of banks governance on banking performance by taking all Jordanian commercial banks listed in Amman Stock Exchange i.e. 13 banks. The researcher employed multiple regression models to measure the influence of corporate governance variables on banks performance by controlling bank's size. According to the study percentage of non-executive directors had statistically significant positive effect on Tobin's Q.

H2: There is a positive significant relationship between Board independence and firm performance.

2.3. Board Expertise

On the importance of board members' expertise, Bosak and Blinka (2010:15) articulate that: *'Boards must understand the complete risk profile of their individual company and its related industry ... Corporations must narrow the knowledge gap by practicing more selectivity when choosing board members. Corporations should seek out industry insiders who come to the board with better understanding of the risks associated with the industry*

at hand. Going forward, corporate boards will be expected not only to be independent in terms of their independence but also to act independently ... far from being backseat drivers. Instead, directors should act as advisers and function to complement management by anticipating blind spots, and offering advice based on their own professional experiences'

A strong argument for the case of board expertise is that those independent directors who do not possess the necessary expertise to evaluate the information presented by management are vulnerable to become dependent upon the representations of management for the information that is necessary to assess important strategic initiatives, risks, and decisions.

Hau, Johannes and Marcel (2011) research on the qualitative features of board independence found that industry experience of board members correlates positively with abnormal stock returns and negatively with earnings manipulation as measured by a small number of negative income restatements.

On the other hand, Andres, Romero-Merino, Santamaría, & Vallelado (2012) considers that the debatable results of the research regarding the relation between board independence and firms' performance need to be reappraised. Similarly, Crespi, Garcia-Cestona, and Salas (2002) argue that the assumption that appropriate industry-specific experience would strengthen boards' ability is not empirically supported.

H3: There is a positive significant relationship between Board financial expertise and firm performance.

3. METHODOLOGY

The design adopted for the study is cross-sectional research design. The design is well suited in examining the several sample units across time. The population of this study consists of all firms listed on the Nigerian Stock Exchange. The study used secondary data sourced from companies quoted on the Nigerian stock exchange. A total number of 50 companies with data span from 2008-2013 was selected across four (4) sectors namely; agricultural sector, conglomerates, construction and brewery. The Ordinary Least Squares Regression was adopted as the data estimation technique. Preliminary statistics such as the descriptive and correlation analysis was also conducted. The estimation is conducted on a sectorial and then full sample basis. The model is specified thus;

$$PAT_{it} = \eta_0 + \eta_1 BDSIZE_{it} + \eta_2 BDIND_{it} + \eta_3 BDFINX_{it} + \eta_4 CEODUA_{it} + \mu_{it}$$

$$ROE_{it} = \phi_0 + \phi_1 BDSIZE_{it} + \phi_2 BDIND_{it} + \phi_3 BDFINX_{it} + \phi_4 CEODUA_{it} + \mu_{it}$$

Where: PAT= Profit after tax
 ROE= Return on equity BDSIZE = Board size
 BDIND= Board Independence
 CEODUA= CEO Duality
 BDFINX= Board financial expertise
 $\Gamma_0 - \Gamma_4$ = slope coefficients
 $\phi_0 - \phi_1$ = slope coefficients
 i= ith firm
 t= time period

4. PRESENTATION AND ANALYSIS OF DATA

Table 1: Descriptive Statistics

	PAT	ROE	BDSIZE	BDIND	CEODUA	BDFINX
Mean	3093.88 6	0.55636 4	9.44090 9	1.31818 2	0.13636 4	7.03636 4
Median	428.000 0	0.21500 0	9.00000 0	1.00000 0	0.00000 0	7.00000 0
Maximum	57681.0 0	14.0000 0	20.0000 0	6.00000 0	1.00000 0	16.0000 0
Minimum	-32700	-1.24	5.00000 0	0.00000 0	0.00000 0	1.00000 0
Std. Dev.	8329.00 3	1.76027 0	3.01762 8	1.60724 3	0.34395 7	2.97148 5
Jarque-Bera	1838.34 7	14812.4 0	32.3425 5	44.1930 1	221.568 7	2.17664 6
Probability	0.00000 0	0.00000 0	0.00000 0	0.00000 0	0.00000 0	0.33678 1
Observations	220	220	220	220	220	220

Source: Researchers Compilation (2015)

Where: PAT= Profit after tax
 ROE= Return on equity BDSIZE = Board size
 BDIND= Board Independence
 CEODUA= CEO Duality
 BDFINX= Board financial expertise

Table 4.1 shows the descriptive statistics for the variables. As observed, PAT show the following statistics; Mean=3093.886, STD= 8329.003 which is high and suggest that PAT for the companies in the distribution do not exhibit considerable clustering around the average,

Max= 57681.00 and Min= -32700. For ROE, Mean= 0.556, STD= 1.7602 which is low and suggest that ROE for the companies in the distribution exhibit considerable clustering around the average, Max= 14.00 and Min =- 1.24. For BDSIZE, Mean ratio = 9.441, STD= 3.017, Max= 9 and Min= 5. For BDIND, Mean= 1.318, STD= 1.6072, Max= 6 and Min= 0. For CEODUA, Mean= 0.136 which indicates that about 13.6% of the sample companies do not exhibit the practice of CEO duality, STD= 0.343, Max= 1 and Min= 0. For BDFINX, Mean= 7.0363, STD= 2.971, Max= 16 and Min= 1.

Table 4.2 Pearson Correlation Result

	PAT	ROE	BDSIZE	BDIND	CEODUA	BDFINX
PAT	1					
ROE	0.3374	1				
BDSIZE	0.324	0.3406	1			
BDIND	0.28915	0.416782	0.683639	1		
CEODUA	-0.0463	-0.07007	-0.22097	-0.21926	1	
BDFINX	0.1924	0.176384	0.73099	0.438326	-0.12997	1

Source: Researchers Compilation (2015)

From table 4.2 above, the correlation coefficients of the variables are examined. However of particular interest to the study is the correlation between; profitability measures (ROA and PAT) and the other variables. As observed, PAT is positively correlated with BDSIZE ($r=0.324$), BDIND ($r=0.28915$), BDFINX($r= 0.192$) and negatively related to CEODUA ($r=-0.0463$). As also observed, ROE is positively correlated with BDSIZE ($r=0.3406$), BDIND ($r=0.4167$), BDFINX ($r= 0.176$) and negatively related to CEODUA ($r=-0.176$). We proceed to conduct the regression analysis as correlation analysis is not best suited for estimating causality between variables. However, the regression assumptions test is first conducted. The test to be conducted includes; the Jacque-bera test for normality, the Variance Inflation test for Multicollinearity, Autoregressive conditional heteroskedasticity test for Heteroskedasticity, the Breusch-Godfrey test for Serial Correlation, the Ramsey reset test for model specification. The results are presented below;

Table 4.3 Regression Assumptions Test

Normality test		
Variable	Jacque-bera statistics	Prob
PAT	1838.347	0.000000

ROE	14812.40	0.000000
BDSIZE	32.34255	0.000000
BDIND	44.19301	0.000000
CEODUA	221.5687	0.000000
BDFINX	2.176646	0.336781
Multicollinearity test		
Variable	Coefficient Variance	Centered VIF
BDSIZE	0.000140	2.315843
BDIND	0.005972	1.612001
CEODUA	0.000429	2.123828
BDEDU	4.35E-06	1.479244
Heteroskedasticity Test: Breusch-Pagan-Godfrey		
F-statistic = 4.383	Prob. F(8,5)	0.667
Obs*R-squared = 4.36	Prob. Chi-Square(8)	0.476
Breusch-Godfrey Serial Correlation LM Test:		
F-statistic = 92.674	Prob. F(2,3)	0.795
Obs*R-squared=78.236	Prob. Chi-Square(2)	0.371
Ramsey Reset Test		
t- statistics=1.577	Df= 4	0.451
f-statistics =2.489	Prob. F(1,4)	0.451

Source: Researchers Compilation (2015)

Table 4.3 shows the results for the regression assumptions test. To test for normality, we utilized the Jacque-bera statistics. This assesses the normality of the distribution of scores. In testing for multicollinearity, the variance inflation factor (VIF) test is conducted. The VIF shows how much of the variance of a coefficient estimate of a regressor has been inflated due to collinearity with the other regressors. Basically, VIFs above 10 are seen as a cause of concern (Landau and Everitt, 2003). As observed, none of the variables have VIF's values exceeding 10 and hence none gave serious

indication of multicollinearity. The Breusch-Pagan-Godfrey test for heteroskedasticity was performed on the residuals as a precaution. The results showed probabilities in excess of 0.05, which leads us to reject the presence of heteroskedasticity in the residuals. The Lagrange Multiplier (LM) test for higher order autocorrelation reveals that the hypotheses of zero autocorrelation in the residuals were not rejected. This was because the probabilities (Prob. F, Prob. Chi-Square) were greater than 0.05. The LM test did not therefore reveal serial correlation problems for the model. The performance of the Ramsey RESET test showed high probability values that were greater than 0.05, meaning that there was no significant evidence of miss-specification. We can then proceed to conduct the regression analysis

Table 4.4: Regression Result

Variable	Dependent Variable = PA'				
	Sectors				
	Full samp	Agric.	Conglom.	Constructio	Brewery
C	0.354* (0.637) {0.000}	1798.04 (0.000) {0.013}	-3739.410 (3035.513) {0.2323}	-3732.390 (8644.029) {0.669}	-8722.481* (2651.56) {0.001}
BDSIZE	0.075* (0.871) {0.000}	179.847 (169.37) {0.306}	290.460 (345.758) {0.410}	3660.798* (1673.550) {0.038}	440.496 (1.221) {0.224}
BDIND	0.007* (0.654) {0.000}	-361.67 (103.27) {0.004}	-1224.822 (421.617) {0.009}	-2973.007 (1775.708) {0.1106}	1559.43* (554.847) {0.006}
CEODUA	-0.354* (0.890) {0.000}	183.692 (209.59) {0.396}	290.412 (1890.59) {0.8795}	-11416.72* (4507.56) {0.018}	2540.56 (2665.81) {0.342}
BFINX	0.0111* (0.487) {0.021}	134.58 6 (147.23) {0.376)	562.404 (352.6568) {0.126}	-4714.486* (1650.432) {0.009}	804.29* (388.147) {0.040}
AR(1)			1.133 (0.235) {0.001}		0.566* (0.074) {0.000}
AR(2)			-0.3008 (0.232) {0.210}	-0.389 (0.184) {0.0455}	

R ²	0.812	0.743	0.649	0.372	0.579
ADJ R ²	0.754	0.670	0.544	0.246	0.562
F-Stat	12.908	10.145	6.188	2.961	4.071
P(f-stat)	0.000	0.000	0.0008	0.031	0.00
D.W	2.07	2.00	2.12	2.12	2.11
Mean dependent var	231.908	600.00	1296.566	4917.806	4010.180
S.D. of dependent var	190.066	645.622	2450.300	12484.24	7883.551
Dependent Variable = RO					
Variable	Sectors				
	Full samp	Agric.	Conglom	Construction	Brewery
C	0.907 (0.097) {0.000}	1.549 (0.771) {0.067}	-0.4579 (0.461) {0.3319}	3.6816 (1.978) {0.075}	-0.999 (0.652) {0.128}
BDSIZE	43.907 (0.110) {0.013}	-0.192 (0.021) {0.382}	-0.0192 (0.0885) {0.829}	-0.589 (0.353) {0.108}	0.166 (0.083) {0.049}
BDIND	6.098 (0.309) {0.000}	-0.011 (0.105) {0.914}	-0.187 (0.098) {0.069}	1.0268 (0.4071) {0.018}	0.0413 (0.135) {0.003}
CEODUA	-2.421 (0.259) {0.000}	0.341 (0.257) {0.209}	0.137 (0.318) {0.671}	-0.568 (0.940) {0.550}	0.982 (0.634) {0.125}
BDFINX	0.519 (0.186) {0.000}	0.0772 (0.176) {0.670}	0.126 (0.112) {0.274}	0.220 (0.652) {0.521}	-0.077 (0.093) {0.403}
AR(1)			0.2777 (1.134) {0.269}	-0.237 (0.194) {0.233}	0.721 (0.063) {0.000}
R ²	0.797	0.309	0.231	0.2132	0.680
ADJ R ²	0.690	0.020	0.056	0.0559	0.667
F-Stat	18.09	1.071	1.322	1.355	4.071
P(f-stat)	0.000	0.423	0.291	0.274	0.00

D.W	2.00	2.055	1.965	2.159	1.68
Mean dependent var	291.09	0.432	0.1500	0.621	0.7173
S.D. of dependent var	102.86	0.436	0.394	2.495	1.930

Table 4.4 above, shows the regression result which examines the effect of board attributes on financial performance. The estimation is conducted on a sectorial and then full sample basis. Using PAT as the profitability measure, the full sample estimation reveals that the R^2 is 0.812 which suggests that corporate governance explains about 81.2% of systematic variations in profitability with an adjusted value of 75.4. The F-stat (12.908) and p-value (0.00) indicates that the hypothesis of a significant linear relationship between the dependent and independent variables cannot be rejected at 5% level while the D.W statistics of 2.07 indicates that the presence of serial correlation in the residuals is unlikely. Commenting on the performance of the corporate governance variables, we observe that BDSIZE has positive effect (0.075) which is also statistically significant ($p=0.00$) at 5% level. BDIND has a positive (0.007) effect and also statistically significant at 5% ($p=0.000$). BGD appeared to have a negative (-0.007) impact and statistically significant at 5% ($p=0.004$). The effect of CEODUA appeared negative (-0.354) and statistically significant at 5% ($p=0.000$). BFINX appeared to have a positive (0.0111) impact and statistically significant at 5% ($p=0.021$). Using ROA as the measure for profitability, we observe that the R^2 is 79.1 with an adjusted value of 0.690. The F-stat (18.09) and p-value (0.00) indicates that the hypothesis of a significant linear relationship between the dependent and independent variables cannot be accepted at 5% level while the D.W statistics of 2.00 indicates that the presence of serial correlation in the residuals is unlikely. Commenting on the performance of the corporate governance variables, we observe that BDSIZE has positive effect (43.907) which is also statistically significant ($p=0.013$) at 5% level. BDIND has a positive (6.098) effect and also statistically significant at 5% ($p=0.000$). The effect of CEODUA appeared negative (-2.421) and statistically significant at 5% ($p=0.000$). BFINX appeared to have a positive (0.519) impact and statistically significant at 5% ($p=0.000$).

Moving into the sectorial analysis, we observe that for companies in the Agricultural sector, Using PAT as the profitability measure, the R^2 is 0.743 which suggests that corporate governance explains about 74.3 % of systematic variations in profitability with an adjusted value of 67.0%. The F-stat (10.145) and p-value (0.00) indicates that the hypothesis of a significant linear relationship between the dependent and independent variables cannot be rejected at 5% level while the D.W statistics of 2.00 indicates that the presence of serial correlation in the residuals is unlikely. Commenting on the performance of the corporate governance variables, we observe that only BDIND has a statistically significant effect on profitability at 5% ($p=0.000$) with a negative coefficient (-361.67). Using ROA as the measure for profitability, we observe that the R^2 is 30.9% with an adjusted value of 0.020. The F-stat (1.071) and p-value (0.423) indicates that the hypothesis of a significant linear relationship between the dependent and independent variables cannot be rejected at 5% level while the D.W statistics of 2.055 indicates that the presence of serial correlation in the residuals is unlikely. Commenting on the performance of the corporate governance variables, we observe that none of the variables appear to have any significant effect of ROA.

For companies in the Conglomerates sector, Using PAT as the profitability measure, the R^2 is 0.649 which suggests that corporate governance explains about 64.9% of systematic variations in profitability with an adjusted value of 54.4%. The F-stat (6.188) and p-value (0.00) indicates that the hypothesis of a significant linear relationship between the dependent and independent variables cannot be rejected at 5% level while the D.W statistics of 2.12 indicates that the presence of serial correlation in the residuals is unlikely. Commenting on the performance of the corporate governance variables, we observe that only BDIND has a statistically significant effect on profitability at 5% ($p=0.000$) with a negative coefficient (-361.67). Using ROA as the measure for profitability, we observe that the R^2 is 23.1% with an adjusted value of 0.056. The F-stat (1.322) and p-value (0.291) indicates that the hypothesis of a significant linear relationship between the dependent and independent variables cannot be accepted at 5% level while the D.W statistics of 1.96 indicates that the presence of serial correlation in the residuals is unlikely. Commenting on the performance of the corporate governance variables, we observe that none of the corporate governance variables appear to have a statistically significant effect on ROA.

For companies in the Construction sector, Using PAT as the profitability measure, the R^2 is 0.372 which suggests that corporate governance explains about 37.2% of systematic variations in profitability with an adjusted value of 24.6%. The F-stat (2.961) and p-value (0.031) indicates that the hypothesis of a significant linear relationship between the dependent and independent variables cannot be rejected at 5% level while the D.W statistics of 2.12 indicates that the presence of serial correlation in the residuals is unlikely. Commenting on the performance of the corporate governance variables, we observe that

BDSIZE has positive effect (3660.79) which is also statistically significant ($p=0.038$) at 5% level. The effect of CEODUA appeared negative (-11416.72) and statistically significant at 5% ($p=0.018$). BFINX appeared to have a negative (-0.389) impact and statistically significant at 5% ($p=0.0455$). Using ROA as the measure for profitability, we observe that the R^2 is 21.3% with an adjusted value of 0.0559. The F-stat (1.355) and p-value (0.274) indicates that the hypothesis of a significant linear relationship between the dependent and independent variables cannot be accepted at 5% level while the D.W statistics of 2.159 indicates that the presence of serial correlation in the residuals is unlikely. Commenting on the performance of the corporate governance variables, we observe that only BDIND appears to have a statistically significant effect on ROA.

For companies in the Brewery sector, Using PAT as the profitability measure, the R^2 is 0.579 which suggests that corporate governance explains about 57.9% of systematic variations in profitability with an adjusted value of 56.2%. The F-stat (4.071) and p-value (0.000) indicates that the hypothesis of a significant linear relationship between the dependent and independent variables cannot be rejected at 5% level while the D.W statistics of 2.11 indicates that the presence of serial correlation in the residuals is unlikely. Commenting on the performance of the corporate governance variables, we observe that BDIND has a positive (1559.43) effect and also statistically significant at 5% ($p=0.006$). BFINX appeared to have a positive (804.29) impact and statistically significant at 5% ($p=0.040$). BFINX appeared to have a positive (0.566) impact and statistically significant at 5% ($p=0.040$). Using ROA as the measure for profitability, we observe that the R^2 is 68% with an adjusted value of 67%. The F-stat (4.071) and p-value (0.00) indicates that the hypothesis of a significant linear relationship between the dependent and independent variables cannot be rejected at 5% level while the D.W statistics of 2.12

indicates that the presence of serial correlation in the residuals is unlikely. Commenting on the performance of the corporate governance variables, we observe that BDSIZE has positive effect (0.166) which is also statistically significant ($p=0.049$) at 5% level. The effect of BDIND appeared positive (0.0413) and statistically significant at 5% ($p=0.003$).

4.3 DISCUSSION OF RESULT AND HYPOTHESES TESTING

Using PAT as the profitability measure, the full sample estimation reveals that BDSIZE has positive effect (0.075) which is also statistically significant ($p=0.00$) at 5% level. Using ROA as the measure for profitability, BDSIZE has positive effect (43.907) which is also statistically significant ($p=0.013$) at 5% level. The effect of Board size appears to have the expected relation hence we accept the hypothesis of a positive significant relationship between Board size and financial performance. However, the determination of what the optimal board size should be is still without unanimity. Nevertheless, our study re-affirms that board size is a significant factor in the determination of firm's financial performance. The finding is in tandem with Kyereboah-Coleman (2007) revealed that boards enhance firm financial performance, Bathula (2008) affirmed that board size positively affects firm performance (ROA). Kajola (2008) found significant relationship between board size and ROE. Babatunde and Olaniran (2009) established a significant relationship between board size and ROA. Chienjien (2010) and Uadiale (2010) asserted that board size has a strong positive association with corporate financial performance. Ibrahim, Rehman and Raof (2010) reported that the impact of board size on firm performance (ROE) is significant. In contrast with our findings, Bathula (2008) found no significant relationship between board size and profit margin (PM). Ibrahim, et al (2010) reported that board size has no significant impact on return on asset (ROA).

Using PAT as proxy for financial performance, BDIND has a positive (0.007) effect though not statistically significant at 5% ($p=0.721$). Using ROA, BDIND has a positive (6.098) effect and also not statistically significant at 5% ($p=0.310$). The statistically insignificant effect of Board Independence seems to be at variance with our theoretical expectation, it nevertheless suggest that the number of outside directors as a proportion of total board membership though a necessary condition, may not be sufficient condition for financial performance. Hence we reject the hypothesis of a positive significant relationship between Board independence and financial performance. A closely related issue for consideration is with regards to the

extent of participation of non-executive directors and in what committees are they dominant. The question of whether having higher number of non-executive directors than executive directors on board enhances firm financial performance has continued to be debateable and empirical evidence from researchers has often been associated with mixed results. In tandem with our findings, Mehran and Schaefer (2004) cited in Sanda, et al (2011) reported no significant relationship between the fraction of outside directors serving on a committee and the performance of the firm. This is also supported by Sanda et al (2005) who found no evidence to support the idea that boards with a higher proportion of outside directors perform better than other firms in terms of ROA and ROE. Kajola (2008) observed no significant relationship between board independence and firm performance.

BFINX appeared to have a positive (0.0111) impact and statistically significant at 5% ($p=0.021$). Using ROA as the measure for profitability, BFINX appeared to have a positive (0.519) impact and statistically significant at 5% ($p=0.000$). The result implies that the higher the number of board members with financial education, the higher the financial performance of the firm. Hence we accept the hypothesis of a positive significant relationship between BFINX and financial performance.

5. CONCLUSION

Corporate governance has dominated policy agendas in developed market economies for more than a decade. The relationship between corporate governance and performance is based on the principal-agent approach. The agency relationship is defined as a contract which one or more persons (the principal(s) engage another person (the agent) to perform some service on their behalf. Corporate governance can be conceived as a set of arrangements internal to the corporation that defines the relationships between managers and shareholders. The shareholders may be public or private, concentrated or dispersed. Furthermore, these arrangements may be codified in company law, securities law, listing requirements, and the like or negotiated among the key players in governing documents of the corporation. However, in spite of the renewed interests in issues of corporate governance, relevant empirical studies are still few and far in-between in Nigeria. This has limited the depth of our understanding of corporate governance and its relationship with corporate performance. The study finds a positive significant relationship between Board size and financial performance. The study also finds a positive though insignificant

relationship between Board independence and financial performance. The effect of CEODUA appeared negative and statistically significant while BFINX appeared to have a positive significant relationship between BFINX and financial performance. The recommendation is that there is a need to strictly enforce the Nigerian Securities and Exchange Commission (SEC) "code of corporate governance best practices". The code addresses such issues as the roles of the board and the management, Shareholders rights and privileges and the role of the Audit Committee. In addition, the study recommends that there may be a need to carefully consider firm specific factors in determining the corporate governance regulation as a "one size fits all" approach may not be optimal. This is because the literature indicates mixed evidence for corporate governance and firm performance when specific factors as firm size, complexity, industry of operation are controlled for.

References

- Abu-Tapanjeh, A. (2006). Good corporate governance mechanism and firms' operating and financial performance. Insight from the perspective of Jordan industrial companies. *Journal of King Saud University*, 19(2), 101-121.
- Adusei, M. (2011) Board structure and bank performance in Ghana. *Journal of Money, Investment & Banking*, 19, 72-84.
- Al-Hawary, S. (2011). The Effect of banks governance on banking performance of the Jordanian commercial banks: tobin's q model "an applied study". *International Research Journal of Finance and Economics*, 71, 35-45.
- Aljifri, K. & Moustafa, M. (2007). The impact of corporate governance mechanisms on the performance of uae firms: an empirical analysis. *Journal of Economic & Administrative Sciences*, 23 (2), 71-93.
- Al-Manaseer, M.F., Al-Hindawi, R.M., Al-Dahiyat, M.A., & Sartawi, I.I. (2012). The impact of corporate governance on the performance of Jordanian banks. *European Journal of Scientific Research*, 67(3), 349-359.

- Amran, N.A. (2011). Corporate governance mechanisms and company performance: evidence from Malaysian companies. *International Review Of Business Research Papers*, 7(6), 101-114.
- Andres, P., Vallelado, E. (2008). Corporate governance in banking: the role of the board of directors. *Journal of Banking & Finance*, 32, 2570-2580
- Babatunde, M.A. & Olaniran, O. (2009). The effects of internal and external mechanism on governance and performance of corporate firms in Nigeria. *Corporate Ownership & Control*, 7 (2), 330-344.
- Bathula, H. (2008). Board Characteristics and Firm Performance: Evidence from New Zealand. Ph.D Dissertation, AUT University. Available at: http://aut.researchgateway.ac.nz/bitstream/handle/10292/376/BathulaH_a.pdf?se [Accessed 12 January 2012].
- Berle, A.A. & Means, G. C. (1932). *The modern corporation and private property*. Harcourt, Brace and World, Inc. Reprinted 1991 by Transaction Publishers, New Brunswick, New Jersey, USA.
- Chienjien, F. (2010). Corporate governance in the Nigerian financial sector: an ethical analysis of the 2009 intervention and operators behavior. Retrieved 12 April 2015 from www.ssrn.com
- Coles, J.W. & Hesterly, W.S. (2000). Independence of the chairman and board composition: Firm choices and shareholder value. *Journal of Management*, 26(2), 195-214.
- Crespi, R., Garcia-Cestona, M. A. & Salas, V. (2002). Governance mechanisms in Spanish financial intermediaries. *Universitat Autònoma de Barcelona*- 28-0
- Daily, C.M., Dalton, D.R. & Cannella, A.A. (2003). 'Corporate governance: Decades of dialogue and data.' *Academy of Management Review*, 28(3), 371-382.
- Dalton, D.R., Daily, C.M., Ellstrand, A.E. & Johnson, J.L. (1998). Meta-analytic reviews of board composition, leadership structure, and

- financial performance.' *Strategic Management Journal*, **19**(3), 269-290.
- Forbes, D.P. & Milliken, F.J. (1999). Cognition and corporate governance: Understanding boards of directors as strategic decision-making groups. *Academy of Management Review*, **24**(3), 489-505.
- Golden, B.R. & Zajac, E.J. (2001). 'When will boards influence strategy? Inclination X power strategic change.' *Strategic Management Journal*, **22**(12), 1087-1112.
- Hau, H., Johannes, S. & Marcel, T. (2011). Bank governance and the crisis: did board (in) competence matter for bank performance during the recent crisis? *The European Financial Review*, February - March 2011, 38- 41
- Ibrahim, Q., Rehman, R. & Raoof, A. (2010). Role of corporate governance in firm performance: A comparative study between chemical and pharmaceutical sector in Pakistan. *International Research Journal of Finance and Economics*, 50, 8-16
- Johnson, J.L., Daily, C.M. & Ellstrand, A.E. (1996). Boards of directors: A review and research agenda. *Journal of Management*, **22**, 409-438.
- Kajola, S.O., (2008). Corporate governance and firm performance: The case of Nigerian listed firms. *European Journal of Economics, Finance Administrative Science*
- Kyereboah-Coleman, A. (2007). Corporate governance and firm performance in Africa: a dynamic panel data analysis. Asian Institute of Corporate Governance, Turkey. Available at: [http://www.ifc.org/ifcext/cgf.nsf/AttachmentsByTitle/PS2.3/\\$FILE/Kyreboah-](http://www.ifc.org/ifcext/cgf.nsf/AttachmentsByTitle/PS2.3/$FILE/Kyreboah-)
- Sanda, A., Mikailu, A. & Garba, T. (2005). Corporate governance mechanisms and firm financial performance in Nigeria: African Economic Research Consortium, Research Paper, 149, Kenya regal press.

Sundaramurthy, C. & Lewis, M. (2003).Control and collaboration: Paradoxes of governance.S *Academy of Management Review*, **28**(3), 397-415.

Uadiale, O. M. (2010) .The impact of board structure on corporate financial performance in Nigeria. *International Journal of Business and Management*, 5 (10), 15-37.

**CORPORATE BOARD STRUCTURE AND EARNINGS
MANAGEMENT OF LISTED CEMENT COMPANIES IN NIGERIA
- Sama'ila, I. A. & Zaharaddeen, A.**

ishaqismail005@yahoo.com, iaismaila.acc@buk.edu.ng

GSM: +234 8039643788

Department of Accounting, Bayero University, Kano-Nigeria.

And

Zaharaddeen Abdullahi B.Sc, M.Sc

deen027@yahoo.com

GSM: +234 8033831857

Department of Accounting, Bayero University, Kano-Nigeria.

CORPORATE BOARD STRUCTURE AND EARNINGS MANAGEMENT OF LISTED CEMENT COMPANIES IN NIGERIA

ABSTRACT

This study examines the impact of board structure on earnings management of listed cement companies in Nigeria for ten years (2004-2013). The data for the study were extracted from the annual reports and accounts of the sampled firms for the study period. Descriptive statistics, Pearson correlation and regression technique were used to analysed the data with the aid of Stata Version 12. A panel data regression technique was employed since the data has both time series and cross sectional attributes. It was found that board size has a positive and significant effect on the earnings management of the sampled firms while board independence has negative and significant effect on earnings management. However, female directors on the board and leverage have a negative but insignificant effect on the earnings management of firms in the Nigerian cement companies. Furthermore, the effect of directors' independence on earnings management of firms as showed by empirical evidence provides a plausible explanation. This has significant policy implications for the composition of the board of directors. The analysis points to the attractiveness of pluralistic board appointments, composed of independent members, corporate executives, and other parties with specific knowledge of the firms' business will go a long way in improving the capacity and capability of monitoring management to decline from opportunistic behaviour to benefit themselves at the detriment of the firm. The study recommends that regulatory authorities like SEC, NSE and FRCN in collaboration with shareholders should ensures that the board comprises of an optimum of nine (9) members and also set up a committee to verify the appointment of non-executive directors based on expertise, experience and reputation as this will strengthen board independence to further safeguard and add more credibility and reliability on the quality of the financial reports of Nigerian cement companies.

Keywords: Earnings Management, Board size, Independent, Female representative & Leverage

1.0 Introduction

The divorce of ownership from management necessitates the need for managers to report the results of their stewardship to the owners. This is done via the preparation and presentation of financial statements. However, the potential conflict of interest between principal and agent prompts agent to use the flexibility and loopholes provided by accounting principles to manage income opportunistically (earnings management), thereby creating distortions in the reported earnings which in turns, affect the integrity and credibility of financial information. Healy and Wahlen (1999) defined Earnings Management (EM) as the use of judgments in financial reporting and in structuring transactions to alter financial reports to either mislead some stakeholders about the underlying economic performance of the company or to influence contractual outcomes that depend on reported accounting numbers. They documented that, managers mainly manipulate earnings for four kinds of incentives: external contract incentives, management compensation contract incentives, regulatory motivations and capital market motivations. The ability of managers to opportunistically manage reported earnings can be constrained by effective board which is an essential component of Corporate Governance (CG) (Klein, 2000b; Chtourou, Bedard & Courteau, 2001; Liu & Lu, 2007; Samaila, 2014)

The Organization for Economic Corporation and Development (OECD, 1999) defined CG as a system by which business corporations are directed and controlled. In fact, Rahman and Ali (2006) opined that, lack of strong board is the genesis for the failure of many businesses. This was evidenced in the case of Enron, HealthSouth, Tyco, Adelphia and WorldCom, African Petroleum plc, Spring Bank, Wema bank, Savanna bank, Gulf bank, Benue cement and Cadbury plc to mention but few.

For the board to be effective in monitoring and controlling management as well as curtailing earnings management, the board should be of an optimum size, independent and hold regular meetings. A competent board also requires the need for power separation and gender balance to further enhance the credibility of financial reporting. A significant number of studies

among researchers, practitioners and academicians have examined the roles of board in constraining earnings management. At the international arena, Dechow, Sloan and Sweeney (1995), Klein (2002a), Peasnell, Pope and Young (2005), Gulzar and Wang (2011), Chekili (2012) and Waweru and Riro (2013), examined the relationship between board structure and earnings management. Board size, CEO duality, number of meetings, financial expertise, independence and the proportion of female director in board were employed as proxies for CG; while Discretionary Accrual was used to measure earnings management.

In Nigeria, there is paucity of studies that examined the roles of board on earnings management. Notably, Tijjani and Dabor (2010), Oladipupo and Okafor (2011) and Uadiale (2012). However, none of the studies to the best of the researcher's knowledge was conducted on cement companies despite their strategic position toward the development of Nigerian economy. The recent collapse of the Benue cement company in 2010 due to tax evasion of about 190 million naira (Wikipedia, 2014) signifies the presences of manipulative practices and cast further doubt on the roles of board in curtailing earnings management. In addition, none of the studies employed discretionary accrual to measure earnings management. This paper therefore, examines the impact of board structure (board size, independence and female representation) on the earnings management practices of cement companies in Nigeria. To accomplish this, the paper is divided into five sections namely; introduction, literature review, methodology, results and discussions, and finally conclusion and recommendations.

2.0 Literature Review

This section reviews relevant empirical studies on the impact of board structure (board independence, size and female representatives in board) on earnings management.

2.1 The concept of Earnings Management

Scholars like Akers, Giacomino and Bellovary, Chen and Jean; and Man, explained earnings management based on the prevailing economic conditions in the environment in which they find themselves. Akers *et al.* (2007) defined earnings management as attempts by management to influence or manipulate reported earnings by using specific accounting methods (or changing methods), recognizing one-time non-recurring items, deferring or accelerating expense or revenue transactions, or using other methods designed to influence short-term earnings. Chen & Jean (2010) argue that earnings management misleads the users of financial statements by providing them with false information about a firm's true operating performance.

Also, Man (2012) defined earnings management as the choice by managers of accounting policies, or other actions including voluntary earnings forecasting, voluntary disclosure, and estimation of accruals, to affect earnings intentionally. Earnings management on the financial statements may undermine the credibility of financial statements which are very useful information for stakeholders in a well-functioning capital markets. Most studies on earnings management literature have focused on two types of general earnings management: accrual management and the manipulation of real economic activities. For the accruals management, the firm can use provision for credit losses, warranty cost, inventory values, and timing and amount of unusual items to manipulate earnings. Another type is to use real variables which may be costly to affect the firm's long term interest. Graham, Harvey and Rajgopal (2005) argue that management would like to use real variables to manage the earnings.

From the above, earnings management involve the choice of accounting policies employed by managers to achieve their self interest by misleading stakeholders via the presentation of distorted financial statement.

There are many approaches in detecting earnings management but the Accrual-Based Models are the most popular approaches. Basically, the balance sheet and cash flow approaches are the two ways for computing total accruals. The balance sheet approach was used by Healey (1985), Jones (1991), Gulzar, *et al.* (2011) and Gonzale, *et al.* (2013) to compute total accrual. The second approach is the Cash flows approach as put forward by Liu *et al.* (2007) and Mohammed and Pourtazeem (2012). While there is consensus in the literature on the computation of total accrual, a lot of models have been developed by scholars for the computation of the discretionary component of total which is the actual EM. The most popular of which are Healy model (1985), DeAngelo model (1986), Jones model (1991), Modified Jones model (1995) and performance match discretionary accrual (2005) to mention but few.

2.2 Board Attributes and Earnings Management

Board attribute are the characteristics or features which a board should possess that are essential in reducing earnings management. According to Fernandez, Gomez and Fernandez (1997), most of the previous CG literatures discuss mainly two characteristics or variables that influence the monitoring capabilities of Boards: their independence and size. Gonzale *et al.* (2013) opined that board activity and the CEO duality or concentrations of power are other attributes of a board that influenced its decisions. However, board sex ratio is another important attribute of CG (Adams & Ferreira 2009). Empirical works have produced inconsistent results about the effect of board attributes on the earnings management of firms.

The number of members on the board of an entity is an important determinant of the extent to which earnings can be manipulated. Literature documented mixed evidence on the association between board size and effective monitoring. On one hand, Jensen, (1993) and Eisenberg, Sundgren and Wells (1998) argue that small board size of four to six members might be more effective since they are able to make effective communication and well timely strategic decisions. Santiago and Brown (2009) took a sample of 97 companies in Brazil, Chile, and Mexico and found a positive relation between the size of the Board and EM.

On the other hand, larger board is expected to be less effective as the monitoring responsibility will be diffused among many directors (Vafeas, 2000). Chtourou *et al.* (2001); Xie, Davidson and Dadalt. (2003); Peasnell, *et al.* (2005) and Cornett, Marcus, Saunders and Tehranian (2008), provide evidence that board size is negatively associated with the levels of earnings management. Chin and Kim (2006) using a sample of 313 firms from Hong Kong, found a negative relation between the size of the board and EM, concluding that with a larger board, fewer are the manipulative practices made by the management of companies. Zahra and Pearce (1989) and Dalton, Daily, Johnson and Ellstrand (1999) found out that larger boards assume a better supervision of the management team, higher quality of corporate decisions, better monitoring since they have better environmental links and more expertise. Davila and Watkins (2009) in Mexico found that if the size of the board is very small, the monitoring of the management team is smaller too, so they tend towards greater discretion in receiving higher remuneration, a greater chance of EM and are more prone to information asymmetry.

The empirical findings relating to the mitigating role of board size on earnings management are quite vague, with one group arguing that larger boards perform a more thorough control of managers' decisions, while on the contrary other studies argue that smaller corporate boards are more efficient monitors than large boards because they have a higher level of membership coordination, communication efficiency and a lower incidence of intense free-rider problem.

Similarly, it has often been recommended that the number of external members on the board of directors be greater than the owners, for there to be more oversight of management and to maximize the value of the organization (Zattoni & Cuomo 2010). This suggests that the degree of board independence is directly related to the quality of information that firms issues (Cheng & Courtenay 2006). Fama and Jensen (1983), Dechow & Dichev (2002) and Peasnell *et al.* (2000) documented that independent directors do not have self-interest such as executive compensation and misappropriation of assets, pressure from shareholders to meet or beat expectation of firm performance but the need to maintain personal reputation with the public. Dechow *et al.* (1995) argued that firms with large extent of earnings management are more likely board controlled by insiders rather than outsiders. Beasley (1996), documented that the inclusion of large numbers of outside directors on the board can reduce the likelihood of earnings management.

Furthermore, several studies provide empirical evidence relating to the role of external directors on the constriction of EM, documenting that a higher proportion of external directors, will mean greater and better quality of financial information issued by firms, so reducing the chances of EM (Xie *et al.* 2003; Davidson, Goodwin and Kent. 2005; Bradbury, Mark and Tan. 2006; Jaggi, Leung and Gul 2009). Marnet (2008) argue that independent boards contribute towards the integrity of financial statements through the control of managerial conflict of interests.

However, Klein, (2002); Bar-Yosef & Prencipe, (2009); and Randoy & Jenssen, (2004) documented that board independence is a weak earnings management constraint. Board quality as stated by Sarkar, Sarkar and Sen (2008) is more effective than board independence in constraining earnings management. Peasnell, *et al* (2005), document that for firms with higher proportion of non-executive directors, there are more likely increase in discretionary accrual to avoid earnings loss.

From the aforementioned studies, most of the results provide evidence of the mitigating role of board independence on the aggressive earnings management behaviour by firm managers. Therefore, independent directors on the board of an entity are more likely to mitigate EM

Another important board attribute is female representation. Females are participating more in corporate boards. Recently, researchers have provided more evidences of female participation in board (Hambrick, Nadler and Tushman 1998). Klenke (2002) proposed that the desires of female leaders and their efforts can built a culture of trust within firms using transformational strategies including visioning, impression management for organizational and individual good, and empowering members of the team. Hence, female leaders are more likely to build trust leadership style.

In the documented literature, Adams, *et al.* (2009) uncovered that female directors are more likely to have board diligence and demand greater accountability for managers' performance. Furthermore, female directors can think more independently compared with male directors and also effectively monitor chief executive officer behavior (Carter, Simkins and Simpson 2003). Adams, Gray and Nowland, (2010) argues that female directors can think more likely independently. Firms with more female in the board can have better earnings quality and lower earnings management as independent thinking is critical for checking the opportunistic activities and provide better quality of financial information. Further, Powell and Ansic (1997) provide evidence that females are less risk seeking (risk averse) in their decision making than males. Sunden and Surette, (1998) also found similar result. Therefore, female directors would not allow earnings manipulation leading them to face ligation risk and influence their reputation. Fondas and Sassalos (2000) argued that heterogeneous boards are more efficient than homogenous boards. The presence of female director in the board is associated with improved financial performance (Carter *et al.* 2003). They argued that, bringing women in the board decisions, may improve decision-making of the board. Bin, *et al.* (2011) argue that female directors can improve board governance including monitoring CEO, improving board attendance and better communication, which is more likely

to improve earnings quality. Therefore, female representation on board can actually reduce the extent of earnings management.

However, some studies suggest that firm performance has no significant relationship with board gender diversity. Watson (2002) found no significant differences between male- and female-controlled firms. Rose (2007) noted that there is no significant association between female board representation and firm performance. Adams *et al.*, (2009) and Emilia & Sami (2010) also found no relationship between earnings management and the gender of the firm's CEO.

From the literature, a mixed result is observed as some studies documented the need for female representation on board while few studies found no significant relationship between female representation and earnings management. The nature of female been risk averse, their communications skills and the need for gender diversity may curtail earnings management even though the number of female expected on the board is not specified.

3.0 Methodology

For the purpose of this study, descriptive research design was used. The study has its population as all the four (4) cement companies that are quoted on the first-tier market of the Nigeria Stock Exchange as at 31st December 2013. These are Lafarge Wapco Plc, Ashaka Cement Plc, Cement Company of Northern Nigeria Plc and Dangote Cement Plc. For any company to be included in the working population, it must have been listed on the NSE, on or before 31 December, 2003. Secondly, it must have been quoted without being delisted between 2004 and 2013. This criterion is established with a view to ensuring that the cement companies have their published financial statement for the period covered by this study. As a result of this filter the number of cement companies reduces to three. Dangote Cement Plc was listed on the floor of the Nigeria Stock Exchange in the year 2010, as such it lacks the requisite annual reports that are required to meet up with the scope of the study. The whole working population was taken as sample for the study.

The variables of the study consist of the dependent and explanatory variables. The dependent variable is the earnings management (EM) among firms in the Nigeria cement companies. To determine the EM, the study adopted the modified version of Jones model (1991) proposed by Dechow *et al.* (1995) which has been used in other studies like Teoh, Welch and Wong, (1998) and Xie *et al.* (2003) to determine the discretionary accruals. Following Dechow *et al.* (1995), the total accrual component of earnings is given by:

$$TACC_{it} = NI_{it} - CFFO_{it} \dots \dots \dots (1)$$

Where

TACC_{it} = total accruals for firm i in year t, which is the different between cash flows

from operation and net income before extra-ordinary item, interest and tax

NI_{it} = net income for firm i in year t,

CFFO_{it} = operating cash flow for firm i in year t.

The parameters for calculation of non-discretionary accruals (NDA) are estimated by using the following equation:

$$\frac{TACC_{it}}{A_{it-1}} = \alpha \left(\frac{1}{A_{it-1}} \right) + \beta_1 \left(\frac{\Delta REV_{it}}{A_{it-1}} \right) + \beta_2 \left(\frac{PPE_{it}}{A_{it-1}} \right) + \varepsilon_{it} \dots \dots \dots 2$$

Where,

TACC_{it} = total accruals for firm i in year t,

A_{it-1} = total assets for firm i in year t-1,

ΔREV_{it} = change in net revenue for firm i in year t,

PPE_{it} = property, plant and equipment for firm i in year t,

$\alpha \beta_1 \beta_2$ = coefficient parameters,

ε_{it} = error term for firm i in year t.

The NDA are calculated using the estimated parameters obtained from equation (2):

$$\frac{NDA_{it}}{A_{it-1}} = \hat{\alpha} \left(\frac{1}{A_{it-1}} \right) + \hat{\beta}_1 \left(\frac{\Delta REV_{it} - \Delta AR_{it}}{A_{it-1}} \right) + \hat{\beta}_2 \left(\frac{PPE_{it}}{A_{it-1}} \right) \dots \dots \dots 3$$

Where,

ΔAR_{it} = change in accounts receivable for firm i in year t,

$\hat{\beta}_1 \hat{\beta}_2 \hat{\alpha}$ = coefficient parameters estimates

Change in accounts receivable is not included in estimating the parameters but is included in calculating non-discretionary accruals. Similarly, in order to control heteroscedasticity, all variables are lagged by total asset (Teoh *et al.*, 1998, Ashbaugh, Lafond and Mayhew, 2003, Kam, 2006, Gulzar *et al.*, 2011, Gonzalez *et al.*, 2012, Alves, 2012).

Finally, DAC_{it} are calculated as the difference between TA and NDA

$$DCA_{it} = \frac{TACC_{it}}{TA_{it-1}} - NDCA_{it} \dots \dots \dots 4$$

The explanatory variables include the independent variables and control variables.

Board Structure (BS) is the independent variables. The measurement of these variables which is consistent with Chtourou *et al.* (2001); Klein (2002); Kam (2006); Hamid (2008); Tijjani *et al.* (2010); Gulzar *et al.* (2011); Gonzalez *et al.* (2012) and Alves (2012) is explained below.

Board Independence (BI) is measured by dividing the number of outside or non executive directors by the aggregate number of directors. Board Size (BS) is measured as the total number of board members on the board of the sampled firms. Number of Female (WD) in the board is the proportion of female directors to total directors.

The control variables included in the model is Leverage (LEV) measured as the ratio of total debt to total assets. Previous studies documented that managers of highly leveraged firms have strong incentives to use income increasing accruals to loosen the contractual debt-constraints (DeFond & Jiambalvo 1994 and Ali, Chen and Radhakrishnan 2008). Nevertheless, highly indebted firms may be less able to practice earnings management because they are under close scrutiny of lenders. Park and Shin, (2004) and Yang and Krishnan (2008) find a negative relationship between leverage and earnings management.

Data was analyzed using descriptive statistics, correlation and regression, which is in line with the work of Chtourou *et al.* (2001); Klein (2002); Kam (2006); Hamid (2008); Hutchinson (2008); Tijjani *et al.* (2010); Gulzar *et al.* (2011); Gonzalez *et al.* (2012) and Alves (2012) .

Based on the variables, the empirical results are thus based on the following regression model;

$$EM = a_0 + a_1 BS_{it} + BI_{it} a_2 + a_3 WD_{it} + a_4 LEV_{it} + e_{it}$$

Where:

EM = Earnings management

BS = Board Size

BI = Board Independent

WD = Female Director on the board

LEV = Leverage

a_0 = Parameters to be estimated (is the average amount the dependent variable increases when the independent increases by one unit and other independents are held constant).

e = an error term

a_1 - a_5 = partial derivatives or the gradient of the independent variable.

4.0 RESULTS AND DISCUSSION

This section presents the analysis and interpretation of the data generated from the annual report and accounts of the Nigerian cement companies. The OLS regression result was also explained in this section.

Table 1: Descriptive & Correlation Matrix of Dependent and Explanatory Variables

Variable	Mean	Std Dev	Min	Max	EM	BS	BI	WD	LEV	VIF
EM	-0.15	0.19	-0.62	0.17	1.0000					
BS	11.47	1.61	9	13	0.7635	1.0000				1.42
BI	0.78	0.12	0.39	0.92	- 0.5503	- 0.5170	1.0000			1.60
WD	0.70	0.04	0	0.15	- 0.0091	- 0.0780	0.2735	1.0000		1.19
LEV	0.67	0.74	0.27	4.44	- 0.0393	- 0.0166	- 0.2893	- 0.3562	1.0000	1.24

Source: Generated by the Author using the data extracted from the annual and accounts of Nigerian cement companies

Table 1 shows the descriptive statistics of the dependent and explanatory variables of the study. The mean of earnings management (EM) for the sampled Nigeria cement firms is -0.15 which suggest low degree of manipulative practices among the sampled firms during the study period. The standard deviation of 0.19 indicate that the magnitude of EM among the sampled firms varies with the least and highest been -0.62 and 0.17 respectively.

The board of the sampled firms comprises of an average of 12 directors as indicated by the mean. The standard deviation is 1.61. The least and highest value are 9 and 13 directors. The board of the sampled firms comprises of an average of 78% non-executive directors as indicated by the mean. The standard deviation is 0.12. The least and highest value are 38% and 92% degree of BI during the study period. The board sex ratio of the Nigeria cement firms shows that only **7%** of the board members of Nigerian cement companies are female while 93% are male. The standard deviation is 0.43. The board of Ashaka has female representation

throughout the study period while Lafarge Wapco and Cement Company of Northern Nigeria (CCNN) have female directors from the year 2007. Finally, leverage (LEV) has a mean of 0.67 and a standard deviation of 0.73. The least and largest degree of LEV are 0.27 and 4.44 respectively.

Similarly, the result of the correlation matrix as shown on Table 1 indicates that the coefficient of the dependent and explanatory variables is 1.000 along the primary diagonal. This is so because each variable has a perfect positive linear relationship with itself. The correlation coefficient for board size (BS) and earnings management (EM) is 0.76. This implies that BS and EM are strongly and positively correlated. The correlation coefficient for board independence (BI) and earnings management (EM) is -0.55. This implies that BI and EM are strongly and negatively correlated. The proportion of female representatives (WD) on the board of Nigerian cement companies are weakly and negatively correlated with EM as shown by the correlation coefficient of -0.009. This is due to the fact that the number of WD on the board of the sampled firms is insignificant (7%) compared to number of male directors (93%). In the same vein, the correlation coefficient of LEV and EM is -0.04. This result implied that LEV and EM are weakly and negatively correlated throughout the study period for all the sampled Nigeria cement companies.

The variance inflation factor (VIF) for all the explanatory variables ranges from 1.19 to 1.60 as shown on Table 1. This indicates the absence of collinearity or multicollinearity among the explanatory variables as VIF of 5.00 is still accepted as proof of absence of multicollinearity (Muhammad, 2009 and Samaila, 2014).

Table 2: Regression Result

Variables	Coefficient	Std error	T	P>/t/
CONSTANT	-0.6775	0.3352	-2.02	0.054
BS	0.0727	0.1674	4.34	0.000***
BI	-0.4115	0.2332	-1.76	0.09*
WD	-0.3790	0.5774	-0.66	0.52
LEV	-0.1932	0.3433	-0.56	0.58
R-square	0.6315			
Adj R-squared	0.5726			
F-statistics	10.71			
Prob>F	0.0000			

Source: Generated from the annual reports and accounts of Nigerian companies

*****, * indicate 1% , 10% Significant level**

Table 2, present the OLS result for the dependent and explanatory variables. The probability of F-statistics is 10.71 with a P-value of 0.0000. This suggests that the model is suitable for the study as the value is less than 1%. R^2 of 0.63 indicate that 63% of the variation in the dependent variable (EM) is jointly explained by the changes in the

explanatory variable; BS, BI, WD, and LEV. This position is confirmed by Adj R^2 of 0.57 which signifies that after adjusting for error term, 57% of the changes in EM of the sampled firms are jointly explained by the changes in BS, BI, WD, and LEV.

In an attempt to improve the validity of all statistical inference of variables for this study, heteroscedasticity test was conducted. The result of this test reveals the presence of homoscedasticity as the probability of the chi-square is 0.15 which is higher than 10%.

The t- value of 4.34 of the regression results indicates that BS has a positive and significant impact at 1% on the EM of the Nigerian cement companies. The implication of this is that an increase in the size of board of sampled firms other variables held constant increases earnings management in the Nigerian cement companies. This finding is confirmed by Vefeev, 2000; and Dimitropoulos, 2012. However, the finding of this study contradict the result of Jensen, 1993 and Rahman, *et al.* 2006; who documented that small board size of four to six members might be more effective since they are able to make effective communication and well timely strategic decisions.

Similarly, the t- value of -1.76 indicates that BI has a negative and significant impact on the EM of the Nigerian cement companies. The implication of this is that an increase in the degree of board independence other variables held constant, decreases earnings management in the Nigerian cement companies. This finding is confirmed by Dechow, Sloan & Sweeney (1996) who documented that the inclusion of large outsider directors in the board of an entity reduces the likely hood of EM. This is also consistent with the result of Chen, Elder & Hsieh (2007), Chekili (2012) and Gonzalez & Garcismeca. (2013) who documented that BI have a negative relationship with EM as measured by absolute value of discretionary accruals. However, the finding of this study contradict the result of Peasnel *et al.* (2000) who document that with higher proportion of non-executive directors on the board, there are more likely increase in discretionary accrual. Similarly, the work of Klein (2002) and Bar-Yoset *et al.* (2009) indicate that BI is a weak EM constrain.

In addition, the t-value of -0.66 suggests that the presence of female representative in the board of the sampled firms has a negative but insignificant effect on EM. The result implied that an increase in the number of female representative on the board of Nigeria cement companies other independent variables held constant constrain EM. The insignificant impact is explained by the small number of female representative on the board of Nigeria cement firms. The maximum was two female and the minimum is zero except for Ashaka cement that has one female director throughout the study period. This finding is in line with the work of Tijjani and Dabor. (2010) and Man (2012) who documented that female representative on the board of an entity improve earning quality which invariably reduces the extent of EM. The result contradicts the findings of Emilia and Sami, (2010) who document no relationship between EM and sex gender ratio.

Finally, Leverage (LEV) being the control variable has a negative and insignificant impact on EM. The result signifies that with an increase in the degree of LEV, EM decreases. This is in line with the findings of Chung et al. (2002) and Yang et al. (2008) who documented that highly indebted firms may be less able to practice earnings management because they are under close scrutiny of lenders but contrary to result of Ali et al. (2008) who documented that managers of highly leveraged firms have strong incentives to use income increasing accruals to loosen the contractual debt-constraints.

5.0 Conclusion and Recommendations

This study report findings are complementary to those in extant literature as it documents that a change in earnings management is strongly driven by board size, independence, and female participation on the board. The study concludes that large board size increases EM while board independence decreases EM. However, female directors on the board and leverage decreases EM but insignificantly among firms in the Nigerian cement companies. Furthermore, the effect of directors' independence on earnings management of firms as showed by

empirical evidence provides a plausible explanation. This has significant policy implications for the composition of the board of directors. The analysis points to the attractiveness of pluralistic board appointments, composed of independent members, corporate executives, and other parties with specific knowledge of the firms' business will go a long way in improving the capacity and capability of monitoring management to decline from opportunistic behaviour to benefit themselves at the detriment of the firm.

The study recommends that regulatory authorities like SEC, NSE and FRCN in collaboration with shareholders should ensure that the board comprises of an optimum of nine (9) members with 30% being female. Also a committee should be set up to verify the appointment of non-executive directors based on expertise, experience and reputation as this will strengthen further board independence to further safeguard and add more credibility and reliability on the quality of the financial reports of Nigerian cement companies.

References

- Adams, R., & D. Ferreira. (2009). Women in the boardroom and their impact on governance and performance. *Journal of Financial Economics* ,94, 291-309.
- Adams, R., S. Gray, & J. Nowland. (2010). Is there a business case for female directors? Evidence from the market reaction to all new director appointments. Working paper. City University of Hong Kong.
- Akers, M.D., Giacomino, D. E., & Bellovary J. L. (2007). Earnings management and its Implications. *The CPA Journal*, 79 (8), 64-68.
- Ali, A., Chen, T., & Radhakrishnan, S. (2008). Corporate disclosures by family firms. *Journal of Accounting and Economics*, 44, 238–286.
- Alves, S. (2012). Ownership structure and earnings management: Evidence from Portugal. *Australian accounting business and finance journal*, 6(1), 57-74.

- Ashbaugh, H., R. LaFond., & Mayhew, B. W. (2003). Do non-audit services compromise auditor independence? Further evidence. *The accounting review*, 78 (3), 611-639.
- Bar-Yosef, S., & Prencipe, A. (2009), Corporate governance and earnings management in family-controlled companies. Universita Bocconi, Milan.
- Beasley, M. S. (1996). An empirical analysis of the relationship between the board of directors composition and financial statement fraud. *The Accounting Review*, 71, 443-465.
- Bradbury, M., Mak, Y., & Tan, S. (2006). Board characteristics, audit committee characteristics and abnormal accruals. *Pacific Accounting Review*, 12(1),47-68.
- Carter, D. A., B. J. Simkins, and W.G. Simpson. (2003). Corporate governance, board diversity, and firm value. *Financial Review*, 38 (1), 33-53.
- Chekili, S. (2012). Impact of some governance mechanism on earnings management: An empirical validation within tunisian market. *Journal of business studies quarterly*. 3(3), 95-104.
- Cheng, E., & Courtenay, S. (2006). Board composition, regulatory regime and voluntary disclosure. *International Journal of Accounting*, 41, 262–289.
- Chin, K., Firth, M., & Kim, J. (2006). Earnings management, corporate governance, and the market performance of seasoned equity offerings. *Journal of Contemporary Accounting and Economics*, 36, 73–98.
- Chtourou, S. M., Bedard, J., & Courteau, L. (2001) Corporate governance and earnings management. <http://papers.ssrn.com/abstract=275053>.
- Cornett, M., Marcus, A., Saunders, A., & Tehranian, H. (2008). Corporate governance and pay for performance: The impact of earnings management. *Journal of Financial Economics*, 87, 357–373.

- Dalton, D.R., Daily, C.M., Johnson, J.L., & Ellstrand, A.E. (1999). Number of directors and financial performance: A meta analysis. *Academy of Management Journal*.
- Davidson, R., Goodwin-Stewart, J. & Kent P. (2005). Internal governance structure and earnings management. *Journal of Accounting and Finance*, 45, 241-267.
- Davila, M., & Watkins, K. (2009). Corporate Governance and Turnovers in Me´xico. Working paper, Universidad Popular Auto´noma de Puebla, 1–34.
- Dechow, P. & Dichev, I. (2002). The quality of accruals earnings: The role of accrual estimation errors. *The Accounting Review*, 643-655.
- Dechow, P., Sloan, R., & Sweeney, A. (1995). Detecting earnings management. *The Accounting Review*, 70, 193–225.
- DeFond, M., & Jiambalvo, J. (1994). Debt covenant violation and manipulation of accruals. *Journal of Accounting and Economics*, 17 (1-2), 145-176.
- Eisenberg, T.S., Sundgren, S., & Wells, M., (1998). Larger board size and decreasing firm value in small firms. *Journal of Financial Economics*, 48, 35-54.
- Emilia, P., & Sami, V. (2010). Female executives and earnings management. *Journal of managerial finance*, 36(7), 629-645.
- Fama, E., & Jensen, M. C. (1983). Separation of ownership and control. *Journal of Law and Economics*, 26(2), 301–325.
- Fernandez, A., Gomez, S., & Fernandez, C. (1997). The effect of board size and composition on corporate performance. In M. Balling, *et al.*. (Eds.), *Corporate governance, financial markets and global convergence*. Boston: Kluwer Academic Publishers.
- Fondas, N. & Sassalos, S. (2000). A different voice in the boardroom: how the presence of women directors affects board influence over management. *Global Focus*, 12, 13-22.

- Graham, J.R., Harvey C.R., & Rajgopal, X. (2005). The Economic Implications of Corporate Financial Reporting. *Journal of Accounting and Economics*, 3-73.
- Hambrick, D., Nadler, D., Tushman, M. (1998). Navigating change: How CEOs, Top Teams, and Boards Steer Transformation. Harvard Business School Press, Boston, MA.
- Hamid, K.T. (2008). An Assessment of the relationship between corporate Governance and Internal Control System in the Nigerian Banking Industry. A PhD Accounting Thesis Submitted to the School of Post Graduate Studies, Bayero University, Kano.
- Healey, P.M. & Wahlen, J. (1999). A Review of the earnings management literature and its implication for standard settings. *Accounting Horizons*, 13(4),365-383.
- Healy, P. (1985). The effect of bonus schemes on accounting decisions. *Journal of Accounting and Economics*, 7(1-3), 83-107.
- Jaggi, B., Leung, S., & Gul, F. (2009). Family control, board independence and earnings management: Evidence based on Hong Kong firms. *Journal of Accounting and Public Policy*, 28(4), 281-298.
- Jensen, M.C. (1993). The Modern Industrial Revolution, Exit and the Failure of Internal Control Systems. *Journal of Finance*, 48, 831-880.
- Jones, J. (1991). Earnings management during import relief investigations. *Journal of Accounting Research*, 29(2), 193-228.
- Kam, P.M. (2006). Corporate governance and earnings management: some evidence from hong kong listed companies. (Phd thesis) faculty of business, university of sunshine coast, Australia.
- Klein, A. (2002a). Economic determinants of audit committee effectiveness. *The Accounting Review*, 31, 435-454.

- Klein, A. (2002b). Audit committees, board of directors characteristics and earning management. *Journal of Accounting and Economics*, 33, 375-400.
- Klenke, K. (2002). Women weaving webs: the transformative powers of technology. Paper presented at the 1st Global Transformation in Politics, Culture and Society Conference, Brussels on 6-8 December.
- Kothari, S., Leone, A., & Wasley, C. (2005). Performance matched discretionary accrual measures. *Journal of Accounting and Economics*, 39(1), 163–197.
- Liu, Q. & Lu, Z. (2007). Corporate governance and earnings management in Chinese listed companies: A tunneling perspective. *Journal of Corporate Finance*, 13, 881-906.
- Marnet, O. (2008). Behaviour and rationality in corporate governance. *International Journal of Behavioural Accounting and Finance*, 1, 4-22.
- Mohammed, A., & Pourtazeem, A. (2012). Corporate governance and earnings management and the relationship between economic value added and created shareholder value. *African journal of business management*, 6(15), 5376-5382.
- Oladipupo, A.O., & Okafor, C.O. (2010). The impact of earnings management and corporate governance on firm performance. *Bayero International Journal of Accounting Research*, 4, (1).
- Park, Y. W., & Shin, H. H. (2004). Board Composition and Earnings Management in Canada. *Journal of Corporate Finance*, 10(3), 431-457.
- Peasnell, K. V., Pope, P. F., & Young, S. (2005). Board monitoring and earnings management: Do outside directors influence abnormal accruals? *Journal of Business Finance & Accounting*, 32 (8), 1311-1346.

- Powell, M., & Ansic, D. (1997). Gender differences in risk behavior in financial decision making: An experimental analysis. *Journal of Economic Psychology*, 18(6), 605-28.
- Rahman, R., & Ali, F. (2006). Board, audit committee, culture and earnings management: Malaysian evidence. *Managerial Auditing Journal*, 21(7), 783.
- Randoy, T., and J. I. Jenssen, (2004). Board independence and product market competition in Swedish firms, *Corporate governance: an international review* 12, 281-289.
- Rose, C. (2007). Does female board representation influence firm performance? The Danish evidence. *Corporate Governance: An International Review*, 15(2), 404-413.
<http://dx.doi.org/10.1111/j.1467-8683.2007.00570.x>.
- Samaila., A. I., (2014). Corporate governance and financial reporting quality. An analysis of Nigeria petroleum marketing companies. An Unpublished (PhD thesis) submitted to the Department of Accounting, Bayero University, kano.
- Santiago, M., & Brown, C. (2009). An empirical analysis of Latin American board of directors and minority shareholders' rights. *Forum Empresarial*, 14(2), 1–18.
- Sarkar, J., Sarkar, S. & Sen, K. (2008). Board of directors and opportunistic earnings management: evidence from India, *Journal of Accounting, Auditing & Finance*, 23(4), 517-51.
- Sunden, A.E. & B. J. Surette. (1998). Gender differences in the allocation of assets in retirement savings plans. *American Economic*, 88, 207-11.
- Teoh, S., Welch, I., & Wong, T. (1998). Earnings management and the underperformance of seasoned equity offerings. *Journal of Financial Economics*, 50, 63–99.
- Tijjani, B. & Dabor, E. L (2010). The impact of earnings management and corporate governance on firm performance. *Bayero International Journal of Accounting Research*, 4(1).

- Uadiale, M.O. (2012). Earnings management and corporate governance in Nigeria. *Research journal of accounting and finance*. 3(3).
- Vafeas, N. (2000). Board structure and the informativeness of earnings. *Journal of Accounting and Public Policy* 19(2), 139–160.
- Watson, J. (2002). Comparing the performance of male- and female-controlled businesses: relating outputs to inputs. *Entrepreneurship Theory and Practice*, 26(3), 91-100.
- Waweru, N.M., & Riro, G.K. (2013). Corporate governance, firms characteristic and earnings management in an emerging economy. *JAMAR*, 11(1), 43-64.
- Wikipedia, (2012). Corporate Governance. http://en.wikipedia.org/wiki/Corporate_governance Accessed on 21/12/12.
- Xie, B., Davidson III, W. N., & DaDalt, P. J. (2003). Earnings management and corporate governance: The Role of the Board and the Audit Committee. *Journal of Corporate Finance*, 9(3), 295-316.
- Yang, J.S. & Krishnan, J. (2008). Audit committee and quarterly earnings management. *International Journal of Auditing*. 9, 201-219.
- Zahra, S. A., & Pearce, J. A. (1989). Boards of directors and corporate financial performance: A review and integrative model, *Journal of Management*, 15(1), 291-312.
- Zattoni, A., & Cuomo, F. (2010). How independent, competent and incentivized should non-executive directors be? An empirical investigation of good governance codes. *British Journal of Management*, 21, 63–79.

THE VALUE-RELEVANCE OF ACCOUNTING INFORMATION IN NIGERIA:THE PERCEPTION OF ACCOUNTANTS IN THE IFRS REGIME

Ahmad Bukola **Uthman**

¹Department of Accounting, Al-Hikmah University, Ilorin, Nigeria.

Abstract: This study investigates the effect of IFRS adoption on the value-relevance of accounting information in Nigeria. The study builds on the explanation of extant finance theories on the value and timing of information. IFRS was measured with more disclosure of economic events as well as the fair valuation of economic events under IFRS. The opinions of a number of financial analysts with the aid of e-mail questionnaire were sourced. A log-linear test was run to test the interaction of the variables and the significance of such interaction. A significant relationship was found between the each of the independent variables and the dependent variable at 5% level of significance. The study therefore offers explanations regarding the IFRS adoption as a bridge of the gap between accounting and finance measurement of information. Hence, concludes that IFRS adoption has enhanced the value relevance of accounting information in Nigeria. However, recommendation was made that more measures should be put in place to ensure full compliance of IFRS by all affected Nigerian entities.

Keywords: fair value; IFRS; Nigerian GAAP; finance theory; economic disclosure

1. Introduction

Inherent in the profession of accounting are rules and principles that give room for manipulations and designs by professional accountants. Hence, given the required skill and accounting acumen, two accountants could present two different profit figures from the same records and none would be considered to have erred in so far as he considers some underlying concepts in the preparation of his accounts. Advocates of fair value accounting see the key motivation in reporting all assets in the balance sheet at fair value because it is more current and perhaps more relevant (Cunningham, 2005). However, accounting traditionally measures most assets using historical cost because it is considered reliable. This serves as the basis of annual depreciation of the historic value of an asset as it is justified by its consistent burdening of income of accounting periods with the supposed equivalent contribution of the depreciated asset to the generation of such incomes. This tradition is faulted both in basis and methods. Depreciation methods are numerous and also produce different depreciation figures. This and several other examples dominate the principle and practices of accounting. The exploitation of the loopholes created by the accounting rules to generate undeserved and unwarranted benefits is referred to as designed accounting or creative accounting. Also termed macro-manipulation, income smoothing, earnings management, earnings smoothing, financial engineering cosmetic accounting or window dressing (Belkaoui, 2004; Amat, Blake & Dowds, 1999; Zeljana & Klepo 2006), designed accounting is defined as "the opportunistically used discretion over accounting numbers with intention to mislead users of the information" (Zeljana & Klepo 2006, p. 274).

Applied faithfully, the harm caused by the strict adherence to accounting rules could have been restricted to the relevance and reliability of the figures it produces in terms of time value of money. By extension however, the loopholes created by these rules have been exploited by fiendish accountants to perpetrate fraud and this has taken a toll on the profession as it has manifested in an upsurge of

accounting scandals across the globe thereby having implications for the public confidence in the profession.

This paper considers the arguments of the proponents of finance theory to evaluate the relevance of accounting data produced out of historical values and the opportunities provided by accounting rules to distort accounting figures. It further explores the recent move towards fair-value approach as introduced by the fast growing IFRS adoption in favour of its currency and perhaps, the likelihood of being more relevant than the figures produced by historical cost valuation. Since the popularization of IFRS, research outputs on the evaluation of the value-relevance of accounting information in Nigeria is scarce. Notwithstanding, the condemnation of the accounting data by the proposition of the finance's efficiency theory may have been overcome by the adoption of a supposed more reliable method (Fair Value Accounting). Therefore, the value relevance of accounting information is examined by evaluating the accountants' perception in the IFRS era.

2. Literature Review

This section is organized into five(5) subsections to explore literature relating to the The value-relevance of accounting information in the fair-value regime. The next subsection gives the theoretical exposition of the work. The following sections discuss the the conceptual framework and the hypotheses development.

2.1. Theoretical Framework

The theories of corporate finance started with the birth of corporations. At inception, it was "riddled with logical inconsistencies and was almost totally prescriptive, that is, normative oriented" (Jensen & Smith, 1984, p.2). The significance and civilization of finance began to occur in the 1950s when the "analytical methods and techniques traditional to economics began to be applied to problems in finance [which therefore led to the] formulation of major building blocks in modern theory of financial economics" (Jensen & Smith, 1984, p.3). Hence, theories like the Efficient Market Hypothesis, Portfolio Theory, Capital Asset Pricing Theory, Option Pricing Theory and Agency Theory were formulated. Central to the relevance of information in finance is the Efficient Market Hypothesis (EMH) which is adopted herein.

The concept of Efficient Market Hypothesis informs the classification of information in relation to their sensitivity to stock prices. Basically,

information are considered strong when they incorporate all available information, semi strong with the incorporation of all publicly available information and weak when they incorporate only historical information (Hadi 2006; Akintoye 2008; Jain, 2012; Nwaolisa&Kasie 2012). A Strong Form of Efficiency of a market is understood when "every information regarding historical process, earnings, mergers, accounting statements and all publicly and privately traded....is already incorporated in the process of the stock" (Jain 2012, p. 18). The reflection of information other than just historic information determines the strength of the strong form over the others. Although, it has been argued that the semi-strong form of market hypothesis is relevant for accounting information because it is the primary source of public information through the issue of financial reporting (Hadi, 2006), the relevance of accounting information has been met with scepticism by various scholars(see Cunningham, 2005; Yang, Rohrbach& Chen, 2005;Devalle, Onali&Magarini, 2012).

Cunningham (2005), discussing through the lens of finance theory argues that accounting information, being majorly historic data, "is rapidly impounded into stock price.... and any effort to improve accounting theory or practice is meaningless" (p. 3).He believes that if accounting information had been considered relevant and reliable, "there is no point searching for an optimal form [of market hypothesis]" (p. 3). In numerous contexts, "economic inferences and decisions are based on measures of historical costs" (Rajan&Reichelstein, 2009, p. 824). The relevance of accounting data is further threatened by the economists as they "believe that historic data are sunk and therefore have little economic relevance with regard to current economic conditions (Rajan&Reichelstein, 2009, p. 824).

Accounting data is based on principles which permit the use of differing procedures in different situations and hence report earnings that may be difficult to rely upon for economic decision. However, the "market value of assets is the present value of their cash flow discounted at appropriate risk-adjusted rate" (Akintoye, 2008). Hence, "market price responds to cash flow effects of managerial decision and policy, not to the effect on reported earnings per share" (Cunningham, 2005, p.3) as presented by accounting data on periodic basis.

Accounting data is also faulted due to its reliance on the allocation of economic events to discrete time periods (Cunningham, 2005). This is the crux of accrual concept of accounting. To illustrate this, Rajan&Reichelstein (2009) noted that the depreciation and amortization of assets based on historic values conforms perfectly to accrual accounting. The current income statement reflects depreciation and amortization expenses of past asset acquisitions. This could hamper the reliability of the income values produced from such accounting statement and hence decisions thereupon.

2.2. Conceptual Issues

2.2.1 Macro-Manipulation and Designed Accounting: Implications for the relevance of accounting information

The opportunity to present a picture that sends a signal that shapes peoples' perceptions of managerial performance and mislead information users is presented by designed accounting. It takes different dimensions such as income smoothing, creative accounting, earnings management etc. (Belkaoui 2004). Although these dimensions share similar basis, they are applied in different situations to different objectives. While Earnings Management is done by "structuring transaction to alter financial reports to either mislead some stakeholders....or to influence contractual outcomes that depend on reported accounting numbers" (Kepsu, 2012, p. 25), income smoothing involves "deliberate choice and timing of transactions that can affect cash flows and control underlying events" (Belkaoui, 2004, p. 56). It is basically done to moderate yearly fluctuations in income by shifting earnings from peak years to less successful periods (Copeland, 1968) hence aligning reports of wide variations among periods to bridge the gap of a sharp decrease in earnings reported by during those periods. Creativity in accounting takes a dimension of exploiting the loopholes and flexibilities in accounting rules. It implies a "liberal interpretation of accounting rules allowing choices that may result in a depiction of financial situations that are more optimistic than the real situations" (Belkaoui, 2004, p.57) perhaps to make some financial gains or deceive users of accounting data. Copeland (1986) cited in Amat&Gowthrope (2002) considers that

"it involves the repetitive selection of accounting measurement or reporting rules in a particular pattern, the

effect of which is to report a stream of income with a smaller variation from trend than would otherwise have appeared” (p.5)

Regardless of whatever form it takes however, the effect of designed accounting is felt more by the output it produces for users to rely upon. It has though been argued that designed accounting is sometimes done for positive intension such as: to ensure the reporting of stable earnings, to avoid payment of tax or to increase the confidence of shareholder in the performance of the enterprise (see Niskanen&Keloharju, 2000; Herrmann & Inoue, 1996; Amat&Gowthrope2002), the bottom line still remains that designed accounting dampens the values of accounting data.

The case of fraud in Enron is one of the most widely reported cases with major inputs from designed accounting. “Enron took full advantage of accounting limitations in managing its earnings and balance sheet to portray a rosy picture of its performance” (Healy &Pelepu, 2003 p.10). The scheme was perfectly orchestrated so as to recognize, in present terms, forecast of prices and interest well into the future. Special Purpose Entities (SPEs) were also set up to disguise arms-length transactions as related party’s transactions. The Entity concept of accounting was abused to make this a reality. It took the forms of “failure to consolidate entities, selective use of the equity method of accounting for entities, and failure to eliminate the effect of transactions among the entities” (Cunningham & Harris, 2006 p.41). More so, “Mark-to-market accounting” was aggressively implemented in Enron. Mark-to-market accounting is operated to report derivatives at fair market values instead of historical costs (Cunningham & Harris, 2006). This happened in Enron with ease because active markets did not exist for contracts that sometimes had terms as long as 20 years as Cunningham & Harris (2006) succinctly elucidate:

“How did mark-to-market accounting work in Enron? Assume Enron had two option contracts matched over the same time period for the same amount of commodity; one contract was to buy the commodity and the other contract was to sell the commodity. Enron would look into the future, assume both contracts were exercised and net the results. After allowing for delivery costs and for reserves for other unforeseen costs, the net income(loss) was estimated over the life of the

matched contracts. Then this estimated net income (loss) was discounted for the time value of money, to its present value and recorded as a gain (loss). The method required that each year the estimated future earning be re-estimated and marked up or down" (p.40)

Given these antecedents, the value-relevance of accounting data is threatened as widely supported in the finance and economics literatures. Avenues have been created for critics overtly and covertly to castigate the data produced by the traditional accounting methods. Wai (2008) considered that "accounting information constitutes a noisy representation of economic reality due to the spectrum of accounting alternatives available to meet a diversity of information needs" (p.179). Illustrating the "noise" in accounting information, Wai (2008) explained that:

"two key accounting summaries of a firm's economic reality, net income and net assets, have been called noisy signals of wealth due to the sheer number of options available in constructing accounting numbers – e.g. LIFO versus FIFO in inventory evaluation, straight line depreciation versus reducing balance depreciation – to meet a diversity of information needs" (p.180)

The argument that: "accounting information of firms and their competitors aid managers and investors in identifying and evaluating investment opportunities" (Bushman & Smith, 2003, p.67) cannot be completely discountenanced as the "noise" in accounting information, according to Mattessich (2005) does not nullify the usefulness of accounting information as long as decision makers are conscious and wary of the noise within the information. It nonetheless, dashes a skeptic view at the reliability and relevance of accounting data in making informed decisions. Plethora of accounting fraud has been reported both prior and subsequent to the event of Enron. The causes of the eventualities, which are mostly not unconnected with cosmetic accounting, are made known to public which in turn hamper the confidence they have in the output of the profession thus having implications for public confidence in accounting profession. Figure 1 below succinctly describes the transformation of raw data into accounting information before the adoption of IFRS.

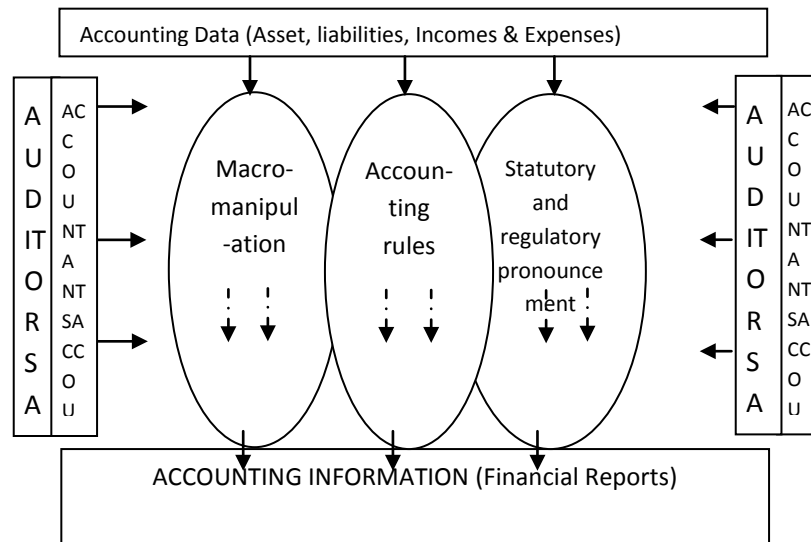

Fig. 1 accounting data processing prior to Fair Value Accounting adoption and the Enactment of Financial Reporting Council Act in Nigeria

Source: Adapted from Kettunen(2011)

Figure 1 above depicts the flow and processing of accounting data. Given that accountants and auditors are the experts and major players in the conversion of accounting data into information through the preparation, presentation and auditing of financial reports, accounting data passes through the thorough scrutiny of accounting rules. Both accounting manipulation and regulatory and statutory pronouncements serve as either positive or negative influence on the accounting rules which are applied on the data input before transformation into accounting information. Accounting manipulation is considered a "liberal interpretation of accounting rules allowing choices that may result in a depiction of financial situations that are more optimistic than the real situations" (Belkaoui, 2004, p.57). Enron's case is a clear testimony to this as Healy & Pelepu(2003) observed that "Enron took full advantage of accounting limitations in managing its earnings and balance sheet to portray a rosy picture of its performance" (p. 10).

More so, the regulatory and professional pronouncements cannot be considered absolutely infallible in the way they influence the transformation of accounting data into financial reports. Company and

Allied Matters Act (CAMA) (1999 as amended) of Nigeria has its equivalent in almost all the countries of the world as enacted by concerned government bodies to enact laws that reshape financial accounting rules. The tendency is to set rules that satisfy government needs such as computing income taxes or demonstrating compliance with national government policies and macroeconomic plans (Ali & Hwang, 2000). This in many instances has run in conflict with accounting practices that are determined primarily by accountants, whose objective is more likely to be the integration of emerging accounting ideas into the existing structure of standards (Wyatt, 1997). Such is the case when the Nigeria's CAMA requires the preparation of separate financial statements in respect of two companies within a group of companies but have dissimilar activities as against the requirement of the international Accounting Standard where it is explicitly stated that "A subsidiary is not excluded from consolidation because its business activities are dissimilar from those of the other entities within the group" (IAS 27, p.A615). Accounts prepared in compliance with either would not be considered incorrect when in actual fact may have produced conflicting profit figures.

2.2.2. The Enactment of FRCN Act⁴, IFRS adoption and Financial Reporting in Nigeria

In an effort to place accounting and financial reporting practices in Nigeria on the same footing as that of the world's best practices, the "FRCN Act" was enacted. In the presentation of a paper in 2012 at a retreat with accounting lecturers in Nigerian Universities, the Director of the council, Jim Obazee Osaynade noted that the "council will require management assessment of internal controls, including Information Systems Controls with independent attestation" (p. 25). He stated further that as part of the FRC oversight of professionals, "the FRC requires a good code of ethics for financial officers and certification of financial statements by chief executive officers and chief financial officers" (Osayande, 2012 p. 23) of reporting entities. More so, the council will reinvigorate efforts in restoring public confidence in financial reporting as it "issues code of corporate governance and

⁴Financial Reporting Council of Nigeria Act was enacted on 7th June 2011 to repeal the Nigerian Accounting Standard Board Act, No.22 of 2003 hence, charged with the responsibility for, among other things, developing and publishing Accounting and Financial Reporting Standards to be observed in the preparation of financial statement of public entities in Nigeria; and for related matters. (FRCN Act,2011 p.A59

guidelines, and develop a mechanism for periodic assessment of the codes and the guidelines” (Osayande, 2012, p. 23). Arguing further for the enactment of the FRCN act, Anao (2012) “considers that the development is timely as “it expands the scope of financial regulation beyond traditional spheres of accounting and financial reporting and also spans auditing and corporate governance” (p. 5). The increased involvement of government in financial reporting presents a picture that is ardently passionate about the public interest. Perhaps, because of the plethora of bank fraud exposures recorded in recent times in Nigeria and the urgent need to align with international best practices.

2.2.3. IFRS adoption and the value-relevance of Accounting Information

Fair Value Accounting has shifted the paradigm of Accounting since “a major feature of IFRS *qua* standards is the extent to which they are imbued with fair value accounting” (Ball, 2005, p.19). In history, Fair value accounting “has played an important role in U.S. generally accepted accounting principles (GAAP) for more than 50 years” (Ryan, 2008, p.4). It has been described as “the amount for which an asset could be exchanged, or a liability settled, between knowledgeable, willing parties in an arm’s length transaction” (IFRS 3), apparently, it departs from historical cost accounting” (Jensen 2007, p.307). Although it shares similar features with liquidation valuation, it is considered as a concurrent exit value because it does not take cognizance of the accompanying cost of liquidating underlying assets as in the case of liquidation values. Accounting literature is replete with arguments against fair valuation. It has mostly been criticized on the ground that it brings about “adjustment that cause enormous fluctuations in earnings, assets and liabilities that are washed out over time and never realized” (Jensen 2007, p.308). However, testimonies of its radicalism in improving the scope for market discipline, accounting information and corrective actions are countless. “It is increasingly acknowledged in both the academic literature and the supervisory debate that the discipline exercised by informed and uninsured investors is an essential complement of supervisory control” (European Central Bank, 2004 p.9) created by the fair value accounting. It has also been practically proven that fair value accounting aligns positively both during upturns and downturns. Barth, Gomez-Biscarri & Lopez-Epinosa (2012) observe:

"It leads to stronger cyclicity of accounting variable: in the upturns of the economy fair value would allow for revaluation of assets..... and in downturns only fair value accounting would recognize bad news when fair value is above the cost" (p.1).

Hitz's (2005) dual theoretical backdrop of the fair value paradigm is notable at this juncture. First, he considers fair-value-based accounting information as a complete embodiment of all the informational needs of a hypothetical market price thereby elevating accounting information to a strong form of market hypothesis. This is a countercurrent to the proposition of Cunningham (2005) who derogated accounting data as being "impounded into stock price" (p.3). Hitz (2005) presents fair value accounting to salvage the situation as he posits that "fair value paradigm presents market prices that aggregate in an efficient and virtually unbiased manner the consensus expectations of investors in the market concerning the cash flow pattern of the security" (p.8). Second, he argues that "investors can extract implicit consensus information from market prices in order to revise and improve their own projections" (p.8) thereby enabling users of accounting information to make accurate forecast and informed economic decision as paraded by the finance theory.

2.2.4. Empirical Framework

Extant research outputs are replete with empirical evidences that suggest the significance of IFRS to the value relevance of accounting information. A study conducted by Kim, Tsui & Cheong (2007) revealed that a sample of non-US borrowers who voluntarily switched to IFRS experienced lower borrowing costs in periods subsequent to the adoption. Christensen, Lee and Walker (2008) made similar points with respect to the effect of voluntary adoption of IFRS and earnings management. They also discovered that timely loss recognition increases after voluntary IFRS adoption. More so, a survey of 10,017 firms in china comparing the pre and post IFRS adoption era by Lee, Walker&Zeng (2013) revealed that IFRS convergence had generally beneficial effects on value relevance of accounting information. Although the findings of Barth, Landsman & Lang (2008) is considered on international Accounting Standards and Accounting quality, their conclusion is consistent with the result of Lee, Walker &Zeng (2013) as they are also of the conclusion that firms applying IFRS exhibit less

earnings smoothing, less managing of earnings towards a target, more timely recognition of losses, and a higher association of accounting amounts with share prices and returns.

According to Tarca (2008), the aim of adopting IFRS in Australia was to improve the international comparability of Australian companies' financial reporting. Empirical findings have proven this as the conclusion of Brochet, Jagolinzer and Riedl (2011) shows that mandatory IFRS adoption reflects benefits attributable to improved comparability. Notable however is the submission of a contrary view as revealed by the work of Callao, Jarne & La'inez (2007) who found that the main causes of the significant variation in current assets were the application of fair value to financial instruments, the reclassification of accounts, and changes in the scope of consolidation notwithstanding however that their own findings (Callao *et al*, 2007) is based on the comparability of IFRS and local SAS after adaptation to IFRS in the years of adoption. More so, the results of Wu and Zhang (2011) suggest that with greater globalization and accounting convergence firms likely increasingly turn to foreign peers as benchmarks for evaluating managers. "Comparability in financial statements is vital for investors to draw reasonable conclusions about the relative performance of entities" (Deloitte, 2012), perfect comparability may not be practicable but putting the preparation of reports on equal footing will enhance a more meaningful comparability and hence assist in cross-border decision making. A conceptual model from these assertions is presented below:

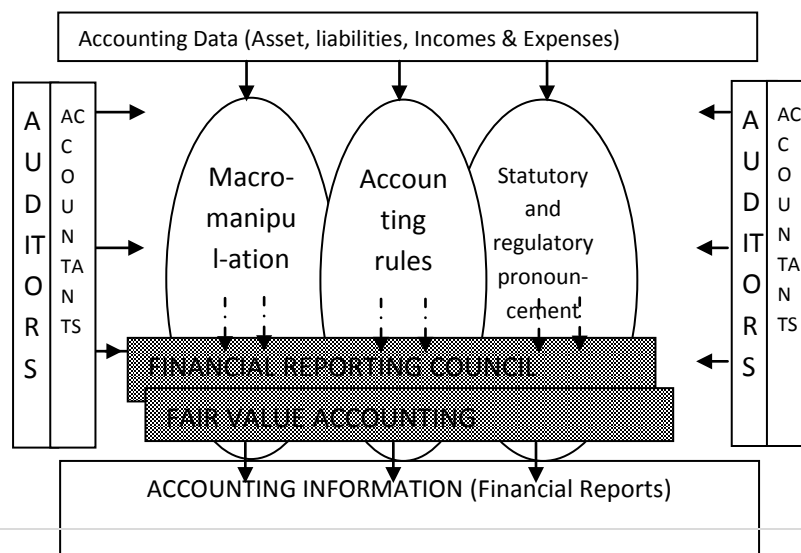

Figure 2: The effects of Fair Value Accounting and Financial Reporting Council in the processing of accounting data.
Source: adapted from Kettunen, (2011)

Learning from the framework presented in figure 1, the above figure captures how the enactment of Financial Reporting Council Act of Nigeria and the adoption of fair value accounting serve as a sieve that sieves out relevant and reliable accounting information from the accounting data input into the accounting system.

2.2.5 The Research Hypotheses

To empirically test the views about the effect of the adoption of IFRS on financial accounting information, the following hypotheses are tested:

Ho₁: More disclosure of economic events under IFRS than GAAP has not enhanced the relevance of Accounting Information.

Ho₂: The adoption of fair value accounting for measuring economic events under IFRS has not enhanced the relevance of Accounting Information.

3. Methodology, Data Analysis and Interpretation of Results

The study adopts a survey design approach. Specifically, financial analysts form the population of the study. The Institute of Chartered Accountants of Nigeria (ICAN) online professional forum which consists of 3,100 professional members (when the questionnaire was sent) was adopted as the sampling frame for the distribution of the questionnaire. Specifically, questionnaire items were structured to be completed by chartered accountants practicing as financial analysts in the Nigerian Stock Exchange. The questionnaire was designed to elicit information

on their perceived change in the value-relevance of accounting information since the adoption of IFRS in Nigeria. The items were categorical with '1' representing "Yes" and '0' representing "No". The items were couched to provide direct and unambiguous responses.

The questionnaire was posted to the forum consecutively for ten weeks through the Google mail questionnaire facility- Google drive. It was preceded by a covering letter, soliciting for objective opinion and avoidance of multiple responses. At the end of the ten weeks, a total response of 140 was received out of which 5 were unusable for the analysis of the study because of incomplete responses. Thus, 135 responses were processed for the analysis. Descriptive statistics and log-linear analysis were used for data analysis with the aid of SPSS 17.

3.1 Descriptive Analysis

Table 1 below indicates the distribution of the respondents' profile. 44.4 percent of the respondents have experience of 10 years and above working as financial analysts while only less than 6 percent of the entire respondents have less than 3 years' experience. Above 99 percent of the respondents have a professional certification as financial analysts while 88.9 percent of these are adequately qualified as they are associate members of their respective professional bodies. Hence, the respondents' exposure, experience and qualification fit reasonably to provide needed response.

Table I: Respondents' Profile

Description	Frequency	Percentage
Experience (Years)		
1-3	8	5.9
4-6	34	25.2
7-9	33	24.4
10 and above	60	44.4
Total	135	100.0
Academic Qualification		
B.sc/HND	69	51.1

M.SC/MBA	66	48.9
Total	135	100.0
Professional Qualification as Financial Analyst		
Yes	134	99.3
No	1	.7
Total	135	100.0
Membership Status		
Student Member	3	2.2
Associate Member	120	88.9
Fellow Member	12	8.9
Total	135	100.0

Table II below shows the Cross-tabulation of the interaction between the three variables of interest and depicts the number of cases that fall into each combination of categories. In total, 82 (91.1% of total) of the respondents that believe that there were more disclosure of economic event under IFRS subscribe to the proposition that such disclosure has enhanced the value-relevance of accounting information. However, 9 (8.9% of the total) of the respondents opine otherwise. However, 27 (65.9 percent) of the respondents that believe fair value model has been adopted in measuring economic events agree to the proposition that fair value adoption has enhanced the value-relevance of accounting information in Nigeria. 14 (34.1 percent of total) believe otherwise. Meanwhile, the assumption required of a set of data to qualify for analysis with the use of log-linear test is that; none of the expected counts must be less than 1 while expected counts less than five must be less than 20 percent of all (Field, 2005). The smallest expected count provided in the cross tabulation shown in table II below is 3.1. More so, it is the only count that falls below 5 which is 10 percent of the entire expected counts (i.e. below 20

percent). Therefore the assumption of log-linear analysis has been met.

Table II: Cross-tabulation of value – relevance* fair value measurement*more disclosures under IFRS

Enhancement of the Value-Relevance of Accounting Information				Fair value model in measuring Economic Events		Total
				No	Yes	
No	More disclosures of Economic Events under IFRS	No	Count	6	3	9
			Expected Count	3.1	5.9	9.0
			% More disclosure of Economic Events under IFRS	66.7	33.3	100.0
			% Fair value model in measuring Economic Events	42.9	11.1	22.0
			% of Total	14.6	7.3	22.0
		Yes	Count	8	24	32
			Expected Count	10.9	21.1	32.0
			% More disclosure of Economic Events under IFRS	25.0	75.0	100.0
			% Fair value model in measuring Economic Events	57.1	88.9	78.0
			% of Total	19.5	58.5	78.0
Total		Count	14	27	41	
		Expected Count	14.0	27.0	41.0	
		% More disclosure of Economic Events under	34.1	65.9	100.0	

			IFRS			
			% Fair value model in measuring Economic Events	100.0	100.0	100.0
			% of Total	34.1	65.9	100.0
Yes	More disclosure of Economic Events under IFRS	Yes	Count	8	82	90
			Expected Count	8.0	82.0	90.0
			% More disclosure of Economic Events under IFRS	8.9	91.1	100.0
			% Fair value model in measuring Economic Events	100.0	100.0	100.0
			% of Total	8.9	91.1	100.0
	Total		Count	8	82	90
			Expected Count	8.0	82.0	90.0
			% More disclosure of Economic Events under IFRS	8.9	91.1	100.0
			% Fair value model in measuring Economic Events	100.0	100.0	100.0
			% of Total	8.9	91.1	100.0

Furthermore, a goodness-of-fit test was run to test the hypothesis that the expected frequencies are significantly different from the actual frequency. The expected result for a good fit is that our model is not

significantly different from our data. Thence, we expect this statistics to be non-significant. Our result as shown in Table III below indicates that both the statistics (Likelihood ratio and Pearson) are 0 and yield a probability value, p , of '.' Which according to Field (2005) indicate that the model perfectly predicts the data.

Table III: Goodness-of-Fit Tests

	Chi-Square	Df	Sig.
Likelihood Ratio	.000	0	.
Pearson	.000	0	.

Consistent with the satisfaction of these assumptions, the model of the study is given thus:

$$\ln(\text{RAI}_{ij}) = (\lambda_0 + \lambda_1 \text{MD}i + \lambda_2 \text{FV}j + \lambda_3 \text{MD}i\text{FV}j) + \ln(\epsilon_{ij})$$

Where:

λ = Intercept of the equation

ϵ = Error term

RAI = Relevance of Accounting Information

MD = More disclosure of economic events under IFRS

FV = Adoption of fair value accounting for measuring economic events.

3.2. Log-linear Analysis

Given that Log-linear analysis is done hierarchically, the highest order interaction (i.e. the 3 way interaction) in hierarchy takes the lead. The likelihood ratio and Pearson chi-square statistics indicate that the highest order effect (the 3 way interaction) testing the significance of the interaction between the 3 variables is not significant thereby suggesting its removal from the model. Meanwhile, it is not represented in the model of this study as the objective of the study precludes the interaction between the 3 variables. Hence its removal from the model does not significantly affect how well the model fits the data. However, $k = 1 \& 2$ tells us, at 99 percent confidence interval, that removing the main effects of RAI, MD and FV (one-way effect) and the interaction between RAI & MD, RAI & FV and MD & FV (2 way

interaction) would have a significant detrimental effect on our model. Hence their retention in the model is paramount pre-requisite for further analysis as suggested by the statistics.

Table IV K-Way and Higher-Order Effects

	K	df	Likelihood Ratio		Pearson		Number of Iterations
			Chi-Square	Sig.	Chi-Square	Sig.	
K-way and Higher Order Effects ^a	1	7	237.395	.000	325.366	.000	0
	2	4	39.557	.000	78.013	.000	2
	3	1	.000	.996	.000	.996	4
K-way Effects ^b	1	3	197.838	.000	247.353	.000	0
	2	3	39.557	.000	78.013	.000	0
	3	1	.000	.996	.000	.996	0

a. Tests that k-way and higher order effects are zero.

b. Tests that k-way effects are zero.

Interesting as they appear, the K-way and higher order effects only indicate whether removing a higher order effect would significantly affect the model. It does not specifically identify the 2 way interaction that is having the significant effect. Table V depicts the Pearson chi-square test to test for the significance of the effect of each of the interaction. It depicts that at 99 percent and 95 percent confidence intervals, the interaction between RAI and MD as well as between RAI and FV have significant effects.

TableV: Partial Associations

Effect	Df	Partial Chi-Square	Sig.	Number of Iterations
--------	----	--------------------	------	----------------------

RAI*MD	1	15.297	.000	2
RAI*FV	1	4.827	.028	2
MD*FV	1	5.197	.023	2
RAI	1	18.782	.000	2
MD	1	116.034	.000	2
FV	1	63.023	.000	2

However, Table VI shows the individual estimates using the z-score rather than the chi-square so as to harness useful comparison between the effects. From the estimates, the most important effect is the effect of MD ($z=-4.67$) followed by the MD*RAI interaction ($z=2.633$) and then FV*RAI ($z=0.843$).

Table VI: Parameter Estimates

Effect	Parameter	Estimate	Std. Error	Z	Sig.	95% Confidence Interval	
						Lower Bound	Upper Bound
RAI*MD*FV	1	-.074	.272	-.274	.784	-.607	.458
RAI*MD	1	.716	.272	2.633	.008	.183	1.248
RAI*FV	1	.229	.272	.843	.399	-.304	.762
MD*FV	1	.494	.272	1.817	.069	-.039	1.027
RAI	1	.412	.272	1.516	.129	-.121	.945

MD	1	-1.269	.272	-	.000	-	-.736
				4.67		1.80	
				0		2	
FV	1	-.339	.272	-	.212	-	.194
				1.24		.872	
				7			

In summary, the 2-way log-linear analysis produced a final model that retains all effects. The likelihood ratio of this model was $X^2(0)=0$, $p=1$. This indicated that the 2-way interaction (more disclosure and relevance of accounting information; fair value adoption and value relevance of accounting information and; more IFRS disclosures and Fair Value adoption) was significant, $X^2(4)=39.56$, $p<0.001$. To break down these effects, the partial association indicates that there is a significant association between "more disclosure of economic event under IFRS" and whether or not the value relevance of accounting information is enhanced, $X^2(1)=4.827$, $p<0.05$; this also indicates an important relationship given the z-score ($z=2.633$). The partial association further depicts that there is a significant association between fair value adoption and whether or not the value-relevance of accounting information is enhanced. However, this interaction is less important as it depicts a lesser z-score ($z=0.843$). Therefore, the analysis seems to reveal a fundamental effect of IFRS adoption on the value relevance of accounting information between the need to disclose more information under IFRS and the need to adopt fair value measure in denominating economic events. Hence, more disclosure is more likely to enhance value relevance of accounting information than the need to adopt fair value model. Nevertheless, both have significant effects.

4. Summary and Conclusion

The adoption of IFRS has been one of the most recent major challenges of the accounting profession. Notwithstanding the provision of the erstwhile GAAP attached to the fidelity of accounting profession in Nigeria, the Nigerian lawmakers passed the FRCN act to ensure, amongst others, a practicable roadmap to the adoption of IFRS in

Nigeria. Needless to say, the adoption of IFRS will either attenuate the relevance of accounting information or enhance it. The spuriousness of the designed accounting data made easy by the loopholes created by the erstwhile GAAP is the lens through which this paper views the impact of IFRS adoption on the value-relevance of accounting. To empirically test if the adoption of IFRS has improved the value-relevance of accounting information, this study assesses two major traits often claimed as the advantages of IFRS adoption over most GAAPs for the purpose of analysis – more disclosure under IFRS and the adoption of fair valuation measurement. Survey method was adopted to gather data for the analysis and a log-linear test was run. The study submits that IFRS adoption plays a significant role in enhancing the value-relevance of accounting information in Nigeria. However, the effect is impacted more by more disclosures required under IFRS than GAAP while fair value adoption has a lower influence. Nonetheless, the respondents significantly perceived that there is improvement in the value-relevance of accounting information since IFRS adoption. More so, an improvement by the government and relevant regulatory bodies to ensure wide adoption of IFRS will most likely improve its impact on the value relevance of accounting information. Hence, more measures should be put in place to ensure wider adoption of IFRS by affected entities.

late

REFERENCES

Adeyemi, S. B., & Fagbemi, T. O. (2011). The perception of ethics in auditing profession in nigeria. *Journal of Accounting and Taxation*, 5 (7), 146-157.

Akintoye, I. R. (2008). Efficient Market Hypothesis and Behavioural Finance: A review of Literature. *European Journal of Social Science*, 7 (2), 7-17.

Ali, A., & Hwang, L.-S. (2000). Country-Specific Factors Related to Financial Reporting and the value relevance of Accounting Data. *Journal of Accounting Research* (spring): 1-21

Amat, O., & Gowthorpe, C. (2002). Creative Accounting: Nature, Incidence and Ethical Issues. *Journal of Economic Literature* , 1-19. Retrieved July 2, 2014 from: <http://repositori.upf.edu/bitstream/handle/10230/1149/749.pdf?sequence>

Amat, O., Blake, J., & Dowds, J. (1999). The Ethics of Creative Accounting. *Journal of Economic Literature*. Retrieved July 2, 2014 from: <http://www.econ.upf.edu/docs/papers/downloads/349.pdf>

Anao, R. A. (2012). FRC Act and Nigeria Roadmap to IFRS - Implication for Accounting Education in Nigeria. Abuja: Financial Reporting Council of Nigeria.

Barth, M. E., Gomez-Biscarri, J., & Lopez-Espinosa, G. (2012). *Fair Value Accounting and Firm Valuation*. Retrieved July 2, 2014 from: <http://pendientedemigracion.ucm.es/centros/cont/descargas/documento18505.pdf>

Brochet, F., Jagolinzer, A., & Riedl, E. J. (2011). Mandatory IFRS Adoption and Financial Statement Comparability. *Harvard Business School Working Paper* . Retrieved: July 2, 2014 from: <http://www.hbs.edu/faculty/Publication%20Files/11-109.pdf>

Callao, S., Jarne, J. I., & La´inez, J. A. (2007). Adoption of IFRS in Spain: Effect on the comparability and relevance of financial reporting.

Journal of International Accounting, Auditing and Taxation , 16(2), 148-178.

Christensen, H. B., Lee, E., & Walker, M. (2007). Incentives or standards: What determines accounting quality changes around. *Manchester Business School - Research - Working Papers; no. 523* .

Copeland, R. (1986). Income Smoothing. *Journal of Accounting Research*, (Empirical Research in Accounting: Selected Studies): 101-116

Cunningham, G. M., & Harris, J. E. (2006). Enron and Arthur Andersen: The case of the Crooked E and the Fallen A. *Global Perspectives on Accounting Education*, 3, 27-48.

Devalle, A., & Magarini, E. O. (2012). Assessing the value Relevance of Accounting Data After the Introduction of IFRS in Europe. *Journal of International Financial Management and Accounting*, 21 (2), 85-119.

Effiok, S. O., & Eton, O. E. (2012). Creative Accounting and Managerial Decision on Selected Financial Institutions in Nigeria. *International Journal of Business Research and Management*, 3 (1), 35-47.

Hadi, M. M. (2006). Review of Capital Market Efficiency: Some Evidence from Jordanian Market. *International research of Finance and Economics* (3), 13-27.

Hitz, J.-M. (2005). The decision Usefulness of Fair Value Accounting - A theoretical Perspective. *Cologne Working Papers on Banking, Corporate Finance, Accounting and Taxation* , 1-40.

International Accounting Standards Board. (2008). *IAS 27 Consolidated and Separate Financial Statements*. Retrieved July 2, 2014 from: http://www.tagi.com/uploadfiles/ifrs_and_iasb_standards/ias27.pdf

Jain, V. (2012). An insight into the Behavioural Finance Models, Efficient Market hypothesis and its Anomalies. *Journal of Arts, Science and Commerce*, 3 (3), 16-24.

Jensen, M. C., & Smith, C. w. (1984). *The Modern Theory of Corporate Finance*. New York: McGraw-Hill Inc.

Jensen, R. E. (2007). Fair value accounting in the USA. In P. Walton, *The Routledge Companion to Fair Value and Financial Reporting*. Oxon: Routledge.

kepsu, M. (2012). *Earnings Management in the Process of Preparing Corporate Financial Reports*. Turku: Turku School of Economics.

Lee, E., Walker, M., & Zeng, C. (2013). Does IFRS Convergence Affect Financial Reporting Quality in China? *The Association of Chartered Certified Accountants Research Report* .

Mattessich, R. (2003). Accounting representation and the onion model of relity: A comparison with Baudrillard's orders of simulacra and his hyperreality. *Accounting, Organizations and Society*, 28(5) 443-470.

Nigeria, T. F. (2011). Financial Reporting Council of Nigeria Act. *Federal Republic of Nigerial Official Gazette* . Lagos: Federal Government Printer.

Nwaolisa, E. F., & Kasie, E. G. (2012). Efficient Market Hypothesis: A historic perspective (A study from Nigerian Capital Market). *Kuwait Chapter of Arabian Journal of Busines and Management Review*, 1 (8), 76-85.

Osayande, O. J. (2012). Financial Reporting Council (FRC): A vehicle for improving Corporate Financial Reporting in nigeria. Abuja, Nigeria: Financial Reporting Council of Nigeria.

Otusanya, J. O., & Lauwo, S. (2012). The Role of Auditors in the Nigerian Banking Crisis. *Accountancy Business and the Public Interest*, 9, 159-204.

Palepu, K. G., & Healy, P. M. (2003). *The Fall of Enron*. Retrieved April 1, 2012, from <http://ssrn.com/abstract=417840>.

Rajan, M. V., &Reichelstein, S. (2009). Depreciation Rules and the Relation between Marginal and Historical Cost. *jornal of Accounting Research*, 47 (3), 823-865.

Ryan, G. S. (2008). Fair Value Accounting: Understanding the Issues Raised by the Credit Crunch. *Council of Institutional Investors*. Retrieved July 2, 2014 from: <http://www.uic.edu/classes/actg/actg593/Readings/Fair->

Sanusi, S. L. (2010). "the Nigerian Banking Industry: What Went Wrong and the way forward". 1-23. Kano: Bayero University.

Smith, R. M. (2003). Transparency, Financial Accounting Information, and Corporate Governance. *FRBNY Economic Review* , 9(1), 65-87.

Sullivan, G. R. (2004). Enhancing Public Trust in the Accounting Profession: Using Professional Judgment Rather Than Personal Judgment in Resolving Accounting Ethics Dilemmas. Regent University Unpublished Doctoral Thesis.

Sum, S. (2012). *Latest Proposal to Regain Public Trust for Accounting Profession*. Retrieved September 2, 2012, from http://www.pkf-hk.com/pdf/Audit/Public_Trust_of_acct_professional.pdf

Wai, L. Y. (2008). Noise in Accounting Information: The Signal Detection Theory Perspective. *Int. Journal of Economics and Management*, 2 (1), 179-193.

Wu, J. S., & Zhang, I. X. (2011). *Accounting Integration and Comparability: Evidence from Relative Performance Evaluation around IFRS Adoption**. Retrieved July 18, 2013, from <http://www3.nd.edu/~carecob/MidwestResearchConf/Zhang.pdf>.

Wyatt, A. R. International Accounting Standards and Organizations: Quo Vadis? In F. Choi, *International Accounting and Finance Handbook*. New York: John Wiley and Sons.

Yang, Z., Rohrbach, K., & Chen, S. (2005). The Impact of Standard Setting on the Relevance and Reliability of Accounting Information: Lower of Cost or Market Accounting Reforms in China. *Journal of International Financial Management and Accounting*, 16 (3), 194-228.

Željana, A. B., & Klepo, T. (2006). Features of accounts manipulation in croatia. *Zb. rad. Ekon. fak. Rij*, 24 (2), 273-293.

ETHICS

IMPLICATIONS OF ACCOUNTANTS' UNETHICAL BEHAVIOR AND CORPORATE FAILURES –

Eshiet, U. E.

Faculty of Social and Management Sciences

Department of Accounting

Akwa Ibom State University

Obio Akpa Campus

Akwa Ibom State

Nigeria

Ueshiet2013@gmail.com

+2348028490973

Abstract:

Purpose/objective: Emphasis on short term profit and share prices as significant criteria for the determination of business success have led to the attrition of stakeholder trust and unlocked the doors for unethical conducts by professional accountants. This study recognized the morals, beliefs, practices, and the experiences of accountants in the global market place and led to the advancement of ethical practices that protect the interest of the stakeholders. This study was undertaken to encourage professional accountants to act ethically and in the interest of stakeholders.

Methodology/approach: A literature review of fifteen scholarly peer-reviewed journal articles on recent corporate scandals caused by unethical behaviors of corporate leaders and accountants was conducted.

Findings: (1) Unethical behaviors by accountants have unintended consequences on the stakeholders; (2) professional accountants and the accounting profession have suffered severe image damages as a result of unethical behaviors by corrupt accountants; (3) unethical behaviors by accountants significantly contributed to the global corporate scandals, the Nigerian banking sector reorganization, and the extinction of some global companies between 2002 - 2009;

(4) companies can survive ethical challenges if they embark on the correct remedial actions;

(5) audit committees oversight functions are critical in preventing corporate scandals;

(6) (un)ethical behaviors by accountants and organizational leaders is a tenable leadership theory.

Implications/research limitations: This study, grounded on the conceptual framework of business ethics, addressed the implications of unethical behaviors by accountants. This research investigated the consequences of unethical conducts by accountants and organizational leaders

using Tyco International scandal as a case study. Implications are that unethical behaviors by accountants have unintended consequences on the stakeholders. Also, unethical behaviors by accountants significantly contributed to the global corporate scandals, the Nigerian banking sector reorganization, and the extinction of some global companies from 2002 – 2009. For future research, more work should be done to incorporate other relevant studies into the literature.

Keywords Accounting profession. Ethical behavior. Nigerian banking sector

reorganization. Professional accountants. Tyco International. Stakeholders.

Introduction:

All business and financial transactions have economic and ethical implications. Consequently, every living person in the society is a stakeholder in such transactions. Wilcke's diary (as cited in Strider and Diala-Nettles, 2014) is in support of this assertion. This researcher and other notable scholars are in support of this philosophy as well. Recently, global organizations have placed a lot of emphasis on short term profits and share prices as the major determinants of business success. Professional accounting firms have closely collaborated with business leaders and compromised their ethical standards in return for huge monetary and financial gains. These have opened the doors for unethical practices by business leaders in general and professional accountants in particular. The end products of these unethical practices are corporate scandals, false accounting, forced mergers and acquisitions, the recent Nigerian banking sector reorganization, business closures and a host of other unintended consequences.

The universal quandaries discussed in this study were unethical practices by professional accountants from the year 2000 until the present. This study, grounded on the conceptual framework of institutional theory and business ethics, addressed the implications of unethical behaviors by professional accountants on the global market place. The research question investigated the consequences of unethical conducts by professional accountants and global organizational leaders using the Tyco International scandal as a case study. A literature review of fifteen scholarly peer-reviewed journal articles on recent corporate scandals caused by unethical behaviors of

corporate leaders and accountants was conducted. Results found that:

(1) unethical behaviors by accountants have unintended consequences on the stakeholders;

(2) professional accountants and the accounting profession have suffered severe image damages as a result of unethical behaviors by corrupt accountants; (3) unethical behaviors by accountants

significantly contributed to the global corporate scandals, the Nigerian banking sector reorganization, and the extinction of some global companies between 2002 - 2009;

(4) companies can survive major ethical challenges and scandals if they embark on the correct courses of remedial actions; (5) audit committees oversight functions are critical in preventing corporate scandals and failures; (6) unethical behaviors by accountants and organizational leaders is a viable and tenable leadership theory for organizations and their followers. This study was undertaken to encourage professional accountants to think and act ethically and in the interest of all stakeholders. For future research, more work should be done in order to incorporate other relevant studies into the literature.

Background of the study:

Historical summary of Tyco International:

Tyco was originally founded in 1960 by Arthur Rosenberg as an investment and holding company. In 1964, Tyco went public and strategically began a sequence of acquisitions. However, Tyco International Ltd. was organized under the laws of Switzerland. Tyco International, a Massachusetts corporation, was created in 1997 following acquisition of Tyco International by ADT Limited, a public company. ADT Limited was organized under the laws of Bermuda during which time ADT Limited changed its name to Tyco International. Following the board resolution on March 12, 2009, the company stopped to exist as a Bermuda corporation and continued to exist as a Swiss corporation. Tyco's International registered office is in Schaffhausen, Switzerland while its management office is located in Princeton, New Jersey,

U. S. A. Within a period of four years, Tyco had acquired sixteen companies, and the expansion strategy continued through 1982. Dennis Kozlowski started working for Tyco in 1975. Kozlowski found a

friend and mentor in the person of Joseph Gaziano, then the CEO. Gaziano

believed in and practiced extravagant lifestyle that was financed and sustained by resources owned by Tyco. Gaziano died in 1982 and was replaced by John F. Fort III. "Kozlowski, who had thrived under Gaziano, was forced to adapt to the abrupt change in leadership" (Boostrom, Ferrell and Ferrell, 2011, p. 1). Soon, Kozlowski was promoted to the position of president of Grinnell Fire Protection Systems Company, the largest segment in Tyco International.

From 1973 to 1982, the company grew from \$34 million to \$500 million in combined sales. Subsequently, the company was reorganized into three business divisions: electronics, fire protection and packaging. Tyco continued its expansion strategy through 1990's during which time it changed its name to Tyco International: clearly, a sign of its international presence. During the early 2000s, Tyco International had acquired over thirty major companies including CIT Group, Raychem and ADT. The antecedent of these unfortunate incidents was that L. Dennis Kozlowski was accused by the District Attorney (DA) of Manhattan of cheating on \$1 million in sales tax on the purchase of art. This accusation opened the doors for broader investigation by Tyco board of directors and the Manhattan DA. Following the investigations, L. Dennis Kozlowski and Mark H. Swartz were indicted on more than thirty counts of misconduct.

Problem and purpose of the study:

The universal quandaries discussed in this study were unethical practices by professional accountants from the year 2000 until the present. The research question investigated the consequences of unethical conducts by professional accountants in particular and global organizational leaders in general, using the Tyco International scandal as a case study. This study was undertaken to highlight the implications of unethical behaviors by professional accountants and to encourage professional accountants to think and act ethically and in the interest of all stakeholders.

A literature review of fifteen scholarly peer-reviewed journal articles on recent global corporate scandals caused by unethical behaviors of corporate leaders and professional accountants was conducted.

Conceptual framework:

This study was grounded on the conceptual framework of institutional theory and business ethics. This study was based on the notion that corrupt organizational leaders do not act independently. Rather, corrupt organizational leaders are aided and encouraged by close collaborations and compromise by corrupt professional accountants in return for huge financial and monetary gains. Professional accountants have responsibilities to create processes and internal controls so shareholders and stakeholders continue to trust and rely on their professions and to relate with them and their clients with confidence that are needed for efficient operations. Institutional theory, according to Greenwood and Suddaby's diaries (as cited in Strider and Diala-Nettles, 2014) was first summarized by Greenwood in 1957. Leicht and Fennell's diaries (as cited in Strider and Diala-Nettles, 2014) further opined that institutional theory requires organizations, their leaders, accountants, lawyers to act ethically with morals and attitudes forming the basis for professional standards. Besides, institutional theory examined economics as an informative model. Additionally, institutional theory is a suitable conceptual framework if the study of behavioral preferences is desired.

For many practical reasons, this researcher espoused the social constructivist worldview for this study. The social constructive worldview is very appropriate to qualitative studies if the researcher sought to appreciate the world in which the study partakers work and live in. The social constructivist worldview allowed for in-depth study of the experiences of each individual and led to a comprehensive representation of the formation and applications of values.

According to Ford and Lawler's diaries (as cited in Strider and Diala-Nettles, 2014), by taking into account the conducts and actions of study participants, the social constructivist viewpoint study the past and is highly recommended method if the study of leadership behaviors is desired.

Discussion:

Unethical behavior or events examined:

The unethical behavior or events under consideration at Tyco International can broadly be categorized into violations of trust and loyalty, stealing, fraudulent financial dealings and misuse of Tyco International funds for personal gain. The above unethical behavior or events at Tyco International were perpetuated by Dennis Kozlowski

(Chief Executive Officer, CEO) and Mark Swartz (Chief Financial Officer, CFO). Mark Swartz, as the CFO was supposed to be the embodiment of truth, honesty and trust and was responsible for the overall safeguard of Tyco International assets. But Mark Swartz turned out to be the architect, an accomplice and a collaborator of unethical financial dealings at Tyco International. These unethical financial dealings caused the iconic corporate scandal at Tyco International and almost led to the extinction of Tyco International. The lavish and extravagant life style of Dennis Kozlowski, financed by the wasteful spending and unauthorized loans from Tyco International resources were very glaring: with almost a half-billion in earnings, a \$31 million Fifth Avenue apartment, expensive toys, a vintage yacht, a Renoir and a Monet, a \$6,000 corporate funded glided shower curtain and an ice sculpture of David peeing Stolichnaya. But why did the spending and the loans continue for so long? With a corporate governance system composed mainly of trusted friends and allies with similar questionable and unethical behaviors, concealment of the spending and unauthorized loans was not only possible; it was encouraged by the leadership of Tyco International with collaborations from Mark Swartz (CFO) and Deloitte & Touche, the

professional accounting firm for Tyco International. Mark Swartz (CFO) had very strong connections with Deloitte & Touche. Mark Belnick (general counsel) also had strong ties with Paul, Weiss, Rifkind, Garrison & Wharton. Boostrom, Ferrell and Ferrell (2011) posited that the kitchen cabinet directors of Tyco International under Kozlowski were charged with the responsibility of safeguarding Tyco's shareholders through the discovery of questionable inappropriate and unethical issues. But did they? No. Rather, through collaborations and compromises from the CFO and the accounting firm, Tyco International almost got wiped out from the global market place.

Precisely on September 12, 2002, former CEO, L. Dennis Kozlowski and former chief financial officer (CFO), Mark H. Swartz, all of Tyco International were paraded in handcuffs on national television following their arrests and being charged for misappropriating more than \$170 million from Tyco International. The duo was also indicted for stealing more than \$430 million through fraudulent sales of Tyco International stock without the knowledge of Tyco International

stockholders. Dennis Kozlowski (CEO) was accused of granting illegal loans to the tune of \$106 million to employees. Mark Swartz (CFO) was accused of falsification of loan documents in the amount of \$14 million. All these fraud, stealing and unethical practices happened under the watchful eyes of Deloitte & Touche, the professional accounting firm for Tyco International. Given all these, the academic question to ask is: was Deloitte & Touche incompetent, an accomplice or a collaborator? The opinion of this author is that the accounting firm of Deloitte & Touche was both an accomplice and a collaborator in the Tyco International scandal.

Reflection on ethical standards:

Is it really true that the term 'business ethics' as used within and outside the United States is an oxymoron? Is telling a lie always wrong?

Do ethical business practices by professional accountants impede successful businesses? Should we as individuals make efforts to do what is right? Why should we be ethical? What is in there for someone who is ethical? These questions have troubled contemporary ethicists and many at times have worsened within individual and corporate jurisdictions. It is a generally accepted fact that ethics is valuable especially to professional accounting firms. Evidence also abound that most global professional accounting firms merely adopt standards so as to comply with some laws or regulations that carries some form of punishment or sanction for noncompliance. Corporate scandals, like that of Tyco international have serious unintended consequences on the organizational shareholders, stakeholders, followers, leaders and the global market place.

Ethical leadership is embedded in ethical standards. This is also true and applicable to global accounting firms. According to Freeman (n.d.), it is incumbent on the leader to strike a balance between being a good leader and a morally good person. Additionally, ethical leaders are responsible to the shareholders, subordinates, stakeholders, customers, suppliers and the community in which they operate in. Freeman further posits that primacy should not only be given to insiders, but primacy should also be extended to stakeholders since their actions may potentially have effects on the organization as well. Many scholars including this author are in agreement with Freeman's

assertion above. Moral and ethical values of leaders and supervisors play a very critical role (Miao, Newman, Yu and Xu, 2013) in regulating organizational behavior. Unethical perspectives of leadership, like the scandal of Tyco International, more often than not result in unintended negative consequences for the organization. It is the opinion of this paper that the board at Tyco International encouraged the unethical behaviors of the leadership of Tyco. The board of directors at Tyco International failed in their responsibilities in ensuring that Kozlowski and his team did not expose the organization to all the unnecessary risks.

This paper also opined that if Mark Swartz (CFO) and the accounting firm of Deloitte & Touche did not compromise or collaborated with the leadership of Tyco International, the fraud, stealing and the subsequent scandal at Tyco International would have been minimized or prevented.

In 2005, the Nigerian financial sector was in serious state of distress. According to Soludo diary (as cited in Oghojafor and Adebisi, 2012), as of 2004, there were 89 banks with approximately 3,382 branches located in urban areas with extreme operational deficiencies including illiquidity, insolvency and overreliance on public sector deposits and trading from foreign exchange. To restore public confidence in the financial sector, the Central Bank of Nigeria (CBN) headed by Professor Charles Soludo, resorted to mergers and acquisition strategy. At the end, 24 Nigerian banks survived with a new requirement to maintain a minimum capital base of 25 billion naira. The root causes of the near collapse of the Nigerian banking sector in 2004 were unethical conducts by the leaders including the chief financial officers and compromises and collaborations by accounting firms in charge of the affected Nigerian banks. The 2004 Nigerian banking sector distress was yet another painful reminder of the Tyco International scandal. It is the opinion of this paper that the Nigerian banking sector is not out of the wood yet especially with the global decrease in crude oil and oil prices.

Influence of leadership:

Leadership styles exert a lot of influence on organizational performance and outcomes. Transformational and servant leadership styles are two of the most tenable and very useful leadership theories in practice. Servant leadership (Choudhary, Akhtar and Zaheer, 2013) embarks on very useful behavioral and emotional features for the

benefit of the organization. Choudhary et al. further posit that transformational leadership has more influence on organizational learning than Servant leadership. Despite the slight similarities between the two

concepts, this paper is of the opinion that the leadership, the accountants and the accounting firms for the companies under study did not embrace any of these two leadership concepts.

Which leadership style is best suited for organizational performance is beyond the scope of this paper. However, leadership at Tyco International, accounting firm of Deloitte & Touche did not encourage intellectual stimulation through inspiration: a cardinal feature of the transformational leadership. Also, leadership at Tyco International, Deloitte & Touche did not motivate, guide, offer neither hope nor provide a caring experience for their subordinates and followers as postulated by the servant leadership theory. The unethical and corrupt behaviors of Kozlowski, Swartz and their team exposed the firm to unnecessary risks and the negative outcomes that ensued. So, this paper is of the opinion that the unethical behavior of Tyco International leadership, collaborations by Mark Swartz, Tyco's board ineptness, lack of effective oversight by the audit committee and the compromise and collaborations from Deloitte & Touche jointly and negatively influenced the organizational culture of Tyco, hence the scandal and the near extinction of Tyco International. Kozlowski started working with Tyco after (Boostrom, Ferrell and Ferrell, 2011) short periods with SCM Nashua corporations. At Tyco, Kozlowski found a friend and mentor in the person of Joseph Gaziano, then CEO of Tyco. Gaziano, according to Boostrom et al. had a very lavish lifestyle: company jets, extravagant vacations, company cars and country club memberships-all financed by Tyco resources. This paper is of the opinion that Gaziano, as a friend and mentor, exerted tremendous negative influence on Kozlowski. Kozlowski followed the footsteps of Gaziano and was briefly forced to adapt to leadership of style of John F. Fort III. Kozlowski lifestyle was mirrored after that of Gaziano, hence the unnecessary risks that he exposed the firm to and the near extinction of Tyco International.

Similarly, Kozlowski exerted unethical influence on Mark Swartz, the CFO. Kozlowski was the CEO and Swartz reported to him. It very

possible that most of the accounting frauds were crafted and designed by Swartz while the final approval rested with the CEO-Kozlowski. Most of the directors at Tyco International were trusted friends of Kozlowski. To make matters worse, majority of these directors had worked under Kozlowski for ten years or more. They were very familiar and negatively influenced by the management style of Kozlowski. Show me your friend and I will tell you who you are. Apparently, the directors exhibited unethical values and they encouraged the unethical behaviors of Kozlowski and Swartz. Those directors and other stakeholders that opposed Kozlowski and his cabal were shown the door: Jeanne Terrile of Merrill Lynch was a victim. This was a clear signal that Kozlowski did not want people that were honest, trustworthy and of high integrity around him. So, from the CEO to the CFO to the directors, moral values were lacking and unethical conducts became the norm rather than the exception. Due to the trickle-down effect, the employees of Tyco International were negatively impacted by the unethical behaviors from the leaders and top management. Kozlowski had zero tolerance for whistle blowers. So for Tyco employees, it was put up and shut up. The subordinates at Tyco had no alternatives except to be unethically influenced by Kozlowski and his corrupt kitchen cabinet.

The mergers and acquisition strategies between 2004 and 2005 adopted by Professor Charles Soludo needed a boost by the CBN in 2008. "The effect in the capital market defiled all measures put in place by regulators to boost the market during the year" (Osuala, Nto and Akpan, 2012, p. 101). This author agrees. Consequently, in 2009, the CBN under the leadership of Mallam Sanusi Lamido Sanusi removed the leadership Oceanic Bank International Plc., Intercontinental Bank Plc., Union Bank Plc., Afribank Plc. and FinBank Plc.

The above mentioned bank leaders were corrupt and inept with striking similar unethical conducts as the leaders at Tyco International. This paper opined that the corrupt and unethical conducts of these Nigerian bank leaders were encouraged and sustained by the chief financial officers and the professional accounting firms in charge of these defunct banks. Question is: why were these corrupt professional accountants not punished alongside with the bank leaders? Or were

they? The collapse of Enron Corporation was yet another bad example of unethical behavior by global corporate leaders, accountants and professional accounting firms.

Enron Corporation was a conglomerate by all standards with reported revenues above one hundred billion in 2000. However, there were serious allegations during the 1990's involving Enron and Arthur Andersen, its accounting firm. These allegations as were later proved to be true, involved crooked accounting procedures with fraudulent implications. The share price of Enron declined from above \$90 per share to just nickels and dime. The scandal led to the collapse of Enron Corporation and the dissolution of Arthur Andersen which was one of the largest accounting firms in the world at that time. "The financial collapses of Enron had substantial and far-reaching ramifications throughout the financial investment field, tax compliance professions and the accounting profession" (Bottiglieri, Reville and Grunewald, 2009, p. 1). This paper agrees. Due to the unethical conducts of the leaders at Enron, Enron's corrupt and compromising professional accountants, over twenty thousand workers became unemployed, the global market place lost billions of dollars, Jeff Skilling, the former CEO of Enron is serving jail time and his son was found dead, former Enron CFO is also behind bars and above all, Ken Lay, the former CEO of Enron committed suicide. Yet another painful reminder of the unintended consequences of unethical conducts by organizational leaders, professional accountants and professional accounting firms.

Social responsibility responses: Actual and appropriate:

It is difficult to have a discussion about recent unethical conducts by professional accountants and the subsequent corporate scandals without references to social responsibility implications. Some authors including (Lauesen, 2013) are in doubt whether the corporate social responsibility (CSR) movement had enough weight to stop another financial crisis. This paper agrees with the opinion of Lauesen above. However, with stringent legislations such as the SOX, further global financial crisis and scandals can be minimized if not prevented. Various social responsibility responses trailed the unethical behaviors of Mark Swartz, the corrupt accountants under study and the associated professional accounting firms. Prominent among the actual responses were tarnished image and reputation, loss of faith by

shareholders and stakeholders. Leaders and practitioners must understand and be conscious of how leadership ethical behaviors can impact the ethical and social responsibility of the organization and its followers, Groves and LaRocca (2011). Leaders with singular focal point of shareholder wealth maximization, financial performance and personal wealth (Groves et al.) usually exhibit corrupt subordinate behavior and ethically reproachful changes in their organizations. This paper is in agreement with the above assertions.

Tarnished image and reputation of the accounting profession:

Since the collapse of Enron, and other iconic corporate scandals at Tyco International, WorldCom, AIG, Arthur Andersen, the Nigerian banking sector reorganization and a host of others, the accounting profession has been under tremendous scrutiny by the governments, regulatory authorities, shareholders and stakeholders. This should not come as a surprise given the unintended consequences of unethical conducts by corporate leaders and their professional accountants. There is an important correlation between ethical stewardship and trust. Given the

recent numerous corporate scandals, there exist a gap of trust between stakeholders and the accounting profession. This tarnished image undermines stakeholders' commitment, hinders wealth creation and increases transaction costs for global organization (Caldwell, Hayes and Long, 2010). This paper is in agreement with this assertion. Also, the Sarbanes-Oxley Act of 2002 (SOX) was a direct offshoot of unethical conducts by accountants. According to Knott and Steube (2014), the SOX was aimed at curtailing and punishing corporate and accounting fraud, protecting the interest of employees and stakeholders with extreme penalties for offenders.

Tarnished image and reputation of Tyco International and other scandalous companies:

While at the helm of Tyco International, all Swartz, Kozlowski and Deloitte & Touche cared about was their personal wealth. The short-lived "excellent" financial performance and shareholders return were fake and window-dressing. They did not care about the welfare of the shareholders, employees and other stakeholders, hence their numerous social responsibilities failures and shortcomings. To stop their employees from whistle blowing, Swartz and Kozlowski offered

various “loan forgiveness” to the tune of \$106 million and relocation programs to employees.

Noticeably, one of the most ardent supporters of Kozlowski and Swartz, David Kaplan is aware of how socially irresponsible Kozlowski and Swartz were when he noted that “if avarice alone were grounds for incarceration, much of Wall Street would be doing time.”

(Kaplan, 2009, p. 15). According to Palmer’s diary (as cited in Stephens, Vance and Pettegrew, 2012), leaders must set the moral and ethical character for the organization. The social responsibility of a firm demands that leaders of the organization should: maximize the wealth of the firm, set the moral tone for their companies, and practice what they preach, be of high ethical values and also be socially responsible to its shareholders, its customers, employees and the community in which they operate.

Mark Swartz, Tyco leadership, Enron leadership, Arthur Andersen, leaders of the defunct Nigerian banks, their accountants and the accounting firms did none of these, hence the tarnished image, loss of confidence by shareholders and stakeholders and other unintended social responsibility consequences that followed. Restoring tarnished corporate image is many at times challenging to organizations (Eweje and Wu, 2010). This author agrees with the opinion of Eweje and Wu. Consequently, it is better for global organizations to demonstrate corporate social responsibilities at all time. Tyco International learned the hard way and survived major image damage. Enron, Oceanic Bank, Afribank, Bank PHB, Spring Bank and others were not so lucky, hence their extinction from the global market place.

Related cultural, environmental, and legal implications:

Tyco was born in Switzerland, got married to a Bermudan and changed its name to Tyco International and adopted United States as its official residence. So, the scandal at Tyco International was not without cultural, environmental and legal implications. The same were true for other scandalous global companies under study.

Cultural implications:

Decisions taken and unethical practices by these global companies were bound to affect their international partners as well and it did. Their shareholders, employees, stakeholders, suppliers, customers came from different parts of the globe. Hence, the effects of their scandals were felt globally. Besides the negative global financial impacts, investors, (especially foreign) started losing

confidence in these respective companies. The image damages done these firms as a result of the scandals extended across national boundaries. Ethics, including business ethics is a subjective concept. What is ethical in one country may be unethical in another country. Our morals also differ depending on cultural and national beliefs.

So, it is the opinion of this paper that some of the unethical behaviors that confronted the leadership of Tyco International, Enron, Oceanic Bank, Afrikkbank, Bank PHB, Spring Bank and others were culturally driven. The multi-cultural and multi-national backgrounds of these global companies impacted the ethical behavior and their organizational cultures.

Environmental implications:

Firms do not exist in a vacuum. Operational activities of firms are associated with environmental impacts as well. Social responsibility of a business includes taking care of the environment in which the business operates. Given the scandal, theft, stealing and unethical business practices at Tyco International and other global companies under study, the environment was neglected while their leaders pursued their extravagant self- interests.

Legal implications:

The unethical behaviors of these corporate leaders and their accountants were criminal with some serious legal consequences. Generally, in the legal system, you are innocent until proven guilty. Most if not all of the unethical leaders and accountants had some allegations leveled against them. Most of them went through the legal process. Most of them were found guilty and punished for the crimes they committed. But the academic question is: have we learned from the past mistakes of these corrupt corporate leaders and professional accountants? If so, how did Bernie Madoff cheat billions of dollars from the stakeholders? How was the 'London Whale' at JP Morgan able to expose the company and investors to significant losses? The legal implications of these corporate scandals are clear: the global market place and the investing public want to rid the global market place of corrupt leaders and accountants. The global market place legal system is ready to restore investor's confidence in the global market place firms. The battle line has been drawn. Time will tell who wins this battle.

Impact on stakeholders:

Tyco International and other global organizations under study, their shareholders, followers and the global market place can benefit from leaders and accountants with moral and ethical behaviors. However, the reverse was true in their cases. The affected companies, their stakeholders and employees were economically and financially disenfranchised. Though consolidated earnings, share prices, cash flow projections for these scandalous companies tend to astronomically increased, however, these gains all disappears when scandals set in. Besides the financial and economic losses, these leaders, accountants, shareholders and followers suffered severe psychological and emotional harm. Some of these leaders and accountants are serving time in jail. The global market place suffered huge financial losses as well.

Outcome of events with a comparison of the consequences:

The unethical business practices of Tyco International under Kozlowski had major outcome and consequences. Tyco International scandal of 2002 had snowball negative effects within and without Tyco International. As of January 2002, Tyco stock was trading at \$60 per share. In December of 2002, Tyco share value dropped by a whopping (70%) and traded at \$18 per share: an enormous financial loss to Tyco shareholders and the global economy. Sadly enough, most of the employees of Tyco were also shareholders of Tyco International. Tyco International suffered severe damage to its corporate reputation. Still, professionals and their related associations like Certified Public Accountants suffered image damages as well. Ken Lay of Enron committed suicide. Leaders of AIG, Lehman and Bear Stearns caused the extinctions of their former global companies. Jeffrey Skilling also of Enron is serving long time behind bars. Bernie Ebbers of WorldCom is also serving long jail sentence. The corporate leaders of Oceanic Bank, Bank PHB, Afribank and others are no more at the helms of these defunct companies.

Also, most of their ill-gotten wealth has been forfeited by the government and billions of naira will have to be refunded by these corrupt leaders as well. However, in the Nigerian banking sector reorganization, punishments were not meted out to the corrupt accountants that aided and encouraged these bank failures. Or were

they punished? All these leaders and their respective firms have something in common: their unethical behaviors led to the corporate scandals and subsequent extinction of their companies. However, Tyco International survived the scandal and is recovering. This is a clear indication that companies can survive major ethical challenges (Boostrom, Ferrell and Ferrell, 2011) and scandals if they embark on the correct courses of remedial actions. Tyco International did just that and it is well on its way to full recovery from the scandalous ethical practices of its past leaders.

Fairness of punishment:

Following one mistrial, Kozlowski was convicted for a series of felonies and sent to prison for an indeterminate period of eight to twenty-five years. The trial, sentencing and the punishment meted out to Kozlowski and Swartz were controversial. Some critics including Kaplan argued that the punishment meted out to Kozlowski for his crimes was too stiff. "If avarice alone were grounds for incarceration, much of Wall Street would be doing time" (Kaplan, 2009, p. 15). On the contrary, Stephens, Vance and Pettegrew (2012) and this author disagree with Kaplan's assertion. Based on the crimes that Kozlowski and his cabal committed, the punishment given to them was fair. In deciding the punishment for the crimes that Kozlowski and his cabal committed at Tyco, the legal system, in my opinion also considered punitive damages for the serious harm done to Tyco, its shareholders, and the global economy.

Also, the corporate leaders of Oceanic Bank, Bank PHB, Afribank and others are no more at the helms of these defunct companies. Also, most of their ill-gotten wealth has been forfeited by the government and billions of naira will have to be refunded by these corrupt leaders as well.

The legal system was desirous of zero tolerance for the types of crimes committed by these corrupt corporate leaders and accountants. Which form of punishment will compensate for the financial, physical, psychological, economic and mental harm that these scandals caused to the victims? To my critics; is the harsh punishment responsible for the unrepentant attitude of Kozlowski after being a prisoner for a long time now? Was Ken Lay of Enron fair to himself when he committed suicide following his unethical behavior? Should we not allow the legal system and process (including clemency) a fair chance to work assuming that these corrupt leaders and accountants will repent and

be of good behavior? Can bribery, corruption allow the legal system in Nigeria to work as is the case in advanced countries such as U. S. so that wrongdoers and corrupt corporate leaders and accountants pay for their crimes? Have we learned any lessons from the Tyco incidents? My educated answer is probably no. Bernie Madoff cheated billions from stakeholders after the sad incidents at Tyco. At J. P. Morgan, "London Whale" was able to expose the company and investors to considerable losses following the Tyco scandal. I am of the same opinion with Stephens, Vance and Pettegrew (2012) that we need to concentrate on the moral failures that have led to these unethical behaviors rather than focusing on the rule of law including fairness of punishments. By focusing on and criticizing the punishment given to these corrupt corporate leaders and accountants, we are in effect focusing on the rule of law. This is counter-productive and will not help remedy the current ethical challenges that the global market is facing.

Recommendations:

The impact of unethical behavior by organizational leadership can have tremendous unintended consequences on the organization, shareholders, followers and the larger global market place. Ethical leadership is embedded in ethical standards. According to Freeman (n.d.), it is incumbent on the leader to strike a balance between being a good leader and a morally good person. Additionally, ethical leaders are responsible to the shareholders, subordinates, stakeholders, customers, suppliers and the community in which they operate in. Freeman further posits that primacy should not only be given to insiders, but primacy should also be extended to stakeholders since their actions may potentially have effects on the organization as well. Many scholars including this author are in agreement with Freeman's assertion above.

Moral and ethical values of leaders and supervisors play a very critical role (Miao, Newman, Yu and Xu, 2013) in regulating organizational behavior. Unethical perspectives of leadership,

like the scandal of Enron, Tyco International, Oceanic Bank, Bank PHB, Afribank and others more often than not result in unintended consequences for the organization. The board of directors at these

scandalous companies failed in their responsibilities in ensuring that their corporate leaders and accountants did not expose their organizations to the unnecessary risks. Also, the board must adopt a system whereby management is not evaluated, rewarded financially and subsequently promoted based on short-term profits. Management should be evaluated, rewarded financially and promoted based on short-term profits, long-term profits and for upholding and encouraging ethical standards. Practitioners have a duty to adopt one or a combination of the available tenable leadership theories that promotes ethical behaviors and concern for shareholders and subordinates. The national professional accounting associations must ensure that professional and practicing accountants undergo yearly training and retaining on ethics as part of their membership renewals. The global market witnessed and was victimized by

the unethical corporate structure practiced by these unethical leaders and accountants under study. Organizational boards of directors also have an obligation not to allow a decentralized corporate system in their organizations. The corporate audit committees must ensure that they provide and execute their oversight functions effectively to avoid a repeat of these scandals and corporate extinctions.

Academics, also have a duty to safeguard the global market place from total collapse. Within the academics, more studies and findings are needed in order to solve some of the challenges facing the global market today. As a word of caution: academics also need to be aware of the fact that ethics is a subjective concept and differs across national boundaries. Thus, what is illegal in Canada may be perfectly legal in Britain. Academics also must ensure that ethics are included in their curriculum. Academics must not relent in teaching ethics to the students.

Globally, in terms of ethical values, students are seriously deficient. Surveys and reports on ethical values of today's students are very troubling. Stephens, Vance and Pettegrew (2012) are of the opinion that the ethical behaviors of today's youth (students) are not in harmony with the current professional or leadership needs. I agree. We as academics can teach all the ethical values that we know to our students. However, the ultimate decision of becoming exemplary leaders of tomorrow is a personal choice. Habits of

dishonesty: stealing, cheating and lying are very rampant among students. An exemplary leader must be honest, trustworthy and of high personal integrity. As our future leaders, students must be willing and ready to hold people accountable whenever they are not doing the right thing. Making ethical values the foundation stone of educational career, will better prepare our youths for a career as an ethical, efficient and effective leader tomorrow.

Limitations:

The author cautions that this study should be viewed and understood in the light of its limitations. Despite the fact that this study was conducted in an efficient manner, the scholarly peer-reviewed studies used for this case study were limited to only fifteen that were published in English language. So to guide future scholars in their studies, more work should be done to

incorporate other relevant studies into the literature. Incorporating more and other relevant studies into the literature is an excellent method of proving or disproving the findings of the current study.

Conclusion:

All business and financial transactions have economic and ethical implications. Consequently, every living person in the society is a stakeholder in such transactions. Recently, global organizations have placed a lot of emphasis on short term profits and share prices as the major determinants of business success. Professional accounting firms have closely collaborated with business leaders and compromised their ethical standards in return for huge monetary and financial gains. These have opened the doors for unethical practices by business leaders in general and professional accountants in particular. The end products of these unethical practices are corporate scandals, false accounting, forced mergers and acquisitions, the recent Nigerian banking sector reorganization, business closures and a host of other unintended consequences.

The universal quandaries discussed in this study were unethical practices by professional accountants from the year 2000 until the present. This study, grounded on the conceptual framework of institutional theory and business ethics, addressed the implications of unethical behaviors by professional accountants on the global market place. The research question investigated the consequences of unethical conducts by professional accountants and global

organizational leaders using the Tyco International scandal as a case study.

In conclusion, this study found that: (1) unethical behaviors by accountants have unintended consequences on the stakeholders; (2) professional accountants and the accounting profession have suffered severe image damages as a result of unethical behaviors by corrupt accountants; (3) unethical behaviors by accountants significantly contributed to the global corporate scandals, the Nigerian banking sector reorganization, and the extinction of some global companies between 2002 - 2009; (4) companies can survive major ethical challenges and scandals if they embark on the correct courses of remedial actions; (5) audit committees oversight functions are critical in preventing corporate scandals and failures; (6) unethical behaviors by accountants and organizational leaders is a viable and tenable leadership theory for organizations and their followers.

The impact of unethical behavior by organizational leadership can have tremendous unintended consequences on the organization, shareholders, followers and the larger global market place. Ethical leadership is embedded in ethical standards. It is incumbent on the leader, the accountant and the professional accounting firm to strike a balance between being a good leader or accountant and a morally good person. Additionally, ethical leaders are responsible to the shareholders, subordinates, stakeholders, customers, suppliers and the community in which they operate in. Primacy should not only be given to insiders, but primacy should also be extended to stakeholders since their actions may potentially have effects on the organization as well.

References:

- Boostrom, R., Ferrell, O. C., & Ferrell, L. (2011). Tyco International: Leadership crisis. *Daniels Fund Ethics Literature*. 1-9.
- Bottiglieri, A. W., Reville, P. J. & Grunewald, D. (2009). The Enron collapse- The aftershocks. *Journal of Leadership, Accountability and Ethics*. 1-9.
- Caldwell, C., Hayes, L. A. & Long, D. T. (2010). Leadership, trustworthiness, and ethical stewardship. *Journal of Business Ethics*, (96), 497-512. doi: 10.1007/s10551-010-0489-y
- Choudhary, A. I., Akhtar, S. A. & Zaheer, A. (2013). Impact of transformational and servant leadership on organizational performance: A comparative analysis. *Journal of Business Ethics*, (110), 433-440. doi: 10.1007/s10551-012-1470-8
- Eweje, G. & Wu, M. (2010). Corporate response to an ethical incident: The case of an energy company in New Zealand. *Business Ethics: A European Review*, (19) 4, 379-392.
- Freeman, R. E. (n.d.). Stakeholder theory of the modern corporation. Retrieved from: www.academic.udayton.edu/lawrenceulrich/StakeholderTheory.pdf
- Groves, K. S. & LaRocca, M. A. (2011). An empirical study of leader ethical values, transformational and transactional leadership, and follower attitudes towards corporate social responsibility. *Journal of Business Ethics*, (103), 511-528. doi: 10.1007/s10551-011-0877-y
- Kaplan, D. A. (2009). Koz makes his case. *Fortune*, (160) 11, 14-16.
- Knott, C. L. & Steube, G. (2014). Accounting compensation modeling using the analytic hierarchy process supporting the Sarbanes-Oxley Act. *The Journal of Applied Business Research*, (30) 2, 599-604.
- Lauesen, L. M. (2013). CSR in the aftermath of the financial crisis. *Social Responsibility Journal*, 9 (4) 641-663.

- Miao, Q., Newman, A., Yu, J. & Xu, L. (2013). The relationship between ethical leadership and unethical pro-organizational behavior: Linear or curvilinear effects? *Journal of Business Ethics*, (120), 641-653. doi: 10.1007/s10551-012-1504-2
- Oghojafor, B. E. A. & Adebisi, S. A. (2012). Evaluating mergers and acquisition as strategic interventions in the Nigerian banking sector: The good, bad and the ugly. *International Business Research*, (5) 5, 147-154. doi: 10.5539/ibr.v5t5p147
- Osuala, A. E., Nto, P. O. & Akpan, S. F. (2013). The information content of sudden removal of corporate chief executives-Evidence from the Nigerian banking sector. *International Journal of Economics and Finance*, (5) 8, 101-107. doi: 10.5539/ijef.v5n8p101
- Stephens, W., Vance, C. A. & Pettegrew, L. S. (2012). Embracing ethics and morality. *CPA Journal*, 82 (1), 16-21.
- Strider, S. H. & Diala-Nettles, I. S. (2014). Ethical business decisionmaking considering stakeholder interest. *International Journal of Marketing and Technology*, (4) 1, 215-234.

ETHICAL ISSUES ABOUT CREATIVE ACCOUNTING: THEORETICAL AND PRACTICAL PERSPECTIVES

Fadiran, TaiwoPhebe
BSc,MBA,MSc. Ph.D., ACTI,FCA
Department of Accounting
AdekunleAjasin University
Akungba-Akoko, Ondo State

Alaka, Abayomi Ambali, Ph.D.
Technical and Education Department
ICAN, Lagos Nigeria

Abstract

Accounting possesses some qualities of science and some of art. The accountant, in applying his creativity skill while reporting the activities of his firm, is allowed to choose accounting bases he considered most suitable. However, there is lack of consensus on whether creative accounting (CA) is ethical or not. The objective of this study is to determine when CA becomes unethical and deceptive thus identify areas to streamline accounting principles and rules to reduce diversities of professional judgment in financial reporting. Content analysis of annual reports (AR) of Nigerian banks was carried out through disclosure index from 2000-2011. The scores in mandatory disclosure are high while those of voluntary disclosure are low and the scores rarely change for the twelve years. A few of the banks changed their account format in periods when they have negative net assets. The formats adopted were prescribed by CAMA and disclosure regulation did not specifically require disclosure of net assets. Hence, the concealment of negative net assets by the banks is creativity theoretically while in practice it could be termed unethical. Just as the introduction of uniform accounting date corrected a number of window dressing by Nigerian banks; there is the need to specify account format for entities in the same industry. A review of disclosure regulation on information content of AR is necessary because the minimum disclosure required by regulation is becoming highly insufficient to meet stakeholders' need. Creative accounting cannot be eliminated because even in highly regulated accounting environment, a great deal of flexibility is still allowed. Methods employed are changing with change in regulations as new standards open new opportunities or avenues; therefore, surveillance functionaries should be proactive in curbing abuse of accounting policy choice and manipulation of transactions.

Keywords: Ethical Issues, Creative Accounting, Nigerian Banks, Account Format, Disclosure Regulation.

Word Count: 291

1.0 INTRODUCTION

Creative accounting and ethical issues arising from it are more relevant to financial reporting. The need for financial reporting and disclosure arise from agency relationship and its associated problems. The relationship between management and shareholders of a company is a typical example of principal-agent relationship. The key features of the relationship among others include: conflict of interests and information asymmetry in form of hidden action and hidden information with consequential effect of moral hazard and adverse selection. According to Akenbor and Ibanichuka (2012), conflict of interests among different stakeholder groups is the root cause of creative accounting. This is particularly a serious issue and of concern to capital market regulators. Hence, regulatory measures are put in place to alleviate information problems, protect investing public and restore their confidence in the market.

Financial scandals are on the increase across the globe and Nigeria is not exempted from this menace. This is pointing to the fact that corporations are not adhering to rules and regulations put in place in this regard. One of the avenues by which corporation circumvent regulatory controls is through the abuse of creative accounting. There are a lot of debates in the literature as to the exact meaning of creative accounting, whether it is legal or illegal and whether it ethical or unethical. This paper examines issues relating to creative accounting from theoretical and practical perspective to determine its legality or otherwise and establish when it becomes unethical.

The rest of this paper is divided into four sections. The next section presents the literature review highlighting the theoretical positions, methodological issues and empirical perspectives to creative accounting. The methodology adopted in the study is presented in section three while section four presents the findings of the study. The paper ends with concluding remarks and recommendations in the last section.

2.0 LITERATURE REVIEW

2.1 Accounting as a Discipline, Its Objectives and Characteristics

It has been a controversial issue whether accounting as a discipline is an Art or a Science. To be able to take a position on this issue, it is essential to examine the definitions of 'Art', 'Science' and Accounting.

Art has been commonly described as a body of human creations that represent real things. Art is basically creating something that you can call yours like a written paper or art piece. Creativity and skills are important components of art.

Science has been described as any systematic knowledge or practice. It is an organized body of knowledge that is derived from observations and can be verified or tested by further investigation. Science can also be regarded as knowledge attained through study or practice or as knowledge covering general truths of the operation of general laws, especially as obtained and tested through scientific method and concerned with the physical world.

The American Institute of Certified Public Accountants (AICPA) defined accounting as "the art of recording, classifying and summarizing in a significant manner and in term of money, transactions and events which are in part, at least of a financial character and interpreting the result thereof." The American Accounting Association sees accounting as "the process of identifying, measuring and communicating economic information to permit informed judgments and decisions by users of the information"

Given the definitions above, it is glaring that accounting possesses some of the characteristics of both Art and Science. Like any science, it is based on many rules, principles, concepts, conventions and assumptions. It is an organised body of knowledge and could be verified. Scientific procedures of observation, investigation and identification through testing and collection of data are employed in accounting. Accounting could also be described as Art because it can be learnt by practice and creativity and skills are part of the discipline. This is why Morgan (1988) described accountant as subjective constructors of reality. Hence, one can safely conclude that accounting as a discipline is an inexact science and inexact art.

According to Glautier and Underdown (2001), the primary objective of financial reporting is to communicate economic measurement of and information about resources held by entity and performances of the reporting entity, useful to those having right to

such information. The Financial Accounting Standards Board (FASB) states three objectives of financial reporting. These are: provision of information useful in making investment and credit decisions, provision of information useful in assessing cash flow prospects; and provision of information about business resources, claims to those resources and changes in them.

To satisfy the stated objectives, there are a number of primary decision-specific attributes which accounting information should possess among which are: relevance and reliability (Needles and Power, 1998). These are joint attributes; as relevant information is of little value if it cannot be relied upon. Reliability is the extent to which information is verifiable, representationally faithful, and neutral. This implies that the accounting information that is presented is complete (nothing significant missed out) and capable of being verified by independent parties. Reliability also required that the information must be free from bias. Implying that, accounting information should convey information about entity's activity as faithfully as possible without influencing anyone in a specific direction.

To ensure verifiability aspect of reliability, statutory audit of firms' financial statements by external auditors has been prescribed by accounting and regulatory bodies. Faithful representation and neutrality is ensured through application of generally accepted accounting principles (GAAP), concepts and conventions. Accounting standards are put in place that stipulates disclosure of accounting policies as well as certain items of information in various forms, parts and formats in the annual reports of companies.

However, the generally accepted accounting principles often allow multiple accounting methods that a company can choose from when estimating certain items. This is due to the many types of businesses in the economy. With all of the different sizes and natures of transactions, it is extremely difficult for there to be just one accounting method for all companies to use, hence, multiple accounting methods exist for companies to choose from. For example, in computing depreciation, managers and accountants have several methods from which they may choose. Examples of these are straight-line and reducing-balance methods. Not only can the managers and accountants select any of the multiple depreciation methods when computing depreciation cost, but they can also pick one method for depreciating one asset, such as buildings, and another method for

depreciating another asset, such as equipment. This depreciation example is just one of the many multiple accounting methods that a company can legally employ. Thus, companies will most likely, if not probably, use the accounting method that will give them their most preferred image.

Furthermore, managers and accountants estimate certain figures in accounting, so they must use their best judgment in estimation. This can also be related to assets. The residual value and the life span must be estimated because management must account for depreciation cost as they are using the asset while actual values are known during disposal of the asset. Thus, managers could essentially manipulate the depreciation amount to the figures that they want. Technically, this is not illegal because they are within their rights to estimate the numbers. Given the various accounting options and techniques, this type of creative accounting will always exist.

2.2 Theoretical Perspective On Creative Accounting

2.2.1 Meaning of Creative Accounting

Creative accounting has been defined and described in several ways by different authors using different words with some of these definitions showing the bias of the author. I will like to adopt neutral definitions such as the definition by Naser (1993). According to him, Creative accounting is the transformation of financial accounting figures from what they actually are to what preparers desired by taking advantage of the existing rules and/or ignoring some or all of them.

BusinessDictionary.com has this description of Creative accounting:

"the use of unorthodox techniques which, while following provisions of GAAP, paint a desired (negative or positive, as the case may be) picture of a firm's finances. For example, selling an asset (whose market value is high but book value is low) to create non-operating profit that offsets operating loss. Unlike cooking the books, creative accounting is generally legal. Euphemistically also called financial engineering or earnings management".

From definitions above one can conclude that the idea behind creative accounting practices is to emphasize the positive aspects of the company's financial situation while downplaying negative factors.

2.2.3 Review of Literature on Ethical Theories

While creative accounting may not be illegal, it poses or raises a number of ethical challenges to the profession and the firm. For instance, creative accounting puts one group or two stakeholders to advantageous position at the expense of others. To be able to establish whether creative accounting is ethical or not, we may need to borrow from philosophy by examining what ethics is and when is an action ethical or not based on ethical theories. In a situation of ethical dilemma, which is prevalent in financial reporting, what should the accountant do not to go against the ethics of his profession?

Ethics, also called moral philosophy, involves systematizing, defending and recommending concepts of right and wrong behaviour. Ethics generally attempts to state or determine what is good, both for the individual and for the society as a whole. Ethics explores how human beings should act in all earthly situations to ensure that in all that a person does, there are good reasons to take other people's interests into consideration. A guiding principle appears to be that one should be fair and seek to uphold the common good of the community to which one belongs, in the spirit of duty of care to one's neighbours.

Accounting ethics is a subspecies or sub-set of business ethics which is part of applied ethics. Applied ethics is the normative practice of ethics that deals with analysis of specific, controversial moral issues in particular disciplines, professions, organisations or practical field. According to Almond, applied ethics is "the philosophical examination, from a moral standpoint, of particular issues in private and public life that are matters of moral judgment". Applied ethics applies normative ethics to specific controversial issues, investigates the principles upon which certain actions are said to be good or bad, right or wrong. The basic normative ethical theories are reviewed below.

(a) Theory of Conduct

This is the study of right and wrong, of obligation and permissions, of duty, of what is above and beyond the call of duty, and of what is so wrong as to be evil. Theory of conduct proposes standards of morality, or moral codes or rules. For example, the following would be the sort of rules that theory of conduct would discuss: "Do unto others as you would have them do unto you"; "Stealing is wrong."

(b) Teleological theories determine whether an act is wrong or right by looking at the probable outcomes or consequences of the decision (the ends). It judges the rightness or wrongness of an action based on its

consequences. Actions are therefore not good in themselves; their moral values are totally based on the effects that follow upon them. Actions have no intrinsic value but merely serve as means to attain that which has value. In considering the consequences of an action, the good effect should be weighed against the bad effects on all the people affected by it. If the good effects outweigh the bad effects, then it tends to be a good action, but if the bad outweighs the good, then it tends to be a bad action, hence not morally right.

(c) Ethical Egoism

Ethical egoism expresses 'the view that human conduct should be based exclusively on self-interest.' Ethical egoists believe that morality requires nothing more of us other than we maximise our own good. Therefore, an action is right if it maximises one's own personal good. Some of the propositions are: "each and every man ought to look out for himself alone... everyone ought to concern himself with his own welfare alone." "One's sole duty is to promote his own interests" and "everyone ought exclusively to pursue his own interest."

(d) Utilitarianism

Utilitarianism, otherwise known as the 'greatest happiness principle', is an ethical theory that: an action is right if it produces, or tends to produce, the greatest amount of good for the greatest number of people affected by the action; otherwise the action is wrong. According to Bentham, actions were right if they tended to produce the greatest happiness for the greatest number of people.

(e) The deontological theorists consider the process of the decision (the means) to determine whether an act is wrong or right. To them, what makes an action right is not the sum of its consequences, but the fact that it conforms to the moral law, obligation or duty. On this basis, an action or decision is justified for the fact that it is good.

(f) Ethics of Duty (Kantianism)

According to Kant, whether an action is wrong or right has nothing to do with the situation or consequences of the action, rather, it depends on certain eternal, abstract and unchangeable principles that humans should apply to all situations. To be ethical, therefore, one must consciously act according to rules previously calculated by 'reason' to be right or just, and the incentive for observing those rules must be respected for duty alone. He developed a theoretical framework through which guiding principles to what ought to be our commitment to duty could be derived. This he called the 'categorical

imperative'. These principles should be applied to every moral issue regardless of who is involved, who profits and who is harmed by the principles once applied in specific situations (for detailed information on categorical imperative see Financial reporting and Ethics Manual by ICAN).

(g) Virtue Ethics (Aristotleism)

Instead of evaluating every single action based on its outcomes, or its underlying principles, this approach looks at the character of the decision maker. Basically the theory holds that good actions come from good people. The primary objective is not the abstract knowledge of the good but to become a good person or develop a moral character. Virtue ethic contends that morally correct actions are those undertaken by actors with virtuous characters. Therefore, the formation of a virtuous character is the first step towards morally correct behaviour and this is acquired through 'good upbringing and nurtured over time from childhood. Thus, being ethical or doing what is morally right is not about being obedience to rules or a common social habit, but the inculcation of virtues, that is, the traits of characters that promote human conviviality.

2.2.4 Ethical Dilemma

Dilemma has been described as "a position or situation giving a choice of two courses of action, usually both equally unpleasant." Both can also be equally pleasant. In ethics, the word dilemma may be defined as "a situation in which all the available courses of action appear to include morally undesirable as well as morally desirable aspects." A situation of dilemma carries the risk of being wrong, on one hand, and the glamour of being right, on the other hand, with the potentiality of making it or paying for it.

Confusion could set in; with the decision maker not knowing what to do, when duties and rights conflict with each other. Accounting ethics have to do with the business and professional way, practically, rather than the theoretical or philosophical outlook. Therefore, in situation of ethical dilemma, the accountant should examine his personal values vis-a-vis those embodied in his professional activities. This leads us to consider the code of ethics of a professional accountant.

2.2.5 Professional Ethics in Accounting

The professional accountant is obliged to observe a number of ethical rules of professionalism in the conduct of his assignment. The International Federation of Accountants (IFAC) through its International Ethics Standards Board issued the revised July 2009 Code of Ethics to regulate the activities of professional accountants among member bodies, including the Institute of Chartered Accountants of Nigeria (ICAN). These ethical standards are designed as 'pillars of guidance,' to safeguard the integrity of the professional body and obviate untold humiliation in the eyes of the world. The general application of the Code touches on many and diverse issues which include the following: Integrity, Objectivity, Professional Competence and Due Care, Confidentiality as well as Independence and they are discussed below.

Integrity

According to Section 110.1 of the Code, a professional accountant owes the obligation to be honest and straight forward in all business and professional relationships. The concept of "integrity" carries along fair dealing and truthfulness. Section 110.2 of the Code says that a professional accountant should not deliberately be associated with returns, reports, etc. which he believes contains a statement or statements furnished recklessly, which are false, misleading or obscure information required to be made available.

Objectivity

Professional accountants are under obligation not to negotiate their business or professional judgment on account of bias, undue influence of other people or indeed conflict of interest. Situations which may impair objectivity are not clear – cut. It is up to a professional accountant to detect situations of impairment. He should not render a professional service where a situation or relationship unduly influences or biases the accountant's professional judgment in regard to that service. This further requires the accountant to be Independent.

Independence

Independence connotes being in a position to take an unbiased viewpoint in the performance of professional assignments. Accountants must not only maintain an independent attitude in fulfilling their responsibilities, but the users of financial reports must have confidence in that independence.

Professional Competence and Due Care

Professional accountants are obliged to demonstrate and maintain professional skills and knowledge so as to deliver competent services. They should act diligently, as required by applicable professional and technical standards. Competent and diligent professional service calls for the use of sound and analytical mind in applying professional skills and knowledge in the course of executing such services. Attaining and maintaining professional competence is a continuing endeavour which should lead to the understanding of developments in business, technical and professional areas. Diligence includes the obligation to act within the requirements of an assigned work, taking into account timeliness, carefulness and thoroughness in execution. A professional accountant should ensure that those who are under his authority and working for him in a professional situation are in possession of appropriate training and are well supervised. Where necessary, a professional accountant is obliged to prepare the minds of clients, employers and other users of the professional accountant's services on the possible limitations which are inherent in the services rendered.

Confidentiality

The concept of confidentiality, according to IFAC (2009), restrains professional accountants from:

- (a) Disclosing information obtained in the course of business and professional interactions, outside the company or employment house, without proper and clear – cut authority, or without prejudice to a professional or legal duty to so disclose; and
- (b) Using information obtained as a result of business and professional relationships, for their personal benefits or the advantage of third parties.

A professional accountant has the responsibility of ensuring that his staff and individuals from whom counsel and assistance are obtained respect the professional accountant's duty of confidentiality. The need to uphold the principle of confidentiality continues after the end of the business or professional relationships between a client or employer and the professional accountant.

Professional Behaviour

The concept of "professional behaviour" is in Section 150.1 of the Code of Ethics (2009). The principle imposes an obligation on professional accountants to adhere to all relevant laws, rules and

regulations. It obliges a professional accountant to avoid any action which he knows or is supposed to know may impugn the integrity of the profession. What may discredit the profession includes all actions which a reasonable and informed third party, having regard to all the facts and circumstances available to the professional accountant in that situation, should know would adversely put the reputation of the profession in jeopardy.

At national levels, the various professional bodies use the instruments of regulation, ethical rules and technical standards as benchmark of performance measurement for professional accountants. They are readily available for the purpose of performing oversight functions of monitoring and punishing errant professional accountants. The Institute of Chartered Accountants of Nigeria, has a monitoring organ called, the Professional Practice Monitoring Committee, which carries out this oversight functions on its behalf.

2.3 Empirical Analysis and Practical Issues on Creative Accounting

2.3.1 Why Entities Engaged In Creative Accounting

Managers are not inherently unethical neither do they attempt at every opportunity to exploit the investors and creditors who provide the company's capital. However, it is well known that managers choose those accounting methods and estimates that report the result of their actions in ways that protect and further their own interest. This is because they are fully aware that outsiders use the financial statements to evaluate management performance; decide whether to buy, sell or hold the company's shares and that management's future levels of wealth are often directly or indirectly tied to the financial accounting numbers. Hence, the motivation to manage the numbers (Akintoye 2006). Therefore, motivation to engage in creative accounting may arise out of personal incentives, bonus from shares, tax management, job security and management buyouts. These motivating factors result into management involvement in earnings management of different types; income smoothing or income-boosting as enumerated by Amat, Blake and Dowds (1999).

Companies generally prefer to report a steady trend of growth in profit rather than to show volatile profits with a series of dramatic rises and falls. This is achieved by making high provisions for liabilities and

depreciation against asset values in good years so that these provisions can be reduced, thereby improving reported profits in bad years. A variant of income smoothing is to tie profit to forecasts. Fox (1997) reports on how accounting policies at Microsoft are designed, within the normal accounting rules, to match reported earnings to profit forecasts. When Microsoft sells software, a large part of the profit is deferred to future years to cover potential upgrade and customer support costs. This conservative accounting policy means that future earnings are easy to predict. It has also been established in the literature that firms engaged in earnings management to prevent violations of debt covenants (Gaa, 2007).

Company directors may keep an income-boosting accounting policy change in hand to distract attention from unwelcome news. Collingwood (1991) reports on how a change in accounting method boosted K-Mart's quarterly profit figure by some \$160 million, distracting attention from the company slipping back from being the largest retailer in the USA to the number two slot.

One other strong reason why reporting entities engaged in creative accounting is to maintain or boost the share price both by reducing the apparent levels of borrowing, so making the company appear subject to less risk, and by creating the appearance of a good profit trend. This helps the company to raise capital from new share issues, offer their own shares in takeover bids, and resist takeover by other companies. If the directors engage in 'insider dealing' in their company's shares they can use creative accounting to delay the release of information for the market, thereby enhancing their opportunity to benefit from inside knowledge.

2.3.2 Avenues Employed for Creative Accounting

The potential for creative accounting is found in six principal areas: regulatory flexibility, a dearth of regulation, a scope for managerial judgement in respect of assumptions about the future, the timing of some transactions, the use of artificial transactions and finally reclassification and presentation of financial numbers.

The generally accepted accounting principles (GAAP) are set to give managers and accountants various accounting methods from which they can select. When applying certain methods, the companies are going to choose the ones that make their financial statements

better. This is the nature of business—to make the company succeed as much as possible; with creative accounting assisting in this endeavour. Business entities may, quite validly, change their accounting policies. Even in a highly regulated accounting environment such as the USA, a great deal of flexibility is available (Largay, 2002; Mulford and Comiskey, 2002).

Some areas are simply not fully regulated. For example, there are (as yet) very few mandatory requirements in respect of accounting for stock options. In the majority of countries, Spain for example, accounting regulation in some areas like the recognition and measurement of pension liabilities and certain aspects of accounting for financial instruments is limited.

Management has considerable scope for estimation in discretionary areas. Another area where estimation takes place, apart from depreciation discussed earlier, is when making provision for bad debts. McNichols and Wilson (1988) examine the discretionary and nondiscretionary elements of the bad debts provision.

Genuine transactions can also be timed so as to give the desired impression in the accounts. For instance, suppose a business has an investment at historic cost which can easily be sold for a higher sales price, being the current value. The managers of the business are free to choose in which year they will sell the investment and so increase the profit in the accounts.

Reporting entities could enter into artificial transactions to manipulate balance sheet amounts and move profits between accounting periods. This is achieved by entering into two or more related transactions with an obliging third party, normally a bank. For example, supposing an arrangement is made to sell an asset to a bank then lease that asset back for the rest of its useful life. The sale price under such a 'sale and leaseback' can be pitched above or below the current value of the asset, because the difference can be compensated for by increased or reduced rentals.

Reclassification and presentation of financial numbers are relatively under-explored in the literature. However, the study by Gramlich et al. (2001) suggests that firms may engage in balance sheet manipulation to reclassify liabilities in order to smooth reported liquidity and leverage ratios. A special type of creative accounting relates to the presentation of financial numbers, based on cognitive reference points. As explained by Niskanen and Keloharju (2000): 'the idea behind this

behaviour is that humans may perceive a profit of, say, 301 million as abnormally larger than a profit of 298 million'. Their study and others (e.g. van Caneghem, 2002) have indicated that some minor massaging of figures does take place in order to reach significant reference points. However, this could fall into an unethical area if the true values are grossly misrepresented. Other strategies employed by the managers include;

- Taking a 'big bath', where a company making a bad loss seeks to maximize the reported loss in that year so that future years will appear better.
- Creating hidden reserves during periods of extremely good performance.
- Employing off balance sheet financing

3.0 METHODOLOGY

The Disclosure Index, adopted from Standard & Poor's Transparency & Disclosure Survey 2001 as used by Hancock (2004) and Medeiros and Quinteiro (2006), was employed to analyse the content of annual report of the banks and assess their level of compliance with disclosure regulation. The index is a computation based on number of items disclosed as compared to number of items expected to be disclosed. The questions admit a binary answer: 1, when the item is disclosed and 0, otherwise. The detail of how the disclosure item list was developed and the index computed is in the next section.

The sample for this study consists of eight banks listed on the Nigerian Stock Exchange (NSE) between 2000 and 2011. Some of the eleven banks listed in the market as at year end of 2013 were excluded from the study because they were listed during the study period. There was a reclassification of the sectors on NSE in 2012 as well as the adoption of the IFRS by listed firms; therefore 2012 and 2013 were left out of the analysis.

3.1 Development of Disclosure Item List and Computation of Disclosure Index

A detailed analysis of statutory requirements on disclosure by relevant laws for insured banks in Nigeria as well as disclosure items list used by other researchers (Hancock, 2004; Karim and Ahmed, 2005 and Medeiros and Quinteiro, 2006) was undertaken. This enables the development of disclosure item list used to analyse the content of annual reports of the banks and determine their level of compliance with disclosure regulation. Financial and non-financial information items

as well as voluntary and mandatory disclosures were included in the list which has 60 items out of which 50 are mandatory while 10 are voluntary. This figure is believed to be on the average sufficient, 82 items have been identified by one of the studies to be too many, while a list as small as 17 items may not contain relevant information items (Hooks, Coy and Davey 2000). The disclosure item list is presented in Table 1 below.

A company is awarded a score of 1 if an item is disclosed and 0 if otherwise. The total number of items disclosed by a company is then divided by the total number of items applicable to the company and the result is used as the disclosure index (DI) for the firm. The initial construct of disclosure index made the overall score attributed to firms to vary from 0 to 10, this was modified in this study to percentage score to highlight clearly the variations. Therefore, overall score (DI) attributed to firms vary from 0 to 100, computed as follows:

$$\text{Score (DI)} = \frac{\text{No of items disclosed}}{\text{Total No of items to be disclosed}} \times 100$$

For instance, mandatory disclosure index (MDI) for a firm which discloses 37 items out of 50 mandatory items is 74%.

Table 1. Disclosure Item List

S/N	Required by Law	S/N	
1	The Period Covered by the account	32	Interest Expenses And Similar Charges
2	Accounting Policies	33	Dividend Proposed
3	Balance Sheet	34	Dividend Paid

4	Income Statement	35	Dividend Liability
5	Cash Flow Statement	36	Total of fixed assets
6	Value Added Statement	37	Details of assets acquired through hire purchase
7	Auditors Report	38	Details of assets on Lease
8	Directors Report	39	Total & Details of long-term debts (including tenure)
9	Audit Committees Report	40	Total current assets
10	Five Years Financial Summary	41	Total current liabilities
11	Chairman's Report	42	Directors emoluments
12	Notes to the Accounts	43	Directors Direct & Indirect Holdings in the Issued Shares
13	Company's Name	44	Substantial Shareholdings Representing 5% Or More Of The Issued Shares
14	Legal Status	45	Capital Expenditure
15	Auditor's Name	46	Name of its subsidiaries or associated companies (if applicable)
16	Auditor's Fee	47	Country of operation of subsidiaries or associated companies (if applicable)
17	Other Payment To Auditor	48	Nature and quantum of interest of the company in each subsidiary or associated company (if applicable)
18	Ownership Structure	49	Arrangement for the waiver of directors' emoluments (if any)
19	Related Party Transactions	50	Any person apart from the directors holding more than 5% of the shares of the company (if any).
20	Method Of Depreciation		Voluntary disclosure

21	Method Of Asset Valuation	51	Accounting Standard Used For Its Report
22	Turnover	52	Detail of Kind of Business
23	Profit Before Tax	53	Detail of Its Product
24	Tax Payable	54	Overview of Trends in the Industry
25	Tax Paid	55	Forecast of any type
26	Tax Liability	56	Market Price of Its Share
27	Profit after Tax	57	Earnings per Share
28	Assets Employed	58	Dividend per Share
29	Issued And Paid Up Capital	59	Net Asset per Share
30	Reserves	60	Gearing Ratio
	Sales And Profit Contribution		
31	Per Activity		

Source: Author's Compilation

4.0 DISCUSSION OF FINDINGS

The scores for mandatory and voluntary disclosures and the disclosure indices of the banks are presented in Table 2. Each bank was scored in relation to the proportion of mandatory and voluntary items contained in its annual report. From this table, the banks scored high on mandatory disclosure. The minimum and highest scores are 76% and 92% respectively; with mean and median distribution of 84%. This result infers high level of compliance with accounting information disclosure regulation in Nigeria.

The voluntary disclosure scores and indices for many of the firms are very low, with a mean score of 39% while the maximum and minimum scores are 60% and 20% respectively. This finding suggests reluctance on the part of corporate firms to disclose information more than the level prescribed by law. The compiled voluntary disclosure items are those identified in the literature as important input for informed share investment decisions.

These include: net asset per share, price earnings ratio, current market value of their shares, return on equity and gearing ratio (GR). For instance, the gearing ratio, which none of the firms disclosed, informs the investors about the financial risk exposure of the firm which should be of interest to and should not be ignored by an informed investor.

Table 2. Disclosure Scores and Disclosure Indices

BANK	YEAR	MSCORE	MDI	VSCORE	VDI	BANK	YEAR	MSCORE	MDI	VSCORE	VDI
Access Bank	2000	40	80	4	40	sterling Bank	2000	41	80	3	30
Access Bank	2001	40	80	4	40	sterling Bank	2001	41	80	3	30
Access Bank	2002	40	80	4	40	sterling Bank	2002	41	80	3	30
Access Bank	2003	40	80	4	40	sterling Bank	2003	41	80	3	30
Access Bank	2004	42	84	3	30	sterling Bank	2004	41	84	3	30
Access Bank	2005	42	84	3	30	sterling Bank	2005	41	84	3	30
Access Bank	2006	42	84	3	30	sterling Bank	2006	41	84	3	30
Access Bank	2007	42	84	3	30	sterling Bank	2007	41	84	3	30
Access Bank	2008	44	88	3	30	sterling Bank	2008	41	88	3	30
Access Bank	2009	44	88	3	30	sterling Bank	2009	41	88	3	30

Access Bank	2010	44	88	3	30	sterling Bank	2010	41
Access Bank	2011	44	88	3	30	sterling Bank	2011	41
AVERAGE		42	84	3	33	AVERAGE		41
AfribankPlc	2000	38	76	5	50	UBAPlc	2000	44
AfribankPlc	2001	38	76	5	50	UBAPlc	2001	44
AfribankPlc	2002	38	76	5	50	UBAPlc	2002	44
AfribankPlc	2003	38	76	5	50	UBAPlc	2003	44
AfribankPlc	2004	43	86	5	50	UBAPlc	2004	44
AfribankPlc	2005	43	86	5	50	UBAPlc	2005	44
AfribankPlc	2006	43	86	5	50	UBAPlc	2006	44
AfribankPlc	2007	43	86	5	50	UBAPlc	2007	44
AfribankPlc	2008	43	86	5	50	UBAPlc	2008	44
AfribankPlc	2009	43	86	5	50	UBAPlc	2009	44
AfribankPlc	2010					UBAPlc	2010	44
AfribankPlc	2011					UBAPlc	2011	44
AVERAGE		41	82	5	50	AVERAGE		44
First Bank	2000	42	84	5	50	Union Bank	2000	40
First Bank	2001	42	84	5	50	Union Bank	2001	40
First Bank	2002	42	84	5	50	Union Bank	2002	40
First Bank	2003	42	84	5	50	Union Bank	2003	40

First Bank	2004	42	84	5	50	Union Bank	2004	40
First Bank	2005	42	84	5	50	Union Bank	2005	40
First Bank	2006	42	84	5	50	Union Bank	2006	40
First Bank	2007	45	90	5	50	Union Bank	2007	40
First Bank	2008	45	90	5	50	Union Bank	2008	40
First Bank	2009	45	90	5	50	Union Bank	2009	40
First Bank	2010	45	90	5	50	Union Bank	2010	40
First Bank	2011	45	90	5	50	Union Bank	2011	40
AVERAGE		43	87	5	50	AVERAGE		40
GTBPlc	2000	41	82	4	40	Wema Bank	2000	40
GTBPlc	2001	40	80	4	40	Wema Bank	2001	40
GTBPlc	2002	40	80	4	40	Wema Bank	2002	41
GTBPlc	2003	40	80	4	40	Wema Bank	2003	41
GTBPlc	2004	44	88	5	50	Wema Bank	2004	41
GTBPlc	2005	44	88	5	50	Wema Bank	2005	46

GTBPlc	2006	44	88	4	40	Wema Bank	2006	46
GTBPlc	2007	44	88	4	40	Wema Bank	2007	46
GTBPlc	2008	44	88	4	40	Wema Bank	2008	46
GTBPlc	2009	44	88	4	40	Wema Bank	2009	46
GTBPlc	2010	44	88	4	40	Wema Bank	2010	46
GTBPlc	2011	44	88	4	40	Wema Bank	2011	46
AVERAGE		43	86	4	42	AVERAGE		44

MSCORE= Mandatory Disclosure Score VSCORE= Voluntary Disclosure Score

Source: Author's Computation

The study discovered that a few of the banks changed the format with which they presented their account between year 2005 and 2009. Although, the format of account changed to was one of the formats attached to CAMA as appendix, it seems as if the change was made to conceal the fact that the banks were having negative net assets. This is drawing attention to the fact that firms could hide under the provisions of the law to window-dress their account. Also, over the 12 years covered by this study, the disclosure scores for most of the banks remain unchanged. The banks were in the habit of "cutting" the old figures and just "pasting" the new figures. Many of them submitted their annual reports later than required by the law and therefore, during the study period, many of the reports that should be used in the market were not available.

5.0 CONCLUSIONS AND RECOMMENDATIONS

Creative accounting offers a formidable ethical challenge to the accounting profession and there is the need to be aware of the scope for both abuse of accounting policy choice and manipulation of

transactions. Creative accounting raises a big question of reliability of accounting information. All stakeholders should be cautious of the fact that the techniques change over time. It has been established in the literature that many of the changes in standards are to erase possible manipulations while other well intentioned changes in standards open up new opportunities for creative accounting (a good example of this is the use of fair value).

However, a well-designed framework of accounting regulation can curb creative accounting; there should be financial reporting standards in areas where there is dearth of regulation. Rules should be properly drafted and regulatory authority should ensure that adequate enforcement mechanisms are put in place.

Investors should not take corporate disclosures at their face value but engage experts as much as possible before embarking on investment decision. Some accounting figures could be removed from the main statement to be evident elsewhere, most often in the notes to the accounts. Experts can still unravel a lot of hidden items.

Management and firm's accountant should be cautious of using creative accounting; it should be used if it is within the ramifications of the law and benefit the company in the long run.

References

- Akenbor, C. O. and Ibanichuka, E. A. L (2012). Creative Accounting Practices in Nigerian Banks, *African research review An International Multidisciplinary Journal*, Ethiopia Vol. 6 (3), Serial No. 26, DOI: <http://dx.doi.org/10.4314/afrrrev.v6i3.2>
- Akintoye, I. R 2006. *Investment decisions: concepts, analysis and management*. Unique Publication.
- Amat, O; Blake, J. and Dowds, J. (1999). –The Ethics of Creative Accounting; *Journal of Economic Literature*.
- Collingwood, H (1991). Why K-Mart's Goodnews isn't; *Business Week*; March; 40
- Fox, J. (1997) 'Learn to play the Earnings Game', *Fortune*, 31 July.
- Gaa, J. 2007. *The Ethics of Earnings Management: The Case of Income Smoothing*, University of Alberta
<http://www.victoria.ac.nz/sacl/research/researchseminarseries/jg310507>
- Glautier, MWE and Underdown, B 2001. *Accounting Theory and Practice*, 7th edition, Prentice Hall, London.
- Gramlich, J.D, McAnally, M. L. and Thomas (2001). "Balance sheet management: the case of short-term obligation reclassified as long-term debt", *Journal of Accounting Research*, Vol. 39.2; 283-295.
- Hancock, D 2004. *Disclosure, volatility and transparency*. Board of Governors of the Federal Reserve System

Hooks, J; Coy D, and Davey H. 2000. Accountability through annual reporting
by NewZealand electricity retail and distributionCompanies

International Federation of Accountants (IFAC): "Code of Ethics
for ProfessionalAccountants": International Standards Board
for Accountants – July, 2009.

Karim, A K M W. and Ahmed, J. U. 2005.
Determinants of IAS disclosure compliance
in emerging economies: evidence from exchange
listed companies in Bangladesh. *Working Paper Series*, No. 21

Largay, J, 2002: "Lessons from Enron", *Accounting Horizon*, Vol.
16.2:154-160.

McNichols, M and Wilson, G.P 1988: "Evidence of creative accounting
from
the provision for bad debts" *Journal Of Accounting Research* Vol
26,
Supplement: 1-33

Medeiros,O. R.and Quinteiro,L. G.2006. Disclosure of accounting
information and stock return volatility in Brazil

Morgan, G. 2009."Riding the Waves of Change"York University
Bookstore Press, Toronto.

Mulford, C. W. and Comiskey, E. E 2002. "The financial numbers
game:
detecting creative accounting practices" NewYork: Wiley.

Naser, K. (1993). *Creative Financial Accounting: Its Nature and Use*,
Hemel Hempstead: Prentice Hall.

Needles, B. E and Powers M Jr. 1998. *Financial accounting (Sixth
Edition)*, Houghton Mifflin Company

Niskanen, J and Keloharju, M. 2000: "Earnings cosmetics in a tax-driven accounting environment" the European accounting review, Vol.9.3:443-452.

VanCaneghem, T 2002. "Creative accounting induced by cognitive reference points" British Accounting Review 34:167-178

Simon, D.T. and M. Taylor. 2002. The Market for Audit Services in Nigeria.
Research in Accounting in Emerging Economies. London. Elsevier

Standard & Poor, Standard & Poor's Company Transparency & Disclosure
Survey. 2001.<http://www2.standardandpoors.com/>,

FINANCE

DETERMINANTS OF DIVIDEND POLICY OF CORPORATE FIRMS IN NIGERIA

By

Adelegan, O.J

Adeyemo, K.A,

Adejuwon J.A,

Taiwo, A.O

Department of Management and Accounting,
Lead City University, Ibadan, Oyo State, Nigeria.

Email: olatundunja@yahoo.com;
waltol12@yahoo.com; adejuwonwj@yahoo.com,
remadeyemo2003@yahoo.com

+2347063872489

Abstract

The study sets out to identify the determinants of dividend policy of firms in Nigeria from 2005 to 2013. The study analysed data of manufacturing firms listed on the Nigerian stock exchange for 221 firm year study using the Lintner model as the theoretical framework. Data on the dividend, profit after tax, total distributable earnings, leverage and market to book value were obtained from annual reports of firms. Using ordinary least square regression, the pooled regression result shows that total distributable earnings determines dividend payout of corporate firms in general in Nigeria. Results of sectoral analysis show that dividend policy of manufacturing firms depend on profit after tax and earnings. The result also shows that the manufacturing firms ability to pay dividend depends more on profit after tax. The coefficients of leverage and market to book value are not statistically significant. However, there is enough evidence to conclude that profit after tax and total distributable earnings are key determinants of firm dividend payment in Nigeria. There is need for firms to improve on their performance and increase their profitability level in order to have enough that will be transfer to the revenue reserves for future dividend payment, especially when there is recession in the economy as dividend payment is a key factor in growing investors' confidence as well as enhancing the market value of firms.

Keywords: Dividend, profit, total distributable earnings, leverage, market to book value.

1. Introduction

When a firm pays cash dividend or omits such a payment the firm is making an extremely visible and qualitative change in corporate policy. The decision may have a short and long term effect on the performance of the price and volume of the company's shares (Naranjo et al, 1998; Amihud and Murgia, 1997; Michaely et al, 1995; Dhillon and Johnson, 1994). An optimal dividend policy should ensure that the wealth of the shareholders is maximized. This will in turn help in mobilizing resources to productive investment opportunities on the stock market and ultimately result in economic growth (Adelegan, 2007). For Nigerian Corporate firms to continue to harness fund from local and foreign investors to viable investment opportunities that will bring about economic growth, it is expected to maintain an optimal dividend policy. This has made it imperative for researches to be done in this area to identify the determinants of dividend policy of corporate firms in Nigeria.

The study of dividend policy started to receive attention among academic scholars in Nigeria in 1974 when Uzoaga and Alozienwa attempted to highlight the pattern of dividend policy pursued by Nigerian firms particularly since and during the period of indigenization and participation programme defined in the decree. They concluded that fear and resentment seem to have taken over from the classical forces. Subsequent studies by Inanga (1978) and Soyode (1975) questioned certain conclusions made by Uzoaga and Alozieuwa, 1974 because they are inadequate or a mistaken evaluation. Other studies on dividend policy in Nigeria include Oyejide (1976), Odife (1977), Izedonmi and Eriki [1996], Adelegan and Inanga, 2001, Adelegan (2000a and b, 2003a and b, 2006a and b, 2009), Adesola and Okwong (2009), Nwodibie, (2013), Adediran and Alade (2013). They found out that there is a significant positive relationship between dividend policies of organizations and profitability, investments and earnings per share and share prices. However, there has been some policy changes that have implications for corporate firms and economic growth. Our study improve on previous studies by using more recent data in the light of new policy pronouncements to study the dividend behavior of corporate manufacturing firms listed on the Nigerian stock market. It is therefore our overall aim in this study to identify the determinants

of dividend policy of manufacturing firms in Nigeria.

2. Literature Review

The earliest research on determinants of dividend policy was conducted by Lintner (1956) who conducted his study on American companies in the middle 1950s. The study concluded that decision is based upon the current profitability and in part on the dividends of the previous year. Since then debate on dividend payments have been on-going but the results are mixed and at times conflicting. Studies have been carried out in both emerging and developed economies. In Nigeria, earlier studies include Uzoaga and Alezieuwa (1974), Soyode (1975), Inanga (1975) Oyejide (1976), Odife (1977), Izedonmi and Eriki [1996], Adelegan and Inanga, 2001, Adelegan (2000a and b, 2002a and b, 2003a and b, 2006a and b, 2009), Adesola and Okwong (2009), Nwodibie, (2013), Adediran and Alade (2013).

Brealey and Myers (2005) listed top ten problems that are unresolved in advance corporate finance and one of them is dividend policy. In empirical literature, one of the important finance issues that are investigated intensely is to find the factors affecting firm's dividend policy. Previous studies related to Pakistan show that dividend announcement affects the share price and market efficiency, Akbar & Baig (2010). Ahmed & Attiya (2009) find that dividend policy is affected by earnings per share (EPS) and by previous dividend per share. Al-Twajjry (2007) confirmed that current dividends are affected by the past and future earnings. Also that dividends were associated with net earnings but less strongly.

An alternative view of dividends as proposed by DeAngelo et al (2006), is that optimal payout policy is driven by the need to distribute the firm's free cash flow. They predicts that in their earlier years, firms pay few dividends because their investment opportunities exceed their internally generated capital. In later years, internal funds exceed investment opportunities, so firms optimally pay out the excess funds

in order to mitigate the possibility that the free cash flows will be wasted. Thus DeAngelo, et al (2006) find that the propensity to pay dividends is positively related to the ratio of retained earnings to total equity, their proxy for the firm's life-cycle stage. They further noted that firms with low earned/contributed equity would appear to be the ideal candidates for dividend signaling because these firms are less mature and it is, therefore more difficult to gauge their future prospects. Yet these are the firms that do not pay dividends.

A study in the context of Ghana was conducted by Amidu and Abor (2006). The result indicate that there is positive association between profitability and dividend policy and liquidity and dividend policy. They found a positive relationship between the payment of dividend, cash flows, profitability and corporate tax. They also found out that there is a negative relationship between payout ratio and risk.

Nnadi and Akpomi (2008) and Asamoah (2010) focused on various implications of dividend policy in developing economies, particularly Africa and showed a significant effect of profit on dividend and a positive relationship between tax, profit and dividend. Ali (2007) examined listed firms in the Tunisian stock exchange and found out that dividend policy of corporations is significantly different from the widely accepted policy of corporations operating in developed markets. Generally, the dividend policy of firms in developing varies in some respects with those of developed economies (Taneem and Yuce, 2011).

Aivazian et al (2007) tried to establish a link between the firm dividend policy and stock market liquidity of NYSE and AMEX firms for the period 1963 to 2003. In the cross section analysis, they found that the owners of less (more) liquid common stock are more (less) likely to receive cash dividends.

Gill et al (2010) analysed the American service and manufacturing firms and found that the dividend payout ratio is a function of profit margin, sales growth, debt-to-equity ratio and tax. For the services

industry, the dividend payout ratio is a function of profit margin, sales growth and debt-to-equity ratio.

Malkawi (2007) studied the determinants of corporate dividend policy in Jordan for a period between 1989 and 2000. Size, age and profitability of the firms have been found to be the determinant factors of corporate dividend policy in Jordan. The findings provide strong support for the Agency costs hypothesis and are broadly consistent with the pecking order hypothesis.

Kuwari (2009) studies the determinants of the dividend policy in Gulf Cooperation Council (GCC) countries. The study investigated the determinants of dividend policy for non-financial firms listed on the GCC country stocks exchanges. The study found out that the firms pay dividend with the intention of reducing the agency problem and the listed firms in GCC countries alter their dividend policy frequently and do not adopt a long-run target dividend policy. The study concluded that dividend payments are strongly and directly related to government ownership, firm size and firm profitability but negatively to the leverage ratio.

Ahmed and Javid (2009) find out the determinants of dividend payout policy of non-financial firms listed in the Karachi Stock Exchange during the period of 2001 to 2006. The study supported Linter's policy. They clearly demonstrated that the firms rely on both current earnings per share and past dividend per share to set their dividend payments. The profitability, market liquidity and ownership have positive impacts on the dividend payout whereas market capitalization and size of the firms have negative impact on dividend payout policy which clearly shows that the firms prefer to invest in their assets rather than pay dividends to shareholders.

Li and Lie (2006) have maintained that firms are more likely to raise their dividends if they are large and profitable. Afzal & Mirza (2010)

found positive association of operating cashflows and profitability with dividend policy, whereas negative association was found for ownership, cash flow sensitivity size and leverage.

The empirical evidence regarding the relationship of leverage with dividend payout is mixed. The higher the leverage, of the firm, the lower the dividend payout; this could be because of the debt covenants. The firm's financial leverage is significantly and negatively related to its dividend policy Al-Malkawi (2007), whereas Kania and Bacon (2005) have found a significant positive relationship, bringing out the fact that the firms have higher debt funds to pay off dividends.

The liquidity or cash flows position is another important determinant of dividend payouts. Firms with more liquidity are more likely to pay dividends as compared to firms with a liquidity crunch. A poor liquidity position means a less generous dividends due to shortage of cash (Kanwal and Kapoor 2008; Ahmed and Javid 2009)

Menta (2012) empirically analysed the determinants of dividend policy, evidence from United Arab Emirate (UAE) companies. The study examined a range of determinants of dividend policy: Profitability, Risk, Liquidity, Size and Leverage of the firms. The study concluded that profitability and size are the most important considerations of dividend payout decisions by UAE firms.

Sajid 2012) investigated the impact of different firm specific factors on the dividend policy of companies by selecting a sample of banks listed on the KSE for the period 2006- 2011. The result showed that there is strong linear association between profitability and firm size with dividend policy, but the variable growth rate has weak positive correlation with dividend policy. In contrast, the variable leverage and firm's risk has inverse linear relationship with dividend policy.

Fakhra and Sajid (2013) examined the determinants of dividend policy of firms listed on the Karachi stock exchange and are part of KSE-100 index, using panel data of 100 financial and non financial firms over the period 2007 to 2009. They found that liquidity, leverage, earnings Per Share (EPS), and size are positively related to dividend; whereas growth, and profitability are found to be insignificant determinants of dividend policy. The results reveals that EPS, company profitability and size increase the probability of companies to pay dividend whereas growth opportunities decrease the probability of paying dividends.

Abdelsalam et al (2008) investigated the dividend policy of 50 listed firms in Egypt for the period 2003-2009. Findings from the study show that a significant positive association existed between institutional ownership and firm's efficiency.

Some studies found positive relationship between share prices and dividend (Fama and French, 1998, Adelegan, 2003b and 2009, Adesola and Okwong (2009)). Empirical evidence in support of information content or signaling theory include Pettit, 1972, Adelegan, 2003b, 2009, Dewenter and Warther, 1998).

Some studies found that lower tax rates are associated with higher dividend shares (Elton and Gruber, 1970, Pettit, 1977, Crossland, Dempsey & Moizer, 1991), while Lewellen et al 1978 reached contrary conclusions.

Adelegan (2000) using data from 1984-1997 found support in Nigeria for Lintner's model. Adelegan and Inanga (2001) carried out a contextual analysis of the determinants of Dividend Patterns of Commercial Banks in Nigeria using 20 banks quoted on the Nigeria stock market for 177 firm year study between 1984 and 1999. The study found that banks growth potentials and banks size affect the association between changes in dividend and cash flow of corporate banking firms in Nigeria. Adelegan, 2003b, 2006a and b, 2009 analysed stock market reactions to dividend intitation and omissions, increase, decrease and no change. Findings point to the fact that

dividend policy matters and share prices do react to dividend announcement, initiation and omissions differently.

Nwodibie, (2013) found out that complaints of shareholders are not a determinant of current and future dividend decisions while there existed an inverse relationship between the needs and desires of shareholders and the naira dividend paid by firms in Nigeria. Adediran and Alade (2013) found out that there is a significant positive relationship between dividend policies of organizations and profitability, investments and earnings per share. There is n

3.Theoretical Framework and Methodology

3.1Theoretical Framework

the study adopted the Lintner 1956 partially adjusted model as modified by Brittain, 1964, Charitous and Vafeas 1998 and Adelegan, 2000. According to the model, firms dividend (D_{it}) is related to the firms earnings (E_{it}) and firms try to maintain dividend at previous levels.

$$D_{it} = rP_{it} \dots \dots (1)$$

where: r is the target payout ratio of dividend to profits.

The year-to-year dividend changes are explained by a partial adjustment form:

$$\Delta D_{it} = ait + Cit (D_{it} - D_{it-1}) \dots \dots (2)$$

where $(\Delta D_{it} = D_{it} - D_{it-1})$ which is change in dividend payments, ait is the constant term. Cit is the speed of adjustment factor normally assumed to lie between zero and unity.

From equations 1 and 2, Lintner derived the dividend model:

$$\Delta D_{it} = a_i + c_i [r_i P_{it} - D_{it-1}] \dots (3)$$

equation 3 implies that current dividend is a function of current earnings and immediate past dividend payments.

Other authors have introduced new explanatory variables into the Lintner model. These include liquidity, sales fluctuation, indebtedness and growth.

3.1 Model Specifications and Method of Analysis

The regression equation tested to provide empirical evidence on dividend policy in Nigeria is stated below.

$$D_{it} = a_0i + b_1iPAT_{it} + b_2iD_{it} + b_3iTDE_{it} + b_4iLEV_{it} + b_5iMBV_{it} + U_{it} \dots (4)$$

where TED is total distributable earnings, LEV is a measure of debt equity ratio and indebtedness and MBV is market to book value which is a measure of growth.

Data was analysed using ordinary least square regression to obtain the parameter estimates.

3.2 Data Sources, Nature and Scope

Data used in this study are mainly from secondary sources which include the Nigerian Stock Exchange fact books, annual report of companies. The study used data of 48 Nigerian listed manufacturing firms from 2009 to 2013. Nigerian Stock Exchange is a reliable source of data of quoted companies because the companies are mandatorily required to submit their financial report to the Nigerian Stock Exchange quarterly and bi-annually. Company annual reports are also reliable because they are statutorily required to be audited by recognized Auditing Firms before publication.

Empirical Analysis

4.1 Descriptive Analysis

Table 1 below presents the sample summary statistics for the dividend per share, profits and total distributable earnings for 221 firm year observations.

Table 1 SAMPLE SUMMARY STATISTICS

VARIABLE	MEAN	MIN	MAX	STD DEV
PAT	0.0993	0	3.825	0.341
LEV	0.4549	0	16.245	2.056
MBV	6.093	0	19.106	19.107
DIV	0.797	0	10	1.515
TDE	3.32	4.62	49.6	8.86
DIVL	0.658	0	7	1.326

Source: Authours' computation

The table indicates that on average the rate of dividend per share is about 80 kobo and the profit after tax is about 10 percent, and the market to book value ratio is 6:1. The mean average of the total distributable earnings (tde) is high. This implies that many companies keep part of their earnings in reserve, in order to grow the business into the future. The debt-equity ratio, which is a measure of leverage, is about 46 percent; this shows that some firms borrow to finance their business. This confirms that two major sources of finance are from borrowed funds and company's retained earnings, which is Shareholder fund accumulated over time and the owners' equity.

The standard deviation of dividend per share is 1.51, which is quite low. The standard deviation of market to book value, total distributable

earnings and leverage are higher than the other variables signifying that they are noisier measures.

Table 2 presents the correlation coefficients of the variables for the 221 firm year study of determinants of dividend policy of firms.

Table 2: Correlation Coefficients of Variables

Variables	DIV	PAT	TDE	LEV	MBV
DIV	1				
PAT	-0.0384	1			
TDE	0.02641	0.04575	1		
LEV	-0.0189	0.062	-0.0247	1	
MBV	-0.0457	-0.0091	-0.0302	0.0025	1

Source: Authours' Computation using Stata.

The correlation between dividend per share and total distributable earnings is positive, while the correlation between the Lagged dividend and PAT is negative. The correlation of the variables are generally low. However, these correlations coefficient primarily have descriptive values and conclusions about determinant of dividend behavior of firms is dependent on the multivariate tests.

4.2 Regression Results

The empirical results of the determinants of dividend behaviour of corporate manufacturing firms are presented in Table 3.

Table 3: Regression results of determinants of dividend policy of manufacturing firms

VARIABLES	MODEL 1	MODEL 2
Cons	0.41569	0.21918

	(1.76)*	-0.18
DIV	0.11036	0.90395
	(-0.55)	-0.65
PAT	0.12206	49.8027
	(-0.37)	(2.68)**
TDE	1.28	7.99
	(6.26)***	(2.90)**
MBV		0.08039
		(0.77)
LEV		-
		0.31993
		(-0.23)
Adj R	45.66%	55.54%

Model 1 presents the parameter estimates of the regression of dividend on past year dividend, profit after tax and total distributable earnings. The coefficient of total distributable earnings is positive and statistically significant. This implies that dividend behavior of firms is determined by the profit accumulated overtime. This result affirms the importance of earnings in the determination of dividend payout. The coefficient of the constant have positive statistically significant relationship with dividend per share, this implies that there are other factors that determine the dividend payout of a firm. The Adjusted R² is about 46%,

Model 2 presents the parameter estimates of the regression of dividend on past year dividend, profit after tax, total distributable earnings, leverage and market to book. . The Adjusted R² is about 56% . The coefficients of profit after tax and total distributable earnings are statistically significant. This implies that these two variables influence the dividend payments of listed manufacturing firms in Nigeria. The coefficients of leverage and Market to book value are not statistically significant

The coefficient of leverage is negative but not statistically significant. High leverage is expected affects the dividend payment of firms, as this will reduce the dividend as the debt interest had to be paid from earning and profit after tax before dividend payment is considered. A high level of leverage will result in the stockholders- bondholders agency problems that arise when debt is risky also predict a negative relations between leverage and profitability (Fama and Miller(1972), Jensen and Meckling(1976). However, the non significance of the coefficient point to the fact that it is not a major determinant of dividend payment by corporate firms in Nigeria. The coefficient of growth measured by market to book value is positive but not statistically significant. High growth is expected to have a positive impact the dividend payment of firms. The regression results show that profit after tax and total distributable earnings are the major determinants of dividend policy of listed manufacturing firms in Nigeria. The results are consistent with previous findings in Nigeria by Oyejide (1976), Odife (1977), Izedonmi and Eriki [1996], Adelegan and Inanga, 2001, Adelegan (2000a and b, 2002a and 2003a) and Adediran and Alade (2013).

5. SUMMARY, CONCLUSION AND POLICY RECOMMENDATION

The study analysed the determinants of dividend policy of manufacturing firms in Nigeria from 2009 to 2010. Data on present and past dividend, profit after tax, total distributable earnings, leverage and market to book value of listed firm were analysed. Profit after tax and total distributable earnings are the major determinants of

dividend policy of manufacturing firms in Nigeria.-The study also shows that the manufacturing firms' ability to pay dividend depends on profit after tax and total distributable earnings of the firms. However, it points more to the fact that both the total distributable earnings and profit after tax determines the dividend payment of firms in Nigeria.

The study recommends that there is need for firms to improve on their performance and increase their profitability level in order to have enough that will be transfer to the general reserves for dividend payment, especially when there is recession in the economy as dividend payment is a key factor in growing investors confidence as well as in enhancing the market value of the firms.

REFERENCES

Adediran S A and Alade S O (2013). Dividend Policy and Corporate Performance in Nigeria. *American journal of Social and Management Sciences*. Vol. 4(2):71-77.

Adelegan, O.J (2000a): Corporate Dividend Policy in Nigeria: 1984-1997, unpublished M.Sc (Econ) thesis, Department of Economics, University of Ibadan, 2000.

Adelegan, O.J (2000b): Impact of Growth Prospect, leverage and firm size on Dividend behaviour of Corporate Firms in Nigeria, 3th Annual conference of the Centre for the Study of African Economies on Opportunities in Africa: Micro-evidence on firms and households from April 9th-10th, 2000 at St. Catherine's College, University of Oxford, **abstract published on www.csaconference2000.org**.

Adelegan, O.J and Inanga E.L (2001): A Contextual Analysis of the determinants of Dividend Patterns of Commercial Banks in Nigeria, 24th Annual European Accounting Association Congress in Athens, Greece between April 18-20, **abstract published** on www.eaa-online.org

Adelegan, O.J. (2002a): "Dividend Payout, Retention Structure and Investment Pattern of Corporate Firms in Nigeria", Shareholders' Voice, Vol. 1 (2), pp.16-18. (Nigeria).

Adelegan, O.J (2002b): "The Pecking Order Hypothesis and Corporate Dividend Pay-out: Nigerian Evidence", African Review of Money, Finance and Banking, pp. 75-94, Supplementary Issue of 'Savings and Development' 2002, (Milan, Italy).

Adelegan, O.J (2003a): "An Empirical Analysis of the relationship between Cash flow and Dividend Changes in Nigeria", African Development Review, vol. 15(1), June, pp.35-49, (Tunisia).

Adelegan, O.J (2003b): "Capital Market Efficiency and the Effects of Dividend Announcement on Share Prices in Nigeria", African Development Review, vol. 15(2&3), Dec, pp.218-236, (Tunisia).

Adelegan, O.J (2006a): "Market Reactions to Initiations and Omissions of Dividend on The Nigerian Stock Market", Ibadan Journal of the Social Sciences, University of Ibadan., vol. 4, no1 (March), (Nigeria).

Adelegan, O.J. (2006b): "Price Reactions to Dividend Policy Changes on the Nigerian Stock Market", African Journal of Economic Policy, vol 13, no. 2, Dec., pp 59-79, (Nigeria).

Adelegan, O.J (2009): "Price Reactions to Dividend Announcements on the Nigerian Stock Market", African Economic Research Consortium (AERC) Research Paper No 188, pp. 1-32. (Nairobi, Kenya).

Adesola W A and Okwong A E (2009). An Empirical Study of Dividend Policy of Quoted Companies in Nigeria. *Global journal of Social Sciences* Vol. 8 (1), 2009:85-101

Al-Kuwari,D (2009). Determinants of the dividend policy in emerging stock exchanges: the case of GCC countries. *Global Economy & Finance Journal* Vol. 2(2):38-63.

Afzal,T and Mirsa, H (2010). "Ownership Structure and cash flow statements as determinants of corporate dividend policy in Pakistan". *International Business Research*, Vol.3(3): 210-221

Ahmed and Javid (2009). "Determinants of the dividend policy in Pakistan" *International Research Journal of Finance and Economics*. Issue 29: 110-125

Akbar M & Baig H H (2010) "Reactions of stock prices to dividend announcements and market efficiency in Pakistan". *The Lahore Journal of Economics*. Vol 15(1): 103-125.

Al-Kuwari (2010) To pay or not to pay: Using emerging Panel Data to identify factors influencing corporate dividend payout decisions. *International Reseach Journal of Finance and Economics*, Vol 42.

Amidu M & Abor J (2006). "Determinants of dividend payout ratio in Ghana" *The Journal of Risk Finance*. Vol 7(2): 136-145

Ashiq Alli and Kelsey Wei (2011)" The relationship between dividend changes in high versus low premium years

Gul S, Sajid M et al (2012) "The Relationship between Dividend Policy and Shareholder's Wealth. *Economics and Finance Review*. Vol.2(2): 55-59.

Kanwal and Kapoor,S (2008). "Determinants of Dividend Payout ratios- A study of Indian FMCG sector"

Malkawi (2007) "Determinants of Corporate Dividend Policy in Jordan: An application of the Tobit model

Malik Fakhra, and Sajid Gul (2013). "Factors influencing corporate dividend payout decisions of financial and non financial firms". *Research Journal of Finance and Accounting*. Vol 4(1).

Mehta (2012). An empirical analysis of determinants of dividend policy- Evidence from UAE companies. *Global Review of Accounting and Finance*. Vol 3(1):18-31

Nnadi M A & Akponi M E (2008) The effect of tax on dividend policy of banks. *International Research Journal of Finance and Economics*. Vol. 19 Sept (48-55)

Nwidobie D M Agency Conflict and corporate dividend policy decisions in Nigeria. *Asian Economic and Financial Review*, 2013. Vol 3(8): 1110-1121.

DeAngelo, Harr & DeAngelo, Linda & Stuz, Rene M (2006) "Dividend policy and the earned/ contributed capital mix: a test of the life- cycle theory". *Journal of Financial Economics, Elsevier*, Vol.81 (2):227-254

Nwidobie Barine Michael. (2013) Agency conflict and corporate dividend policy decisions in Nigeria. *Asian Economic and Financial review, Asian Economic and Financial society*, vol 3(8) :110-1121, August.

Appendix: Highlights of literature review

Author	Data/Country	Results/Findings
Akbar & Baig (2010)	Companies listed on Abu Dhabi Stock Exchange	Profitability and size are the most important consideration of dividend payout decisions.
Fakhra Malik and Sajid Gul (2013)	Determinants of dividend policy of firms listed on the Karachi stock exchange and are part of KSE-100 index, over the period 2007 to 2009.	liquidity, leverage, Earnings Per Share (EPS), and size are positively related to dividend.
Amidu and Abor (2006).	Determinants of dividend payout ratio on the platform of financial statements of accepted companies in African exchange within a six year period.	There is positive association between profitability and dividend policy and liquidity and dividend policy.
Ahmed and Javid (2009)	Sample of 320 non-financial companies listed in KSE from 2001-2006	Pakistani companies fix their dividend payments through past dividends and current earnings. More dividends are paid by stable companies.
Malkawi (2007)	Determinants of corporate dividend policy in Jordan for a period between 1989 and 2000.	Size, age and profitability of the firms have been found to be the determinant factors of corporate dividend policy in Jordan.
Nwidobie Barine	Dividend policy	Dividend policies of

Michael. (2013)	determinants of quoted firms in Nigeria	quoted companies in Nigeria are not aimed at solving the existing agency problems in these firms.
Nnadi and Akpomi (2008)	Studied implications of dividend policy in developing economies, particularly Africa	showed a significant effect of profit on dividend and a positive between tax, profit and dividend.
Ashiq Ali and Kelsey Wei (2011)"		
Abdelsalam et al (2008)	Dividend policy of 50 listed firms in Egypt for the period 2003-2995.	Significant positive association existed between institutional ownership and firm's efficiency.
Nwodibie, B M(2013)	Studied twenty five quoted companies in Nigeria.	There is a significant positive relationship between dividend policies of organizations and profitability, investments and earnings per share.
Adesola W A and Okwong A E (2009)	Dividend behaviour of a cross section of 27 Nigerian quoted companies between 1996-2006.	Share market price is a representation of market valuation of dividends.
Adediran S A and Alade S O (2013)	studied twenty five quoted companies in Nigeria	There is significant positive relationship between dividend policies of organizations and

		profitability, investments and earnings per share.
--	--	--

**MANAGERIAL OWNERSHIP AND DIVIDEND PAYOUT
POLICY IN NIGERIAN LISTED NON-FINANCIAL FIRMS
– Kajola, S. O. & Adewumi, A. A.**

**Department of Accounting,
Federal University of Agriculture, Abeokuta, Nigeria
E- mail: omobaaseye@yahoo.com. Tel No: 234-8033519371.**

**Adewumi, Ademola A
Department of Accounting,
Federal University of Agriculture, Abeokuta, Nigeria
E- mail: demobox4u@yahoo.co.uk. Tel No: 234-8036849833.**

&

**Babatolu, Ayorinde T
Department of Accounting,
Federal University of Agriculture, Abeokuta, Nigeria
E- mail: ayorinde.tobi@yahoo.com. Tel No: 234-8069033533.**

Abstract

Separation of ownership from control is the hallmark of modern joint stock companies. Shareholders as the owners of a business entity (the principal) entrust the day-to-day running of the entity in the hands of management (the agents). The agents, because of their lust for perks of office, may decide to act against the interest of their principals by engaging in activities that are detrimental to the interest of the owners but which profit them (agents). This results in agency problem between the two parties. The principals incur high monitoring cost in order to mitigate the agency problem. Dividend payment is seen as one of the tools for mitigating the agency problem. This paper examines the relationship between managerial ownership and dividend payout policy using sample of thirty non- financial firms listed on the Nigerian Stock Exchange during the eight- year period, 2006- 2013. Panel data for the selected firms were generated and analyzed using Fixed and Random Effects models. The regression result shows that a firm's managerial share ownership has positive and significant impact on the firm's dividend payout policy. The study by this finding indicates consistency with some prior empirical studies and provides support for alignment of interest hypothesis. It is hereby recommended that management should put in place robust dividend payout policies for their firms while the regulatory and policy makers develop sound corporate governance mechanisms that will protect minority shareholders from managers who have the potential to expropriate the benefits of their firms to them at the expense of other shareholders.

Key words: Managerial share ownership, Agency costs, Dividend policy, Alignment hypothesis, Signaling.

* Corresponding Author

1.0 INTRODUCTION

1.1 Background to the study

Aside capital structure decision, dividend policy is one of the most discussed topical issues in financial management/ corporate finance literature. What portion of the firm's profit is to be distributed as dividends and the part to be retained by the management for future investment? What factors influence dividend payout policies of

firms? What is the relationship between dividend payout policy and firm performance? These are well documented in the literature. But the debates on these issues continue.

Recently, attention of researchers has shifted from the above discourse to the agency theory of dividend policy. In a modern joint stock enterprise, the owners of the business (shareholders) are separate from the people that manage the business, managers. Managers of firms, according to Jensen and Meckling (1976), are agents of the shareholders and there is tendency for the managers to work against the interest of the shareholders by taking some actions that profit them at the expense of the shareholders. In a bid by the owners to see that managers take actions that will favour them (owners), they incur monitoring or agents cost. Dividend policy is seen to diminish the agency costs that arise as a result of the conflict between the managers and shareholders. This is because if dividends are not paid, the managers may use the available fund to invest in negative NPV projects, which will be against the interest of the shareholder but will benefit them (managers).

The present study seeks to examine the relationship between managerial ownership and dividend payout policy of selected non-financial firms in Nigeria. There is paucity of studies in this area of dividend policy decision in Nigeria and other developing countries. Earlier dividend policy studies in Nigeria concentrated mostly on its determinants and effects on financial performance. Some of these studies are Soyode (1995), Odedokun (1995), Oyejide (1976), Adelegan and Inanga (2001), Adelegan (2003), Sanda, Mikailu and Garuba (2005), Musa (2009), Uwuigbe, Jafaru and Ajayi (2012), Adediran and Alade (2013), Oyinlola, Oyinlola and Adeniran (2014), Osegbue, Ifurueze and Ifurueze (2014) and Kajola, Adewumi and Oworu (2015). The present study tries to reduce the knowledge gap by using the Nigerian business environment as a case study.

The rest of the paper is organized as follows: Section 2 discusses on the literature review. In section 3, the methodology of the study is considered. Data analysis and discussions are made in section 4, while section 5 concludes the study.

1.2 Research objective and justification for the study

The paucity of empirical studies in this area of dividend policy is the motivation for this study. The primary objective of this study is to examine the relationship between managerial ownership and dividend payout policy of 30 listed non-financial firms in Nigeria. It is hoped that the outcome of this study will be useful to managers of business entities, shareholders, bondholders, academics, finance professionals and the general reading public.

2.0 LITERATURE REVIEW

2.1 Theoretical framework

Agency cost theory: This theory has its root from the classical work of Berle and Means (1932) but made prominent by Jensen and Meckling (1976), is the major framework on which this study is premised. The theory argues that managers as agents of shareholders may have their interests conflicting with that of their principal. Since managers are said to favour pecks of office and power even at the expense of shareholders' interest, they are likely to pursue interests that may hurt their principals (shareholders).

Dividend payment is seen as a way by which powers of the managers to steal the fortune of the company is reduced. When they pay dividend as at when due, there will be less fund available to be stolen. This will of course involve a lot on monitoring on the part of the shareholders, resulting to agency costs.

Another area of conflict occurs between the large shareholders and the minority shareholders. This is predicted by the expropriation hypothesis which says that high level of ownership concentration increases the propensity for expropriation of minority shareholders by large shareholders (Shleifer and Vishny, 1997). Therefore, the controlling shareholders with substantial power adopt a payout policy that benefits only them at the expense of minority shareholders by paying out less dividends and retaining a larger amount of profit that they can expropriate. The rate of expropriation is better imagined if it happens that the largest shareholders are the managers (inside directors).

Signaling Hypothesis: This hypothesis indicated that dividend announcements have valuable information, known as signals, relating to future earnings of the firm. An increase in the level of dividend payout, according to this hypothesis, sends a positive signal to the investors and the general public that the future earnings of the firm is bright. The reverse is the case for a firm that reduces its dividend payout or did not even pay dividends. Regarding ownership control, insiders of firms with high managerial control are aware that outsiders associate ownership characteristic with high agency problems. Therefore, it is in the best interest of these firms to do something that can signal low agency conflicts. Payment of high dividends serves this purpose. Pettit (1977), Grossman and Hart (1980), Asquith and Mullins (1983), Nissim and Ziv (2001), Travlos, Trigeorgis and Vafeas (2001) and Bali (2003) provided evidence consistent with the prediction of this hypothesis.

2.2 Related empirical studies

Many empirical studies have been done about the relationship between ownership characteristic (proxies by managerial ownership, ownership concentration, institutional share ownership, foreign ownership or family ownership) and dividend payout policy such as:

Eckbo and Verma (1994) empirically show that dividend decreases with the increasing power of managerial ownership. They further argue that in the managerial controlled firms (where the managers have absolute voting power), the cash dividend is zero.

Maury and Pajust (2002) investigate the relationship between ownership characteristic, proxied by largest shareholder shares and dividend payment of firms in Finland. Result indicates a negative relationship between the two variables.

Farinha (2003) using UK data of listed firms reports that when the insider (managerial) ownership goes beyond a specific level, the agency problem increases and this requires more dividend payment to decrease the agency problem.

Gugler (2003) investigates the impact of the kind and identity

of the largest shareholder (individuals, families, investors and government) on the dividend payment of 214 non-financial corporations in Australia during the period 1991- 1999. Finding indicates that when family shareholder was the largest shareholder, the dividend decreases and when government was the largest shareholder, the dividend increases.

Chen, Cheung, Stouraitis and Wong (2005) using data from 412 Hong Kong listed companies for the period 1995-1998 reveals a little relationship between family ownership and dividend policy. Only for small firms there is a significant negative relationship between dividend payouts and family ownership up to 10% of the company's stock and a positive relationship for family ownership between 10% and 35%.

Kouki and Guizani (2009) study the relationship between ownership concentration/government ownership and the dividend payout policy of firms listed on the floor of Tunisia Stock Exchange for the period 1995- 2001. Results indicate a direct relationship between ownership concentration/ government ownership and dividend policy and there is a diverse relationship between the institutional investors and the payout ratio.

Ahmed (2009) examines the relationship between level of managerial ownership concentration and agency conflict which are proxied by level of risk, firms leverage and firms dividend policy of 100 listed firms in Malaysia for 1997- 2001. With the use of logit model, findings suggest a positive and significant association between level of risk at lower level of managerial ownership while a negative and significant association is also evidenced between risk at higher level and managerial ownership concentration. Furthermore, the result reveals that dividend policies, which also serve as monitoring mechanism to mitigate agency problem do not appear to have any significant impact on managerial ownership.

Mehrani, Moradi and Eskandar (2011) examine the relationship between ownership structure and dividend policy in Tehran Stock Exchange for the period 2000- 2007. Results reveal that institutional ownership has a negative relationship with dividend payout; positive relationship between dividend payout and concentrated institutional

ownership and no significant relationship between managerial ownership and dividend payout.

Ulla, Fida and Khan (2012) investigate the determinants of corporate dividend policy in the context of agency relation of a sample of seventy firms listed on the Karachi Stock Exchange for the period of eight years, 2003- 2010. Stepwise multiple regression was used to investigate the relationship of ownership variables with the dividend payouts. The results suggest a negative relationship between the dividend payouts and managerial share ownership. The result further reveals a positive relationship between institutional and foreign share ownership with dividend payout variables.

Agunaou, Farooq and Di (2013) investigate the effect of ownership structure on dividend policies for firms listed at the Casablanca Stock Exchange for the period 2004 – 2010. Results show that two forms of ownership identity influence negatively the dividend policy of firms listed. It further reveals that when the identity of the largest shareholder is either an industrial company or a family, the level of distributed dividends is decreased. The study also shows no impact of ownership concentration on the dividend policies of the sampled firms.

Al-Nawaiseh (2013) investigates the link between ownership structure and dividend policy of 62 industrial companies listed in Amman Stock Exchange from 2000- 2006. Tobit model and Ordinary Least Squares (OLS) were used to estimate the coefficient of the explanatory variables. Result shows that ownership dispersion as measured by the natural log of the number of stockholders has no significant relationship with dividend policy in Jordan. Furthermore, the fraction held by insiders (managerial ownership) has negative impact on the level of dividends paid while institutional ownership has a positive and significant influence on the dividend policy.

Other studies that show negative relations between ownership characteristic, particularly managerial share ownership and dividend payouts, include Jensen, Solberg and Zorn (1992), Short, Hao and Kevin (2002) and Wen and Ja (2010).

3.0 METHODOLOGY

3.1 Data source

Data for this study were mainly from secondary source. They were obtained from the published financial statements of the sample firms.

3.2 Population and sample

The population of the study comprises all the listed companies on the floor of the Nigerian Stock Exchange since inception in 1960 (186 as at December 2014). The study makes use of a sample of 30 non-financial firms (see Appendix I) obtained through the process of stratified random sampling technique. The financial firms were excluded because of their specific behaviour. The period of study is 8 years. This represents 240 firm-year observations.

3.3 Data instrument

Panel data methodology, which simultaneously combined cross-sectional data with time series data, was adopted for this study. Pooled Ordinary Least Squares, Fixed and Random effects models were used to estimate the coefficients of the explanatory and control variables. With the use of Hausman's specification test, the best technique for inferences is shown.

3.4 Variable description

Dependent variable: Many researchers in empirical financial management studies used dividend payout to proxy for corporate dividend policy. This study also follows the line of direction of the previous studies. Dividend payout is measured by the ratio of dividend paid to profit after tax. This is also the same as dividend per share.

Independent variable: Managerial ownership is the only independent variable. This is the most commonly used in the literature (see Welch, 2003, Sanda et al, 2005, Uchida, 2006, Park and Jang, 2010, Wahla, Shah and Hussain, 2012, Ehsan, Tabassum, Akram and Nazir, 2013, Aguenau, et al, 2013 and Kajola, et al 2014). Regarding the direction of the relationship between ownership characteristic (managerial ownership) and dividend payout, there is

no acceptable conclusion yet. However, many researchers, such as Afzal and Mirza (2010) and Din and Javid (2011) found a negative relationship and in support of agency cost and entrenchment hypotheses. Some other studies, such as Grossman and Hart (1980), Aivazian, Booth and Cleary (2003), Kumar (2004) and Ahmed and Javid (2008), produced positive relationship and in support of alignment hypothesis.

Control variables: Three variables that are capable of influencing the dividend payout policy are used in this study to control the dependent variable. The control variables are:

(i) Profitability: This is the mostly used control variable in the literature. The Return on Asset (ROA) is used as a proxy for profitability in this study. It is measured by the ratio of profit before interest and tax to total assets. Companies and Allied Matters Act, 2004 specifies that dividend can only be paid out of profit. *Ceteris paribus*, profitable firms will pay high dividends, hence positive relationship between profitability and dividend payout is expected.

(ii) Leverage: This is measured by the ratio of total debt to total assets. Shareholders wealth can be increased if the managers use the debt judiciously and invest in positive NPV projects. However, more use of it can lead to high financial risk which might affect dividend payout to shareholders because the fixed interests of the debt holders must be satisfied by the management before the shareholders. The fixed charges (interest payment to debt holders) also reduce free cash flows available to managers. Fama and French (2001), Grullon and Michaely (2002) and Ehsan, et al (2013) found negative relationship between leverage and dividend payout in their studies. Wallgern (2006) however found no relationship between the two variables.

(iii) Firm size: This is measured as the logarithm of total assets. Theoretically, large firms acquire more assets and are able to pay more dividends. Cash flows of large companies are stable and the firms are able to invest in different line of businesses that are profitable. Empirically, Fama and French (2001) and Grullon and Michaely (2002) provided support for the positive relationship. Thus,

we expect a positive relationship between dividend payout and firm size.

3.5 Hypothesis

The research hypothesis for this study in null form is:

Ho: There is no significant relationship between managerial ownership and dividend payout policy decision of Nigerian firms.

3.6 Model specification

The model for this study is in line with previous studies in the literature and is stated as follows:

$$DPO_{it} = \beta_0 + \beta_1 OWN_{it} + \beta_2 PROF_{it} + \beta_3 LEV_{it} + \beta_4 SIZ_{it} + e_{it} \quad (3.1)$$

Where,

$$DPO \text{ (dividend payout)} = \frac{\text{Dividend paid}}{\text{Profit after tax}} \quad (3.2)$$

$$OWN = \text{Managerial ownership} = \frac{\text{Directors equity shares}}{\text{Total outstanding equity shares}} \quad (3.3)$$

$$PROF \text{ (profitability)} = ROA = \frac{\text{Profit before interest and tax}}{\text{Total assets}} \quad (3.4)$$

$$LEV \text{ (leverage)} = \frac{\text{Total debt}}{\text{Total assets}} \quad (3.5)$$

$$SIZ \text{ (firm size)} = \text{Logarithm of total assets} \quad (3.6)$$

$\beta_1, \beta_2, \beta_3, \beta_4$ = Coefficients of the explanatory/ control variables
 e_{it} = error terms

3.7 Validity and reliability

Data for this study were obtained from published annual reports of the sample firms. These reports were audited by professional accountants and also meet the requirements of the Companies and Allied Matters Act 2004, the Nigerian Stock Exchange

and the Securities and Exchange Commission. The research instruments are not significantly different from those that were used by previous writers in both the developing and developed countries and are found suitable for this study.

4.0 RESULTS AND DISCUSSION

4.1 Descriptive statistics

Table 1 presents the descriptive statistics of the variables used in the study. The mean dividend payout for the sample firm is 40.7 kobo on every N1. Average managerial share control is about 6.9%, while the mean profitability is 9.1 kobo on every N1 asset of the sample firms. On the average the selected firms adequately utilized debt capacity during the period of study.

Table 1: Descriptive statistics

	Mean	Minimum	Maximum	Standard deviation	Skewness	Kurtosis
DPO	0.407	0.000	1.597	0.341	1.343	2.116
OWN	0.069	0.000	0.761	0.147	3.278	11.607
PROF	0.091	-0.090	0.510	0.068	0.630	5.806
LEV	1.492	0.000	23.200	3.705	3.573	13.609
SIZE	9.805	0.133	11.020	1.445	-5.123	31.746

Source: Authors' computation with the use of E- Views 7.0

4.2 Multicollinearity test

In order to make correct inferences from econometric analysis to be conducted, there is need for the test of multicollinearity test among the variables. We use three different methods to achieve this. Gujarati (2003) and Rumsey (2007) submit that coefficient value of 0.8 and above for an explanatory (independent) variable indicate existence of high multicollinearity problem between it and other variable. Furthermore, Gujarati (2003) posits that Variance Inflation Factor (VIF) and Tolerance value can also be used to test multicollinearity problem. A variable with VIF of above 10 or Tolerance value of less

than 0.1 shows existence of high multicollinearity between it and other variables.

Table 2 presents the result of the multicollinearity test among the variables used in the study.

Table 2: Multicollinearity test

Variable	VIF	Tolerance value
OWN	1.058	0.945
PROF	1.074	0.931
LEV	1.076	0.929
SIZ	1.028	0.973

Source: Authors' computation with the use of E- Views 7.0

From Table 2, none of the variables have VIF of above 10 or Tolerance value of less than 0.1. These results, thus, indicate that no problem of high multicollinearity is in the model.

4.3 Correlation

Table 3 presents the correlation matrix of the variables used in the study. From the Table, none of the variables has sig value of at least 0.80. This further shows the absence of high multicollinearity among the variables.

Table 3 indicates a positive and significant association between dividend payout (DPO), a proxy for dividend policy and managerial share ownership (OWN). This is contrary to the negative association shown by some prior empirical studies (see related empirical studies). However, it indicates that insider managers are aware that outsiders associate managerial ownership with high agency problems. Therefore, it is in the best interest of these firms to do something that can signal low agency conflicts. Paying high dividends, according to Aguenau et al (2013) is one such signal.

The Table 3 also shows a positive and significant association between dividend payout and profitability at 5% level. It means that profitable firms pay dividends. In other words, financial performance influences the dividend payout decisions of Nigerian firms. This is in line with some prior studies (Al-Kuwari, 2009, Afzal and Miza, 2010, Uwuigbe et al, 2012, Adediran and Alade, 2013, Oyinlola et al, 2014 and Kajola et al, 2015) and consistent with the provision of Nigerian Companies and Allied Matters Act, 2004.

A positive and insignificant association between dividend payout and leverage is shown in Table 3. Firm size has positive and significant association with dividend payout. It indicates that the larger the size of firm, the higher will be the dividend payment to owners of the business. This is consistent with earlier studies.

Table 3: Correlation matrix

	DPO	OWN	PROF	LEV	SIZ
DPO	1.000				
OWN	0.120** (0.032)	1.000			
PROF	0.810** (0.011)	-0.102* (0.058)	1.000		
LEV	0.019 (0.383)	-0.134** (0.019)	-0.214*** (0.000)	1.000	
SIZ	0.540** (0.020)	-0.138** (0.016)	-0.072 (0.133)	0.058 (0.187)	1.000

*, ** and *** indicate significant at 10%, 5% and 1% levels, respectively.

Sig values are shown in parentheses

Source: Authors' computation with the use of E- Views 7.0

Consistent with the prediction of pecking order theory, there is a negative and significant association between leverage and profitability as shown in Table 3.

A major limitation of coefficient matrix is its inability to predict the strength of the relationship between variables. It shows only direction of relationship. It is as a result of this that coefficient matrix alone cannot be used to make unbiased inferences, hence, the need for regression analysis.

The present study explores 3 different regression analyses- pooled ordinary least squares (OLS), fixed and random effects models. The short comings of pooled ordinary least squares, as documented in the literature, are the motivation for the conduct of the other two regressions.

4.4 Regression results

4.4.1 Pooled Ordinary Least Squares (OLS)

Table 4 presents the regression result using pooled OLS. From Table 4, the F-stat of 1.988 is significant at 10% level. It shows that the model as a whole is fit (though not strong enough). Durbin Watson value of 1.808 indicates less autocorrelation in the model.

From Table 4, there is a positive and significant relationship between dividend payout and managerial share ownership. It is consistent with the findings of Grossman and Hart (1980), Aivazian, et al, (2003), Kumar (2004) and Ahmed and Javid (2009). Jensen (1986) also provides support for the positive relationship when he documented that high dividend payments lessen agency costs by reducing free cash flows that could be spent on perks of office and unviable projects by the management.

Table 4: OLS Regression Result

Dependent variable: DPO

Variable	Co-efficient	t-stat	prob
Constant	0.139	0.868	0.386
OWN	0.348	2.279**	0.024
PROF	0.572	1.725*	0.086
LEV	0.005	0.894	0.372
SIZ	0.419	1.620*	0.094
R-square 0.33			
Adj R-square 0.16			
DW			
1.808			
F-stat			
1.988*			
(prob)			
0.097			
Observation 240			

*, ** and *** indicate significant at 10%, 5% and 1% levels respectively.

Source: Authors' computation with the use of E- Views 7.0

For the control variables, profitability and firm size, the Table 4 shows positive and significant relationship between them and dividend payout. It however shows positive but insignificant relationship between leverage and payout ratio.

In line with the position of Marfo-Yiadom and Agyei (2011) and Dawood, Moustafa and El-Hennawi (2011), regression with Fixed

effects and Random effects models where lagged values are not included among the regressors are applied. This will help to alleviate the endogeneity problem that may occur due to omitted variables, measurement error of explanatory variable or reverse causality between the dependent variable and the explanatory variables.

The fixed effects technique take into account the individuality of each firm or cross-sectional unit included in the sample by letting the intercept vary for each firm but assumes that the slope coefficients are constant across firms. Random effects model estimates the coefficients under the assumption that the individual or group effects are uncorrelated with other explanatory variables and can be formulated.

In order to determine which of the two analytical techniques is to be used for the purpose of making conclusion, the Hausman's specification test was conducted. The null hypothesis underlying the Hausman's specification test is that fixed and random effects models do not differ substantially. Empirically, if the prob value of the chi-square is greater (less) than 0.05, the estimation based on the Random effects (Fixed effects) will be better off.

Tables 5 and 6 present the Regression results with Fixed effects and Random effects models respectively.

4.4.2 Fixed Effects

From Table 5, the F-stat value of 4.355 and significant at 1% level indicates that the model as a whole is fit. It also has less autocorrelation (Durbin Watson value of 2.087). The Table further shows a strong, positive and significant relationship between dividend payout and ownership characteristic at 1% level. Of the three control variables, only firm size is positive and significant with dividend payout at 5% level, while others- profitability and leverage have insignificant relationship with dividend payout.

Table 5: Regression Result with Fixed effects

Dependent variable: DPO

Variable	Co-efficient	t-stat	prob
Constant	-0.057	-0.351	0.726
OWN	3.010	3.955***	0.000
PROF	-0.593	-1.584	0.115
LEV	-0.007	-0.819	0.414
SIZ	0.033	2.235**	0.027
R-square	0.47		
Adj R-square	0.36		
DW	2.087		
F-stat			
4.355***			
(prob)			
0.0000			
Observation	240		

*, ** and *** indicate significant at 10%, 5% and 1% levels respectively.

Source: Authors' computation with the use of E- Views 7.0

4.4.3 Random Effects

From Table 6, the dividend payout has a very strong positive and significant relationship with managerial share ownership at 1% level. It also has a positive relationship with firm size at 10 % level but a negative relationship with profitability at 5% level. It however has insignificant relationship with debt level (leverage). The model as a whole is fit (F-stat of 5.084 and significant at 1% level) and little or no autocorrelation (Durbin Watson value of 2.060).

Table 6: Regression Result with Random effects

Dependent variable: DPO

Variable	Co-efficient	t-stat	prob
Constant	0.020	0.130	0.896
OWN	2.859	4.085** *	0.000
PROF	-0.696	- 2.071**	0.040
LEV	-0.007	-0.850	0.396
SIZ	0.027	1.963*	0.051
R-square	0.45		
Adj R-square	0.36		
DW	2.060		
F-stat			
	5.084***		
(prob)	0.000		
Observation	240		

*, ** and *** indicate significant at 10%, 5% and 1% levels respectively.

Source: Authors' computation with the use of E- Views 7.0

4.4.4 Hausman's specification

The summary result of the Hausman's specification test is as shown in Table 7. From the table, the prob value is 0.2492 which is greater than 0.05. This result favours the use of Random effects model for making inference. Thus, our discussion will be based on the outcome of the study as shown in Table 6.

Table 7: Hausman specification result

Chi-square stat	Chi-square difference	prob
5.393977	4	0.2492

Source: Authors' computation with the use of E- Views 7.0

4.5 Discussion of findings

From Table 6, there is a positive and significant relationship between dividend payout (dividend policy proxy) and managerial share ownership (ownership characteristic proxy). It indicates that the management of the sample firms during the period of study understood the power of the signal which payment of dividends could make to outsiders, including new investors. In order to reduce the agency problem between them and the shareholders, they decided to pay high dividends. The positive relationship between the two variables as found in this study is also consistent with some prior studies (Grossman and Hart, 1980, Aivazian, Booth and Cleary, 2003, Kumar, 2004 and Ahmed and Javid, 2009) and provides evidence in support of dividend being use as a tool for mitigating agency problem between inside managers and other shareholders. The null hypothesis is hereby rejected in favour of the alternative hypothesis. Thus, there is a significant relationship between managerial share ownership and dividend payout policy decision of Nigerian firms.

For the control variables, a negative and significant relation occurred between profitability and dividend payout and positive relationship with firm size. Insignificant relationship is the result between dividend payout and leverage.

5.0 CONCLUSION, RECOMMENDATION AND FUTURE STUDY

5.1 Conclusion

The study empirically tested the relationship between dividend payout policy and managerial share ownership of 30 non-financial listed firms in Nigeria for the period 2006- 2013. With the use of Fixed effects and Random effects models, the regression result show a positive and significant relationship between dividend payout policy and managerial share ownership. The outcome of this study, although contrary to some prior studies that show negative result, finds support from some other studies and in line with financial theory

(signaling hypothesis) documented by Pettit (1977) and alignment of managerial incentives with shareholders interest. The latter might be as a result of the low levels of managerial share ownership (average of 6.9% as shown in Table 1). Furthermore, Grossman and Hart (1980) argue that dividend payouts alleviate agency conflicts through the reduction of free cash flow available to managers.

This study therefore submits that dividend payment can be used to mitigate the agency problems between managers (insider ownership) and other shareholders.

5.2 Recommendations

It is hereby recommended that firms should put in place robust dividend payout policies that will guarantee investment in positive NPV projects and which in turn will lead to high dividend payments to equity shareholders.

Regulatory bodies (such as Central Bank of Nigeria, Securities and Exchange Commission, Nigerian Stock Exchange, Nigerian Insurance Commission, etc) and policy makers are advised to develop sound corporate governance mechanisms that will prevent the insider- managers from expropriating the benefits to them at the expense of other stakeholders in firms they manage and at the same time part owners.

Representatives of minority shareholders should be appointed to the Board of Directors in order to be involved in the monitoring of Chief Executives and other management staff.

5.3 Future study

For future line of research, attempt should be made at increasing the sample size and the study period. Also, inclusion of some other variables, such as foreign ownership, family ownership, ownership concentration, institutional ownership as proxies for ownership characteristic will make the outcomes of such studies more robust.

References

- Adediran, S.A & Alade, S.O (2013). Dividend policy and corporate performance in Nigeria. *American Journal of Social and Management Sciences*, 4(2), 71-77.
- Adelegan, O (2003). An empirical analysis of the relationship between cash flow and dividend changes in Nigeria. *African Development Review*, 15(1), 35-49.
- Adelegan, O. J & Inanga, E (200 1). A contextual analysis of the determinants of dividend patterns of commercial banks in Nigeria. A paper presented at the 24th Annual European Accounting Association Congress in Athens, Greek.
- Afzal, T & Mirza, H (2010). Ownership structure and cash flows as determinants of corporate dividend policy in Pakistan. *International Business Research*, 3(3), 210-221.
- Aguenaou, S, Farooq, O & Di, H (2013). Dividend policy and ownership structure: evidence from Casablanca Stock Exchange. *GSTF Journal on Business Review*, 2(4), 116-121.
- Ahmed, H.J.A (2009). Managerial ownership concentration and agency conflict using logistic regression approach: evidence from Bursa Malaysia. *Journal of Management Research*, 1(1), 1-10.
- Ahmed, H & Javid, A. Y (2009). Determinants of dividend policy in Pakistan. *International Research Journal of Finance and Economics*, 29, 110-125.

Aivazian, V, Booth, I & Cleary, S (2003). Do emerging market firms follow different dividend policies from U.S. firms? *Journal of Financial Research*, 26(3), 371-387.

Al-Kuwari, D (2009). Determinants of the dividend policy in emerging stock exchanges: the case of GCC countries. *Global Economy & Finance Journal*, 2(2), 38-63.

Al- Nawaiseh, M (2013). Dividend policy and ownership structure: an applied study on industrial companies in Amman Stock Exchange. *Journal of Management Research*, 5(2), 83-106.

Asquith, P & Mullins, Jr, D. W (1983). The impact of initiating dividend payments on shareholders' wealth. *Journal of Business*, 56, 77-96.

Bali, R (2003). An empirical analysis of stock returns around dividend changes. *Applied Economics*, 35, 51-61.

Berle, A.A & Means, G.C (1932). *The Modern Corporation and Private Property*. New York, Macmillan.

Chen, Z.H, Cheung, Y, Stouraitis, A & Wong, A (2005). Ownership concentration, firm performance and dividend policy in Hong Kong. *Pacific-Basin Finance Journal*, 13, 431-449.

Companies and Allied Matters Act CAP. C20 Laws of the Federation of Nigeria, 2004.

Dawood, M.H.A.K, Moustafa, E. I & El-Hennawi, M. S. (2011). The determinants of capital structure in listed Egyptian corporations. *Middle Eastern Finance and Economics*, 9, 83- 99.

Din, S & Javid, A.Y (2011). Impact of managerial ownership on financial policies and the firm's performance: evidence from Pakistani manufacturing firms. *International research Journal of finance and Economics*, 81.

Eckbo, B & Verma, S (1994). Managerial share ownership, voting power and cash dividend policy. *Journal of Corporate Finance*, 1, 33-62.

Ehsan, S, Tabassum, N, Akram, Z & Nasir, R (2013). Role of insider and individual ownership structure in dividend payout policy: evidence from Pakistan. *Middle-East Journal of Scientific Research*, 17(9), 1316-1326.

E- Views 7.0 (2010): User's Guide.

Fama, E & French, K (2001). Disappearing dividends: changing characteristics or lower propensity to pay. *Journal of Financial Economics*, 60, 3-43.

Farinha, J (2003). Dividend policy, corporate governance and the managerial entrenchment hypothesis: an empirical analysis. *Journal of Business Finance and Accounting*, 30, 1173-1209.

Grossman, S.J & Hart, O.D (1980). Takeover bids, the free rider problem and the theory of the corporation. *Bell Journal of Economics*, 11, 42-54.

Grullon, G & Michaely, R (2002). Dividends , share purchase and the substitution hypothesis. *Journal of Finance*, 57, 1649-1684.

Gugler, K (2003). Corporate governance, dividend payout policy and the interrelation between dividends/ R & D and capital investment. *Journal of Banking & Finance*, 27, 1297-1321.

Gujarati, D (2003). *Essentials of Econometrics*. 3rd Edition, New York, McGraw-Hill.

Hausman, J. A (1978). Specification tests in econometrics. *Econometrica*, 46(6), 1215- 1271.

Jensen, M. C (1986). Agency costs of free cash flow, corporate finance and takeovers. *American Economic Review*, 76, 323-329.

Jensen, M. C & Meckling, W. H (1976). Theory of the firm managerial behaviour, agency cost and ownership structure. *Journal of Financial Economics*, 3, 305-360.

Jensen, G. R, Solberg, D. P and Zorn, T. S (1992): Simultaneous determination of insider ownership, debt and dividend policies. *Journal of Financial and Quantitative Analysis*, 27, 263-274.

Kajola, S.O, Adewumi, A.A & Oworu, O.O (2015). Dividend pay-out policy and firm financial performance: evidence from Nigerian listed non-financial firms. *International Journal of Economics, Commerce and Management*, III (4), 1-12.

Kajola, S.O, Abosedo, A.J & Akindele, J.A (2014). Ownership structure and firm performance. *Sokoto Journal of Management Studies*, 6(1), 40-59.

Kouki, M & Guizani (2009). Ownership structure and dividend policy: evidence from the Tunisian Stock Market. *European Journal of Scientific Research*, 25(1), 42-53.

Kumar, J (2004). Corporate governance and dividends payout in India. Working Paper on India's Financial System.

Marfo-Yiadom, E & Agyei, S. K (2011). Determinants of dividend policy of banks in Ghana. *International Research Journal of Finance and Economics*, 61, 99-108.

Maury, C.B & Pajuste, A (2002). Controlling shareholders, agency problems and dividend policy in Finland. *The Finnish Journal of Business Economics*, 51, 15-45.

Mehrani, S, Moradi, M & Eskandar, H (2011). Ownership structure and dividend policy: evidence from Iran. *African Journal of Business Management*, 5(17), 7516-7525.

Musa, I. F (2009). The dividend policy of firms quoted on the Nigerian stock exchange: an empirical analysis. *African Journal of Business Management*, 3(10), 555-566.

Nigerian Stock Exchange (2006-2013) *Fact Book*, Lagos.

Nissim, D & Ziv, A (2001). Dividend changes and future profitability. *Journal of Finance*, 56, 2111-2133.

Odedokun, M.O (1995). Dividend policy, investment spending and financing decisions: evidence from Nigerian quoted non- financial firms. *Nigerian Journal of Economics and Social Studies*, 37(3), 185- 202.

Osegbue, I.F, Ifurueze, M & Ifurueze, P (2014). An analysis of the relationship between dividend payment and corporate performance of Nigerian banks. *Global Business and Economic Research Journal*, 3(2), 75-95.

Oyejide, T. A (1976). Company dividend policy in Nigeria: an empirical analysis. *Nigerian Journal of Economics and Social Studies*, 18(2), July, 179- 195.

Oyinlola, O.M, Oyinlola, F.O & Adeniran, J.O (2014). The influence of dividend payout in the performance of Nigerian listed brewery companies. *International Journal of Economics and Management Sciences*, 3(1), 13-21.

Park, K.M & Jang, S.C (2010). Insider Ownership and Firm Performance: an Examination of Restaurant Firms. *International Journal of Hospitality Management*, 29(3), 448-458.

Petit, R.R (1977). Taxes, transaction costs and the clientele effect of dividends. *Journal of Financial Economics*, 5, 419-436.

Rumsey, D (2007). *Intermediate Statistics for Dummies*. Indianapolis, Wiley Publishing Inc.

- Sanda, A.U, Mikailu, A.S & Garba, T (2005). Corporate Governance Mechanisms and Firm Financial Performance in Nigeria, *AERC Research Paper 149*, Nairobi.
- Shleifer, A& Vishny, R.W (1997). A survey of corporate governance. *Journal of Finance*, 52, 737-783.
- Short, H, Hao, Z & Kevin, K (2002). The link between dividend policy and institutional ownership. *Journal of Corporate Finance*, 8(2), 105-122.
- Soyode, A (1975): Dividend policy in an era of indigenization: a comment. *Nigerian Journal of Economics and Social Studies*, 17(8), 126.
- Travlos, N, Trigeorgis, L & Vafeas, N (2001). Shareholder wealth effects of dividend policy changes in an emerging stock market: the case of Cyprus. *Multinational Finance Journal*, 5, 87-112.
- Uchida, K (2006). Agency Costs of Debt and the Relationship between Firm Performance and Managerial Ownership: Evidence from Japan. The Society for Economic Studies, University of Kitakyushu *Working Paper Series*.
- Ullah, H, Fida, .A & Khan, S (2012). The impact of ownership structure on dividend policy: evidence from emerging markets KSE-100 index. *Pakistan International Journal of Business and Social Science*, 3, 9.
- Uwuigbe, U, Jafaru, J & Ajayi, A (2012). Dividend policy and firm performance: a study of listed firms in Nigeria. *Accounting and Management Information Systems*, 11(3), 442-454.

- Wahla, K.U.R, Shah, S.Z.A & Hussain, Z (2012). Impact of Ownership Structure on Firm Performance: Evidence from Non-financial listed Companies at Karachi Stock Exchange. *International Research Journal of Finance and Economics*, 84, 6-13.
- Wallgren, A (2006). Dividend policy and ownership structure in Swedish firms. Unpublished Master's Thesis in Finance, Stockholm School of Economics.
- Welch, E (2003). The Relationship between Ownership Structure and Performance in listed Australian Companies. *Australian Journal of Management*, 28(3), 287-305.
- Wen, Y & Jia, J (2010). Institutional ownership, managerial ownership and dividend policy in bank holding companies. *International Review of Accounting, Banking and Finance*, 2(1), 8-21.

APPENDIX I: SAMPLE FIRMS

SECTOR	NUMBER OF FIRM
1: AGRIC/AGRO-ALLIED	1
2: AUTOMOBILE AND TYRE	1
3: BREWERIES	2
4: HEALTHCARE	2
5: TEXTILE	1
6: INDUSTRIAL AND DOMESTIC PRODUCT	3
7: BUILDING MATERIALS	3
8: CHEMICAL AND PAINTS	3
9: CONGLOMERATES	2
10. CONSTRUCTION	2
11: PRINTING AND PUBLISHING	2
12: FOOD/BEVERAGES & TOBACCO	3
13: PACKAGING	3
14: PETROLEUM (MARKETING)	2
TOTAL	30

THE IMPACT OF DIVIDEND POLICY ON THE SHARE PRICE OF SELECTED QUOTED FIRMS IN NIGERIA

BY

SALMAN, A. Y. (018739)*

LAWAL, A. A. (035164)**

ANJORIN, S. Y.***

* Principal Lecturer, Accountancy Department, The Federal Polytechnic Offa, Kwara State

Email: yekgold5@gmail.com

** Assistant Lecturer, Accountancy Department, The Federal Polytechnic Offa, Kwara State

Email: yomlaw2003@gmail.com

*** Assistant Lecturer, Accountancy Department, The Federal Polytechnic Offa, Kwara State

Email: lizzybabey01@gmail.com

THE IMPACT OF DIVIDEND POLICY ON THE SHARE PRICE OF SELECTED QUOTED FIRMS IN NIGERIA

Abstract

Despite years of theoretical and empirical research, dividend policy remains a source of controversy especially the aspect of the linkage between dividend policy and stock price. Its impact on shareholders wealth is still unresolved. This is in view of the fact that companies belong normally to different people or groups of people with individual views on the business and how to divide the firm's profit which in turn affects how each of these diverse investors place value on the firm. Hence, this paper investigated the impact of dividend policy on the share price of selected quoted firms in Nigeria. Dividend relevance and irrelevance theories were introduced in the study to capture the divergent views on the impact of dividend policy on stock price. The panel research design was adopted and secondary data drawn from the fact book of the Nigerian stock exchange and annual report of ten (10) selected companies for the period covering 1997-2012 was used for the study. The sample selection is based on a number of criteria employed by previous studies on dividend policy. Such criteria includes firms with the financial and market information available in the summarized reports necessary to estimate the various pooled panel data models amongst others criteria. A linear regression model was developed and statistically tested using panel least square method. The study concluded that the earning streams of companies in Nigeria have a greater impact than their dividend payouts in shaping the price of their shares in the market. The study therefore recommended that corporate managers should strive to maintain a steady increase in earnings by maximizing return on investment. The study further recommended that firms should maintain a stable dividend payout in order to increase internal finance available to pursue further profitable investments that will help increase earnings.

Keywords: Dividend Policy, Share Price, Quoted Companies, Nigeria

Introduction

The dividend policy of a company is a guideline that determines the proportion of earnings that is distributed to the shareholders by way of dividends, and the proportion that is ploughed back for reinvestment purposes. Dividend policy represents the payout policy, which managers pursue in deciding the size and pattern of cash distribution to shareholders over time (Davis, 2006). The main objective of financial management is to maximize the market value of equity shares, thus, one key area of study is the relationship between the dividend policy and market price of equity shares (Waithaka, Ngugi, Aiyabei, Itunga and Kirago, 2012). This objective translates into maximizing the value of the company as measured by the price of the company's common stock which can be achieved by giving the shareholders a "fair" payment on their investments.

However, the impact of firm's dividend policy on shareholders wealth is still unresolved (Black, 1976). There is a school of thought that advocates that the higher the dividend payout ratio, the more attractive the share is to shareholders (Gordon, 1959 cited in Al-Kuwari, 2009). This is not always true as some investors view firms that retained higher proportions of their profits as firms with strategic

investment opportunities. In this vein, another school of thought emanated in the literature suggesting that those firms who have viable investment opportunities should retain their profits and invest in such opportunities (Modigliani and Miller, 1961; Nissim and Ziv, 2001; De-Angelo, De-Angelo and Stulz, 2006). This is based on the premise that when a firm declares cash dividends, it indicates the lack of such investment opportunities and could be considered negatively thereby resulting in negative abnormal returns in the market share (Abubakar, 2010).

Thus, dividends are more than just a means of distributing net profit. This is because the dividend policy of a firm has implication for investors, managers and lenders and other stakeholders and variations in dividend payout ratio could affect share prices (Kapoor, 2012). For investors, dividends – whether declared today or accumulated and provided at a later date are not only a means of regular income, but also an important input in valuation of a firm. Similarly, managers' flexibility to invest in projects is also dependent on the amount of dividend that they offer to shareholders as more dividends may mean fewer funds available for investment. Lenders may also have interest in the amount of dividend a firm declares, as more the dividend paid less would be the amount available for servicing and redemption of their claims. A firm should therefore endeavour to establish an optimal policy that will maximize the value of the firm (Waithaka et'al, 2012).

Thus, there is no doubt that dividend policy is an integral part of the financial management decision of a business firm. Similarly, it is often said that the goal of any business is to earn profit and the division of this profit is an element of a firm's financial strategy. However, today companies belong normally to different people or groups of people with individual views on the business and how to divide the firm's profit between pay outs and retention. It, therefore, becomes difficult to make the most appropriate decision about the payout policy to be followed as it no doubt affects how each of the diverse investors place value on the firm. This poses a big problem for managers .For instance, some shareholders prefer to be paid dividends every year for investing in other profitable businesses while other shareholders would like to invest in the future and thus, prefer that the dividends be retained by the company for re-investment. Since firm's management deals with competing interests of various shareholders, the kind of dividend policy they adopt may have either positive or negative effects

on the share prices of the company. According to Miller and Modigliani (1961), the effect of a firm's dividend policy on the current price of its shares is a matter of considerable importance, not only to management who must set the policy, but also to investors planning portfolios and to economists seeking to understand and appraise the functioning of the capital market. It is this basis that prompted the study.

The following research questions became relevant from the problem identified: (i) Is there a statistically significant effect of dividend paid on market price of share? (ii) Is dividend payout the major determinant of share price? (iii) Does the impact of dividend policy on share price differ among the different sectors?

The general objective of this study is to examine the impact that a firm's dividend policy might have on its share price. However, the specific objectives of the study are to: (i) Examine the effect of dividend paid on the share price of quoted firms in Nigeria. (ii) Ascertain if dividend paid is the major determinant of share price of quoted firms in Nigeria. (iii) Determine if impact of dividend on share price is sector specific.

In line with the research questions raised, the following hypotheses were tested: H_{01} : Dividend paid has no statistically significant effect on the market price of shares of quoted companies in Nigeria. H_{02} : Dividend policy is not the major determining factor of the market price of shares of quoted companies in Nigeria. H_{03} : The impact of dividend policy on share price does not differ between different sectors of the economy.

Literature Review

Dividends are returns on investment to shareholders who have stake in the business of a firm (Kurfi, 2006). From the view point of these shareholders, dividends represent compensations for postponing consumption. Olowe (2009) sees dividend as distributions made out of a company's earnings after the obligations of all fixed income holders have been met. Malla (2009) viewed dividend as the profit made by the firm which is distributed to the shareholders. Every firm should decide whether to keep its profit as retained earnings or pay out as dividend. According to Kurfi (2006), dividend may take different forms such as cash dividends, scrip dividends, scrip issues, share split and share consolidation.

Dividend policy represents agreed guidelines which regulate management decision in sharing profit to shareholders (Ashamu, Abiola and Badmus 2009). Kurfi (2006) described dividend policy as a standard policy with respect to the payment of cash dividends. Pandey (1999) sees dividend policy as a decision by the financial manager whether the firm should distribute all profit or retain them or to distribute a portion and retain the balance. ICAN (2009) argued that the dividend policy of a firm relates to the various decisions on payment of dividend and states that the critical question in dividend policy is whether profits should be distributed as dividends or retained within the firm to finance future expansions and growth. Furthermore, ICAN (2009) believes that the pertinent questions to be answered in the formulation of any dividend policy should include; what will be the effect of either decision on value of the firm? If the company decides to pay dividends, how much should be paid and how much should be retained? If there are investment opportunities, should the firm use the monies available for dividend to finance these investments or should it pay dividends and borrow later to finance these investments? In answering these questions, different dividend policies have been adopted by different firms.

However, Chandra (2002) in his view of dividend policy posited that the dividend policy of a firm determines what proportion of earnings is paid to shareholders by way of dividends and what proportion is ploughed back in the firm for re investment purposes. According to him, if a firm's capital budgeting decision is independent of its dividend policy, a higher dividend payment will entail a greater dependence on external financing. Thus the dividend policy has a bearing on the choice of financing. On the other hand, if a firm's capital budgeting decision is dependent on its dividend decision, a higher payment will cause shrinkage of its capital budget and vice versa. In such a case, the dividend policy has a bearing on the capital budgeting decision.

Dividend policy, according to ICAN (2009), could either be passive or active. When a company follows a passive dividend policy, it means it is treating dividend payment as residual. This means that the determining factor as regards payment of dividend and how much to pay is the availability of profitable investment projects. These are projects with positive NPV. On the other hand, the active dividend policy regards dividend payment as a critical factor in the determination of the value of the firm and hence, the wealth of its

shareholders. This policy treats dividend payment not just as a way of sharing profits; it also looks at retentions as residue.

The factors that determine and shape the dividend policy of firms according to Malla (2009) includes legal requirements, liquidity position of the firm, firm's internal policies that enshrines the need to repay debt through retained earnings, restrictions enshrined in debt contracts and the tax position of shareholders.

The financial times, an online repository, views share price as the price of a particular company's share at a particular point in time. However, in [economics](#) and [financial theory](#), analysts use [random walk](#) techniques to model behaviour of [asset prices](#), in particular share prices on [stock markets](#), [currency exchange rates](#) and [commodity](#) prices. This practice has its basis in the presumption that investors act [rationally](#) and without biases, and that at any moment they estimate the [value](#) of an asset based on future expectations. In contrast, Lo & Mackinlay (1988) posits that empirical studies have demonstrated that prices do not completely follow random walks. They further submit that researchers have found that some of the biggest price deviations from random walks result from seasonal and temporal patterns. According to them, another school of thought known as [behavioural finance](#), attributes non-randomness to investors' cognitive and emotional biases.

When viewed over long periods, the share price is related to expectations of future earnings and dividends of the firm. Over short periods, especially for younger or smaller firms, the relationship between share price and dividends can be quite unmatched (Ehrhardt and Brigham, 2010). This creates the need to discuss the relationship between dividend policy and the value of the firm as measured by its share price.

On the relationship between dividend policy and the value of the firm, different schools of thought have emanated. These schools of thought can be grouped into two categories (Abdulraheem, 2010);

- a. Those that consider dividend decision to be irrelevant (Modigliani and Miller)
- b. Those that consider dividend decision to be an active variable influencing the value of the firm (Gordon and Lintner Uncertainty Resolution)

Modigliani and Miller (1961) as cited in Olowe (2009) provided the most articulate arguments on the irrelevance of dividend. According to

M-M, given the investment decision of a firm, dividend payout ratio does not affect shareholders' wealth. They believe that the value of the firm is determined by the streams of its earnings or its pattern of investment rather than pattern of distribution of its profits. Their contention is that as long as the firm has capital projects with positive NPV, it should continue to invest in them as this action will increase the value of the firm. The key assumptions that underlie the M- M theory are that: the firm operates in a perfect capital market in which all investors are rational, information is freely and equally available to all, no transaction cost e. t. c.

M- M asserted that the pattern in which the shareholder receives the dividend does not matter to him because with perfect market and condition of certainty, he can distribute the time pattern of the dividends to suit his wishes. He can borrow against future dividends if he wishes to consume at an earlier date than the receipt of the dividends. Therefore, the company is not doing for the shareholders anything they cannot do themselves and thus not creating value (Abdulraheem, 2010).

However, recognizing the fact that dividend policy does somehow affect stock prices, M – M suggest that the positive effects of dividends increase on stock prices are attributed not to dividend itself but rather to the informational content of dividend s with respect to future earnings (Kurfi, 2006)

Kurfi (2006) posited that a number of arguments have shown that in the absence of the restrictive assumptions of the M- M theory, their argument collapses. This is based on the fact that investors operate in a world of brokerage fees, taxes and uncertainties hence it is better to view the firm in the light of these factors.

On the other hand, Gordon and Lintner's theory have opposing view on the dividend policy in the perfect capital markets as argued by M-M (Jakub, 2007). The main idea of their theory is that even in perfect markets, the uncertainty of future situation is a sufficient reason to change the price of a share. Gordon (1959) argues that investors are generally risk averse and attach less risk to current as opposed to future dividends or capital gains. Therefore investors prefer to receive certain money today than to wait for gains from a questionable future investment. Hence, the dividend policy does matter. This forms the basis for the Bird in Hand theory propounded by Lintner (1956) and Gordon (1959).

Signalling theory originated from the information asymmetry between managers and shareholders. Supporting Lintners' (1956) model, Bhattacharya (1979) and Miller and Rock, (1985), cited in Jakub (2007) suggested that dividend announcements convey information about the future prospects of the firms. Due to the information content in dividends, dividend announcements are taken as a signal of the companies' good position that will raise the stock prices and vice versa. Signalling theory assumes that managers typically have more information about the value of the firm's assets than outside agents. Thus, Investors with imperfect information about company conditions would use dividends as a clue to the prospects of the companies.

Bird in Hand Theory

The traditional view of the theory of dividends is that dividends are the singular determinant of the value of shares and that the receipt of the share of profits now, in form of income rather than in the future, in form of capital appreciation, enhances the value of the share (ICAN 2009). The payment of dividend helps to resolve the uncertainty in the mind of investors about the future earning potentials of the company. Investors place greater reliance on the ability of the firm to earn profits in the future and pay dividends, reduce the risk perception of the company and this increases the value of the company's shares, all things being equal. Linked to the present study, this theory presupposes that dividend payout impacts on firm's share price because it reduces the uncertainty in the mind of the investors making them to discount the firm's return at a lower rate, thereby resulting into higher market values.

The literature on dividend policy has produced a large body of theoretical and empirical research, especially following the publication of the dividend irrelevance hypothesis of Miller and Modigliani (1961). However, general consensus is yet to emerge after several decades of investigation; and scholars often disagree even about the same empirical evidence (Al-Malkawi, Rafferty and Pillai, 2010).

Uddin and Chowdhury, (2005) in their study, selected 137 companies which were listed on Dhaka Stock Exchange (DSE) and studied the relationship between share price and dividend payout. The results showed that dividend announcement does not provide value gain for investors and shareholders experience approximately 20 % loss of value during thirty days before the announcement of dividend to thirty days following the announcement. He suggested that current dividend

yield can reimburse the diminished value to some extents. Generally, his findings supported the irrelevancy of dividend policy.

Muhammad (2010) in his study of the reaction of stock prices to dividend announcements in Pakistan tested the semi-strong form of market efficiency. His study analyzed cash, stock, and simultaneous cash and stock dividend announcements of 79 companies listed on the Karachi Stock Exchange from July 2004 to June 2007; and evaluated abnormal returns from the market model for statistical significance using the t-test and Wilcoxon Signed Rank Test. The findings from his study suggested negligible abnormal returns for cash dividend announcements, which inferred that the reaction of stock prices to cash dividend announcements in Pakistan is statistically insignificant.

In a study by Murhadi (2007) on the impact of dividend policy on share price in the Indonesian capital market based on the signalling theory using a multiple regression model on data gathered from a sample of 84 companies from 142 consumer product companies listed in main market of Bursa Malaysia for a period of six years from 2005 to 2010. The empirical results of this study showed significant negative relationship between share price volatility with two main measurements of dividend policy which are dividend yield and dividend payout.

Contrary to the above positions, some other studies are of the view that dividend policy is relevant in the determination of the value of a firm. Khan (2012) conducted research on the effects of dividend on stock prices and a data sample of twenty nine companies was taken covering the period 2001 to 2010. Fixed and random effect models were applied on the panel data collected. The result shows a significant positive relation between dividends, earnings per share and profit after tax to stock market prices

In a similar study, Joshi (2011) examined the impact of dividend on stock prices in Nepal. Secondary data was utilized for the study and the Least square regression model was adopted for data analysis. The result shows the positive effect of the dividend yields on share price volatility.

In Nigeria, studies have been conducted in the area of dividend policy and its relationship with liquidity, earnings and stock market returns. Adeyemi and Adewale (2004) evaluated the dividend practices among selected Nigerian quoted firms. Survey method was adopted in the study and a structured questionnaire was employed. . The result of the

survey questionnaires shows that Nigerian investors' attitudes are consistent with those of the bird-in-the-hand theorists and that Nigerian managers believe that dividend payouts have significant signalling effects both on share price and future prospects of a firm.

Adesola and Okwong (2009), in a similar study, made an attempt to evaluate the observed dividend policy of a cross section of 27 Nigeria quoted companies using theories tested to explain dividend behaviour of those firms. Data covering the period 1996 to 2006 were reviewed and a model with the necessary policy variables was constructed. Their study revealed that the traditional factors are significant in explaining and predicting their dividend decision within the period under review. The result provides strong support for the explanatory or predictive power of Lintner's model and confirms that share market price is a representation of market valuation of dividends.

Musa (2009) examined whether current earnings, previous dividend, cash flow, investment and net current assets have significant aggregate as well as separate impact on the dividend policy of a cross-section of 53 firms quoted on the Nigerian Stock Exchange (NSE) during the period 1993 to 2002. He used the five-variable parsimonious dividend policy model developed by Musa (2005). The study concluded that earnings, previous dividend and cash flow all have significant positive impact on the dividend policy of the quoted firms in Nigeria.

Although several literatures on dividend policy have produced a large body of empirical research, it was discovered that most of the empirical works carried out were in stock markets in developed economies. However, the few empirical papers in developing economies, especially Nigeria, were focused on the dividend practice of Nigerian companies as well as the relationship between dividend policy pursued by firms in Nigeria and their performance as measured by accounting profit. The author believes that empirical research in the area of the impact of dividend policy on share prices of firms in Nigeria is close to non-existence. This, the author believes, is important given the volatility of share prices in the stock market. The study also found out there was no study on the sectoral analysis of the impact of dividend policy on share price in Nigeria. Therefore, this study intends to fill these gaps by empirically testing the impact of dividend policy on share prices of firms listed on the Nigerian stock

exchange. In addition, the study will carry out a sectoral analysis of the impact of dividend policy on share prices.

Methodology

This study empirically investigated the impact of dividend policy on share prices of selected Nigerian quoted firms over a 15 year period. The study therefore adopted a panel research design method.

The study utilised data from the secondary source. This is because the estimation of the model in the study requires the use of pooled cross-section and time series data in the form of financial and market information. The sources of data for the study are therefore the Nigerian Stock Exchange (NSE) fact books for 1997 to 2012, daily official lists of the NSE for the study period, and the annual reports and accounts of the companies

The population of this study covers the 175 public companies quoted on Nigeria Stock Exchange (NSE). However, the study draws data upon a sample of 10 firms listed on the NSE for a fifteen year period (1997 to 2012) based on criteria adopted by previous similar studies. The choice of fifteen years is based on the fact that the period is long enough to adequately factor in events that occurred in the period before, during and after the crash in the stock market of 2008. The sample firms cover six (6) sectors among the thirteen (13) sectors as classified by the NSE. These are conglomerates, construction, consumer goods, financial services, industrial goods and oil and gas. The criteria upon which sample selection is based as employed by previous studies on dividend policy such as Casey and Dickens (2000) and Adelegan (2003) are;

- a. Firms with the financial and market information available in the summarized annual reports contained in the Nigerian Stock Exchange fact books, annual report of companies and daily lists of the NSE for the study period necessary to estimate the various pooled panel data models.
- b. Firms with record of current assets and current liabilities during the period of the study.
- c. Firms with record of dividend payment during the period of the study.

Model Specification

According to Chandra (2002), advocates of the traditional position cite the results of a cross – section regression analysis like the following:

$$\text{PRICE} = \alpha + \beta \text{ DIVIDEND} + \beta \text{ RETANED EARNINGS} \dots\dots\dots (1)$$

He stated that the traditionalist believe their model is vindicated because in any such regression analysis, the dividend coefficient will be much higher than the retained earnings coefficient. However, the study adapts the model above into a simple linear relationship as follows;

$$\text{MPS} = \alpha + \beta_1 \text{ DPS} + \beta_2 \text{ EPS} + \mu \dots\dots\dots (2)$$

Where

- α = Intercept
- β = Parameter estimate (coefficient)
- MPS = Market price per share
- DPS = Dividend per share
- EPS = Earnings per share
- μ = Error term

The a-priori expectation of the model is a positive relationship between the dependent variable and all the independent variable although it is expected that the dividend coefficient will be higher and more significant than other independent variables. To estimate the model, the Panel Least Square Method was used to regress the model on Eviews7.

Market price per share is the dependent variable. It is the current measure of the price of a share of stock based on information from a company's financial statements. The study made use of the selected firms' market share prices at exactly three months after accounting year ends. The reason behind the choice of these share prices is to ensure that the share prices adequately reflect the accounting information published by the selected firms (Abubakar, 2010).

Dividend per share represents the sum declared out of profits for each ordinary share issued. It is derived by dividing the total dividend declared during an entire year by the number of ordinary shares issued and ranking for dividend. The study made use of the dividend per share data extracted from the annual reports of the selected firms. As used in a similar study by Asadi (2013), dividend per share is an explanatory variable used as one of the proxies of dividend policy.

Earnings per share is another explanatory variable used as proxy for dividend policy (Asadi, 2013). It is the portion of a firm's profit allocated to each outstanding share of common stock. The study made use of the basic earnings per share figure contained in the annual

statement of the selected firm. It is derived by dividing the total earnings of a year by the number of ordinary shares issued.

Result and Discussion of Findings

Table 4.1 Descriptive Statistics Summary

	MPS	EPS	DPS
Mean	63.27863	3.619313	2.394625
Median	29.60000	2.060000	0.900000
Maximum	700.0000	26.67000	12.80000
Minimum	0.500000	-0.890000	0.000000
Std. Dev.	91.45051	4.254050	3.134893
Observations	160	160	160

Source: Author's computation (2015)

From table 4.1 above, the annual averages for MPS, EPS and DPS are ₦63.27, ₦3.61 and ₦2.39 respectively as depicted by their mean values. The maximum and minimum MPS during the period from 1997 to 2012 was ₦700 and ₦0.50 respectively. Similarly, the maximum and minimum EPS during the 15 year period was ₦26.67 and (₦0.89) respectively while that of DPS was ₦12.80 and ₦0.00 respectively. The dispersion in the series for MPS, EPS and DPS are 91.45, 4.25 and 3.13 respectively. This is relatively high confirming the fact that the variables are relatively unstable during the period.

Table 4.2: Result for Normality Test

	MPS	EPS	DPS
Skewness	3.289783	2.163255	1.528350
Kurtosis	18.82313	9.577918	4.642536
Jarque-Bera	1957.747	413.2513	80.27557
Probability	0.000000	0.000000	0.000000
Observations	160	160	160

Source: Author's computation (2015)

Table 4.2 above presents the result of the normality test conducted. The result showed that the data was not normally distributed as shown by the skewness and kurtosis values. This is because the decision rule is that normality is assumed when skewness is close to 0 and kurtosis is close to 2. Given that the variables of the study are not normally distributed, the ordinary least square method of panel data

regression model cannot be used (Gujarati and Porter, 2009). In that instance, either the random or fixed effects panel model should be adopted. The result also showed a Jarque- Bera statistics of 1957.74, 413.25 and 80.27 for MPS, EPS and DPS respectively with a probability of 0.0000 each. The decision rule is that the null hypothesis should not be rejected if probability is equal to or above 0.05 (Ahn, 2005).

Table 4.3: Result of Hausman Specification Test

Test Summary	Chi- Sq. Statistics	Chi- Sq d.f	Prob
Cross-section random	0.2348	2	0.8892

Source: Author's computation (2015)

Table 4.3 above shows the result of the Hausman specification test conducted to identify whether the random or fixed effect model should be adopted. The decision rule is that fixed effect should be used where the probability value is ≤ 0.05 . Otherwise the random effect should be adopted. The result of the test conducted shows a probability greater than 0.05. Therefore, the random effect model was adopted.

Table 4.4: Result of Granger Causality Test between Variables

Null Hypothesis	Obs	F-Statistic	Prob
EPS does not Granger Cause MPS	140		1.E-06***
MPS does not Granger Cause EPS		14.8517 8.23309	0.0004*
DPS does not Granger Cause MPS	140	7.49811 7.26689	0.0008* 0.0010*
MPS does not Granger Cause DPS			
DPS does not Granger Cause EPS	140	2.94602 1.96451	0.0559* *
EPS does not Granger Cause DPS			0.1442* **

Source: Author's computation (2015)

*Significant at 5% level of significance

** Significant at 10% level of significance

***Not significant at any conventional level

The result of the granger causality test shown in Fig 4.4 above indicates that there is no causal relationship between EPS and MPS, MPS and DPS and EPS and DPS. This implies that the trend of one series cannot be used to determine the other.

Table 4.5: Regression result for the impact of dividend policy on share price

Dependent Variable	MPS		
	Coefficient	t- statistics	Prob.
C	-4.2947	-0.7942	0.4283
DPS	4.5546	1.8571	0.0652 **
EPS	15.6567	8.7740	0.0000 *
R- squared	0.7224		
Adjusted R- squared	0.7189		
F- statistics	204.3282		
Prob. (F- statistics)	0.0000		
Durbin-Watson Stat	1.2942		

*Significant at 1% level

**Significant at 10% level

Source: Authors computation (2015)

From table 4.1 above, the model can be estimated as follows

$$MPS = -4.2947 + 4.5546DPS + 15.6567EPS \dots\dots\dots(3)$$

The estimated model confirms the a-priori expectation of the model. Earnings per share and dividend per share have a positive relationship with the dependent variable (MPS). In addition, the regression result shows that the estimated model is reliable because it has an R² of 0.7224. This implies that about 72% of the variations in market price per share (MPS) can be explained by the explanatory variables (DPS and EPS). The durbin Watson value is closer to 2 which is the standard confirming the absence of autocorrelation in the model. Similarly, for the overall significance of the model, the probability of the F statistics is significant at the 1% level as depicted by the p-value of F-statistics (0.0000). This implies that the model is good to fit.

However, by this regression result, the traditionalists' believe that the dividend coefficient will be higher than the earnings coefficient did not hold. This is because the regression result shows that whenever there

is a naira (₦1) increase in dividend, market price of shares will increase by over 400%. It also revealed that a naira (₦1) increase in earnings will lead to an increase of over 1500% in market price per share. This shows that in Nigeria, the earning streams of companies have a greater impact than their dividend payouts in shaping the price of their shares in the market. This result negates the resolve of the traditionalist. This perhaps could be as a result of the difference in the efficiency of the markets in which this study was conducted and the ones where the traditionalist conducted their study. The Nigerian economy is developing and its stock market can be described as a semi strong form of market efficiency whereas the traditionalist conducted their studies in developed economies whose market can be described as a strong form of market efficiency.

Furthermore, the result of the study invalidates the first hypothesis that states that dividend paid has no statistically significant effect on the market price of shares of quoted companies in Nigeria. This is because the result has shown that dividend paid significantly influences the market price of shares. However, the result validates the second hypothesis that states that dividend policy is not the major determining factor of the market price of shares of quoted companies in Nigeria. This is because the result has shown that, although dividend payouts influences share prices of firms, the earnings of firms influences their market price more than dividend payouts do.

The result of the study tends towards the M- M theory of irrelevance of dividend that posits that the value of a firm is determined by the earning power of the firm's asset and not its dividend policy. However, recognizing the fact that dividend policy does somehow affect stock prices, M – M suggest that the positive effects of dividends increase on stock prices are attributed not to dividend itself but rather to the informational content of dividend s with respect to future earnings. The result of this study is consistent with the findings of Uddin and Chowdhury, (2005) and Murhadi (2007).

Furthermore, the study embarked upon a sectoral analysis of the impact of dividend policy on share prices in Nigeria. This was with a view to see if there are peculiarities with respect to the impact of dividend policy in each of the sector analysed.

Table 4.6: Regression result for the Sectoral Analysis of the Impact of Dividend Policy on Share Price

	Consumer Goods (Brewery) Sector			Industrial Goods (Building Material) Sector			Oil and Gas (Petroleum Marketing) Sector		
Dependent Variable	MPS								
	Coefficient	t- stat	Prob.	Coefficient	t-stat	Prob.	Coefficient	t-stat	Prob.
C	0.507685	0.053579	0.9576	7.72845	3.016454	0.0099	79.47381	4.848034	0.000
DPS	5.102802	1.592329	0.1222	-0.745892	-0.233120	0.8193	-2.101253	-0.513728	0.616
EPS	12.59839	4.305027	0.0002*	5.750777	2.245189	0.0428**	6.447760	2.334858	0.036**
R-squared	0.760890			0.936475			0.925985		
Adjusted R-sq	0.744400			0.848518			0.823503		
F-statistics	46.14159			10.64692			9.035559		
Prob.(F-Stat.)	0.000000			0.000047			0.0000117		
Durbin-Watson	0.7315			0.75688			2.0681		

*Significant at 1% level ** Significant at 5% level

Source: Authors computation (2015)

From table 4.6 above, a model can be estimated for each of the sectors as follows:

Breweries sector

$$MPS = 0.507685 + 5.102802DPS + 12.59839EPS \dots\dots\dots(4)$$

Building material sector

$$MPS = 7.72845 + -0.745892DPS + 5.750777EPS \dots\dots\dots(5)$$

Petroleum marketing sector

$$MPS = 79.47381 + -2.101253DPS + 6.447760EPS \dots\dots\dots(6)$$

The estimated model for the brewery sector confirms the a-priori expectation of the model. The explanatory variables (EPS and DPS) have a positive relationship with market price per share which is the dependent variable. The result also shows that about 76 % of changes in the market price per share can be explained by the independent variables (EPS and DPS). This shows that the model is reliable. However, the result of this regression result is in consonance with the earlier result. It shows that it is the earning power of the firms in the brewery sector that drives their share prices. Dividends in this case are insignificant. This is also in contrast with the traditional view stated earlier.

The estimated model for the building material sector does not confirm the a-priori of the model. The result shows a positive relationship between earnings and market price of shares as expected. However, the result shows a negative relationship between dividend payout and share price which is in contrast with expectation of the model. However, the result of this regression result is fairly in consonance with the earlier results. It also shows that it is the earning power of the firms in the building material sector that drives their share prices. Dividends in this case are insignificant. This is also in contrast with the traditional view stated earlier.

The estimated model for the petroleum marketing sector does not confirm the a-priori of the model. The result shows a positive relationship between earnings and market price of shares as expected. However, the result shows a negative relationship between dividend payout and share price which is in contrast with expectation of the model. However, the result of this regression result is fairly in consonance with the earlier results. It also shows that it is the earning power of the firms in this sector that drives their share prices. Dividends in this case are insignificant. This is also in contrast with the traditional view stated earlier. Therefore the third null hypothesis that states that the impact of dividend policy on share price does not differ between different sectors of the economy is accepted. This is in view of the fact that the results of the sector analysed revealed that dividend payout has little or no significant impact on share prices of the companies in the sectors.

Conclusion and Recommendations

The paper empirically investigated the impact of dividend policy on the share price of selected quoted Nigerian firms using a linear regression model. This is as a result of the unresolved and divergent position of several studies on the impact of firm's dividend policy on share price. The study also conducted a sectoral analysis of the impact of dividend policy on share price to see if these impacts are sectoral specific. Literatures reviewed revealed that there is a school of thought that advocates that the higher the dividend payout ratio, the more attractive the share is to shareholders. Hence, investors place higher values on the shares of such firms. However, this is not always true as some investors view firms that retained higher proportions of their profits as firms with strategic investment opportunities. In this vein, another school of thought emanated in the literature suggesting that those firms who have viable investment opportunities should retain their profits and invest in such opportunities

The result of the empirical study carried out revealed that the earning streams of companies in Nigeria have a greater impact than their dividend payouts in shaping the price of their shares in the market. Similarly, the result of the sectoral analysis carried out also revealed that, in each of the sectors, earnings drives share prices the most. Practically, this implies that the market price of shares on the Nigerian stock exchange reacts more to earning capability of firms than they do to the dividend payout of the firms. This is in line with the M-M irrelevancy of dividend theory which posits that dividend payout ratio does not affect shareholders' wealth. Rather, the theory hinges on the belief that the value of the firm is determined by the streams of its earnings or its pattern of investment rather than pattern of distribution of its profits. However, this is not to say that the dividend policies of firms are completely irrelevant as the result shows a positive relationship between dividend payout and share price. The study therefore recommends that; (i) corporate managers should strive to maintain a steady increase in earnings by maximizing return on investment. This is in view of the fact that market price of shares in Nigeria is majorly influenced by level of earnings and, (ii) firms should maintain a stable dividend payout in order to increase internal finance available to pursue further profitable investments that will help increase earnings.

References

Abdulraheem, A. (2010) *Dividend Pay – Out and Bank Performance in Nigeria: 1998 – 2007*. Ph.D thesis, University of Ilorin, Nigeria.

Abubakar, S. (2010). *Dividend Payout Ratio and Share Price Movement of Listed Non Service Firms in Nigeria: Empirical Study* . Ahmadu Bello University, Zaria , Nigeria

Adelegan, O. J. (2003). *An Empirical Analysis of the Relationship between Cash flows and Dividend Changes*, A Paper Presented at the 23rd Annual Congress of the European Accounting Association, Munich, Germany.

Adesola, W. A. & Okwong, A. E. (2009). An Empirical Study of Dividend Policy of Quoted Companies in Nigeria. *Global Journal of Social Sciences*. 8(1). p.85-101.

Adeyemi, S. I. & Adewale A. A. (2004). *Evaluation of the Dividend Practices Among Selected Nigerian Quoted Firms*, University of Ilorin, Nigeria. Available from: <http://www.unilorin.edu.ng/index.php/en/publication-faculty-of-business-and-social-sciences/1143-adeyemi-s-i-business-administration> [Accessed: 18th September, 2014]

Ahn, A. (2005). Eviews Tutorial. Available from www.asu.edu [Accessed: 30th September, 2014}

Al-Kuwari, D. (2009). Determinants of the Dividend Policy in Emerging Stock Exchanges: the Case of GCC Countries. *Global Economy & Finance Journal*. 2 (2). p.38-63.

Al-Malkawi, H., Rafferty, M. & Pillai, R. (2010), Dividend Policy: A Review of Theories and Empirical Evidence, *International Bulletin of Business Administration*. 9(1). p.171-200.

Asadi, A. (2013). Examining the Relationship between the Dividend Policy and Stock Prices in Companies Listed on Tehran Stock Exchange. *Research Journal of Applied Sciences, Engineering and Technology*. 6(22). p.4186-419.

Black, F. (1976). The Dividend Puzzle. *The Journal of Portfolio Management*. 2(2). p.5-8

Casey, K. M, & Dickens, R. N (2000). Effects of Tax and Regulatory Changes on Commercial Bank Dividend Policy, *Review of Economics and Finance*. 40(2). p.9 - 33.

Chandra, P. (2002) *Financial Management Theory and Practice*. 5th Ed. New Delhi: Tata Mc Graw – Hill Publishing Company Ltd.

Davis, J. P. (2006). *What contributes to shareholder value?*, Duke and Rice Universities.

DeAngelo, H., DeAngelo, L., & Stulz, R. M. (2006). Dividend Policy and the Earned/Contributed Capital Mix: a Test of the Life-Cycle Theory. *Journal of Financial Economics*. 81(2). p.227–254.

Ehrhardt, M. C. & Brigham, E. F. (2010). *Corporate Finance: A Focused Approach*. London: Cengage Learning.–. [ISBN 9781439078112](#). [Accessed: 15th September 2014]

Gordon, M. J. (1959). Dividends, Earnings and Stock Prices. *Review of Economics and Statistics*, 41 (2). p.99-105.

Gujarati, N. and Porter, D. C. (2009). *Basic Econometrics*. New York: McGraw-Hill

Hashemijoo, M., Ardekani, A. M, Younesi, N. (2012). The Impact of Dividend Policy on Share Price Volatility in the Malaysian Stock Market. *Journal of Business Studies Quarterly*. 4 (1). p.111-129.

Institute of Chartered Accountants of Nigeria (ICAN) (2009), *Strategic Financial Management*. Lagos; VI Publishing Ltd.

Jakub, k. (2007). *The Influence of the Dividend Policy on the Market Share Price Volatility*. M.Sc. Thesis. Aarhus School of Business, Poland.

Kurfi, A. K. (2006). *Principles of Financial Management*. Kano: Benchmark Publishers Limited.

Lintner, J., (1956). Distribution of Incomes of Corporations Among Dividends, Retained Earnings, and Taxes, *American Economic Review*. 46. p.97-113.

Lo, A. W. & A. C. MacKinlay (1988). Stock Market Prices Do not Follow Random Walks: Evidence from a Simple Specification Test. *Review of Financial Studies* 1 (1): 41–66. doi:10.1093/rfs/1.1.41. ISSN 0893-9454.

Malla, B. B. (2009). *Dividend Policy and Its Impact on Share Price: Analysis Of Selected "A" Class Listed Companies*. M.Sc. thesis. Apex College Pokhara University, Nepal.

Meaning of Share price Available from: <http://lexicon.ft.com/Term?term=share-price> [Accessed: 15th September, 2014].

Modigliani, F. & Miller, M. H. (1961). Dividend Policy, Growth, and the Valuation of Shares. *American Economic Review*. 48 (3). p.261–297.

Murhadi, W. R (2007). *The Impact of Dividend Policy on Share Price Volatility in the Malaysian Stock Market*. Universitas Surabaya, Indonesia.

Musa, F. I. (2005). *Modelling the Dividend Behavioural Pattern of Corporate Firms in Nigeria*. Ph.D thesis. Ahmadu Bello University, Zaria. Nigeria.

Musa, F. I. (2009). The Dividend Policy of Firms Quoted on the Nigerian Stock Exchange: An empirical analysis. *African Journal of Business Management*, 3(10). p.555-566 Available from: <http://www.academicjournals.org/ajbm> [Accessed: 28th September, 2014]

Nissim, D. & Ziv, A. (2001). Dividend Changes and Future Profitability. *Journal of Finance*. 56. p.2111-2133.

Olowe, R. A. (2009). *Financial Management Concept, Financial System and Business Finance*. (2nd ed.). Lagos: Briely Jones Nigeria Limited.

Uddin, M. H., & Chowdhury, G. M.(2005). Effect of Dividend Announcement on Shareholders' Value: Evidence from Dhaka Stock Exchange. *Journal of Business Research*. 1(3). p.55-60

Waithaka, S. M, Ngugi, J.K, Aiyabei, J. K, Itunga, J. K & Kirago, P. (2012). Effects of dividend policy on share prices: A case of companies

in Nairobi Securities Exchange. *Prime Journal of Business Administration and Management*. 2(8). p.642-648.

THE LINK BETWEEN OIL PRICE FLUCTUATIONS AND THE MANUFACTURING SECTOR PERFORMANCE IN NIGERIA

Uguru, Leonard C.

Department of Accountancy,

Ebonyi State University, Abakaliki, Nigeria

e-mail: uguruleonard@yahoo.co.uk

Abstract

The paper examines the relationship between oil price fluctuations and the manufacturing sector performance in Nigeria, using the various tests for stationarity (ADF), Johansen Co-integration, Vector Error Correction Estimates and Granger Causality tests. The result shows that on their individual basis, oil price fluctuations, exchange rate volatility and interest rate are not significantly related to manufacturing sector performance; but the explanatory variables have significant joint influence on manufacturing sector performance in Nigeria. Therefore, it was revealed that oil price, exchange rate and interest rate have the potentials of causing significant effects on manufacturing sector performance in Nigeria. The importance of macroeconomic stability cannot be over emphasized if Nigeria's manufacturing sector performance is to be competitive in the international market. Also, more policy attention should be given to regulation of exchange rate and a steady interest rate in Nigeria.

Key Words: Oil Price, Exchange Rate, Interest Rate, Manufacturing Sector Performance.

Introduction

The need to promote a strong manufacturing sector has continued to be a major concern of the most developing economy. The

reason for this awakened interest in manufacturing sector can be traced to the fact that a significant improvement in the productivity level of manufacturing sector is a facilitator in a growing economy. Also, a significant increase in manufacturing sector performance offers prospect of growing availability of manufactured products, increase employment, greater efficiency, improved balance of payments and higher technological innovation (CBN, 2002).

However, despite efforts by past administrations in Nigeria at promoting manufacturing sector, and the corresponding effects of macroeconomic variables on the manufacturing development which should increase national income, per capital income, provide foreign exchange earnings, secure full employment and expand the market for local raw materials; manufacturing sector performance in Nigeria has been rather poor since independence. Prior to 1970, there was a real total reliance on agricultural production while the post 1970 era showed a total shift to exclusive reliance on crude oil. In addition to the monoculture structure of the production basis, there was the problem of oil price fluctuation, which to a large extent has adversely affected manufacturing sector productivity in Nigeria. The oil price is relevant in the performance of manufacturing sector bearing in mind that crude oil is the basic material for a wide range of products, such as lubricants, asphalt, tars, tires, solvents, plastic, foams, bubble gums, deodorants, crayons, and so on (Ojapinwa and Ejumedia, 2012). Despite the vast usefulness of oil products, statistics show that oil prices have risen significantly over the years. It is the views of Olapoenia, (2013), Okigbo, (2009) and Iwayemi, (2011) that since 1973, substantial fluctuations in the international price of crude oil have had far reaching implication on the industrial sector. The possible significance of oil prices for exchange rate movements have been noted by Nikbakht (2009) and Oriavwote and Eriemo (2012).

The price of crude petroleum rose from the first time in Nigeria in 1973 in response to the uncertainties created by the Arab- Israel war, which erupted in October 1973. During this period, the price of crude petroleum rose from \$3 to \$11.65 per barrel and the resultant upsurge in oil prices generated a total of 9.232 billion dollars in revenue for Nigeria in 1974 while the country exported 109 million tons of crude oil that year (Mandel, 1999). The upsurge in crude oil and price and the resultant increase in the revenue for the country

created opportunities for manufacturing sector development and modernization of the Nigeria economy.

Although, the oil price increase in 1973 was short lived, between 1979 and 1980, the price of oil rose in the international market between \$35 and \$40 a barrel. The rise in crude oil price again was only mainly to the Iranian revolution. Crude oil prices have increased on average from US \$25 per barrel in 2002 to US \$55 in 2005. In the middle of 2008, the increase in oil prices hit a high nominal record of US \$147 per barrel; but dropped sharply to US \$46 per barrel towards the end of the same year, 2008 (Ojapinwa and Ejumedia, 2012).

First Bank Business Report (1990) revealed that with increased revenue derivable from oil sector, the Nigerian economy became mono-cultural as emphasis shifted from the agriculture sector to oil sector. Thus, in 1980 the nation experienced severe economic crisis which is traceable to the over dependence on the oil sector (Olashere, 2008). The oil glut era of the 1980's created a serious problem for the manufacturing sector, as there was a decline in the performance and level of employment in this sector.

Consequent upon the freezing, the country passed through a period of structural adjustment programme in 1986. This was accompanied by austerity measure of enormous proportion. By 1990 a sign of relief was welcomed with the price of oil in the international market soared as a result of the Gulf war between Iraq and Kuwait. The revenue gained from the glut crises was however not translated to productivity. In the late 1990's and early 2000 crude oil maintained its position as the highest contributor to the federal account. This was shown in the year 2003 annual budget. Out of estimated revenue of ₦1,819,214 billion, a total of ₦1,201,789 billion representing 61.58% is expected to be generated from oil. The projection predicted on a crude oil price at \$21 per barrel. The answer to this question rest on the pattern of crude oil price volatility.

Spikes in oil price signal high cost of production as oil is a major input in production. Thus, growth of output and productivity are reduced when oil price exchange increase. While much work has been done concerning the impact of oil prices on rates in the oil exporting countries (Sibanda and Mlambo, 2014; Oriavwote and Eriemo, 2012;

Nikbakht, 2009), other scholars like Ojapinwa and Ejumedia (2012), Zhang (2008) and Rodríguez (2007) examine the industrial impact of oil price shocks, there is less evidence on studies on the relationship between oil price fluctuations and performance of manufacturing industry. Thus, the paper aims to examine the relationship between oil price variability and the manufacturing sector performance in Nigeria.

Empirical Literature

This section presents the various studies done, the methods used, the findings of the studies and the recommendations/conclusion made.

Rodríguez (2007) examines the response of manufacturing industrial output to an oil price shock in some selected countries of France, Germany, Italy, Spain, the United States, and the United Kingdom. The result revealed that oil price increase lowers the level of aggregate manufacturing output in all countries under study, although the pattern of response differs somewhat across countries.

Zhang (2008) applies Hamilton's (2001) approach to investigate the relationship between oil price shock and Japanese industrial production growth using quarterly data from 1957 to 2006 and finds that the oil price changes and macroeconomic activity in Japan appear to be affected by a non-linear relationship.

Nikbakht (2010) examined the link that exists between oil price and exchange rate using OPEC member states as a case study. The study employed monthly panel data of seven countries of OPEC membership from January 2000 to December 2007 to investigate the long run relationship. The findings of their study showed that oil prices are a dominant source of real exchange rate movements. The results also revealed that there is a long-run linkage between real oil prices and real exchange rates.

Ojapinwa and Ejumedia (2012) examines the industrial impact of oil price shocks in Nigeria from 1970-2009. The study adopted the econometric approaches of VAR impulse response. The findings of the study show that oil price, inflation and exchange rate has the potentials of causing significant changes in industrial output in Nigeria, while it was also revealed that industrial output was not significantly

determined by money supply. This study therefore suggests that more policy attention should be given to proper management of the exchange rate and inflation.

Oriavwote and Eriemo (2012) examined the link between the real oil prices and the real exchange rate. The study employed Johansen cointegration test and the Granger Causality test using Nigerian time series data for the period between 1980 and 2010. Their findings from the GARCH test suggest persistence of the volatility between the real oil prices and the real effective exchange rate.

Sibanda and Mlambo (2014) investigate the impact of oil prices on the nominal exchange rate in South Africa. The Generalized Autoregressive Conditional Heteroscedasticity (GARCH) test was performed to determine the impact of oil prices on nominal exchange rate using monthly time series data covering the period between 1994 and 2012. The results show that oil prices have a significant impact on nominal exchange rates. The study recommends that the South African government should consider the impacts of oil prices when formulating and implementing economic policies especially the exchange rate policies.

Methodology

This study employs the statistical tool of econometrics in analyzing quantitative (secondary) data generated from relevant agencies to study the relationship between oil price instability and manufacturing sector performance in Nigeria between 1980 and 2010. Appropriate econometric techniques were employed to conduct series of diagnostic tests on the variables. These include the unit root test (test for stationarity), test for co-integration and error correction mechanism (ECM), and causality test.

Model Specification

Based on the theoretical background that underlies this relationship, this study employed a regression model that aptly

captures the relationship between the variables. The model is specified as follows:

$$MOPR = F (OPR, EXR, INT,)..... (1)$$

The model is therefore split and linearized as:

$$MOPR = a_0 + a_1OPR + a_2EXR + a_3INTR + U_t (2)$$

where

MOPR = Manufacturing output growth rate

OPR = Oil price growth rate

EXR = Exchange Rate

INTR = Interest Rate

Ut = stochastic error term;

a_0 = Intercept of the regression line (a constant);

a_1 , a_2 , and a_3 are the partial coefficient of oil price growth rate, exchange rate, interest rate respectively.

Empirical Results and Discussions

This section presents and analyzes the results obtained after conducting the various tests for stationarity, co-integration, vector error correction estimates and causality. As a necessary but not sufficient condition for co-integration, each of the variables must be integrated of the same order, where the order of integration must be greater than zero. To achieve this, the study employed the unit root test for stationarity, using the Augmented Dickey-Fuller (ADF) approach.

Table 1: Unit Root Test for Stationarity

ADF TEST STATISTICS TEST		
Variables	ADF Test Statistic (constant included)	

		LEVEL	FIRST DIFFERENCE	Prob*
MOPR		-5.4530	-8.6750	0.0000
OPGR		-5.9382	-6.9645	0.0000
EXR		-0.2667	-4.7576	0.0007
INTR		-2.5916	-6.6218	0.0000
Test	1%	-3.6702	-3.6793	
Critical	5%	-2.9640	-2.9678	
Values	10%	-2.6210	-2.6230	

The result of the unit root test for stationarity of individual time series are reported in table 1 above. Data for MOPR and OPR were integrated at level, but EXR and INTR were not. However, all the time series were integrated of order one at 1, 5 and 10% levels of significance. The implication here is that the estimation of the parameters could not be carried out with the use of ordinary least square (OLS) regression. This may produce spurious coefficients, and thus, be misleading. In line with this, the Johansen approach was used to determine the number of co-integration vectors.

Table 2: Test for co-integration

Date: 12/09/14 Time: 20:28

Sample (adjusted): 1982 2010

Included observations: 29 after adjustments

Trend assumption: Linear deterministic trend (restricted)

Series: MOPR OPGR EXR INTR

Lags interval (in first differences): 1 to 1

Unrestricted Cointegration Rank Test (Trace)

Hypothesized		Trace	0.05	
No. of	Eigenvalue	Statistic	Critical	Prob.**
CE(s)			Value	
None *	0.713558	69.67575	63.87610	0.0150
At most 1	0.486804	33.41940	42.91525	0.3158
At most 2	0.278803	14.07356	25.87211	0.6515
At most 3	0.146536	4.595118	12.51798	0.6551

Trace test indicates 1 cointegrating eqn(s) at the 0.05 level

* denotes rejection of the hypothesis at the 0.05 level

**MacKinnon-Haug-Michelis (1999) p-values

Unrestricted Cointegration Rank Test (Maximum Eigenvalue)

Hypothesized		Max-Eigen	0.05		
No. of	Eigenvalue	Statistic	Critical	Value	Prob.**
CE(s)					
None *	0.713558	36.25635	32.11832	0.0147	
At most 1	0.486804	19.34585	25.82321	0.2826	
At most 2	0.278803	9.478441	19.38704	0.6745	
At most 3	0.146536	4.595118	12.51798	0.6551	

Max-eigenvalue test indicates 1 cointegrating eqn(s) at the 0.05 level

* denotes rejection of the hypothesis at the 0.05 level

**MacKinnon-Haug-Michelis (1999) p-values

Johansen co-integration test results contained in table 2 confirmed the existence co-integrating equations between or among the included variables in the model as indicated by the Trace-statistics and the Max-Eigen statistic. The Trace test indicates the existence of one (1) co-integrating equation at the 0.05 level of significance. This is indicated by the Trace- statistic values of 69.6758, which is greater than the critical value of 63.8761 at the 0.05 level of significance. This result is further confirmed by Mackinnon-Haug-Michelis (1999) p-values (i.e., Trace- statistic probability value) of 0.015, which are less than the 0.05 level of significance.

Max-Eigen statistic also confirmed the existence of one (1) co-integrating equation at the 0.05 level of significance. The Max-Eigen value of 36.2564 is greater than its critical value of 32.1183. This

result is further confirmed by the Mackinnon-Haug-Michelis (1999) p-value for Max-Eigen statistic probability value of 0.0147, which is less than the 0.05 level of significance.

Table: 3: Vector Error Correction Estimates

Vector Error Correction Estimates

Vector Error Correction Estimates

Date: 12/09/14 Time: 20:29

Sample (adjusted): 1982 2010

Included observations: 29 after adjustments

Standard errors in () & t-statistics in []

Cointegrating Eq: CointEq1

MOPR(-1) 1.000000

OPGR(-1) -0.539437

(0.08749)

[-
6.16555]

EXR(-1) 0.009094

(0.02784)

[0.32665]

INTR(-1) -0.347583

(0.32094)

[-
1.08302]

C 3.582922

Error Correction:	D(MOPR)	D(OPGR)	D(EXR)	D(INTR)
CointEq1	-0.619343 (0.23160)	2.044552 (0.50832)	0.167443 (0.27746)	0.063916 (0.06411)
	[- 2.67421]	[4.02215]	[0.60349]	[0.99695]
D(MOPR(-1))	-0.297947 (0.17923)	-1.485528 (0.39339)	-0.154222 (0.21472)	-0.102832 (0.04962)
	[- 1.66235]	[- 3.77626]	[- 0.71823]	[- 2.07258]
D(OPGR(-1))	-0.146000 (0.10000)	0.040611 (0.21949)	-0.016800 (0.11980)	-0.009412 (0.02768)
	[- 1.45997]	[0.18502]	[- 0.14023]	[- 0.34000]
D(EXR(-1))	0.010297 (0.18420)	1.070501 (0.40430)	0.147668 (0.22068)	0.011808 (0.05099)
	[0.05590]	[2.64779]	[0.66915]	[0.23156]
D(INTR(-1))	0.680429	0.027903	0.704478	-0.154142

(0.65714) (1.44232) (0.78727) (0.18191)

[1.03544][0.01935][0.89484] [-
0.84735]

C 0.032626 -3.262337 3.518124 0.224559
(2.38367) (5.23178) (2.85568) (0.65985)

[-
[0.01369] 0.62356] [1.23197][0.34032]

R-squared	0.486039	0.633472	0.089033	0.302125
Adj. R-squared	0.374308	0.553791	-0.109004	0.150414
Sum sq. resid	3145.092	15151.00	4514.002	241.0112
S.E. equation	11.69372	25.66591	14.00932	3.237090
F-statistic	4.350087	7.950186	0.449577	1.991442
Log likelihood	-109.1006	-131.8978	-114.3400	-71.85366
Akaike AIC	7.937973	9.510196	8.299314	5.369218
Schwarz SC	8.220861	9.793085	8.582203	5.652107
Mean dependent	0.686552	1.296897	4.402400	0.258621
S.D. dependent	14.78333	38.42269	13.30303	3.511971

Determinant resid
covariance (dof adj.) 1.11E+08

Determinant resid
covariance 43824093

Log likelihood -419.7344

Akaike information criterion 30.87824

Schwarz criterion 32.19838

The vector error correction results revealed the existence of long-run equilibrium relationship between or among the included variables in the model after correcting the error of the estimates. The co-integrating equation depicting the short-run dynamics is given as follows:

$$\text{MOPR} = 3.582 - 0.539\text{OPR} + 0.009\text{EXR} - 0.348\text{INTR} \dots\dots\dots$$

(1)

The equation revealed the impact of the various variables on manufacturing output in Nigeria during the period under study. The equation shows that EXR is positively related to manufacturing output, while growth in oil price and interest rate are inversely related to manufacturing output. Some of these findings are in violation of a priori expectations. The positive relation between EXR and MOPR is a deviation from theoretical expectations; the same goes for the negative relationship between oil price growth and manufacturing output. However, the negative relationship between INF and MOP is in tandem with a priori expectation.

The equation above reveals that a percentage increase in oil price pushed down MOP by 0.539 percent. However, a percentage increase in EXR pushed up MOP by 0.009 percent, while an increase in INTR by 1 percent resulted in a decrease in MOP by 0.348 percent.

However, when the vector error correction mechanism (VECM) was employed to tie the short-run dynamics of the co-integrating equations to their long-run static dispositions, the short-run dynamics of the relationship was absolved. Comparing the result of the short-run relationship, INTR was negative. But, introducing VECM, it became positive in the long-run. Moreover, introducing VECM revealed that the previous value of MOP (MOP_{t-1}) is inversely related to the present value of MOP (MOP_t). The speed of adjustment (ECM-1), which captures the rate at which the system, MOPR, adjusts to the equilibrium state after a shock, is 62 percent per year. As expected, this value bears a negative sign, an indication that the model is converging towards equilibrium. Thus, if MOP is above its equilibrium

value, it will start falling in the next period to correct the equilibrium error. By the same token, if MOP is below its equilibrium value, it will start to rise in the next period, and equilibrium will be restored.

Table 4: Granger Causality Test

Pairwise Granger Causality Tests

Date: 12/09/14 Time: 20:54

Sample: 1980 2010

Lags: 1

Null Hypothesis:	Obs	F-Statistic	Prob.
INTR does not Granger Cause EXR	30	0.0154 3	0.9021
EXR does not Granger Cause INTR	5	0.2093 5	0.6509
MOPR does not Granger Cause EXR	30	0.5252 0	0.4749

		5.9595	
EXR does not Granger Cause MOPR		9	0.0215
<hr/>			
OPGR does not Granger Cause		1.8930	
EXR	30	6	0.1802
<hr/>			
		5.8565	
EXR does not Granger Cause OPGR		9	0.0225
<hr/>			
MOPR does not Granger Cause		0.3124	
INTR	30	6	0.5808
<hr/>			
		0.0754	
INTR does not Granger Cause MOPR		5	0.7857
<hr/>			
OPGR does not Granger Cause		3.2043	
INTR	30	9	0.0847
<hr/>			
		0.0100	
INTR does not Granger Cause OPGR		3	0.9210
<hr/>			
OPGR does not Granger Cause		0.8428	
MOPR	30	8	0.3667
<hr/>			
		0.0247	
MOPR does not Granger Cause OPGR		3	0.8762
<hr/>			

The results on causality test showed that there is a unidirectional causality, where exchange rate granger causes changes in manufacturing output, but manufacturing output does not granger cause changes exchange rate. This is confirmed by the probability value of 0.0215, which is less than the 0.05 level of significance. The corresponding F-statistic of 5.9596 is also greater than the tabulated value of 3.35. The causality test also revealed a unidirectional causality, where exchange rate granger causes oil price change, but there is no feedback.

Test of Significance

T-test

This is the test of the significance of the individual parameter estimates. The system equation above reveals that the parameter estimates of all the explanatory variables, OPR, EXR and INTR were found to be statistically insignificant in the long-run. This is indicated by their probability values as revealed in the table above, which are all greater than 0.05 ($p > 0.05$), the chosen level of significance.

F-test

The F-test is a test to ascertain the joint influence of the explanatory variables on the dependent variable. The F-statistic is compared against the tabulated value under the corresponding degree of freedom (df), v_1, v_2 (3, 27). The F-statistic of 4.35, when compared with the corresponding tabulated value (3.35) shows that the joint influence of the included explanatory variables was statistically significant after correcting the error in the estimated equation.

Coefficient of Determination (R^2)

The value of R-squared (R^2) for the equation was 0.4860, indicating that the included exogenous variables, oil price, exchange rate and interest rate, accounted for about 48.60 percent of the change in the dependent variable, manufacturing output. The adjusted R-squared was 37.43 percent (0.3743). This implies that, after correcting the error in the estimated equation the goodness of fit of the model was low.

Test of Hypotheses

The following hypothesis was formulated and tested in the study:

Ho₁: There is no significant relationship between oil price instability and the manufacturing sector performance in Nigeria.

Decision:

Given the fact that the long-run parameter estimate for oil price (-0.015), as an individual variable, was statistically insignificant ($p > 0.05$) (even though negative), we do not reject the null hypothesis; we therefore, conclude that there is no significant relationship between oil price instability and the manufacturing sector performance in Nigeria.

Ho₂: Exchange rate volatility does not have adverse effect on manufacturing sector performance in Nigeria.

Decision:

The parameter estimate for exchange rate was positive (0.010), but statistically insignificant ($p > 0.05$). We, therefore, conclude that exchange rate volatility does not have significant adverse effect on manufacturing sector performance in Nigeria.

Ho₃: Interest rate does not have significant relationship with manufacturing sector performance in Nigeria.

Decision:

Interest rate, as expected, was negatively related to manufacturing sector performance (-0.680), but the parameter estimate was statistically insignificant ($p > 0.05$), which compelled this study not to reject the null hypothesis, but to conclude that interest rate does not have significant relationship with manufacturing sector performance in Nigeria.

However, the joint influence of the included explanatory variables on the dependent variable is measured by comparing the F_{critical} with $F_{\text{tabulated}}$. Since $F_{\text{crit}} > F_{\text{tab}}$ (i.e. $3.74 > 2.71$), we conclude that the explanatory variables have significant joint influence on manufacturing sector performance in Nigeria.

Conclusion and Recommendations

The study shows the importance of oil price fluctuations and instability in general to the growth of the manufacturing sector. The continuous rising and falling of oil price in the past few years is a pointer of low manufacturing output in Nigeria. This study came out with empirical evidence that will help in understanding the relationships among the variables used in the model drawing from the Nigerian experience. The study came to the realization that on their individual basis, manufacturing sector performance is not significantly related to oil price fluctuations, exchange rate volatility and interest rate; but are jointly related and influential. It was revealed that oil price, exchange rate and interest rate have the potentials of causing significant effects on manufacturing sector performance in Nigeria.

The following recommendations are put forward:

- (1)** There is the need for stability of oil price, exchange rate and interest rate in the economy. The importance of macroeconomic stability cannot be over emphasized if Nigeria's manufacturing sector performance is to be competitive in the international market. No matter what macroeconomic policy is pursued, if the rate of domestic inflation is higher than those of the trading partners in the international markets, the countries manufacturing output will lose competitiveness. It is only when relative prices are stable that there will be stable and consistent growth in the economy.
- (2)** Also, more policy attention should be given to regulation of exchange rate and a steady interest rate in Nigeria.

References

CBN (2002). Statistical Bulletin and Statement of Account

First Bank (1990). *Monthly Business and Economic Report*. Lagos, January.

Iwayemi, A. (2011), Oil and the Macroeconomic, A Perspective on Recent Economic Performance: A Case Study of Nigeria. An NCEMA Publication Ibadan.

Mandel, E. (1999). *The Sharp Shamp, A Marxist Analysis of Recession in the Seventies*. Berlin.

Nikbakht, L. (2009). Oil Prices and Exchange Rates: The Case of OPEC. *Business*

Intelligence Journal, 3(1), 83–92.

Ojapinwa, T. V. and Ejumedia, P. E. (2012). The Industrial Impact of Oil Price Shocks in

Nigeria: 1970-2010. *European Scientific Journal*, 8(12), 113-126.

Okigbo, P. N. (2009); *Nigerian Financial System, Structure and Growth*. London: Longman group.

Olashere, O. (2008). *Perspective of Finance, Banking and Economic Policy in Nigeria*. Ibadan: Heinemann Educational Books.

Olopoenia, B. A. (2013). Some Observations on the Macroeconomic Implications of the Budget on Oil Exploring Development Economy. *Nigeria Journal of Economics and Social Studies*. 28(3), November.

Oriavwote, V. E. and Eriemo, N. O. (2012). Oil Prices and the Real Exchange Rate in
Nigeria. *International Journal of Economics and Finance*, 4(6), 198-205.

Sibanda, K. and Mlambo, C. (2014). The Impact of Oil Prices on the Exchange Rate in
South Africa. *Journal of Economics*, 5(2), 193-199.

THE EFFECT OF HUMAN CAPITAL INVESTMENT ON CORPORATE PERFORMANCE: A CROSS SECTIONAL STUDY OF SELECTED QUOTED COMPANIES IN NIGERIA

BY
UZOAMAKA, ERNEST CHINYERUGO
*Department of Accountancy, Anambra State University,
Igbariam*

And

PROF. NWEZE, AUSTIN UCHECHUKWU, PhD
*Professor of Accountancy Enugu State University of
Technology, Enugu.*

ABSTRACT

The objective of the study was to examine the effect of investment in human capital and number of employees on: profitability, return on asset, and return on equity; Six research hypotheses were formulated for the study. Quantitative correlational design with population of 29 quoted companies in the health, ICT, and conglomerate sector of Nigeria Stock Exchange that have been neglected by researchers, out of which 8 were selected using Stratify random sampling techniques. Data collected from the Annual reports and accounts of the selected companies 2009 to 2013 were analysed using SPSS 20, Pearson Correlation in order to determine the confidence level for acceptance of hypotheses. The findings are that investment in human capital (measured by value added to employees) has positive effect on: profitability, return on assets and return on equity; while number of employees has negative relationship with profitability, return on assets and return on equity. Based on the findings, we recommended that organization should invest heavily on the human capital so as to ensure corporate performance of the organization. Nigerian organization should reduce the level of hire and fire and adopt the strategy of hire, train, retain and continuous investment on their human capital so as to achieve continuous growth and development. Rather than concentrating on quantity of employees, Nigerian

companies should concentrate more on quality of its human capital investment.

Key words: corporate performance; cross-sectional study; human capital investment; Nigeria

1. INTRODUCTION

Human capital is the quality and value of an organizations employees. Human capital is the sum of employee's congenital and acquired skills, knowledge and experiences of individuals (Kucharcikoval 2011). However Alika and Stan (2014) argues that commitment of individuals is the most significant aspect of human capital characteristics. They explained that no matter the knowledge, skills, and experience, etc. one may possess without commitment to perform, the employee may still not perform as expected unless there is the commitment to perform the given task creditably. Organization that lay no premium importance to its human capital investment is planning to collapse. Human capital is a critical force that derives economic growth, helps organizations to establish and maintain their competitive advantage and creates wealth (Abdel-Aziz, 2013).

Investment in human capital is the aggregate of expenditure on employee's skills, knowledge, experience, values, commitment, and education the employees possess. In financial term, investment in human capital can be said to be the monetary values an organization added or spend for its employees for his knowledge, skills, education and commitment. In economics, we have material, finance labour and machine as business capital, but the most valuable capital according to Rosak, Szyrocka and Borkowski (2007) is labour, which is the human capital. To them, workers are the most valuable resources of every organization, without regards to the range of executed tasks. The authors believed that human resources are the custodian of human capital innate to them and not transferable.

Investment in human capital is said to have positive relationship with organizational performance. There are many related studies on the

effect of investment in human capital on corporate performance. Most of these study establish positive effect of investment in human capital on corporate performance (see Vinish et al, 2010; Meng-Yuh, 2010; Recharad et al, 1999; Mahamoud et al, 2014; Simon-oke, 2012; Niringive, ND; Olalere and Adesoji, 2013; Alike and Stan, 2014; Angel, 2011; Dominique and Stiphanie, 2013; etc.). however the recent study of Nguyen et al (2013) revealed that investment in human capital currently does not have the considerable contribution to the improvement in performance of small and medium enterprises in Vietnam, therefore there is need to reinvestigate the effect of investment in human capital on corporate performance using Nigeria as a reference point.

In Nigeria, it is merely believed that the only thing that improve performance of human capital is the financial investment on individual workers, with the best of researchers knowledge, no such publicly available study has confirms it, hence this study investigates the effect of financial investment (aggregate investment measured in financial terms) in human capital on corporate performance in Nigeria in order to confirm such widely accepted view.

To the best of the researcher's knowledge, studies that have been carried out in Nigeria, are still scanty. The publicly available related studies in Nigeria are the works of Simon-Oke, (2012); Olalere and Adesoji (2013;) Adelowkan (2012); Ramat et al (2012); Okeude and Ogwude (2012); Satope (2012); Ehis and Olufemi (2013); and Sheriff et al (2012). Most of these studies were carried out at national level, also the studies that have been carried out at corporate level uses qualitative and survey design. The studies that uses quantitative design were carried out in the banking industry. Save the study of Olalere and Adesoji (2013) that was carried out in First Bank Plc, No other studies in Nigeria measures investment in human capital using accounting approach. There is all so no available literature on cross sectional study on the effect of investment in human capital on corporate performance in Nigeria.

However, the objective of this study is to cover up these gaps by investigating the effect of investment in human capital on corporate performance in a cross sectional study of selected quoted companies in

Nigeria, using quantitative design and accounting measurement approach.

Problem Statement

The high rate of unemployment in Nigeria has made corporate organizations not to place required importance to investment in human capital. They believe they can hire and fire with ease, hence to them investment in human capital does not matter. Nigerian firms neglect the literature that states that an employee cannot perform well or be motivated if he feels that his input to the organization does not equate the organization's input to him. Hence the need to examine if the number of employees has a significant impact on corporate performance.

The recent losses reported in the health sector in Nigeria, notwithstanding the increases in the expenditure on employees. Investment in human capital is increasing in the health sector of Nigerian companies without a considerable increase in performance. In 2012/2013 almost all the companies in the health sector reported before tax losses. Therefore there is a need to investigate whether the investment in human capital is compensated with the output of such investment.

Objectives of the study

For the purpose of the study, the specific objectives of the study are to investigate:

- I. The relationship between investment in human capital and profitability of quoted companies in Nigeria
- II. The effect of investment in human capital on return on assets of quoted companies in Nigeria
- III. The effect of investment in human capital on return on equity of quoted companies in Nigeria.
- IV. The relationship between the number of employees of an organization and profitability of quoted companies in Nigeria.

- V. The effect of number of employees of on return on assets of quoted companies in Nigeria
- VI. The effect of number of employees in human capital on return on equity of quoted companies in Nigeria

Statement of hypotheses

For the research, the following null hypotheses were put forward:

- I. There is no significant relationship between investment in human capital and profitability of quoted Nigerian companies.
- II. Investment in human capital has no significant effect on return on assets of quoted companies in Nigeria
- III. Investment in human capital does not significantly affects Return on equity of quoted companies in Nigeria
- IV. Number of employees of an organization is not related to profitability of quoted Nigerian companies.
- V. Number of employees has no significant effect on return on assets of quoted companies in Nigeria
- VI. Number of employees does not significantly affects Return on equity of quoted companies in Nigeria

Scope and limitations of the study

This study covers the effect of investment in human capital (measured using Value Added to employees) on: return on investment, profitability, and return on equity. Five years financial reports and accounts of eight selected companies from ICT, health and conglomerate of Nigerian quoted companies from 2009 to 2013 were used for the study.

The limitation of the study lies on the fact that the study focused on 3 sectors, Five years, and eight companies of all the quoted companies, which may not be good enough in the generalization of this study. Collection of data on detailed annual reports and account of quoted companies for before 2009 were very difficult, hence 5years were used. Annual reports of some years of the companies were based on National GAAP while some were based on FIRS. However these limitations were not significant enough to affect the finding of this study.

2. REVIEW OF RELATED LITERATURE

Many studies has being carried out on “investment on human capital and organizational performance” both in public and private sector, using different approaches and measurement of extent of investment in human capital. However for the purpose of the study, we limited our literature review on current literature especially those carried out in Nigeria.

Cheng et al (2010) studies the effects of intellectual capital on the health care industry, using an input-process-output concept of human, customer, innovative and process capitals, on company performances. From a resource-based and intellectual capital perspective, the structural path model is applied to financial data to analyse the six-value creation relationships among the four components of intellectual capital, as well as the causal effects of intellectual capital on company performance. Their empirical findings suggest a significant relationship between intellectual capital and company performance. These results also suggest that innovative capacity and process reformation shall be considered first, and through the human value-added of human capital, firms can improve their company's performance.

Ramat et al (2012) examines the impact of intellectual capital components on return on asset (ROA) in Nigerian Manufacturing companies. To this end, annual reports of sample companies were analysed using Value Added Intellectual Coefficient (VAICTM) as proposed by Pulic (2000). Human Capital Efficiency (HCE), Structural Capital Efficiency (SCE) and Capital Employed Efficiency (CEE) are used as intellectual capital components efficiencies, while ROA (productivity) was used as a measure of company's performance. The study further examines the impact of value added efficiency of IC on company performance with multiple regression techniques using SPSS 16 software package. The results show that, relationship exists between intellectual capital components efficiencies and company performance. Furthermore, human capital influences productivity (ROA) performance of the sample companies' more than structural and physical capital. Therefore, it is recommended that sampled companies should embark on policy that will improve their employees' skill such as training and development and good welfare package which ultimately will improve the overall performance of the companies

Simon-Oke (2012) study the relationship between human capital investment and industrial productivity in Nigeria using secondary data from through 1978 to 2008. Co-integration and Error Correction Mechanism (ECM) was employed to examine the nexus between human capital investment and industrial productivity. Granger causality test was also adopted as a supplementary estimation method to explore the nature of causality among the variables established in the model. The study found that government expenditure on education maintained a positive long run relationship with index of industrial production while government expenditure on health and Gross Capital Formation exhibited long run negative relationship with the dependent variable. Consequently they recommends among others that more stock of physical capital needed to be acquired, to facilitate more investment in human capital and thereby enhance industrial productivity in Nigeria

Okeudo and Ogwude (2012) Study establish a relationship between the human resource effects (i.e. the level of training and the academic qualification) and the productivity in the Nigerians transport industry stands. Primary data sources comprise of directed questionnaires that were administered to the parastatal and the transport firms of all modes of Transport (land, sea and air). Secondary data sources comprise of existing documents that have been published from various transport organisations. Data collected from the study were analysed using descriptive statistical methods like the frequency distribution, correlation technique and the frontier model. From the results of the analysis it was discovered that majority of the workers in the transport industry were unskilled with only a few workers possessing higher degrees, despite the positive relationship observed between the between human resource effect and the productivity. In conclusion it was seen that effects of productivity in transport firms in Nigeria depends largely on labour and capital inputs than on human resource effect.

Wurim (2012) critically assess the prospects of human capital planning in the achievement of organizational performance. A hypothesis in line with this objective is drawn and tested based on the data generated through a questionnaire. The survey investigation method was used in collecting the primary data for the study. The result shows that adherence to human capital planning significantly impact

organizational performance. It was concluded that human capital planning significantly accounts for improvements in organizational effectiveness in Nigerian public organizations. The study concludes that proper education and training in scientific human capital planning for HR manager and advocacy to influence the enactment of detrimental laws and legislations that have direct bearing on the human capital planning processes of their organizations

Sheriff, Ali, and Aliyu (2012) focused their study on the effect of human resource management on productivity of workers in Nigeria. It examines the role of training and development on workers' productivity in both public and private organizations in Nigeria. It also pointed out the problems of human resource management and personal manager. The paper concluded that human resource training and development is a long term and very sensitive function of an organization. They concludes proper implementation of training enhances individual performance and productivity.

Satope (2012) investigated the influence of human capital formation programmes of the government on job performance effectiveness in industrial organizations in Osun state. This is with a view to ascertain the importance of government service delivery programmes on industrial organizations in the State. The descriptive survey method was adopted for the study. Questionnaire was used to collect information from a total of 200 workers in manufacturing (Olaoluwa Aina Wire Industry) and agricultural industry (like those who went to Songhai). Oral interview was used to collect information from Ministries about the activities of the government. The results of the survey reveal that the human capital development programmes provided for workers have impacted on their job performance effectiveness. The computer training has significant effect on innovation, adaptability, staff development. Team building training programme also has significant effect on almost all the factors creativity, strategic leadership, teamwork; Interpersonal training programme has more significant effect on strategic leadership and teamwork, with more impact on teamwork. In addition, Communication skill training equally has significant effect on teamwork, innovation, satisfaction and finally, Labour-Management related Skill training impact more on creativity and strategic leadership and customer services. Based on their findings, they concludes that

capital formation programme should be allowed to go round all workers for equal development.

Nguyen et al (2013) investigates the determinants of human capital investment in the form of formal training (off-the-job training) and estimates effects of this investment on productivity using Propensity Score Matching (PSM) method. We use data from a survey of small and medium enterprises (SMEs) in Vietnam (completed in 2010) with detailed information about training and several firm characteristics. Our estimates reveal that investment in human capital currently does not have the considerable contribution to the improvement in productivity of SMEs. This result does not support the universalistic perspective in strategic human resource management (SHRM) theoretical model.

Olalere, and Adesoji (2013), examines the effectiveness of Human Capital Development Programmes of First Bank of Nigeria Plc. The study utilized both secondary and primary for gathering information. The primary source it uses both questionnaire and in-depth interview as instruments while secondary data uses the organization's human capital development chart, handbook and training records. The findings revealed that the Human Capital Development Programmes of First Bank of Nigeria Plc have improved the skills, attitude and performance of staff of the bank which invariably has led to the achievement of organizational goals and objectives. Their findings also discovered the need for the bank to put in place motivational policies that will be attractive to the staff in order to retain them after the training and development exercise.

Ehis and Olufemi (2013) determines the effectiveness of strategic management of human capital development on employee's performance in Nigeria cement sector. Emphases were made on the relative roles of strategic management of human capital development in the Nigerian cement sector. Their study discuss number of factors that contributes to the success of Nigerian cement sector; these factors are skills, experiences, qualification of individual employees, ideas etc. They further examine whether that strategic management has helped the development of employees performance in the Nigerian cement sector. They divided the cement sector into zones e.g. Lagos, Ibadan, and Ekiti. This resulted to total population of 750 employees in

the cement industry as at the time the research was conducted. The Taro Yamae statistical formula was used to determine the sample size of 511. The researcher made use of primary and secondary source of data collection for the findings. They founds that constant training and development of employees has helped the cement sector to do well in their business operation which will help improved quality and innovation with the goal of gaining complete advantage through human resource. That the contribution of HCD can lead to organizational performance and effectively linked to changes in different business environment including micro and macro context

Abdel-Aziz, (2013), investigate the influence of Human Capital on Jordanian Pharmaceutical Organizations' Business Performance. He collects Practical data from 132 out of 200 managers, by means of a questionnaire. Statistical techniques utilized in the study were descriptive statistics, t-test, ANOVA test, correlation, multiple regressions, stepwise regression, sequential regression, PLS were employed. To confirm the suitability of collected data, a Kolmogorov-Smirnov test, and Cronbach's Alpha and factor analysis were used. The findings indicated: 1) A positive significant relationship between HC and JPOs' BP, 2) Respondents believe that "learning & education" and "innovation & creation" variables positively and directly affect the JPOs' BP, while the "experience & expertise" variable does not. 3) HC can clearly explain productivity and profitability more than market valuation.

From the literature reviewed, it is evidenced that studies carried out in Nigeria are still scanty, most of these study establish positive effect of investment in human capital on corporate performance. however the recent study of Nguyen et al (2013) revealed that investment in human capital currently does not have the considerable contribution to the improvement in performance of small and medium enterprises in Vietnam. In Nigeria, it is merely believed that the only thing that improve performance of human capital is the financial investment on individual workers, with the best of researchers knowledge, no such publicly available study has confirms it, hence this study investigates the effect of financial investment (aggregate investment measured in financial terms) in human capital on corporate performance in Nigeria in order to confirm such widely accepted view. Most of Nigerian studies were carried out at national level, also the studies that have been

carried out at corporate level uses qualitative and survey design. The studies that uses qualitative design were carried out in the banking industry. Save the study of Olalere and Adesoji (2013) that was carried out in First Bank Plc, No other studies in Nigeria measures investment in human capital using accounting approach. There is all so no available literature on cross sectional study on the effect of investment in human capital on corporate performance in Nigeria.

3. DESIGN AND METHODOLOGY

Study design

For the purpose of the study, quantitative and relational design was adopted in other to determine the objective view of the effect of investment in human capital and corporate performance of the selected companies.

Population and sampling

The population of this study is all the Nigeria quoted companies, however, the population is limited to three sector that has been neglected by researchers. The population of the three sectors are ICT 13 companies, Health 10 companies and conglomerate 6 companies.

Stratify random sampling techniques were used to select a total of 8 companies from the 29 population.

Sources of data

Secondary sources of data were used for this study. Sources of the data include: journals annual reports and accounts of selected firms, internet publications and magazine were utilized for the study. However the main sources of data used for the analyses and evaluation of hypotheses is the 5 years detailed annual reports and accounts of the selected 8 companies.

Method of data analyses

SPSS 20, Product Moment Pearson Correlation was used to analyse secondary data collected from the sampled population. This statistical tool determines the significant level in which null hypotheses will be based for acceptance or otherwise of the sample population.

Note that the researcher allowed 5% level of significance.

4. DATA PRESENTATION AND ANALYSES

Data Presentation

The data were presented in a table and were categorized accordingly. The data presented here were extracted from Appendix I, where the preliminary computation were explicated.

Table 1 financial data of selected companies

Year	2009	2010	2011	2012	2013
Number of employees	7656	7666	7228	6355	6423
Value added to employees	9137074	10615974	12055373	13386650	1522220
Net income/profit	10671085	11011182	15217880	20372555	2444430
Interest	2634360	3992882	3728345	6126703	6951490
Total assets	159871107	179377182	195927459	236073884	2500990
Equity	87679868	89329618	93568739	122151296	1425340
Return on assets	12.39008	12.0568	13.92008	14.30027	15.860
Return on equity	12.17051	12.32646	16.26385	16.67813	17.149

Source: Researchers' computation 2015 from Annual reports and accounts of the selected companies (see Appendix I).

NB:

$$\text{Return on Assets} = \frac{(\text{Net income} + \text{interest}) \times 100}{\text{Total Assets}}$$

$$\text{Return on Assets} = \frac{\text{Net income} \times 100}{\text{Total Assets}}$$

$$\text{Return on Equity} = \frac{\text{Total Equity}}{\text{Total Equity}}$$

The table 4.1 above shows the total number of employees, Value Added to employees (investment in human capital), net income/profit, interest, total assets, total equity, return on assets, and return on equity for the period 2009 to 2013 from the selected companies.

Analyses of Data/Testing Of Hypotheses

Decision rule

We reject the null hypothesis if the significance level generated by SPSS (P) is less than the level of significance we allowed for the test ($\alpha = .05$) otherwise accept null hypothesis.

Reject H_0 if $P \leq \alpha$ i.e. if $P \leq .05$. Otherwise accept H_0

Note:

- the researcher allowed 5% significant level
- Where the test is a one tailed test, the significance generated by SPSS is divided by two in order to convert the test to a 1tailed test.

Hypotheses Results.

Table 2: hypotheses 1-3 Correlations

		Investment in Human capital	Return on assets	Return on Equity	Profitability
Investment in Human capital	Pearson Correlation	1	.949*	.910*	.974**
	Sig. (2-tailed)		.014	.032	.005
	N	5	5	5	5
Return on assets	Pearson Correlation	.949*	1	.927*	.971**
	Sig. (2-tailed)	.014		.024	.006
	N	5	5	5	5
Return on Equity	Pearson Correlation	.910*	.927*	1	.900*
	Sig. (2-tailed)	.032	.024		.037
	N	5	5	5	5

Profitability	Pearson Correlation	.974**	.971**	.900*	1
	Sig. (2-tailed)	.005	.006	.037	
	N	5	5	5	5

*. Correlation is significant at the 0.05 level (2-tailed).

**. Correlation is significant at the 0.01 level (2-tailed).

Source researchers computation 2015 using SPSS 20

Table 3: hypotheses 4-6 analyses Correlations

		Number of employees	Return on assets	Return on Equity	Profitability
Number of employees	Pearson Correlation	1	-.893*	-.893*	-.960**
	Sig. (2-tailed)		.041	.041	.009
	N	5	5	5	5
Return assets	Pearson Correlation	-.893*	1	.927*	.971**
	Sig. (2-tailed)	.041		.024	.006
	N	5	5	5	5
Return Equity	Pearson Correlation	-.893*	.927*	1	.900*
	Sig. (2-tailed)	.041	.024		.037
	N	5	5	5	5
Profitability	Pearson Correlation	-.960**	.971**	.900*	1
	Sig. (2-tailed)	.009	.006	.037	
	N	5	5	5	5

*. Correlation is significant at the 0.05 level (2-tailed).

**. Correlation is significant at the 0.01 level (2-tailed).

Source researchers computation 2015 using SPSS 20

Hypothesis One.

From the analyses of data (shown in table 2) it was discovered that $r = 0.974$ and the significance level calculated (P) is less than the significance level allowed for the test. That is $0.005 < .05$, we therefore reject null hypothesis and accept the alternate hypothesis and concludes that:

“There is a positive significant relationship between investment in human capital and profitability of quoted Nigerian companies”

Hypothesis Two.

From the analyses of data (shown in table 2) it was discovered that $r = 0.949$ and the significance level calculated (P) is less than the significance level allowed for the test. That is $0.014 < .05$, we therefore reject null hypothesis and accept the alternate hypothesis and concludes that:

Investment in human capital has significant positive effect on return on assets of quoted companies in Nigeria.

Hypothesis Three.

From the analyses of data (shown in table 2) it was discovered that $r = 0.910$ and the significance level calculated (P) is less than the significance level allowed for the test. That is $0.032 < .05$, we therefore reject null hypothesis and accept the alternate hypothesis and concludes that:

Investment in human capital significantly affects Return on equity of quoted companies in Nigeria positively.

Hypothesis four.

From the analyses of data (shown in table 3) it was discovered that $r = -0.960$ and the significance level calculated (P) is less than the significance level allowed for the test. That is $0.009 < .05$, we therefore reject null hypothesis and accept the alternate hypothesis and concludes that:

Number of employees of an organization is negatively related to profitability of quoted Nigerian companies.

Hypothesis five.

From the analyses of data (shown in table 3) it was discovered that $r = -0.893$ and the significance level calculated (P) is less than the significance level allowed for the test. That is $0.041 < .05$, we

therefore reject null hypothesis and accept the alternate hypothesis and concludes that:

Number of employees has a negative significant effect on return on assets of quoted companies in Nigeria

Hypothesis six.

From the analyses of data (shown in table 3) it was discovered that $r = -0.893$ and the significance level calculated (P) is less than the significance level allowed for the test. That is $0.041 < .05$, we therefore reject null hypothesis and accept the alternate hypothesis and concludes that:

Number of employees significantly affects Return on equity of quoted companies in Nigeria negatively.

5. SUMMARY OF FINDINGS CONCLUSION AND RECOMMENDATIONS

Summary of Findings

The following findings were made:

- I. There is a positive significant relationship between investment in human capital and profitability of quoted Nigerian companies"
- II. Investment in human capital has significant positive effect on return assets of quoted companies in Nigeria.
- III. Investment in human capital significantly affects Return on equity of quoted companies in Nigeria positively.
- IV. Number of employees of an organization is negatively related to profitability of quoted Nigerian companies.
- V. Number of employees has a negative significant effect on return on assets of quoted companies in Nigeria
- VI. Number of employees significantly affects Return on equity of quoted companies in Nigeria negatively.

Conclusion

Based on the findings we concludes that investment in human capital positively affects: profitability; return on Assets; and return on equity

of quoted companies in Nigeria. These our findings are consistent with prior studies save the study of Nguyen et al (2013) that provide insignificant effect of human capital investment on performance. Our findings has also confirms the generally accepted view that investment in human capital measured in terms of finance motivates Nigerian employees, hence this study is consistent with the view.

Number of employees of an organization have negative effects on: profitability; return on assets; and return on equity. Having higher number of employees without considerable financial investment on them does not guarantee corporate performance, rather such higher number of employees will diminish corporate performance growth of the organization. These finding confirms that human being can no longer be said to be a machine but should be treated with adequate care and investment so as to ensure productivity and performance growth of the organization.

Recommendations

Based on the findings, we recommends that organization should invest heavily on the human capital so as to ensure corporate performance of the organization. Nigerian organization should reduce the level of hire and fire and adopt the strategy of hire, train, retain and continues investment on their human capital so as to achieve continues growth and development. Nigerian quoted companies should place more importance to its human capital than physical capital since, human capital are custodian of other capital and can determine when to perform. Therefore investment for employee's skill, education, experience, and commitment should be an invaluable investment of quoted companies in Nigeria. Rather than concentrating on quantity of employees, Nigerian companies should concentrate more on quality of its human capital investment.

REFERENCES

Abdel-Aziz A. S. (2013), the Relationship between Human Capital and Jordanian Pharmaceutical Organizations' Business Performance. International Journal of Academic Research in Business and Social Sciences, 3(1), 260 - 279

- Adelowokan, O. A.,(2012), Growth effect of Education and Health Expenditure in Nigeria (1970-2010). *African Journal of Scientific Research*, 10(1), 510-529
- Alika, I. J, and Stan A (2014) Human capital: definitions, approaches and management dynamics. *Journal of Business Administration and Education*, 5(1), 55-78.
- Angel F., (2011), Human capital and productivity. *Barcelona Economics Working Paper Series*, 1(530), 1- 22
- Cheng M., Lin J., Hsiao T., and Lin T. W. (2010) Invested resource, competitive intellectual capital, and corporate performance. *Journal of Intellectual Capital*. 11(4), 433-450
- Dominique R. and Stephanie S., (2013) Intellectual Capital Impact on Investment Recommendations: Evidence from Indonesia. *European Journal of Business and Management*, 5(12), 100-110
- Ehis O. and Olufemi A. (2013), Strategic Management of Human Capital Development on Employees Performance in Nigeria cements Sector. *Lead City Equity Research*, 1(1), 1-19
- Kucharcikova (2011) Human Capital – Definition and Approaches. *Journal of Human Resources Management and Ergonomics*, 5(1), [http://:www.frcatel.fri.uiza.sk/hrme/files/2011/2011_205.pdf](http://www.frcatel.fri.uiza.sk/hrme/files/2011/2011_205.pdf)
- Mahmoud B., Homa M., Maliheh K., and Mahboubeh R (2014), Study of the Effect of Intellectual Capital Components and Firm Size. *Kuwait Chapter of Arabian Journal of Business and Management Review*, 3(11), 212-220
- Nguyen K. D. (2013), Investment in Human Capital and Labour Productivity in Southern Key Economic Zone: an Application of Propensity Score Matching Method. *Journal of Economic Development (JED)* 1(215), 61-86
- Niringiye A., (ND), Effect of human capital labour productivity in Sub Sahara African manufacturing firms. *Globelics conference, Malasia*.

- Ogujiuba K. (2013), The impact of human capital formation on economic growth in Nigeria. *J Economics*, 4(2): 121-132.
- Okeudo G. N., And Ogwude I. C., (2012), Relationship between human resource effects and productivity in the Nigerian Transport Industry. *British Journal of Science*, 6(1), 67-80
- Okpala, P. O and Chidi, O. C., (2010), Human capital accounting and its relevance to stock investment decisions in Nigeria. *European Journal of Economics, Finance and Administrative Sciences*, 1(21), 64-77. <http://www.eurojournals.com>
- Olalere, T. O. and Adesoji A. A., (2013), Human capital development in First Bank of Nigeria PLC. *Mediterranean Journal of Social Sciences*, 4(2), 783-801
- Ramat T. S., Muzainah M., Adebola D. B., and Mahamad T (2012), Impact of intellectual capital on return on asset in Nigerian manufacturing companies. *Interdisciplinary Journal of Research in Business*, 2(4), 21- 30
- Richard B., Lorraine D, Costas M., and Barbara S. (1999) Human capital investment: the returns from education and training to the individual, the firm and the economy. *Fiscal Studies*, 20(1), 1–23.
- Rosak-Szurocka-Boriowski, S. (2007) Workers as the Basic Determinant of the Stationery Medical Treatment Services Quality, *in Proceedings of 4th International Scientific Conference Manazment Tudskeho Potencialu v Podniku Zilina*,
- Satope B. F. (2012), Influence of Human Capital Formation Programme On Job Performance Effectiveness In Selected Industrial Organizations In Osun State, Nigeria. *Journal of Social Science and Public Policy* 4(Dec), 30-41.
- Sheriff B, Ali B. S., and Aliyu I. (2012), The Effect of Human Resource Management on Productivity of Workers in Nigeria. *Journal of Business and Organizational Development* 4(Jun). 54-59

Simon-Oke O. O. (2012), Human Capital Investment and Industrial Productivity in Nigeria. *International Journal of Humanities and Social Science*, 2(16), 298-307

Vinish K., Rajesh R. S. N., and Kunal S. (2010), Human capital and manufacturing productivity growth in India. *Vancouver, 8th International Industrial Organization conference*.

Wurim, B. P. (2012), Uman Capital Planning and Organizational Performance in the Nigeria Public Sector. *Journal of Research in Arts & Social Sciences*, 1(1), 1-11.

APPENDIX I

NUMBER OF EMPLOYEES

year	computer warehouse	Charms	HIS	CBS	Fidson	Glaxos mithkline	AG Leventis
2009	388	296	532	43	283	361	1169
2010	444	239	816	52	284	353	1328
2011	557	180	894	55	326	332	1482
2012	574	122	1056	65	319	372	1578
2013	612	75	1231	67	331	436	1474

VALUE ADDED TO EMPLOYEES

year	computer warehouse	Charms	HIS	CBS	Fidson	Glaxos mithkline	AG Leventis
2009	612344	450086	307495	28044	450906	1220289	1402710
2010	977472	686635	420983	37144	612365	1433423	1748543
2011	1068446	513190	1144026	46960	998894	1556216	2179041
2012	1475999	373087	1459301	58634	622343	2069771	1790515
2013	1342600	437657	1843236	64444	679488	2283942	2071840

NET INCOME/PROFIT

year	computer warehouse	Charms	HIS	CBS	Fidson	Glaxos mithkline	AG Leventis
2009	554130	- 2474699	1047718	215935	623036	2469596	158918
2010	356480	- 1801323	675353	231237	642183	2935285	878446
2011	238960	- 1198400	-1839383	303635	214264	3492620	1022423
2012	444064	169627	2886917	377629	540080	4171665	1037183
2013	632099	106923	3499983	403030	249591	4314829	1227392

INTEREST

year	computer warehouse	Charms	HIS	CBS	Fidson	Glaxos mithkline	AG Leventis
2009	274999	70866	451162	10888	191208	1500	185937
2010	128823	275588	1397851	9232	207646	696	109293
2011	146176	226240	1174770	11164	353729	1787	164062
2012	641046	230133	1994284	33767	317548	151	377774
2013	348778	216472	2508658	4263	407697	514	470114

TOTAL ASSETS

year	computer	Charms	HIS	CBS	Fidson	Glaxos	AG
------	----------	--------	-----	-----	--------	--------	----

	warehouse					mithkline	Leventis
2009	3076144	7702413	23511569	2483406	5267324	12078362	11660651
2010	3745777	5177551	26274175	2646638	5350817	14253912	19555876
2011	3280851	4037031	25562129	2686271	7617413	17940156	21103307
2012	4285701	4700271	47889846	3436576	8208393	21792721	22784783
2013	5342262	4677747	56015938	3360099	8981000	26213663	20493625

EQUITY

year	computer warehouse	charms	HIS	CBS	Fidson	Glaxos mithkline	AG Leventis
2009	1596144	7192543	9492527	2447970	5095021	6583242	10308685
2010	1788732	5151734	10578448	2627527	5230914	7846408	10518185
2011	1884315	4011215	8459938	2656413	5190377	8982428	10647236
2012	3298486	4489583	25226625	2817545	5228436	10663060	9826303
2013	5275047	4677747	30471324	2965395	5245335	12345714	10234031

Source: Reports and accounts of the selected companies 2009 to 2013

Year	2009	2010	2011	2012	2013
Number of employees	7656	7666	7228	6355	6423
Value added to employees	9137074	10615974	12055373	13386650	15222207
Net income/profit	10671085	11011182	15217880	20372555	24444364
Interest	2634360	3992882	3728345	6126703	6951496
Total assets	159871107	179377182	195927459	236073884	250099828
Equity	87679868	89329618	93568739	122151296	142534412
Return on assets	12.39008	12.0568	13.92008	14.30027	15.8603
Return on equity	12.17051	12.32646	16.26385	16.67813	17.1498

Source: Researchers' computation 2015.

NB:

$$\text{Return on Assets} = \frac{(\text{Net income} + \text{interest}) \times 100}{\text{Total Assets}}$$

$$\text{Return on Equity} = \frac{\text{Net income} \times 100}{\text{Total Equity}}$$

MANAGEMENT ACCOUNTING

SIGNIFINANCE OF HUMAN CAPITAL TO ORGANISATIONAL VALUE CREATION.

Dr. M.O. Adelowotan & Mr. O. Olaoluniyi
Department of Accounting & Finance
Distance Learning Institute
University of Lagos.
Akoka, Lagos.
Email: oolaoluniyi@unilag.edu.ng
Tel: +2348023418528

ABSTRACT

Introduction

Human capital (HC) has been recognised as one of the three major categories of intangible resources capable of creating value for business organisations. The present economy referred to as the new economy is characterised largely by knowledge which consequently makes human capital to remain as an important intangible resource necessary for achieving competitive advantage and sustainable organisational success and growth.

Objective of the study

This paper explains the significance of human capital in the light of three concepts namely, the human capital theory; the human capital advantage and the human capital management.

Research methodology

The study employed the qualitative method of literature review to discuss and show the significance of human capital to organisational value creation.

Major findings

The discovery of value-creating potential of human capital will arouse greater interest in human capital strategic management practices. It will also necessitate the provision of more information in the Corporate Annual Reports (CARs). Most significantly, the CARs will be more decision-useful.

Keywords: Human capital, value, competitive advantage, human capital theory, human capital advantage and human capital management.

Paper Type: Conceptual paper

Introduction

The term “capital” has been described as an institutional system which facilitates the progressive development of technology and organisational structures, the differentiation and legitimisation of organisational processes to enhance capital accumulation and development (Clegg & Dunkerley 1980:5 in Abeysekera 2008:16). Human capital (HC) has also been portrayed as a significant component of intangible assets (IAS) which constitutes a major driver in the value creation process in the new economy of knowledge-intensive companies (Abhayawansa & Abeysekera 2008:51). In today's new economy, intangible knowledge and intelligence that emanate from human capital are critical inputs in the value creating process (Hai-Ming & Ku-Jan 2003:470). Therefore, it could be said that the dawn of the new economy has prompted the shift of companies' value drivers from physical tangible assets to non-physical intangible assets.

Purpose of the study

The purpose of this paper is to provide an explanation for the significance of human capital by analysing the conceptualisation of human capital in the literature through the human capital theory; the human advantage and human capital management approaches. These explanations will make it possible to address the dilemma of the low level of emphasis placed on human capital disclosures despite the regular assertion in the corporate annual reports that employees are the companies' greatest asset.

Methodology

The paper commences with the review of literature on human capital as an important component of intangible assets. It then conceptualise the relationship between human capital and value creation. Then an explanation for significance of human capital was made in the light of human capital theory, human capital advantage and human capital management.

Review of literature on human capital

The literature portrayed Intellectual Capital (IC) as encompassing three interrelated components identified as Human Capital (HC); Structural Capital (SC) and Relational Capital (HC). (Cabrilo; Nestic & Mitrovic, 2014, Bontis, 1998, Stewart, 1997)

The term "human capital" was coined by the economist Schultz (1961). He discovered that the yield on human capital investment through education and training in the United States was larger than that based on investment in physical capital. Bontis, Dragonetti, Jacobsen and Ross (1999:391-402) defined HC as representing the human factor in the organisation, the combined intelligence, skills and expertise that give the organisation its distinctive character. These human characteristics of the organisation are those that enable people to be capable of learning, changing, innovating and providing the creative thrust, which if properly motivated, can ensure the long-term survival of the organisation. Social accounting theorists believe that the valuation and incorporation of human capital should be viewed as part of the total assets base reflected in a firm's statement of financial position (Stittle 2004:313).

HC as distinct from economic capital is also referred to as the combination of factors owned by individual employees and the collective workforce of an organisation (Abeysekera 2008:16). Hence, HC is made up of the intellectual skills and capabilities, knowledge obtained through education and training which consequently allow an individual to execute given tasks more effectively and productively. It is generally recognised as an intangible resource capable of creating value for organisations (Meritum 2002:63).

Human capital also includes personal traits such as intelligence; energy; attitude; reliability; commitment; ability to learn, aptitude; imagination; creativity; desire to share information, participate in a team, and focus on the goals of the firm (Fitz-enz 2000 in Abeysekera 2008:16).

Several researchers conclude that human capital is important because it creates capital accumulation when carefully extracted and developed (O'Donnell, Tracey, Henricken, Bontis, Cleary, Kennedy, & O'Reagan 2006:112; Graham & Pizzo 1998; Edvinsson & Sullivan 1996:361). This shows that organisations may use HC disclosure programmes to enhance capital accumulation (Tinker 1985:14–15 in Abeysekera 2008:18). The importance of human capital is portrayed by the competition in the human capital market for the acquisition and

retention of highly skilled labour with commensurable monetary and non-monetary rewards, although it is not certain whether these rewards reflect the perspectives of both the users and providers of human capital intangibles.

Sveiby (1997:10) pioneered the tripartite framework of IA and conceptualises HC as employee competence which include explicit knowledge, skill, experience, value judgement and social network. There seems to be a consensus in the IA literature in conceptualising HC as a combination of attributes like knowledge, skill, abilities and personality characteristics which are portrayed by individuals and corporately. (Abeysekera & Guthrie 2004:253). In portraying the importance of HC, Becker (1964) explains that HC is the foundation for the wealth-creating capacity of an organisation.

HC has been described as the source of innovation and strategic renewal regardless of where it originates, whether it originates from arranging files and other clerical works to brainstorming, re-engineering and problem-solving. The used and the useful knowledge of an employee is the source of human capital resources. Apparently, the common assertion that people are the most important resource is both right and true (Adelowotan, 2013).

The concept of HC has formed the basis of many theoretical and empirical studies in the management sciences. A recent study examined the relationship between human capital (HC) and value creation and employee reward. The study conceptualise HC by linking its value with adequate pay, increasing motivation, commitment and productivity. (Massingham & Tam, 2015). HC has been considered as the most significant value driver in the new economy characterised by knowledge (Adelowotan, 2013).

Human capital and value creation

Between the late 1960s and early 1970s, many academics conducted research on the contribution of human capital to the growth of firms, but between the late 1970s and early 1990s, there seems to be a sharp decline in this research area. However, the dawn of the 21st century witnessed a fresh awakening to this area of research. Major evidence that attest to this is the interest shown by the Institute of Chartered Accountants for England and Wales (ICAEW) through their declaration that HC "... is the coming competitive advantage in the modern knowledge economy, and measuring and reporting human

capital is essential to building sustainable economic success" (ICAEW 2000).

Some researchers have conducted studies which led to the understanding that an individual's education and training have significant role to play in organizational performance (Becker, 1983; Mincer, 1974). In most cases, the remuneration of employees is strongly tied to the quantity and quality of employees' education and experience (Fisher & Govindarajan, 1992; Harris & Helfat, 1997). Human capital performance has been found to be strongly influenced by individual and corporate investments in education and training (Combs, Liu, Hall, & Ketchen, 2006). Human capital has also been referred to as a combination of knowledge, skills and abilities embodied in people (Coff, 2002). These major human capital attributes of knowledge, skills and abilities when combined with employees experiences through education and training have been viewed as the main drivers of standardized performance (Hambrick & Mason, 1984 in Cook, Combs, Todd, Woehr & Ketchen 2011:444).

Some studies were conducted in order to explore the relationship between human capital and value creation. For instance, Edvinsson and Sullivan (1996:358) argue that it is the ability of an organisation to pull knowledge and not necessarily the stock of knowledge that will drive value creation. Organisations that give serious consideration to the capability, knowledge, skills of human resources will attain value creation capacity (Wright & Snell 2005:178). Low (2000) argues that HC is a top non-financial performance driver. This is supported by Skoog who suggests that there exists a positive correlation between disclosed HC and the long run profitability of a firm (Skoog 2003:487). The position of Low and Skoog is further strengthened by the arguments of Mouritsen, Bukh, & Marr (2004:53) that firms could gain the advantage of attracting valuable resources in addition to communicating the organisation's value drivers through full disclosure of HC information. Human capital is an asset that can provide a source of sustained competitive advantage because they are often difficult to imitate (Popova & Sharpanskykh 2010).

A clear cut policy on the management, measurement and disclosure of HC will ensure transparency and consequently increase the degree of confidence that the investors and other stakeholders have in the organisation (Olsson 2001). This means that a progressive firm will

convert HC capabilities to meet the increasing expectations of stakeholders (Bassi, Lev, Low, McMurrer & Siesfeld 2000; Van der Meer-Kooistra & Zijlstra 2001:456).

The conclusions of other researchers also suggest that many organisations have realised that HC practices and their disclosures play a significant role in the performance of firms (Boudreau 1991; Wright & McMahan 1992:303). This has resulted in a great shift by management towards the contribution of human resources in the last decade (Bassi et al 2000). Firms who engage in pragmatic HC practices such as acquisition, development and retention of employees, incentive compensation, employee empowerment, selective staffing, job rotation, comprehensive training and team work can intensify the value creation processes (Youndt, Snell, Dean, & Lepak 1996:839).

Human Capital Theory

Human capital was regarded as inputs from physical strength by the traditional classical economists. This suggests that there is little or no need for skills because, according to them, a standardized capability inherent in all labour exists. Also, William Petty (1674), a classical economist, used the concept of human capital to compare losses in soldiers, weapons and other instruments of war. This idea remained unchallenged until an American economist-T.W. Schultz put forward the concept of human capital for the first time in 1961. He proposed that human capital includes abilities, knowledge, skills and qualifications possessed by individuals. Later in 1981, Adam Smith argued that human capital investment and employee skills affect individual earnings and pay structure and regarded employees' skills as a significant source of economic growth as well as economic and social welfare.

Some early researchers defined and explained human capital in the context of a human capital theory which states that an economic value is generated through an individual's skills, experience and knowledge. This idea supports Sveiby's explanation of employee competence as the stock of knowledge resident in employees. Pena (2002:182) examines three indicators namely the entrepreneur's level of education, experience and motivation to connote human capital from the definition of HC as the accumulation of personal traits in the form of knowledge, abilities, personality that enable employees to perform. Mincer (1989) refers to HC as the stock of knowledge capable of

generating growth through innovation as well as the stock of skills provided through education and training.

Other researchers explain HC in terms of employee's skills only (Flamholtz & Lacey 1981) and in terms of the combination of knowledge, skills and abilities of people. Mackelvery (1983) and Hudson (1993) define human capital on an individual level as the combination of an individual's generic inheritance; education; experience and attitude towards life and business. The common factor in these definitions is that employee's attributes are capable of creating values.

The human capital theory is at the centre of many economic theories which seek to provide explanations for the connection between individuals' skills, productivity and earnings (Pantzalis & Park 2009:1610). This theory has been associated with the resource-based view of the firm by Barney (1991:102) who makes a proposition that sustainable competitive advantage is attained when the firm has a human resource pool that cannot be imitated or substituted by its rivals. The theory postulates that an individual's skills, experience and knowledge generate economic value to an organisation and that he can be stirred-up through education and training by individual employees.

Human capital theory portrays employees as embodying a set of skills which can be 'let to' employers. The knowledge and skills an employee has arising from regular education and training as well as the training that experience brings produce a certain stock of productive capital (Ehrenberg & Smith 1997 in Andrei & Iacob 2011). The application of HC theory to skills of the employees continued in the works of Flamholtz and Lacey 1981. The interpretation of the theory was explained with certain human capital attributes such as knowledge, skills and abilities of employees (Mackelvery 1983). Also, basing his argument on the theory, another researcher portrays HC as a stock of skills produced by education and training and also a stock of knowledge which generates growth through innovation (Mincer 1989).

In a study which employs a qualitative research design as well as a limited analysis of respondents' demand for Durban University of Technology (DUT) programmes aimed at examining the strength of relationship between individuals' enrolment intentions and their expected returns from investments in the institution's educational programmes. The study further considers whether human capital

theory suggests an explanation for students' demand for higher education (Van der Merwe, 2010:82). The finding from this study confirms the proposition of human capital theory that students consider higher education as an investment (Van der Merwe, 2010:81).

Human capital advantage

In support of the value creation attribute, the concept of human capital advantage was developed to show the significance of human capital believed to be the source of sustainable competitive advantage for firms with a pool of employees that cannot be copied or substituted by its competitors (Boxall 1996:8). This is also in line with the resource-based view of the firm which also emphasises retention, motivation and development of high-quality employees and provides a competitive advantage in the form of human capital. The resource-based view of the firm points to sources of human resources as an advantage in exceptional human capital and outstanding human process (Boxall 1996:12). The use of HC reporting was motivated by the need for management control as concluded by Grojer and Johanson (1998:496). Also, Stewart (1994) was of the opinion that IC reports were published (most especially by Scandinavian companies) as a means of reflecting IC value and as a way of managing these value drivers.

HC is an important element of IA driven value creation in the new economy, particularly in knowledge intensive companies. Despite the importance of impact of HC on the performance or market value of a firm, there are limited empirical studies on the impact of HC on the performance or market value of a firm. Among the few studies which are focussed on the impact of HC on the value of a firm are Pena (2002:190) who found out there was a positive relation between the entrepreneur's level of education, experience and motivation and the performance of a new venture. The departure of a company's CEO was found to be associated with negative market reactions (Diedman & Lin 2002:81). Successful business strategies were also discovered to be associated with personal traits of the top executive officers (Ashton 2005:53). Investment analysts make use of corporate annual reports as a justification for making investment recommendations and forecasting earnings.

Human capital management

In order to further emphasise the significance of HC, the concept of human capital management (HCM) was developed. HCM is concerned with obtaining, analysing and reporting data that informs the direction of value adding, strategic, investment and operational people management decisions at corporate level and at the level of frontline management. HCM has also been defined as an integrated effort to manage and develop human capabilities to achieve significantly higher levels of performance (Chatzkel 2004). This view is supported by Kearns (2005) because he suggests that HCM is about creating value through people. Human resources, on the other hand, is an asset that can provide a source of sustained competitive advantage because they are often difficult to imitate (Popova & Sharpanskykh, 2010).

The Accounting for People Task Force Report (2003) refers to HCM as a process involving the systematic analysis, measurement and evaluation of how people policies and practices create value. HCM suggests that an organisation's success is the product of its employee's competence and therefore the causal link between people and performance should be made visible and available to all stakeholders. HCM seeks to treat employees as assets which need to be measured, managed and reported on while human resources management (HRM) seeks to treat employees as significant costs that should be managed in that regard (Mayo 2001, Kearns 2005).

In the new economy, human capital is at the centre of value creation because knowledge-based organisations are emerging as a direct consequence of increasing forces of globalisation and technological advancement. These types of organisations recognise human capital as the dominant wealth creator and driver. This is contrary to what operated in the old economy when firms spent huge sums of money on machines and so remained bundles of tangible assets whose ownership remain with the investors who employ people for their operations.

Organisations in the new economy now spend an increasing portion of their capital on human capital intangibles and equipment needed for gathering, processing, analysing and distributing information. The new economy organisations (knowledge organisations) have intangible assets as their assets whose ownership cannot be easily determined. In these organisations, human capital is arguably the most important driving factor while financial risk capital is the major factor distinguishing them from the new economy organisations (Rudolf 2004: 48).

Professor Dave Ulrich of the University of Michigan Business School notes that organisations are now aware that their competitive advantage lies in their employees and not in their machines or products and that hiring the right people with adequate support systems will cause them to be conquerors in the battle in the competition arena (Ulrich, 1998). This can be ascribed to the fact that competitors may copy the product, strategy and technology, but it is difficult to copy another firm's human capital. Leiv Edvinsson metaphorically refers to intellectual capital as a tree and the people as the sap that makes organisations grow (Stewart, 1997:86). Money talks, but does not think, machines perform but cannot invent (Cascio, 1998). Knowledge workers through their bodies, minds and souls both think and invent (Stewart 1998).

Findings and conclusion

The conceptualisation of the value creating potential of human capital through multiple approaches will necessitate greater interest and action on the part of the preparers of corporate annual reports in providing more information on human capital intangibles and also arouse the interest of management in developing better human capital strategic management practices. The combined effect of these two affirmative actions will lead to making corporate annual reports more decision-useful and at the same time contributing to increase in corporate values.

This paper attempts to conceptualise human capital value creation potential by explaining this in the light of multiple theories or approaches namely the human capital theory, human capital advantage and the human capital management. In the new economy characterised by knowledge-intensive organisations, investors need better information as an explanation for the intangible value of human capital. This can be achieved through strategic human resource management (HRM) practices and systematically collected and analysed data on human capital and, more importantly, through both internal and external communication of this data.

Acknowledgements

The authors acknowledge the doctoral grant provided by the Institute of Chartered Accountants of Nigeria as well as the contributions of participants at the 1st ICAN Academic Conference on Accounting and Finance.

REFERENCES

1. Abeysekera, I & Guthrie, J. (2004). Human capital reporting in a developing nation, *British Accounting Review*. 36 (3):251–268.
2. Abeysekera, I. (2008). Motivations behind human capital disclosure in annual reports. *Accounting Forum* 32:16–29.
3. Abhayawansa, S & Abeysekera, I. (2008). An explanation of human capital disclosure from resource-based perspective. *Journal of Human Resource Costing and Accounting*. 12(1):51–64.
4. Adelowotan, M.O. (2013). Human capital disclosures in Corporate Annual Reports. Doctoral Thesis.
5. Accounting for People Task Force. (2003). *Accounting for people*. London: DTI.
6. Andrei, A & Iacob A.G. (2011). *Human capital and organizational performance*. Managerial challenges of the contemporary society 3:130-136.
7. Ashton, R.H. (2005). Intellectual capital and value creation: a review. *Journal of Accounting Literature* 24:53.
8. Barney, J. (1991). Firm resources and sustained competitive advantage. *Journal of Management*, 17, March: 99–120.
9. Bassi, L.J, Lev, B, Low, J, McMurrer, D.P & Siesfeld, G.A. (2000). Measuring corporate investment in human capital: the new relationship. Washington, DC: Human Capital in the American Corporation, Brookings Institution.
10. Becker, G. (1964). *Human capital: a theoretical and empirical analysis, with special reference to education*. New York, NY: National Bureau of Economic Research.
11. Becker, G. S. (1983). *Human capital: A theoretical and empirical analysis with special reference to education*. Chicago, IL: University of Chicago Press.
12. Bontis, N, Dragonett, WC, Jacobsen, K & Roos, G. (1999). The knowledge toolbox: a review of the tools available to measure and manage intangible resource. *European Management Journal* 17(4):391–402.
13. Bontis, N. (1998). Intellectual capital: an exploratory study that

develops measures and models. *Management Decision* Vol. 36 No 2; 63 – 76.

14. Boudreau, JW. (1991). Utility analysis in *Human Resource Management Decisions*. Vol 2. Palo Alto, CA: Consulting Psychologists Press.
15. Boxall, P. (1996). The Strategic HRM debate and the resource-based view of the firm, *Human Resource Management Journal* 6(3):59–75.
16. Cascio, W.F. (1998). The future world of work: implications for human resource costing and accounting. *Journal of Human Resource Costing and Accounting*. 3(2): 9-19.
17. Cabrilo, S; Nestic, L.G; & Mitrovic, S. (2014). Study on human capital gap for effective innovation strategies in the knowledge era. *Journal of Intellectual Capital*. Vol. 15(3): 411 – 429.
18. Chatzkel, J.L. (2004). Human capital: the rules of engagement are changing. *Lifelong Learning in Europe* 9(3):139–145.
19. Coff, R. W. (2002). Human capital, shared expertise, and the likelihood of impasse on corporate acquisitions. *Journal of Management*, 28, 107– 128.
20. Combs, J., Liu, Y., Hall, A., & Ketchen, D. (2006). How much do high-performance work practices matter? A meta-analysis of their effects on organizational performance. *Personnel Psychology*, 59, 501– 502.
21. Diedman, E & Lin, SWJ. (2002). Shareholder wealth effects of CEO departures: evidence from the UK. *Journal of Corporate Finance* 8:81–104.
22. Edvinsson, L & Sullivan, P. (1996). Developing a model for managing intellectual capital. *European Management Journal* 14(4):356–364.
23. Fisher, J., & Govindarajan, V. (1992). Profit center manager compensation: An examination of market, political and human capital factors. *Strategic Management Journal*, 13, 205–217.
24. Flamholtz, E.G & Lacey, J.M. (1981). *Personnel Management Human Capital: Theory and Human Resources Accounting*. Los Angeles, CA: Institute of Industrial Relations, University of California

25. Graham, A.B. & Pizzo, V.G. (1998). A question of balance: case studies in strategic knowledge management, in *The strategic management of intellectual capital*, edited by DA Klein. Woburn, MA: Butterworth-Heinemann.
26. Grojer, J.E & Johanson, U. (1998). Current development in human resource costing and accounting reality present, researchers absent?" *Accounting, Auditing and Accountability Journal* 11 (4):495–505.
27. Harris, D., & Helfat, C. (1997). Specificity of CEO human capital and compensation. *Strategic Management Journal*, 18, 895–920.
28. Hudson, W. (1993). *Intellectual capital: how to build it, enhance it, use it*. New York, NY: Wiley.
29. Institute of Chartered Accountants in England and Wales (ICAEW). 2000. *Human capital and corporate reputation: setting the boardroom agenda*. London: Institute of Chartered Accountants in England and Wales, available at: www.icaew.com/index.cfm/route/121246/icaew-ga/pdf
30. Kearns, P. (2005). *Human capital management*. Sutton, Surrey: Reed Business Information.
31. Low, J. (2000). The value creation index. *Journal of Intellectual Capital* 1(3):252-262.
32. Mackelvey, B. (1983). *Organisation as systematic: taxonomy, evolution, and classification*. Berkeley, CA: University of California Press.
33. Mayo, A. (2001). *The human value of the enterprise valuing people as assets*. London: Nicholas Brealey.
34. Measuring intangibles to understand and improve innovation management (Meritum). 2002. Target Socio-Economic Research, Brussels: European Commission.
35. Mincer, J. (1989). *Labour market effects and its adjustment to technological change* New York, NY: Institute of Education and the Economy, Columbia University.
36. Mincer, J. (1974). *Schooling, experience, and earnings*. New York, NY: Columbia University Press.
37. Mouritsen, J, Bukh, P.N & Marr, B. (2004) Reporting on intellectual capital: why, what and how? *Measuring Business Excellence* 8

- (1):46–54.
38. O'Donnell, D, Tracey, M, Henricken, LB, Bontis, N, Cleary, P, Kennedy,T & O'Reagan, P. (2006). On the 'essential condition of intellectual capital: labour!' *Journal of Intellectual Capital* 7(1):111–128.
 39. Olsson, B. (2001). Annual reporting practices: information about human resources in corporate annual reports in major Swedish companies, *Journal of Human Resources and Accounting* 6 (1):39–52.
 40. Pantzalis, C & Park, JC. (2009). Equity market valuation of human capital and stock returns. *Journal of Banking and Finance* 33:1610–1623.
 41. Pena (2002). Intellectual capital and business start-up success. *Journal of Intellectual Capital*, Vol. 3 No 2, :180–98.
 42. Petty, W. (1960), *Political Arithmetic*, Shanghai: The Commercial Press.
 43. Rudolf, W. (2004). *Human capital as the centre of all business in building human capital: a South African perspective*, edited by I Boninell & TWA Meyer. Johannesburg: Knowres Publishing.
 44. Schultz, T.W. (1961), "Investment in Human Capital," *The American Economic Review*, 51(5): 1035–1039.
 45. Skoog, M. (2003). Visualising value creation through the management control of intangibles *Journal of Intellectual Capital* 4 (4):487–504.
 46. Smith, A. (1981), *An Inquiry into the Nature and Causes of the Wealth of Nations*, Shanghai: The Commercial Press.
 47. Stewart, TA. (1997). *Intellectual capital*. London: Nicholas Brealey.
 48. Stewart, TA. (1998). *Intellectual capital – the new wealth of organisations*. London: Nicolas Brealey.
 49. Stittle, J. (2004). UK corporate reporting of human capital: a regulatory failure to evolve. *Business and Society Review* 109(3):311–337.
 50. Sveiby, K.E. (1997). *The new organisational wealth: managing and measuring knowledge based assets*. San Francisco, LA:

- Berrett-Koehler.
51. Tinker, A.M. (1985). *Paper prophets*. New York: Holt, Rinehart, and Winston.
 52. Ulrich, D. (1998). A new mandate for human resources. *Harvard Business Review*. January-February: 124-134.
 53. Van der Merwe, A. (2010). *Does human capital theory account for individual higher education choice?* *International Business & Economics Research Journal* 9(6):81-93.
 54. Van der Meer-Kooistra J & Zijlstra S.M. (2001). Reporting on intellectual capital. *Accounting, Auditing and Accountability Journal* 14(4): 456–476.
 55. Wright, P.M & McMahan, G.C. (1992). Theoretical perspectives of strategic human resource management. *Journal of Management* 18 (2):295–320.
 56. Wright, P.M Snell, S.A. (2005). Partner or guardian? HR's challenge in balancing value and values. *Human Resource Management* 44 (2):177–182.
 57. Youndt, M.A, Snell, S.A, Dean, L.W & Lepak, C. (1996). Human resource management, manufacturing strategy and firm performance. *Academy of Management Journal* 39 (4):836–66.

attainment of cost advantage and enhancement of performance. The main objective of this study is to investigate the extent of implementation of ABC by manufacturing firms in Kwara state and examine its impact on performance of firms using this technique. A cross-sectional survey design was employed for the study and questionnaire administration used in data collection. Twenty –eight (28) manufacturing firms in Kwara state formed the sample of the study. The data collected were analyzed using both descriptive statistics and regression analysis. Specifically, the Ordinary Least Square (OLS) was used in testing the hypotheses formulated. The findings of this study show that ABC is moderately implemented by the manufacturing firms in Kwara state as only 35% of the sampled firms indicated they are implementing this technique. The testing of hypotheses shows that activity-based costing implementation has a positive impact on accurate cost information, cost advantage and firm performance.. The study concludes that when accountants are well trained and the firm has improved technology ABC can be effectively implemented and will have a positive impact on its performance. The study recommends that manufacturing firms that are yet to start the implementation of ABC should do so as it can improve their performance where the right environment exist; accounting professional bodies should improve on the depth of their Mandatory Continuous Professional Education (MCPE) programme to include training on the implementation of modern costing technique such as ABC system; and future research on the examination of the impact of ABC implementation on firm performance in the service industry should be carried out.

Key Words: *Activity - based costing, Accurate cost information, performance, Accountant competency and Technology growth*

1 INTRODUCTION

Business environment worldwide has changed over the years as competition among firms is the order of the day. This has also affected the manufacturing of products to the extent that production activities have become more mechanized and sophisticated due to improvement in technology. Some of the improvements in manufacturing activities include manufacturing automation, computer aided manufacturing, the use of robots for production and application of just- in- time production systems.

The improvement in manufacturing processes arising from technological advancement has led to a change in production cost structure of manufacturing firms. Before the advancement in production technology the cost structure of manufacturing firms was dominated by material and direct labour costs but this has changed as overhead costs now form a major part of manufacturing costs (Blocher, Chen and Lin, 1999). Overhead costs has to increase due to the use of more machines leading to increase in depreciation cost, engineering cost, power cost, and data processing cost, etc.

The increase in overhead costs coupled with firms having diverse product lines and more complex products demand for more sophisticated costing technique to generate accurate and credible cost information for effective decision making. The traditional absorption costing which allocates overheads using just one cost driver or at most two cost drivers can no longer produce the desired results. The traditional costing system was developed when production was more labour intensive and production overhead costs were minimal. The allocation of overhead costs needs to be focused on as it will determine the accuracy of cost information and profitability of a firm. The traditional absorption costing could no longer cope with the increase in manufacturing activities and overhead costs. This necessitated a new costing system (activity –based costing) that will provide solutions to cost allocation problem with the use of multiple cost drivers.

In today's global competition, firms cannot afford the risk of making decisions based on inaccurate cost information from the traditional absorption costing system. The need to obtain accurate information for the enhancement of firm's performance cannot be satisfactorily met under the traditional costing system. In order for manufacturing firms to make decisions that are right, and which could lead to cost

advantage and performance enhancement, accurate and undistorted cost information is required.

The traditional absorption costing system is not able to produce accurate cost information due to the following reasons:

Firstly, it uses only one cost driver or at most two cost drivers which are also volume based, typically direct labour hours or machine hours to allocate overhead costs (Johnson, 1990). Secondly, the absorption costing system distorts product cost information because firms now produce heterogeneous and complex products which make it difficult for the system to determine the 'true cost' of the product (Akinleye and Adigbole, 2010). Lastly, the increase in overhead costs over the years has further made it difficult for the traditional costing system to produce accurate cost information as direct material and direct labour costs no longer form the major components of a product cost (Ahamad, 2012 as cited in Imeokparia, 2013).

The inability to determine the 'true cost' cost of products by firms can affect the proper and accurate pricing of their products especially where pricing is based on cost (Hopper and Major, 2007). Without accurate product pricing there is tendency for the firm to either loose revenue or loose customers' patronage due to over pricing of products. These problems provide the framework for this study.

Arising from the research problem, the main research question in this study is: What is the current state of the practices of activity-based costing and the impact on firm's performance in the selected manufacturing firms?

The broad objective of this study is to determine the level of adoption of activity-based costing and assess the impact on firm's performance in the sampled manufacturing firms.

Arising from this broad objectives of study the following hypotheses stated in null term are tested in this study

H₀₁: Activity-based costing implementation dimensions do not significantly influence accurate cost information.

H₀₂: Accountant competency and technology growth do not significantly influence the implementation of activity-based costing.

H₀₃: Activity-based costing implementation does not have a significant impact on firms' performance.

The scope of this study covered the examination of the impact of activity – based costing implementation on the performance of selected manufacturing firms in Kwara State, Nigeria. The data collected were cross sectional data from the sampled manufacturing firms as at 2015

2 LITERATURE REVIEW

Conceptual Framework

Definition of Activity- based costing and its Emergence

Activity –based costing has been defined and described by various authors; and few will be examined here. According to Hopper and Major (2007) activity-based costing is a method of measuring the cost and performance of activities and cost objects. It assigns cost to activities based on their use of resources and assigns cost- to cost objects based on their use of activities. Jarvenpaa (2007) describes activity- based costing as a system which provides management with a valuable new tool to assist in determining and allocating product cost more realistically. It also provides the means by which to isolate and account for costs in relation to activities associated with these costs.

Activity –based costing was introduced by Cooper and Kaplan in the late 1980s (Cooper and Kaplan, 1988a). During this period, the limitations of the traditional costing system was becoming obvious as it was designed for manufacturing companies many decades ago when there were few products, direct material and labour cost were dominant parts of factory costs (Drury 2004).

Activity based costing was developed in order to overcome the problems of the traditional costing system (Turney, 1996; Cooper and Kaplan 1998). These limitations are: traditional absorption costing uses a single cost driver which is such as direct labour hour rate or machine hour rates in allocating overheads to products or services which is inadequate as overheads cannot accurately be traced to the cost objects (Maelah and Ibrahim, 2006). It assumes that products or services are the real consumers of resources instead of activities (Blocher, *et al*, 1999; and Hansen and Mowen, 2000); which is not the

case. It uses a volume related cost driver such as plant wide or departmental rates in the second stage of the two - stage allocation process; using volume related bases for cost assignment does not reflect the true cause and effect relationship between overheads and cost objects; and it will lead to the distortion of product cost information it also fails to provide information that can be applied to cost management and performance improvement (Cooper and Kaplan, 1998).

Objectives and Modality for Implementation of Activity - Based Costing

Activity- based costing system is meant to achieve certain objectives such as: to provide accurate product cost information for product costing, setting of selling price, and determining marketing channels (Turney, 1996; Blocher et al, 1999); to provide relevant cost information for strategic cost management purposes since the system starts with the identification of activities which consume resources; to provide accurate information on costs of activities in order to manage processes and activities, continually increase efficiency of business operations and enhancement of performance (Cooper & Kaplan, 1999); and lastly, to provide information for management in formulating and implementing business strategies.

The key idea in the implementation of activity-based costing system is that activities consume resources and products consume activities. This system also uses a two - stage allocation process but in contrast to the traditional costing system it first relates the firm's resources to activities performed by these resources and then linked the cost of these activities to cost objects such as products or services (Sakurai, 1996).

Activity – based costing is implemented through a two - stage allocation process. Drury (2004) summarized the whole steps involved in activity–based costing system into four main stages examined below:

The first stage in activity –based costing is determining the activities required to be performed to produce a product. Activities are made-up of a combination of work or tasks and are described by verbs associated with tasks (Cooper & Kaplan, 1998).

The second stage is to identify costs of activities and then assign them to these activities. The classified costs according to activities are called activity cost pool (Garison & Noreen, 2000). Overhead costs can be collected from the accounting records of the organization and then assigned to activity cost pool according to the actual usage of resources by activities (Hasen & Mowen, 2000).

The third stage involves the selection of appropriate cost drivers for the assignment of activity cost to products or services (cost objects). A cost driver is a characteristic of an activity or event that results in the incurrence of costs by that activity or events (Hilton, 2002). In order to assign the costs attached to each activity cost centre to product or service a cost driver has to be selected for each activity centre (Drury, 2004; Cooper & Kaplan, 1998).

The fourth stage which is the final stage in the implementation of the activity- based costing system entails linking the activity costs to the cost objects (products, services and consumers) which are the ultimate consumers of activities using appropriate cost drivers. Drury (2004) suggest that cost drivers to be used must be measurable in a way that enables it to be identified with individual products.

The Concept of Firm Performance

Performance is the output or result of an organization measured in financial or non financial, or quantitative or non quantitative terms. Performance is one type of effectiveness indicator.

In relating performance to organization, Yamin Gunasekruan and Mavondo (1999) describe organizational performance as the extent to which an organization achieves its market oriented and financial goals. They noted that a broader conceptualization of business performance is to emphasize on indicators of operational performance (i.e. non financial) in addition to indicators of financial performance. Hassan, Shaukat, Naivaz, and Naz, (2013) examined organizational performance by classifying them into financial performance, innovative performance, marketing performance and production performance.

Singh, Sandhu, Metri and Kaur (2010) observed that in performance measurement in any organization, focus should be on these two factors; those that relate to results and those which relates to the determinants of the result.

The Impact of activity based costing on Performance

The role of activity –based costing in enhancing performance in an organization was for a long time not supported with empirical evidence (Innes and Mitchell, 1990; Mc Gowan, 1998). However, today it has been proved empirically that activity based costing has a positive impact on firm’s performance either directly or indirectly. Ebben and Johnson (2005); Reed and Sclar (2005) provide evidences that reducing unnecessary costs can improve a company’s performance. The firm offering high quality products from production process efficiency which activity –based costing facilitates, can charge premium prices and increase profit margin on sales and returns on investments (Rattanaphaphtham & Ussahawanitchakit 2010). Besides, it has been noted by Camal, Acar and Tanriverdi (2006) that increase in competitive advantages due to cost advantages derivable from activity –based costing encourages firms to achieve high financial performance. Activity–based costing also facilitates the enhancement of customer’s value which can lead to customer’s satisfaction and increase in patronage that translates to increase in sales and profits.

2.2 Theoretical Framework

This study used the blending of the resource based view and the contingency theory to explain the impact of activity –based costing on performance of selected manufacturing firms. These theories are examined as follows:

Resources – Based View

Teeche, Pinsno and Shuen (1991) posits that the basis of resources-base view theory is that successful firms will find their future competitiveness on the development of distinctive and unique capabilities which may be tangible or intangible in nature.

According to Barney (1991), the resource – based view define firm resources as all assets capabilities, organizational processes, firm attributes, and information knowledge controlled by a firm. It proposes that a firm has a competitive advantage when it creates a successful strategy based on its resource that cannot be duplicated by a current or potential competitor. The theory further states that the resources and capability must be rare, valuable, non– imitable, non substitutable and not transferable. Tontiset and Ussahawanitchakit (2009) noted that the bundles of resources are heterogeneously distributed across firms, and that the resource differences persist over time According to Grant (2001) resources are inputs into the production process; they are the basic units of analysis; the individual resources of the firms include items of capital equipment, skills of individual employees, patents, brand name, finance e.t.c. In identifying the resources of the firm, Grant (2001) further provide the six major categories of resources of the firm as; financial resources, physical resources, human resources, technological resources, reputation and organizational resources.

The resources –based view emphasizes that firm’s resources are the most important determinants of competitive advantage and performance. The resource – based view variable used in this study to explain the relationship between activity – based costing implementation and performance is accountant competency.

This study therefore proposes accountant competency as resource and capability to create and sustain competitive advantage that can enhance firm performance.

Contingency Theory

The contingency theory of management accounting refers to the premise that there is no universally appropriate accounting system equally applicable to all organizations in all circumstances (Oly, 1980 & 1994); instead, accounting systems are shaped by environmental (Harrison, 1992; Abbadi, 2013) and organizational (Chenhall and Morris, 1986) factors. These factors are considered to be contingent factors. What the contingent theorists argue is that management accounting systems are functions of certain contingent factors. Therefore, management accountants can follow this mantra and then design a suitable accounting system instead of believing in one best system which is available everywhere for everybody (Wickramasinghe and Alawattage, 2007). Contingency theory suggests that the need for efficient organizational structures, processes and competent management accounting system is contingent on organizational and environment characteristics. These variables influence changes in the structure and sophistication of cost management system or advance cost accounting techniques (Cogwin and Bouwinman, 2002; Drury and Tayles, 2005). The theory focuses on contingent factors associated with a business circumstances and their relationships with organizational systems and effectiveness. Chenhall (2003) classified contingency factors that have a major effect on management accounting practices into five main elements as: environment, technology, organizational size, structure, strategy and national culture. In the light of the discussion so far, this study indicates that the following contingency factors: top management support, technology growth, and competitive volatility will influence the activity –based costing system to achieve organizational performance.

2.3 Review of Empirical studies

Kennedy and Affleck –Graves (2001) studied the impact of activity –based costing technique on firm performance using a sample of 47 UK firms adopting activity –based costing and another sample of 183 firms

that had not adopted activity –based costing. Mailed survey questionnaires were used in collecting data for the study. The study also showed that firms adopting activity –based costing were 27% better than firms not using activity –based costing in terms of performance.

Itner, Lanen and Larcker (2002) studied the association between activity-based costing (ABC) and manufacturing performance in United States. The study was conducted using data from 1997 PriceWater House Coopers and industry week annual census of manufacturers in US. It was a survey of US manufacturing companies using a cross sectional sample of manufacturing plants. The findings indicate that extensive use of ABC is associated with higher quality levels and greater improvements in cycle time and quality (types of performance measure) and is indirectly associated with manufacturing cost reduction due to quality and time improvements.

In carrying out a study of activity- based costing, Rattaphaphthan and Ussahawanitchakit (2010) investigated the influence of activity- based costing (ABC) effectiveness on competitive advantage and performance of 521 selected Thai listed firms. The study used the resources based view and contingency theory to study the variables involved. The questionnaire mailing method of data collection was employed to collect data from the sampled firms. The ordinary least square (OLS) regression analysis was used to test the hypothesized relationships among the variables examined after the factor loading of the variables was carried out (Aulakh, Kotab and Teegen (2000)). The results of the study show that ABC effectiveness is significantly and positively related to financial performance. This study only focuses on a financial performance without including non- financial performance as part of the dependent variable. This current study fills this gap by examining both financial and non financial measures of performance.

Another study of the effect of activity –based costing on firm performance was carried out by Fei and Isa (2011) by examining a

sample of 1000 listed Chinese manufacturing firms. The study investigated the role of activity –based costing in predicting the improvements in firms performance. The results of the study show that on overall the successful implementation of activity –based costing could results in the improvement in manufacturing and business performance.

Finally, using a cross sectional survey of manufacturing companies in Nigeria, Imeokparia (2013) examined the adoption of activity - based costing and its impact on manufacturing company's profit in 262 manufacturing firms in the South West of Nigeria. Data were collected through the instrument of questionnaires administered to the sampled manufacturing companies. The regression analysis was used in testing the hypotheses formulated in the study. The results of the study indicate that manufacturing companies that have adopted activity - based costing had increase in their profitability measured by return on capital employed (ROCE) and other measures. This study did not show whether or not activity –based costing can improve manufacturing firms performance indirectly through the mediating variables like: accurate cost information and cost advantage. The study also did not used resource based view factor of accountant competency as theoretical background.

This current study fills the observed gaps on the literature reviewed. An attempt was made to replicate a similar study especially that of Rattaphaphthan and Ussahawanitchakit, (2010) with modifications in the Nigeria environment. This study fills the observed gap by examining whether or not activity –based costing can impact on manufacturing firms performance directly. This study also integrates two theoretical perspectives of resource based view and contingency theory to support the antecedents variables(technology growth and accountant competency) and consequences of activity –based costing implementation (accurate cost information). This is rare in the study of activity –based costing in Nigeria.

3 METHODOLOGY

Sample

This study relied on survey design as it deemed more appropriate compared with other designs of research to achieve the objectives of the study. The population of this study covered all manufacturing firms registered with the Manufacturers Association of Nigeria (MAN), Kwara State branch and as at 2015, there were 48 manufacturing firm. However, only 30 manufacturing firms were still operating as at the time of this survey, hence this figure was used in determining the sample size. The sample size of this study calculated scientifically using the Yaro Yamani formular ($n = \frac{N}{1 + N(e)^2}$) (Okorie cited in Imeokparia, 2013) is 28 manufacturing firms. The purposeful and convenient sampling method was then used in selecting the firms that form part of the sample.

Questionnaire and Procedure for data collection

The questionnaire was designed in such a way that all the data required for the variables used in the study were properly captured. The questionnaire was structured into seven sections as follows: Section 1: Demographic data of the respondents; Section 2: Firms characteristics; Section 3: Questions on adoption of ABC; Section 4: Question on the use of cost driver analysis for ABC implementation and the cost allocation effectiveness in the firm; Section 5: Consequences of ABC implementation – Accurate cost information and Firm performance; Section 6: Questions on Technology growth and Accountant competency in the firm (Contingency theory and Resource – based view factors) that affects the implementation of ABC in the firm.

For the purpose of data collection a total of 84 copies of the questionnaire were distributed to the target respondents - Financial accountants, Cost accountants/ Management accountants and Chief accountants/ Finance directors across the 28 sampled manufacturing firms. This translates to three (3) copies of the questionnaire per firm.

The target officers of the firm were chosen because they are experts in cost and management accounting techniques and so could give answers to questions on activity – based costing implementation. Out of the 84copies of questionnaire administered only 56 copies could be retrieved despite four visits made to the sampled firms. Of the copies received, 2 copies were not properly completed leaving 54 completed and usable copies of the questionnaire. In overall, this translates to 64.3% success rate in collection of copies of questionnaire distributed.

Variables Measurement

Dependent variable: Firm performance

Firm performance is measured in this study using a six items (performance indicators) of : profit, return on investment (ROI), cost reduction, sales volume and customer satisfaction adopted from Aksoylu (2013). Firm performance was assessed by the respondents in two ways as follows: Firstly, the firm was assessed on changes in the five items of firm performance indicators as a result of the implementation of activity – based costing using a five-point Likert scale; and second, to assess the performance of their firms in comparison with the competitors also using the five items of firm performance indicators using a five-point Likert scale.

Independent Variables : Cost driver analysis and cost allocation effectiveness

These variables are measured using a five –point Likert scale.These were adopted from Wagner (2006) and Rattanaphaphtham and Ussahawanitchakit (2010) with some modifications.

Consequence Variable: Accurate cost information

The consequence variable in this study is accurate cost information. This can also be regarded as non financial performance measure in a way. This variable was measured using a five – point Likert scale.

Antecedent Variables : Accountant competency and Technology growth.

These variables are measured using a five –point Likert scale and adopted from Chanopas, Krain and Khang, (2006); Rattanaphaphthan and Ussahawanitchakit, 2010; Prasad, Ramamurthy and Naidu, (2001) (as cited in Chikanbang *et al* (2012); Kaneko *et al*, 2013.

Validity and Reliability

The reliability test was carried out and the result of the cronbach's alpha statistics for all variables vary from 0.923 to 0.986. These results are valid and are very high which imply an acceptable internal consistency among the variables in the instrument of data collection (Devellis, 1991).

Methods of Data Analysis and Model Specification

The data collected were analyzed using regression analysis. Specifically, the Ordinary least square (OLS) analysis was used in testing the hypotheses formulated in this study. This technique was adopted from similar study such as Rattanaphaphthan and Ussahawanitchakit (2010).

The model formulated to explain the hypothesized relationships in this study and to achieve the three objectives (2 to 4) are given below:

$$\text{Equation. 1a: } CDA = \beta_0 + \beta_1 ACOM + \beta_2 TEGG + \varepsilon$$

$$b: CAE = \beta_0 + \beta_3 ACOM + \beta_4 TEGG + \varepsilon.$$

$$2: ACI = \beta_0 + \beta_5 CDA + \beta_6 CAE + \varepsilon$$

$$3: FP = \beta_0 + \beta_7 CDA + \beta_8 CAE + \varepsilon$$

Where: ACI = Accurate Cost Information

CDA = Cost Driver Analysis

CAE = Cost Allocation Effectiveness

FP = Firm Performance

ACOM = Accountant Competency

TECG = Technology Growth

$\beta_1, \beta_2, \dots, \beta_4$ = Intercept

$\beta_1, \beta_2, \dots, \beta_8$ = Parameter estimates - independent variables, mediating variables, and antecedent variables.

ε = Error term.

4. DATA ANALYSIS, TEST OF HYPOTHESES AND DISCUSSIONS OF RESULTS

Data collected for the study were analysed to achieve the research objectives:

Descriptive analysis

Research objective 1 : To determine the extent of adoption of activity-based costing in selected manufacturing firms in Kwara state.

To determine the extent of adoption of activity-based costing in the selected manufacturing firms the respondents were asked to indicate the extent of adoption of ABC in their firms using five Likart scale that ranges from: Never used (1), Rarely used (2), Sometimes (3), Most of the time (4) to Always used (5).

Table 1 : Statistics on adoption of activity-based costing.

Mean	3.2963
Std. Error of Mean	.23291
Std. Deviation	1.71155
Minimum	1.00
Maximum	5.00

Source: Researcher's SPSS analysis (2015)

The result of the answer to the above question is shown in Table 1. From the table, the mean of the adoption of ABC is 3.2963. This indicates that manufacturing firms sampled averagely adopt activity-based costing. On the number of the sampled firms practicing ABC, 10 out of 28 firms sampled indicated they are practicing this system; this translates to 35.71% rate of implementation.

Regression analysis of the Models

Research objective 2: To evaluate the influence of activity-based costing implementation on accurate cost information

Model 1: Activity - based costing implementation and Accurate cost information.

Table 2 : Model 1 REGRESSION RESULTS SUMMARY

Model 1	Co-efficient	Standard error	t.statistics	Probability	V.I.F
Constant		0.512	1.557	0.126	

Independent					
Variables:					
C.D.A	0.258	0.164	1.73	0.085	1.845
C.A.E	0.482	0.129	3.292	0.002	1.845
R ²	0.467				
Adjusted R ²	0.443				
F-statistics	20.110				
Durbin Watson Statistics Statistics	1.949				

Dependent Variable: ACI

Source: Researcher's SPSS analysis (2015)

Table 2 shows the regression result summary of model 1 shows the relationship between ABC implementation dimensions (cost driver analysis and cost allocation effectiveness) and accurate cost information. As contained in the Table, the regression model computed R² and the adjusted R² are 0.466(46.6 %) and 0.443(44.3%) respectively. This implies that 46.6% variation in accurate cost information is explained by change in cost driver analysis and cost allocation effectiveness.

The coefficient estimate of cost driver analysis calculated at 0.258 shows that a unit change in cost drivers analysis will induce 0.258 change in accurate cost information. Also, the co-efficient estimate of 0.482 computed for cost allocation effectiveness will induce 0.482 unit change in accurate cost information.

Furthermore, the two variables: cost driver analysis and cost allocation effectiveness are statistically significant at 1% and 10% respectively. The table also shows that the model is well fitted as shown by the calculated F-statistic of 20.110 (p<0.05).

The implication of the result of model 1 is that:

Ho1 : Activity-based costing implementation dimensions do not significantly influence accurate cost information.

Research objective 3: To determine the influence of technology growth and accountant

competency on activity-based costing implementation;

Model 2a: Accountant competency and technology growth and cost driver analysis.

Table 3 : Model 2a REGRESSION RESULTS SUMMARY

Model 2(a)	Co-efficient	Standard error	t.statistics	Probability	V.I.F
Constant		.368	4.564	.000	
Independent					
Variables:					
ACOM	.814	.123	5.697	.000	2.037
TECG	-.087	.121	-.606	.548	2.037
R ²	.569				
Adjusted R ²	.549				
F-statistics	28.412				
Durbin Watson	1.256				

Dependent Variable: CDA

Source: Researcher's SPSS analysis (2015)

Table 3 shows the summary results of the regression 2a model indicating the relationship between accountant competency and technology growth and cost driver analysis. From the table, R^2 and the adjusted R^2 computed are 56.9% and 54.9% respectively. This result shows that 56.9% variation in cost driver analysis can be explained by the change in accountant competency and technology growth.

The co-efficient estimate of accountant competency calculated at 0.814 shows that a unit change in accountant competence will induce the same rate of change in cost driver analysis. Also, a unit change of -0.087 in cost allocation effectiveness will induce the same negative rate of change in cost driver analysis. It will be noted in the analysis of the model that accountant competency is significant at 1%, while technology growth is not significant (0.548). Nevertheless, in overall, the model is significant as it shows an F value of 28.412.

Model 2b: Accountant competency and Technology growth and Cost allocation effectiveness.

Table 4 : Model 2b REGRESSION RESULTS SUMMARY

Model 2(b)	Co-efficient	Standard error	t. statistics	probability	V.I.F
Constant		.490	1.507	.139	
Independent					
Variables:					
ACOM	.376	.149	2.575	.013	1.779
TECG	.378	.147	2.592	.013	1.779
R^2	.473				
Adjusted R^2	.449				
F-statistics	19.732				

Durbin Watson Statistics	1.568
--------------------------------	-------

Dependent Variable: CAE5

Source: Researcher's SPSS analysis (2015).

Table 4 shows the summary results of the regression 2b model indicating the relationship between accountant competency and technology growth and cost allocation effectiveness. From the table, the R^2 and the adjusted R^2 computed are 47.3% and 44.9% respectively. This results show that 47.3% variation in cost allocation effectiveness can be explained by change in accountant competency and technology growth.

The co-efficient estimate of accountant competency calculated at 0.376 shows that a unit change in accountant competence will induce the same rate of change in cost allocation effectiveness. Also, a unit change of 0.378 in technology growth will induce the same rate of change in cost allocation effectiveness.

The F- statistic computed at 19.732 is equally significant at 1% which implies that the model is well fitted.

The implication of the results of the two models- 2a and 2b put together is that :

Ho2: Accountant competency and technology growth do not significantly influence activity based costing implementation is not accepted.

Research objective 4 : To assess the impact of activity-based costing implementation on firm's performance.

Model 3: Activity based costing implementation and Firm's performance.

Table 5 : Model 3 REGRESSION RESULTS SUMMARY

Model 3	Co-efficient	Standard error	t. statistics	probability	V.I.F
Constant		.470	-.014	.989	
Independent Variables:					
CDA	.113	.182	.855	.397	2.430
CAE	.731	.144	5.511	.000	2.430
R ²	.674				
Adjusted R ²	.660				
F-statistics	46.574				
Durbin Watson Statistics	1.873				

Dependent Variable: PERFORMANCE

Source: Researcher's SPSS analysis (2015)

Table 5 shows the summary results of the regression 3 model indicating the relationship between activity-based costing implementation on firm's performance. From the table, the R² and the

adjusted R^2 computed are 67.4% and 66% respectively. This result shows that 67.4% variation in firm's performance can be explained by change in ABC implementation (cost driver analysis and cost allocation effectiveness), while 32.6% are explained by the error term.

The F - value computed at 46.574 implies that the model is well fitted. Cost allocation effectiveness is statistically significant but cost driver analysis is not significant. On the overall, the model is significant at 1% as indicated by the F value.

The implication of the above results of the model is that:

Ho3: Activity based costing implementation does not have significant impact on firm's performance is not accepted.

Discussion of Findings

The findings of this study are discussed in line with the research questions raised in the study.

Research Question 1: What is the current state of adoption of activity-based costing in the selected firms?

The findings of this study shows that activity based costing practice among the manufacturing firms sampled was fairly moderate. This is indicated in table 1 showing the statistics of the adoption of activity-based costing. The study indicates that most of the sampled firms were not using ABC. This study is not consistent with the work of Imeokparia (2013) which found that ABC was mostly used by listed manufacturing companies in Nigeria. One of the reasons could be the size of the firms studied as most of the firms sampled were medium-scaled companies and were not quoted on the Nigerian Stock Exchange. Another reason could be lack of competent and qualified accountants to install ABC in the sampled firms.

Research Question 2 : What is the influence of activity- based costing implementation on accurate cost information ?

The findings of this study show that the implementation of activity-based costing has a positive influence on accurate cost information. It then implies that activity-based costing can determine the quality of cost information. This is so because ABC implementation has a positive correlation with accurate cost information.

Research Question 3: What is the influence of accountant competency and technology growth on the implementation of activity-based costing implementation?

The findings of this study show that accountant competency is a key factor for the implementation of activity-based costing in manufacturing firms. The result of model 3 shows a very strong coefficient implying that accountant competency does influence the implementation of activity-based costing. This findings is in line with the study of Rattanaphaphtham and Ussahawanitchakit (2010). The findings of this study also show that technology growth does not positively influence the implementation of activity-based costing . Management of manufacturing firms would then have to focus attention on accountants' training to enhance activity-based costing implementation.

Research Question 4: What is the impact of activity- based costing implementation on firms' performance?

The findings of this study indicate that the successful implementation of activity-based costing can lead a firm to have enhanced performance. The results of the analysis of model 4 shows that particularly cost allocation effectiveness has a strong impact on firm's performance. This implies that the more the effectiveness of a firm's cost allocation system, the more profitable a firm is. Cost driver analysis has little effect on the firm's performance. However, on overall, the implementation of activity-based costing has some impact on a firm's performance. The findings of this study is in consonant with the findings of Kennedy and Affleck – Graves (2001); Rattanaphaphtham and Ussahawanitchakit (2010); and Imeokparia (2013).

5 SUMMARY, CONCLUSION AND RECOMMENDATIONS

This study focused on the investigation of the influences of activity-based costing implementation on accurate cost and firm performance. The result showed that activity-based costing implementation is significantly and positively related to firm's performance. Furthermore, accountant competency and technology growth have been found to influence the implementation of activity based costing system. It can be concluded that with the right training of accountants and improved technology in a firm, ABC can effectively be implemented to achieve accurate cost information and enhanced performance.

In the light of the findings of this study, the following recommendations are made;

First, manufacturing firms that have not adopted the use of activity-based costing system should do so as their performance can be enhanced with the use of this modern costing system.

Second, manufacturing firms should regularly train their accountants in activity –based costing as this is essential for its effective implementation.

Thirdly, Accounting professional bodies should improve on depth of their Mandatory Continuous Professional Education (MCPE) program so that it can include the implementation of modern costing techniques such as activity-based costing and activity -based management in manufacturing companies.

Lastly, further research involving larger samples of manufacturing firms should be carried out in order to confirm or reject the findings of this study. Also, a study could be carried out to find out the extent of application of ABC in the service industry.

REFERENCES

Akinleye, G.T & Adigbole , E.A., (2012). The use of ABC system for product cost determination in manufacturing companies. *African Studies Review*, 336 -356.

Aulakh, P.S., Kotabe, M & Teegen, H. (2000). Export strategies and performance of firms emerging economics: Evidence from Brazil, Chile, and Mexico, *Academy of Management Journal*, 43 (3), 342-361.

Barney, J. (1991), Firm resources and sustained competitive advantages, *Journal of Management*, 17 (1),

99-120.

Blocher, E., Chen, K. & Lin, T. (1999). *Cost Management: A Strategic Emphasis*, The McGraw-Hill Companies, Inc, New York:

Camal, Z., Acar, A.Z. & Tanviverdi, H. (2006). Identifying organizational capabilities as predictors of growth and business performance. *The Business Review Cambridge*, 5(2),109-116.

Chenhall, R.H., & Langfield –Smith, K. (1998),The relationship between strategic priorities, management techniques and management accounting: An empirical investigation using a system approach, *Accounting Organizations, and Society*, 23 (3),243-264.

Cooper, R. and Kaplan, R. (1988a): Measure Costs Right: Make the Right Decision. Harvard

Business Review, 66 (5), 96-103.

Devellis, R.F. (1991). *Scale Development: Theory and Application*, *Applied Social Research Methods*, series 26, Sage, Newbury Park:

Drury , C. & Tayles M., (2005). Explicating the design of overhead Absorption procedures in UK organizations. *The British Accounting Review*. 37(1), 47-84.

Drury, C. (2004), *Management and cost Accounting*, 6th ed., Benford Row, Thompson Learning, London.

Ebben, J.J. & Johnson, C.A. (2005), Efficiency , flexibility, or both? Evidence linking strategy to performance in small firms. *Strategic Management Journal*, 26, 1249-1259.

Fei, Z.Y & Isa C.R (2011). The effect of activity –based costing on firm performance, A study among Chinese manufacturing firms. *Journal of Applied Sciences Research* , 7 (9), 227-254

Garrison, R. & Noreen, E. (2000), *Managerial Accounting*, 9th ed. McGraw-Hill Inc, Irwin.

Gopalakrishnan, S. (2000). Unravelling the links between dimensions of innovation and organizational performance. *The Journal of High Technology Management Research*, 11 (1), 137 –153.

Grant, R.M. (2001), The Resources – Based theory of competitive advantage: Implication for strategy formulation, *California Management Review*, Springs, 114 – 135.

Hansen, R. & Mowen M. (2000), *Cost management: Accounting a control*, 3rd ed., South Western College Publishing, Ohio.

Harrison, G. (1992). The Cross- cultural Generalizability of the Relation Between Participation, Budget Emphasis And Job Related Attitudes. *Accounting, Organization and Society*, 17 (1),1-15.

Hassan, M.U., Shaukat, S. , Nawaz, M.S., & Naz, S. (2003). Effect of innovation types on firm performance: An empirical study on Pakistan manufacturing sector and *Pakistan Journal of Commerce and Social Sciences*,7 (2), 243 – 262

Hilton R.W. (2002). *Managerial Accounting: Creating value in a dynamic business Environment*, 5th ed.,

Mc Graw Hill, New York.

Hopper, T. & Mayor, M (2007). Extending Institutional Analysis Through Theoretical Triangulation: Regulation and Activity Based Costing in Portuguese Tele Communications. *European Accounting Review*.

16(1), 59 -97.

Imeokparia L.(2013). *Activity-Based Costing and The Performance of Manufacturing Industries in South-Western Nigeria*. Unpublished Doctoral Thesis in Business Administration , Babcock University, Nigeria.

Innes, J. & Mitchell, F. (1990): *Activity Based Costing: A Review with Case Studies*. London: Chartered Institute of Management Accountants (CIMA).

Itner, C.D., Lanen,W.N, & Larker, D.F, (2002).The association between activities –based costing and manufacturing performance. *Journal of Accounting Research*, 40 (3), 711-725.

Jarvenpaa, M. (2007). Making business partners : A case study of how management accounting culture was changed. *European Accounting Review* 16(1): 99 -142.

Johnson, H. T., (1990). Beyond product costing: A challenge to cost management's conventional wisdom. *Journal of Cost Management*, (4)(3), Fall. 15-21.

Kaneko, P., Ussahawanitchakit, P & Muenthaisong, K.,(2013). Strategic target costing effectiveness and goal achievement: Empirical evidence from exporting gem and jewelry Business in Thailand, *International Journal of Business Strategy*, 13 (3), 127-157.

Kennedy, T. & Affleck-Graves. J. (2001). The impact of activity -based costing techniques on firm performance. *Journal Of Management Accounting Research*. 13, 19-45.

Maelah, R. & Ibrahim, D.N. (2006). Activity- based costing (ABC) adoption among manufacturing organizations: The case of Malaysia. *International Journal of Business and Society*, 7, 70- 101.

Mc Gowan, A.S. (1998). Perceived benefits of Activity –based cost management implementation. *Accounting Horizons*, 12(1), 31-50.

Otley, D. (1980). The Contingency Theory of Management Accounting: Achievement and Prognosis. *Accounting Organization and Society*, 5 (4), 413- 428.

Otley, D. (1994). Management Control in Contemporary Organizations Towards a wider Framework. *Management Accounting Research*, 5 (3 - 4) , 289-299.

Rattanaphaphtham, K., & Ussahawanitchakit, P. (2010). Activity – based costing effectiveness: How does it influence competitive advantage and performance of Thai- Listed firms ? *International Journal of Business Strategy*, 10 (2), 1-21.

Sakurai, M. (1996). *Integrated Cost Management: A Companywide Prescription for Higher Profits and Lower Cost*, Productivity Press ,Portland, M Oregon.

Singh, R., Sandhu, H.S., Metri, B.A, & Kaur R. (2010). Relating organized retail supply chain management practices, competitive advantage and organizational performance. *The Journal of Business Perspective*, 14 (3),173 – 190.

Teeche, D.J. , Pinsno, G., & Shuen, A. (1991) Dynamic capabilities and strategic management, *Working Paper, Centre for Research in management*, Barkley.

Tontiset, N. & Ussahawanitchakit, P. (2009). Effects Of Cost Management Effectiveness on cost Information Usefulness, Corporate Competitiveness and Firm Success: An Empirical Study of Thai Manufacturing Firms, *Journal of Academy of Business and Economics*,9 (2) , 91-101.

Turney, P. (1996). Activity-based costing: The performance breakthrough, Kogan Page Ltd, London

Wickramasingle , D. & Alawattage, C., (2007). *Management Accounting Change : Approaches And Perspectives*, New York: Rutledge.

**WORKING CAPITAL MANAGEMENT AND
PROFITABILITY OF SMALL AND MEDIUM
ENTERPRISES (SMES) IN NIGERIA – Agbeyangi, B. A.,
Jinadu, O., & Akinde, M. A.**

***Principal Lecturer, Accountancy Department, The Federal Polytechnic Iaro, Ogun State, ACTI, B.Sc and M.Sc Accounting, Ph.D student in Accounting at Covenant University Ota, Ogun State.**

Email: baagassociates@yahoo.com

****Senior Lecturer, Accountancy Department, Rufus Giwa Polytechnic Owo, Ondo State. ACTI, B.Sc and M.Sc Accounting, Ph.D student in Accounting at Covenant University Ota, Ogun State.**

Email olugbengajinadu@yahoo.com

*****Principal Lecturer, Accountancy Department, The Federal Polytechnic Iaro, Ogun State ACTI, HND Accounts, B.Sc and M.Sc Economics, M.Sc Finance, Ph.D student in Finance at Covenant University Ota, Ogun State.**

Email: kanmi5@yahoo.com

Abstract

This study examines the effect of working capital management on the profitability of small and medium enterprises (SMEs) in Nigeria. Secondary source of data collection was used in carrying the study. Data were analyzed using inferential statistics and by employing multiple regression analytical model which was used to evaluate the relationship between SMEs profitability and liquidity as well as financial variables. Conclusion was reached by testing the hypotheses using Fisher's F test. The findings of this study showed that there was no significant relationship between efficient working capital management

and profitability of small and medium enterprises (SMEs) in Nigeria. Furthermore, there was no significant relationship between efficient working capital management and the liquidity of small and medium enterprises (SMEs) in Nigeria. The study recommended that enterprises should hasten up the collection of cash from credit sales and strong credit policy system that would ensure that account receivables period is shorter than account payables period while the policy should be adopted by the management of SMEs.

Key Words: Liquidity, profitability, small and medium enterprises (SMEs), working capital management.

Introduction

Small and Medium Enterprises (SMEs) remain one of the most dynamic forces and agents of economic growth and development of a nation. Small and medium scale enterprises generate or contribute a large amount to the Gross Domestic Product (GDP) of such nation. In Nigeria, small and medium enterprises are all around us, the fact that little capital is required to start small and medium enterprises make them the most popular type of business (Apicha, 2012).

Several small and medium enterprises (SMEs) in Nigeria fail a little while they were established. Most of them fail due to poor financial management, especially working capital management. Most small and medium enterprises (SMEs) do not engage their working capital in such a way as to enjoy maximum profit. The combination of account receivables management strategy, cash management, account payables and most importantly inventory management strategy left much to be desired by the small and medium enterprise (Kehinde, 2011).

The contribution of the small and medium enterprises (SMEs) to Gross Domestic Product (GDP), employment generation and industrial development in the Nigerian economy is low as compared to its contemporaries Asia emerging economies such as China, Indonesia, Malaysia, India, and Singapore despite its resource endowment (SMEDAN/NBS, 2012 and Sanusi, 2012). The major challenges facing SMEs development in Nigeria are lack of access to external finance, infrastructural facilities, poor financial management and working

capital management (including cash) and poor record-keeping which result to low profitability, growth and failure of many SMEs (Kehinde, 2011 and SMEDAN/NBS, 2012).

Working capital management is a managerial accounting strategy focusing on maintaining efficient levels of both components of working capital i.e. current assets and current liabilities. Working capital management ensures a company has sufficient cash flow in order to meet its short-term debt obligations and operating expenses. Implementing an effective working capital management system is an excellent way for Small and Medium Enterprises (SMEs) in Nigeria to improve their earnings (Sumaira, 2013). Efficient working capital management is necessary for achieving both liquidity and profitability of an enterprise. A poor and inefficient working capital management leads to tying up funds in idle assets and reduces the liquidity and profitability of an enterprise. Efficient liquidity management involves planning and controlling current assets and current liabilities in such a manner that eliminates the risk of inability to meet due short-term obligations and avoids excessive investment in these assets (Adediran, Josiah, Bosun-fakunle and Imuzeze, 2012).

To remain liquid enough and meet short term payables, management of working capital is essential for the small and medium enterprises. But, can proper working capital management make small and medium enterprises (SMEs) more profitable? Different measures and processes need to be improved to increase profitability and liquidity through working capital. Researchers on the topic have concentrated their research work on the impact of working capital management on the performance of manufacturing companies without looking at how working capital management affects the growth of small and medium enterprises. Some researchers tried looking at effects of working capital on SMEs performance and working capital management in manufacturing industry. Mohammad (2011) investigates working capital management and profitability on textile industry, Zubair and Mohammad (2013) investigate the impact of working capital management on profitability of cement industry, Osundina (2014) investigates working capital and profitability of quoted food and beverages manufacturing firms in Nigeria, Pedro and Pedro (2003) also investigate the effects of working capital on SME profitability in

Spain. No researcher has really looked into working capital management of SMEs in Nigeria. It was also observed that some research work that was done on SMEs in Nigeria in the past lack some factual data and adequate sample size.

However, the general objective of the study is to examine and evaluate the relationship between working capital management and profitability as well as liquidity on the following research questions: (i) To what extent does working capital management affects profitability of small and medium enterprises (SMEs) in Nigeria? (ii) How does working capital management affects liquidity of small and medium enterprises (SMEs) in Nigeria?

Literature Review

Working capital management and profitability are concern of all corporate entities large or small, listed or unlisted companies, manufacturing or service enterprises, but it is a crucial issue to be address by SMEs. Given the importance of the sector and the fact that majority of their assets are in working capital and their vulnerability to fluctuation. There are several studies on working capital management in relation to enterprise's performance, profitability and financing (Muhammad, Norhani and Rokiah, 2014).

In early 1960s to 1970s, the industrial policy of Nigeria placed greater attention on economics of scale. The large scale production were more cost effective thereby making large enterprises the bedrock of modern economy and considering small and medium enterprises as inefficient. This has changed today and in fact, small and medium enterprises are the engine of industrial development and have now gained more relevance and acceptance especially in Nigeria economy. Small and medium enterprises (SMEs) account for 70 percent of employment in the industrial sector and also promote indigenous technology in United Kingdom. Yet small and medium scale enterprises have not been given universal acceptable definitions despite the widely acceptable position that SMEs remain the formidable engine of growth and development of any nation (Olabisi, Sokefun and Oginni, 2012). Small and medium enterprises have been defined in various ways by various people and government agency just as it has been worked on in various ways by different nation. Micro business has been recognized, a small

enterprise is recognized as well as medium enterprises. The theoretical bases for this study are Contingency theory, Configurational theory and Cash holding theory, which are integrated, discussed and scrutinized by numerous scholars.

Contingency theory has dominated research until the 1970s. The theory demonstrates that attributes of environments, technologies, and structures interact to restrict the range of viable organizational forms. The basic assumption behind contingency models is that the best performance can be achieved when organizational structures match external contingency factors. In other words, "contingency models posit that effectiveness is highest where the structure fits the contingencies. Match causes effectiveness, mismatch causes ineffectiveness". Only those organizations that align their organization with the current environment achieve maximum output.

Configurational theory builds on the Contingency theory and it is also the offshoot of contingency theory. Conversely, configurational inquiry represents a holistic stance, an assertion that the parts of a social entity take their meaning from the whole and cannot be understood in isolation. Configurational theorists thus emphasize the alignment of different design parameters in the organization and its environmental context. As with previous Contingency theory hypothesis, the match between organizational design parameters and context variables will posit greater effectiveness and efficiency for organizations. At the same time, internal organizational design parameters such as work specifications, reward/incentive systems and coordination systems must likewise be brought into line.

Abel (2008) examines Cash holding theory by looking at the impact of working capital management on cash holdings of small and medium enterprises (SMEs), so as to derive the significant factors relating to working capital management which have an influence on the cash level of small and medium enterprises (SMEs). He tested these with a large sample of manufacturing small and medium enterprises (SMEs). He discovers that efficient working capital is positively related to cash holding.

Filbeck and Krueger (2005) highlight the importance of efficient working capital management by analyzing the working capital

management policies of 32 non-financial enterprises in the United States of America (USA). According to their findings, significant differences exist among enterprises in working capital practices overtime. Moreover, these working capital practices, themselves, change significantly within enterprises.

Eljelly (2004) empirically examines the relationship between profitability and liquidity, as measured by current ratio and cash gap (cash conversion cycle) on a sample of 929 joint stock companies in Saudi Arabia. Using correlation and regression analysis, he found significant negative relationship between the enterprise profitability and liquidity level, as measured by current ratio. This relationship is more pronounced for enterprises with high current ratios and long cash conversion cycles. At the industry level, however, he found that the cash conversion cycle or the cash gap is of more importance as a measure of liquidity than current ratio that affects profitability. The enterprise size variable was also found to have significant effect on profitability at the industry level.

Singh and Pandey (2008) attempt studying the working capital components and the impact of working capital management on profitability of small and medium enterprises (SMEs) in India for period from 1990-2007. Results of the study showed that the current ratio, liquid ratio, receivables turnover ratio and working capital to total asset ratio had statistically significant impact on the profitability of Small and Medium Enterprises (SMEs) in India.

Rahman and Nasir (2007) argue that working capital management has its effect on liquidity as well on profitability of the enterprise and hence studied the effect of different variables of working capital management including the average collection period, inventory turnover in days, average payment period, cash conversion cycle and current ratio on the net operating profitability of Pakistani enterprises. Debt ratio, size of the enterprise (measured in terms of natural logarithm of sales) and financial assets to total assets ratio were used as control variables. Their results showed strong negative relationship between variables of the working capital management and profitability of the enterprise. It means that as the cash conversion cycle increases it will lead to decreasing profitability of the enterprise, and managers can create a positive value for the shareholders by reducing the cash conversion

cycle to a possible minimum level. They also found that there is a significant negative relationship between liquidity and profitability; that there is a positive relationship between size of the enterprise and its profitability; and significant negative relationship between debt used by the enterprise and its profitability.

Rahman (2006) investigates the relationship between the ability of enterprises to effectively manage its working capital components and their profitability. He examines the effect of the average collection period, inventory turnover in days, average payment period, and the cash conversion cycle on the enterprise's profitability. Using a sample consists of 94 Pakistani enterprises, he found a negative relationship between working capital components and enterprise's profitability impaling that an enterprise profitability is largely affected by the length of its cash conversion cycle.

Nazir and Afza (2009) investigate the relationship between the policies that enterprises adopt to deal with the working capital and enterprises profitability by using data on 204 Small and Medium Enterprises (SMEs) in Karachi. The result indicate a negative relationship between enterprises' profitability and its financing policies, enterprises that adopt an aggressive working capital policy generates a low rate of returns than that of those adopting a conservative working capital policy.

Saleem and Rahman (2011) posit that every enterprise has to maintain relationship while in conducting day to day operations hence they studied the impact of liquidity ratios on profitability of oil and gas companies in Pakistan. The results showed that there is a significant impact of only liquid ratio on ROA while insignificant on ROE and ROI. The results also showed that ROE is not significant affected by three ratios: current ratio, quick ratio and liquid ratio while ROI is greatly affected by current ratios, quick ratios and liquid ratio. The main results of the study demonstrate that each ratio (variable) has a significant effect on the financial positions of enterprises with differing amounts and along with the liquidity ratios in the first place. The study, therefore, recommended that enterprises need to maintain adequate liquidity as some portion of the enterprises' profitability will be divided to shareholders.

It should be noted that Lagos State Chamber of Commerce and Industry (LSCCI) have made a lot of effort to salvage the SMEs from dearth of finance to run their various businesses. Bank of Industry (BOI), in a bid to address financing challenges confronting small and medium enterprises in Nigeria has signed a memorandum of understanding with 10 deposit money banks on new framework to support the SME sector. The commercial banks include Access Bank Plc, Diamond Bank Plc, Ecobank Limited, Fidelity Bank Plc, First Bank of Nigeria Plc, First City Monument Bank Limited, Standard Chartered Bank Limited and United Bank for Africa Plc. Under the new framework, prospective customers of the Bank of Industry would access the bank's fund based on its risk acceptance criteria, while the commercial bank will provide capital to the SMEs based on agreed term under the framework and the banks' individual acceptance criteria (Soludo, 2008).

According to Gbandi and Amissah (2014) commercial banks, microfinance banks, international development agencies and some of its agencies are some of the institutions in the formal finance sector that have played very prominent roles in the financing of SMEs in Nigeria. Commercial banks remain the biggest source of finance for SMEs across the globe. However, many commercial banks are reluctant in financing SMEs because of perceived risks and uncertainties. In Nigeria the difficult economic environment, absence of appropriate managerial skills and lack of access to modern technology by SMEs have all contributed to the commercial banks reluctance to finance the sub-sector. The result of this reluctance is the steady decline in financing of SMEs in the country over the years. The CBN (2010) statistics show that commercial banks advances to SMEs have been on the decline over the years. Commercial bank loans to SMEs as a percentage of total credits decreased from 48.79% in 1992 to 0,15% in 2010 (Luper, 2012).

Similarly, merchant banks loans to SMEs as a percentage of total credits reduced from 31.2% in 1992 to 9.0% in 2000 (Achua, 2011). Many credit institutions have been established over the years by the government and its agencies. The objectives of these credit institutions have always been to improve access to finance by SMEs. Some of these institutions are the Nigerian bank for commerce and

industry (NBCI), National economic reconstruction fund (NERFUND), the Peoples bank of Nigeria (PBN) which has been referred to as government social lending, the community banks (CB) now microfinance banks, Nigerian export and import bank (NEXIM), and the Nigerian agricultural credit scheme . Others are the Small and Medium equity investment scheme (SMEEIS) which was actually a voluntary initiative in 1999 by the bankers' committee through CBN's moral suasion, to assist in providing finance to small enterprises, the small and medium enterprises credit scheme(SMECGS). In the 1980s, banks were mandated to set u p branches in the rural areas. The objective of this policy was to improve access to financial services (Soludo, 2008)

Lomanzi (2000) investigates working capital management in selected companies in Zambia and progressed on the assertion that liquidity and profitability are the two key goals in managing working capital. In general terms, working capital for the selected companies did not fair well. There was lack of proper linkages between working capital components.

Egbide, Uwuigbe and Uwuigbes (2013) investigate Liquidity Management and Profitability of Manufacturing Companies in Nigeria using both the partial correlation and regression analysis reveal that liquidity ratios measure by current ratio (CR), Liquid ratio (LR) and Cash conversion period (CCP) have a petite relationship with profitability measured by return on capital employed (ROCE). It also revealed that CR and LR are positively associated with ROCE, while CCP is negatively associated with ROCE.

Having reviewed the above literature, the researcher had formulated the following hypotheses:

H₀₁: There is no significant relationship between efficient working capital management and profitability of small and medium enterprises in Nigeria.

H0₂: There is no significant relationship between working capital management and the liquidity of small and medium enterprises in Nigeria.

Conceptual Model

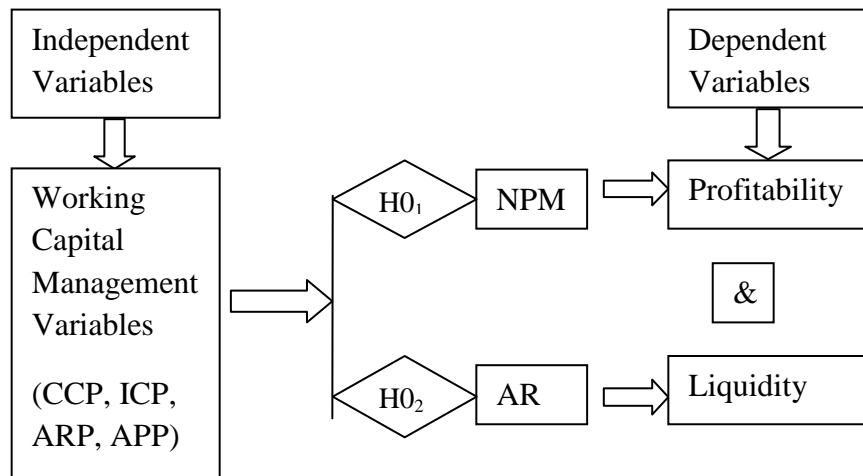

The conceptual framework on which this study is built is shown above. The independent variables are the components of working capital management and the dependent variables are profitability and liquidity. The model contains the following working capital management variables/proxies which are CCP, ICP, ARP and APP. From the above, two hypotheses are formulated as H0₁ and H0₂.

Methodology

This study adopted inferential research design. It describes and interpretes the true nature and current status of the problem of study. Secondary source of data collection was used. The target population of this study consists of small and medium enterprises (SMEs) in Nigeria. Non probability sampling technique was adopted with the use of purposive sampling to arrive at the sample size and the sample size consists of small and medium enterprises (SMEs) in Lagos State as a representative of others in Nigeria.

Analysis of data was carried out by employing multiple regression analytical models which were used to evaluate the relationship between SMEs profitability and liquidity and the financial variables while conclusion was reached by testing the hypotheses using Fisher's F- test and comparing the outcome of the results with already stated

hypotheses with the aid of statistical package for social sciences (SPSS), in drawing conclusion of the study.

To investigate the effect of working capital management on profitability and liquidity of Small and Medium Enterprises (SMEs) in Nigeria, the study developed two different adjusted models based on the two dependent variables i.e. profitability and liquidity.

MODEL 1

Small and Medium Enterprise's Profitability = f (Working Capital Management)

$$NPM_{it} = \beta_0 + \beta_1 * ARP_{it} + \beta_2 * APP_{it} + \beta_3 * ICP_{it} + \beta_4 * CCP_{it} + \epsilon_{it}$$

MODEL 2

Small and Medium Enterprise's Liquidity = f (Working Capital Management).

$$AR_{it} = \beta_0 + \beta_1 * ARP_{it} + \beta_2 * APP_{it} + \beta_3 * ICP_{it} + \beta_4 * CCP_{it} + \epsilon_{it}$$

Where:

NPM_{it}: Net Profit Margin

AR_{it}: Acid-test Ratio

CCP_{it}: Cash conversion period

ICP_{it}: Inventory conversion period

ARP_{it}: Account receivables period

APP_{it}: Account payables period

β_0 : Intercept of the equation

ϵ_{it} : Error term

Results and Discussion of Findings

The Fisher's F test was used. Given the fact that the P-value corresponded to the F value is lower than 0.065, it means that we

would be taking a lower than 6.5% risk in assuming that the null hypothesis (no effect of the four explanatory variable) is wrong. This also showed Used that the model was not statistically fit for the data. Since the P-value is 0.065 which is greater than 0.05, therefore, we accept the null hypothesis (H0) and concluded that the working capital management has no significant relationship on the profitability of SMEs in Nigeria.

In order to determine the relationship between the measures of profitability, the researcher conducted a multiple regression analysis. As per the SPSS generated, the regression model; $NPMit = \beta_0 + \beta_1*AR\text{Pit} + \beta_2*AP\text{Pit} + \beta_3*IC\text{Pit} + \beta_4*CC\text{Pit} + \epsilon$ (i.e. $Y_1 = b_0 + b_1X_1 + b_2X_2 + b_3X_3 + b_4X_4 + \epsilon$) was generated as follows: $Y_1 = 17.897 + (-0.017)X_2 + (-0.668)X_3 + (0.035)X_4 + \epsilon$

The Fisher's F test was used. Given the fact that the P-value corresponded to the F- value is lower than 0.945, it means that we would be taking a lower than 94.5% risk in assuming that the null hypothesis (no effect of the four explanatory variable) is wrong. This also showed that the model was not statistically fit for the data. Since the P-value is 0.945 which is greater than 0.05, therefore, we accept the null hypothesis (H0) and concluded that the working capital management has no significant relationship on the profitability of SMEs in Nigeria.

In order to determine the relationship between the measures of profitability, the researcher conducted a multiple regression analysis. As per the SPSS generated, the regression model; $NPMit = \beta_0 + \beta_1*AR\text{Pit} + \beta_2*AP\text{Pit} + \beta_3*IC\text{Pit} + \beta_4*CC\text{Pit} + \epsilon$ (i.e. $Y_1 = b_0 + b_1X_1 + b_2X_2 + b_3X_3 + b_4X_4 + \epsilon$) was generated as follows: $Y_1 = -34.016 + (3.224)X_1 + (0.085)X_2 + (18.788)X_4 + \epsilon$.

The Fisher's F test was used. Given the fact that the P-value corresponded to the F- value is lower than 0.922, it means that we would be taking a lower than 92.2% risk in assuming that the null hypothesis (no effect of the four explanatory variable) is wrong. This also showed that the model was not statistically fit for the data. Since the P-value is 0.922 which is greater than 0.05, therefore, we accept the null hypothesis (H0) and concluded that the working capital

management has no significant relationship on the liquidity of SMEs in Nigeria.

In order to determine the relationship between the measures of liquidity, the researcher conducted a multiple regression analysis. As per the SPSS generated, the regression model; $ARit = \beta_0 + \beta_1*ARPit + \beta_2*APPit + \beta_3*ICPit + \beta_4*CCPit + \epsilon$ (i.e. $Y_2 = b_0 + b_1X_1 + b_2X_2 + b_3X_3 + b_4X_4 + \epsilon$) was generated as follows: $Y_2 = 2.623 + (-0.10)X_2 + (-0.028)X_3 + (0.01)X_4 + \epsilon$

The Fisher's F test was used. Given the fact that the P-value corresponded to the F- value is lower than 0.860, it means that we would be taking a lower than 86% risk in assuming that the null hypothesis (no effect of the four explanatory variable) is wrong. This also showed that the model was not statistically fit for the data. Since the P-value is 0.860 which is greater than 0.05, therefore, we accept the null hypothesis (H0) and concluded that the working capital management has no significant relationship on the liquidity of SMEs in Nigeria.

In order to determine the relationship between the measures of liquidity, the researcher conducted a multiple regression analysis. As per the SPSS generated, the regression model; $ARit = \beta_0 + \beta_1*ARPit + \beta_2*APPit + \beta_3*ICPit + \beta_4*CCPit + \epsilon$ (i.e. $Y_2 = b_0 + b_1X_1 + b_2X_2 + b_3X_3 + b_4X_4 + \epsilon$) was generated as follows: $Y_2 = 2.726 + (-0.142)X_1 + (-0.001)X_2 + (-1.293)X_4 + \epsilon$.

Conclusion

In conclusion, this work has empirically established that a number of key variables affected the profitability and liquidity of Small and Medium Enterprises (SMEs) in Nigeria. These include Inventory Conversion Period (ICP), Cash Conversion Period (CCP), Account Receivables Period (ARP) and Account Payables Period (APP). These variables either affect profitability and liquidity of SMEs in Nigeria positively or negatively depending on how effective and efficient working capital has been managed by the organization. Besides, since Nigeria has a beckoning large market size that promises the highest return on investment, according to most recent study, we strongly enjoin investors and market players to surge into this market with

their accumulated funds to provide needed investment funds to the small and medium enterprises (SMEs) in Nigeria. It was revealed from this study that there is poor liquidity in most small and medium enterprises (SMEs) in Nigeria and the poor working capital flow of the SMEs have precluded them from the ability to compete effectively in the market. This study concluded that there is no significant relationship between working capital management and profitability and liquidity of SMEs in Nigeria.

Suggestion for Further Studies

There are several research areas for further research that were identified during the course of this study. One of the research areas was to focus on the financing of working capital and how SMEs in Nigeria could optimize the capital mix to ensure maximal profitability and liquidity. Optimal financing of working capital could improve profitability and liquidity and also reduce potential financial risk exposures and effectively decrease an enterprise's interest liabilities and make it easier to find financing.

References

Abel, M. (2008). Working capital management; SME; cash holdings; cash substitute; cash conversion. *University essay from Mittuniversitetet/Institutionen*.

Adediran, A., Josiah, M., Bosun-fakunle, Y. and Imuzeze, O. (2012). The impact of working capital management on the profitability of small and medium scale enterprises in Nigeria. *Research journal of business management*, 1-9.

Afromedia Statement of Account 2007 - 2011.

Apicha, B. (2012). Model of Thai small and medium-sized enterprises organizational capabilities: Review and verifications. *Journal of management research*, 4(3): 15 – 42.

CBN, (2012). Development finance. Retrieved from <http://www.cenBank.org/devfin/acgst.asp>

- Egbide, B., Uwuigbe, O. and Uwuigbe, U. (2013). Liquidity management and profitability of manufacturing companies in Nigeria. *IOSR Journal of Business and Management*, 9(1): 13-21.
- Eljelly, A. (2004). Liquidity-profitability trade off: an empirical investigation in an emerging market. *International journal of commerce and management*, 14(2): 48-61.
- Enyi, P. (2006). Applying relative solvency to working capital management: the break even approach: toward better working capital management. Punjagutta, *the Icfai University press*
- Filbeck, G. and Krueger, M. (2005). An analysis of working capital management results across industries. *American journal of business*, 20(2): 11 – 20.
- Gbandi, E. and Amissah, G. (2014). Financing options for small and medium enterprises (SMEs) in Nigeria. *European Scientific Journal*, 10(1): 327-340
- Kehinde, J. (2011). Effective working capital management in small and medium scale enterprises (SMEs). *International journal of business and management*, 6(9): 271-279.
- Lomanzi, L. (2000). An inquiry into working capital management in selected companies in Zambia.
- Luper, I. (2002). Does bank size matter to SMEs financing in Nigeria? *International Journal of Business and management tomorrow* 2(3):2-5.
- Mohammad, M. (2011). Working capital management and profitability of textile industry. *ASA university review*, 5(1): 115 – 132.
- Mohammad, M., Norhani, A. and Rokiah, I. (2014). Impact of working capital management and corporate governance on the profitability of small and medium-sized entities in Nigeria: a proposed model. *International journal of science, commerce and humanities*, 2(5): 53-65.
- Naid hotel statement of account 2007 - 2011.

- Nazir, M. and Afza, T. (2009). Impact of aggressive working capital management policy on firms'profitability. *The IUP journal of applied finance*, 15(8): 19 – 30.
- Olabisi, J., Sokefun, A. and Oginni, B. (2012). Kaizen cost management technique and profitability of small and medium enterprises (SMEs) in ogun state, Nigeria. *Research journal of finance and accounting*, 3(5).
- Osundina, J. (2014). Working capital and profitability of quoted food and beverages manufacturing firms in Nigeria. *European journal of accounting, auditing and finance research*, 2(3): 10 – 21.
- Pedro, J. and Pedro, M. (2003). Effects of working capital on SME profitability in Spain.
- Rahman, A. (2006). Relationship between efficiency level of working capital management and profitability of firms in the textile sector of Pakistan. *COMSATS institute of information technology Islamabad*.
- Rahman, A. and Nasir, M. (2007). Working capital management and profitability - case of Pakistani firms. *International review of business research papers*, 3(1): 279 – 300.
- Saleem, Q. and Rahman, A. (2011). Impacts of liquidity ratios on profitability: ase of oil and gas companies of Pakistan. *Interdisciplinary journal of research in business*, 1(7): 95-98.
- Sanusi, L. (2012). Nigeria's economic development aspirations and the leadership question: is there a nexus? *Central Bank of Nigeria online publication*, 1 – 18.
- SMEDAN/NBS. (2012). Collaborative survey report on micro, small and medium enterprises (MSMEs) in Nigeria: *Online copy*, 1 – 183.
- Singh, J. and Pandey, I. (2008). Impact of working capital management on the profitability. *Journal of financial economics*, 6(4): 62 – 72.
- Soludo, C. C.(2008). Making finance work for the poor. A convocation paper retrieved from <http://www.sec.gov.ng>

Sumaira, T. (2013). Impact of working capital management on profitability of textile sector of Pakistan. *Proceedings of 3rd international conference on business management*, 1 – 29.

Zubair, A. and Muhammad, Y. (2013). Impact of working capital management of profitability of cement industry. *International journal of contemporary research in business*, 5(2): 384 – 390.

**COST-EARNINGS SENSITIVITY ANALYSIS AND
MEASUREMENT OF RETURNS TO INVESTMENT IN
PHYSICIANS' RESIDENCY PROGRAMME IN NIGERIA –
Alozie, C. E. & Nwaorgu, I. N.**

**DEPARTMENT OF ACCOUNTANCY, FACULTY OF MANAGEMENT
SCIENCES; ANAMBRA STATE UNIVERSITY –ULI, ANAMBRA
STATE**

ABSTRACT

The paper evaluates investment to education and training of consultant medical doctors trained within last two decade and current practising in the Nigerian health sector. The objectives include estimation of total expenditure outlay committed in producing consultant physicians, life-cycle income-earnings and measuring the rate of private financial returns to intellectual capital investment of average Nigerian consultant doctor. Mixed research design and method adopted. These comprised of secondary data on doctors remunerations extracted from secondary sources and primary data on generated through research instrument(s) were employed. Techniques of analysis include the financial modelling and estimation processes, particularly numerical analysis - percentage method, averages, cash-flow annual return, pay-back period. Some advanced techniques are discount cash-flow and net present value method, gross and break-even point analysis, net terminal value - financial actuarial valuation (NTV). Result of first test indicates that N48 million (average least cost method) is invested to produce a consultant physician; whereas total gross earnings for 13 years' post-registration earnings which equated total duration of medical studies is N64 million; which indicates that earnings exceeds outflow for an equal duration. Gross earnings of Consultant doctors for about three and half years fully replenish current medical education subsidy worth N27 million, which confirms that subsidy to medical education is insufficient. Third, pay-

back period or break-even point of up-front outlays and fund inflows is approximately 15 years, and it is an indication that current remuneration package of doctors in Nigeria is inequitable and poorly priced. Net terminal worth newly qualified consultant-physician that practice in Nigeria is N102 million with internal rate of private return at 17 percent. At this private rate of return, return to investment to human capital for Nigeria is slightly higher than the African region's 10.5percent rate of returns. In conclusion, to education and training of medical doctors in Nigeria is financially and economically viable. However, inequitable remuneration system, provision of subsidy to medical students and under-funding impact negatively to Nigeria's health system development.

Keywords: Residency Medical Doctors' Education, Investment, Human Capital Development, financial costs, Returns, Nigeria

1. 1 Background to the Study

Individuals, household units and government invest substantial resources in education and human development, and there is substantial that it is important investment. Individuals who are more educated earn higher wages or attract higher labour prices; richer countries have higher levels of literacy and educational attainment, experience rapid economic growth as they have often invested heavily in education and in health care services. From career planning, intellectual capital and professional development perception, whenever secondary school graduates in consultation with their families or sponsors make decision of a course of study to medicine in particular they probably do not realize that such decision leads to intellectual capital investment in development of soft project. Such project idea or conceptualization often crystallizes into a specialized project development, a life-long occupation / career and business planning that may later turn into a medical practice – for instance, a hospital complex in the health sector.

Empirical studies conducted in other countries provided evidence that financial and economic costs committed in the education, man-power training and human capital development in producing each physicians through the Medical Schools is a variant of intellectual capital. However, in practice, these variants of expenditures in human capital

is often ignored (Becker, 1964). Many writers on human capital development or human resource accounting have argued that such neglect have arisen because costs of schooling and pan-power training – including on-the-job training are treated as current expense item by the firms, households and the states (Fiamholtz, 2012). Similarly, Xiao (2010), Kadvand *et al* (2011) reasoned that since the costs incurred in education and training is traditionally considered recurrent expenses by the society, these expenditures are not duly recorded / treated capital investment but as routine expenses.

Health policy, planning and funding falls under the direct supervision of the Federal Ministry of Health FMOH, then the Ministries of Health in the States. The statutory bodies responsible for regulation of the medical profession in Nigeria are; “The Medical and Dental Council of Nigeria” (MDCN); Nigerian Medical Association (NMA) (established since 1962); Federal Ministries of Health and at the States – who jointly own public universities - Teaching Hospitals and the National Universities Commission (NUC) – the regulator University education.

Conventionally, undergraduate education and professional training in medicine is facilitated in the University Teaching Hospitals and these teaching / specialist hospitals are mainly owned, controlled and managed by the National Health Authorities – the Federal Ministry of Health and in some cases, the Ministry of Health in the States. Consequently, the coordination, regulation, monitoring and supervision of medical education in Nigeria is jointly administered by the MDCN, the FMOH, the SMOH on one side and the authorities of the respective universities offering courses in medicine and the management of the Teaching Hospitals / Medical Schools. Of late, some private universities in Nigeria have joined in the establishment of University Teaching Hospitals – the leadership of such private universities and the management of such Teaching Hospitals / Medical Schools also participate in the administration of undergraduate medical education in Nigeria. The structure of the available medical schools and professional training in medicine simply implies that it is public sector driven and quasi-government regulated. This is the practice and trend in most parts of the World.

Nigerian Medical Schools predominantly admit prospective students straight from post primary schools, attracting the best cadet high school leavers. The undergraduate students undergo a six year course of study, usually

broken into two phases, the basic medical studies and the clinical studies. Upon successful completion of the basic medical and clinical studies; and successful completion of the required academic and professional degree of Bachelor of Medicine and Bachelor of Surgery (MBBS), the new physician undergoes another one-year compulsory internship in approved health / hospital facility, which is the final lap of his / her professional training. Thereafter, goes through and induction ceremony called the Oath of medical practice, which is preceded with the issue of license of practice as a general medical practitioner in the first instance and a registration with the Nigerian Medical and Dental Council, Nigeria (MDCN) and Nigerian Medical Association (NMA). Newly graduated physicians proceed for one-year compulsory community service (NYSC) before taking-up appointment or setting up a private medical practice.

1. 2 Social Statistics of Nigeria's Health Sector and Trends

The trend in socio-economic and financial statistics in Nigeria's health sector indicated the following: (i) The total number of medical doctors produced in Nigeria as at 2014 is 39210; the number of accredited and partially accredited Medical Schools is 28; the ratio of a doctor to the population is 39 per 100,000 while there is the patient / doctor ratio of one single medical doctor to 101,108 patients. The HIV prevalence rate is estimated at 4.6 percent of the population. In terms of funding of public health services, Federal Government's annual allocation is less than 5% of the total annual expenditure budget and perhaps the combined Federal and State budgetary allocation to the health sector is about 55 of the aggregate national public expenditure. According to Osotimehin (2009), about 67 percent of the total annual budgetary allocation to the health sector is spent on tertiary health care, the teaching hospitals and urban areas. Nigeria's on-line Health journal (2011) reported further that out of the 39210 doctors trained in Nigeria, about 4000 of them are practising in the United States and United Kingdom respectively. The HIV prevalence in the nation's population stands at about 4.6 percent.

1.3 Statement of the Problem

The problems facing Nigeria's Health Systems Development, and of medical education and training, and production of the much needed high level man-power through medical consultants residency programme is more critical than that of the undergraduate medical

education and training. These problems range from inadequate funding of the medical schools / teaching hospital – specifically medical research activities of the Nigerian public universities; insufficient institutional (government) expenditure in terms of subsidy extened to residents; poor remunerations for medical doctors coupled with inadequate facilities lack of and incessant strike actions; and lastly, lack of reliable data / information on average or unit cost of producing medical consultants / medical experts in Nigeria (Kiriga et al (2006), AMA (2009) Blewett, Simith and Caldis (2007), Chen, (2012). A low annual turn-out of doctors and specialist (consultant) doctors have resulted acute shortage of doctors in some states / public health services in Nigeria in and lack of data on costs of medical education. The association of resident doctors (NASD), the academic staff union of universities (ASUU), and other representations from other bodies of medical professionals consistently alleged that their members in public service are under-remunerated (NMA, 2014, NARD 2014, Fasan, 2014). World Health Organisation (2000),reported that shortage of doctors in most African countries is attributed to the medical schools lacking capacity to train sufficient number of doctors, whilst Lui, Kinfu, & Dai-Poz (2008) explained that the exodus on inability government of low-income nations to retain doctors who choose to migrate abroad on reasons better career prospects.

Government budget and fund allocation to the health sector seems to be insufficient, therefore, education subsidies from government to medical students might be minimal, which is a huge factor militating against result-driven doctors's education in the Nigeran economy. Osotimehin (2009) affirmed acute paucity of reliable financial information of public expenditures of both undergraduate, medical residency and post-graduate programmes in Nigeria. Srivastava and Rao (2002), Tilak (1993a, 1993b, 2014) explained that public education subsidies is provided by every nation to encourage participation in higher education, and the predominance of the state subsidy is a regular feature of most education system. Kiriga, et al (2007), Dovlo and Nyonator (2007) stated that sufficient subsidies must be provided to medical students by governments to all medical students to ensure steady production of physician, reduce shortage

and brain –drain and retention of medical doctors in the public health service.

Thirdly, lack of information private spending efficiency or public expenditure efficiency to determine the demand for education of a physician and physicians in Nigeria with regards to ascertainment of the total expenditure committed in acquiring academic and professional education is relatively unknown, a phenomenon that compounded the situation. Chen (2012) explained that many doctors have found themselves repaying such study loans for several years after qualification, until their 50s, as a result of paucity of data on cost outlays of education in medicine. The situation is even worse in Nigeria where study loan schemes are not quite effective (Fasan, et al). Due to non-availability of education cost outlay, and the stream of cash inflows generation through the intellectual capital of a physician, it is practically impossible for investors or participants in medical education – either at micro-enterprise or macro-level to carry-out feasibility analysis to determine financial and economic viability of an investment medical doctors' education.

1.4 Objectives

The main objective is to analyse the estimated cost of training and earnings of medical consultants residency programme in Nigerian health sector: (1)

Estimate cost of education and training of the consultant physician, from undergraduate and residency programme totalling 13 years and income-earnings for equivalent period of years;

(2) Ascertain the total worth of government subsidy enjoyed by a consultant physician during both basic medicine and residency training programme and years earnings to replenish subsidy for those that serve in Nigeria;

(3) Simulate the gross earnings; net terminal value and rate of private financial returns on investment to education and training of medical residency in Nigeria.

1.5 Research Questions

(1) How much is government's subsidy cost committed in education and training of a consultant doctor and how many years income earnings will equate this cost outlay doctors?

(2) What is the actual amount (value) of government subsidy expenditures committed to education and training of average medical doctor in Nigeria commensurate to his /her income earnings for seven years post registration service?

(3) What is the terminal actuarial net-worth; rate of private financial return to investment on the intellectual capital of Nigerian trained physician; and does the rate of return in Nigeria compare favourably with other developing economies?

1.6 Hypotheses

The hypotheses were formulated to guide facts and data gathering for the analyses in the study. The hypotheses are stated in null form as follows:

H₀₁: Human capital investments of the consultant physicians cannot be fully re-couped with his / her total post registration career earnings for 13 years' equivalent duration of academic and professional trainings

H₂: Government subsidy expenditures to consultant doctors education is not greater than his / her total earnings for equivalent number years spent during the entire medical education and training.

H₃: Total cost outlay of human capital development of consultant physicians cannot be fully replenished from the gross income-earnings within a period equivalent to the total duration of medical training.

H₄: The rate of private financial return to investment in medical doctors' education for Nigeria is less than the current global average rate of 11 percent alongside the net present value.

1.7 Scope and Limitation

The scope of paper is restricted to estimation of total cost of investment to the education and clinical practice training of medical doctors that completed both the basic academic education and training and the medical doctors residency programmes on or before 2013; and duly registered with the Medical and Dental Council of Nigeria. It concentrated mainly on assessment and appraisal of cost outlays and earnings of consultant doctors, commencing from the time of basic medical studies up-to the period of the completion of residency programmes. It is only those that completed the studies with the specified standard duration that were considered in this instance. Costs of schooling from primary and secondary education - outside

tertiary medical education of consultant doctors were excluded. Streams of cash-inflows from earnings is restricted to post-qualification start up salary and income earnings for 35 active (life-long) service years, were adopted in estimation of the inflows until the age of 60.

1.8 Organisation of the Study

The paper has been arranged in five sections. Section one contains general introduction. Second two contains literature review and relevant empirical studies. Section three is devoted to the methodology of research; while the fourth chapter dwells elaborately on the data presentation, analysis and summary of results. Summary and recommendations are presented in the last section.

SECTION 2: REVIEW OF CURRENT LITERATURE AND RELATED STUDIES

Conceptual, theoretical and empirical literature on cost of education and training has generated enormous interest in several disciplines, from education to economics, development studies, management studies, accounting and particularly in medicine remain as provided in the paper one. However we will elaborate briefly on medical consultants' residency programmes here, but we are skipping major conceptual issues. Becker (1975), Psachapoulous (1993) Fiamhotz (1961, 1980) Scheffler (2008) and several others identified the main cost components of cost education to include the following: programmes fees, reading and research materials, hostel, or boarding and feeding, transportation and local conveyances, education allowances paid by employers, laboratory and scientific resource facilities, opportunity cost for income –earnings forgone income. More specifically, in the field medicine the operating, administrative expenses, cost of consumables and based salaries of faculty and residents (resident doctors) are normally absorbed as direct cost medical education (Scheffler, 2008, Roth 2012, Franizini et al)

2.1 Contributions from Divergent Schools of Thought on Human Capital

Rather than engaging the audience with the extended conceptual issues and perspectives on investment in education and training; on human capital development and the perception of human capital accounting, we provide a

subtle review or synthesis of the contributions of scholars from the pertinent disciplines on the subject matter. The ***Contributions of economic school to Conceptual Literature of Human Capital:*** The classical macroeconomic theory contributed the development conceptual framework and perspectives of human capital in several ways. This school of thought provided logical basis of an all-inclusive concept of capital which includes human capital was first established or developed by Irving Fischer in 1906 but was eventually popularised by Shultz, Becker, and Arrow (Kwon, 2009). The concept treats all sources of income streams of human beings and physical assets and even mineral resources as forms of capital. In other words, natural resources reproductive capacity and plants of producers utilised in production of consumer goods and commodities as well as such human forms as the inherited and acquired abilities of producers and consumers are considered as capital. The concept was further expanded, developed and established as the theory of investment in human capital development was developed and widely established by Shultz (1959), Becker (1964) Mincer (1994, 1998) and others followed later.

Human Capital Accounting - Accountants' Perspective:

The conceptual framework within the realms of accounting research initially laid emphasis on assessment and measurement of the impact or contribution of employees training, work experience, on-the-job training and learning curve effect on the productivity and profitability of firms. Eric Fiamholtz is one of the earliest researchers on human resources accounting which was part of his doctoral thesis in 1961 (Porwal, 2006). Some of the pioneer accounting researchers on accounting for human capital or Human resources accounting are includes Lev and Schwartz (1971), Hermanson (1974).

Caplan and Landekick (1974) cited in Porwal, 2006), posited that there are two major reasons for which human resource accounting has received and still receiving so much attention and growing interest in research of this subject matter in the contemporary periods. First, developments in the modern organization theory have made it apparent that there is genuine need for reliable and complete information that can be used in improving and evaluating the management of human resources and also the performance of the organisation as an entity (Ekot and Ogala 2011). Second, there is that the traditional framework of accounting is the process of been expanded to include a much broader set or sets of measurement of

values – monetary values; of revenues, income and expenditure; of assets and liabilities; and other forms of financial and economic analysis and evaluations than was thought possible in past years. The financial information on human resources costs although commonly recorded and reported as recurrent operating costs are used by producing firms, commercial enterprises and even non-profit seeking organisations in measurement of performance, as control technique on activities and management decisions (Fiamholtz, 1980).

2.3 Comparison Review of Medical Education and Training in Nigeria/Other nations

The system and process of medical education and training of the physicians in Nigeria is inherited or diffused from Nigeria's colonial administration—the British / the United Kingdom's pattern of medical education, certification, licensing and registration. In Nigeria as it is the practice in the UK, and Kenya, admits mint secondary school graduates with requisite passes in core science subjects into the undergraduate programmes in medicines, which normally runs for six straight and un-broken academic sessions culminating to the award of dual MB BS professional first degree in medicine. This is intertwined with additional one-year internship in clinical practice and health care delivery management.

The modalities for medical education in the United States and the countries that adopting the USA system is substantially different. Under the US medical training, prospective medical students are required to possess a good first degree in life sciences for enrolment into the medical school programmes which last for at least four years (minimum) and as long as 12 years for the most challenging specialisations. Cost of medical education in the USA is substantially more expensive and capital-intensive and financially prohibitive than what obtains in Nigeria. There is also a remarkable difference in the areas of education financing – that is, in terms of availability of students loans by the state and financial institutions and in terms of repayment. Medical students in the US amass huge debt in the course of the medical training whereas the costs in Nigeria is mild with little credit facilities.

2.4 Theoretical Literature

Arrow (1963) discussed several aspects of the healthcare market that makes products and services offered therein unique. Arrow notes that an individual's demand for medical care, unlike food and clothing, tends to be irregular, and unpredictable. Arrow (1963) noted further that entry into the medical fields is restricted by certification and licensing from appropriate national regulatory bodies, but at the same time encouraged by education subsidies provided to medical students. The health care markets distinguish health services from other goods and services markets. Thus, the society must treat the health care market – that is, the health / medical care sector - as a special-case economic entity, and if the society should understand the economic forces directing the health sector (Arrow, 1963). Richard Scheffler' (2008) is an important text that offers a historical evolution of the USA's health care market. Scheffler *et al* analyses many aspects of the changing health / medical care in the twentieth century. He notes that between 1900 and the mid-1960, the United States suffered from significant shortages of doctors. This trend spawned or spurred the government to increase medical school funding in 1963 and by 1975, that public health policy had resulted in building / instituting some forty new market medical schools and the expansion of many older ones.

2.6 Empirical Reviews

Empirical studies devoted mainly on medical residency programmes drawn from other countries are considered here, because of the dearth of such research from our country, and moving forward motivated the authors to consult such empirical literature. The relevant empirical studies that estimated costs of investment in medical residency programmes with earnings (cash in-flows) in CBA and measurement of private and social returns to investment include: (i) Roth (2012) (ii) Blewett, Smith and Caldis (2001)

Roth's (2012) study conducted at the University College, Los Angeles at Berkeley (USA), with the objective to determine the private internal rate of returns and the net present values (NPV) of those investments across a range of medical specialities. The researcher calculated these values under two different assumptions and used two discount rates in the computation of the NPV. The technique of analysis is a hybrid of the Net Present Value and the Discounted Cash Flow (DCF) technique were the analytical method employed in the study. The specialities included Radiology, Oncology, Orthopaedic surgery, Paediatrics and Rheumatology etcetera. The authors

applied cost construction methodology which computed the cost of teaching, from the information on programme description, residency enrolment, faculty and residents' salaries and benefits; operating costs and the associated administrative charges. Surveys of faculty and residents were conducted to determine approximate time spent in teaching activities, access to institutional and departmental financial records was obtained and used in quantifying costs associated with undergraduate education and training.

The result of the cost estimation and tests revealed that the cost of residency training (cost of didactic teaching, directive clinical supervision, teaching-related preparations and administration, plus, the support of the teaching programme was estimated at US\$75,070 per year for each carrying student. This cost is less than the estimated replacement value of the teaching and clinical services provided residents, worth US\$103,436 per resident fellow per year. Sensitivity analysis with different assumptions regarding resident replacement cost reimbursement rates varied with the cost estimates, but generally identified the anaesthesiology residency programme as a financial asset. The author in conclusion stated that medical education remains a very profitable investment, particularly in the USA.

Blewett, Smith and Caldis's (2001) empirically an estimation of direct cost of graduate medical education sponsored by Minnesota State's Department of Health, in the United States. The objective of study was to determine the average cost of med the physicians trained and qualified from the medical schools in that state in 2005. Secondary data extracted from health accounting reports, self-reported cost accounting data of the sponsored institutions presented in their financial report for the 1997 financial year. The study assessed the relative contributions of resident medical specialists, faculty and administrative costs to primary care, surgery and the combined programmes of radiology, emergency medical services, anaesthesiology and pathology (REAP). Results showed that direct cost of clinical training in FY97 per medical doctor's clinical training was US\$130,843, equivalent of N13 million. Faculty costs were allocated at 52%, residents 26% and administrative charge 24%. Primary care programmes average costs were lower than those of surgery and REAP, but proportionately included more administrative costs. In conclusion, as policy makers assess government subsidies on graduate medical education, more

detailed data will required. Self-reported data are cost effective and efficient than the more detailed and costly time-and-motion studies. The findings of paper are very usefulness for estimation cost of investment in medical education and in determination of the level of subsidization of medical education in the Minnesota State's Health Department. This estimation process and resource costing of the UT-Medical School / Teaching Hospital can be replicated in Nigeria for cost ascertainment and assessment of earnings of medical doctors trained and practising in Nigeria – and in the present Nigeria's focal study.

The information drawn from the reviewed of empirical studies are quite scintillating and appropriate to the current study in several dimensions. First, these studies provided supporting evidence that studies on involving estimation of costs, earnings and measurement of rate of returns to medical education and training have been conducted other countries but apparently none for Nigeria. Second, the studies CBA analysis on investment in medical education is necessary in health policy formulation, planning and financing of health care programmes and for the operations and management of universities medical schools / teaching hospital complexes in Nigeria as in other countries. Studies in this topical issues is a central issue in gauging private spending efficiency of investment in doctors education and household / micro-level and macro-level decisions. Finally, analysis, evaluation and measurement of returns to investment on medical education and human capital development is an invaluable information for the development and improvement of health sector accounting and national health accounts including health insurance in Nigeria.

Section 3: METHODOLOGY

The study is designed specifically to produce cost estimation of investment to medical education, life-cycle career earnings of consultant doctors and rate of private returns of a cohort recently qualified specialist physicians that completed residency programmes before the end of 2014. Theoretical and methodological or analytical framework and estimation process adopted in the paper seeks to establish total expenditure of the average medical consultants-in-training now specialists, streams of earnings inflows in appraisal of investments to the intellectual capital of doctors in Nigeria earnings. Then, test, measure and evaluate financial viability of the investment and returns appropriately.

3.2 Research Design (Citations)

The descriptive and analytical approach is adopted. Secondary data were utilized for the analysis data collections (Scheffler, 2008; Rotth 2012). Psacharopolous (1994) stated that estimation of education expenditure and expected revenue flows (cash in-flows) in every project or venture are the key factors in investment appraisal for decisions. Whilst Becker (1964) explained that investment outlays of a person's academic and professional education in accounting have very wide and varying cost profiles.

3.3 Theoretical Framework

This study on education and development of highly skilled man-power in health systems development links human capital theory with human and economic development and productivity of employees in the nation's health sector as propounded by Gary Becker (1961, 194 and 1975); Arrow (1963) and Richard Scheffler' (2008). Becker et al suggests that education and training raises the productivity of employees, but more specifically the skilled workers (experts) by imparting useful knowledge and skills, hence raising workers' future income by increasing their lifetime earnings (Becker, 1964). Becker (1964), Shultz, 1958 (cited in Porwal (2006) and Mincer (1974) provide some explanations linking investment and professional training of the skilled workers with improved remunerations. Therefore, the theory of human capital or human capital development provides the foundation on which the costs of investment for the education and training of medical doctors; and the returns (private and social returns), but specifically private or individual returns in the context of this paper is erected.

The methodological and analytical approach are very important components of the human capital theory because these procedures must be followed in measuring private spending efficiency in education, thus, it is determined by the rate of returns to investment to education. Psacharopolous (1994) identified two commonly used methods as the "elaborate" and Mincer's "earnings" methods developed by Mincer (1974) as an appropriate and reliable approach to appraise investment to education and measuring of retruns. He further counselled that an understanding of the estimation method(s) and processes are very important for interpreting rate of return patterns. He inferred that the method adopted by the authors on this subjected matter is often dictated by the nature of available data and that the

estimation and measurement models for human capital might not be suitably applied in analysis of investment physical assets. The elaborate method is preferred, hence its adoption in this study.

3.4 Data Sources and Collection

Secondary data were utilized in the study. These data sets relate to expenditures on medical education, earnings of medical practitioners were obtained from the medical schools / teaching hospitals of selected public universities where both undergraduate and post graduate residency programmes medical are offered. The medical programmes in the sampled institutions have valid accreditation by the Medical and Dental Council of Nigeria (MDCN); and the National universities Commission (NUC) respectively (MDCN, 2015). These information and data were extracted from the official records in the Registrar's department, Student Affairs Directorate of the relevant universities and the Medical Schools. In addition, we collected information on the professional fellowship examination, registration, enrolment; professional examination and qualification requirements of "Consultant Doctors" from the National Postgraduate Medical College, Lagos.

More specifically, secondary data pertaining to salaries for housemanship, medical doctors and resident doctors were obtained from the Bursary department of the relevant institutions, located in South West, South-East and South-South zones, namely: University of Benin – College of Health Sciences, Ugbowo, Benin; Nnamdi Azikiwe University's (Awka) Teaching Hospital / Medical School, Nnewi and Obafemi University – College of Health Sciences, Ile Ife, Osun State. These facts / information verified from some of the graduated students and practitioners through direct interactive discussions. These valuable data sets were generated by the research team and were duly extracted information on individual's up-keep expenses, incidental expenses, transport and conveyances, feeding for those not accommodated in school hostels, sundry expenses during the entire duration of their undergraduate medical education.

3.5 Sampling Selection Procedure

Sampling selection of tertiary institutions where doctors' residency and post-graduate studies in medicine are offered in Nigeria were drawn. Three public universities with good track record in offering medical

consultants' residency programme in the country were selected. In order to estimate fairly and an accurate / reliable accurate total expenditure outlays of medical education up-to the residency training, four consultant medical doctors each that graduated from sampled medical schools were drawn, making a total of 12 students (8 males and 4 females). The list of these tertiary institutions is given in table 1, in appendix page of this paper. The sample surveys of the universities-medical schools in Nigeria were drawn from only three out of the six geopolitical zones, with at least one university medical school representing a zones.

3.6. Medical Education - Direct and Indirect Residency Costs

Medical students are normally availed the use of the specialized medical laboratories, clinical laboratory, clinical materials, drugs and medicaments, and the research resources of their institutions Teaching Hospital complex (Scheffler, 2008; Rotth 2012)). This is in addition the direct contact hours of the Faculty members, consultants, the resident medical research fellows – those undertaking the professional fellowship examination of their respective sub-specialization the associated costs a commuted on full-time equivalent (FTE) for these categories of experts. Operational and administrative expenses of the medical school, faculty and residents salaries and emoluments are normally included in the cost outlay of residency programmes (Roth, 2012). Private and public costs in education he incurred either by participant's direct expense and indirect or imputed cost (*Becker et al*); while public costs are those costs borne by the state. Social costs on the other hand, arise from the negative spill-over effect of a particular productive activity including education (*Psacharopoulos, et al*). There are other social benefits that are often derived from the operation of private project as a result of education and training.

3.7 Estimation Process

Financial modelling, mathematical simulations and sensitivity analysis is invoked, and duly followed in the series of estimation process are as follows:

- * cost construction of the relevant up-front costs / expenditures to medical education
- * Estimation of gross salary earning and net salary savings living expense allowance

- * Computation of cash-flows for Break-Even point is without cost of funds, increments
- * 5% annual salary increment; 5% interest on saved salary of 25% of gross and cost of fund 4% applied in rate of return
- * CBA Sensitivity analysis used gross income-earnings and net terminal values

3.8 Model Development and Specification

In order establish the correspondence between the estimated total cost of investment to medical education and doctors' earnings, we follow the traditional "elaborate method" as suggested by Psacharopolous (1993) and is expressed as follows:

$$1) \sum^n = [(R_{n1} + R_{n2} + R_{n3} + \dots R_{n-n}) - (C_{n1} + C_{n2} + C_{n3} + C_{n-n})] = O, \text{ or } < 1, > 1 \dots n \dots (3.1)$$

$$2) \sum^n = [(R_{n1} + R_{n2} + R_{n3} + \dots R_{n..n}) - (C_{sn0} + C_{sn1} + C_{sn3} + C_{sn-n})] = O, \text{ or } < 1, > 1 \dots n \dots (3.2)$$

$$(3) \sum^n = [(R_{n1} + R_{n2} + R_{n3} + \dots R_{n-n}) - (C_{n1} + C_{n2} + C_{n3} + C_{n-n})] = x \text{ (Years)} \dots \dots (3.3)$$

$$4) \sum^{35} /_{t-i} Ri - Ci / (1 + r)^{n=35} = O \dots \dots (3.4)$$

(a) where: $R_{n1}, R_{n2}, R_{n3} \dots R_{n-n}$ = income earnings for relevant years; then, $C_{n0}, C_{n1}, C_{n2} \dots C_{3n} - C_n$ represents the streams of outflows for costs incurred from Year 0, 1, n for Model I system equation. For model equation 2, $R_{n1}, R_{n2}, R_{n3} \dots R_{n-n}$ as earlier stated equation model one and $= C_{sn0}, C_{sn1}, C_{sn2} \dots C_{sn3} - C_{sn-n}$ represents streams of government subsidy spending enjoyed by medical student in the course of their programmes to capture total outflows for the costs incurred from Year 0, up-to completion period and the spread of doctors earnings to fully recovery of outlay; and 'x' Years represents the pay-back period in years. No interest is charge as cost of fund and no salary increment is applicable in equation models 1, 2 and 3.

(b) where: R_i is the career salary income earnings in Year i ; C_i represents the cost incurred year 1, and 'r' represent the appropriate rate of return on investment in medical education within 10 years (post registration cash inflows (PRE) and also the Net Terminal Value (NTV) at the end of 35 years services. Please refer to the assumptions for the methodology. The first term in the system equation represent the revenue and cost streams of medical doctors with average age of 25 through to the age of 60 or maximum active service of 35 years excluding the period of post-graduate residency training. The method adopted for computation of rate of returns to investment to education, originally developed by Fein and Weber (1963, cited in Roth, 2012), but a modified version, which incorporates net savings of an expert's annual earning with interest has been used here

3.9 Techniques of Data Analysis and Software system

Technique of analysis employed include simple numerical analysis, cash-flow pay-back period analysis, sensitivity analysis, gross income earnings method, discounted cashflow, net present value method, and net terminal value (NTV) used in appraisal of human capital investment. It is the procedure followed in measuring the net terminal value of consultant doctors career earnings professional practice cycle in 35 years that terminates at 60. The relevant tools of analysis were duly facilitated with the aid of 'Comput-Stat and other suitable financial modelling packages / software application packages and Actuarial Valuation tables, in the serial computations undertaken.

3.9 Basic Assumptions

Key assumptions incorporated into the data sets used analyses:

- 1) The total cost of outlay of the basic medicine and residency programme is 13 years.
- 2) The opportunity cost of the basic and residency programme is N1.8 and N2 million
- 3) Stipend for Youth Service and extra income of doctors in service year is disregarded.
- 4) Average age of medical students at entry is between 17 / 18; average doctor's age is 25
- 5) A standard retirement age put at 60 with a maximum of 35 years of active service.
- 6) Cost of funds is 4%; annual salary increment is 5% and also 5% on net savings.

Section 4: Analysis and Results

The estimated expenditure outlays for the relevant academic and professional training programmes in medicine of consultant doctors in Nigeria (both the undergraduate segment and specialists' residency programme) on one side and life-cycle salary earnings for 35 active services years used in data analyses in the paper are summarized in Tables 1, 2, 3, 4 and 5, as provided in the appendix. It provides, in a simplified format, minimum costs committed by residents. It is pertinent to that data sets on the estimation total expenditure the first seven consecutive years duration of the basic studies in medicine, with the additional six years of residency (minimum) brings the total duration to 13 years which we used in the cost and benefit sensitivity analysis and appraisal of soft project investment of the medical consultant education.

4.1 Results of Analyses and Tests

- 1) Test 1 Result: N54.00 m < N76.80m million ; thus H_{01} is rejected and H_{a1} is accepted
- 2) Test 2 Result: H_{01} is rejected and since H_{a2} N27 million in 13 years < consecutive salary of N78.8 million in 13 years. H_{02} is rejected and H_{a2} is accepted.
- 3) Test 3 Result: Break-Even Period is 10.5 years or 11 Years approx: 13 years > 11 years; thus H_{03} is rejected and H_{a3} is accepted / adopted.
- 4) Test 4 results: 17% > 11%; H_{04} is rejected and H_{a4} accepted.

4.2 Discussion of Results

Estimated total earnings in 13 consecutive years amount is worth N78.8 million, compared to total cost outlay of N54 million (a least cost construction method). From the result of this first test, based on gross income earnings, investment in education of medical doctors in Nigerian economy is financial viable.

Given the medium-term recovery or pay-back period of government subsidy to medical education clearly demonstrated that government's contribution to education and production of medical doctors locally is inadequate. It is apparent that this low and minimal financial support to medical students acts as dis-incentive to potential student to enroll into the study of medicine and by extension, contributed to low annual turn-out and shortage of medical doctors in the country. By

implication, the State should that sufficient subsidy is given to medical students because doctors not only render essential medical services in domestic economy but a huge export human export and foreign exchange inflows (Kiriga et al)

The pay back period occurring around the 11th year signifies that medical education is quite capital intensive, with sub-optimal returns from the Nigerian model. This result may serve as useful reference information guide relevant government authority to review the remuneration and emoluments of the medical experts – since government sectors is the highest singular employers of doctors in this climate. The break-even point for the cost and benefit which picks at of 11th years of services for specialist doctors is also sub-optimal but considered fairly viable.

With an average rate of private financial returns to investment outlay to consultant physicians' education and man-power development in the Nigerian estimated at 17 percent from the result this paper suggests that an encouraging rate. This result indicates that returns on doctors' education in Nigerian is better than those for other countries in Sub-Saharan African region which currently stands 11 percent and 11.2 percent for the OECD countries. The results from the international studies on cost of undergraduate / graduate medical education in medicine / health sciences in very exorbitant and on the average, within the range of US\$ 36,000 per academic year in Kenya – an African country and low-income country to about US\$60,000 in public medical schools in USA compared to US\$1000 or N1.2 million for Nigeria.

Section 5: Summary, Conclusion and Recommendation

Prior to this study the cost of investment in medical doctors and residency programme is relatively known—if not unknown in Nigeria, by the participants themselves and or their sponsors, the tertiary institutions hosting these course programmes and produce the doctors might be even be fully aware of the cost implication of the activities undertaken in their place, while government(s) that provide the bulk of funding for the health sector, teaching hospital and the public universities through the NUC are not likely to possess reliable financial and social statistical data need for health policy and planning. It is equally a useful source of information for health insurance scheme. The study provides useful information for national health sector accounting for improved health service accounting and financial

management in Nigeria and information to guide government to provide suitable working environment and working conditions / remunerations for health professionals..

5.1 Summary of results

(1) Result of the first test indicates that N48 million (average least cost method) is invested to produce a consultant physician and total gross earnings for 13 years' post-registration earnings equating the total duration of medical studies is N64 million.

This shows that the income earnings for 13 years which is equal to the duration of total study programme exceeds cost outlay.

(2) Gross earnings of consultant doctors for consecutive eight years (approximately) can fully replenish government subsidy spends to medical students (basic and residency studies inclusive) worth N27 million. Perhaps this signifies that the current subsidy funding to medical students' education is inadequate.

(3) Third, pay-back period (break-even point) of the cost outlays and fund inflows is approximately 15 years, and it is an indication that current remuneration package of doctors in Nigeria is inequitable and poorly priced.

(4) Net terminal worth of newly qualified consultant-physician that practice in Nigeria is N102 million with rate of private return at 17 percent (Internal rate of return). Life cycle gross 'income-earnings' is N482 million.

Based on the rate, the return to investment to human capital for Nigeria is slightly higher than the African region's 11 percent (approx) rate of return

5.2 Conclusions

The conclusion to be drawn from the result of the study is that the medical doctors in the public health service in Nigeria are poorly remunerated. Government subsidy expenditure for an average medical doctor /resident doctor's is considered grossly inadequate and a source of disincentive to medical research. The combined effect of poor remuneration, poor working conditions and inadequate subsidy and improper funding of medical schools and the programmes lead to agitations by medical experts, strike actions and brain drain. These factors contribute to under-development of Nigeria's health sector. Despite long duration of studies leading to qualification, certifications and registration of the physicians and specialist doctors in Nigeria;

huge financial burden and challenging working conditions, investment in medical education is worthwhile.

5.3 Recommendation

The paper recommends that: (i) Stakeholders in the tertiary education system, the accounting professional and accountants who interface in the education and health sector, government agencies responsible for the health sector, and endeavour to provide timely and reliable financial information on the operating financial reports and annual financial statements for rational economic decisions

(ii) Government should increase the subsidy in the education of medical doctors and huge and as much as possible increase health budget and funding of the medical schools / health institutions

(iii) Government and stakeholders in the health labour market should consider enhance the remuneration packages of doctors and provide suitable equipment / enabling environment for medical experts to practice. Further research studies on health sector funding, national health accounts / accounting and appraisal of the intellectual capital investment of health professionals in the Nigerian economy need to be intensified.

REFERENCES

Abia State Health Systems Development Project, Health System Development Project II (HSDP II)'s Report, Umuahia, Abia State (January).

Aigbokhaevbolo, O.M. and Oghuma, R. I. (2004): Budgets and Economic Development in the 4th Federal Republic of Nigeria, Enugu; Nigerian Researchers Forum, Enugu State University of Science & Technology.

American Accounting Association (AAA) Committee on Presentation of Accounting Report (1966). "A Statement of Basic Accounting Theory".

American Accounting Association (AAA) Committee (1974), "Report of the AAA Committee on Accounting for Human Resources, Accounting Review, Supplement 49; 115

American Medical Association of Colleges (AMAC) (2014), Report on Developments in Medical Education and the State of Medical Schools.

Ajovi, Scot-Emuakpor (2012), The Evolution of Health Care System in Nigeria: Which Way Forward in the Twenty-first Century, Department of

Paediatrics and Human Development, Pediatric Hematology / Oncology, Michigan State University, East Lansing, MI, USA.

Arrow, K (1963), "Uncertainty and the Welfare Economics of Medical Care ". American Economics Review, 53 (5); 941 – 973. (Cited in Rod, N. (2012, The Costs and Returns to Medical Education)

Becker, G. S. (1975), Investment in Human Capital: Effects on Earnings. (Chapter 2 of the on-line reproduction of the author's original text on Hum Capital)

Becker, G. S. (1993), 'Human Capital: A Theoretical and Empirical Analysis with special reference to Education'. (3rd Edition), Chicago University Press

Becker, G. S. (2003), "Human Capital": A Definition. The Concise Encyclopaedia of Economics, / Library of Liberty: <http://www.econlib.org>

Blewett, L.A, Smith, M.A., and Caldis, T.G. (2001), Measuring the Direct Cost of Graduate Medical training in Minnesota. Journal of Academic Medicine, 76 (5) May, 446 – 52

Chen, P. (2012 ed.), Medical Education is a Health Policy Imperative; Editorial Commentary in the Editorial Page, New York Times (June, 9).

Davidson, A.W. (1989): *Parry's Valuation & Investment Tables*, Estate Gazette, London (11th Edition)

Fiamholtz, E.G. (1974). Human Resources Accounting. Los Angeles, Dickenson Publishing, page 190.

Fiamholtz, E.G. (1980). "The Processes of Human Resource Accounting (HRA) in Managerial Accounting.

Fiamholtz, E.G., Bullen, M. L., and Hua, W. (2002), Human Resource Accounting and Future Implications: Journal of Managerial Decisions; 40 (9) 947–954

Franzini, L., Low, M.D., and Proll, M.A. (1997), "Using a Cost-Construction Model to Assess the Cost of Educating Undergraduate Medical Students at the University of Texas-Houston Medical School, Journal of Medical Research, 116 (8); 221 – 243

Franzini, L., and Berry, J.M. (1999), A Cost-Construction Model to Assess the Total Cost of Anaesthesiology Residency. *Journal of Medical Research*, 57 (7); 3 – 3

Gammon, E, and L. Franzini (2011), "Revisiting the cost of Medical student education; A Measure of Experience of the University of Texas – Houston Medical school, Texas..

Goodwin, M.C., Gleason, W. M., and Kontos, H.A. (1997), "A Pilot Study of the Cost of Educating Students at Virginia Commonwealth University; *Journal of Medical Research*, 72 (3), 211 -217

Hermanson, R. H. (1964), *Accounting for Human Assets*, Occasional Paper No.14, Graduate School of Business Administration, Michigan State University (cited in Porwal, P S. (2006) (3rd edition) textbook on Accounting Theory, Chapter 21).

Kiriga, Akpa, Lenity, Nyoni and Seddoh (2006), The Cost of Health Professionals 'Brain – Drain' in Kenya. *BMC Health Services Research*; 689 (doi 10.1186/1472-6963 – 6- 89).

International Public Sector Accounting Standards Board (IPSASs) (2010): *Handbook of International Public Sector Accounting Pronouncements*, (2010 edition), IFAC, New York.

Jones, R.F and D. Korn (1997), "On the Cost of Financing a Medical Student" *Journal of Academic Medicine*; 72 (3) 200 – 2

Lucas, R. (1988), On the Mechanism of Economic Development. *Journal of Monetary Economics*, 22 (1) 3-42.

Lui, J. X, Kinfu, Y, and Dal-Poz, M (2008), Forecasting the Global Shortage of Physicians; an Economic and Needs-Based Approach. *BMC World Health Research Report*.

LinPak,J. (2011), *Man-power Planning, Rate of Returns analysis and the University Medical Schools: The Case of Australia*.

Medical and Dental Practitioners Act, 2004, *Laws of the Federal Republic of Nigeria of Nigeria*, Federal Government Publications, Abuja

- Mills, E J. Kanters, S. Hagopian, A. Bansback, N and Nachuga, J. (2011), "The Financial Cost of Doctors Emigrating from Sub-Saharan African; Human Capital Analysis. *Journal of Medical Research*, 53 (6), 323 -347.
- Mincer, J. (1997), The Production of Human Capital and Life Cycle of Earnings; Variations on a Theme. *Journal of Labour Economics*, 35, 9-37.
- National Health Insurance Act 1999, Laws of the Federal Republic of Nigeria, Federal Government Press, Abuja.
- National Youth Service Act (1973) Laws of the Federation of the Republic of Nigeria
- Organization for Economic Co-operation and Development OECD (2001), *The Well-Being of Nations: The Role of Human and Social Capital*, Paris. OECD
- Osotimehin, B., O. (2013-eds), Nigeria National Strategic Health Development Framework (2009 – 2015), Federal Ministry of Health, Abuja.
- Psacharopoulos, G. (1993), "Returns to Investment in Education: A Global Update" World Bank Policy Research, Working Paper 1057 (January).
- Psacharopoulos, G. (2005), "The Value of Investment in Education: Theory, Evidence and Policy", *Journal of Educational Finance*, Vol.32, No. 2, pp.113
- Porwal, P S. (2006), *Accounting Theory: An Introduction* (3rd edition). New Delhi. Tata McGraw-Hill Publishing Company Limited, Chapter 22 – Human Resource Accounting
- Rod, N. (2012), *The Costs and Returns to Medical Education*, University College, Berkeley.
- Saharawati, B. N. (2008), *The Rate of Return to Investment in Education: A Case Study of Polytechnic Diploma Graduates (in Malaysia)*, M.A. Degree Thesis, Department of Education, School of Educational Studies, Universiti Sains Malaysia.
- Scheffler, R. (2008)), "Is there a Doctor in the House"? Stanford, C.A. Stanford University Press

Shultz, T. W. (1961), Investment in Human Capital, American Economic Review, March, 45(57); 1-17.

Shultz, T. W. (1961), The Economic Importance of Human Capital in Modernization. Journal of Education Economics, 1 (1), 13 – 19.

Soyibo, A. *et al* (2005), National Health Accounts of Nigeria, 1998 – 200, Ibadan; Health Policy Training Programme, Department of Economics, University of Ibadan, Nigeria.

Tzu-Ju, A. P, Stephen, P. and Goran, R. (2007), Intellectual Capital and Performance Indicators: Taiwanese Health Sector. Journal of Intellectual Capital 8 (3) 538–556.

WHO, (2000) World Health Report 2000: Health Systems – Improving Performance, Geneva; World Health Organization

Nnadi Azikiwe University, Zaria, Website: abu.edu.ng

Obafemi Awolowo University, Ile-Ife; Website: oau.edu.ng.

University of Benin Website: www.uniben.edu.org

Foot Note: Majority of the old-dated referenced materials used by author for the research are considered as “Magnum Opium (evergreen and great research works on pertinent thematic issues most relevant for the current research paper; C.E. ALOZIE (April 2015)

(APPENDIX 1)

Table 1: FULLY ACCREDITED MEDICAL SCHOOLS HOUSING RESIDENCY

1. College of Medicine, Nnadi Azikiwe University, Awka, Anambra State
2. College of Health Sciences, Obafemi Awolowo University, Ile Ife, Osun State
3. College of Medical Sciences, University of Benin, Benin-City, Edo State

Sources: Authors Compilation (2015)

APPENDIX 2 - 4

TABLE 2: TEMPLATE OF MEDICAL STUDENTS COSTS 2005 -2006 / 2010

2A Direct Private Costs / Expenditure Items

COST (N)	Year -1	Year	2-6
Total			
The official tuition fees (2 Sessions) 100,000 120,000		20,000	
Application / Dues / Registration fees 100,000 140,000	40,000		
Textbook and other reading materials 1,000,000 1,300,000		240,000	
Accommodation and Feeding expenses 1,500,000 1,800,000	300,000		
Transport, and Conveyance expenses 600,000 720,000		120,000	
Laboratory / Research / Internet costs 750,000 900,000	150,000		
Purchase of Lap and Electronic Devices 750,000 900,000	150,000		
Clinical Clothing etcetera 400,000 480,000	80,000		
Salaries on study leave or Forgone Income 3,600,000 4,200,000		600,000	
Other incidental expenses 1,200,000 1,500,000	<u>300,000</u>		
SUB-TOTAL <u>12,000,000</u>	<u>2,000,000</u>	<u>10000,000</u>	
Public Costs (2B):			
Government Bursary Grant(s). 750,000 900,000		150,000	
Allocation of Imputed Public Cost			

FGN / States estimated @ 33% of (a)		200,000
1,200,000	1,200,000	
Faculty Resources Cost Absorption 33% (a)		200,000
1,200,000	1,200,000	
Residency Cost Absorption @ 33% of (a)		200,000
1,000,000	1,200,000	
Share of Clinical Operating @ 33% of (a)		200,000
1,000,000	1,200,000	
Share of Admin Expenses @ 33% of (a)		200,000
1,000,000	1,200,000	
Other direct public expenditures		<u>350,000</u>
<u>1,750,000</u>	<u>2,100,000</u>	
Sub-Total		<u>1,500,000</u>
<u>8,000,000</u>		<u>6,500,000</u>
TOTAL ESTIMATION COST (MB BS)		<u>3,500,000</u>
<u>6,500,000</u>	<u>20,000,000</u>	

Source: Government Bursaries, Nigerian Medical Schools and Author's (2014)

TABLE 3: INTERNSHIP TRAINING AND INDUCTION RELATED COST

Doctor's Direct Private Cost per Person

	TOTAL (N For one
Year	<u>In Year -7</u>
Post MBBS Registration fee with MDCN	200,000
200,000	
Textbook and Additional Reading materials	600,000
600,000	
Accommodation and Feeding expenses	600,000
600,000	
Transport, and Conveyance expenses	400,000
400,000	

Induction – Oath Swearing Ceremony expenses	200,000
200,000	
Salary Income Under-payment (N3m - N1.2m)	1,800,000
1,800,000	
Incidental expenses	<u>600,000</u>
<u>600,000</u>	
=	<u>3,000,000</u>
<u>3,000,000</u>	
Public Costs -Indirect public costs	1,200,000
1,200,000	
SUB-TOTAL	<u>4,000,000</u>
<u>4,000,000</u>	
TOTAL ESTIMATION COST	=
<u>24,000,000</u>	<u>24,000,000</u>

Source: Author's Research Compilation (2014)

Table 4: TOTAL EXPENSES FOR THE 6 YEARS RESIDENCY PROGRAMME

Total Annual Expenditure - Residency Programme @ N5m for 6 Years = N30 m

APPENDIX 5

Table 5.1: WORKINGS: MODEL NUMBER (I) TOTAL COST AND EARNINGS

WORKINGS: TEST NO. (1) CALCULATION OF BREAK-EVEN LEVEL

Post-Registration Start-Up Salary of Resident Doctors
N3.60m

Post-Residency Start-Up Salary of Resident Doctors
N9.60m

Estimated total investment (Basic and Residency Studies)
N54.0m

Total Gross earnings in 10.5 years (Annual average N5m Plus)
N54.0m

Pay Back Period (in Years)

10.5Yrs

WORKINGS: MODEL NUMBER (2) TOTAL SUBSIDY VERSUS EARNINGS

Total Estimated Cost for MB BS and Residency Programme in 13 Years

= N54.00m

Less: Total Expenditures borne by a Participant

= (N27.00m)

Total Government Subsidy to ConsultantDoctors Education

= **N27.00m**

Total Gross Earnings in 13 Years

=

N78.80m

Total Cost Outlays in 13 Years for basic and Residency Studies

= N54.00m

Total Government Subsidy to ConsultantDoctors Education

=

(N27.00m)

But, the BEP level is where Inflow = Outflow: $78.8m / 13 \times 10.5 =$

$N54.00m - N27m / X =$ in the 7.5 Years Therefore, 7,5 Years or 8

Years (approx) is the point where total cost outlay for the entire

programmes of study is fully offsetted by the gross earnings.

WORKINGS: Test NO. (4) CALCULATIONS OF NET TERMINAL VALUE

(Rate of Return to Education Measurement (with interest, annual increment))

Start-Up Pay Point (Life-long):

(A)

Start-up Salary

N3.60m

Post-Residency

Start-Up Salary of Resident Doctors

N9.60m

Life-Cycle income

N874.00m

Less: Living Expenses

N624.00m

Net Savings @ 25%

N250.00m

Less Estimated total investment

N 54.00m

Net Total Income Value

N196.00m

Net Terminal Actuarial Value

N135.00m

Rate of private return to Outlay

17%

Gross Terminal Value is the life-cycle income earnings less

Outlay = N874.00m

TABLE 5.2: DOCTORS' POST-QUALIFYING EARNINGS IN FIRST 10 YRS

Proxy Names Age Employment Current Position Post NYSC
Annual Salary

Qualified Consultants Doctors in Public Service mean salary is
N9.60 m (pa)

**BOARD STRUCTURE, OWNERSHIP STRUCTURE AND
FINANCIAL PERFORMANCE OF MANUFACTURING FIRMS IN
NIGERIA – Enakirerhi, L. I.**

Department of Accounting, Banking and Finance

Faculty of Management Sciences

Delta State University

Nigeria

enakirerhil@yahoo.com, +2348039485777

Board Structure, Ownership Structure and Financial Performance of Manufacturing Firms in Nigeria

Abstract

The paper examined board structure, ownership structure and financial performance of manufacturing firms in Nigeria. The study examined forty (40) manufacturing related firms listed on the Nigerian Stock Exchange, from 2009 to 2013. The performance of firms was proxy by return on assets (ROA) and Earnings Per Share (EPS) while the board structure were proxy by Board Size (BS), Board Independence (BI) and ownership structure by Ownership Concentration (OC) and Directors' Interest (DI). The results of the panel data Random Effect Model (REM) showed that Board Size, Board Independence, Ownership Concentration and inside ownership (directors' interest) showed positive effects on the performance of firm. However, when performance was proxy by EPS, the coefficient of OC becomes statistically significant at 1% level. By implication, firms with larger board size and greater independence are likely to perform better and as such these should be encouraged. Also, performance is influenced positively when ownership is concentrated around few people. This might highlight the likely role of institutional investors who are considered more knowledgeable in financial affairs in Nigeria and thus will likely shape Nigeria investment future. Finally, when directors have ownership stake in the firm, it influenced their ability to effectively monitor the operations of managers to yield better performance. As such, directors' ownership should be encouraged as there is a moral obligation to effectively monitor what one owes. Regulatory authorities should emphasize the needs for directors of firms to own a substantial percentage of the firms' share. A change of the code of corporate governance to this effect will eventually charge directors with moral, legal and contractual obligation to effectively monitor the opportunistic behavior of firms' managers.

Key Words: board structure, ownership structure, NSE, Performance, Agency Theory

Introduction

The issue of corporate governance continues to be of importance to academic, business and government. This is probably due to the importance of firms in the development of any economy and the need to safeguard these firms which play a pivotal role in the economy from collapse. Corporate governance is one of the most important areas, widely studied by researchers for increased value relevance. Jatinder (2014) defined corporate governance as a mechanism to structure, operate and control a company with the objective of achieving a long-term strategic goal of safeguarding the interests of shareholders and other stakeholders. As such a growing number of researchers such as Aamir and Sajid (2012), Adeusi et al (2013) and Mohammed and Kazi (2013) have linked strong corporate governance with performance. Perhaps the failure of firms such as Polly Peck in the 1980s and Enron in 2001 have led to increased discuss on the issue of strong corporate governance and have resulted in regulators tightening corporate governance codes. In this line, the US corporate scandals of the early 2000s led to the passage of the Sarbane Oxsley Law (2002) with other nations following suits. Corporate governance enables corporations to attain their corporate objectives and to protect the rights of shareholder (Khaliq and Muhammad, 2013). However, the effectiveness of corporate governance is represented by the structures and process lay down by a corporate entity to minimize the extent of agency problem as a result of separation between ownership and control (Velnampy, 2013).

The focus is how to manage firms' resources in the best interest of shareholders since control differs from ownership. Agency problem pitches the managers, shareholders and debt-holders on opinion diverse, making the issue more challenging and intriguing. By opportunistic behavior, managers will not always act in the best interest of shareholders necessitating a setting up monitoring mechanism (Board of Directors). Directors on the other hand are saddled with responsibility of monitoring managers but are hampered due to self interests and opinion diverse that exist among individuals. The question arises how this agency problem can be reduced or possibly eliminated. Perhaps, a possible solution is to make the directors' interests align with that of the shareholders through share purchase and by vesting controlling power in the hands of few knowledgeable individuals or organization. On this background, this study examines board structure, ownership structure and financial performance of Nigerian Manufacturing firms. Although, the variables are limited to board size, board independence, ownership concentration and directors' interest (inside ownership), the findings of the research is intriguing and lend credence to the assertion that few knowledgeable people who owns majority of the firms will propel and compel managers to better performance.

1.1 Aims and Objectives of the Study

The main aim of the study is to examine board structure, ownership structure and financial performance of Nigerian Manufacturing firms. Specifically, the following objectives are examined:

1. To determine the effect of size of board of directors on firms performance
2. To determine the effect of board independent on firms performance
3. To determine the effect of ownership concentration on firms performance
4. To determine the effect of director`s shareholding interest (inside ownership) on firms performance

1.2 Organization of the study

The remainder of the study is organized as follows: Section two discusses the various relevant and recent literature on the issue of corporate governance and various hypotheses and theories are outlined in this section. Section three outlines the research methodology adopted in this study and the various sources of data while the fourth section is dedicated to analysis

of data and the discussion of results. The last section draws conclusion based on discussed results.

Literature Review

2.1 Corporate Governance

Yinusa and Babalola (2012) asserted that corporate governance has succeeded in attracting a good deal of public interest because it is a tool for socio-economic development. The Cadbury Report (1992) defined corporate governance as a system through which a firm is controlled, directed and governed. Objectively, firms are controlled to ensure accountability to the owners. As such, corporate governance thus means a set of internal and external mechanism set up to ensure that a firm is acting in a socially acceptable manner in the society it operates and to ensure that a firm is accountable (morally and otherwise) to its various stakeholders. The board of directors have been a focal point in the accountability of firms and Onakoya, Fasanya and Ofoegbu (2014) noted that considerable research have focused on the need to have outside directors in the board. Since Latief, Raza and Gillani (2014) noted that corporate governance exists to give relief to stakeholders and prompt firms to better performance, it could be said that firm's performance is conditioned (though not alone) on good corporate governance practice. Some authors such as Chaghadari (2011), Kaur (2014), Velnampy (2013) and Raihan and Hoque (2013) have contributed substantially to this discuss by empirically investigating the impact of corporate governance on firms' performance. Also, various theories affect the development of corporate governance over the years. These are agency theory, transaction cost theory, stewardship theory and stakeholder theory with Waweru and Riro (2013) asserting that agency theory is the most prominent and influential of them.

2.2 Agency Theory

This theory was first proposed by Jensen and Meckling in 1976 and has helped to shape recent codes of practice in governance. The theory is based on asymmetry of information between managers and shareholders which give rise to conflict of interest between managers and stakeholders. As applied to corporate governance, the theory suggests a fundamental problem for absent or distant owners/shareholders who employ professional executives to act on their behalf. These executives as agents are expected to

act in the best interest of the shareholders but this is not usually the case as they serve their own interests necessitating the setting up of monitoring mechanism of check and balances to checkmate the activities of professional managers (Waweru and Riro, 2013 and Jensen and Meckling, 1976). A crucial monitoring mechanism based on agency perspective also entails the separation of the role of CEO from chairman of the board (William et al. 2003). Adeusi et al (2013) cited that studies suggest that firms tend to have poor performance when they have greater agency problems and these allow managers to generate personal benefits that serve their own interest instead of those of the stockholders. Hence, an efficient governance structure is believed to be one of the most important means by which such agency problems may be alleviated (Bino and Romar, 2010). Agency theory assumptions have, nevertheless, been highly influential in shaping the reform of corporate governance systems. Agency theory establishes the importance of incentives and self-interest in organizational thinking. Agency theory reminds us that much of organizational life, whether we like it or not, is based on self-interest.

2.3 Empirical Evidence and Hypotheses Formation

This section focuses on empirical evidence on corporate governance and firm performance. The following variables are discussed: Board Size, Board Composition, Insider Ownership, and Ownership Concentration.

2.3.1 Size of the Board of Directors

Board size has been one of the significant factors used in measuring the level of corporate governance in many literatures (Swamy 2011). Therefore selecting the size of the board of directors should be of utmost care based on compatibility, convenience and availability to attend meetings. Different code of corporate governance around the world set the minimum number of board members but no maximum is stipulated. In Nigeria, the Code of Corporate Governance for Public Companies in Nigeria (2011) set the minimum to be five (5) members but left the maximum to the decision of the firm based on their needs. According to Lipton and Lorsch (1992), large boards are less effective due to lack of coordination, difficulty in management and thus breeding negative impact on performance. Some authors, such as Eisenberg et al. (1998) and Cheema and Din (2013) have found board size to negatively impact performance. Other authors have found a positive relationship between board size and performance and explained that large boards are able to share work load among members

which ultimately results in better performance. Among these are Onakoya, Fasanya and Ofoegbu (2014), Tarak and Manna (2013) and Kiel and Nicholson (2003). Other authors favour smaller board size and argued that high degree of coordination and efficiency in smaller board leads to better performance and have found a positive impact of small board size on performance. Among these authors are Sanda, Makaila and Garba (2005). Although, the direction of relationship between board size and performance remains unclear especially as regards manufacturing firms in Nigeria, it is our opinion that board size should positively impact performance. Thus:

H0: Board size has a negative effect on the financial performance of firms

H1: Board size has a positive effect on the financial performance of firms

2.3.2 Board Independence

With increased competition, effectiveness of corporate governance for protecting stakeholders' interest has become important, and board independence and board meeting are two important elements of corporate governance (Tarak, 2013). Chaghadari (2011) and Abdullah (2004) explained that the independence of the board of director is very significant to the performance of the organization while Muhammed *et al* (2013) showed that the independence of board has a significant impact on the financial performance of the listed companies of Pakistan. Fama and Jensen (1983) explained independence directors are expected to represent the interests of shareholders by mitigating agency problems between management and shareholders. This careful thought may lead one to assert that firms perform better when they are being monitored by a board dominated by independent outside directors. According to Onakoya, Fasanya and Ofoegbu (2014), a considerable research has focused on the importance of the composition of the board of directors, especially outside directors and that outside directors represents shareholders and mitigates the agency problem. Board independence is undoubtedly one of the influential variables of corporate governance. Onakoya, Fasanya and Ofoegbu (2014), Kaur (2014) and Velnampy (2013) have established empirical relationship between board independence and performance. The board independence is measured by the number of non-executive directors to the total number of directors in the board. Thus, we hypothesize:

H0: Board independence has a negative relationship with performance

H1: Board independence has a positive relationship with performance

2.3.3 Ownership Concentration

This governance mechanism refers to the proportion of firms' share owned by a given number of the largest shareholders. Berle and Means (1932) explained forth that ownership dispersion implies management is distinguished from ownership. Jensen and Meckling (1975) emphasized that this contribute to agency problems between managers and shareholders or shareholders and debt-holders. On the other hand, Morck, Shleifer and Vishny (1988) detected the phenomenon of ownership concentration. La Porta et al. (1999) and Claessens et al. (2002) usher in the conception of ultimate controller. They defined firms' ownership as voting rights, unearthing that many controlling shareholders of listed firms predominate by means of pyramid structure and cross holding which could result in central agency problem. The question remains if these controlling shareholders could pilot the firms towards better performance. The firms with lower ownership concentration are less profitable and the firms with disparity between ownership rights and control rights are also showing less profitability (Jatinder, 2014). A high concentration of share tends to create more pressure on managers to behave in ways that are value maximizing. In support of the argument, Gorton and Schriind (1996) and Shleifer and Vishny (1997) suggested an increase in concentration will be associated with an increase in firm value but that beyond a certain level of concentration, the relationship might be negative.

According to Conny, Taylan, and Stefan (2012) the relationship between ownership concentration and firm performance has been the topic of many studies. In many cases, these studies yield conflicting results. For instance, Morck, Nakawum and Shivdasani (2000), Thomsen and Pederson (2000) and Gedajlovic and Shapiro (2002) documented a positive relationship between ownership concentration and firm performance, whereas Leech and Leahy (1991) to some degree, Classens et al (2002) find that ownership concentration is negatively related to firm performance. Other studies like McConnell and Servaes, (1990) and De Miguel et al (2004) found evidence of a nonlinear relationship between ownership concentration and firm performance. The lack of accordance among studies is a source of

uncertainty and requires further clarifying studies. Agrawal and Mandelkern (1990) explained that the firm performance improves when ownership and managerial interest are merged through concentration of ownership. The reason is that when major shareholdings are acquired, control cannot be disputed and resulting concentration of ownership might lower or completely eliminate agency costs. In this vein, Lee-Hsien, Chien-Ting and Chen (2013) found institutional ownership (investors) positively impacted performance of Chinese firms. This suggests that institutional ownership seems to play an effective monitoring role for Chinese firms. In this study, ownership concentration is represented by the percentage of shares owned by the largest shareholding group. Thus, the hypothesis tested is:

H0: Ownership Concentration has a negative relationship with performance of firms

H1: Ownership concentration has a positive relationship with performance of firms

2.3.4 Insider Ownership (Directors' Interest)

Insider refers to employees, directors and managers who enjoy information advantage about the firm over the market. McConnell and Servaes (1990) suggest that insider ownership may also perform a monitoring role for the firm. It follows that as the share ownership of insiders increase and that their interests are more aligned with those of shareholders, the cost of monitoring tends to be lowered. Several researchers (De Angelo and De Angelo, 1985; McConnell and Servaes, 1990) have undertaken research on this aspect reporting conflicting results. In particular, McConnell and Servaes (1990) find a significant curvilinear relationship between insider ownership and firm performance. The study of Lee-Hsien, Chien-Ting and Chen (2013) of Chinese firms showed that both insiders and institutional ownerships are positively related to firms' performance, a consistent results with prior studies of Hartzell and Starks (2003) and Cornett et al (2007). This suggests that an increase in insider ownership helps to lower potential conflict of interest between manager and shareholders and thereby increases firm value. In this study, inside ownership is represented by the percentage of shares owned by directors (directors' interest) and the following hypothesis is tested:

H0: Directors' interest has a negative relationship with performance of firms

H1: Directors interest has a positive relationship with performance of firms

Research Method

3.1 Sources of Data and Sample

The study uses the secondary data of firms listed on the floor of the Nigerian Stock Exchange (NSE) for a period of five (5) years. The financial information (variables of interest) of firms were collected from the annual report of forty (40) manufacturing firms over five years, 2009 to 2013 giving rise to 200 firm year observations. The forty (40) firms were selected based on information availability. The data were sourced from companies' website, annual reports and www.africanfinancials.com.

3.2 Method of Data Analysis

The study uses quantitative approach as the main tools of data analysis due to the nature of the research. As such data for 40 firms over 5 years were pooled to form a pooled data. The Ordinary Least Square (OLS) estimate was applied to determine the effect of the independent variables on the dependent variable (see table 4.1). However, the joint significant test (F-Test) and Breusch-Pagan Test rejected the OLS estimate in favour of a panel estimate, indicating that OLS may not yield Best Linear Unbiased Estimate (BLUE) (see table 3.2). The choice was to determine if the fixed effect model (FEM) or random effect model (REM) would be appropriate and would yield BLUE. Using the Hausman Test, the results rejected the FEM in favour of REM (see table 3.2). Hence, the results of the analysis are interpreted based on REM estimate. The use of regression and quantitative approach is in line with previous work of Tarak and Manna (2013), Swamy (2011) and Ntim and Osei (2011). The study regression model is stipulated below

Performance = f (BS, BI, OC, DI)

Thus:

$$FP = \beta_0 + \beta_1 BS + \beta_2 BI + \beta_3 OC + \beta_4 DI + \varepsilon$$

Where:

FP = Financial Performance = ROA and EPS

Return on total Assets (ROA) = operating profit divided by the total assets of firms

EPS = Earnings per Share (k) as calculated by the firm

Board Size (BS) = Total number of directors in the board

Board Independence (BI) = proportion of non-executive directors to total number of directors

Ownership Concentration (OC) = Percentage of shares own by the largest shareholders

Directors interests or Inside Ownership (DI) = percentage of shares own by firms' directors

Table 3.2 Panel Diagnostics Tests

Models	Joint Significant Test	Breusch-Pagan Test	Hausman Test
	Chi-Square (p-value)	Chi Square (P-value)	Chi Square (P-value)
ROA	2.19718 (Pooled OLS) (0.0004***) Rejected	12.2249 (Pooled OLS) (0.0005***) Rejected	3.69272 (FEM) (0.4492) Rejected
EPS	20.692 (Pooled OLS) (0.0000***) Rejected	241.464 (Pooled OLS) (0.0000***) Rejected	6.9696 (FEM) (0.1375) Rejected

Source: Author's computation from output of regression

4.0 Analysis and Discussion of Results

Table 4.1: Pooled OLS Regression Results

Independent Variables	Return on Assets (ROA)	
	Regression Coefficients	P-value
Constant	-0.2009	0.0457 **
Board Size (BS)	0.0921	0.0245 **
Board Independence (BI)	0.1048	0.0402 **
Ownership Concentration (OC)	0.1015	0.0302 **
Directors' Interests (DI)	0.0502	0.2878
F(4, 195)	3.8673	0.0048 ***
Sum squared resid	4.1051	

S.E. of regression	0.1451	
R-squared	0.0735	
Adjusted R-squared	0.0545	
Durbin-Watson	1.0581	

Source: Author's computation extracted from regression output

*** Significant at 0.05 level of significance*

Table 4.2: Random Effect Model (REM) Regression Results

Independent Variables	The Dependent Variable (Financial Performance)	
	Return on Assets-coefficient of Regression (P-value)	Earnings per Share-coefficient of Regression (P-value)
Constant	-0.1430 (0.2394)	-314.599 (0.2945)
Board Size (BS)	0.0750 (0.1246)	56.0976 (0.5973)
Board Independence (BI)	0.0779 (0.2165)	73.9680 (0.6201)
Ownership Concentration (OI)	0.1020 (0.1029)	634.378 (0.0065 ***)
Directors' Interest (DI)	0.0249 (0.6676)	38.5572 (0.7774)
Mean dependent var	0.1321	227.8433
Sum squared resid	4.1184	37092802
S.E. of regression	0.1450	435.0276
Within' variance	0.0170	35996.4
Between' variance	0.0079	162342
theta used for quasi-demeaning	0.3434	0.7894

Source: Author's computation extracted from regression output

**** Significant at 0.01 level of significance*

Board Structure and Financial Performance

From table 4.2, board size has a positive impact on the performance of firms measured by the ROA and EPS. This shows that an increase in the number of members in the board leads to better performance of firms in support of the argument and empirical findings of Onakoya, Fasanya and Ofoegbu (2014) and Tarak and Manna (2013). When the size of board is increased by one unit, return on assets increased by 0.08. In terms of EPS, a unit of board members increased EPS by 56k. However, since the board size in this study was not separated into small board and big boards (though the separating line to determine how big is conflicting and a matter of opinion), the research could not validate the argument of Sanda et al (2005) for board coordination and efficiency when the number of board members is reduced. Although the impact of board size was statistically insignificant at 0.05 levels, it should be noted that many factors such as the quality of management, market factors, etc influence the performance of firms but a healthy board helps re-focus and curb the opportunistic behaviors of managers. In this regards, the author did not expect a statistically significant relationship. Furthermore, board independence shows a positive and significant effect on the performance of firms measured by ROA and EPS. Table 4.2 shows that although the explanatory power of the coefficients of regression are 0.08 and 73.97k, greater independence seems to enhance performance. As explained earlier, the statistically insignificant relationship is as a result of influencing factors on performance which are outside board structure. This is confirmed by the R-square of the Pooled OLS estimate, indicating that 93% of factors affecting financial performance are not captured in board structure and ownership structure alone. Board independence has been one of the key components of corporate governance around the world and many corporate governance authorities encourage the board to be as independent as possible. The findings of this paper support the previous findings of Kaur (2014) and Velnampy (2013). However, the agreeable ratio of the number of non-executive directors to the total number of the board is unclear. This should be a new focus of research in order to establish a universal and acceptable number.

Ownership Structure and Financial Performance

The ownership concentration represented by the percentage of share own by the highest group of shareholders showed a positive relationship

with the performance of firm measured by the ROA. However, when the performance variable is proxy by the EPS, the relationship becomes statistically significant at 1% level. This indicates that when ownership is concentrated around a few bloc of persons, the firm performs better. Concentration of ownership improved ROA by 10% and the EPS by 634k, indicating significant reduction in agency problem. This is because, according to Jensen and Meckling (1975), agency problem is reduced due to improved relationship between managers and the few shareholders that control the organization. Aligning the interest of various parties resulted in improved performance. Furthermore, these few individuals usually have expertise in business and because they wield large voting power, they seem to control the firm and prioritized management behavior in line with shareholders expectation. The result supports the works of Morck et al (2000), Thomsen and Pederson (2000) and Gedajlovic and Shapiro (2002). High concentration brings improved information sharing between managers and shareholders and lower agency problem since there is undisputed control of the firm.

Directors serve to control the opportunistic behavior of the manager and there is a moral obligation to improve what someone owns. Thus, directors are encouraged to own share in the firm, aligning their interests with that of the shareholders and hence directing the affairs of management to curb opportunistic behaviour. The result of the analysis shows that inside ownership (DI) positively impact the performance although the coefficient of regression is statistically insignificant. In line with McConnell and Servaes (1990), the results reveal that interest of directors and shareholders align as inside ownership increases. This is because the directors perform a monitoring role because of their ownership stake and the agency cost gradually reduces aligning the managers and the shareholders of the firm. Although the magnitude of the coefficients of regression is low, the direction of effect affirms the strong beliefs that inside ownership could improve firms' performance.

5.0 Conclusion and Recommendation

The study examined board structure, ownership structure and financial performance of Nigerian manufacturing firms. The results showed board size and independence to positively impact the return on assets supporting previous researches. However, the study did not support the argument for or against the efficiency of large or smaller board size and

the extent to which a board could be classified small or large. This is a further area of research. The study is still unclear as to the extent the proportion of non-executive directors to total number of directors would be of advantage to a firm. The ownership structure and directors' interest (inside ownership) showed a positive impact on performance. The implication of this study is that firms with larger board size and greater independence are likely to perform better and as such these should be encouraged. Furthermore, performance is influenced positively when ownership is concentrated around few people. This highlights the role and importance of institutional investors who are considered more knowledgeable in financial affairs in Nigeria and thus will likely shape Nigeria investment future. Already, institutional investors play a significant role in other economies but its role has been low in Nigeria. Finally, when directors have ownership stake in the firm, it influenced their ability to effectively monitor the operations of managers to yield better performance. As such, directors' ownership should be encouraged as there is a moral obligation to effectively monitor what one owes. Regulatory authorities should emphasize the needs for directors of firms to own a substantial percentage of the firms share. A change of the code of corporate governance to this effect will eventually charge directors with moral, legal and contractual obligation to effectively monitor the opportunistic behavior of firms' managers.

Reference

- Aamir, K. and Sajid, H.A. (2012) 'Effect of Board Composition on Firm`s Performance: A Case of Pakistani Listed Companies'. *Interdisciplinary Journal of Contemporary Research in Business*, 3, 853-863
- Abdulla, S.N. (2004) 'Board Composition, CEO Duality and Performance Among Malaysian Listed Companies'. *Journal of Corporate Governance*, 4(4), 47-61.
- Adeusi, S.O. et al (2013) 'Corporate Governance and Firm Financial Performance: Do Ownership and Board Size Matter?. *Academic Journal of Interdisciplinary studies* 2, 3-10
- Agrawal, A., and Mandelker, G. (1990) 'Large Shareholders and the Monitoring of Managers: The Case of Antitakeover Charter Amendments'. *Journal of Financial and Quantitative Analysis*. 25, 143-161.

- Bino, A. and Jomma, S. (2010) 'Corporate Governance and Bank Performance: Evidence from Danian Banking industry'. Observation/list/conferences Jan.27.
- Cadbury Committee Report (1992) '*The Financial Aspects of Corporate Governance*'. London : Geeand Co. Ltd
- Chaghadari, M. F. (2011) ' Corporate Governance and Firm Performance.' *International Conference on Sociality and Economics Development IPEDR vol.10*
- Cheema, K. R and Din, M. S. (2013) ' Impact Of Corporate Governance On Performance Of Firms: A Case Study Of Cement Industry In Pakistan.' *Journal of Business and Management Sciences 1 (4), 44-46*
- Claessens, S. (2002) 'Disentangling the Incentive and Entrenchment Effects of Large Shareholders'. *Journal of Finance, 57, 2741-2771.*
- Conny, O., Taylan, M., Stefan, S. (2012) 'Keeping it Real or Keeping it Simple? Ownership Concentration Measures Compared, 1-47.
- Cornett, et al (2007) 'The Impact of Institutional Ownership on Corporate Operating Performance'. *Journal of Banking and Finance, 31, 1771-1794.*
- De Angelo, H, and L. De Angelo (1985) 'Managerial Ownership of Voting Rights; A Study of Public Corporate with Dual Classes of Common Stock'. *Journal of Financial Economics 14, 33-69.*
- De Miguel et al (2004) 'Ownership Structure and Firm Value; New Evidence from Spain'. *Strategic Management Journal 25 (12), 1199-1207.*
- Eisenberg, T., Sundgren, S., and Wells, M. T. (1998) 'Larger board Size and Decreasing Firm Value in Small Firms'. *Journal of Financial Economics, 48(1), 35-54.*
- Fama, E.F., Jenson, M.C (1983) 'Separation of Ownership and Control'. *Journal of Law and Economics 26, 301-325.*
- Gendajlovic, E., Shapiro, D.M. (2002) 'Ownership Structure and Firm Profitability in Japan'. *Academy of Management Journal, 45(2), 5655-5750.*
- Gorton, G. and Schriind F. (1996) 'Universal Banking and Performance of German Firms'. Working paper 5453, National Bureau of Economic Research Cambridge Massachusettes U.S.A.
- Hartzell, J.C. and Starks, L.T. (2003) 'Institutional Investors and Executive Compensation'. *Journal Finance, 58(6), 2351-2374.*
- Jatinder, K. (2014) 'Corporate Governance and Financial Performance'. *Asian Journal of Multidisciplinary studies 2, 91-96.*

- Jensen M. C., Meckling W.H., (1976) 'Theory of the Firm: Managerial Behaviour, Agency Costs, and Ownership Structure'. *Journal of Financial Economics* 3 (4), 305– 360
- Kaur, J. (2014) 'Corporate Governance and Financial Performance: A Case of Indian Banking Industry.' *Asian Journal of Multidisciplinary Studies* 2(2), 91 – 96
- Khaliq Ur, R.C., and Muhammad, S.D. (2013) 'Impact of Corporate Governance on Performance of Firms: A Case Study of Cement Industry in Pakistan'. *Journal of Business and Management Sciences*, 1(4), 44-46.
- Kiel, G. C. and Nicholson, G. J. (2003) 'Board Composition and Corporate Performance: How the Australian Experience Informs Contrasting Theories of Corporate Governance'. *Corporate Governance: An International Review* 11(3), 189-205
- La Porta, R., Lopez-de-Silanes, F., and Shleifer, A. (1999) 'Corporate Ownership Around the World'. *Journal of Finance*, 54, 471-517.
- Latief, R, Raza, H.S., and Gillani, S. A. H (2014) 'Impact of Corporate Governance on Performance of Privatized Firms; Evidence from Non-Financial Sector of Pakistan.' *Middle-East J. Sci. Res.*, 19 (3), 360-366
- Leech, O., Leahy, J. (1991) 'Ownership Structure, Control type Classifications and the Performance of Large British Companies'. *Economic Journal*, 101 (409), 1418-1437
- Lee-Hsien, P., Chien-Ting, L., Chen, K.C. (2013) 'Corporate governance and Firm performance'. *The International Journal of finance*, 25 (1), 7581-7605.
- Lipton, M. and J. W. Lorsch (1992) 'A Modest Proposal for Improved Corporate Governance'. *Business Lawyer*, 48(1), 59-77.
- McConnell, J.J., and Servaes, H. (1990) 'Additional Evidence on Equity Ownership and Corporate Value'. *Journal of Financial Economics*, 27(2), 595-612.
- Mohammed, I.H. et al (2013) 'An International Review of Impact of Corporate Governance Variables on Firm Performance: A Comparison between Pakistan and Some other Countries'. *International Journal of Innovative and Applied Finance*, 1-16.
- Mohammed, Z.R., and Kazi, E.H. (2013) 'Impact of Corporate Governance Practices on performance in some Selected Private Commercial Banks in Bangladesh'. *Actual problem of Economics*, 11(149), 484-493
- Morck, R., Nakawum, M., Shivdasani, A. (2000) 'Banks, Ownership and Firm's Value in Japan'. *Journal of Business*, 73(3), 539-567.

- Morck, R., Shleifer, A., and Vishny, R. (1988) 'Management Ownership and Market Valuation: An Empirical Analysis'. *Journal of Financial Economic*, 20, 293-315.
- Ntim, C. G. and Osei, K. A. (2011) 'The Impact of Corporate Board Meetings on Corporate Performance in South Africa'. *African Review of Economics and Finance*, 2 (2), 83-103
- Onakoya, A. B. O., Fasanya, I. O., and Ofoegbu, D. I. (2014) 'Corporate Governance as Correlate for Firm Performance: A Pooled OLS Investigation of Selected Nigerian Banks'. *IUP Journal of Corporate Governance* 13 (1), 7-18
- Sanda, A.U., Makaila A.S and Garba T. (2005) 'Corporate Governance Mechanisms and Firms Financial Performance in Nigeria'. AERC Research Paper , 149.
- Sarbanes-Oxley Act (SOX). (2002) '*Public Law No. 107-204*'. GPO: Washington, DC
- Securities and Exchange Commission (2011) '*Code of Corporate Governance for Public Companies in Nigeria*'. Lagos
- Shleifer, A., and R.W. Vishny (1997) 'A Survey of Corporate Governance'. *Journal of Financial Economics* 52 (2), 737-783.
- Swamy, V. (2011) 'Corporate Governance and Firm Performance in Unlisted Family Owned Firms'. *International Journal of Business Insights & Transformation* 4 (2), 37-52
- Tarak, N. S. and Manna, A. (2013) 'Impact of Board Composition and Board Meeting on Firms' Performance: A Study of Selected Indian Companies'. *Vilakshan: The XIMB Journal of Management* 10 (2), 99-112
- Te-Kuang Chou (2013) 'Insider Ownership and Firm Performance in Taiwan'. Proceedings of 8th Annual London Business Research Conference Imperial College, London, 1-12.
- Thomsen, S., Pederson, T. (2000) 'Ownership Structure and Economic Performance in the Largest European Countries'. *Strategic Management Journal* 21(6), 650-705
- Velampy, T. (2013) 'Corporate Governance and Firm Performance: A Study OF Sri Lankan Manufacturing Companies'. *Journal of Economics and Sustainable Development* 4 (3), 228 – 236
- Waweru, N. M. And Riro, G. K. (2013) 'Corporate Governance, Firm Characteristics and Earnings Management In An Emerging Economy'. *Journal of Applied Management Accounting Research* 11 (1), 43-64

- William, Q.J., Naoumova, I., and Kouizevol, N. (2003) 'Corporate Governance and Firm Performance in Russia: an Empirical Study'. *Journal of World Business*, 38: 385-396.
- Yinusa, O.G. and Babalola, Y.A. (2012) 'The impact of corporate governance on capital structure decision of Nigeria firms'. *Journal in organizational psychology and educational studies*, 1(2) 121-128

**MILITATING EFFECT OF INVENTORY MANAGEMENT AND
CONTROL IN THE MANUFACTURING INDUSTRY: A CASE
STUDY OF CLASSIC BEVERGES NIGERIA LIMITED LAGOS –
Onyebuenyi, F. E.**

School of Management Sciences
National Open University of Nigeria
erimmafaith@yahoo.com
fnnanna@noun.edu.ng
+2348038919442

MILITATING EFFECT OF INVENTORY MANAGEMENT AND CONTROL IN THE MANUFACTURING INDUSTRY: A CASE STUDY OF CLASSIC BEVERGES NIGERIA LIMITED LAGOS

ABSTRACT

Industries incur a lot of cost in keeping inventory. In order to achieve the goals of the organization, proper and effective inventory management and control is needed. They do this through gathering and holding of raw materials for processing, work-in-progress and finished goods held for sale. This research is aimed at investigating the effect of inventory management and control in the manufacturing industry. The study also focused on how manufacturing organization perform and carry out their inventory management and control using Classic Beverage Nigeria Limited as a case study. In carrying out the investigation, a number of questions were drawn up. The study shall explore the use of description and analytical tools where both primary and secondary data were employed. Information necessary to determine the effectiveness of the inventory management and control and the problems involved were gathered, analyzed and summarized. The inventory and control department no doubt is the integral part of any manufacturing firm since they are charge with the responsibility of making sure that raw material are store, production is in progress and finished goods are stored till they are needed for sale. A clear observation from this project work reveals that inventories represent a significant portion of most firms' assets and accordingly require substantial investments. Inadequate inventory management can cripple a manufacturing industry since inventory on which huge funds are committed constitutes the core of its operation. It was recommended that The Economic Order Quantity (EOQ) model or techniques should be fully adopted by Classic Beverages Nigeria Limited in order to improve on its present systems of inventory management and control. This model minimizes total holding cost and total ordering cost. It is the optimal level of inventory.

Key Words: Raw Materials, Work-in-Progress, Finished Goods, Lead or Procurement Time, Stock-Out, Buffer Stock or Minimum Stock or Safety Stock, Re-order Level, Re-order Quantity.

INTRODUCTION

Inventory management and control has been the key to the success of most manufacturing firms and the cause of failure of many others. To this end, good management set intelligent policies, established guideline for inventory levels and ensure that appropriate control systems are put in place and functioning properly.

Stock management in the manufacturing sector has assumed an important role because of its relationship to production. Its effects on sale and profit maximization and cost minimization in a company cannot be over emphasized. However for a proper understanding of the effect of inventory management and control in the manufacturing industry, we need to consider the concepts of inventory and management.

According to Lucey (1988) inventory may be define as materials held in storage for later use or sales. Inventory may take the form of raw materials held for processing, goods in the process of manufacture and finished good held for sales. In other words, inventory is the quantity of goods in stock. Management on the other hand could be defined as the proper planning and control of resource including its utilization and allocation- Honeyren (1970).

Generally, from the above definitions, stock management is the proper planning and control of inventories including utilization and allocation to production and the aftermath of such management decision making. For management to be able to manage stock successfully there should be a proper standard for evaluating stock. These standards could be referred to as the planning and control of inventory by management.

However, it will be important if we know what planning and control are in relation to stock management and the different methods to be adopted by management in planning and controlling its inventories.

In 1988, according to Lucey, planning summaries management's expectations of the future objectives to be obtained while control is the comparison of actual performance with the original plans or alternatively a revision of the plans when they no longer become feasible.

In objectively evaluating how stock management could be planned in Classic Beverages Nigeria Limited, the planning processes should answer such question what does the company want? When and how are the objectives to

be accomplished? The control process on the other hand should enable management to assess whether or not the objectives included in the plan are likely to be achieved.

Generally, inventory control methods have one goal that might be expressed in two ways.

- (I) To establish and maintain the optimal level of investment in all stock from raw material to finished goods. However when establishing optimum stock levels, it is necessary to ensure that sufficient stocks are maintained so that production requirements and demands are met and,
- (II) To ensure that excessive stocks are avoided so that necessary funds will not be tied up in stock which could have been used for other profitable purposes?

The two points mentioned above could impact on the company positively or negatively. In Classic Beverages Nigeria Limited, there is a need to maintain an optimum stock level before, during and after production in order not to breakdown the production process and not to suffer out of stock due to lack of finished goods inventory. This is very important to the company since it operates in a competitive market.

Thus, a company must be conscious of the fact that an optimum level of stock is held. The optimum level of stock held by the company at anytime is always determined by market forces of demand and supply.

The foregoing presupposes that firms face a herculean task in the course of resolving the basic inventory management and control problem and its effect on manufacturing industry.

OBJECTIVES

The broad objective of the study is to find out the Militating Effect of Inventory Management and Control in the Manufacturing Industry a case study of Classic Beverages Nigeria Limited, Lagos. Specifically, the study seeks to:

1. Examine the relationships which exist between sales and the level of inventory which the company maintains.
2. Examine the relationship between production and inventory levels

3. Access the extent to which the company complies with the basic economic order quantity (EOQ) model
4. Evaluate the effectiveness of the system control established in relation to inventory.
5. Make recommendation in the light of the findings from the above objectives.

HYPOTHESIS

In the course of this study, the following hypothesis shall be tested, they are stated in their alternative forms

- (i) The raw materials purchased annually by the company is directly related to its company production level.
- (ii) The raw materials purchased annually by the company is directly related to the company sales level.

One of the most important decisions is about the quantity of inventories. Therefore a lot of mathematical models have been developed, which are summarized under the concept of Inventory Control within the scope of Operations Research.

For the stock of a retail market the outflow is induced through customer sales and the replenishment is secured through orders. The stock disposal therefore consists of ordering the right quantity (lot size) at the right time. Less order produces less order costs; but for a higher level of order quantity the storage costs rise. The advantage of a great inventory is that there is a high level of service and most customer requirements can be fulfilled. Real (short term) inventory problems are those, who deal with order costs, storage costs and the service level. Problems of long term inventory control do not belong to this issue, because the order costs are considered global and not for each order. The situation is similar with intermediate storages. This storage is strongly bound to production and we cannot speak of a proper inventory problem. But the results of inventory control theory can be used for the disposal of intermediate storages.

Inventory otherwise known as stock is that segment of current assets on working capital which a business manufactures for sale or buys for resale. The Nigerian accounting standard Board 4" (SAS4)" classified stock to be those items of value held for use or sale by an enterprise and usually comprises raw materials and supplies used I production, work-in-progress and finished goods.

Over the years different definitions have been given to inventory by different authors based on their area of interest. It is on this ground that inventory could be seen in any of the following forms.

Focusing on integrated production, planning and control process, inventory is all of the materials, parts supplies, expenses tools, work-in-progress and finished products recorded in the books of an organization and kept in the store room, warehouses or plan s (Burbridge 1971). Inventory is also seen as merchandised finished products of manufactured and raw materials (Herngren 1970).

Meigs (1987) specifically looking at the retail and wholesale trade in one of their definitions, described inventory as consisting of all goods owned and held for sale in the regular course of business. The above definitions centered essentially on the relevance or significance of inventory to any organization. In general, inventory could be defined as all items purchased or produced within an organization for the purpose of resale or further production. These inventories exist in the form of tools, supplies, equipment, consumables to mention but a few.

METHODOLOGY

In the course of carrying out this research, the primary and secondary sources of data collection shall be adopted.

The study shall explore the use of description and analytical tools. However, more emphasis will be placed on the analytical tool because of its predictive ability. Therefore, the analysis shall incorporate the use of correlation analysis.

Primary source of data collection is the process of obtaining information from the original sources. Information shall be gotten from the financial statement published by the company for a period of five years. However, the use of

structured questionnaire shall be employed to elicit responses. Oral interview shall be employed to obtain information concerning the organization and the secondary sources will be gotten from Journal, Internet, Textbooks, Dictionaries and unpublished works of some authors.

In research work, data collection and analysis play a vital role in order to arrive at a meaningful conclusion. Methodology is the specification of procedures for collecting and analyzing data necessary to help suggest solutions or solve the problems at hand. In other words, research methodology conveys some of the processes involved in carrying out an investigation in order to discover new fact and documentation of some. (E.J. Ofason).

Research Design and Sources of Data.

For the successful conduct of this research work, data were gathered from various sources. For a clearer picture, data were grouped into primary and secondary sources.

The data were gathered from personal interview and the questionnaire administered to the company's staff.

The secondary sources of data were from the records of various departments in Classic Beverages Nigeria Limited. Other secondary sources of data includes journals, lectures/ speeches delivered by eminent lecturer and unpublished work of some authors. Similarly, internet was a very good source.

In addition, observation techniques were adopted to complement other research methods.

Study Population and Determination of Sample Size using the Departments

Classic Beverages Nigeria Limited (CBNL) was incorporated in Nigeria in the year 2000. Since it began its operations, CBNL never relented in its commitment to supplying first class soft drinks to Nigerians.

Classic Beverages Nigeria Limited, one of the leading players in the carbonated soft drink sector of the market and the first company to produce soft drink in PET bottles has its registered office in Amuwo-Odofin Industrial Estate, Mile 2, Lagos, Nigeria.

Its flagship brand, La Casera Apple Flavour has built and maintained a positive reputation as one of the leading brands, among consumer soft drink choices, experiencing strong demand and visibility. La Casera is available in Apple, Cream Soda, Classic Cocktail and Spanish Pear Flavour. The company manufactures and distributes its products across the country.

Since its inception, CBNL has built an effective business relationship with its trade partners by helping them to make profit whilst also rewarding their efforts.

As part of its goods to connect with its consumers and add value to the environment in which it operates, the company has been in the frontline of supporting beauty pageants in Nigeria since 2007, by crowning their brand ambassador known as Miss La Casera. It also utilizes the platform as a Classic Beverages Nigeria Limited Corporate Social Responsibility (CSR) Vehicle to reach out to the less privileged and the needy in the society.

Classic Beverages Nigeria Limited has contributed and it's still contributing to the Nigerian economy in so many ways. Apart from providing direct employment for hundreds of Nigerians, it creates employment for transporters and suppliers of raw materials. It also generates internal revenue to the government through the payment of tax and excise duties. The workers enjoy a comparative welfare scheme with free medical relationship among the staff and management.

RESULTS

Purchase of Inventory in Classic Beverages of Nigeria Limited

The procurement of raw materials for production of goods is solely the responsibility of the purchasing department. The decision to order is made on the basis of stock level if considered low. The lead time is usually three months.

The General Manager has to approve all purchase requisition before purchases are made. The store-keeper constantly checks on the level of inventory in the store. They check the store cards or bin cards to see if the stock has reached its re-order level.

The production department through production manager sends in their requisition to the purchasing department who then prepares a new requisition form and it is forwarded to the general manager for approval.

The requisition form has columns for item description, quantity required, estimated unit price and estimated value, and name of person who prepared the requisition. It takes 40-90 days for stock to arrive after an order has been placed from overseas.

Receiving and Storage of Inventory in Classic Beverages of Nigeria Limited.

The company purchases its inventory from local and overseas. In case of local purchases, goods are received directly from the suppliers by the store-keepers in store. Whereas, in the case of foreign suppliers, the goods are first cleared by the clearing department (agent) from the port before they are sent to their respective stores.

However, the shipping invoice must be properly checked to see if the shipment correspond with what has been ordered for.

On arrival of the goods at the store, the store keeper carries out routine check to ascertain the quality and quantity of the goods. The result of the check done is compared with what was specified in the way bill and purchased order. The way bill is then signed by the head of clearing department to indicate that the goods have arrived and they are received into the store by the store keeper.

Store cards or bin cards are then opened for each item of stock in the store. Where store cards have previously been opened for a particular item of stock, entries are made to the already existing store card to recognize the addition to that particular item of inventory.

Issuing of Inventory in Classic Beverages of Nigeria Limited

The production manager authorized the use of raw materials inventory from the store. The company uses a requisition from which is called internal requisition or goods issued note. The form contains the following information; items, unit price of items, name of requisitioned, section making the requisition the person who authorized the issue, the person who issue the goods and the person who receives the goods.

After approval of the form by production manager, it's then sent to the store keeper who supplies the required goods. The form is usually prepared in

triplicate; one is retained in the store, one is sent to the account department and computer unit for the update of their records.

Sales of Finished Goods in Classic Beverages Nigeria Limited

The company's policy to sell directly to its customers purchasing large quantities. The company has a large numbers of distributors all over the country. Finished goods are collected by customers from the store on presentation of receipts showing that the goods have been paid for. Similarly, the company engages the use of salesmen/women to sell and distribute the products to its potential customers around the city on retails basis.

The store keeper issue only upon proper authorization and maintain adequate records of inventory movement.

Inventory Valuation Classic Beverages Nigeria Limited

The company adopts the first-in-first-out (FIFO) method of inventory valuation. This method ensures that goods received are issued to production in the same sequence in which they were purchased or acquired. This means that at the end of each accounting period of the company, the closing inventory

(stock)consist of the goods that were last purchased. This method helps the company in its pricing policy.

DATA ANALYSIS

The data shown below are raw materials purchased, production level and the sales of the company's products collected from the company's records. All figures are in tones.

Table 4.1

PURCHASES

Table 4.2
PRODUCTION

FINISHED GOODS	2009	2010	2011	2012	2013	TOTAL
Apple Flavour	3.9	4.8	6.0	6.6	6.9	28.2
Cream Soda	1.1	1.2	1.5	1.9	2.1	7.8
Total	5.0	6.0	7.5	8.5	9.0	36.0

RAW MATERIALS

	2009	2010	2011	2012	2013	TOTAL
FRIUTS	1.2	1.5	1.7	2.1	2.2	8.7
SUGARS	1.8	2.2	3.0	3.8	4.3	15.1
FLAVOURS	1.0	1.3	1.3	1.1	1.5	6.2
TOTAL	4.0	5.0	6.0	7.0	8.0	30.0

Table 4.3

Sales

PRODUCTS	2009	2010	2011	2012	2013	TOTAL
Apple Flavour	3.5	4.2	5.1	6.1	6.6	25.5
Cream Soda	1.0	1.3	1.4	1.9	1.9	7.5
Total	4.5	5.5	6.5	8.0	8.5	33.0

TESTS FOR HYPOTHESIS AND FINDINGS.

HYPOTHESIS 1:

In testing this hypothesis, if the increase in one variable shows a corresponding increase in the other variable, then both variables are said to have a perfect positive relationship. Conversely, if a decrease in one variable show a corresponding decrease in the other variable, then both variables are said to have a perfect negative relationship.

However, if a change in one variable does not lead to a change in the other variables, then the variables are said to have no relationship at all.

Given the formula for the co-efficient of correlation as

$$R = \frac{nExY - ExEY}{\sqrt{[(nEx^2) - (Ex)^2][(nEY^2) - (EY)^2]}}$$

All figures are in tonnes.

Where;

X = Raw Materials

Y = Production Level

R = correlation co-efficient

n = Scope of study / Number of years

Ex = The sum of values of variables X

Ey = The sum of the values of variables Y

EXY = The sum of values of product X and Y

EX^2 = Sum of squares of values of X

EY^2 = Sum of squares of values of Y

Therefore;

n = 5, Ex = 30, Ey = 36, EXY = 1080, Ex^2 = 900, EY^2 = 1296

$$R = \frac{5 \times 1080 - 30 \times 36}{\sqrt{[(5 \times 900) - 900][(5 \times 1296) - 1296]}}$$

$$R = \frac{5400 - 1080}{\sqrt{[4500 - 900][6480 - 1296]}}$$

$$R = \frac{4320}{\sqrt{3600 \times 5184}}$$

$$R = \frac{4320}{\sqrt{18,662,400}}$$

$$R = \frac{4320}{4320}$$

$$R = 1$$

The computation shows that a relationship exists between the variables X and Y explained above. This is true because the correlation co-efficient has a value of one. Therefore, from the computed result, it shows that there is a perfect positive correlation of (1) one. We accept the null hypothesis which states that the raw material purchased by the company is directed related to the production level. Conclusively, it shows that management of Classic Beverages Nigeria Limited is efficient.

HYPOTHESIS II

This test is used to show if the raw material purchased by the company is related to the sales level as shown in table 4.3

All figures are in tonnes

Where;

X = Raw materials

Y = Sales

R = Co-efficient of correlation

Therefore;

$$n = 5, E_x = 30, E_Y = 33, E_{XY} = 990, E_{x^2} = 900, E_{Y^2} = 1089$$

$$R = \frac{5 \times 990 - 30 \times 33}{\sqrt{[(5 \times 900) - 900][(5 \times 1089) - 1089]}}$$

$$R = \frac{4950 - 990}{\sqrt{[4500 - 900][5445 - 1089]}}$$

$$R = \frac{3960}{\sqrt{3600 \times 4356}}$$

$$R = \frac{3960}{\sqrt{15,681,600}}$$

$$R = \frac{3960}{3960}$$

$$R = 1$$

From the above computation, the correlation coefficient is (1) one, which shows a perfect relationship between variable X (raw materials) and Y (sales).

The decision rule is such that if there is a positive correlation between the variables (X and Y) then we accept the null hypothesis which states that the raw materials purchased by the company is directly related to the company's sales.

Therefore, it shows that Classic Beverages Nigeria Limited is efficient in managing its inventory.

Finally, table 4.1, 4.2, and 4.3 shows a gradual increase in the quantity of raw materials purchased by the company, a potential improvement in production of goods as well as increase in total sales of products from/ since 2009 to 2013 respectively.

Thus, if the above figures are plotted on a linear graph, it would show a straight line, which shows that the rate of increase in raw materials is directly proportional to increase in production sales. This demonstrate to a large extent that the company's inventory management and control system (policy) is very efficient and as a result its helps the company to maximized profit.

SUMMARY

This study has attempted to establish the importance / effects of inventory management and control in Classic Beverages Nigeria Limited in particular and in the manufacturing industries in general.

The following were the findings of the research.

- (a.) The result of the data analysis revealed that the company's (Classic Beverages Nigeria Limited) inventory management and control system is very efficient and as a result, it helps the company to maximized profit.
- (b.) The control measure for materials usage or purchase is that, the user department will raise a materials requisition known as the internal requisition form. This form must be approved or authorized by the officer in charge before the store keeper can release such materials from the warehouse. After the completion of these procedures, copies of the form are sent to the accounts department and warehouse unit for posting into various ledgers. These are then used in updating their various records. Similarly, the same procedure is applicable to sales.
- (c.) The company distributes its major product through its destination centres across the country. It is only on the authorization of a delivery order before the storekeeper can release finished goods from the store.
- (d.) Sells mostly on cash and partly credit to reliable distributors of the company. The company monitors its cash velocity through monthly budgets and impress.
- (e.) The company uses perpetual inventory control system.
- (f.) Raw materials for production and sales of finished products are released on the bases of First-in-first-out (FIFO).
- (g.) The raw materials purchased by the company are directly related to the company production as well as sales level. From the result of the tested hypothesis, one can be convincingly say that the inventory management policy of the company is effective.
- (h.) The stock turn over appear low. This affected the liquidity position of the company. The company takes an average of three months before it can sell its stocks from a particular set of production.

CONCLUSIONS

Generally, the researcher found that there is the need for proper management of inventory in order to maintain good financial position for the company. Good and efficient flow is a yard-stick of measuring money flow in a manufacturing firm/ industry. This to a large extent reflects the company's liquidity position. A clear observation from this project work reveals that inventories represent a significant portion of most firms' assets and accordingly require substantial investments. Inadequate inventory management can cripple a manufacturing industry since inventory on which huge funds are committed constitutes the core of its operation.

Finally, from the result of the hypothesis, it was found that the management of inventory by Classic Beverages Nigeria limited is efficient however; there is the need for improvement.

RECOMMENDATIONS

- (a.) The Economic Order Quantity (EOQ) model or techniques should be fully adopted by Classic Beverages Nigeria Limited in order to improve on its present systems of inventory management and control. This model minimizes total holding cost and total ordering cost. It is the optimal level of inventory.
- (b.) In adopting the principle of Economic Order Quantity, efforts should be geared towards training programmes for staff such as workshops and seminars on inventory management and control.
- (c.) Reduction of stock level. The company should try and reduce its stock level by selling at a reduced rate.

REFERENCES.

Anao, A. R. (1987). Introduction to Financial Accounting. Lagos: Longman Nig.Ltd.

Anyiwe, E.M. (1991). Statistical handbook for Economists and social Scientists. Benin City:
AMA Resources Nig. Ltd.

Bel-Molokwu, J. (2010). Production Management II (ENT 420). Lagos: Noun Open

University of Nigeria Press.

Brockington, R. (1990). Production Management Analysis. London: Garret L.T and Silver M

Budbridge, J.L. (1971). The Principle of Production Control. Macdonald and London: Evans

Ltd.

Cook, J. W and Winkle, G.M. (1976): Auditing, Philosophy and Techniques.

Drury, C. (1985). Management and Cost Accounting. USA: R.J Alford Ltd.

Drecken, P. (1954). The Practice of Management. Harper and Row. New York 3rd Edition

Dryden, P. (1981). Introduction to Management Accounting, Prentice Hill Inc. 6th Edition

Ehunduru, A.C. (1990). Introduction to Research Methods. Benin City: Pegasas Printers.

Garrier, L. T. & Silver, N. (1973). Production Management Analysis. New York: Jovanovich,

413 Inc. 3rd Edition.

Garret, L.T. & Silver, M. (1983). Production Management Analysis MC Graw Hill

Book Company

Homgren, C.T. (1970). Introduction to Management Accounting, Prentice Hall Inc-Eagle

Wood Cliffs 6th Edition

Howard, J. N. & Mark, E.G, (1989). Production and Operations Management.USA:

Bacon Inc. Massachusetts. Chichesrter.

Homgren, C.T. (1970). Introduction to Management Accounting. USA. Prentice hill Inc. 6th

Edition

Hanssman, F. (1962). Operational Research in Production and Inventory Control. New York:

John Wiley and sons

Idehal, S. A. (1999). Operation Research. Ekpoma: Edo State University Press.

Jegade, J. F. (1992). "Stock Control for Cost Control". Nigeria: The Nigerian Accountant.

Oct./Dec. Edition.

Lucey, T. (1988). Cost and Management Accounting 1. USA: D.P. Publication Ltd.

Lucey, T. (1988). Quantitative Techniques, An Instructional Manual. USA: D. P. Publication

Ltd.

Manual.DP Rally (1989). Techniques, Investment Analysis and Portfolio management.

Management Dictionary. McGraw Hill Book Company Nigerian Accounting Standard Board

(NASB) 4th January, 1992 – Nigeria, Statement of Accounting standard (SAS).

Ofason, E.J: Lecture Note on Research Methodology.(Unpublished Materials).

Spiegel, M. R. (1972). Theory and Problem of Statistics, New York: McGraw Hill Book

Company.

Woolf, E. (1979). Auditing Today. London: Prentice Hall Inc. Boston, Houghton Mifflin

Co.

THE IMPACT OF FLEXTIME AND COMPRESSED WORKWEEK ON JOB SCHEDUELING AND PERFORMANCE OF ACCOUNTING AND FINANCE PROFESSIONALS

BY

**OSHADARE SEGUN ANTHONY
DEPARTMENT OF BANKING AND FINANCE
FEDERAL UNIVERSITY OF AGRICULTURE,
ABEOKUTA, OGUN STATE, NIGERIA.**

ABSTRACT

This study provides an insight into how professionals should be properly managed with a view to getting the best from them and creating a balanced work life devoid of issues. Although, the expectation from Accounting and Finance professionals is maximum productive performance, it has been an age-long issue that performance dwindles at periods least expected. This is due to the way jobs are scheduled with attendant issues like high labour turnover, absenteeism, window dressing, stress and deaths. Flexitime and Compressed workweek scheduelling options are expected to address these challenges and correct the traditional job schedule which is the bedrock of the issues. Both Descriptive and inferential statistics ,such as percentages and chi-square were adopted for data analysis. Findings show that all professionals crave for schedueling options which will make them to work at productive capacity. These new schedueling options will among other things produce a balanced professional and personal life, reduce stress and commuting period for employees and ultimately help the employers to monitor the performers of their staffs, while scheduling meetings properly.

Keywords: Finance, Accounting, Professionals, Flexitime, Compressed work week, Performance.

1 INTRODUCTION

Every organizational set-up, either profit making or not, has two groups of people who are the employees and employers. Both constitute the pivot upon which the activities of the organizational revolves. The basic thing that distinguish them, however, is defined in the expectation from the employee, which is simply higher productivity. Productivity, according to Oxford dictionary is defined as a state of being productive and having capacity to produce by industry or workforce standards. It is evaluated quantitatively. In order to have effective evaluation, productivity must have accompanying job schedule of which performance can be termed under or over productivity.

Job-scheduling deals with manners in which job is arranged, and it has its own impact on employees' productivity. In time past the whole world including Nigeria have been used to a single pattern of job scheduling i.e. the 8- hours stretch job schedule which in most cases runs from 8am to 4pm. Also, others use the shift job scheduling. This divided the 24 hours in a day to 8hours each for the employee and run morning, afternoon and evening schedules. What hitherto had been a strict scheduling pattern and process as seen above has in recent years been modified to solve the problem hitherto encountered, (Scott Benson 2003).

2 THE MODIFIED JOB SCHEDULES

In order to achieve this optimal productivity, there is need to properly schedule the working period of the employee. Employees' productivity has been seen to be on the decrease in many companies in spite of available monetary reward and adequate working tools. The reason for exploring new method of scheduling is to tackle the problems that has been occurring and reducing the productivity of these employee's. The solution is found in the use of flextime and compressed workweek job schedules.

According to Beneveiga (1995) "Flextime is a scheduling option /pattern that allow employees within specific parameters to decide when to go to work or work".

Hewitt et al (1994) describes Flextime as a short acronym for flexible work hours which allows employees some discretion over when they arrive at and leave work.

Deborah Epstein Henry (2004) in her implementation of flextime posited that employees have to work a specific number of hours a day in a week but they are free to vary the hour within certain limits. Flex time implementation for such company consist of a common core-working period, usually six hours, with a flexible time surrounding the core and also break time included. The core may be 7AM to 10AM and 1 PM to 4PM including one hour break while the flextime can be between 10AM and 12noon and 4PM to 8PM .All employees are required to be on their jobs during the common core period while they are excused during the flex period based on their plans .Some flextime programs even allow extra hour as to be accumulated.

According to Jules Taylor(1994) Compressed workweeks are alternative work arrangements where a standard workweek is reduced to fewer than five days, and employees make up the full number of hours per-week by working longer hours.

Eileen Canty (1996) while working at W.M Mercer Inc. reviewed major schedules for company and says "Although, compressed workweek is not as popular as flextime, it fills a significant niche in the human resource planning of such Industries as advertising, publishing, educational institutions, manufacturing and financial services. The option is still used and "it's more of a boutique item in the major companies that I've worked with",

A compressed work schedule allows an employee to work a traditional 35-40 hour workweek in less than the traditional number of workdays. Many compressed work schedule options may be negotiated. For example, a full-time employee scheduled for 40 hours per week could work four 10-hour days instead of five 8-hour days. Or, an employee could opt to work 8.9 hours per day, and take one full day off every two weeks (exempt employees only). (Rosemary batt 2003, sladek 2001, mercer 1993, cranes 1987).

A comparative analysis of these job schedules shows that flextime is more favored in various countries that have adopted them while the compressed work is used more for manufacturing companies to avoid downtime periods.

3 CONSTRUCTS OF FLEXTIME AND COMPRESSED WORKWEEK

Purdue University Human Resources services in 2002 gave some beneficial uses of the compressed work week to the employee as including improving

employee morale, commitment and productivity by accommodating management's and the employee's need and or responsibilities.

It also includes undisturbed time to work or increase personal time. In overall, it accommodates employees commuting needs.

3.1 CONSTRUCTS OF FLEXTIME

Flex-time is a work schedule which allows employees to work hours that are not within the standard 8:00 AM to 5:00 PM range, while maintaining a high level of service during the organization's peak operating hours (typically 10:00 AM to 3:00 PM). Employees are expected to work whatever number of hours are required in order to accomplish their duties and may be permitted to set their own schedules. **FIG. 1 DIAGRAMATIC REPRESENTATION OF FLEXTIME SCHEDULE**

CORE TIME	FLEX TIME	BREAK PERIOD	CORE TIME	FLEX TIME
7-10AM	10-12NOON	12-1PM	1-4PM	4-6PM
				6-8PM

ADVANTAGES OF FLEXTIME

Considering flextime shows positive implications, which are;

- ❖ Reduced absenteeism
- ❖ Reduced overtime expenses
- ❖ A lessening in hostility towards management
- ❖ Elimination of tardiness
- ❖ Increased autonomy and responsibility for employees that will Increase employee job satisfaction

The reason for flex time having positive implication is that employee can schedule their works hours to meet with personal demands thus reducing tardiness and hurry attitude to their work and avoiding absence due to the flexibility in their work schedules. This makes them to adjust their work activities to these hours in which they are individually more productive.

3.2 CONSTRUCTS OF COMPRESSED WORK WEEK

The compressed work week is a schedule method in which workers accumulate the total hours expected of him /her to work over some days there by giving him the opportunity to compress all the week hours to reduced days

Also, it can be describe as a flexible schedule where a full work week is completed in fewer than five days by increasing the number of hours worked per day. The more common examples/options or formula are; -

- ❖ Four 10 hours days i.e. 10/4
- ❖ Three 12 hours days i.e.12/3
- ❖ A week of five 9 hours days followed by a week of four 9 hour days i.e. days[9/5-9/4]

A two weeks of work compressed into nine and a half week work i.e. 9/80.

FIG.2 DIAGRAMMATIC EXAMPLE OF A COMPENSATED WORK WEEK I.E. THE 9/80 WORK SCHEDULE.

WEEK 1	BIWEEKLY HOURS WORK
Monday	9
Tuesday	9 or 4
Wednesday	9
Thursday	9
Friday	4 or 9

WEEK 1	BIWEEKLY HOURS WORK
Monday	4 or 9
Tuesday	9
Wednesday	9 or 4
Thursday	9 or 4
Friday	9

(Total hours worked=80)

ADVANTAGE OF COMPRESSED WORK WEEK

- ❖ Allows workers more leisure time and shopping time, and permit them travel to and from a non-rush times
- ❖ Reduce absenteeism, tardiness and turnover.
- ❖ Result in higher productivity due to fewer interruption during working hours
- ❖ Improves computer access with on line activity during non-peak hours
- ❖ It reduces machine downtime in manufacturing
- ❖ Expand option for communicating with business in other time
- ❖ Increase employee enthusiasm especially towards non-working day/free day
- ❖ Increase employee personal time and help their undisturbed time for self-work
- ❖ Accommodate employee`s commuting needs
- ❖ It reduces workers nonproductive time since their compressed schedule is maximally utilized
- ❖ Method perfectly okay for companies interested in meeting certain output or practicing the just – in time production as it increase their productivity for such period.

3.3 CONSTRUCTS ON IMPLEMENTATION OF THE SCHEDULE

These schedules require planning. The more carefully planned, the more likely all involved will see the benefits and better the chances for success. Employee involvement in the planning, implementation, and evaluation is strongly encouraged as it can lead to better business decisions for the work unit. The paths:

- (1) **DEVELOP A PLAN:** Consider all aspects and potential impacts on the work unit. Create a plan that outlines the specific arrangement for the work unit. What is gained by using these schedule? Define the objectives and the benefits or impact to the work unit, manager, employee, co-workers and customers. Examine the work culture, nature of business and operational needs for the work unit to determine if these schedules are feasible.
- (2) **DEVELOP SELECTION CRITERIA:** The Manager determines what factors to consider when making decisions on

requests but primary are always operational needs in relation to job assignments and then the jobholders. These factors should be worked out ahead of time and part of the written plans

- ❖ Establish criteria for approving request: Some ideas include possible benefits to the organization, potential drawbacks, requests by others in the work unit, duties of the job and be effectively performed with the new schedule, the level of staffing and supervision needed at various times, the level of service that would be provided to customers, the schedules of other employee outside the work unit whom the job must coordinate:
 - ❖ Establish a way to break ties for requests: Some ideas include performance, seniority, draw lots, or rotation.
 - ❖ Establish sanctions for abuse: Under what circumstances will the schedule be terminated? Example of abuse includes inaccurate time sheets or a continuing decrease in productivity that indicates an employee is not working during these hours. Notably, even in case where there is no abuse, the arrangement can be discontinued at any time.
- (3) **SUBMIT A WRITTEN REQUEST:** The employee submits a written request to the manager detailing the specific schedule desired. It should be submitted well in advance of the desired date for the new schedule. The employee should prepare to discuss the details of the request and participate in resolving any issues.
- (4) **COMMUNICATE AND DECIDE:** The key to success in mutual trust and respect. The employee and manager should meet to discuss any concerns, jointly resolve differences, and reach an understanding on the terms of the arrangement.
- (5) **DOCUMENT:** it is advisable to document the specific arrangement considering, these schedules are rights, not a right, and may need to be modified for business reasons. Both should remain flexible because both have an interest in making the arrangement work. Both are also accountable for responsible use of this schedule. Conclusively, it is better to try a pilot or trial run to test one or more options for a few months and address issues as they come up. Adjustments can be made along the way.

4 METHODS AND MATERIALS

4.1 RATIONAL FOR STUDY

In work oriented country like Nigeria, employees are expected to give their best and ensure that their productivity target are met and surpassed.

In order for this to be achieved, we must consider various factors that will assist the employee. This could range from available raw materials and tools, state of mind, method of payment and pattern of job scheduling etc.

Most importantly, is ensuring that their job scheduling is properly done to the extent that the worker will be satisfied and be willing to go the extra-mile for the company.

This is done in this study to see the impact of using flextime and compressed workweek on employee's productivity.

A study like this after thorough investigation would help us to

- See the out- datedness of the former pattern.
- Provide us with in-depth knowledge on the new job-scheduling pattern.
- See the importance and benefit of their application.
- Achieve the employee productivity desired.

4.2 RESEARCH METHODOLOGY

- The study depends on both primary and secondary data. Primary data have been collected with the help of questionnaires which contains questions relating to the personal profile of respondents and others on flextime and compressed work. The study was conducted with 50 staffs of Nigalex Aluminum Oshodi and 100 Eko Electricity Distribution Company staffs to ascertain the relevance of questions. Further, company officials and academic peers have also been contacted to obtain their views on the questionnaires. Secondary data have been collected from various facets of Human resources journals, magazines and websites. A total of 100 questionnaires

which represents 66.7% of the respondents was returned. Data collected have been analyzed using chi-square.

-

4.3 Research Instrument

- The questionnaire applied was designed to gather demographic information of the respondent employee, his/her perception of flextime and compressed week. Each questionnaire has two sections.
- Details of the measurement are as follows:
 - a. For the demographic variables gender, work experience (years) job status, age and qualification were measured.
 - b. For responses on flextime and compressed workweek, 10 items each were used to measure their responses on a 5 point likert scale ranging from strongly agree, agree, undecided, decided and strongly disagree. (Spreitzer 1995) adapted.

-

4.4 Reliability Analysis

- Reliability of the instrument was one of the concerns to this study. The reliability scale text was utilized to evaluate the validity of the impact i.e. impact of flextime and compressed workweek on productivity on the structured questions. According to Tavakol and Dennick (2011) reliability is concerned with the ability of an instrument to measure consistently. Reliability of an instrument is closely associated with its validity. An instrument cannot be valid unless it is reliable.
- In determining the reliability of the instruments, the Cronbach's Alpha was used to measure the reliability of the comparison and a test score of .75 was obtained. This shows a relatively high reliability.

- 5 RESULTS

-

5.1 HYPOTHESIS 1

H0: Flextime and compressed workweek job scheduling are not acceptable to the company

H1: Flextime and compressed workweek job scheduling are acceptable to the company.

From our calculated and tabulation, the $X^2_{cal} > X^2_{tab}$.

Going by our decision rule, we do not accept the null hypothesis, meaning "Flexitime and compressed work week are acceptable to the company.

5.2 HYPOTHESIS 2

Ho: Flexitime and compressed work week have no impact on job scheduling.

H1: Flexitime and compressed work week job have impact on job scheduling

From our calculated and tabular, the X^2 Tab < X^2 Cal.

Going by the decision rule, we do not accept the null hypotheses meaning "Flexitime and compressed work week have impact on job scheduling

HYPOTHESIS 3

Ho: Flexitime and compressed work week have no significant impact on employee productivity.

H1: Flexitime and compressed work week have a significant impact on employee productivity.

From our calculation and tabulation the X^2 Tab < X^2 cal.

Going our decision rule, we do not accept the null hypothesis meaning "Flexitime and compressed work week have a significant impact on employee productivity

EMPIRICAL FINDINGS AND DISCUSSIONS

From the research work, which was based on interaction, interview and the administered questionnaires, the following things were found out:

- 1) Flexitime and compressed workweek is new to almost all the workers.
- 2) Flexitime and compressed is not in use in these company as at now..
- 3) Few of the workers are satisfied about their present scheduling options and do not want the flexitime and compressed workweek.
- 4) Many of the workers want the flexitime and compressed work adopted, as it will help them.

From the findings of the research it can be made clear now that

- 1) All the scheduling options used over time has got no solution to the workers problem.

- 2) Many of these workers want the flextime and compressed workweek introduced in their company.

CONCLUSION AND RECOMMENDATION

Although there are a lot of anticipated problems that could occur if these scheduling options are adopted. However, it is conclusively agreed that it will be easily overcome. The scheduling options will be of relief to employee's time management in particular and how their jobs are schedule in general.

To have the full benefit of implementation, the following are recommended

ADOPTION OF THE SCHEDUELING OPTIONS

It is expected that these companies will adopt the use of these scheduling options if they really want the progress and time management of their staff.

USE OF EXPERT

Expert in the field of these options are expected to be engaged to do the work of implementation as it gives the company leverage in the anticipated problem.

EDUCATING STAFF ON THE BENEFIT

An average mind and staff will always resist change. In order to avert the resistance and passive attitude of the staffs they should be well educated on the benefits of these scheduling options.

UNEXPLOITATIVE IMPLEMENTATION

The company should not make the staff slaves by infringing on their chosen flextime and compressed work week day. They should allow them to judiciously use it to their optimal satisfaction.

GIVE TIME FOR THE OPTIONS APPRAISAL

A considerable time of at least two (2) years should be given for the appraisal or effectiveness of these options. It could also be used as a time to change the flextime and compressed workweek schedule of each staff.

PROVISION OF OTHER BASIC AMENITIES

The fact that management has granted some of these staff free time should not stop them from being compensated paid and remunerated properly with other benefits.

JUDICIOUS USE OF TIME

The company should ensure that the staffs actually use this period to benefit

their family and improve their health, moral and academic status. They must ensure it's not time to get involve in frivolities that may make them worn-out when they resume work.

PROPER MANAGEMENT OF WORKERS CHOICE

The administrative department should ensure that there is an adequate distribution of the time based on choice. Where we have more preference for particular options e.g. 10-12noon for flextime and 4/10 for compressed work, the allocation of the options should be carefully done with more preference given to the women, and also the reason/need for the option chosen.

REFERENCES

Beach S. Dale (1980) Personal Management of Peoples Work, 4th Edition,

Macmillan Publishing Company Plc., New York.

Blank, Rebecca M. (1988) "Part-Time and Temporary Work "Washington DC; US DepartmentOf Labour Journal on Investing in people: 317- 696

Buckley, M. Ronald, Diane C (2000) "A Note on the Effective of Flextime as an Organization Intervention". Washington, DC. Public Personal Management 16, no.3

Cox, J. and Dale, B. G. (2001). Service Quality and Ecommerce: An Exploratory Analysis. *Managing Service Quality*, 11 (2), pp. 121-131.

Hartmann, Heidi, and Lapidus (1989): "Temporary Work" Washington DC. US Department of Labour Journal on Investing in people. No2 .317- 679

Igbochi G.N (1990) Management: A functional Approach 1st Edition; Model Academic Pub. Nigeria Limited, Lagos.

International Institute of Sustained Dialogue (2004). The concept of Relationship.

<http://www.sustained dialogue com.>

Kerka, Sandra (1988) "Alternative Work Schedule: Changing Times for a Changing Workforce". Washington DC. Journal of Bureau of National Affairs No.4, 305- 501

Kerka, Sandra (1990) "Flexible Work Schedules" Washington, DC. ERIC DIGEST, 321- 157

Naeem, H. and Saif, M. I. (2010) 'Employees Empowerment and Customers' Satisfaction in Pakistan'. *African Journal of Business Management* 4, (10).

Nicholson, C. & Broione, P. (2012) Employee Empowerment: Towards Greater Workplace Democracy. www.centreforum.org/assets/pubs/workforce_emocracy.pdf.

Nwachukwu, C.C (1988) Management: Theory and Practice Africana First Publishers, Onitsha, Nigeria.

Obisi C. (1996): Personnel Management, Jeeboard Enterprises, Ibadan

Ogutu, M. and Oloko M. (2012) 'Influence of Power Distance on Employee Empowerment and MNC Performance: A study of multinational Corporations in Kenya'. *Education Research Journal* 2 (2): 47-61.

Ongori, H. & Shunda, J. P. W. (2008) 'Managing Behind the Scenes: Employee Empowerment'. *The International Journal of Applied Economics and Finance* 2 (2) 84-94.

Ongori, H (2009) 'Managing Behind the Scenes: 'A Viewpoint on Employee Employment'. *African Journal of Business Management* (1) 009-015.

Robbins, S.P. (2001) Organizational Behaviour. 'Concepts Controversies & Applications. Prentice Hall International Inc.' USA.

Staines, Graham L (1989): "Working Hours Flexibility" Washington, DC. ERIC DIGEST, NO7 317- 689

Tavakol, M. & Dennick, R. (2011) 'Making Sense of Cronbach's alpha'. *International Journal of Medical Education* 2, 53-55
www.ijme.met/archieve/2/cronbachs-alpha.pdf

Women’s Bureau (1988): “Flexitime Work Styles: A Look at Contingent Labour” Washington,

DC ERIC DIGEST, NO 3 305- 347.

APPENDICES

Descriptive Statistics

Here the respondent’s characteristics and demographics would be shown; the profile of the respondents would include sex, job status, years of experience, age and qualification The tables below gives a graphic detail of the respondents demographics.

Table 1

DISTRIBUTION OF RESPONDENT BY SEX

SEX	NUMBER	%
Male	80	80
Females	20	20

Total	100	10
-------	-----	----

Source: field survey, 2015

Table 2

DISTRIBUTION OF RESPONDENTS BY YEARS OF WORK

YEARS OF WORK	NO	%
1-5	40	40
6-10	25	25
11-15	20	20
16-20	10	10
21-25	5	5
TOTAL	100	100

SOURCE: Field survey, 2015.

Table 3

DISTRIBUTION OF RESPONDENTS BY POSITION STAFF LEVEL

POSITON/STAFF LEVEL	NO	%
Management	20	20
SUPERVISORY	30	30
Junior staff	50	50
Total	100	100

Source: field survey, 2015.

Table 4

DISTRIBUTION OF RESPONDENT BY AGE

AGE	NUMBER	%
Below 40	45	45

Above 40	55	55
Total	100	10

Source: field survey, 2015

Table 5

DISTRIBUTION OF RESPONDENT BY QUALIFICATION

SEX	NUMBER	%
OND/NCE	33	33
HND/B.SC	52	52
MBA/M.SC	15	15
TOTAL	100	100

Source: field survey, 2015

HYPOTHESIS 1 TABLE

VARIABLE	1	2	ROW TOTAL
Strongly Agrees	10 (7)	4 (7)	14
Agrees	52 (49)	46 (49)	98
Undecided	9 (10.5)	12 (10.5)	21
Disagree	18(26)	34 (26)	52
Strongly Disagree	11 (7.5)	4 (7.5)	15
Total	100	100	200

HYPOTHESIS 2 TABLE

VARIABLE	3	4	ROW TOTAL
Strongly Agrees	10 (8)	6 (8)	16
Agrees	70 (60)	50 (60)	120
Undecided	8 (9)	10 (9)	18
Disagree	8(13.5)	19 (13.5)	27
Strongly Disagree	4 (9.5)	15 (9.5)	19
Total	100	100	200

HYPOTHESIS 3 TABLE

VARIABLE	5	6	ROW TOTAL
Strongly Agrees	37 (32.5)	28 (32.5)	65
Agrees	48 (45)	42 (45)	90
Undecided	6 (5.5)	5 (5.5)	11
Disagree	7(13.5)	20 (13.5)	27
Strongly Disagree	2 (13.5)	5 (3.5)	7
Total	100	100	200

PUBLIC SECTOR ACCOUNTING

IMPACT OF COMPLIANCE WITH FEDERATION ACCOUNT ALLOCATION COMMITTEE GUIDELINES ON THE FINANCIAL REPORTING OF KANO STATE GOVERNMENT

By

Dr. Hannatu Sabo Ahmad (Mrs.)
Senior Lecturer, Department of Accounting,
Faculty of Social and management Sciences,
Bayero University, Kano, Nigeria
hannatusabo@yahoo.com, +2348132515270
(Corresponding Author)

and

Prof. Dr. Kabiru Isa Dandago, FCA
Department of Accounting,
Faculty of Social and Management Sciences,
Bayero University, Kano, Nigeria
Email: kidandago@gmail.com, +2348023360386

Abstract

Empirical researches on issues relevant to compliance with legal and regulatory provisions in financial reporting of the public sector are on the increase in Nigeria, just as it is on the increase in the private sector of the Nigerian economy. Similar conclusions with regards to compliance with financial reporting regulations in the Nigerian public sector are not conclusive (Ahmad, 2012). The main objective of this study is to examine the extent of compliance with Federation Account Allocation Committee (FAAC) Guidelines 2003 by Kano State Government in the preparation of its

annual accounts and reports. This study uses ex-post facto research design. Documentary data were obtained from the audited annual reports and accounts of Kano State Government from year 2003 to 2012. Nonparametric test using Kruskal-Wallis test was used in testing the hypothesis of the study. Overall compliance index recorded 90.29%, with all the requirements (R_1 to R_7) and P value of 0.0001 further justifies significant compliance. Based on this finding, the study concludes that there is compliance with the requirements of FAAC (2003) in the annual reports and accounts of Kano State Government. Yet compliance is not 100%, which signifies an element of non-compliance with some variables in the period of the study. The study recommends that Kano State Government should comply fully with the requirements of FAAC (2003) particularly on the statement of notes to the financial statements, which is found to be inadequate, in order to improve the accountability and transparency position of the government.

Keywords: Federation Account Allocation Committee, Financial Reporting, Compliance Index, Accountability, Transparency

1.0 Introduction

Financial reporting is an integral part of governance. It essentially involves preparing and issuing financial statements. Financial statements are formal records of financial activities of an entity (public or private) which show their financial condition for a given period of time. They are usually expected to comply with legal, regulatory and professional requirements. Financial reports communicate accounting information (Meyer, 1980). These reports tend to focus on communicating financial position and results of operations. Jones and Pendlebury (2000) view financial reports as annual reports and accounts, a single document produced by companies which satisfies not only statutory requirements but also includes materials at the discretion of management. In private sector, some financial statements are required by company law 1990 to be published (income statement, balance sheet), some are required by accounting standards (cash flow statement); together with accompanying notes, these are known as financial statements. They are audited (as part of statutory audit) and the subsequent audit report is published in the annual report and accounts. In addition, the law requires the directors of the company to publish a report and prescribes many disclosures in it. The final element of the annual report and accounts is a

statement from the chair of the company, which is at management's discretion in terms of form and content.

Financial reporting in public sector is principally in the form of financial statements and annual estimates. Section 24 of the Finance (Control and Management) Act 1958, (as amended), requires the Accountant General to prepare eleven (11) main financial statements. In addition to these, there are other twenty five (25) supporting and sub-supporting statements, totaling thirty six (36) statutory statements to be prepared.

The criticisms against Government accounting and financial reporting in Nigeria have been that the statements were not only too many, but also disjointed, unrelated, lack summation and very difficult to understand. Absence of a uniform Reporting Requirement is another issue. The legal requirement is for the Accountant-General to prepare and submit to the Auditor-General the actual and budgeted expenditure as well as the revenue of a given year. The best approach to meeting this legal requirement had been a matter of choice by the Accountant-General. The end product is varied and numerous approaches by the Accountants-General, both at the State and Federal levels. Consequently, no meaningful comparison could be made. That the supporting sub-statements, both in formats and contents, have little or no use to many of the end users; and that the heavy reliance on Finance (Control & Management) Act 1958 leads to producing financial reports not on absolute professional footing, therefore may not give room for adequate assessment of financial accountability and transparency of government (Technical Sub-Committee of FAAC, 2002).

In order to deal with these and similar problems, an ad-hoc committee was constituted by the Technical Sub-Committee of the Federation Account Allocation Committee (FAAC); at the FAAC meeting of 15th August, 2001 with the following broad objectives: To examine the incomparable nature of the financial statements of Federal, States and Local Governments; to examine the case for standardization; to fashion out a new financial reporting format for both the Federal, States and Local Governments that is informative, understandable, and comparable.

In September 2003 the report of the ad-hoc committee was approved. The report approved seven financial statements for the three tiers of government. These are: (i) Responsibility for financial Statements, (ii) Statement of Opinion of Auditor General, (iii) Cash Flow Statement, (iv) Statement of Assets and Liabilities, (v) Statement of Consolidated Revenue Fund, (vi) Statement of Capital Development Fund and (vii) Statement of Notes to the Financial Statements.

Compliance with legal and regulatory provisions is a user perspective of corporate financial reporting (The Stamp Report, 1980). Empirical researches on this topic are on the increase in Nigeria, as it is for profit firms. For instance, literature has documented a number of compliance studies in public limited liability companies (Kantudu, 2006; Ekoja, 2006; Mamman, 2006; Tanko, 2006 and Barde, 2009), up to now, empirical conclusions with regard to nonprofit organizations are not conclusive.

The question is: to what extent does the financial reporting of Kano State Government comply with requirements of the FAAC (2003)? How do we determine the extent of compliance with FAAC (2003) in the annual reports and accounts of Kano State Government? The main objective of this study is, therefore, to examine the extent of compliance with FAAC (2003) in Kano State Government's annual accounts and reports. Based on the statement of the problem and the objective of the study, the following null (H_0) hypothesis was developed to guide the study:

H_0 : Kano State Government does not comply significantly with the requirements of FAAC (2003) in its financial reporting. The study covers a period of ten years (2003 to 2012).

2.0 Literature Review

2.1 Review of past Efforts at Standardization of Government Financial Reporting System

Before designing a new financial reporting system, it is essential to carry out a thorough review and appraisal of existing financial reporting system with

a view to identifying the inherent deficiencies in the present system. In the past, considerable efforts had been made by the Government to standardize the financial statements by all tiers of Government resulting in the setting up of sub-committees to fashion out standard reporting formats. The reports of the various committees before the FAAC (2001) are reviewed and summarized below.

2.1.1 Report of the 1984 Committee

In its report, the Committee found great disparity between the Accounts of Federal, States and Local Governments in terms of statements and formats of presentation. It also found that it was difficult for users to collate; align and interpret the information thus presented. The Committee consequently recommended sixteen statements to be adopted by the Governments in the Federation. The statements are similar to the current financial statements prepared by the Federal Government. Other recommendations in its report include: Detailed procedures for accounting for cash receipts, payments, and fund accounting; Cash basis as basis for the preparation of Government accounts and memorandum ledger accounts or register kept for investment; Loan raised should be utilised for the purpose it is meant for with Accountant-General providing the details and breakdown.

Although the key recommendations were accepted and implemented the standard reporting formats were not uniformly adopted.

2.1.2 Report of the 1998 Committee

The Committee was appointed to formulate an accounting model for the three tiers of Government in Nigeria. The setting up of the Committee was provoked by IFAC "Exposure Guidelines for Governmental Financial Reporting" which proposed cash, modified cash, modified accrual and accrual basis of accounting for comments by member bodies towards having an accounting model. Accrual basis was adopted and the Committee had the mandate to fashion out standard format for its application.

The Committee noted that many countries of the world are now applying the Accrual concept which enables Government to have a clearer position as it relates to assets and liabilities, revenue and expenditure, net worth as well as insight into actual budgetary performance. The Committee then recommended thus: One format of accounting for all the three tiers of Government; Federal Account to be reported upon by the Accountant General of the Federation as Trustee Fund Account; Each tier of Government should report as an entity; Accounting policies (Historical cost concept, Revenue and Expenditure to be accrued, Assets should be depreciated on straight line basis, Unallocated stores to be valued at cost, Provision to be made for doubtful debts and bad ones written off, Statement under the accrual concept. Five Statements were recommended for Federal, State and Local Governments fashioned after that of New Zealand which has ten. (i) Statement of Responsibility signed by Accountant-General or Treasurer. (ii) Report of the Auditor-General. (iii) Statement of Assets and Liabilities. (iv) Statement of revenue and Expenditure. (v) Statement of Cash Flow. (vi) A four columnar format showing the Budget, Narration and Actual for both Current and preceding year. For logistics or other technical reasons this report was never considered (FAAC, 2002).

2.1.3 Report of the 1999 AGF's Committee on the Review of Federal Government Financial Statements

Although an interim report of this Committee was submitted in April 2000. Its final report which was submitted in January 2002 contained the following recommendations:

- a) The published financial statements of the Federal Government of Nigeria should be structured under three main headings as follows:
 - i) Eleven (11) main statements,
 - ii) Eight (8) sub-statements;
 - iii) Fourteen (14) supporting sub-statements.
- b) The eight sub-statements are to serve as schedules to the main statements, while the last category of fourteen supporting sub-statements could serve as data for management information only.

For logistic reasons the final report was not available for consideration before the Technical Sub-Committee of FAAC was set up in 2001.

2.2 Users of Financial Statements and their Information Needs

In general, Financial Statements are drawn up in order to convey important financial information to those with a right to be informed i.e. the various users: internal and external. The internal users of Government financial information are those who are directly involved in the day-to-day operations of Government activities. They include: Members of the executives and their advisers, Officers in charge of Control function/departments and divisions or units of Government. The external users include: Investors and Creditors - who are entitled to information which allows them to assess whether Government is likely to be able to meet its commitments as they fall due; Consultants, Accountants, Economists, and other professional interest groups including Lawyers and Researchers. Sectional group i.e. political parties, labour unions, organized private sector and chamber of commerce, industry, agriculture etc; Oversight bodies i.e. Legislature, Legislators and ad-hoc committees (GASB,1987, IFAC, 2001, Belkaoui, 2002).

Although the users described above have a wide range of information needs and some groups may place a higher or lower priority on certain types of information than others, they often have similar information needs. The Public Sector Committee of IFAC (2001) considers that, taken as a collective group, users expect that government financial reports will help them to: Assess the sources and types of revenues; Assess the allocation and use of resources; Assess the extent to which revenues were sufficient to cover cost of operations; Predict the timing and volume of cash flows and future cash and borrowing requirements; Assess the government's ability to meet financial obligation, both short and long term; Assess the government's or entity's overall financial condition; Provide the public with information concerning those assets held on behalf of taxpayers, specifically information on ownership and control, composition, condition and maintenance; Assess the financial performance of the government or entity in its use of resources; Assess the economic impact of the government on the economy; Evaluate government spending options and priorities; Assess whether resources were used in accordance with legally mandated budgets and other legislative and related authorities such as legal and contractual

conditions and constraints; and Assess the government's or entity's stewardship over the custody and maintenance of resources.

2.3 Accountability and Transparency in the Public Sector

The accountability of public sector organizations is a much discussed issue in the accountancy literature. Jackson (1982: 220) defines the term as “accountability involves explaining or justifying what has been done, what is being done and what has been planned... Thus, one party is accountable to another in the sense that one of the parties has a right to call upon the other to give an account of his activities”. Governmental Accounting Standards Board (1987), in their concept statement No.1, views accountability as the ‘paramount objective’ in financial reporting. Similar themes occur in discussions on a conceptual framework for the public sector, with writers focusing on issues such as the objectives of financial reporting and the information rights and needs of users (ASC, 1975; FASB, 1980; and CICA, 1980). Mayston (1992: 228) states that “As a normative objective for financial reporting, the meeting of users’ needs has now been widely accepted as the central objective by a long series of reports on the objectives of financial reporting in the private sector and in the public sector”. Ayitte (1992) is of the view that accountability is a shorthand term for fairness, responsiveness honesty, and exemplary leadership. It means that office holders are liable to responsible and answerable for performance by those affected by their decisions such as shareholders, the public and superiors in the work place. Also, Johnson (1996) sees accountability as the obligation to answer for a responsibility that has been conferred (Johnson, 1996).

By the nature of accountability, all those who have any role to play at any point in the organizational process carry the responsibility to account for actions undertaken (United Nations Development Programme, UNDP 1966:2). Accountability is enhanced by the extent to which the duty to answer is discharged. Oral representation or verbal account of actions represent the minimum and weakest form in the discharge of responsibility for accountability, it becomes strengthened and even stronger if account is documented in writing and backed by supporting documents to evidence

claims in the account. The form and contents of accountability is further enhanced by procedural influences such as timeliness (or report authentication and communication) as well as the process, details of form and contents, (Aruwa, 2002).

Accepting the position that both accounting and accountability are with meeting the information needs of users, the question then arises as to whom a public sector organization is accountable? The Governmental Accounting Standards Board (GASB, 1987) highlights three groups as primary users of public sector organizations' financial reports: the citizenry, legislative and oversight bodies, and investors and creditors. Similar lists have been provided by other writers (CICA, 1980; and FASB, 1980). An examination of these lists shows a common position where it is accepted that there is the need to report to those outside the immediate management of a public sector organization.

According to Maipose (2000:91), accountability questions should be concerned with exploring the criteria and appropriate procedures, which ought to govern expenditure choices as well as the institution... which exist to enforce such accountability. Four important criteria are regarded as basic to public service accountability. These include: Fiscal accountability, Managerial accountability, Programme accountability and Individual accountability (UNDP, 1996:5). Fiscal accountability is concerned with adherence to applicable laws and regulations, consistency with appropriate accounting principles and traditions, accuracy and fairness of reports, and complete legitimacy of expenditure. Managerial accountability deals with the generation of essential information for decision making, and the need for economy, efficiency and effectiveness of operations. Programme accountability is concerned with overall evaluation of programme impact and extent to which intended goals and aspirations are attained. Individual accountability is related to the personal qualities and conduct demonstrated by accountable officers. It involves such attributes as honesty, trust, probity and integrity. It is held that individual accountability enhances overall transparency (UNDP, 1996:5).

This shows that public accountability encompasses more than merely accounting for, and reporting on financial stewardship. Public accountability requires agents to account for the way in which they have managed the resources from both an administrative and political perspective. Jubb and Kelso (1998) further stressed, public accountability includes accountability for policy (fiscal accountability), process (programme operational accountability), equity (individual accountability).

Several scholars have argued that the current focus on financial accountability in the public sector will result in an erosion of public accountability as the information provided to meet financial accountability purposes does not provide information about such issues as fairness, equity and process (Williams, 1987; Parker and Gould, 1999; Coy, Fisher Gordon, 2001; Jubb and Kelso, 1998). On the contrary, Aruwa (2005) argues that, financial reporting is the best index of public service accountability. That financial reporting provides the bases for evaluating fiscal, managerial, operational and individual accountability in the public service. Similarly, (Hyndman and Anderson, 1995) opine that annual report is the key document in the discharge of accountability to external users.

Transparency is a feature of accountability. Generally, transparency is seen as the ability of the organization or individual to be open to public scrutiny. Transparency is an ethical concept implying openness, honesty, candor, and forthrightness in official dealings and relationships. It is the negation of corruption and unwholesome practices in the public service. Maipose (2000) explains transparency as a characteristic of governance which refers to the availability of information to the public on the transactions of the government and the openness of the decision-making process.

According to Muhammad (2004:170), accountability is about giving the required explanations for action taken, which is inseparable from transparency, because any accounting report that lacks transparency will be misleading and fraudulent, since it does not give the correct view about the situation and the organization. Within the framework of accountability in public settings, vital offices of the Accountant General and the Auditor-

General with varying and complementary functions exist. Accountability has mandated the Accountant-General of the Federation and his minor offices at states and local governments to ensure adequate systems in public offices, for the control of the collection and disbursement of public funds and for the coordination of their systems (Section 168 of the 1999 Constitution). Accountability will not be complete without audit. The supreme audit office of Nigeria is occupied by the Auditor-General as required by Section 125 to 127 of the 1999 Constitution.

2.4 Financial Reporting Model by FAAC (2003)

Bearing in mind the deficiencies of the financial statements as previously discussed, the Financial Reporting Standard Model was fashioned out along the following lines:

Statement No. 1: Responsibility for financial statement.

Statement No. 2: Statement of opinion of Auditor General.

Statement No. 3: Cash Flow Statement.

Statement No. 4: Statement of Assets and Liabilities.

Statement No. 5: Statement of Consolidated Revenue Fund.

Statement No. 6: Statement of Capital Development Fund.

Statement No. 7: Notes to the Financial Statements.

The content of these statements are briefly explained in table1 below.

2.4.1 Variable for Compliance with FAAC (2003)

The audited annual reports and accounts of the state were used to establish compliance with FAAC (3003) requirements by the State's audited annual reports and accounts. The requirements of FAAC (2003) for the form and contents of financial reports of

States and federal governments are presented in Table 1. This is used to obtain the compliance index.

Table 1: Requirements of FAAC (2003) for the form and contents of financial reports

Variables for Compliance with FAAC (2003)	Requirement
<p>Statement No. 1: In this statement, the Accountant-General will confirm his responsibly that the financial statements have been prepared in accordance with the provisions of the Finance (Control and Management) Act of 1958 as amended and in compliance with Generally Accepted Accounting Practice (GAAP).</p>	R ₁
<p>Statement No. 2: It is the Auditor-General's Certificate to the effect that proper audit has been carried out in respect of the financial statements prepared by the Accountant-General.</p>	R ₂
<p>Statement No. 3: The Financial Statement reporting model associated with the Cash basis of accounting is a CASH FLOW STATEMENT that reconciles opening and closing balances of cash and cash equivalents. The cash flow statement should report cash flows controlled by the entity during the period classified into operating, investing and financing activities. Such classification should be reported in a manner which is most appropriate to its activities. Additionally, an entity should report cash flows from operating activities on the basis of gross cash receipts and payments for each major class.</p>	R ₃
<p>Statement No. 5: The Consolidated Revenue Fund is the fund into which all receipts accruing to the Federal Government are credited. These in the main are receipts from Federation Account and other sources. All recurrent expenditure of Government are debited to this fund.</p>	

<p>Contribution to Capital Development Fund, if any, is also charged to this Fund. Finally, the effects of the operation of the contingency fund as well as issues and repayments of Treasury bills are brought into this fund.</p>	<p>R₅</p>
<p>Statement No. 6: The Capital Development Fund is used to finance general capital expenditure of Government. The receipt of the Development fund shall consist of: The product of loans raised by Government for capital projects; Development grants made to Government by Foreign Governments or Agencies like United Nations, UNESCO, etc; Sums from time to time authorised by law, or by an Act of the Assembly to be transferred from Consolidated Revenue Fund.</p>	
	<p>R₆</p>
<p>Statement No. 7: For purposes of user's understandability and comparability, notes to the accounts are normally presented in the following order.</p> <ul style="list-style-type: none"> ❖ Statement of compliance with any known standards (e.g IPSAS) ❖ Statement of accounting policies applied; ❖ Supporting information for items presented on the face of the Financial Statements in the order in which each line is presented, and ❖ Other disclosures or relevant supporting statements/schedules which may include any or all of the following: <ul style="list-style-type: none"> i) Statement of Revenue Analysis by Head ii) Statement of Expenditure Analysis by Head. iii) Statement of Project Payments - Summary. iv) Statement of Investments. v) Statement of Public debt. vi) Statement of Grants and Subsidies. vii) Statement of Special and Miscellaneous Funds such as Ecological Funds, Disaster Relief Funds, 	<p>R₇</p>

etc.	
------	--

Table 1: Requirements of FAAC (2003) for the form and contents of financial reports

Source: Generated by the Research from

Based on the general guidelines presented in Table 1, compliance with FAAC (2003) in the financial reports of Kano State Government (the dependent variables) is a function of seven (7) requirements, represented by R₁ ... R₂ ... R₇., a maximum score of 10 points was assigned to denote complete compliance to a variable, while 0 denotes noncompliance. Where a variable has more than one requirement, it was divided into sub-variables (ie R₁, R₃ R₄ and R₇) and the 10 points apportioned among the sub-variables. This was done in order to ensure accuracy and fairness in the grading and the result expressed as a percentage, as follows:

$$Dc = \sum_i^n \frac{Ara}{Mra} \times 100$$

Where:

DC = Degree of compliance

Σ = Summation or addition

n = Number of expected variables to be complied with in the financial reports

Ara = Actual number of variables complied with in the financial reports

Mra = Maximum number of variables to be complied with in the financial reports

The following criteria presented in Table 2 were used to interpret the results.

Table 2: Criteria for Grading Compliance with FAAC (2003) by the Annual Reports and Accounts of Kano State Government

S/No	Percentage Score	Points	General Remarks
1.	70 – 100%	7 – 10	Strongly Complied
2.	50 – 69%	5 – 6.9	Semi Strongly Complied
3.	40 – 49%	4 – 4.9	Weakly Complied
4.	20 – 39%	2 – 3.9	Very Weakly Complied
5.	0 – 19%	0 – 1.9	Non Compliance

Source: Kantudu (2006)

2.5 Compliance Index

Compliance index has been described as a qualitative instrument designed to measure a series of items which, when the scores for the items are aggregated, gives a surrogate score indicative of the level of disclosure in the specific context for which the index was devised (Coy, 1995; Kantudu, 2006; Barde, 2009 and Ahmad, 2012). Information from the audited annual reports and accounts gave the degree of compliance with the requirements of FAAC (2003). The degree of compliance with the requirements was obtained through grading and scoring of the requirements consistent with Kantudu, 2006 and Barde, 2009). This total compliance index was used to test hypothesis of the study.

This study assigned equal weights to all the requirements (R_1 to R_7). This is consistent with prior compliance studies (Tower et al, 1999; Glaum and Street, 2003; and Barde, 2009). Literature has documented a wide support for equal weighing because it avoids subjective judgments (Wallace and Naser, 2005) provides neutral assessments of item , avoids clashes with user's preferences which are unknown (Chang, Most and Brain, 1983), matches with dynamic relative importance of items (Owusu-Ansah, 1998) and yields results similar to of those other weighting system (Zarzeski, 1996; and Principe, 2004).

3.0 Methodology

This study uses *ex-post facto* research design. Documentary data were obtained from the audited annual reports and accounts of Kano State Government from year 2003 to 2012. The audited annual reports and accounts were used to determine the extent of compliance with the requirements of FAAC (2003). Nonparametric test using Kruscal-Wallis test is used in testing the hypothesis of the study. The statistical technique is used because the distribution of data has not passed the normality test.

4.0 Results and Discussions

This section presents and discusses the results of the extent of compliance with FAAC requirements in the financial reports of Kano State Government 2003 – 2012. To achieve this, the research uses descriptive statistics and chi-square test (in addition to compliance index). The chi-square was also used to test the hypothesis of this study, restated below:

H₀: Kano State Government does not comply significantly with the requirements of FAAC (2003) in its annual reports and accounts

The results are illustrated in Table 3 indicating the level of the compliance for each of the nine elements (R₁ to R₇).

Table 3: Kruscal-Wallis Calculation Details

Group	No. of Points	Sum of Ranks	Mean of Rank
R ₁	10	400	40
R ₂	10	400	40
R ₃	10	400	40
R ₄	10	400	40
R ₅	10	400	40

R ₆	10	400	40
R ₇	10	85	8.5

Kruskal-Wallis Statistics is 60.797

The P value < 0.0001

Source: Financial Statements of Kano State Government (2003 to 2012)

Table 4: Descriptive Statistics/Compliance with FAAC (2003) Requirements

Requirements/ Group	Mean	Std dev	Observed	Expected	<i>LEVEL OF COMP (%)</i>
R ₁	10.0	0	100	100	100
R ₂	10.0	0	100	100	100
R ₃	10.0	0	100	100	100
R ₄	10.0	0	100	100	100
R ₅	10.0	0	100	100	100
R ₆	10.0	0	100	100	100
R ₇	3.2	2.44	32	100	32

Overall Compliance 90.29%

Source: Generated from the audited annual reports of Kano state government (2003 to 2012)

Table 4 shows the observed and required compliance as well as the compliance index, the mean, standard deviation and the level of significance relating to Kano State government compliance with the FAAC (2003) guidelines. In terms of compliance with the requirements, there was 100% compliance with six (6) out of seven (7) items of requirements (R₁, R₂, R₃,

R₄, R₅, and R₆), indicating that Kano State Government complied strongly with these requirements. The mean of 10 and the standard deviation of 0 further support this finding, which suggest no variation on the extent of complete compliance with the requirement, which fell within the strong application category. The sum and mean of ranks of 400 and 40 further support the results.

However, result shows variations in compliance with the other requirement, which is R₇ (statement of notes to accounts) which recorded only 32%, a very weak compliance. This result is in line with the mean of 3.2 and the standard deviation of 2.44, which means, compliance is low with this requirement over the period of the study, which fell within the low-application category based on the compliance index (Table 2). The sum and mean of ranks of 85 and 8.5 respectively further support the results.

Overall the P value of 0.0001 suggests a very significant in compliance amongst the variables of the study. Similarly, compliance index recorded 90.29% compliance with all the requirements (R₁ to R₇). This fell within the strong compliance category. Based on this finding, the study concludes that there is compliance with the requirements of Federation Account Allocation Committee (FAAC, 2003) by the annual reports and accounts of the State Government. Yet compliance is not 100%, which signifies an element of non-compliance with some requirements in some periods.

5.0 Conclusion and Recommendations

The FAAC (2003) efforts directed at standardizing the accounts of Federal Government with other tiers of Government would, undoubtedly, lead to greater benefits to all users of the Financial Statements. Based on the finding of the study, it therefore concludes that there is compliance with the FAAC (2003) guidelines in the annual reports and accounts of Kano State Government. Yet compliance is not 100%, which signifies an element of non-compliance with some requirements in some periods.

Notes to the financial statement are a very important part of financial reports because it explains in detail the contents of the other statements. It presents information about the basis of preparing the financial statements and the specific accounting policies selected and applied for significant transactions and other events. It discloses the information required by any relevant Standard that is not presented elsewhere in the financial statement. It also provides additional information which is not presented on the face of the financial statements but is necessary for a fair presentation of the entity financial position. For these and similar reasons, Kano State Government should equally give more importance to the 'the statement of Notes to the Financial Statement' as it does to the other six (6) Statements.

On this issue the Auditor-General, noted in the 'Report of the Auditor-General on the Accounts of the Government of Kano State for the Year ended 31st December' (2010:41) advised the Accountant-General to provide 'Notes to the Financial Statement' as required by the new format of presentation of Financial Statements, that is, requirements of FAAC (2003).

The Notes to Statements do provide the basic information that easily measures the stewardship role of government. Activities of government are summarised and adequately analyzed to reflect the cost and benefits received. This will enhance public accountability and transparency in public service.

REFERENCES

Accounting Standards Steering Committee, (1975). *The Corporate Report*, London, The Institute of Chartered Accountants of England and Wales.

Ahmad, H. S. (2012). *Financial Reporting and Public Accountability of Jigawa State Government 2000 to 2008*, A Ph D Thesis, Department of Accounting, Bayero University, Kano.

Annual Reports and Accounts of Kano State Government from 2003 to 2012

Al-Shammari, B. (2005). *Compliance with International Accounting Standards by Listed Companies in Gulf Cooperation Member States: An Empirical Study*, A Thesis submitted to UWA Business School, University of Western Australia for the award of Doctor of Philosophy in Accounting.

Barde, I. M. (2009). *An Evaluation of Accounting Information Disclosure in the Nigerian Oil Marketing Industry*, Ph.D Thesis, Department of Accounting, Bayero University, Kano.

Bordner, W. (1982). Improving Financial reporting by governments, *The Accountants Journal* (spring), pp. 10-15; (summer), pp. 28-35, an (fall), pp.23-36.

Brooks, R.C. (1992). Research in Government Accounting and Reporting, in Apostolou G. and Crumbly, D. L. *Handbook on Governmental Accounting and Finance*, 2nd ed., New York, John Willey and Sons.

Butterworth, P. Gray, R. & Haslam, J. (1989). The Local Authority Report in the UK: An Exploratory Study of Accounting Communication and Democracy, *Financial Accountability and Management*, Vol. 5, No. 2 (Summer 1989), pp. 73-87.

Chang, L. S., Most, K. S. & Brain, C. W. (1983). The Utility of Annual Reports: An International Study, *Journal of International Business Studies*,14(1),pp. 63-84.

FASB (2000), Financial Accounting Standards Board, Business Report Research Project, New York, (www.fasb.org).

Financial Accounting Standards Board (1980). Qualitative Characteristics of Accounting Information, *Statement of Financial Accounting Concept No. 2*, Stanford.

Finance (Control and Management) Act 1958, Government Press, Lagos.

Freeman, R. J. & Shoulders, C.D (1982). Defining the Governmental Reporting Entity, *Journal of Accounting*.

Greathouse, F. L. (1980). Objectives of Government Accounting and Financial Reporting, *The Government Accountants Journal*, Vol. 29, No. 1 Spring, pp. 43-50.

Holder, W. W. & Cherry, A. A. (1981). Financial Reporting by Governments: A Suggested Approach, *The Government Accountants Journal*, Summer, PP. 36-60.

Igram, R. & Robbins, W. (1992). A Partial Validation of the ASB User Needs Survey, Research in Governmental and non Profit Accounting, pp. 41-52. *In Financial Accountability and Management in Government Public Services and Charities*.

Ives, M. H. (1984). GASB Research on user needs and objectives of Government Financial Reporting: A Summary and Analysis', *Research in*

Governmental and Non-profit Accounting, Vol. 3 part B JAJ Press Inc. pp. 227-235.

Jones, D. R., Scott, R., Kimbro, L., & Ingram, R. (1985). *Needs of Users of Government Financial Reports*, (GASB, 1985).

Jones R. and Pendlebury M. (2000). *Public Sector Accounting*, England, Pearson Education Ltd.

Mamman, S. (2006). *Accounting for Leasing in Nigeria*, PhD Thesis, Department of Accounting, Ahmadu Bello University, Zaria.

Owusu-Ansah, S. (1998). The Impact of Company Attributes on Mandatory Disclosure and Reporting by Listed Companies in Zimbabwe, *International Journal of Accounting*, 33(5), 605-631.

Omolehinwa, E. O. & Naiyeju, J. K. (2011). *Theory and Practice of Government Accounting in Nigeria*, Lagos, Pumark Nig. Ltd.

Principe, A. (2004). Proprietary Costs and Determinants of Voluntary Segment Disclosure: Evidence from Italian Listed Companies, *European Accounting Review*, 13 (2), pp. 319-340.

Riahi-Belkaoui, A. (2002). *Accounting Theory*, Illinois, USA, Thomson, Fourth Edition.

Stamp, E. (1980). *Corporate Reporting: Its Future Evolution*, Toronto, Canadian Institute of Chartered Accountants.

Statement of Financial Accounting Concept No. 2 (1980). Qualitative Characteristics of Accounting Information, *Financial Accounting Standards Board*, Stamford

Statement of Financial Accounting Concepts No. 4 (1975). Objectives of Financial Reporting by Nonbusiness Organizations, *Financial Accounting Standards Board*, Stamford.

The Technical Sub-Committee of FAAC (2003). *Standardization of Federal, States and Local Governments Accounts in Nigeria*, Lagos, J. K.Consultants Ltd., VOL. 1 and 2.

Tower, G., Hancock, P., & Taplin, A. (1999). A Regional Studies of Listed Companies' Compliance with International Accounting Standards, *Accounting Forum*, 23 (3), pp. 293-305.

Wallace, W. A. (1985). Objectives for the Governmental Accounting Standards Board, *Research in Governmental and Non-profit Accounting*, Vol. 1 JAI press Inc., pp. 33-76.

Wallace, R. S.O. & Naser, K. (1995). Firm Specific Determinants of the Comprehensive of Mandatory Disclosure in the Corporate Annual Reports of Firms Listed on the Stock Exchange of Hong Kong, *Journal of Accounting and Public Policy*, vol. 4, pp. 311-368.

Zarzeski, M. T. (1996). Spontaneous Harmonization Effects of Culture and Market Forces on Accounting Disclosure Practices, *Accounting Horizons*, 10 (1), pp. 18-37.

Zubairu, M. (2009). *Introduction to Accounting Procedures in Nigerian Public Sector*, Kano, AIMA Printing and Advertising Ltd

MODERATING ROLE OF ORGANISATIONAL CULTURE ON THE RELATIONSHIP BETWEEN BUDGETARY PARTICIPATION AND ORGANISATIONAL PERFORMANCE IN FEDERAL UNIVERSITIES ACROSS NIGERIA

By

Akinniyi, K. O. (Ph.D., ACA)

Dept of Accountancy, University of Maiduguri, Maiduguri, Nigeria

peeyemi@yahoo.com

Ajibolade, S.O (Ph.D., FCA)

Department of Accounting, University of Lagos, Lagos, Nigeria

soajibolade@yahoo.com

Fagbemi, T. O. (Ph.D., ACA)

Department of Accounting, University of Ilorin, Ilorin, Nigeria.

olamidefag@yahoo.com

Ashogbon, F.O.

Dept. of Business Management, Tai Solarin University of Education, Ijagun,
Ijebu-Ode

fadeashogbon2001@gmail.com

Abstract

The aim of this study is to evaluate the moderating role of organisational culture on the relationship between budgetary participation and organisational performance among federal universities in Nigeria. A survey research design was adopted in this study. Multistage sampling was adopted to select 272 respondents from ten federal universities in both academic and non academic departments of universities across Nigeria. Relying extensively of primary data which passed reliability and validity tests, a structural equation model was used to test hypothesised relationships. Results of analysis showed that organisational culture significantly moderated the relationship between budgetary participation and organisational performance at $\beta = -0.922$. The policy implication of findings suggests that organisational cultural values of federal universities in Nigeria is an important element of

organisational life, which affects management control mechanisms as well as organisational performance.

Key words: budgetary participation, organisational culture, organisational performance

1. Introduction

In the wake of dwindling funding of federal universities in Nigeria, it becomes imperative to evaluate the performance of these organisations from the perspective of management accounting. This is because in the opinion of Mahfar and Omar (2004), management accounting is an integral part of a typical management process as well as an important tool for achieving high performance (Mustapha & Ghani, 2013). Evidence from literature has depicted budgeting as an arsenal in the field of management accounting. As a dicotyledonous cog, it consists of technical and behavioural elements. While the technical element focuses on mathematical derivation of income and expenses, the behavioural aspect focuses on how to get people to achieve the technical aspect (Raghuandan, Ramgulam & Raghuanda-Mohammed, 2012).

Management accounting has been recognised as an integral part of the accounting system of any organisation (Silva & Jayamaha, 2012). In particular the entire paraphernalia of the behavioural aspect of budgeting has been recognised as germane for securing organisational objectives as well as enhancing performance (Omolehinwa, 1989, Seaman, Landry, & Williams, 2011). However, difficulty in integrating results of researches on budgeting into real life situations, has initiated calls for the enrichment of management accounting studies to include human relationships (Ahmed, 2002; Anderson & Lillis, 2011). Basically, many early studies have ignored the social and organisational context in which budgeting systems operate (Merchant, 1981; Amat, 1991, Sejjaaka, 2010). Organisational culture, an important aspect of organisational life has been observed to have a significant impact on work behaviours, practices and ultimately efficiency of an organisation (Furnham & Gunter, 1993). According to Schein (1993), organisational culture can best be described as a pattern of shared basic assumptions and values among members of a group.

Inconsistencies in the relationship between budgetary participation and organisational performance which is an integral part of the behavioural aspect of budgeting, has provided an aperture for studies in management accounting to introduce exogenous variables (Noor & Othman, 2012). Consequently, in order to provide a logical reasoning for observed level of performance among federal universities in Nigeria, this study introduces organisational culture as a moderator variable for explaining the effect of budgetary participation on organisational performance. The remaining part of this paper proceeds as follows; literature review and conceptual framework, methodology, data presentation, analysis and discussion. The last section focuses on summary, conclusion and recommendations.

2. Conceptual framework and hypotheses formulation

The need to engage in budgeting activities by universities has been observed to be borne out of a need to balance inadequate funding with accountability for available resources (Mahd'd, Al-Khadash, Idris, & Ramadan. 2013). Theorists in the field of behavioural sciences have suggested that organisational culture, is a fundamental construct, which defines how efforts towards are directed towards improving managerial and organisational performance (Ouchi, 1981; Deal & Kennedy, 1982; Baker, 2002). It has also been argued, that organisational performance is enhanced when there is an interaction between organisational culture and aspects of management accounting systems such as budgeting (Agbejule, 2011).

From the behavioural perspective evidence from literature has shown that budgetary participation bears some level of influence on organisational performance. As an exogenous variable, organisational culture is observed as either having an internal focus or an external focus, which has the power to moderate the relationship between budgetary participation and organisational performance. This relationship is depicted in the Figure 1.

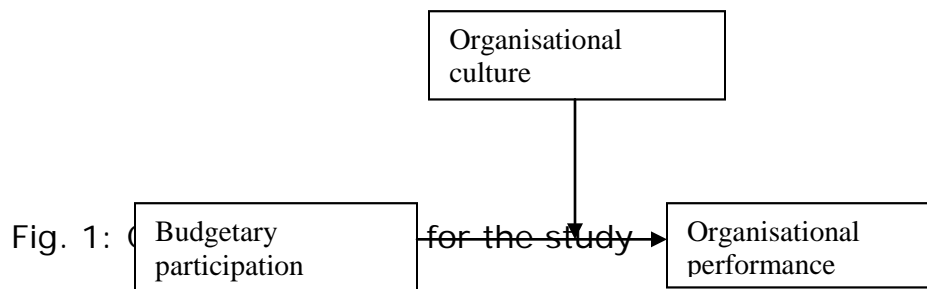

2.2 Budgetary participation

Budgetary participation is described as the extent of involvement of lower level managers in the budget process (Subramaniam & Mia, 2001; Hughes, 2008, Noor & Othman, 2012). In order ensure adequate and efficient allocation of available resources, budgetary participation has been observed to enable managers to have better understanding of challenges facing the organisation, so that resources are more effectively allocated (Lu, 2011).

2.3 Organisational culture

Organisational culture has generally being described as an acceptable way of doing things in a community or organisation (Schein, 1993). In terms of focus, it can either be internal or external (Huang, Fang & Liu, 2013) in an attempt to deal with challenges in the organisational environment. Premised on theory of organisational culture by Denison, Ehtesham, Muhammad and Muhammad (2011) observe organisational culture as a contextual determinant of organisational performance in terms of involvement, consistency, adaptability and mission. Relating these cultural values together, involvement and consistency are measures of internal focus while adaptability and mission are measures of external focus. On a horizontal line analysis, internal focus tends more to the left while external focus tends more to the right.

Organisations with predominant internal focus tend to place emphasis on formalised and structured work conditions. In addition leaders are conservative in nature and they encourage team spirit. On the other hand organisations with external focus place emphasis on growth, leaders are idealists, while employees are evaluated on qualitative values only. Team spirit is rarely encouraged (Cameron, & Michigan, 2004, Schimmoeller, 2010).

2.4 Organisational performance

Organisational performance of educational institutions can be observed in terms of efficiency as well as quality of their products (i.e the graduates). In the opinion of Ng'ang'a and Nyongesa (2012) performance is an indicator of success. With regards to an appropriate measure of performance, Scholars and practitioners have clamoured for both financial and nonfinancial measures (Kaplan & Norton, 1992; Rajendar & Jun Ma, 2005). The scorecard whether balanced, or not has been identified as a tool best suited

for evaluating performance of a typical university because of its ability to evaluate both financial and non-financial indices (Bogt & Scapens, 2011).

Relationships between budgetary participation and organisational performance have yielded conflicting results (Merchant 1981). To this end, Maiga and Jacobs (2007), suggest that the extent to which budgetary participation impacts performance requires more empirical reasoning. Premised on these positions and the conceptual framework of this study, the following hypotheses were tested.

H₁: Budgetary participation significantly affects organisational performance.

H₂: Organisational culture significantly affects organisational performance.

H₃: Organisational culture significantly moderates the relationship between budgetary participation and organisational performance.

Methodology

This study adopted a survey research design. For the purpose of confidentiality, the real names of the universities are not used in this study. Rather, identification numbers were ascribed.

Population and Sample

Population for this study comprised of heads of units and academic departments in federal universities in Nigeria. Universities considered in the population are those that have graduated at least one set of students. The heads of departments and units are budget holders who are responsible for the budgets in the respective units and departments. A multi-stage sampling technique was adopted in selecting fifteen out of total number of federal universities that met the population criteria. However, returns were obtained from ten of the fifteen universities. Random sampling technique was further adopted to select heads of departments in both academic and non-academic departments from sampled universities. Data gathering instruments were administered through personal administration. A total of 272 useable

responses were retrieved from the data gathering exercise. A response rate of 54% was considered satisfactory, based on the recommendations of Henri (2006).

Measures of variables

Budgetary Participation (BP)

Budgetary participation was measured with items adapted from Williams et al. (1990). The instrument contained six-items, five-point likert-type scale ranging from (1) "to a very little extent" to (5) "to a very large extent." Cronbach's alpha reliability for this variable was 0.91. For interpretation, an index of mean score was adopted as follows; 0 to 1.9- low; 2 to 3.9- moderate; greater than 4- high. This instrument has a Cronbach alpha value of 0.94.

Organisational performance (OP)

The balanced scorecard designed by DeBusk, Brown and Killough (2003) was adapted for this study. It comprises of four perspectives namely student (S), education & teaching (E&T), course development & human resources (CD & HR), and finance (F). Respondents were required to self evaluate performance on a 6 likert scale, measured from very poor to very good. For interpretation, an index of mean score was adopted as follows; 0 to 1.9- poor performance; 2 to 3.9- good performance; greater than 4.0 - very good performance. This instrument has a Cronbach alpha value of 0.94.

Organisational culture (OC)

This study adapted the work of Henri (2006), to measure organisational culture in terms of involvement (I), consistency (C), adaptability (A) and mission (M) cultural values. For each of these components respondents were required to express the extent of intensity on a scale of 25 for each of the cultural values. On the basis of focus, where; $\Sigma(I + C) > \Sigma(A + M)$, it suggest that the university has an internally focused OC, however, where $\Sigma(A + M) > \Sigma(I + C)$, it implies the university has an externally focused OC. This instrument had a Cronbach Alpha value of .70.

Tools of Analysis

A combination of descriptive and inferential statistical tools was used to analyse the data gathered. Descriptive statistics include measurement values of the variables under study. For inferential statistics, a structural equation model was fitted.

DATA PRESENTATION, ANALYSIS AND DISCUSSIONS

Measures of data from the sampled universities are presented in Table 1.

Table 1: Measurement values of variables used in the study obtained from responses

Code	OC							BP		OP	
	I	C	Σ	A	M	Σ	focus	mean	implication	mean	implication
1	21.81	37.03	59	20.91	20.25	41	internal	2.84	Moderate	3.8	good
2	17.24	37.58	55	25	20.18	45	internal	2.58	Moderate	3.9	good
3	26.5	28.13	55	24.29	21.08	45	internal	3.41	Moderate	4.1	very good
4	17.33	39.66	57	15.5	27.5	43	internal	3.03	Moderate	3.8	good
5	41.17	21.42	63	18.33	19.08	37	internal	2.99	Moderate	3.5	good
6	19.64	33.33	53	25.34	21.69	47	internal	3.1	Moderate	3.7	good
7	21.25	30.27	52	26.81	21.47	48	internal	3.08	Moderate	4.7	very good
8	25.18	36.31	61	16.07	22.44	39	internal	2.71	Moderate	4.2	very good
9	20.19	32.75	53	23.78	23.28	47	internal	2.72	Moderate	3.6	good
10	19.59	29.09	49	26.12	25.2	51	external	2.69	Moderate	3.2	good

Values from Table 1 shows that except for University with code 10, all other universities have an internal focus. Universities with internal focus OC, are characterised by high level of team spirit, in a formalised work environment. Leaders in these institutions are quite conservative in nature. On the other hand universities with external focus, place emphases on growth. Leaders are very idealistic in nature with a lot of concern for quantity rather than quality. With regards to level of participation, all the sampled universities exhibited a moderate level of budgetary participation. Observed level of performance shows three out of the ten universities have a very good score for their overall average level of performance.

Test of hypotheses

The hypothesised relationships in figure 1 were tested using AMOS 22. Two models were fitted using this statistical tool. The first model was without the moderation effect, while the second model contained the moderation effect. The SEM result of modelled hypotheses depicted a good fit with CFI (comparative-fit-index) = 1; NFI (Normed-fit index) = 1; PCLOSE >.05. Results of data analysis are presented in Table 2 and used to accept or reject advanced hypotheses.

Table 2: Summarised results for H₁, H₂ and H₃

Hypotheses	Variables		β	p	Decision
	Dependent	Independent			
H ₁	OP	BP	0.002	0.991	At p>0.05; hypothesis rejected
H ₂	OP	OC	-0.285	0.138	At p>0.05; hypothesis rejected
H ₃	OP	BP x OC	-0.92	0.00	At p < 0.000; hypothesis

			2	0	accepted
--	--	--	---	---	----------

From Table 2, it can be observed that a PB and OC alone have a low and non effect on organisational performance. Test of H₁, indicates a positive relationship between BP and OP, this is in line with previous studies. The negative relationship between OP and OC for H₂, suggests that more internally focused organisations tend to have higher performance scores. However the interaction of BP and OC has a high and significant effect on OP. This provides support for the proposition of Rose, Holmbeck, Coakley & Franks (2004) that a moderator variable influences the strength or direction of a relationship between a dependent variable and an independent variable. In addition, result of test of H₃ supports the position of Agbejule (2011).

The path diagram for the moderation model is presented in Fig 2:

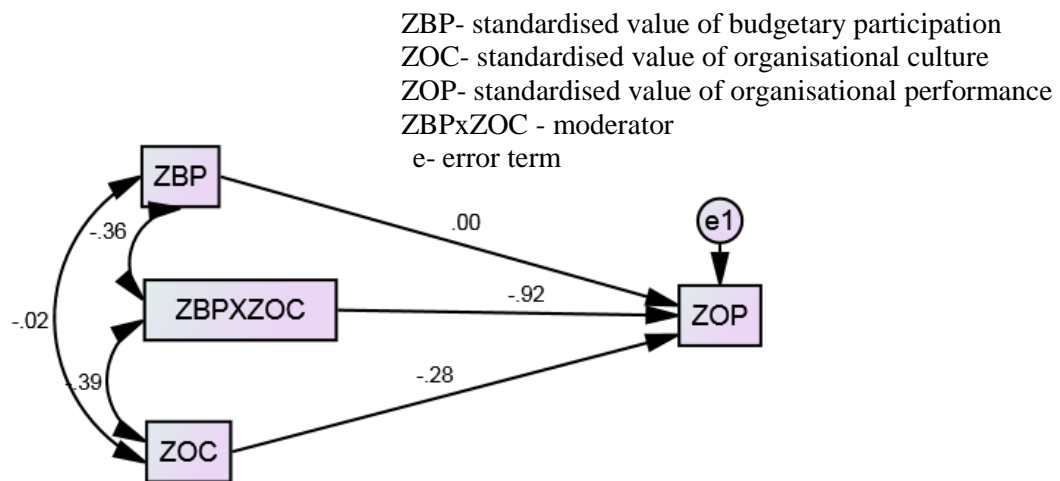

Figure 2: path diagram for moderating effect of OC using SEM

Summary and conclusion

Dwindling resources and funding from the federal government, has made the use of budgeting a veritable tool for resource managers such as heads of departments in federal universities across Nigeria. Evidence from literature has shown that the behavioural aspect of budgeting which revolves around the role of humans in the budget process is paramount for achieving budget objectives as well as influence levels of performance in the organisation. Consequently, the behavioural aspect of budgeting is assumed to play a role in observed level of performance of federal universities in Nigeria.

Inconsistent findings in the relationship between budgetary participation and organisational performance have necessitated studies to introduce effect of endogenous or exogenous variables into such relationships. As such organisational culture was adopted as an exogenous factor which interacts with budgetary participation, to explain observed performance among federal universities in Nigeria.

This study relied extensively on primary data, which was gathered by administering questionnaire to heads of departments and units across federal universities in Nigeria. Multi-stage sampling was adopted in selecting the respondents. A combination of descriptive and inferential tools of statistical analysis was adopted. Inferential analysis was performed using structural equation modelling. Results of data analysis showed all the sampled universities had a predominant internally focused organisational culture, except for one university. Budgetary participation was moderate among all the sampled institutions, while organisational performance was observed to be good and very good. There is empirical support for that conclusion that organisational culture did moderate the effect of budgetary participation of organisational performance.

References

Agbejule, A. (2011). Organizational culture and performance: The role of management accounting system. *Journal of Applied Accounting Research*, 12(1), 74-89.

Ahmed, R. (2002). *Behavioral management accounting*. Quorum Books, Westport, USA

Amat, J.M. (1991). Los sistemas de conteol en empresas de alta tecnología: el caso de dos empresas del sector químico-farmacéutico, ICAC, Madrid. Retrieved from www.eurojournals.com/ibba_7_04.pdf

Anderson, S. W. & Lillis, A. M. (2011). Corporate frugality: Theory, measurement and practice. *Contemporary Accounting Research*, 28(4), 1349-1387.

Baker, A.K. (2002). *Organizational culture*. Retrieved from <http://www.au.af.mil>

Bogt, H. J. & Scapens, R.W. (2011). *The management of performance in universities - npm and some of its effects*. Paper presented at the EGPA conference, Bucharest, Romania. Retrieved from <http://egpa-conference2011.org/documents/PSG2/Bogt-Scapens.pdf>

Cameron, K., & Michigan, A. A., (2004). *A process for changing organizational culture*. Retrieved from <http://www.competingvalues.com>

Deal, T. E., & Kennedy, A. A., (1982), *Corporate Cultures: The Rites and Rituals and Corporate Life*, Harmondsworth: Penguin Books.

DeBusk, K.G., Brown, M.R. & Killough, N.L. (2003). Components and relative weights in utilization of dashboard measurement systems like the balanced scorecard. *The British Accounting Review*, 35(3),215-231

Ehtesham, M., Muhammad, M.T., & Muhammad, A.S. (2011). Relationship between Organizational Culture and Performance Management Practices: A Case of University in Pakistan. *Journal of Competitiveness*, 4, 78-86

Furnham, A. & Gunter, B. (1993). *Corporate assessment: Auditing a company's personality*. London: Routledge.

Henri, J. F. (2006). Organizational culture and performance measurement systems. *Accounting Organization and Society*, 30, 77-103

Huang, Q., Fang, K. & Liu, H. (2013). The Moderating Role of Organizational Culture in the Relationship between Power, Trust, and eSCMS Adoption Intention. *PACIS 2013 Proceedings*. Paper 213. Retrieved from <http://aisel.aisnet.org/pacis2013/213>

Hughes, C. (2008). *Introduction to participatory budgeting*. Retrieved from <http://rossendale.gov.uk>

Kaplan, R. S. & Norton, D. P. (1992). The balanced scorecard – measures that drive performance. *Harvard Business Review* (Jan – Feb), 71 – 79.

Lu, C. T., (2011). Relationships among budgeting control system, budgetary perceptions, and performance: A study of public hospitals. *African Journal of Business Management*, 5(15), 6261-6270

Mah'd, O., Al-Khadash, H., Idris, M., and Ramadan, A., (2013). The Impact of Budgetary Participation on Managerial Performance: Evidence from Jordanian University Executives. *Journal of Applied Finance & Banking*, 3(3), 133-156

Mahfar, R. & Omar, N. (2004). The Current State of Management Accounting Practices in Selected Malaysian Companies: An Empirical Evidence. Universiti

Tenaga Nasional *International Business Management Conference*, 50-61.
Retrieved from <http://dspace.uniten.edu>.

Maiga, S. A., & Jacobs, A.F. (2007). The Relationship between Budgetary Participation and Managerial Performance: The Role of Trust and Budget Goal Commitment. *The Southern Business & Economic Journal*, 30, (3 & 4), 2-48

Merchant, A. K. (1981). The design of the corporate budgeting system: influence on managerial behaviour and performance. *The Accounting Review*, 56 (4), 813 – 829.

Mustahpha, A.N. & Ghani, K.E. (2013). Risk management in budgetary management accounting practices in Malaysian's construction companies. *Asian Journal of Business and Management Sciences*, 2(9), 1-16

Ng'ang'a, M.J. & Nyongesa, J.W. (2012). The Impact of Organisational Culture on Performance of Educational Institutions. *International Journal of Business and Social Science*, 3(8), 211-217

Noor, M.I. & Othman, R. (2012). Budget participation: How it affects performance and commitment. *Accountancy Business and the Public Interest*: 53-73.

Omolehinwa, E., (1989). PPBS in Nigeria: Its origin, progress and problems. *Public Administration and Development*, 9, 395–404.

Ouchi, W.G. (1981). *Theory Z*. Reading, MA: Addison – Wesley.

Raghunandan, M., Ramgulam, N., & Raghunanda-Mohammed, K. (2012). Examining the Behavioural Aspects of Budgeting with particular emphasis on Public Sector/Service Budgets. *International Journal of Business and Social Science*, 3(14), 110-117

Rajendar, K.G. & Jun Ma (2005). Benchmarking Culture and Performance In Chinese Organizations, *Benchmarking: An International Journal*, 12(3), 260-274.

Rose, M.B., Holmbeck, N.G., Coakley, M.R. & Franks, A.E. (2004). Mediator and Moderator Effects in Developmental and Behavioral Pediatric Research. *Developmental and Behavioral Pediatrics*, 25(1), 58-67

Schein, E. H. (1993). How Can Organizations Learn Faster? The Challenge of Entering the Green Room. *Sloan Management Review*, 34, 85-92.

Schimmoeller, J.L. (2010). Leadership styles in competing organizational cultures. Kravis leadership institute. *Leadership Review*, 10(summer), 125-141.

Seaman, A.E, Landry Jr., R and Williams, J.J. (2011). Budget related behavior: Resolving a portion of the performance puzzle in the management accounting system. *The review of Accounting Information Systems*, 4(1), 51-68

Sejjaaka, S. (2010). Work values and inductance of accounting information in an emerging market. *Makerere Business Journal*, 10 (1), 54-75

Shahzad, F., Luqman, R. A., Khan, A. R., & Shabbir, L. (2012). Impact of Organizational Culture on Organizational Performance: An Overview. *International Journal of Contemporary Research in Business*, 3(9), 975-985.

Silva, L.M.D & Jayamaha, A. (2012). Budgetary Process and Organizational Performance of Apparel Industry in Sri Lanka. *Journal of Emerging Trends in Economics and Management Sciences (JETEMS)* 3(4), 354-360

Subramaniam, N. & Mia, L. (2003). A note on work-related values, budget account. *Management Accounting research*, 14(4),389-408

IMPACT OF KNOWLEDGE OF FORENSIC ACCOUNTING SERVICE ON FRAUD PREVENTION IN THE NIGERIAN PUBLIC SECTOR

By

Ahmad Imam, PhD
Department of Accounting,
University of Maiduguri
idadinibm@yahoo.com
07030351171

Ahmed Modu Kumshe, PhD, FCA
Department of Accounting,
University of Maiduguri
amkumshe@gmail.com
07033278606

&

Musa Garba Gulani
Department of Accounting,
University of Maiduguri
musagln@yahoo.com
07031019525

IMPACT OF KNOWLEDGE OF FORENSIC ACCOUNTING SERVICE ON FRAUD PREVENTION IN THE NIGERIAN PUBLIC SECTOR

ABSTRACT

This study assessed the knowledge of Nigerian public sector accountants on forensic accounting service. It determined their level of awareness as to the use of forensic accounting service for fraud prevention in public sector. The research employed survey research design. Primary data were obtained from 363 returned questionnaires administered on public sector accountants in Nigeria using purposive random sampling. The data obtained were analysed using descriptive statistics and independent t-test. The analysis of the data

revealed that there is no significant knowledge of forensic accounting in the Nigerian public sector. Therefore, forensic accounting is not put into service since most of the respondents are of the opinion that it does not exist in the public sector. The study recommended that forensic accounting be introduced in the public sector and let it be statutory, so that routine investigations can be carried on public sector accounts to prevent fraudulent financial services.

Keywords: Forensic Accounting, Forensic Accountants, Fraud Prevention, public Sector Accountants.

Introduction

Forensic accounting is a specialized field of accounting which deals with legal claims and complaints. It is concerned with investigative and litigation support. Those who provide the services of forensic accounting are called Forensic Accountants; they are also called in some instances as forensic audits or detector accountants and are bound to provide other specialists with required evidence in law courts. Any accountant, especially in employment of a law court, plays a role like as a forensic physician but being in employment of a firm of forensic accounting appears as an agency. Forensic Accountant is an agent who is familiar with financial accounting, auditing and legal problems acting as a referee, expert, inspector or proxy especially in financial claims and cases of financial fraud.

In other words, forensic accountants are considered as experienced auditors, accountants and inspectors of legal and financial documents who are employed to investigate fraudulent activity and prevent it. They also provide some services in accounting, damages and valuation of financial records.

The role of auditors in fraud detection and prevention has been questionable (Bhasin, 2013). This is due to the rise in financial scandals at the beginning of the twenty-first century associated with increased fraud incidence and knowledge. Hogan et al (2008) argued that the rise and rate of occurrence of financial fraud has not shown any decline since the Sarbanes-Oxley Act was passed in 2002. Hence, there is need to respond to these modern organised frauds through forensic accounting services. This has prompted a paradigm shift in accounting education and service (Gray and Moussalli 2006; Eiya and Otalor 2013).

One of the major factors dwindling the Nigerian economy according to (Jeremiah, 2006) is fraud in public and private sector. According to Hamilton and Gabriel (2012) as cited by (Effiong, 2013) “fraud and related ills have caused instability in the economy resulting to a high mortality rate of business organisations and the consequent losses of revenue” in Nigeria. This places a demand for forensic accountant. Forensic accounting service in Nigeria is largely considered to be at its infancy stage and lacking statutory support even though its relevance in unravelling complex official corruption is on the increase. (Akhidime and Uagbale-Ekatah, 2014).

The relevance of forensic accounting in unravelling fraud in Nigeria is stressed in a research conducted by (Okoye and Gbegi, 2013) in Kogi State. Their findings indicate that the use of forensic Accountants can help better in detecting and preventing fraud cases in the public sector organizations. However, the application of forensic accounting in Nigeria is still at the infancy stage (Akhidime and Uagbale-Ekatah, 2014). This may not be unconnected with the fact that many of the Nigerian public sector accountants may not be aware of forensic accounting services. This may be true because as at the time of conducting this study there is no available literature which indicates the level of knowledge of forensic accounting impact on fraud prevention in the Nigerian public service. This research therefore focuses on investigating the Public sector accountants’ knowledge of forensic accounting and its relationship with fraud prevention in Nigeria.

The study findings have important implications for understanding the relevance of forensic accounting service in Nigeria. The study is expected to conclude that a portion of the high rate of fraud in Nigerian public service could be attributable to lack of knowledge of forensic accounting services by the perpetrators. This may convince the government to adopt forensic accounting service in the country.

The study expands the literature on the forensic accounting services in Nigeria by highlighting the importance of knowledge of forensic accounting service in Nigerian public sector which hitherto not captured by previous researches. This will fill the existing gap in research on the topic.

The study asked the following questions:

- i. Are Nigerian public sector accountants knowledgeable about forensic accounting service?

- ii. Are Nigerian public sector accountants attending forensic accounting seminar, workshop or conference?
- iii. Are Nigerian public sector accountants Knowledgeable about investigative accounting?
- iv. Are Nigerian public sector accountants Knowledgeable about litigation support?
- v. Are Nigerian public sector accountants Knowledgeable about expert witness?
- vi. Is current auditing system adequate in preventing and detecting fraudulent services in the Nigerian public sector?
- vii. Is there need for alternative method of preventing fraudulent activities by Nigerian public sector accountants?

The following hypothesis was tested

Ho: Nigerian public sector accountants have no significant knowledge of forensic accounting service.

Literature Review

Ramazani and Rafiei (2010) studied the accountants' perception of prevention methods of fraud. In this research they examined accountants' perception of forensic accounting which demonstrates the low extent of accountant's perception of forensic accounting. Forensic accounting is considered as one of the factors in fraud prevention. Considering the corruption rating of Nigeria by international organisation like the Transparency International, and even the local believe on fraudulent financial services, a study of forensic accounting in Nigeria is very much relevant to curtail the act of fraudulent financial services.

KPMG's Fraud Survey (2003) reveals that more companies are recently experiencing incidents of fraud than in prior years; taking measures to combat fraud; and launching new antifraud initiatives and programs in response to the Sarbanes-Oxley Act of 2002 (KPMG 2003). PricewaterhouseCoopers' (PWC) 2003 Global Crime Survey indicates that 37 per cent of respondents in 50 countries reported significant economic crimes with the average loss per company of \$2,199, 930 (PWC 2003). These survey results underscore the importance of forensic accounting service and education. Prior research (Rezaee 2002; Crumbley 2001; Peterson and Reider 1999, 2001; Rezaee et al. 1996; Rezaee and Burton 1997) reviewed the literature on forensic accounting services, certifications, and education.

These studies also provide evidence indicating that forensic accounting education has evolved from being limited, to continuing professional education sessions for practicing accountants, to a current state of being offered as a credit course by several universities. Buckhoff and Schrader's (2000) study finds, "adding a forensic accounting course to the accounting curriculum can greatly benefit the three major stakeholders in accounting education—academic institutions, students, and employers of accounting graduates." All these studies were carried in the international scene.

Prior related studies can be classified into groups. Among the groups is that study which examined course syllabi to determine the coverage of forensic accounting including fraud investigation education. Groomer and Heintz (1994) analysed the topics covered in internal auditing courses in the United States and Canada and found that fraud related topics were taught in more than 31 per cent of examined internal auditing courses. Rezaee et al. (1996) examine the coverage of forensic accounting in the accounting curriculum and found that only a handful of universities offer a fraud and/or forensic accounting course, and suggest that the accounting curriculum provide a knowledge acquisition base in forensic accounting as part of curriculum changes in response to the mandated American Institute of Certified Public Accountants (AICPA) 150- hour accounting program. Peterson and Reider (2001) review forensic accounting course syllabi of universities and analyse the level of course offering, learning objectives, content of forensic accounting courses, and course requirements. Evidence available even on the net indicates that forensic accounting in the academic and professional service is gaining prominence and recognition as a new field. Nigeria shall not fold its arms and looking at the international scene in that sense.

Emma and Okaro (2011), in their research concentrated on the perception of Accounting Academics on the vexed issues of Forensic Accounting techniques. A survey research design approach was adopted for their study. Questionnaire was administered on Accounting Academics of 8 tertiary institutions in the Eastern part of Nigeria. The study revealed, from the perception of Accounting Academics, that Forensic Accounting techniques injected in an audit and given cost/benefit considerations is capable of increasing the ability of the Auditor to detect fraud and thus help bridge the audit expectation gap in Nigeria. They concluded that this finding has implications for both accounting education and accounting service. Yet quick

glances at the course outline of tertiary institutes in Nigeria do not reflect forensic accounting as a course or even as a subject despite its importance in preventing or detecting financial fraud.

Theoretical framework

Deterrence Theory

The deterrence theory of punishment can be traced to the early works of classical philosophers such as Thomas Hobbes (1588–1678), Cesare Beccaria (1738–1794), and Jeremy Bentham (1748–1832). (Andenaes, 1974)

According to deterrence theory, the awareness of a punishment will prevent people from performing the behaviour. This can be accomplished either through punishing someone immediately after the undesirable behaviour so that they are reluctant to perform the behaviour again or through educating people about the punishment pre-emptively so they are reluctant to perform the behaviour at all. In a management context, punishment tools can include demotions, salary cuts, and terminations (fires).

Deterrence theory says that people don't commit crimes because they are afraid of getting caught but by being motivated by some deep moral sense. People are most likely to be dissuaded from committing a crime if the punishment is swift, certain and severe. For example, in the candy bar theft, if there is a low likelihood that you'll get caught or if the punishment for getting caught is just a warning, deterrence theory says you'll be more likely to steal it.

In the same vein, there is high probability that a fraudulent accountant will be dissuaded from committing fraud if he knows that he may be jailed by doing the act. The act of punitive measures taken on fraudulent accountants is what forensic accounting service is all about. Therefore, for accountants to shun away easily from committing fraud, they should be knowledgeable of the forensic accounting service. This has the implication of preventing frauds in the country.

Research Methodology

The research methodology used in this study is based on survey method. Research questions were adapted from the Nigeria Institute of Forensic accountants' daily questions and modified for this study. A survey questionnaire was completed by the Nigerian public sector Accountants who were purposively selected at random from federal ministry of finance. The data was collected at a point in time in 2014 within a period of two weeks. The questionnaire contains seven close ended questions. The result is presented in the descriptive statistics and hypothesis was tested using independent t test with the aid SPSS version 20.

The Results and Analysis

The results and analysis of the field survey are presented in Tables 1 as descriptive statistics.

Table 1 Awareness of forensic accounting services

Question Statements:	Yes	No	TR
i. Knowledge of forensic accounting from school, friends and personal reading	108 (29.8%)	255 (70.2%)	363 (100%)
ii. Attended forensic accounting seminar, workshop or conference	173 (47.7%)	190 (52.3%)	363 (100%)
iii. Knowledge of investigative accounting	98 (27.0%)	265 (73.0%)	363 (100%)
iv. Knowledge of litigation support	173 (47.7%)	190 (52.3%)	363 (100%)
v. Knowledge of expert witness	179 (49.3%)	184 (50.7%)	363 (100%)
vi. Current auditing system is adequate in preventing and detecting fraudulent services in the Nigerian public sector	170 (46.8%)	193 (53.2%)	363 (100%)
vii. There is need for alternative method of preventing and detecting	186	177	363

fraudulent services in the Nigerian (41.2%) (48.8%) (100%)
public sector

Source: 2014 Field Survey.

Note: (i) TR= Total Response

From Table 1, it can be seen that respondents did not share the same opinion. For question one, a total of 255 "No" and 108 "Yes" responses are presented representing 70.2% and 29.8% respectively. The implication of this is that there are more Accountants in the Nigerian public sectors who have no knowledge of forensic accounting than those who have. Similarly, in question two, a total of 190 respondents indicates "No" responses representing 52.3% of the total responses and 173 respondents say "Yes" representing 47.7%. This result indicates that accountants and auditors are not attending trainings in forensic accounting.

Analysis of question three revealed 265 public sector accountants representing 73% have no knowledge of investigating accounting against 98 responses representing 27% of the total responses. This also indicates that there are fewer accountants who have knowledge of investigative accounting than those who have not. In the same vein, question four had 190 "No" responses representing 52.3% and 173 "Yes" representing 47.7%. This implied that more respondents are not knowledgeable of litigation support compare to those who have. Question five revealed that a total of 184 respondents, representing 50.7% responded "No" and 179 "Yes" representing 49.3 been recorded in. This indicates that there are more respondents who are not knowledgeable of expert witnessing than those who are knowledgeable. The implication is that public sector accountants cannot provide authoritative evidence in court of law.

Furthermore, question six had a total of 170 "Yes" responses representing 46.8% and 193 "No" responses representing 53.2%. The implication is that there is need to reorganise the system of financial fraud prevention measures in the Nigeria public sector. Question seven had 186 "Yes" responses indicating 51.2% and 177 "No" representing 48.8%. The implication is that there is the need to review the process of preventing financial fraud in the Nigeria public sector.

In summary, the calculated overall mean is 0.58 which is over the actual mean of 0.5 and based on this preliminary stage, it can be established that Nigerian public sector accountants have no knowledge of forensic accounting service.

Given the diverse views of public sector accountants on the knowledge of forensic accounting practice, the research uses independent t test to find the significant differences between the Yes and No responses of the accountants.

Hypothesis Testing

Ho₁: Nigerian public sector accountants have no significant knowledge of forensic accounting service.

In order to test the hypothesis, responses from question one was drawn as the hypothetical data.

Table 2 Result of differences of the respondents' knowledge of forensic accounting service

	Levene's Test for Equality of Variances		t-test for Equality of Means						
	F	Sig.	t	df	Sig. (2-tailed)	Mean Difference	Std. Error Difference	95% Confidence Interval of the Difference	
								Lower	Upper
Equal variances assumed	6.021	.070	-1.716	4	.161	-49.00	28.560	-128.295	30.295

Source: SPSS Version 20 generated result.

Table 2 shows an independent-samples t-test comparing the differences in responses between "Yes" and "No" responses of Nigerian public sector accountants. The result reveals (t at $df(4) = -1.716$, $p = .161$, two tailed). The p indicates greater value than alpha (0.05) this indicates no significant difference between the groups. As such the hypothesis which says Nigerian public sector accountants have no significant knowledge of forensic accounting service is therefore accepted.

Research Result and Findings

This research provided the results of survey research obtained From 363 Nigerian public sector accountants; descriptive statistics and independent t test results indicate that the accountants have no knowledge of forensic accounting service. This means the result of the tested hypothesis corroborate the result of descriptive statistics.

The findings of this research concur with the study conducted by Morteza and Hossein (2010) where accountants' perception of forensic accounting as a preventive method of fraud was examined. The findings of that study reveals low extent of accountant's perception of forensic accounting. Furthermore, to consolidate the findings of this research, it was argued that the application of forensic accounting in Nigeria is at its infancy stage (Akhidime and Uagbale-Ekatah, 2014).

Recommendation

The Office of the Auditor-General for the federation suppose to be free from interference by any arm of the government of the federation. It shall be independent and can source for more capable staff and allow for independence of the public sector audit department so that adequate supervision of accounting controls can be made to prevent financial fraud.

Furthermore audit staff shall have training at least once in a year so that they are updated on current issues on forensic accounting and auditing. This can be achieved by providing for training funds in the budget and liaising with the professional accounting bodies and tertiary institutes both locally and internationally for training.

Forensic accounting body be established by the presidency in consultation with the professional accounting bodies and backed up by statute from the

national assembly. The body shall check all public sector accounting controls without notice, shall be independent and its report made public with a copy to all the arms of the government. This will assist in eradicating or reducing the level of fraudulent activity in the public sector through its investigative and litigation support.

References

- Akhindime, A.E., and Uagbale-Ekatah, R.E. (2014) The Growing Relevance of Forensic Accounting as a tool for Combating Fraud and Corruption: Nigeria Experience. *Research Journal of Finance and Accounting*, 5(2), 71-77
- Andenaes, J. (1974). *Punishment and deterrence*. Ann Arbor: University of Michigan Press.
- Bhasin, M. (2013) Survey of skills required by forensic accountants: evidence from a developing country. *International Journal of Contemporary Business Studies*, 4 (2), pp.54 – 86.
- Buckhoff, T. A., & Schrader, R. W. 2000. The teaching of forensic accounting. *Journal of Forensic Accounting*, 1.1, 135–146.
- Crumbley, D. L. 2001. Forensic accounting: Older than you think. *Journal of Forensic Accounting*, 11.2, 181–202.
- Efiong, E.J. (2013) An Exploration of Forensic Accounting Education and Practice for Fraud Prevention and Detection in Nigeria. A PhD thesis submitted to the Faculty of Business and Law, De Montfort University, Leicester.
- Eiya, O., and Otalor, J. I. (2013) Forensic Accounting as a Tool for Fighting Financial Crime in Nigeria. *Research Journal of Finance and Accounting*, 4(6), pp.18-25.
- Emma, I. O. & Okaro, S. C. (2011). Forensic Accounting and Audit Expectation Gap – The Perception of Accounting Academics. Retrieved from <http://ssrn.com/abstract=1920865>. 21/04/2012

- Gray, D. (2008) Forensic accounting and auditing: compared and contrasted to traditional accounting and auditing. *American Journal of Business Education*, Fourth Quarter, 1 (2), pp. 115 – 126.
- Groomer, S. M., & Heintz, J. 1994. A survey of advanced auditing courses in the United States and Canada. *Issues in Accounting Education*, 9.1 (Spring), 96–108.
- Hamilton, D. I., & Gabriel, J. M. O. (2012). Dimensions of fraud in Nigeria quoted firms. *American Journal of Social Management Sciences*, 3(3), 112-120.
- Harrison, J.L. (2001). Reconceptualizing the Expert Witness: Social Costs, Current Controls and Proposed Responses. *Yale Journal on Regulation*. 18, 253, 1-46.
- Hogan, C.E., Rezaee, Z., Riley, R.A. and Velury, U.K. (2008) Financial statement fraud: insights from the academic literature. *Auditing: A Journal of Practice and Theory*, 27 (2), pp. 231-252.
- James L. B. Richard G. B. & Carl, P. (2006). "Accountants" perceptions regarding fraud detection and prevention methods", *Managerial Auditing Journal*, Vol. 21 No. 5.
- Jeremiah, M. (2006) Nigerian dwindling economy. *Journal of Business Research*. 11, pp 26-30.
- KMPG Forensic. (2003). *Fraud Survey 2003*. Montvale, NJ.
- Okaro, S. C. (2011). The Relevance of Statutory Audit, *Journal of Global Accounting*, Vol. 1(2): 21-28. Retrieved from <http://ssrn.com/abstract=1730705>. 9/07/2012
- Okoye, A.E. and Jugu, Y.G. (2009) Effectiveness of fraud deterrence policies: a critical examination of the banking sector in Nigeria. *The Nigerian Accounting Horizon*, 8 (5), pp. 154 – 169.

- Pedneault, S. (2009). *Fraud 101 Techniques and Strategies for Understanding Fraud*. John Wiley & Sons Inc. Hoboken, NJ.
- Peterson, B. K., & Reider, B. P. (1999). Fraud education of accounting students: A survey of accounting educators. *The National Accounting Journal*, Winter, 23–30.
- Peterson, B. K., & Reider, B. P. (2001). An examination of forensic accounting courses: Content and learning activities. *Journal of Forensic Accounting*, 2.1, 25–42.
- PricewaterhouseCoopers (PWC). (2003). *Global economic crime survey 2003*. Available at <http://www.pwc.com/extweb/ncsurvers.nsf>.
- Ramazani, M. & Rafiei, A. H. (2010). Iranian Accountants Conception of the Prevention Methods of Fraud and Offering Some Recommendations To Reduce Fraud In Iran. *Global Journal of Management and Business Research*, 10 (6), 31-45.
- Rezaee, Z. (2002). Forensic accounting services, education, and certifications. *Journal of Forensic Accounting*, 3.2, 207–223.
- Rezaee, Z., & Burton, E. J. (1997). Forensic accounting education: insights from academicians and certified fraud examiner practitioners. *Managerial Auditing Journal*, 12 (9), 479–489.
- Rezaee, Z., Reinstein, A., & Lander, G. H. 1996. Integrating forensic accounting into the accounting curriculum. *Accounting Education*, 1 (2), 147–162.

FISCAL RESPONSIBILITY ACT (FRA) AND ITS IMPLICATIONS ON THE PERFORMANCE OF PUBLIC SECTOR ACCOUNTANTS

By
Kolawole, Peace. E.

Department of Accounting
Faculty of Social and Management Sciences
Bowen University, Iwo, Osun State

Tel: +2347062325380 **E-mail: peacekolawole2@gmail.com**

Abstract

This study assessed Fiscal Responsibility Act (FRA) and its implications on the performance of public sector accountants. It enunciated the challenges which led to the enactment of FRA, some of which were mismanagement of oil windfalls, existence of poor savings culture, a badly fragmented budgetary system and poor accountability. It considered the effect of Fiscal Responsibility Act on the budgetary role performed by the public sector accountants. It also evaluated accountability and transparency in the profession, in relation to the Fiscal Responsibility Act. A structured questionnaire was used to gather data from 104 public sector accountants in the Federal ministries and institution in Ibadan metropolis as regards their perception of the FRA provisions on their budgetary roles. Correlation analysis was used to test the degree of relationship existing between the variables. Findings revealed that the financial projections put in place in the Medium Term Expenditure Framework (MTEF) by FRA have aided budget preparation, implementation and monitoring. Oil prices and tax revenue projections were also less than accurate and public debts were not effectively managed.

This study contributes to the literature, providing empirical information on FRA and its implications on the performance of public sector accountants. Funds should be monitored to ensure that that they are used for the purpose for which they are disbursed while other tiers of government should also be made to enact and enforce the implementation of FRA.

Keywords: Fiscal Responsibility Act (FRA), Medium Term Expenditure Framework (MTEF), Accountability and Transparency.

Word count: 231

1.0 Introduction

The accounting profession is made up of institutions, bodies, agencies who are guided by certain laws, rules and regulations to ensure the prudent management of resources. Some of these laws, rules and regulations include: Constitution of the Federal Republic of Nigeria, 1999; Finance (Control and Management) Act of 2004 as amended and Audit Act of 2004 as amended.

Despite the fact that there are laws, rules and regulations formulated overtime, the nation's resources appears not to be well managed. Industries are dying, there are no foreign investments, unemployment is on the increase and kidnapping has become the order of the day. All these result from unfaithfulness in the implementation of budget. Challenges arising from the management of resources in Nigeria over the years have led to the enactment of the Fiscal Responsibility Act (FRA) of 2007 by the National Assembly. The Chairman, Fiscal Responsibility Commission, Yelwa, (2012) identified some reasons which have steered the enactment of FRA; some of which include: mismanagement of oil windfalls, subsisting fiscal environment being generally dysfunctional, existence of a poor savings culture, poor accountability and a badly fragmented budgetary system. He noted that the above reasons resulted into economic volatility, inefficient public sector investments, debt overhang, poor service delivery and worsening socio-economic conditions of citizens.

Thus, the Fiscal Responsibility Act was established to provide for prudent management of the Nation's resources, ensure long-term macro-economic stability of the national economy and secure greater accountability and transparency in Fiscal operations within a Medium Term Fiscal Policy Framework. (Due Process Handbook, 2007) These are to be superintended by the Fiscal Responsibility Commission which ensures the promotion and enforcement of the national goal. In essence, the FRA entails economy, efficiency and effectiveness in the use of government's funds. The

accounting profession is relied upon by the FRA to ensure accountability and transparency which are the hallmark of the Act.

Therefore, this study seeks to assess FRA and its implications on the performance of public sector accountants. It will also find out to what extent the public sector accountants have made use of the provisions given in the FRA in performing their budgetary roles. This also seeks to understand how prudent financial management of government resources and the enhancement of fiscal performance of the government as a whole are achieved.

2.0 Statement of Problem

The Nigerian society is filled with stories of wrong practices such as stories of ghost workers on the pay roll of ministries, extra-ministerial departments and parastatals, frauds, embezzlements, setting ablaze of offices housing sensitive documents and corruption are found everywhere in the country (Okwoli, 2004). Billions of Naira is lost in the public sector every year through fraudulent means (Onuorah and Appah, 2012). Appah and Appiah (2010) argues that cases of fraud is prevalent in the Nigerian public sector and that every segment of the public service seems to be involved one way or the other in some of these unconventional fraudulent acts. In order to proffer solution to the challenge of mismanagement of government resources, the Fiscal Responsibility Act was enacted. This study therefore examines FRA and its implications on the performance of public sector accountants, in particular, the budgetary functions. It will also provide insight into the challenges faced by public sector accountants which may prevent them from adequately making use of the Act. Although, previous studies have addressed the Performance of Fiscal Responsibility Legislations in African economies (Achua, 2009); Institutionalisation of the Medium Term Expenditure Framework (MTEF) in the Fiscal Governance of Nigeria (Leading Edge Academy, 2010), Debt Management in Nigeria (Yelwa, 2010); yet an in-depth study which addresses the Fiscal Responsibility Act (FRA) and its implications on the performance of public sector accountants has not yet being done. Hence, this study fills this gap in knowledge.

3.0 Objectives of The Study

This study seeks to assess Fiscal Responsibility Act (FRA) and its implications on the performance of the public sector accountants. Its specific objectives are to:

- i. assess the effect of Fiscal Responsibility Act on the budgetary role performed by public sector accountants.
- ii. assess the effect of Accountability and Transparency on the budgetary role performed by public sector accountants in relation to the provisions of Fiscal Responsibility Act.

4.0 Research Hypotheses

The following hypotheses are formulated for the purpose of this study:

Ho (1): Fiscal Responsibility Act has no implication for the budgetary role performed by

the accounting profession.

Ho (2): Accountants have no role in ensuring Accountability and Transparency in

Fiscal operations.

5.0 Concept of Fiscal Responsibility Act

Fiscal Responsibility Act can be defined as “an act to provide for the prudent management of the nation’s resources, ensure long-term macro-economic stability of the national economy and secure greater accountability and transparency in fiscal operations within a medium term fiscal policy framework. It provides for the establishment of the Fiscal Responsibility Commission to ensure the promotion and enforcement of the Nation’s Economic objectives; and for related matters” (Fiscal Responsibility Act, 2007).

Some authors also wrote on Fiscal Responsibility Act (FRA). They include the following:

- Achua (2009) mentioned that as a law, FRA can be broadly defined to encompass the set of rules and regulations according to which budgets are drafted, approved and implemented.
- FRA is also seen as a statutory or constitutional restriction on fiscal policy that establishes a specified limit on a fiscal indicator such as the budgetary balance, debt, spending or taxation.

5.1 Nature of Fiscal Responsibility Act

- Fiscal Responsibility reflects the increasing transparency and accountability
- Fiscal Policy is also subject to democratic oversight

- Effective and efficient fiscal responsibility enhances the provision of better-focused, value-for-money services
- Fiscal rules can also be said to be an alternative benevolent social planner.

5.2 Objectives of Fiscal Responsibility Act

The objectives of Fiscal Responsibility Act include the following:

- ❖ To ensure prudent management of the nation's resources
- ❖ To ensure macro-economic stability of the national economy
- ❖ To enhance the credibility of government's fiscal policy and also help in deficit elimination
- ❖ To promote transparency in budget preparation, execution and reporting
- ❖ To help the public have access to adequate information on the financial activities of government
- ❖ To reduce any negative externalities within a federal or international arrangement
- ❖ To propel accountability and sound financial management in government
- ❖ To provide room for long term sustainability of fiscal policy
- ❖ To enhance proper coordination of fiscal affairs among the three tiers of the Nigerian government
- ❖ To promote high standards of financial disclosure
- ❖ To set limits on the consolidated debt of the Federal, state and local governments

5.3 Provisions of The Fiscal Responsibility Act

The Act makes certain provisions, among which the following was examined:

5.3.1 The Fiscal Responsibility Commission (FRC)

1. The Commission was set up by the Fiscal Responsibility Act, 2007 to perform the following functions:
 - i. To monitor and enforce the provisions of the Act, thus promoting the economic objectives of the Nation.
 - ii. To disseminate information on standard national and international best practices which will bring about greater efficiency in the allocation and management of public expenditure, revenue collection, debt control and transparency in fiscal matters.

- iii. To undertake fiscal and financial studies, analysis and diagnosis and disseminate the result to the general public.
 - iv. To carry out any other function which goes along with the promotion of the objectives of this Act
2. The Commission shall establish and maintain a Fund from which shall be paid all expenditure incurred by the Commission. Budgetary allocations from the Federal Government and grants from other sources shall be put in the Fund.
3. The Commission shall also have power to:
 - i. formulate and provide general policy guidelines for the discharge of the functions of the Commission.
 - ii. superintend the implementation of the policies of the Commission.
 - iii. choose employees who, as may be decided by the Commission, are expedient and necessary for the proper and efficient performance of its functions.
 - iv. determine the terms and conditions of service in the Commission, which includes the disciplinary measures for the employees of the Commission.
 - v. fix the remuneration, allowances and benefits of the employees of the Commission as approved by the Salaries and Wages Commission.
 - vi. regulate its proceedings and make standing orders as to holdings of the meetings, notices to be given and keeping of minutes of its proceedings.
 - vii. perform other things necessary to ensure the efficient performance of the functions of the Commission.

However, the Act fails to mention any specific provisions regarding the penalties to be accorded anyone who does not comply with any section of the Act. For instance, Section 39 provides that any violation of the requirements of Sections 36, 37 and 38 shall be an offence, yet, not stating the penalties for such offence. It is therefore suggested that the Act needs to be straightened with firm penalties for failure to comply and also power to charge offenders to court.

Although the Act did not make provisions for penalties for non-compliance of the Act, it makes a provision in Section 51 for any person to enforce the provisions of this act by obtaining prerogative orders or other remedies at

the Federal High Court, without having to show any special or particular interest.

5.3.2 The Medium Term Expenditure Framework (MTEF)

The FRA requires the Federal government to prepare the (MTEF) through the Minister of Finance. The MTEF represents a multi-year budgeting system which covers a time frame of the following three years. It is also reviewed annually.

The contents of MTEF include the following:

- a. A macro-economic framework that sets out the macro-economic projections, for the next three years, the underlying assumption for the projections and an evaluation and analysis of the macroeconomic projections for the preceding three financial years.
- b. A Fiscal Strategy Paper which sets out:
 - i. Federal government's medium-term financial objectives.
 - ii. Federal government's medium-term policies on taxation, recurrent expenditure (for both non-debt and debt), capital expenditure, lending and investment, borrowings and other liabilities.
 - iii. Federal government's strategic, economic, social and developmental priorities for the next three financial years.
 - iv. An explanation on the financial objectives, strategic, economic, social, developmental priorities and fiscal measures of the Federal government.
- c. An expenditure and revenue framework which sets out for each of the next three financial years:
 - i. estimates of aggregate revenues for the Federation based on the pre-determined Commodity Reference Price adopted and tax revenue projections.
 - ii. aggregate expenditure projection for the Federation
 - iii. aggregate tax expenditure projection for the Federation; and
 - iv. minimum capital expenditure floor for the Federation.
- d. A Consolidated Debt Statement which sets out and describes the fiscal significance of the debt liability of the Federal Government and measures to reduce any of such liability.
- e. A statement describing the nature and fiscal significance of contingent liabilities and quasi-fiscal activities; including measures to offset the crystallization of such liabilities.

It can be seen that MTEF is first used in reconciling government needs with the resources available. It is also used in allocating money to strategic areas of importance in and outside various sectors of the economy over the medium term.

Moreover, Omolehinwa and Naiyeju (2011) explained that 'in preparing the MTEF, the Minister of Finance is expected to have inputs from some stakeholders including National Planning Commission and the CBN. The MTEF is required to be presented to the Federal Executive Council and the National Assembly (NASS) for approval not later than the end of the second quarter and August ending each year respectively. The approve MTEF is required to be made available on the FMF website, electronic and print media.' MTEF is also seen as a rolling process which occurs every year and aims at reducing the imbalance between what is affordable and what is demanded by agencies of government (Leading Edge Academy, 2010).

Aggregates Expenditure Limits

The aggregate expenditure is not expected to be more than estimated revenue plus 3% of estimated GDP. Nevertheless, the National Assembly (NASS) can raise the limit to any sustainable percentage. Raising the limit may lead to misuse of government funds.

5.3.3 The Annual Budget

1. The MTEF shall be the basis for the preparation of the annual budget.
2. The sectoral and compositional distribution of the estimates of expenditure shall be consistent with the medium term development priorities set out in the MTEF.

The annual budget must be accompanied by:

- a. a copy of the underlying revenue and expenditure profile for the next two years.
- b. a report which sets out actual and budgeted revenue, expenditure and detailed analysis of the performance of the budget for the 18 months up to June of the preceding financial year.

5.3.4 Transparency and Accountability

The Federal government shall ensure that its fiscal and financial affairs are conducted in a transparent manner which ensures full and timely disclosure and wide publication of all transactions and decisions involving public revenues, expenditures and their implications for its finances. This provision

therefore ensures transparency and accountability especially full and timely disclosure of government transactions.

6.0 Theoretical Framework

This study shall be based on the macro-economic framework. This is because it provides the basis for which public expenditures can be allocated over the medium term. This framework also sets the context for which major budget issues relating to revenues, expenditures and the financing of the budget deficit can be carried out. Moreover, it supports the act under review (the Fiscal Responsibility Act) which deals with the prudent management of the nation's resources, ensuring long-term macro-economic stability and securing accountability and transparency in Fiscal operations within the Medium Term Fiscal Policy Framework.

Macro-Economic Framework in Nigeria

In the medium term, government plans to continue to play active role in providing stimulus to the economy as often as necessary. Although, deficits in revenue have resulted in a downward revision of 2010 fiscal framework estimates and the budget and the level of outlay on specific expenditure heads in the budget estimates, government will continue to direct spending on projects with prior importance, especially in the area of infrastructure.

It is also expected that economic growth will continue to be driven by the non-oil sector, over the medium term. Nevertheless, a structural shift in the economy should take place as various sectors such as the manufacturing, telecommunications, retail trade and wholesale sectors in the economy increase their contribution to GDP growth. Also, diversification of the economy will be enhanced through investments in critical infrastructure and a continued focus on promoting macro-economic stability. Improvement in the oil and gas production will also add to growth and may have positive impact on other emerging sectors.

The Medium Term Expenditure Framework (MTEF) and the Fiscal Strategy Paper (FSP) are statutory documents which articulate government's revenue and spending plan as well as its fiscal policy objectives over the period. Organisations for Economic Cooperation and Development (OECD) countries are discovered to have low GDP growth figures over the last few years and there has been the occurrence of high unemployment figures. Although

Nigeria is expected to lead the recovery in the medium term, increase in the prices of food items and other commodities has been the experience. The Nigerian economy has however, recovered from the worst effects of the global economic crisis while global economic activities especially the international oil prices is still a source of concern. Oil prices have also been above \$100 per barrel since February 2011 while weak economic growth prospects pose a serious challenge to the global demand for oil.

In order to provide a solution to this, government is expected to continue to adopt the fiscal consolidation policy as from 2011 fiscal year. Also, greater coordination between monetary and fiscal authorities is required. (Citations from 2012 -2015 Medium Term Expenditure Framework & Fiscal Strategy Paper and 2010-2012 Medium Term Expenditure Framework.)

7.0 Methodology

This study employed the descriptive research form of design while Convenient sampling technique was used to obtain data from a sampled population of accountants in the public sector corporations, agencies and institution. The primary source of data collection was employed as responses were obtained from 104 respondents in the public sector in Ibadan metropolis as regards their perception of the implications of FRA on the performance of Public Sector Accountants. The percentage of frequency to which each variable is chosen was used to measure the degree of relationship between them while correlation analysis was used to test the degree of relationship existing between the variables. The result obtained helped to determine FRA and its implications on the performance of public sector accountants.

8.0 Data Analysis and Discussion

8.1 Budget Preparation

As at the moment, a 4-year capital project plan starting from 2012 is being implemented by the Nigerian government to ensure that we move away from the current portfolio of ongoing projects. The 2012 – 2015 Fiscal Strategy Paper (FSP) and MTEF have been prepared having in mind global economic uncertainty. The ever increasing risks to economic growth have also been considered in its preparation. The areas of priority identified by the government will receive the bulk of capital allocations over the period. Government intends to continue to implement a fiscal consolidation policy especially in view of the structure of expenditure which has a record of

increasing recurrent expenditure in recent times. The Medium Term Fiscal Framework is thereby given below:

Table 8.1
2012 -2015 Medium Term Fiscal Framework

FISCAL ITEMS	2011 Budget Amendm ent	2012 Projectio n	2013 Projectio n	2014 Projectio n	2015 Projectio n
	₹ bns	₹ bns	₹ bns	₹ bns	₹ bns

KEY PARAMETERS, ASSUMPTIONS & INDICATORS					
	75.00		75.00		
Average Budget price per barrel (in US\$)	150.00	75.00	150.00	75.00	75.00
Average Exchange Rate (NGN/US\$)	2.300	150.00	2.550	150.00	150.00
Oil Production (mbpd)		2.480		2.575	2.600
GROSS COLLECTIBLE REVENUE	9,152.25		10,604.3		11,923.6
FEDERALLY	6,815.45		9	11,271.2	0
REVENUE	<	9,905.64	7,006.24	9	7,272.37
Total Oil & Gas Revenue	2,151.27	6,896.04		6,953.08	
Total Non-Oil	93.62	2,741.15	3,300.31	3,998.48	4,329.15
Special Levies for Targeted Expenditure	91.91	164.67	187.07	209.06	211.33
Other Non-Federation Account Items - Education Tax		103.77	110.77	110.66	110.74
	3,241.36				
SUMMARY OF FAAC & VAT POOL	<<<		3,671.78		4,088.97
FGN STATES	1,957.46	3,462.84		3,851.18	
LGCs			2,255.15		
Total	1,482.89	2,083.13	1,705.75	2,460.74	2,631.55
	6,681.71	1,578.66	7,632.68	1,854.67	1,982.15
		7,124.63		8,166.59	8,702.67
FGN BUDGET REVENUE (INFLOWS)	120.00				
Unspent balance from precious FY	2,882.08	100.00	100.00	100.00	100.00
FGN BUDGET Share of Federation Account (48.5%)	103.50	2,882.08	3,252.49	3,380.32	3,582.89
FGN BUDGET Share of	228.93	107.90	129.71	167.56	184.14

VAT (14%)		393.46	480.81	515.89	528.04
FGN Independent Revenue	13.61				
Estimated Balances of Special Accounts end Dec.	FGN's	<u>3,348.12</u>			
		<u>3,693.17</u>	<u>3,970.14</u>	<u>4,171.77</u>	<u>4,403.86</u>
Total					
		<u>3,348.12</u>			
		<u>3,693.17</u>	<u>3,970.14</u>	<u>4,171.77</u>	<u>4,403.86</u>
FEDERAL GOVT. OF NIGERIA BUDGET	>>				
FGN REVENUE (INFLOWS)		<u>417.82</u>	<u>345.72</u>	<u>344.44</u>	<u>341.81</u>
Less		<u>495.10</u>	<u>550.01</u>	<u>4,054.61</u>	<u>4,209.98</u>
		<u>3,571.82</u>	<u>3,901.88</u>		
Statutory Transfers			<u>2,623.72</u>	<u>2,670.04</u>	<u>2,679.85</u>
Debt Service Recurrent		<u>2,425.07</u>	<u>2,581.99</u>	1,739.56	1,826.53
MDA Spending	1,506.11	1,656.72	268.05	268.05	268.05
Of which:	288.05	268.05	186.86	196.20	206.01
Non-Debt Recurrent	154.75	177.96	50.00	0.00	0.00
Personnel Costs (MDAs)	37.00	100.00	379.26	379.26	379.26
Overheads	439.16	379.26	<u>2,623.72</u>	<u>2,670.04</u>	<u>2,679.85</u>
CRF Pensions			<u>1,430.89</u>	<u>1,539.93</u>	<u>1,643.51</u>
Multi-Year Tariff		<u>1,146.75</u>	<u>1,319.89</u>		
Order			<u>4,921.55</u>	<u>5,032.49</u>	<u>5,117.89</u>
Other Service Wide		<u>4,484.74</u>	<u>4,797.61</u>	(951.41)	(714.03)
Votes	(1,136.62	(1,104.44	48,116.3	56,432.7	66,309.6
Sub-Total))	3	5	1
	38,427.0	41,101.8	-1.98%	-1.53%	-1.08%
Capital Spending	6	8			
	-2.96%	-2.69%	951.41	860.72	714.03
Aggregate Expenditure			0.00	0.00	0.00
Fiscal Deficit	1,136.62	1,104.44	0.00	0.00	0.00
GDP	0.00	0.00	50.00	50.00	50.00

DEFICIT/GDP	16.91	10.00			
	42.44	75.00	150.00	150.00	150.00
Deficit Financing					
Sales of Government Property	225.00	225.00	751.41	660.72	514.03
Privatization Proceeds	852.27	794.44	751.41	660.72	0.00
FGN's Share of Signature Bonus	852.27	794.44	0.00	0.00	0.00
Sharing from Stabilisation Fund Account (ECA)	-	,	0.00	0.00	
New Borrowings					
<i>Domestic Borrowing</i>					
<i>Foreign Borrowing</i>					
Financing Deficit/Surplus					

Source: 2012 -2015 Medium Term Expenditure Framework and Fiscal Strategy Paper

8.2 Presentation of Results

Demographic Information about respondents

The table below shows the summary of the demographic nature of respondents.

Table 8.2
Demographic Information about respondents

Variable		Percentage of Frequency (%)
Gender	Male	50.0
	Female	50.0
Official level	Lower level	10.0
	Middle level	65.0
	Top level	25.0
Working Experience	Less than 5 years	29.4
	,	31.4
	5 to 15 years	
	15 years and above	39.2

Source: Field Survey, 2012

The table 8.2 above shows that 50% of the respondents are male while 50% are female. This displays a balance distribution of gender. Also, several of the respondents are from the middle class (65%) which accounts for over half of the respondents, 25% of the respondents belong to the top level while the lowest proportion is from the lower level of accounting officers; thus representing 10% of the sampled population. The official levels represent the cadre each respondent assume in his/her work place. The top level officers are made up of the directors, managers and heads of public sector accounting department. The middle level officers are those who are

employed as accountants in each ministry or institution; while the lower level officers constitute the account clerks and IT students serving in the public sector accounting departments.

The distribution of the respondents according to their work experience was evenly distributed with respondents possessing 15 years and above, work experience having the highest percentage (39.2%). Next to this are the respondents having 5 to 15 years work experience accounting for 31.4% while the least percentage of respondents are those with less than 5 years work experience (29.4%).

8.3 Questionnaire Items frequency distribution and percentage summary of responses

The issues raised require the respondents to choose from the five options: Strongly Agree, Agree, Indifference, Disagree and Strongly Disagree. This was done in order to determine the percentage of people who strongly agreed or agreed, strongly disagreed or disagreed to the matters raised under each section. The overall objective of the questionnaire was to assess the implications of Fiscal Responsibility Act on the performance of public accountants.

Table 8.3a

Fiscal Responsibility Act and Accountants'

Budgetary Practices

Frequency distribution of Fiscal Responsibility Act (FRA) and accountant budgetary practices

Item	Strongly Agree	Agree	Strongly Disagree	Disagree	Indifference
Q.1 The financial projections put in place by the MTEF have well assisted in monitoring changes from previous years.	18(17.8%)	53(52.5%)	9(8.9%)	13(12.9%)	8(7.9%)
Q.2 The MTEF multi-year budgeting system is	8(7.9%)	45(44.6%)	15(14.9%)	21(20.8%)	12(11.9%)

being updated annually					
Q.3		14(13.6		39(37.	13(12.6
Oil prices and tax	11(10.7	%)	26(25.2	9%)	%)
revenues projections	%)		%)		
for the next three years					
are properly disclosed.					
Q.4	5(4.9%)	29(28.2		32(31.	15(14.6
Public debts are now		%)	22(21.4	8%)	%)
being efficiently			%)		
managed.					

Source: Field Survey, 2012

Fiscal Responsibility Act and Accountants' Budgetary Practices

The result in table 8.3a shows that over 70% of the respondents strongly agreed or agreed to the statement that the financial projections put in place by the MTEF have well assisted in monitoring changes from previous years and an average number of respondents of about 53% strongly agreed or agreed that MTEF multi-year budgeting system is being updated annually.

However, 63.1% of the respondents strongly disagreed or disagreed that oil prices and tax revenues projections for the next three years are properly disclosed while 53.2% strongly disagreed or disagreed that public debts are now efficiently managed.

The opinion of the respondents from the table shows that although the financial projections put in place in the Medium Term Expenditure Framework (MTEF) by FRA have helped in budget preparation, implementation and monitoring; yet oil prices and tax revenues projections are less than accurate and public debts are not duly managed.

Table 8.3b

Challenges affecting the Implementation of Fiscal Responsibility Act

Frequency distribution of challenges affecting the implementation of Fiscal Responsibility Act

Item	Strongly Agree	Agree	Strongly Disagree	Disagree	Indifference
Q.5 The Federal Government is yet to see to the enforcement of the FRA on the other tiers of government.	32(31.1%)	47(45.6%)	8(7.8%)	8(7.8%)	8(7.8%)
Q.6 Due to much government spending, the limit set over expenditure may not be adhered to.	41(39.8%)	35(34.0%)	15(14.6%)	11(10.7%)	1(1%)
Q.7 FRA has not been well adopted due to failure to appropriately spell out penalties.	28(26.9%)	44(42.3%)	15(14.4%)	10(9.6%)	7(6.7%)
Q.8 The limit set on expenditure is too narrow to be applied.	11(10.6%)	27(26.0%)	17(16.3%)	33(31.7%)	16(15.4%)
Q.9 Some provisions of the Act cannot be followed due to lack	20(19.2%)	31(29.8%)	22(21.2%)	22(21.2%)	9(8.7%)

of time limit.

Challenges Affecting the Implementation of Fiscal Responsibility Act

Table 8.3b reveals that many of the respondents (76.7%) strongly agreed or agreed that the Federal government is yet to see to the enforcement of the FRA on the other tiers of government and about 74% strongly agreed or agreed that due to much government spending, the limit set over expenditure may not be adhered to. Also, 69.2% of the respondents strongly agreed or agreed to the fact that FRA has not been well adopted due to failure to appropriately spell out penalties and about half of the respondents (50%) strongly agreed or agreed that some provisions of the Act cannot be followed due to time limit. Nevertheless, an average percentage of 48% strongly disagreed or disagreed that the limit set on expenditure is too narrow to be applied.

The table therefore shows that though the implementation of FRA has suffered challenges such as not enforcing its implementation on other tiers of government, high rate of government spending, failure to spell out penalties and lack of time limit; nevertheless, the limit set over expenditure might not be too narrow to be applied.

Table 8.3c

Accountants’ Budgetary Practices before the enactment of Fiscal Responsibility Act (FRA)

Frequency distribution of Accountants’ budgetary practices before the enactment of FRA

Item	Strongly Agree	Agree	Strongly Disagree	Disagree	Indifference
Q.10 Government financial resources are better taken care of before the enactment of FRA.	16(15.7%)	28(27.5%)	20(19.6%)	27(26.5%)	11(10.8%)
Q.11 The Accounting profession has been	13(12.5%)	41(39.4%)	27(26.0%)	20(19.2%)	3(2.9%)

effectively and efficiently disseminating information on public revenue and expenditures before FRA was passed into law.

Q.12	20(19.2	46(44.2	15(14.4	19(18.	
A well laid out basis for the preparation of budget as existed before FRA was enacted.	%)	%)	%)	3%)	4(3.8%)

Q. 13	13(12.5	23(22.1		29(27.	11(10.6
Surpluses on oil prices had always been adequately appropriated before the enactment of FRA.	%)	%)	28(26.9	9%)	%)
			%)		

Source: Field Survey, 2012

Accountants' Budgetary Practices before the Enactment of the Fiscal Responsibility Act.

It can be deduced from table 8.3c that about 52% of the respondents strongly agreed or agreed that the accounting profession has been effectively and efficiently disseminating information on public revenue and expenditure before FRA was passed into law. Also, 63.4% of the respondents strongly agreed or agreed that a well laid out basis for the preparation of budget had existed before FRA was enacted. Notwithstanding, 46.1% of the respondents strongly disagreed or disagreed that government financial resources were better taken care of before the enactment of FRA and 54.8% of them strongly disagreed or disagreed that surpluses on oil prices had always been adequately appropriated before the enactment of FRA.

The table therefore shows that even though there had been a well laid out practice for budget preparation and information dissemination, yet government funds were not adequately taken care of and excesses on oil

prices, a major source of revenue to the government, has not been correctly appropriated before FRA came into law.

Table 8.3d
Accountability and Transparency in Fiscal Operations
Frequency distribution of Accountability and Transparency in fiscal operations

Item	Strongly Agree	Agree	Strongly Disagree	Disagree	Indifference
Q. 14 FRA has indeed brought about increased transparency in fiscal operations.	15(14.6%)	64(62.1%)	8(7.8%)	14(13.6%)	2(1.9%)
Q.15 The MTEF has effectively put in place accountability in government's fiscal operations.	8(7.7%)	66(63.5%)	10(9.6%)	16(15.4%)	4(3.8%)
Q.16 Deadline set to file in report has enhanced accountability and transparency.	8(7.7%)	56(53.8%)	10(9.6%)	22(21.2%)	8(7.7%)

Source: Field Survey, 2012

Accountability and Transparency in Fiscal Operations

The result in table 8.3d shows that about 77% of the respondents strongly agreed or agreed that FRA has indeed brought about transparency and accountability in fiscal operations. 71.2% of the participants strongly agreed or agreed that the MTEF has effectively put in place accountability in government's fiscal operations and 61.5% of the respondents also strongly agreed or agreed that the deadline set to file in report has enhanced accountability and transparency government's fiscal operations.

It can be deduced from the table that FRA has to a large extent brought about transparency and accountability in government fiscal operations and

also, the deadline set to file in report has enhanced transparency and accountability.

8.4 Test of Hypotheses

Hypothesis 1

Ho: Fiscal Responsibility Act has no implication for the budgetary role performed by the accounting profession.

Table 8.4a
Correlation Analysis between Fiscal Responsibility Act (FRA)
and Accountants' budgetary practices

		FRA	Accountants' budgetary practices
FRA	Pearson	1	.397**
	Correlation		
	Sig. (2-tailed)		.000
	N	96	95
Accountants' budgetary practices	Pearson		1
	Correlation	.397**	
	Sig. (2-tailed)	.000	
	N	95	102

** . Correlation is significant at the 0.05 level (2-tailed).

Hypothesis 1 Test result

The test of the hypotheses shown in Table 7.4a shows the relationship between FRA and Accountants' budgetary practices. The result reveals a significant positive relationship ($r = 0.397$, $p = 0.000$) between Fiscal Responsibility Act and Accountants' Budgetary practices. Since the p-value (0.000) of their relationship is less than the threshold p-value (0.05), this means that the relationship is significant. Therefore, the null hypothesis (H_0) will be rejected while the alternative hypothesis is accepted. Also, the correlation coefficient (r) of 0.397 signifies a positive relationship between the variables. This indicates that the Fiscal

Responsibility Act has implication for the budgetary role performed by the accounting profession. However, it should be noted that despite a positive relationship between the variables, the relationship is rather a weak one.

Hypothesis 2

Ho: Accountants have no role in ensuring Accountability and Transparency in Fiscal operations.

Table 8.4b
Correlation Analysis between Accountants Fiscal Responsibility Act (FRA) and Accountability and Transparency in Fiscal operations.

		FRA	Accountability and Transparency
FRA	Pearson	1	.477**
	Correlation		
	Sig. (2-tailed)		.000
	N	96	96
Accountability and Transparency	Pearson		1
	Correlation	.477**	
	Sig. (2-tailed)	.000	
	N	96	103

** . Correlation is significant at the 0.05 level (2-tailed).

Hypothesis 2 Test result

The test of the hypothesis shown in Table 8.4b indicates the relationship between accountability and transparency in fiscal operation and Fiscal Responsibility Act. The result reveals a significant positive relationship ($r = 0.477$, $p = 0.000$) between accountability and transparency in fiscal operation and Fiscal Responsibility Act. Therefore the null hypothesis (H_0) will be rejected since the p-value (0.000) of their relationship is less than the threshold p-value (0.05). Hence, the alternative hypothesis is accepted. Also, the correlation coefficient (r) of 0.477 signifies a

positive relationship between the variables and also indicates that accountants have roles to play in ensuring accountability and transparency in fiscal operations; in relation to Fiscal Responsibility Act. Nevertheless, it should be noted that despite a positive relationship between these variables, the relationship is rather a weak one.

Based on the findings of the study, the Fiscal Responsibility Act (FRA) has implications for the budgetary roles performed by public sector accountants. Although there had been a laid out practice for budget preparation and information dissemination, yet FRA has enhanced the processes of budget preparation, implementation and monitoring.

11.0 Summary and Conclusion

This study contributes to the literature, providing empirical information on Fiscal Responsibility Act and its implications on the performance of public sector accountants. It assesses the additional responsibilities FRA imposes on public sector accountants in budget preparation, implementation and control. These include the preparation of annual cash plan by the Accountant-General of the Federation, preparation of revenue and expenditure estimates for the next three financial years by government ministries, departments and agencies, publication of the disbursement schedule from the annual cash plan for the purpose of implementing the appropriation act and the provision of quarterly reports as to the utilization of fund in carrying out specific projects. The findings suggest that although, the guidelines for budget preparation had existed and information as to public revenues and expenditures had been relatively well disseminated, FRA has enhanced the performance of these functions. The results also show that FRA has brought about transparency and accountability in government fiscal operations.

10.0 Recommendations

The following are recommended based on the findings of the study:

1. Funds should continue to be monitored to ensure that that they are used for the purpose for which they are disbursed.
2. The Fiscal Responsibility Act (FRA) should be looked into and necessary adjustments which would enhance its implementation and monitoring should be made in this connection:

- a. Other tiers of government should be made to enact and enforce the Fiscal Responsibility Act.
- b. Time limits for the execution of specific tasks should be incorporated into FRA.
- c. Penalties for non-adherence to the Fiscal Responsibility Act should be spelt out.

References

Books

Due Process Handbook. (2007). *Fiscal Responsibility Act 2007*, 1-31.

Omolehinwa, E., & Naiyeju, J. K. (2011). *Government Accounting in Nigeria*. Lagos: Pumark Publishers. 1st ed.

Journals & Articles

Achua, J. K. (2009). Performance Measurement of Fiscal Responsibility Legislations in African Economies: The Nigerian Experience. *Association of Accountancy Bodies in West Africa (ABWA) Journal*.

Appah, E., & Appiah, K.Z.A. (2010). Fraud and Development of Sound Financial Institutions in Nigeria. *Nigerian Journal for Development Research*, 1(1), 49-56.

Budget Office of the Federation (2010). *2010-2012 Medium Term Expenditure Framework*.

Fiscal Responsibility Act. (2007). Act No. 31, 1-22.

Leading Edge Academy, (2010). *Institutionalising Medium Term Expenditure Framework (MTEF) in the Fiscal Governance of Nigeria: Steps to Implementing the New Nation MTEF 2010 -2013*. Treasury Management Series.

Okwoli, A.A. (2004). Towards Probity, Accountability and Transparency in Revenue Generation in the Nigerian Public Sector. *Nigerian Journal of Accounting Research*, 1(1), 1-9.

Onuorah, A.C. (2012). Accountability and Public Sector Financial Management in Nigeria. *Arabian Journal of Business and Management Review*, 1(6), 1-2.

Yelwa, A. J. (2010). Debt Management in Nigeria: Fiscal Responsibility and Public Debt. *The Process and Procedure for Obtaining Foreign Loans by Federal and State Governments*. Abuja: House of Representatives, Ad-Hoc Committee on Investigation into Foreign Loans Obtained by both the Federal and State Governments.

Yelwa, A. J. (2012). Being excerpts from a Paper presented at A One Day Town Hall Meeting: *2012 Budget and the Economy*, Organised by Actionaid on 12th March, 2012 in Abuja by the Chairman, Fiscal Responsibility Commission, Abuja. Newsdiary online.com.

2012-2015 Medium Term Expenditure Framework & Fiscal Strategy Paper. (2012). 1-15.

Websites

www.hm-treasury.gov.uk.

www.internationalbudget.org/what-we-do/open budget survey. www.imf.org/external/np/fad/trans/code.html.

IMPACT OF EDUCATION SECTOR FINANCING ON THE WELFARE OF NIGERIANS

By

Ogbole Friday Ogbole PhD

(Senior Lecturer, Dept of Accounting, Federal University, Wukari)

(drfridayogbole@gmail.com)(08068439956)

and

Samson Adeniyi Aladejare

(Lecturer, Dept.of Economics,Federal University,Wukari)

(aladejare4reel2000@gmail.com)(07031624831)

IMPACT OF EDUCATION SECTOR FINANCING ON THE WELFARE OF NIGERIANS

*The funding of education sector in both developed and developing economies across the globe is to ensure the welfare of the citizens. In most developed countries, the education sector feeds the industries with trained personnel while the goods and services produced by the industries lead to the growth and development of their economies which consequently improve the welfare of their citizens .The **objective of this study** is to investigate empirically whether the funding of the Nigerian education sector over the years has any significant **impact** on the **welfare** of Nigerians. The **research methodology adopted** is econometric times series analysis using data obtained from World Bank and Central Bank of Nigeria statistical bulletin of relevant years covering a period of 36 years (1977 - 2012) and using appropriate **explanatory and criterion variables** as proxies. **Major findings** include: strong positive correlation between expenditure on education sector and welfare of Nigerians which is not significantly affected by inflation rate; unidirectional granger causality running from recurrent expenditure to GDP per capita; significant impact of expenditure on*

education sector on welfare of Nigerians with recurrent expenditure having the significant impact, not capital expenditure; amongst others. **Policy implications** include: the need for government policies towards: Increasing expenditure in the education sector (especially capital expenditure); monitoring and supervision of such expenditure to ensure higher levels of accountability and high quality service delivery; periodic review and update of accounting and finance procedure, records and reporting in this sector in conformity with IFRS standards with the view to enhancing the welfare of Nigerians.

(**Key Words:** Education; Financing; Econometric Analysis; Granger Causality)

1.0 Introduction

The expected positive impact of Education on the welfare of the people and on the economy of any country cannot be overemphasised. The developed economies of the world attained such developmental heights due to their level of education (among other factors). Thus, *ceteris paribus*, the level of education has a strong positive relationship with the welfare of the citizens of any nation. A Person is simply a product of what he knows and can do. Expectedly, the expenditure on the education sector should have statistically significant relationship with the welfare status of the people. It is against this *a priori* expectation that this study investigates the impact of Education Sector financing on the welfare of Nigerians between 1977 and 2012, a 36 year time frame.

This study is divided into five sections: Section two deals with the review of related literature; the methodology is captured in section three; Section four deals with data analysis and discussion of results, while the fifth section deals with the conclusion and recommendations for policy decisions.

1.1 The Conceptual Framework

The objective of the study can be conceptualised in a conceptual framework in figure 1 as follows:

Impact of Education Financing on Welfare of Nigerians

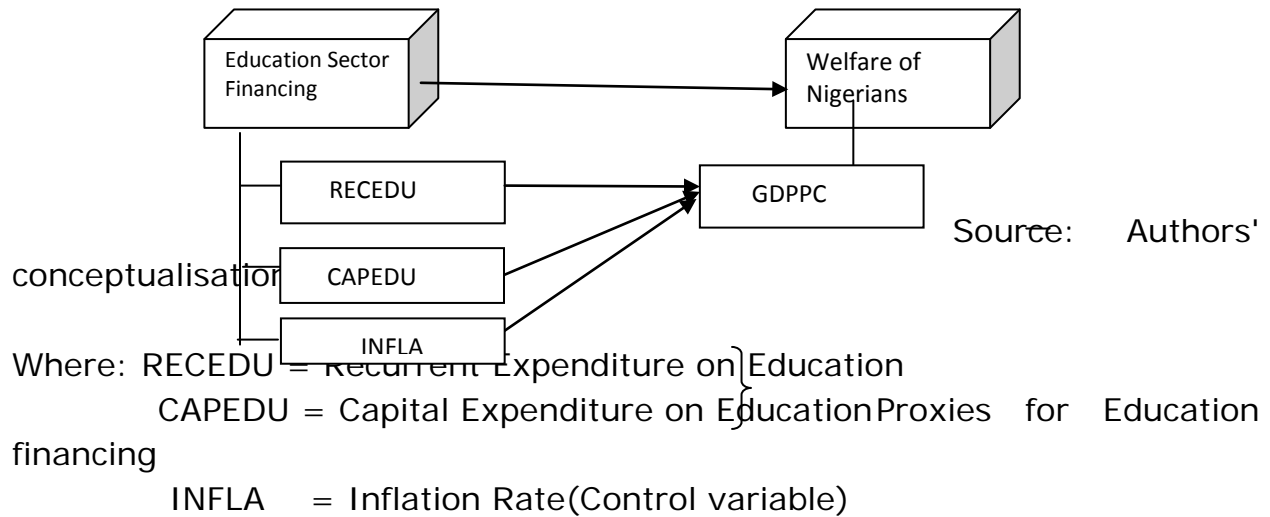

GDPPC = GDP per Capita (proxy for welfare of Nigerians)

NOTE: The above are measures/indices/proxies of the main study variables

1.2 The Objective of the Study

The main objective of the study is to investigate if education financing from 1977-2012 has any impact on the welfare of Nigerians in line with our *a priori* expectation. More specifically, the objective is broken into the following seven components:

- (i) To determine the extent of significant correlation between RECEDU and GDPPC
- (ii) To ascertain the extent of significant correlation between CAPEDU and GDPPC
- (iii) To determine the extent of significant correlation between INFLA and GDPPC
- (iv) To investigate the extent of long-run relationship between GDPPC, RECEDU, CAPEDU and INFLA
- (v) To determine the extent of significant impact of RECEDU on GDPPC.
- (vi) To ascertain the extent of significant impact of CAPEDU on GDPPC.
- (vii) To investigate the extent of significant impact of INFLA on GDPPC.

1.3 Research Hypotheses

In line with the objectives the study tests the following null hypotheses:

H₀₁: There is no significant correlation between RECEDU and GDPPC

H₀₂: There is no significant correlation between CAPEDU and GDPPC

H₀₃: There is no significant correlation between INFLA and GDPPC

H₀₄: There is no long-run relationship between GDPPC, RECEDU, CAPEDU and INFLA

H₀₅: There is no significant impact of RECEDU on GDPPC.

H₀₆: There is no significant impact of CAPEDU on GDPPC.

H₀₇: There is no significant impact of INFLA on GDPPC.

2.0. Theoretic/Emperical Review

Several researchers have studied the relationship between public sector expenditure and other variables in the economy. Walle (1998) assessed the welfare impacts of public spending and found that public spending is a potentially powerful instrument for fighting poverty. Al-samarrai (2003) in his study revealed that the link between resources spent on primary education and education outcome is weak in some sub-Sahara African countries due to certain inherent constraints. Furthermore, Anyanwu and Erhijakpor (2007) established in their study that government expenditure on education has a positive and significant direct impact on primary and secondary education enrolment rates. In their own study, Amakon and Ogujillba (2010) opined that investment in education and health care when properly targeted is an escape route from poverty. Johnson (2011) finds out in his study that there is a strong positive relationship between human capital development and economic growth.

Ordior (2011) in his study established that re-allocation of government expenditure to the education sector is significant in explaining why government expenditure on education should receive the highest priority in public investment portfolio so as to achieve a steady economic growth. It should be noted that according to UNESCO (2011) the demand for education will continue to grow regardless of resource availability. Disson, Didic and Yakautsava (2012) observed that government transfers to the education sector have strong positive externalities on both physical and human capital stocks. Also, Adelowokan (2012) found out that public investment and public consumption expenditure (in education and health) exert positive influence

on economic growth. In the same vein, Odior (2014) further recommended from his study that government has to invest in the education sector so as to reduce poverty. Furthermore, Edame and Eturoma (2014) found that public expenditure on education has a positive and significant impact on economic growth.

According to Ekankumo and Kemebaradikumo (2014) there is a negative relationship between economic development and human capital investment in Nigeria (1970-2011) but they recommend a refocus on education beyond secondary school to yield meaningful macroeconomic changes. Jalilian (n.d) opines that broad-based education is among the most powerful investments known to reduce poverty and inequality.

The above studies have revealed that *ceteris paribus* there should be a positive and significant relationship between education sector financing and the welfare of the citizen of any country. The main objective of this study therefore is to empirically investigate this *apriori* expectation in the case of Nigeria in relation to the selected time frame 1977-2012.

3.0 Methodology

The study uses econometric analysis to analyse the relationship between the criterion and explanatory variables as shown in Figure 1. Stationarity (unit root) tests (Augmented Dickey Fuller - ADF; and Phillips-Perron (PP)) were used to test the stationarity of the variables (Table 1). The Pearson product moment correlation coefficient (r) was used to test the correlation between the variables as shown in the correlation matrix (figure 5). Johansen's Co-integration test was used to test the existence of long-run relationship among the variables (Figure 6) while the causal test was conducted using Pair-wise Granger Causality test (Figure 7). Ordinary Least Square (OLS) was used for the Multiple Regression Analysis (Figure 8).

3.1 The Models:

The Correlation coefficient is calculated using the formular:

$$\frac{\sum \left(\frac{x}{\sigma_x} \cdot \frac{y}{\sigma_y} \right)}{N}$$

in which x is the deviation of one variable from its mean, y is the deviation of the other variable from its mean, and N is the total number of cases in the

series. A perfect positive correlation between the two variables results in a coefficient of +1, a perfect negative correlation in a coefficient of -1, and a total absence of correlation in a coefficient of 0. Intermediate values between +1 and 0 or -1 are interpreted by degree of correlation. Thus, .89 indicates high positive correlation, -.76 high negative correlation, and .13 low positive correlation and so on.

For the test for causality, the Granger Causality equations are:

$$Y_t = \alpha_i + \sum_{i=1}^n \alpha_i x_{t-i} + \sum_{j=1}^n \beta_j Y_{t-j} + \mu_t \quad \dots\dots(1)$$

$$X_t = b_i + \sum_{i=1}^n \lambda_i x_{t-i} + \sum_{i=1}^n \delta_i Y_{t-1} + \mu_{2t} \quad \dots\dots(2)$$

Where:

Y and X represent dependent(criterion) and independent(explanatory) variables respectively. It is assumed that the disturbances μ_{1t} and μ_{2t} are uncorrelated. **The decision rule is that if the probability value (p-value) is greater than our chosen alpha ($\alpha=0.05$), we fail to reject the null hypothesis (H_0) of "... does not Granger cause... ". If it is less than alpha, (α) then we reject H_0 .**

In the multiple regression analysis (OLS) we adopted the linear model in its generic form as:

$$y_t = a_0 + a_1 X_{1t} + a_2 X_{2t} + \dots a_n X_{nt} + U_t \quad \dots\dots\dots (3)$$

where:

- y_t = dependent(criterion) variable
- X_t = independent(explanatory) variable
- U_t = The error term

The model for the study was based on the accountants' classification of expenditure into *recurrent* and *capital* and inflation is used as a control variable because it affects the purchasing power of money. Thus, the variables are: recurrent expenditure on education (RECEDU), capital expenditure on education (CAPEDU), inflation rate (INFLA , as a control variable) all as explanatory(independent) variables while GDP per capita (GDPPC) as welfare indicator, is the criterion (dependent) variable used as

proxy for welfare of Nigerians. The specific model we have adopted is based on the above theory and is shown as:

$$GDPPC = f(RECEDU, CAPEDU, INFLA) \dots\dots\dots (4) \quad \text{This implies that:}$$

$$GDPPC_t = a_0 + a_1 RECEDU_t + a_2 CAPEDU_t + a_3 INFLA_t + \mu_t \dots\dots\dots (5)$$

4.0 Data Analysis and Discussion of Results

The stationarity tests show that the variables are stationary at first differencing (Table 1). The Correlation matrix (Figure 5) shows that GDPPC and RECEDU are strongly positively correlated (r=0.72) and also GDPPC and CAPEDU are also strongly positively correlated (r=0.70). This suggests that both pairs of variables are either decreasing or are increasing in the same direction. This agrees with the work of Disson, Didic and Yakautsara (2012). This is expected because when capital expenditure and recurrent expenditure both increase in the education sector, we expect this to translate into more positive outcomes. For example, there will be more facilities to train the students and more money to pay the staff so that there will be less industrial actions (strikes) that adversely affect the education sector. With more qualified manpower we expect better goods and services. Usually there is higher pay for more skilled workers. These all translate into improved welfare for Nigerians. However, there is weak and negative correlation between GDPPC and INFLA (-0.39). This suggests that as inflation (INFLA) increases welfare of Nigerians (GDPPC) decreases and vice versa. This is expected because prolonged inflation erodes the value of disposable income which reduces the quantity of goods and services a Nigerian can consume. This agrees with the assertion of Kennon (2015). Johansen's Co-integration tests (trace and max-Eigen) show that there is at least one co-integrating equation between the variables in the long-run. This means that the variables have long-run relationship and this is necessary because 36 years (1977-2012) is a long period and if the variables do not have long run relationship, the results may be less reliable.

Granger causality test shows that there is a unidirectional causality running from RECEDU to GDPPC ($\alpha > P$ -value 0.003). This suggests that within the period under investigation, recurrent expenditure on education (RECEDU)

has significantly influenced or impacted on the welfare of Nigerians. This is in line with the findings of Odior (2011; 2014), Adelowokan(2012) and Edeme and Eturoma (2014).But the causality did not run in the reverse direction ($\alpha < 0.75$). There is no causal relationship between CAPEDU and GDPPC ($\alpha < 0.74$ and 0.35). This may be because capital expenditure has been for some years less than recurrent expenditure. This suggests that if CAPEDU were increased, its effect/impact on the welfare of Nigerians would have been more. Alternatively, it may suggest on the other hand, that, much of what the government spent as CAPEDU was misappropriated and not spent as originally intended and hence its inability to significantly impact on Nigerian's welfare. This has a bearing with the study of Al-samarrai (2003) in which it was found out that some factors were responsible for the weak link between what government spent on education and its outcome.

The regression model is a good one having $R^2 \approx 0.60$ (60 percent of the welfare of Nigerians is explained by the explanatory variables) and $R^{-2} \approx 0.56$. The OLS result shows that: RECEDU has a positive and significant relationship with GDPPC (coefficient = 0.28 and p value = $0.03 < 0.05$). This means that for each unit change in RECEDU, GDPPC changes by 0.28 units. This also is in line with the findings of Odior (2011; 2014), Adelowokan(2012) and Edeme and Eturoma (2014). CAPEDU is also positively (coefficient = 0.94) , but not significantly ($0.07 > 0.05$) related to GDPPC. This also has a bearing with the study of Al-samarrai (2003) mentioned earlier. Being positively related to GDPPC, it suggests that if CAPEDU is increased and not misappropriated but judiciously invested into education such as in the provision of relevant educational facilities, we should expect it to impact on GDPPC significantly. INFLA is negatively (coefficient = -587) and insignificantly related to GDPPC. This agrees with the finding of Kennon (2015).Prolonged inflation is usually inversely related with the welfare of people as it erodes the purchasing power of money and the people would only benefit less, now, from the same amount of money with which they previously purchased more goods and services. Thus from the above results we reject null hypotheses: Ho_1 ; Ho_2 ; Ho_3 ; Ho_4 ; and Ho_5 but fail to reject Ho_6 and Ho_7 .

5.0 Conclusion and Recommendations

From the analyses done in this study it may be concluded that education financing in Nigeria in the period under investigation has a significant impact on the welfare of Nigerians through the recurrent expenditure (RECEDU) only. Capital expenditure (CAPEDU) is positively related but has no significant impact on welfare of Nigerians (GDPPC). The recommendations include : (i) Increase in education financing (both RECEDU and CAPEDU) through appropriate budgetary allocation; (ii) Proper supervision, monitoring and prudent management of education funds (especially CAPEDU) to ensure quality service delivery and to minimise misappropriation of funds; (iii) adequate accounting record keeping in line with IFRS and regular auditing of same to enhance prudence, probity, transparency and accountability; (iv) Periodic visitation of educational institutions by visitation panels from regulatory agencies for physical inspection of facilities, human and other resources and prompt response by appropriate authorities to reports of such inspections; and (v) provision of state-of -the- art educational training facilities and corresponding training of personnel for their usage and partnership with more advanced educational institutions in developed economies with the view to enhancing our educational standards, improving international rating of Nigerian educational institutions, and improving the welfare status of Nigerians at large.

5.1 Final Model

The conclusion can be represented diagrammatically in a model as shown below being the authors' conceptualisation.

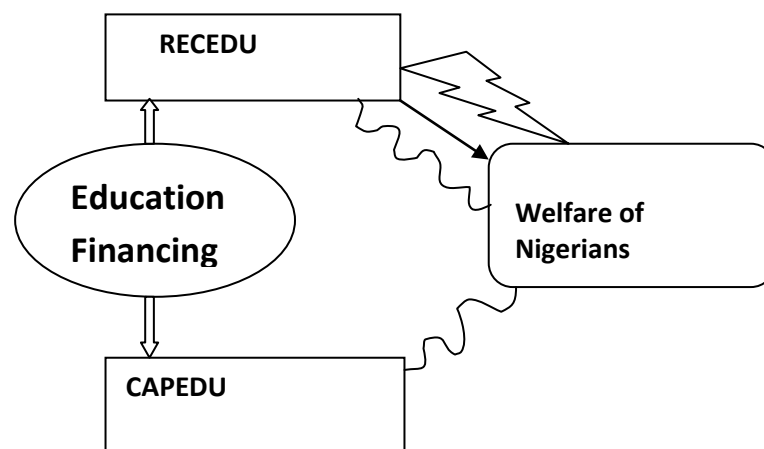

Key



Significant
impact



Causality



Strong
correlation

References

- Adelowokan, O. A (2012): Growth Effect of Evaluation and Health Expenditure in Nigeria (1970 - 2010): *African Journal of Scientific Research* 10 (1)
- Al - Samarrai, S. (2003): Financing Primary Education for all: public expenditure and education outcomes in Africa. *Institute of Development Studies*. University of Sussex, Brighton. BN/9RE.UK.
- Amakom, U. and Ogujibila, K (2010): Distributional Impact of Public Expenditure on Education and Healthcare in Nigeria: A Gender Based Welfare Dominance Analysis. *International Journal of Business and Management* 5 (12) December.
- Anyanwu, J. C and Erhijakpor, A. E. O (2007). Education Expenditure and School Enrolment in Africa: Illustration from Nigeria and other SANE Countries. *Economic Research Working Paper (No. 92)* December. African Development Bank.

- Disson, Y.; Didic, S. and Yakautsara, Y (2012): Government Spending on Education, Human Capital Accumulation, and Growth. *Department of Economics, University of Ottawa, Ontario, Canada, ydissou@ottawa.ca*
- Edame, G. E and Eturoma, A. D (2014): The Determinants of Public Expenditures on Education and Infrastructural Facilities and Economic Growth in Nigeria. *E3 Journal of Business Management and Economics* 5 (6) 152 - 161.
- Ekankumo, B. and Kemebaradikumo, N. (2014): Quality financing of Higher Education in Nigeria: A nostrum for the provision of Quality Education. *Journal of Education and Practice* (19).
- Jalilian, P. (n.d): The Effect of Female Education on Human Development and Economic Growth: A Study of Human Capital Formation in developing countries. Sodertorns hogskola: Sodertom University.
- Johnson, O. A. (2011): Human Capital Development and Economic Growth in Nigeria. *European Journal of Business and Mangement* 3 (9).
- Kennon, J. (2015): What are the effects of Inflation? Investing for Beginners. <http://beginnersinvest.about.com/od/in>
- Odior, E. S. O. (2011): Government Spending on Education, Economic Growth and long waves in a GCE micro-simulation Analysis: the case of Nigeria. *British Journal of Economics, Finance and Management Sciences* I (2)
- Odior, E. S. O. (2014): Government Expenditure on Education and Poverty Reduction: Implications for achieving the MDGs in Nigeria: A computable General Equilibrium micro-simulation Analysis. *Asian Economic and Financial Review* 4 (2): 150 - 172.
- Shobande, O. A; Odeleje, A. T. and OLunkwa, N (2014): Human Capital Investment and Economic Development: The Nigerian Experience. *World Journal of Social Science* I (2).
- UNESCO (2011): Financing Education in Sub-Saharan Africa: Meeting the Challenges of Expansion, Equity and Quality. *UNESCO Institute for Statistics International Institute for Educational Planning*.
- Walle, D. V. D (1998): Assessing the Welfare Impacts of Public Spending. *World Bank Development* 26 (3) 365 - 379 Britain.

APPENDICES

(I)

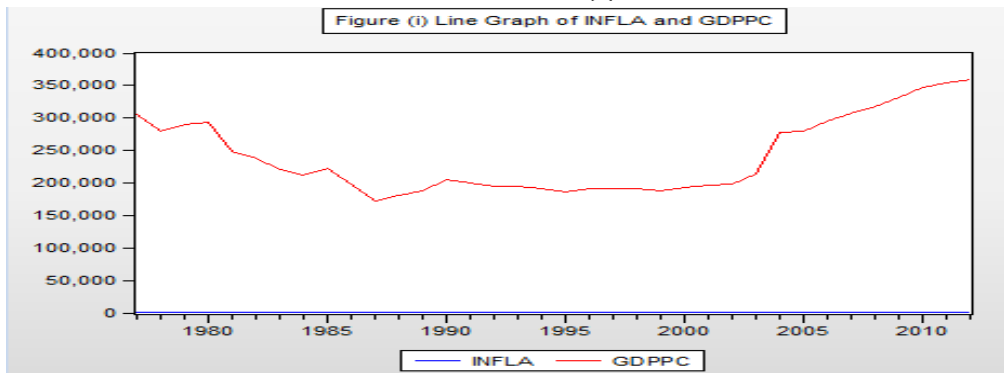

From figure (i) there is no or weak correlation between INFLA and GDPPC

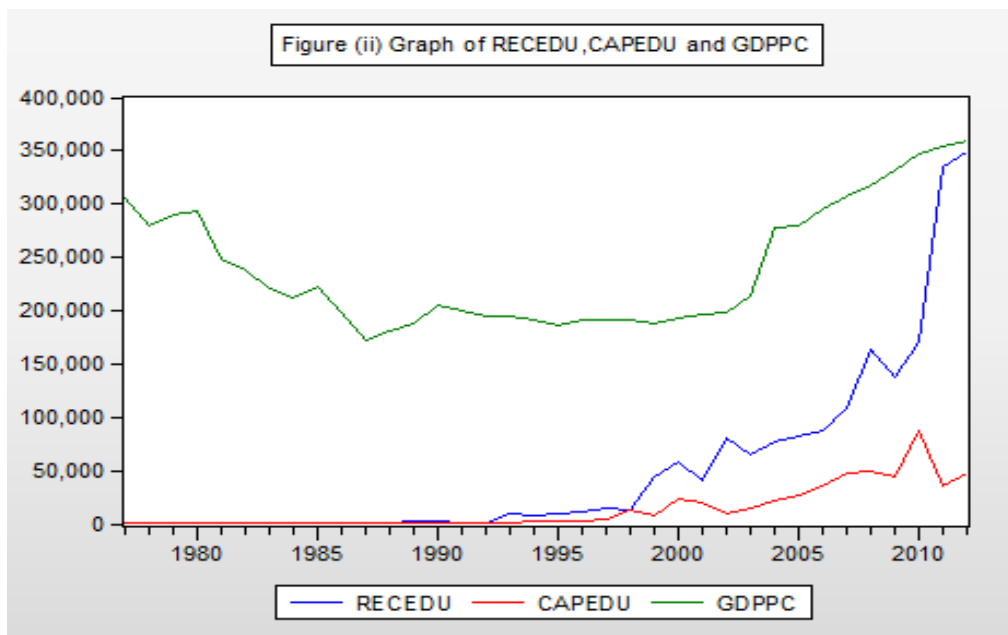

Figure (ii) shows that there is correlation between RECEDU, CAPEDU and GDPPC

APPENDIX (II)

Figure 1

PP 1ST DIFF TEST ON RECEDU WITH INTERCEPT AND TREND

Null Hypothesis: $D(\text{RECEDU})$ has a unit root

Exogenous: Constant, Linear Trend

Bandwidth: 2 (Newey-West automatic) using Bartlett kernel

	Adj. t- Stat	Prob.*
Phillips-Perron test statistic	6.504583	0.0000
Test critical values:		
1% level	4.252879	
5% level	3.548490	
10% level	3.207094	

*MacKinnon (1996) one-sided p-values.

Residual variance (no correction)	7.90E+08
HAC corrected variance (Bartlett kernel)	6.54E+08

Phillips-Perron Test Equation

Dependent Variable: D(RECEDU,2)

Method: Least Squares

Date: 05/09/15 Time: 19:07

Sample (adjusted): 1979 2012

Included observations: 34 after adjustments

Variable	Coefficient	Std. Error	t-Statistic	Prob.
D(RECEDU(-1))	1.14536	0.178498	6.416710	0.0000
C	15794.9	11094.64	1.423660	0.1645
@TREND(1977)	1484.97	566.8542	2.619684	0.0135

Phillips-Perron Test Equation
 Dependent Variable: D(CAPEDU,2)
 Method: Least Squares
 Date: 05/09/15 Time: 19:12
 Sample (adjusted): 1979 2012
 Included observations: 34 after adjustments

Variable	Coefficient	Standard Error	t-Statistic	Prob.
D(CAPEDU(-1))	1.58385	0.147684	-10.72462	0.0000
C	461.500	4012.034	-0.115029	0.9092
@TREND(1977)	132.537	191.7479	0.691207	0.4946
R-squared	0.78779	5	Mean dependent var	364.6647
Adjusted R-squared	0.77410	4	S.D. dependent var	23060.27
S.E. of regression	10960.2	0	Akaike info criterion	21.52603
Sum squared resid	3.72E+0	9	Schwarz criterion	21.66071
Log likelihood	362.942	4	Hannan-Quinn criter.	21.57196
F-statistic	57.5424	9	Durbin-Watson stat	2.158169
Prob(F-statistic)	0.00000	0		

Figure 3

PP 1ST DIFF TEST ON INFLA WITH INTERCEPT AND TREND

Null Hypothesis: D(INFLA) has a unit root

Exogenous: Constant, Linear Trend

Bandwidth: 33 (Newey-West automatic) using Bartlett kernel

	Adj. t- Stat	Prob.*
Phillips-Perron test statistic	10.71303	0.0000
Test critical values:		
1% level	4.252879	
5% level	3.548490	
10% level	3.207094	

*MacKinnon (1996) one-sided p-values.

Residual variance (no correction)	254.6201
HAC corrected variance (Bartlett kernel)	16.47165

Phillips-Perron Test Equation

Dependent Variable: D(INFLA,2)

Method: Least Squares

Date: 05/09/15 Time: 19:15

Sample (adjusted): 1979 2012

Included observations: 34 after adjustments

Variable	Coefficien	tStd. Error	t-Statistic	Prob.
D(INFLA(-1))	0.976383	0.179267	5.446531	0.0000
C	0.334732	6.121791	0.054679	0.9567
@TREND(1977)	0.033025	0.292462	0.112921	0.9108
R-squared	0.489182	Mean dependent		-0.154271

Adjusted R-squared	0.456226	var S.D. dependent	22.66
S.E. of regression	16.71110	Akaike info criterion	8.554120
Sum squared resid	8657.084	Schwarz criterion	8.688799
Log likelihood	142.4200	- Hannan-Quinn criter.	8.600050
F-statistic	14.84351	Durbin-Watson stat	1.952181
Prob(F-statistic)	0.000030		

Figure 4

PP 1ST DIFF TEST ON GDPPC WITH INTERCEPT AND TREND

Null Hypothesis: D(GDPPC) has a unit root

Exogenous: Constant, Linear Trend

Bandwidth: 5 (Newey-West automatic) using Bartlett kernel

	Adj. t-Stat	Prob.*
Phillips-Perron test statistic	6.082725	0.0001
Test critical values: 1% level	4.252879	
5% level	3.548490	
10% level	3.207094	

*MacKinnon (1996) one-sided p-values.

Residual variance (no correction)	2.20E+08
HAC corrected variance (Bartlett kernel)	1.46E+08

Phillips-Perron Test Equation

Dependent Variable: D(GDPPC,2)

Method: Least Squares

Date: 05/09/15 Time: 19:18

Sample (adjusted): 1979 2012

Included observations: 34 after adjustments

Variable	Coefficient	Std. Error	t-Statistic	Prob.
D(GDPPC(-1))	-1.064380	0.179333	5.935204	0.0000
C	-14738.11	6446.132	2.286349	0.0292
@TREND(1977)	928.6963	324.7434	2.859785	0.0075
R-squared	0.533529	Mean dependent var		919.8602
Adjusted R-squared	0.503435	S.D. dependent var		22028.87
S.E. of regression	15523.17	Akaike info criterion		22.22215
Sum squared resid	7.47E+09	Schwarz criterion		22.35683
Log likelihood	-374.7766	Hannan-Quinn criter.		22.26808
F-statistic	17.72825	Durbin-Watson stat		1.870331
Prob(F-statistic)	0.000007			

APPENDIX (III)

Figure 5 CORRELATION MATRIX

Correlation				
	GDPPC	RECEDU	CAPEDU	INFLA
GDPPC	1.000000	0.715596	0.703768	-0.386271
RECEDU	0.715596	1.000000	0.770800	-0.264889
CAPEDU	0.703768	0.770800	1.000000	-0.300360
INFLA	-0.386271	-0.264889	-0.300360	1.000000

Figure 6

JOHANSEN COINTEGRATION RESULT

Date: 05/09/15 Time: 19:20

Sample (adjusted): 1979 2012

Included observations: 34 after adjustments

Trend assumption: Linear deterministic trend

Series: GDPPC RECEDU CAPEDU

INFLA

Lags interval (in first differences): 1 to 1

Unrestricted Cointegration Rank Test (Trace)

Hypothesized		Trace	0.05 Critical	
No. of CE(s)	Eigenvalue	Statistic	Value	Prob.**
None *	0.624368	60.92814	47.85613	0.0019
At most 1	0.361721	27.63716	29.79707	0.0870
At most 2	0.277163	12.37185	15.49471	0.1400
At most 3	0.038544	1.336404	3.841466	0.2477

Trace test indicates 1 cointegrating eqn(s) at the 0.05 level

* denotes rejection of the hypothesis at the 0.05 level

**MacKinnon-Haug-Michelis (1999) p-values

Unrestricted Cointegration Rank Test (Maximum Eigenvalue)

Hypothesized		Max-Eigen	0.05 Critical	
No. of CE(s)	Eigenvalue	Statistic	Value	Prob.**
None *	0.624368	33.29098	27.58434	0.0083
At most 1	0.361721	15.26531	21.13162	0.2707
At most 2	0.277163	11.03544	14.26460	0.1524
At most 3	0.038544	1.336404	3.841466	0.2477

Max-eigenvalue test indicates 1 cointegrating eqn(s) at the 0.05 level

* denotes rejection of the hypothesis at the 0.05 level

**MacKinnon-Haug-Michelis (1999) p-values

D(GDPPC)	-0.132606	0.835432	-1.643003
	(0.03806)	(0.20405)	(0.52810)
D(RECEDU)	0.061418	-0.121583	1.305719
	(0.05876)	(0.31501)	(0.81528)
D(CAPEDU)	-0.021367	0.145853	-0.121496
	(0.02267)	(0.12154)	(0.31455)
D(INFLA)	-4.64E-05	8.87E-05	-0.000399
	(4.0E-05)	(0.00022)	(0.00056)

Figure 7
GRANGER CAUSALITY RESULT

Pairwise Granger Causality Tests
Date: 05/09/15 Time: 19:21
Sample: 1977 2012
Lags: 2

Null Hypothesis:	Obs	F-Statistic	Prob.
RECEDU does not Granger Cause GDPPC	34	7.3180	0.0027
GDPPC does not Granger Cause RECEDU		0.2892	0.7510
CAPEDU does not Granger Cause GDPPC	34	2.6496	0.0877
GDPPC does not Granger Cause CAPEDU		0.8005	0.4588
INFLA does not Granger Cause GDPPC	34	0.3071	0.7379
GDPPC does not Granger Cause INFLA		1.0809	0.3525
CAPEDU does not Granger Cause RECEDU	34	12.849	0.0001
RECEDU does not Granger Cause CAPEDU		14.392	5.E-05

INFLA does not Granger Cause RECEDU	34	0.0308	8	0.9696
RECEDU does not Granger Cause INFLA		0.6479	0	0.5306
INFLA does not Granger Cause CAPEDU	34	0.2811	3	0.7570
CAPEDU does not Granger Cause INFLA		0.7597	9	0.4768

Figure 8
OLS REGRESSION RESULT

Dependent Variable: GDPPC
Method: Least Squares
Date: 05/09/15 Time: 19:37
Sample: 1977 2012
Included observations: 36

Variable	Coefficient	Std. Error	t-Statistic	Prob.
C	224605.9	12153.14	18.48130	0.0000
RECEDU	0.276644	0.118368	2.337143	0.0259
CAPEDU	0.940741	0.503485	1.868460	0.0709
INFLA	-587.0652	390.2733	-1.504241	0.1423
R-squared	0.597597	Mean dependent var		240406.8
Adjusted R-squared	0.559871	S.D. dependent var		58063.69
S.E. of regression	38520.72	Akaike info criterion		24.06022
Sum squared resid	4.75E+10	Schwarz criterion		24.23617
Log likelihood	-429.0839	Hannan-Quinn criter.		24.12163
F-statistic	15.84074	Durbin-Watson stat		0.247582
Prob(F-statistic)	0.000002			

Figure 9 NORMALITY TEST

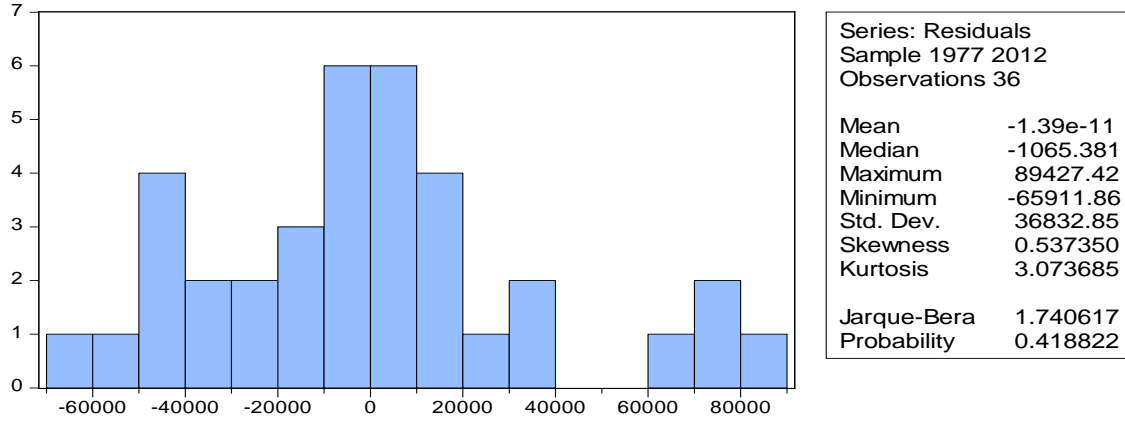

Figure 10
TEST FOR HETEROSKEDASTICITY
Heteroskedasticity Test: Breusch-Pagan-Godfrey

	2.60256		
F-statistic	4	Prob. F(3,32)	0.0690
	7.06086	Prob. Chi-	
Obs*R-squared	9	Square(3)	0.0700
Scaled	5.78450	Prob. Chi-	
explained SS	2	Square(3)	0.1226

Test Equation:
Dependent Variable: RESID^2
Method: Least Squares
Date: 05/10/15 Time: 07:09
Sample: 1977 2012
Included observations: 36

Variable	Coefficient	Standard Error	t-Statistic	Prob.
C	2.65E+0	5.70E+0	4.652771	0.0001
	-			
RECEDU	3900.38		-	
	7	5550.296	0.702735	0.4873
CAPEDU	-	23608.44	-	0.4119

	19629.5	0.831462	
	2		
	-		
	4253579	1829994	-
INFLA	7	9 2.324367	0.0266
<hr/>			
R-squared	0.19613	Mean dependent	
	5var		1.32E+09
Adjusted R-squared	0.12077	S.D. dependent	
	3var		1.93E+09
S.E. of regression	1.81E+0	Akaike info	
	9criterion		45.57134
Sum squared resid	1.04E+2	Schwarz	
	0criterion		45.74729
	-		
Log likelihood	816.284	Hannan-Quinn	
	2criter.		45.63275
F-statistic	2.60256	Durbin-Watson	
	4stat		0.455832
Prob(F-statistic)	0.06901		
	8		
<hr/>			

Figure 11 RESIDUAL STABILITY TEST

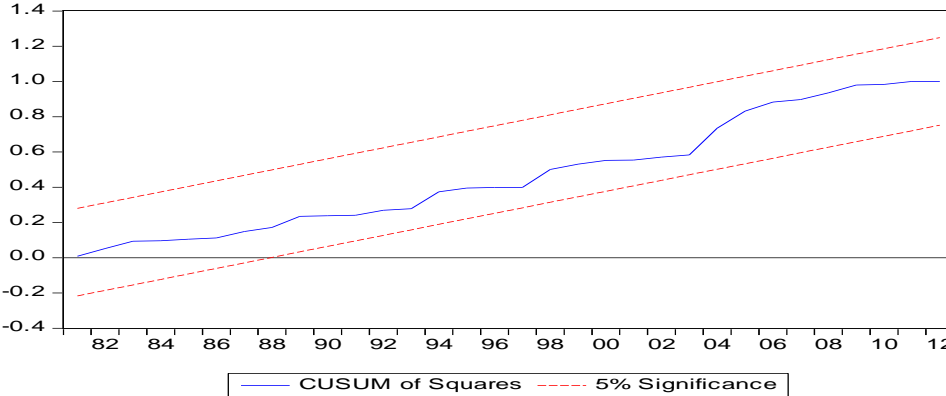
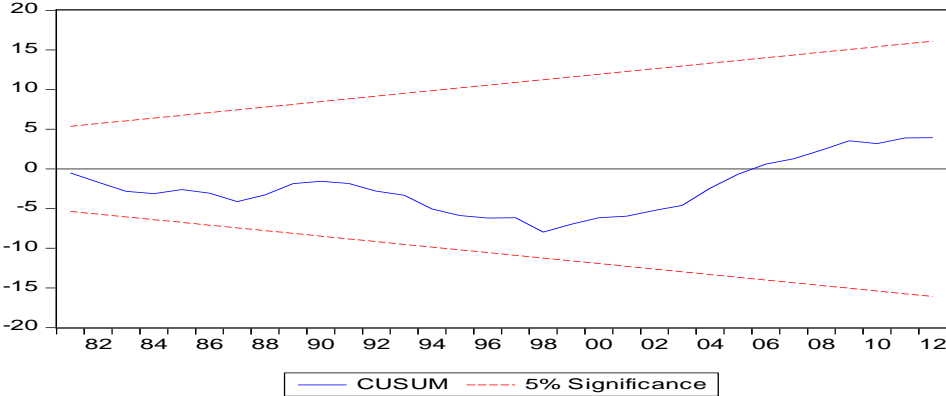

YEAR	RECEDU	CAPEDU	INFLA	GDPPC
-------------	---------------	---------------	--------------	--------------

APPENDIX V
Table 1 (Research Data)

year	Recedu	capedu	infla	gdppc
1977	173.72	500	15.08783	305694.2
1978	167.29	301.4	21.70925	279425.3
1979	151.23	533.2	11.70973	289536.8
1980	155.81	952.6	9.972262	293200.6
1981	165.43	440.9	20.81282	247876.9
1982	187.93	488.4	7.697747	238954.8
1983	162.15	346.6	23.21233	221196.5
1984	198.9	144.9	17.82053	211302.8
1985	258.6	180.7	7.435345	223088.3
1986	262.71	442	5.717151	198319.6
1987	225.01	139.1	11.29032	172402.7
1988	1458.8	281.8	54.51122	180584.5
1989	3011.8	221.9	50.46669	187298.5
1990	2402.8	331.7	7.3644	205824.6
1991	1256.3	289.1	13.00697	199406
1992	291.3	384.1	44.58884	195279.9
1993	8882.38	1563	57.16525	194428.4
1994	7382.74	2405.7	57.03171	191358.7
1995	9746.4	3307.4	72.8355	186069
1996	11496.15	3215.8	29.26829	190543.1
1997	14853.54	3808	8.529874	191047.7
1998	13589.49	12793	9.996378	191386.7
1999	43610.65	8516.6	6.618373	187537.2
2000	57956.64	23342.6	6.933292	192616.4
2001	39882.6	19860	18.87365	196119.9
2002	80530.88	9215	12.87658	198471
2003	64782.15	14680.2	14.03178	213526.2
2004	76524.65	21550	14.99803	278318.7
2005	82795.06	27440.8	17.86349	280508.1
2006	87294.56	35,791.80	8.239527	295642.5
2007	107529.39	48,293.51	5.382224	307520.8
2008	164000	48,800.30	11.57798	318113.2
2009	137,116.00	43,405.00	11.53767	331036.8
2010	170,800.00	87,904.65	13.7202	347317.8
2011	335,800.00	35,400.00	10.84079	354341.4
2012	348,400.00	47,600.00	12.21701	359347.8
			8.475827	368301.8

TAXATION

EFFECTS OF TAX CONTROL MEASURES ON COLLECTABLE TAX REVENUE FROM COMPANIES IN BORNO AND YOBE STATES, NIGERIA

By

Baba Yagana Alhaji, ACA
Department of Accounting,
University of Maiduguri
yagana_baba@yahoo.com
07036824181

And

Ahmed Modu Kumshe, PhD, FCA
Department of Accounting,
University of Maiduguri
amkumshe@gmail.com
07033278606

ABSTRACT

Occurrence of tax evasion and tax avoidance have remained issue of concern to different tax administrators and in order to curtail the incidence and improve revenue base in the State, government has put in place set of tax control measures. On this premise, this study sought to examine the effects of tax control measures on collectable tax revenue from companies in Borno and Yobe State, Nigeria over period of 5 years (2009-2013). This study relied extensively on secondary data. The data was gathered from periodic statistical bulletin, assessment registers, self-assessment and government assessment form of Federal Inland Revenue Service (FIRS) Maiduguri and Damaturu branches. The findings showed that tax control measures are significantly related to revenue from companies. While both tax penalties and additional assessment were found to have positive effect on CIT revenue, the result revealed statistical significance of the measures in both States. On the other hand, Pre-operational levy in Borno State revealed a

negative effect on CIT revenue and statistically significance, however preoperational levy in Damaturu revealed negative effect but statistically insignificant. The joint effect of tax penalty, additional assessment and preoperational levy on collectable tax revenue from companies also revealed a positive correlation and statistical significance in both States. Most tax control measures proved effective in both States. However, despite the effectiveness of these control measures incidence of tax evasions do exist in our society. The study therefore suggests among others the strict enforcement of fiscal tax control measures as the last resort in ensuring more revenue to the government while the inspectors in charge of fiscal control should be properly trained in terms of new development, professionalism and tax moral.

Keywords: Tax Control Measures, Collectible Tax, Tax Revenue, Tax Avoidance, Tax Evasion,

1.0 Introduction

It is the responsibility of every government to provide certain goods and service to its citizen for the betterment of their lives. Nigeria, like every country of the world with a strong belief in the right to own private property, has a Government that undertakes a lot of activities to better the lives of the common man. Government extract in various proportion from the wealth of the citizen in the form of taxes for these purposes. However government agencies are not necessarily gauging up to their responsibilities in the provision of social service to the society perhaps it is due to insufficient revenue generated. In the developing countries especially in Nigeria, tax is observed in the breach continuously by its so called citizen either in form of tax evasion or deliberate avoidance. This may be attributed to poor tax control measures. Government in some developing countries find it difficult to design tax control measures and the few that have find it difficult to ensure strict implementation hence poor tax collection reported.

Despite the tax control measures put in place, there have been increasing challenges from tax evasion and avoidance over the years and these problem have remain abated in both developed and developing countries. Tax revenue collected in billions of naira by government ministries department and agencies are not remitted to government coffers (Yusuf 2012). The most worrisome part of all is the incorporative posture of these ministries, department and agencies that saw nothing wrong in their act to

the detriment of the smooth running of the government. On the other hand, little or nothing had been done by government toward recovering the money. Tax compliance in Nigeria is abysmally low and has been describe as nothing good to write home about compared to other nations. Nigerian tax system is characterized by lack of tax payer enlightenment and education, corruption in public office and lack of accountability. Government effort in ensuring transparency, accountability and good governance is not appreciated by its citizen. There is no doubt revenue to any government can be reduced by unpatriotic acts of its citizens. Review of related literature shows that studies on similar topic are still scarce especially in this part of the country.

Objectives of the study

The study assessed the effects of tax control measures with the aim of achieving the following objectives

- I. Effect of tax penalty on revenue from companies
- II. Effect of additional assessment on revenue from companies
- III. Effect of pre operational levy on revenue from companies
- IV. Joint effects of tax penalty, additional assessment and pre operational levy on revenue from companies

Research Hypotheses

The following research hypotheses were formulated and tested

H₀₁: Imposition of tax penalty has not significantly improved revenue from companies

H₀₂: Imposition of additional assessment has not significantly improved revenue from companies

H₀₃: Imposition of pre-operation levy has not significantly improved revenue from companies

H₀₄: Impositions of tax penalty, additional assessment and pre-operation levy collectively have not significantly improved revenue from companies

2.0 Literature Review

Tax revenues are crucial to all forms of government. Without these revenues, most governments would be unable to offer the sound

environment that is necessary for their citizens and businesses to prosper. For this reason, in most countries, failure to pay taxes can result in severe penalties. These penalties typically include fines and in some cases can even result in incarceration. Tax revenue is the [income](#) that is gained by [governments](#) through [taxation](#). Just as there are different types of tax, the form in which tax revenue is collected also differs; furthermore, the [agency](#) that collects the tax may not be part of central government, but may be an alternative third-party licensed to collect tax which they themselves will use (Paul, 2012).

Once a year, every company is required to file a return with the FIRS. Some of the returns include statement of affairs, audited financial statement, computation of income and education tax among others. Failure to comply with the law will attract penalty continuously up to the date of filling the return. Additional assessment is passed on company where it is discovered after desk examination a company has not been assessed or was under assessed. Also best of judgment and back duty investigation will be passed where the tax authority discovers that a company failed to file return within the stipulated time or assessment raised for unpaid taxes in prior periods. From time to time, tax audit is carried out in order to checkmate and ensure tax compliance on the part of the tax payers.

However, these "Twin devils" tax evasion and avoidance have created a great gulf between actual and potential revenue. The government has for the umpteenth time complained of the widespread incidence of tax avoidance and evasion in the country as companies and other taxable persons employ various tax avoidance devices to escape or minimize their taxes or deliberately employ fraudulent ways and means of evading tax altogether sometimes with the active connivance of the tax officials (Kibiel and Nwokah, 2009). Tax evasion and avoidance no doubt deny any government the tax revenue due to her, which results in a gap between the potential and actual tax collections while the law regards tax avoidance as a legitimate game; tax evasion is seen as immoral and illegal. Tax evasion has profoundly negative effect for the purpose of removal under the control a significant amount, endangering the economic and social policies but also its openness to corruption lane highest levels. This tax evasion is considered a manifestation of anti-democratic and the effect of tax evasion is in this view negative. Tax evasion, complex social and economic phenomenon facing

contemporary society, it is hard to quantify but its direct and indirect effects on economic development are felt. It is in this light that it becomes necessary the government should resort to the use of enforcement as the last option after going the whole haul to achieve voluntary compliance without result, hence the concept of tax control mechanism. The main purpose of penalty policy is to provide an opportunity for the offender to reintegrate himself or herself into society and to rectify the damage both to the victim and to society caused by the crime (Kabera, 2009). A system of tax cannot be run successfully without registering some form of hitches in its administration (Ariyo 1997). These problems among others are complex legislation deficient collection system and even administration. Hence increasing the incidence of evasion and avoidance, thus tax control mechanism.

Tax control in this context, are conscious efforts and measures taken by government in order to enhance revenue generation and to mitigate tax evasion and avoidance i.e. to avoid confrontation with phenomenon of tax evasion and avoidance and if it has occurred, in order not to let it reach a destructive dimension in the economy. Many literatures on how to improve tax revenue collection have been reviewed and have highlighted the importance tax control measures in improving revenue generation. One significant work is emphasized by Bebes (2012), on how to improve income collection: new sanctions stipulated for the taxpayers who fail to pay their taxes on time. Another significant work is given by Cucosel (2012) on the activity of fiscal control measures in which a significant amount was attracted to the State budget from penalty on late payment, additionally calculated difference and other fines. Loan, 2012 discussed on Tax Control: Prevention and Control of Tax Evasion, aiming at checking how to determine the taxable base, the amount of tax payable and determining the delay increases, penalties, or propose penalties for violations of tax laws in any form. Methodological approach will be discussed in the next section

3.0 Methodology

The study was carried out in Borno and Yobe State. It is a secondary based research, periodic statistical bulletin, self and government assessments, registers and duplicate copies of forms were specifically used to collect data. A research is of no meaning until data collected are analyzed and

hypotheses tested. Data collected were analyzed using both descriptive and inferential statistic. Descriptive statistics such as tables, frequencies and simple percentage were used while inferential statistics such as correlation and regression analyses were used to test the hypotheses. Simple regression model thus;

$$Y = \beta_0 + \beta_1 x_1$$

Multiple regression model thus

$$Y = \beta_0 + \beta_1 x_1 + \beta_2 x_2 + \beta_3 x_3 + \varepsilon$$

Where

Y is the dependent variable (amount realized from companies' income tax)

X are independent variables (amounts realized from tax penalty, additional assessment and preoperational levy)

β_0 is the constant

β_1 - β_3 are coefficient of regression and

ε is stochastic term of the regression

4.0 Data Presentation and Analysis

Data gathered are presented in tabular form for easy understanding and analysis. Each table shows the comparative analysis of companies' income tax and various tax control measures. While correlation and regression analysis were used to test the hypotheses formulated. These tools were adopted because it portrays clearly aim of the study. The data presented in tables 4.1 and 4.2 are in respect of Maiduguri branch and for Damaturu branch respectively.

Table 4.1: Comparative Figures of Companies Income Tax (CIT) and Tax Penalty, additional assessment and pre-operational levy for periods 2009-2013 Borno State

Year	CIT ₦	Tax penalty ₦	Additional assessment ₦	Pre-operational levy ₦	Combined tax penalty, additional assessment and preoperational levy ₦
2009	49,689,636	7,950,342	3,428,585	3,015,435	14,394,362

2010	30,918,586	4,328,682	2,504,405	5,560,530	12,393,537
2011	34,792,604	5,218,891	3,131,334	4,251,630	12,601,855
2012	25,315,727	3,087,887	1,697,838	5,203,620	9,989,345
2013	24,162,886	3,382,804	1,884,705	5,462,640	10,730,149
Total	164,879,439	23,968,606	12,646,867	23,493,855	60,109,248

Source: FIRS Remittance Summary, 2014

Table 4.1 shows figures of companies income tax (CIT) revenue collected and their respective tax penalties, additional assessment, pre-operational levy and their combined figures for the period of five years 2009 to 2013 for Maiduguri. The greatest part of the revenue from companies was in the year 2009 with N49, 689,636 while the least tax revenue generated in the period was in 2013 with N24, 162,886. The highest tax penalty charged was in the same year with N7, 950,342 accounting 16% of the revenue generated that year while the least tax penalty charge was N3, 087,887 in 2012 representing 12% of revenue that year.

The highest additional assessment charged on companies' in the period under review was in 2009 accounting for 7% of the income tax of that year. This was possibly due to the integrated FIRS performance reported up to 2009, while the least reported additional assessment was in 2012 also accounting for 7% contribution. However there were fluctuations in additional assessment charge observed during the period under review.

Pre-operational levy and companies' income taxes ideally have inverse relationship that is, an increase in companies' income tax means decrease in pre-operational levy and vice versa. Decline in Pre-operational levy is actually good for companies' income tax in the state while increase in preoperational levy is not healthy to the state. Pre-operational levy when taken as a percentage of the companies income tax generated in these years accounted for 6%, 18%, 12%, 21% and 23%. This constant increase is not healthy for the state because, it has resulted in reduced companies' income tax revenue generated. However, there was a decrease witnessed also in 2011, a 12% fall from 2010 report.

For the comparative figure of tax control measures and its combined effect on CIT revenue in Borno state, the highest tax penalty and additional assessment were both reported in 2009 accounting for 16% and 7%

respectively whereas the highest pre-operational levy was recorded in 2010. Again the least tax penalty and additional assessment were reported in the same year in 2010 while the least pre-operational levy was reported in 2009 accounting for 6% of the revenue collected that year. However, looking at the effects of each control measure in totality, tax penalty has the highest effect on CIT in the 5 years under study amounting to N23, 968,606. This is followed by pre-operational levy amounting to N23, 493,855 and the least contribution is from additional assessment amounting to N12, 646, 867

Similarly, when the tax control measures were put together, the highest was also reported in 2009 while the least was reported in 2012. From the table again, it was observed that substantial part of the CIT revenue collected in these years came from tax control measures accounting for 36% of the overall CIT generated in 5 years. This has indeed reflected strong contribution of tax control measures on CIT revenue in the state.

Table 4.2 revealed the summary of company income tax collected and the respective tax penalties, additional assessment, pre-operational levy and their combined figures for the period of five years 2009 to 2013 for Damaturu

Table 4.2: Comparative Figures of Companies Income Tax (CIT) and Tax Penalty, additional assessment and pre-operational levy combined for the period of five years (2009-2013) Yobe State

Years	CIT ₦	Tax penalty ₦	Additional assessment ₦	Pre-operational levy ₦	Combined tax penalty, additional assessment and preoperational levy ₦
2009	5,375,740	376,302	183,817	1,292,290	1,852,409
2010	4,224,030	337,923	367,491	1,217,090	1,922,503
2011	4,318,512	215,926	427,533	772,480	1,415,939
2012	3,929,233	235,754	365,509	956,920	15,58,183
2013	9,858,855	690,120	828,144	837,340	23,55,604
Total	27,706,370	1,856,025	2,172,494	5,076,120	9,104,638

Source: FIRS Remittance Summary, 2014

Damaturu office, the highest revenue generated was in 2013 amounting to N9, 858,855 while the lowest reported was in 2012. Again, the highest tax penalty charged was in the same year while the lowest tax penalty reported was in 2011 amounting to 215,926. Looking at the small nature of the state, CIT revenue collected is generally low. Despite that, the branch still witnessed decline in its revenue over these periods until 2013, where it witnessed rapid increase up to 60% compared to 2012. This decline could be a factor of disintegration of the FIRS into MSTO and GBTO as well as the security challenge in the state. While the increase in revenue to 2013 could be a faction of improved security situation, improved compliance level and willingness to pay tax on the part of the tax payers.

Similarly, tax penalty also showed a decline over the period under study. However, decline in tax penalty is on indication of improvement on the part of the tax payers i.e. more companies are willing to pay tax resulting in few default cases reported. In 2013, tax penalty severely rose to as high as N690, 120 as against N235, 754 in 2102 accounting for 66% increase. This increase was a factor of increase revenue in the same year.

The highest additional assessment reported during these periods was in 2009 amounting to N8, 281,144 representing 8% of the CIT revenue generated that year while the least reported was in 2009 amounting to N183817 representing only 3%. However during periods 2009-2013, there were fluctuations in the additional assessment charged on companies. Ideally, decrease in additional assessment is an indication that companies are charged tax and correct tax amount are paid. In other word improved compliance. For instance 2010, 2011, 2012 and 2013, there were increase in additional assessment witnessed. Although, additional assessment have been raised against companies and tax recovered but it is simply Indicating that tax defaulters are on increase and strict implementation of additional assessment is required to reduce the incidence.

The highest preoperational levy figure reported was in 2010 accounting for 29% of revenue that year while the least reported was in 2013 accounting for 9% only. Again there were fluctuations between 2011 and 2013. For instance in 2009, so many companies reported yet to commence business

while in 2011, small number reported yet to commence business. Although an amount inform of pre-operational levy had been generated from those companies, but so much CIT revenue have been lost because these companies have not started business operations. Increasing pre-operation levy is not healthy to the state CIT revenue because if so many companies fail to start operation, only little will be collected from already existing companies to provide basic services to the citizens.

The highest tax penalty and additional assessment were both reported in the same year in 2013 where as pre-operational levy highest figure was recorded in 2009. However, when all the tax control measures were put together, the highest was still recorded in 2013 while the least was recorded in 2011 accounting for as high as 33% of the revenue collected that year. Although there are variations in the contribution of these measures each year, it is obvious that these measures have contributed substantially to the CIT revenue each year in the state. For instance in 2010, N1, 922, 503 equivalent to 44% of CIT revenue in that year was from tax control measures. This implies that adequate enforcement of tax control measures will do a lot well toward improved revenue generation in the state.

In conclusion, considering the performance report of the two branches, Maiduguri generated N164, 879, 439 company incomes tax revenue while Damaturu generated N27, 706, 370 company incomes tax revenue in total despite the intensity of the insurgency in the two states. This implies that the states would have performed even better assuming these challenges do not exist. On the other hand, tax payer are naturally non-compliant, taxpayers' enlightenment, campaign and awareness is necessary on the part of government. And that government should adopt enforcement as the last resort after complete over haul of voluntary compliance process.

Test of Hypotheses

In order to establish the relationship and effect between the dependent and independent variable correlation and regression analyses were used. The outcomes of the tests are presented in tables 4.3 and 4.4 presenting Maiduguri and Damaturu branches.

Table 4.3: Correlation and regression outcome of hypotheses i-iv Maiduguri branch

CIT	Tax penalty	Additional Assessment	Pre-Operational Levy	Combined tax penalty, additional assessment and preoperational levy
R	0.995	0.909	-0.935	0.996
R ²	0.991	0.826	0.874	0.991
Adjusted R ²	0.987	0.768	0.832	0.964
α	0.05	0.05	0.05	0.05
P	0.000	0.033	0.020	
F				0.012

Source: SPSS correlation and regression outcome, 2014.

Table 4.3 is correlation and regression outcome table of Maiduguri branch. The table correlated and regressed the dependent variable companies' income tax against each independent variable (tax penalty, additional assessment and pre operational levy) differently.

Table 4.4: Correlation and regression outcome of hypotheses i-iv Damaturu branch

CIT	Tax penalty	Additional Assessment	Pre-Operational Levy	Combined tax penalty, additional assessment and preoperational levy
R	0.969	0.991	-0.303	0.987
R ²	0.939	0.982	0.092	0.975
Adjusted R ²	0.919	0.976	0.089	0.965
α	0.05	0.05	0.05	0.05
P	0.007	0.001	0.621	
F				0.005

Source: SPSS correlation and regression outcome, 2014.

Table 4.4 is a correlation and regression outcome table of Damaturu branch. The table correlated and regressed the dependent variable (companies income tax against each independent variable (tax penalty, additional assessment and pre-operational levy) differently.

Results and Discussion

The correlation and regression output in table 4.3 representing Maiduguri branch revealed that there exist a relationship between tax control measures and revenue from companies in Borno and Yobe States. This is evidenced by the correlation coefficients of 0.995, 0.99 and -0.935 respectively for tax penalty, additional assessment and pre operational levy. Table 4.3 also revealed that tax penalty, additional assessment and pre operational levy are strict functions of the dependent variable CIT. The strength of the model is attested by the coefficients of determination of 0,991, 0.826 and 0.874. This implies that about 99%, 83% and 87% of the variation in CIT has been explained by the independent variables tax penalty, additional assessment and pre operational levy. After adjusting for degree of freedom, the model could still explain 99%, 78% and 83% respectively while only 1.3%, 22% and 17% are left unaccounted for which has been captured by the stochastic disturbance term in the model. With p values of 0.00, 0.033 and 0.020 all less than α of 0.05 null hypotheses were rejected with respect to objectives i, ii, iii. This indicates that imposition of tax penalty, additional assessment and pre operational levy has significantly improved on revenue from companies in Borno State respectively. The joint effect of tax penalty, additional assessment and pre operational levy on companies' income tax revealed a positive correlation of 99.6%. Furthermore, with f value of 0.012 still less than α of 0.05, null hypothesis still rejected with respect to objective IV. This implies that imposition of tax penalty; additional assessment and pre operational levy jointly have improved on revenue from companies in Borno State.

From Table 4.4, it was observed that tax penalty additional assessment and pre operational levy are correlated with collectable tax revenue from companies in Yobe State. Specifically, tax penalty and additionally calculated difference are positively correlated with 97% and 99% while pre operational is correlated negatively with correlation coefficient of -0.303. The table further revealed that tax penalty and additional assessment are strict function of the dependent variable CIT in Yobe State. The strength of the

model was attested by coefficient of determination of 0.94 and 0.98. However, only about 9% variation in the CIT revenue is explained by pre operational levy while 91% variation in CIT is left unaccounted for in the model. This simply indicates that pre operational levy is not a strict function of the dependent variable CIT and that the model is not a good fit for the data in Damaturu branch. In addition, with p values of 0.007, 0.001 and 0.621, two less than α of 0.05 and one greater than α of 0.05 two null hypotheses with respect to objective I and ii are rejected while null hypotheses with respect to objective iii is accepted. This implies that imposition of tax penalty and additional assessment have improved revenue from companies but imposition of preoperational levy has not significantly improved on revenue from companies in Yobe State. This may have resulted consequent to the size, age and number of companies operating in Borno State. It should be noted that although pre operational levy has passed significance test in Borno State but it is not healthy to the State due its negative effect on collectable tax revenue from companies.

Furthermore, the joint correlation coefficient of 0.987 revealed a perfect positive relationship between tax penalty, additional assessment and pre operational levy on revenue from companies in Yobe State. And with f value of 0.005 less than α of 0.05, null hypothesis is rejected with respect to objective IV. Therefore tax penalty, additional assessment and preoperational levy is said to have significantly improved on revenue from companies in Yobe State. This outcome is partially in line with the work of Cucosel 2012 because of similarities in the tools used for the analysis.

In conclusion, the stability and growth is a function of the ability of the government to stimulate and sustain high level of activities and optimal mix of revenue generation instrument. One way this can be achieved is through strict implementation and enforcement of tax control measures. Therefore, it lies on the government to properly harness these tools to reverse the trend tax evasion and avoidance.

Reference

Ariyo A. (1997) Productivity of the Nigerian tax system 1970-1990, African Economic Research Consortium, the Regal Press Kenya Ltd, Nairobi

Bebes V. (2012) Efficiency of fiscal control and anti-tax evasion measures carried out by the General Directorate of Public Finance Maramures, *International Journal of Academic research in Accounting, Finance and Management Sciences*, Romania. Volume 2, Issue 1 ISSN: 2225-8329

Cucosel C. (2012) Analysis of the activity of fiscal control carried out by the general directorate of public financem Maramures: Constantin Technical University of Cluj-Napoca, *International Journal of Academic Research in Business and Social Sciences* November 2012, Vol. 2, No. 11 ISSN: 2222-6990

FIRS remittance summary (2009-2013)

Kabera K. (2009) A Critical Analysis of Effectiveness of Tax Offences Control Mechanisms under Rwandan law, Kigali Independent University Faculty of Law, Kigali.

Kiabel B. & Nwokah (2009) Curbing tax evasion and avoidance in personal income tax Administration, *European Journal of Economic, Finance and Administrative Science*, Department of Accounting, Faculty of Management Sciences, Rivers State University of Science and Technology, Port Harcourt, Rivers State, Nigeria.

Loan P. (2012) Tax Control: Prevention and Control of Tax Evasion, Faculty of Economic and Business Administration Babes-Bolyai University, Cluj-Napoca, Romania.

Paul Krugman (2012) [More Laffering](#) the New York Times, Dec 2012.international monetary fund, government finance statistical year book and data files

Yusuf I.A (2012) Critique of tax regime, the nation newspaper, March 28, 2012.

DO TAX INCENTIVES DETERMINE FOREIGN DIRECT INVESTMENT IN THE NIGERIAN OIL AND GAS SECTOR?

By

BABATUNDE, SHAKIRAT ADEPEJU, B.Sc. (Hons.), M. Sc. MBA, Ph. D.
research fellow, FCA, MIPA

Department of Accounting, School of post- graduate studies, University of
Lagos

E-mail: yasinfatiha@gmail.com, Telephone: 2348033007121 (Corresponding
author)

And

YOHANA GYANGJUGU, Ph.D., ACA, CFA

Department of Actuarial Science, University of Jos

E-mail: yjugu@yahoo.com

Telephone; 2348036576079

Abstract

The aim of this study is to empirically evaluate the extent to which tax incentives are determinants of foreign direct investments (FDI) in the oil and gas sector in Nigeria if any. Data from a population of seventeen (17) FDI oil and gas companies were analysed. The study employed frequencies, descriptive statistics and Karl Pearson coefficient of correlation, r , statistical method of analysis to analyse the data collected. The research variables are FDI as independent variable, petroleum investment allowance and tax paid as the dependent variables. Two hypotheses were formulated and tested to provide empirical evidence in support of the determinants of FDI into oil and gas sector of Nigeria. The results of the analyses show that the influence of petroleum investment allowance and tax paid on FDI in the oil and gas sector in Nigeria is negative and not significant. This result indicates that tax incentives do not significantly determine FDI in oil and gas sector in Nigeria in terms of petroleum investment allowance and tax paid. In fact they move in opposite direction, that is, as these incentives are going up FDI is declining and vice versa. The policy implication of these findings is that tax

incentives are not necessary to attract FDI in the oil and gas sector. Therefore, this study recommends that Nigeria should review her tax incentives policy towards attracting FDI in non-oil sectors of the economy where the incentives are actually required. In addition, there should be continuous tax reforms to allow for competitiveness in the global investment arena.

Keywords: Foreign Direct Investment; Globalisation; Oil and Gas; Tax incentives.

1. INTRODUCTION

1.1 Background to the study

The federal government of Nigeria developed some tax incentives for various sectors of the economy which includes oil and gas sector, as part of the efforts to provide an enabling environment, that is conducive to the growth and development of industries, and encouragement of Foreign Direct Investment (FDI). However, the tax sensitivity of FDI has important policy implications because the objective is to attract FDI in the development process of the country.

Two fundamental issues concerning FDI are critical. First, are the determining factors of FDI in a typical host country and secondly, are the factors under the control of the host country that are not subjected to the manipulations of FDI countries. These fundamental issues are widely discussed in the literature. For instance, Morriset (2003) argues that tax incentives are a poor instrument for compensating for negative factors in the country's investment climate. Buettner and Ruf (2005); Edmiston, Mudd and Valev (2003); Shah and Slemrod (1991) argue that government often seek to attract FDI by offering tax incentives for firms, but there seems to be a limited evidence for tax incentives justification because the effects in most countries are either small or inconsistent.

Edmiston, Mudd and Valev (2003) states that there is no complete story because at times some FDI receive a windfall from tax incentives as they would still have invested without it. Whatever the case may be, for tax incentives to be worth it in attracting FDI, the tax expenditure of the incentive must be offset by improved developmental opportunities such as improved Gross Domestic Product (GDP) and higher tax revenue. Adelegan

(2009); Ayanwale (2007); Nwankwo (2006) state that FDI in Nigeria is mostly in oil and gas sector. If this is the case, why is FDI mostly in this sector in view of the fact that Nigeria is an oil rich country?

It is also of concern that FDI in oil and gas sector has not translated into better life for Nigeria citizens and yet expected revenue continues to dwindle in view of the additional costs of tax incentives.

“Looking at Nigeria and its oil economy, there is nothing to show in the life of the masses of the people that the country is an oil-producing nation. With a crude oil production of about 2.5 million barrels per day and an export of over 2.3 million barrels per day, one would ordinarily expect some positive impact of the oil wealth on the economy and the people. But available statistics prove the contrary. For instance, Nigeria has what has been described as a disappointing level of economic development with a GDP of about \$45 billion in 2001 and a growth rate of 3.3 per cent” (Ogunmupe, 2012, p.3)

This situation does not seem to improve over time, could it be that there are some leakages somewhere along the line that attention has not been focused? Why is it that the Nigeria's share of FDI in Africa is low despite tax incentives? (Appendix 1). This study attempts to unravel some of these puzzles.

“Macroeconomic data on growth, poverty, and living standards during the last decade have been rather puzzling. On the one hand, the country appeared to be experiencing strong economic growth averaging 7% annually, which was particularly concentrated in the pro-poor areas of agriculture and trade. On the other hand, the national per capita poverty rate remained very high at more than 60% of the population, with little evidence of recent progress in poverty reduction. The recent re-basing of the national accounts, which increased estimated GDP to \$509 billion, making Nigeria the 26th largest economy in the world, brought further attention to this puzzle. How could a country of the size and wealth of Nigeria have poverty rates much higher than in surrounding countries like Niger and Benin Republic? ” (Litwack, 2014, p.3)

This study follows the trend in the literature. For instance Erdal and Tatoglu (2011) argue that the locational determinants of FDI include host government policies. Therefore, this study focuses on host country policies on FDI attraction as viewed from the perspective of tax incentive policy. Buettner and Ruf (2005) argue that unobserved local determinants of location choice are time-invariant. This study uses a sample that covers the period 2008 to 2012.

Five issues distinguish this study. First, it covers an economic sector of oil and gas in an oil-rich country where FDI is prominent and yet citizens suffer from abject poverty. Second, it is an empirical evaluation of the tax incentives as determinants of foreign direct investments (FDI) in the oil and gas sector in Nigeria. Third, it contributes extensively to the existing body of knowledge by employing a sound methodological approach to test the hypotheses formulated for the study. Fourth, it focuses on a transitional economy which has not been adequately covered in existing studies. Fifth, it points to the need to reverse the trend of poverty in Nigeria through its recommendations. It is expected that tax incentives would not be a significant determinant of FDI in the Nigerian oil and gas sector that is rich in the raw material required.

1.2. Statement of the problem

Tax incentives usage in attracting FDI results into a tax revenue reduction inform of tax forgone. Ironically, this may be counter-productive if care is not taken. Otusanya (2011) argues that multinational companies use a lot of tax avoidance tactics to avoid tax in Nigeria. Also, some scholars have argued that tax incentives leave a country worse off in terms of reduced tax revenue (Buettner and Ruf, 2005; Morriset, 2003; Shah and Slemrod, 1991). The question is whether or not the new investment would have come to the country if it had offered incentive or none at all. The more worrisome is that despite the attraction of FDI into the oil and gas sector, Nigeria which is the 6th largest oil producing country in the World is at the same time the one of the poorest country in the world. Litwack (2014) argues that Nigeria with about 170 million population falls among countries with extreme poverty, whose over 70% population live on \$1.25 (N200) or even less per day. Hence, it appears that the economy does not reap a net gain because there would still be FDI without the sacrifice of tax incentives.

Unfortunately, the continuing implementation of tax incentives has posed some difficulties in tax administration and requires well developed accountability system. Organisations for Economic Cooperation and Development (OECD) (2006); Morisset (2003); United Nations Conference on Trade and Development (UNCTAD) (2000) state that tax incentives have many costs , one of such is the difficulty of its effective administration. The problem of abject poverty which might be due to treasury revenue losses based on administrative costs of tax incentives, illustrates the need for this study.

1.3 Aim and objectives of the study

The aim of this study is to evaluate empirically tax incentives as determinants of foreign direct investments (FDI) in the oil and gas sector in Nigeria. This is done by examining formal guidelines and requirements in this regard with the objective of developing a framework for assessing tax incentives influence on FDI. In order to achieve this cardinal objective, this study is specifically designed to:

- i. verify if petroleum investment allowance is a determinant of FDI in oil and gas sector in Nigeria.
- ii. examine the influence of tax paid as a determinant of FDI in oil and gas sector in Nigeria.

To achieve these specific objectives, the following answerable questions are raised:

- i. how is petroleum investment allowance a determinant of FDI in oil and gas sector in Nigeria?
- ii. To what extent is tax paid as a determinant of FDI in oil and gas sector in Nigeria.

1.4 Hypotheses

The following hypotheses are formulated in order to provide empirical answers to the research questions raised. They are stated in the null form.

Hypothesis 1

Ho₁: There is no significant relationship between petroleum investment allowance and FDI in the oil and gas sector in Nigeria.

Hypothesis 2

Ho₂: There is no significant relationship between tax paid and FDI in the oil and gas sector in Nigeria.

This study is important in understanding which specific features of the tax system are necessary for the location of FDI. According to Buettner and Ruf (2007) several empirical studies have investigated the influence of taxes on FDI, however, most studies have focused on the volume and distribution of FDI rather than on the underlying attraction, thereby leaving a gap in the literature. This study fills this gap by evaluating the individual tax incentives as a determinant of FDI. This study is useful to policy makers and investors for decision making. Academics and students would find it useful.

This study covers foreign direct investments in the oil and gas sector in Nigeria as affected by the *Constitution of the Federal Republic of Nigeria (First Alteration), Act 2010, Petroleum Profits Tax Act (PPTA) CAP P.13 LFN 2004, Nigerian National Petroleum Corporations Act No.33 of 1977 chapter 320 LFN 1990, Nigeria LNG (Fiscal Incentives Guarantee and Assurances Amendment), Act 113 of 1993, Industrial Development (Income Tax Relief) Act, CAP 17, LFN 2004 - Pioneer Status and Federal Inland Revenue Service (Establishment) Act No. 13 LFN 2007*. Therefore, tax regulators, law and policy makers will find this study useful in the area of developmental reforms and policy review. Multinationals and home countries shall have information on other avenues to explore in order to establish FDI enterprise in Nigeria.

The focus of this study is rested on the role of tax incentive in the attraction of FDI in the oil and gas sector in Nigeria. It evaluates the extent to which tax incentives determine the inflow of FDI in the oil and gas sector in Nigeria if any, with particular reference to tax incentives provided by the federal government. The secondary data were manually gathered from the companies' annual tax returns filed with the Federal Inland revenue service for 2008 to 2012.

1.5 Limitation of the study

This study is based on secondary data. The study recognises that secondary data usually generate mixed feelings on methodological issues such as the effect of ignoring the tone of voice in interview, or the feeling of respondent in questionnaire in the analysis. Thus, it is only possible to discuss evidence which is available in the public domain, in other words materials that can be gathered from secondary data and regulatory reports concerning foreign direct investment flow into Nigeria. For this reason, this study does not pretend to offer any exhaustive analysis, but instead provides some in order to show how FDI respond to tax incentives in Nigeria. The study provides a statistical interpretation of the results to reduce this limitation.

2.0. REVIEW OF LITERATURE

2.1 Introduction

The use of tax incentive has generated considerable debate about whether or not governments have offered unreasonably large incentives to attract firms to invest in their area. According to Morisset and Pirnia (1999) taxes affect the net return on capital and should, at least in the mind of numerous policy-makers, influence the capital movements between countries. For this reason, the early literature attempted to evaluate if a generous tax policy could compensate for other obstacles in the business environment and, thus, attract multinational companies in response to the trend in globalisation (Oyeranti, Babatunde, Ogunkola and Bankole, 2011; Morisset and Pirnia, 1999).

FDI in oil and gas sector in Nigeria has grown considerably as evidenced by the number of high profile FDI in oil and gas sector such as Shell Petroleum Plc, Mobil Oil Nigeria Plc, MRS Oil Nigeria Plc, and Total Nigeria Plc. The global FDI competitive trend has to be offset by the increasing pressure that governments face to harmonise tax policies. Another important factor has been the recognition that tax policies of the home and host countries are interconnected and that this link influences the behaviour of foreign direct investments.

This paper argues that there is need for more research to give evidence on the debate so far, in a transitional economy. Literature review was carried

out to determine the extent of tax incentive as an attraction of FDI in oil and gas in Nigeria in relation with political economy theory of globalisation and the theory of capitalism.

2.2 Theoretical framework

This study adopts the political economy theory of globalisation and the theory of capitalism to explain the implication of the use of tax incentives to attract FDI. Given the central role of investors' interest in his pursuit of profit for the purpose of accumulating capital in the sustenance of the interest of shareholders, the corporation looks for markets and it is attracted to the host country to satisfy its pursuit of profits tendencies hence FDI (Dunning, 2011; Otusanya, 2011; Bolderman, 2007; Hausman, Rodrick and Valesco, 2004; Mirrlees, 1971). This attraction may be achieved by the host country in sacrifice of tax incentives in order to maximize political economic gains of globalisation ideology such as job creation, advancement in technology and economic growth (Werner and Psychopedis, 2000; Collins, 1980). Adeola (2003) argues that within the oil value chain, refined and processed products have higher value added and so bring more economic benefits than crude petroleum. They also embody a higher degree of technological sophistication and require more specialised skills. This requirement for technological sophistication and specialised skills necessitates the encouragement of FDI.

Fakile and Adegbile (2011) argue that the effectiveness of tax incentives is likely to vary depending on a firm's activity and its motivations for investing abroad and as such must be structured properly. Morisset (2003) states that to achieve the gains of tax incentives for national development, developing countries must structure tax policies in a way so as to attract foreign investment, without creating a negative impact in the domestic economy. This is to ensure that they do not fall into a harmful tax competition against other countries. The motivational attitude of investors is explained in the theoretical framework guiding globalisation and economic theories of development in the area of FDI and tax incentive.

Therefore, the economic theory of low taxes and tax cuts for business gains aligns with the theory of political economy of globalisation to attract FDI. According to Werner and Psychopedis (2000) globalisation considers nation

states boundaries as less important in doing business and encourages the globalisation of national economies for the purpose of transnational economic flow for multinational businesses.

A firm should acquire a controlling share in a foreign firm to become a multinational company, this requires adequate capital flow in form of FDI. Also the decision for FDI attraction to the multinational may be influenced by the availability of tax competition in the host country in the area of location, volume and scope of business. This is because FDI tends to be sensitive to tax rates differences in the host countries (Desai, Foley and Hines, 2003).

2.3 Tax incentives as determinants of FDI in oil and gas sector

The tax sensitivity of FDI has important policy implications which require attention in the policy formulation. However, Edmiston, Mudd and Valev (2003) and Morisset, (2003) argue that tax incentives if given to the wrong firms are ineffective in stimulating FDI.

In order to attract FDI, the Nigerian Government have in place a number of investment incentives for the stimulation of private sector investment from within and outside the country. "While some of these incentives cover all sectors, others are limited to some specific sectors. The nature and application of these incentives have been considerably simplified. The incentives include tax holidays, initial capital allowance, and free duty on equipment" (Fakile and Adegbile, 2011, p. 17).

Morisset (2003) and Shah and Slemrod (1991) state that incentive regimes generally impose a large administrative burden, if this should be the case, they must be more than marginally effective to cover the costs of their implementation and produce a net benefit. Discretionary regimes, which rely on case-by-case evaluations, are especially difficult to administer. These regimes result in delay and uncertainty for investors, which can increase the cost of investment. They have also led to significant corruption, effectively screened out desirable investments, and undermined sound policymaking and the development of competitive markets.

2.4 Types of tax incentives in oil and gas industry in Nigeria

The Industrial Development (Income Tax Relief) Act, CAP 17, LFN 2004 - Pioneer status, the tax incentives applicable in oil and gas industry in Nigeria include tax holidays for Pioneer Status (PS), Accelerated Capital Allowance

(ACA), Investment Tax Credit (ITC) or Petroleum Investment Allowance (PIA). ITC are enjoyed by petroleum companies that sign agreement of petroleum activities before 1998 while PIA is claimed by those who signed after 1998. All Joint Venture Companies (JVC) claim PIA (Seeappendixes 2 and 3).

According to Industrial Development (Income Tax Relief) Act, CAP 17, LFN 2004, pioneer companies enjoy tax relief period of three years which can be extended to a maximum period of five years. Dividends paid out of pioneer profits during the tax relief period are tax-free. Also, any aggregate loss incurred during this period can be carried forward against future trading profits of the same trade or business for a maximum of four years.

During the pioneer period, a company must not carry on any business other than its pioneer business otherwise profits from such other businesses will be taxed. In such instances, section 10 of the Act, provides, that a three year- tax holiday is available for companies that are granted pioneer status, and upon application, subject to satisfactory performance on such status, an additional two years may be granted to the company. In most cases, companies are free from tax obligations in this period.

Petroleum profit tax rate is enjoyed by upstream oil and gas companies at the rate of 85% of chargeable profit. Profits are calculated based on petroleum operations within each accounting period. Profits include proceeds of sale of chargeable oil sold by the company during that accounting period, value of all chargeable oil disposed of by the company during that accounting period, value of all chargeable natural gas in that accounting period as determined in accordance with the 4th Schedule to the Act and all income of the company for that period incidental to and arising from one or more of its petroleum operations.

The assessable tax is calculated on the chargeable profits at the rate of 85% or 67.75%, applicable to companies which have not commenced sales or bulk disposal of chargeable oil by continuous production or sales, in order to enable them amortise their pre-production expenditure (usually for a period of 5 years) after which the rate of 85% shall apply.

Downstream companies enjoy companies' income tax at the rate of 30%. Companies Income Tax ACT, CAP 60. LFN 1990 as amended in Companies Income Tax (Amendment)ACT 2007 stipulates thatCompanies' Income Tax (CIT)is levied on profits accruing in, derived from, brought into orreceived in Nigeria.Any company doing business in Nigeria, whetherresident (registered in Nigeria) or non- resident (foreign company registered outside Nigeria) is liable for companies' income tax in Nigeria.

RESEARCH METHODOLOGY

3.1 Research design

This research has no control over the data used, thus the study is anchored on carrying out a survey. The structure of its process and procedure is therefore, descriptive which belongs to the generic family research design type called cross sectional research design under survey design. This research design was adopted in this study because it supports"the structuring of the investigation aimed at identifying variables and their relationships to one another" (Asika, 2008, p. 27).

3.2The study population

The population of this studyis all the twelveoil and gas FDI companies in the upstream sector as shown in the records of Federal Inland Revenue Services as at 2013.

3.4 Sampling method

Purposive sampling method was used in view of the small population, hence, only twelve upstream and five downstream companieswere adequately analysed based on availability of the required data on the companies.All the data used were obtained by utilising the annual tax returns of the companies

for 2008 to 2012 which shows the type of tax incentives enjoyed by each company.

3.5 Statistical method of data analysis

The statistical method used includes frequencies and descriptive statistics. Karl Pearson coefficient of correlation method of analysis was adopted. It is the most widely used in practice to measure the degree of correlation between two series. Gupta (2009) and Waller (2008) argue that Pearson, r , when squared measures the extent to which one variable accounts for correlation with the other but it does not mean it causes the variable to occur. It is typically denoted by r which is a measure of the correlation (linear dependence) between two variables X and Y , giving a value between +1 and -1 inclusive. It is widely used in the sciences as a measure of the strength of linear dependence between two variables.

Karl Pearson correlation coefficient is adopted used in this study because of its qualities that match the expectations of this study. The data used in testing the hypotheses were generated through the aid of Statistical Package for Social Sciences (SPSS) version 17.0.

3.4 Conceptual underpinning and measurement of the variables

Two categories of variables were used in this study; they are the dependent variable which is FDI in oil and gas and the independent variables that are the FDI attracting measures in the form of tax incentive indicators. The FDI variable is the annual qualifying expenditure upon which the tax incentives were based. The incentives of attraction were viewed from two dimensions of tax incentives of petroleum investment allowance and tax paid. The dependent variables used are petroleum investment allowance and tax paid which are common to both upstream and downstream sectors of oil and gas in Nigeria.

Buettner and Ruf, (2007); Edmiston, Mudd, Valev, (2003) used effective tax rate. Thus, the choice of the variables used in this study was informed by previous studies such as Ayanwale (2007); Buettner and Ruf (2005). All the

variables were extracted from the actual performance figures reported in the Companies' annual tax returns for 2008 to 2012.

The independent variable FDI is the annual qualifying expenditure upon which the tax incentives were based. The dependent variables are measured as Petroleum investment allowance (PIA) was measured as enjoyed by each company. Tax paid is measured as the average annual tax paid for 2008 to 2012 by the companies. Petroleum profit tax rate of 85% of chargeable income applies to the upstream sector while company income tax rate of 30% of chargeable income applies to the downstream sector.

4. 0. DATA ANALYSIS AND RESULT DISCUSSIONS

The composition of the FDI used is analysed in Table 4.1 as per Appendix 4.

Table 4.1: FDI oil and gas companies used in this study

	Frequency	Percent	Cumulative Percent
Valid UPSTREAM	12	70.6	70.6
DOWNSTREAM	5	29.4	100.0
Total	17	100.0	

Source: Field Survey 2013

Table 4.1 shows twelve (12) or 70.6% upstream and five (5) or 29.4% downstream companies that were used for this study. In Table 4.2, the study uses mean and standard deviation to measure the dispersion, deviation or how far an average is representative of the mass. The mean deviation in the descriptive statistics in Table 4.2 is used to explain the reliability of the variables.

Table 4.2: Descriptive Statistics of the research variables used in this study

Item No.	Description	N	Minimum	Maximum	Mean	Std. Deviation
1.	FDI	17	5.13	9803.00	1319.3867	2467.37466
2.	Petroleum Investment Allowance	17	.00	128.13	34.5225	45.99953
3.	Tax paid by FDI Oil & Gas	17	.00	4132.35	1120.3433	1109.41977
	Valid N (listwise)	17				

Source: Field Survey 2013

Table 4.2 indicates that the petroleum investment allowance records a mean of 34.52; tax paid during the period under consideration records a mean of 1120.34 on the average.

4.1 FDI and petroleum investment allowance

The first research question aims to determine the extent to which FDI enterprises are attracted to oil and gas sector in Nigeria in response to the petroleum investment allowance. Table 4.2 item 2 shows the result of the descriptive statistics which indicates a low mean of 34.52 for petroleum investment allowance. This result, when compared with the maximum mean of 128.13, shows a huge difference of 93.61 representing 207 percent. Also, the standard deviation is high at 45.99. Therefore, petroleum investment allowance is not a determinant of FDI in oil and gas sector in Nigeria to a large extent.

4.2 FDI and tax paid

The second research question sought to determine the extent to which FDI enterprises are attracted to oil and gas sector in Nigeria in response to tax paid. Item 3 in Table 4.2 predicts a mean score of 1120.34 for tax paid, this is far from the maximum of 4132.35 by 3012.01. The deviation from the mean is also high at a standard deviation of 1109.42. Therefore, the result suggests that tax paid is not a determinant of FDI oil and gas in Nigeria.

4.3 Test of hypotheses

The independent variable is regressed against the dependent variable FDI to obtain the Pearson correlation statistics as shown in Table 4.3.

Table 4.3 Pearson Correlations to determine significance of relationship between FDI and tax incentives items

		FDI Oil & Gas	Petroleum Investment Allowance	Tax paid
FDI Oil & Gas	Pearson Correlation	1	-.155	-.176
	Sig. (2-tailed)		.552	.499
	N	17	17	17
Petroleum Investment Allowance	Pearson Correlation	-.155	1	.532*
	Sig. (2-tailed)	.552		.028
	N	17	17	17
Tax paid	Pearson Correlation	-.176	.532*	1
	Sig. (2-tailed)	.499	.028	
	N	17	17	17

*. Correlation is significant at the 0.05 level (2-tailed).

Source: Field survey 2013

4.4 Hypothesis 1

H_0 : There is no significant relationship between petroleum investment allowance and FDI in the oil and gas sector in Nigeria.

This hypothesis is proposed to empirically test the relationship between petroleum investment allowance and its capacity to drive FDI into Nigerian oil and gas sector. Table 4.3 predicts a non-significant, negative relationship

between FDI oil and gas and petroleum investment allowance at $r = -.155$ $p > 0.05$. The extent of the opposite direction relationship shows that they are wide apart at $(-.155)^2$ or $.02$. Therefore, the study fails to nullify the null hypothesis and conclude that there is no significant relationship between petroleum investment allowance and FDI in the oil and gas sector in Nigeria.

4.5 Hypothesis 2

H₀₂: There is no significant relationship between tax paid and FDI in the oil and gas sector in Nigeria.

This hypothesis is proposed to empirically test the relationship between tax paid and its capacity to account for FDI into Nigerian oil and gas sector. Table 4.3 predicts a non-significant, negative relationship between FDI oil and gas and tax paid at $r = -.176$ $p > 0.05$. The extent of the opposite direction relationship shows that they are apart at $(-.176)^2$ or $.03$. Therefore, the study fails to reject the null hypothesis and conclude that there is no significant relationship between tax paid and FDI in the oil and gas sector in Nigeria.

5. 0. SUMMARY, CONCLUSIONS AND RECOMMENDATIONS

5.1 Summary

This study is designed to provide answer to two research questions and test two hypotheses. It provides empirical evidence in support of the findings. Objective number one is to verify if petroleum investment allowance is a key determinant of FDI into oil and gas sector in Nigeria, this study predicts a not significant, negative relationship between FDI and petroleum investment allowance. The second objective is to examine the influence of tax paid as a determinant of FDI in oil and gas sector in Nigeria. This study finds a not significant, negative relationship between FDI and tax paid.

The empirical results imply that the tax environment in Nigeria is not a determinant of FDI in oil and gas with regards to petroleum investment allowance and tax paid. Hence, the host country is unable to use tax incentive to achieve economic development in satisfaction of political

economy theory of globalisation (Werner and Psychopedis 2000; Collins 1980).

5.2. Conclusion

This study concludes that petroleum investment allowance and tax paid are not determinants of FDI in the oil and gas sector in Nigeria. This implies that tax incentives are additional cost burden to Nigeria which is not necessary. This conclusion has provided a reason to dig into the role of tax incentives in the poverty alleviation policy of Nigeria.

5.3 Recommendations

Based on the findings from this study, the following recommendations are made:

- i.* Nigeria should review her tax incentives policy towards focusing on areas where they are required, in order to facilitate the inflow of FDI into other neglected sectors of the country.
- ii.* There should be constant improvement on tax incentive administration from time to time, to avoid highjack of tax incentives that would have been attracted for other reasons by FDI. This will protect the host country's real wealth.
- iii.* There should be periodic awareness campaign of tax incentives to stakeholders such as investors, to attract them to the various sectors of the economy. This will improve the share of Nigeria in FDI. (Appendix 1)
- iv.* It is in the interest of good governance in Nigeria to have disciplined approaches to decisions on policy and implementation. The willingness of tax administrators and policy makers to pursue the approaches advanced in this study provides more 'open' government in order for pioneer status tax incentives policy to achieve the desired effect.

5.4 Contribution to knowledge

A major contribution of this study is that it provides an insight into the determinants of FDI in the oil and gas sector in Nigeria. This study

contributes to literature in its consideration of individual tax incentives rather than collective tax incentives as determinants of FDI in oil and gas sector.

This study creates awareness as to the performance of government tax policies in economic development. It provides a framework for discussing, studying and analysing tax incentives as determinants of FDI in a transition economy in Nigeria. The outcome of this study shall provide reference for the local and international business communities and company directors. This is available to future accounting and finance researchers. This would enhance the comparability of future research findings.

5.5.Suggestion for further research

Tax incentive as a determinant of FDI is a major focus of this study, it is suggested that the other likely determinants of FDI such as the availability of needed natural resources like crude oil, of the host country should be covered in future.

References

[Adeola, F. \(2011\).Forecast of Investment Climate in Nigeria in the Next Decade.](#)

Retrieved on August 2, 2012 from <http://www.cybershuulnews.com>

Asika, N. (2008). *Research Methodology in the Behavioural Science*. Nigeria
Longman Nig. Plc.

Ayanwale, B. (2007). FDI and Economic Growth: Evidence from Nigeria. *The African*

Economic Research Consortium.

Bolderman, L. (2007). *THE CULT OF THE MARKET Economic Fundamentalism and its*

Discontents. Australia. The Australian National University E. Press.

Buettner, T. and Ruf, M. (2007). Tax incentives and the location of FDI: Evidence

from a panel of German multinationals. *Int Tax Public Finance* (2007), 14.

Collins, R. (1980). Weber's last theory of Capitalism: A systemization. *American*

Sociological Review, 45

Companies Income Tax ACT, CAP 60. Law of the Federation of Nigeria(1990).

Daily independent (2015). World Bank report on poverty in Nigeria. Retrieved on May 10,

2015 from <http://www.dailyindependennigeria.com>

Desai, M.A., Foley, C.F., Hines, J.R. (2003). Chains of Ownership, Regional Tax

Competition, and Foreign Direct Investment, *National Bureau of Economic Research*

Digest.

Dunning, H.D. (2011). The institutional and cultural determinants of foreign direct

investment in transition countries. *Journal of research in international business and*

management 1 (2).

Edmiston, K.D, Mudd, S. and Valev, N.T. (2003). Incentives Targeting, Influence Peddling

and Foreign Direct Investment. Retrieved on August 2, 2012 from

<http://www.aysps.gsu.edu/isp/files>

Fakile, A .S. and Adegbile, F.F. (2011). Tax Incentives: Tool for Attracting Foreign Direct

Investment in Nigerian economy. *International Journal of Research in Commerce and Management*.2 (2).

Erdal, F. and Tatoglu, E. (2011).The relationship between foreign direct investment and

exports from the technology sector in Costa Rica.Retrieved on October10, 2012 from

<http://www.readperiodicals.com>

Gupta, S. P. (2009).*Statistical Methods*. New Delhi.Sultan and Sons Educational Publishers.

Klemm, A. (2009).Causes, Benefits and Risks of Business Incentives. Retrieved on March

17, 2014 from [http:// www.imf.org](http://www.imf.org).

Litwack, J. (2014). Nigeria Economic Report: Improved Economic Output in 2014 and

prospects for continuing growth look good. Retrieve on May 10, from

<http://www.worldbank.org>

Mirrlees, J. (1971). An exploration in the theory of optimum income taxation. *The review of*

Economics studies, 38.

Morisset, J. (2003).Using Tax Incentives to Attract Foreign Direct Investment. Retrieved on

July 20,2012 from <http://www.rru.worldbank.org.documents>

Morisset, J. andPirnia, N. (1999).How Tax Policy and Incentives Affect Foreign Direct

Investment: A Review.Retrieved on July 20, 2012 from

<http://www.rru.worldbank.org.documents>

Nigerian Investments Promotion Commission Act CAP No.117 (1995). Law of the Federation of Nigeria.

Nwankwo, A. (2006). The Determinants of Foreign Direct Investment Inflows (FDI) in Nigeria. Retrieved on July 21, 2012 from [http://www.gibe.us/.../...](http://www.gibe.us/.../)

Ogunmupe, B. (2013). Nigeria's position among OPEC countries. Retrieved on May 10, 2015, from <https://www.google.com.ng>

Otusanya, O.J. (2011). The role of multinational Companies in tax evasion and avoidance:

The case of Nigeria. *Journal of Critical Perspectives in Accounting*, 22(3).

Oyeranti, O.A., Babatunde, M.A., Ogunkola, E.O., Bankole, A.S. (2011). An analysis of

China-Nigeria Investment relations. *Journal of Chinese Economic and Foreign Trade Studies*, 4(3).

Shah, A. (2005). *Fiscal Incentives for Investment and Innovation*. Oxford. Oxford University Press.

Shah, A., Slemrod, J. (1991). Do Taxes Matter for Foreign Direct Investment? *The World Bank Economic Review*, 5(3).

United Nations Conference On Trade and Development (UNCTAD) (2000). Tax Incentives and Foreign Direct Investment –A *Global Survey*. Retrieved on July 20, 2012 from

<http://www.unctad.org/es/docs/itelpcmisc3>

Werner, B. Psychopedis, K. (2000). *Globalisation, Ideology and Critique*. Athens. Petgrave

Macmillan.

APPENDIXES

APPENDIX 1 NIGERIA SHARE OF FDI INFLOW IN AFRICA - 2005-2011 (\$MILLION)

YEAR	2005	2006	2007	2008	2009	2010
Africa	38,160	46,259	63,132	73,413	60,167	55,040
Nigeria	4,978	4,898	6,087	8,249	8,650	6,099
% of Nigeria share in Africa	13	10.58	9.64	11.23	14.37	11.08

Source: UNCTAD World Investment Report 2010

APPENDIX 2 TAX INCENTIVES IN OIL AND GAS INDUSTRIES IN NIGERIA

S/N	ITEM	PETROLEUM PROFIT TAX	INVESTMENT CAPITAL ALLOWANCE	INVESTMENT TAX CREDIT	ROYALTY	TAX HOLIDAY	GUARANTEED MINIMUM MARGIN

1	PETROLEUM	30% P.A	Accelerated capital allowance	5% On shore 10% off shore in up to 10m 15% for 100m-200m	Graduate royalty rate		US \$2.50billion
2	GAS PRODUCTION PHASE	30% P.A	20% per annum (first 4 years) 19% per annum (fifth year) 1% in the books	5%	7% on shore 5% off shore		
3	GAS TRANSMISSION AND DISTRIBUTION	As above	As above			As under pioneer status.	
4	LNG PROJECTS	45% P.A	33% per year for the first three year 1% retained in the books	10%	7% onshore 5% offshore		
5	GAS EXPLOITATION (UPSTREAM OPERATION)		Subject to PPT ACT & revised Memorandum of Understanding				
6	GAS UTILISATION (DOWNSTREAM OPERATION)	30% P.A	15% which shall not reduce the value of the asset.			5 years	
7	GAS TRANSFER	0%	15%		0%		

Source: Federal Ministry of Trade & Investment 2013

APPENDIX 3

TAX ALLOWANCES FOR OIL AND GAS UNDER PIONEER STATUS IN NIGERIA

S/N	ITEM	PETROLEUM PROFIT TAX	CAPITAL ALLOWANCE	INVESTMENT TAX CREDIT	TAX HOLIDAY	CAPITAL REPARTRATION
1	Petroleum	30% P.A	20% P.A	5%	-	-
	Gas	30% P.A.-	15 % which shall not reduce the value of the asset	-	5 YEARS	-
	Oil & Gas free zone	-	-	-	-	100% OF CAPIATL AND PROFIT. NO FX REGULATION

Source: Federal Ministry of Trade & Investment 2013

APPENDIX 4

LIST OF COMPANIES USED IN THE STUDY

UPSTREAM COMPANIES

1. CHEVRON NIGERIA LIMITED
2. MOBIL PRODUCING NIG. UNLIMITED
3. TOTAL E&P LTD.
4. NIGERIAN AGIP OIL COMPANY LTD.
5. PHILLIPS OIL
6. SHELL PETROLEUM DEVELOPMENT COMPANY OF NIGERIA LIMITED
7. STARDEEP WATER PETROLEUM
8. SOUTH ATLANTIC PETROLEUM LTD.
9. NIGERIA AGIP EXPLORATION
10. ADAX PETROLEUM DEVELOPMENT NIGERIA LTD.
11. ADAX EXPLORATION NIGERIA LTD
12. SNEPCO

DOWNSTREAM COMPANIES

- 13. MOBIL OIL NIGERIA PLC
- 14. TOTAL NIGERIA PLC.
- 15. SHELL NIGERIA GAS LIMITED
- 16. NIGERIA LNG LIMITED
- 17. BRASS LNG LIMITED

TAX REVENUE AND ECONOMIC GROWTH IN NIGERIA FROM 1980-2013

**Etim Osim Etim (B.sc, MBA, M.sc, ACA, Doctoral Student)
Department of Accounting University of Uyo.**

AND

**Professor Austin Nweze (FCA)
Department of Accounting, Enugu State University of Science and
Technology**

ABSTRACT

The study examines the long-run relationship between tax revenue and economic growth in Nigeria from 1980 to 2013. This was motivated by the fact that taxation is a key component of any country's fiscal policy framework meant to discretionally enhance economic growth and stability. But in Nigeria, tax revenue has not assumed its prominent role in this regard due to excessive dependence on oil and other non-tax revenue, and because of the prior assumption that taxes de-motivate investments and entrepreneurship. The study, therefore, investigates this relationship using 1980-2013 data obtained from the central bank of Nigeria and Federal Inland Revenue Services (FIRS). Descriptive research methodology was used in conjunction with inferential statistics of correlation and regression analyses. To ensure that regression results were not spurious, diagnostic analyses to test for stationarity was carried out on the variables using Augmented Dickey-Fuller (ADF) unit root test. Furthermore, to ascertain the presence of long-run relationships among variables, Johansen co-integrating test with the Trace and Eigen Value Statistics were adopted. To correct for the short run disequilibrium among variables, the Error Correction Mechanism (ECM) was used. Finally, in order to determine whether a casual relationship exists between tax revenue and economic growth and the direction of such a relationship, the Granger Causality test was used. The results of the analysis reveals mixed growth performances for all the variables studied and positively correlation between and among the variables. It was further revealed that tax revenue components influence

economic growth although at varying degrees. One strong outcomes of the study is that CIT, PIT and VAT does not granger cause economic growth, that is are poor growth drivers, while PPT, CED ad EDT play vital role in that regard. It was, therefore, recommended that the government should handle lax related matters with tact to encourage investment, entrepreneurship and innovation, pay attention to developing infrastructures, reform taxes that have least effect on economic growth potentials as well as ensure accountability and transparency in the utilization of tax revenue.

Keywords: Tax revenue, Infrastructure, Investment and Entrepreneurship

1.0 INTRODUCTION

Nigeria practices a federal system of government; hence its fiscal operations adhere to the same principle. The fiscal power of government is based on a three-tier tax structure divided among the various political jurisdiction (Federal, states and Local Governments) each constitutionally granted different tax jurisdiction. As of 2013, about 40 different taxes and levies were shared by the three tiers of government (Odusola, 2006; Offiong, 2013), a fact which has serious implications on how the tax system is managed.

Nigeria, as a developing country; unlike most developed economies of the world, is characterized by a broad base for direct taxes liability covering a vast majority of citizens and firms. It is therefore, confronted with social, political and administrative difficulties in establishing a sound taxation system. Consequently, the neglect of many sources of tax revenue and a vast majority of those found in the informal sector of the economy are mostly not covered by the tax regime; the impact being shortfall in projected tax revenue and the persistent fiscal deficit which has become a recurring feature of public sector financing in Nigeria over the past four decades.

Globally, government is saddled with the responsibility of providing some basic infrastructures for her citizens. Among these are the provision of schools, hospitals, roads, railways and social welfare services, the security of life and properties of the citizens of the country against external and or internal aggression (Popoola, 2009). Miller and Oat (2009) noted that due to the inefficiency of the private market, the provision of public goods such as security of life and property which the public might not be prepared to pay for directly, are left in the hands of the government. In Nigeria, public

expenditures have been expending for decades causing both domestic and external borrowing. With the widening public expenditure, more revenue is needed by the government to meet these expenditures.

The nexus between tax revenue and economic growth is long recognized in the literature. The United Nations (UN) asserts that, to achieve rapid economic growth and development, developing countries must have to increase their domestic revenue through taxation. Several studies (UN, 2005; Popoola, 2009; Adegbe & Fakile, 2011; Onefeiwu, 2012) have attempted to identify the linkage between tax revenue and economic growth. The underlying premise has always been that when the government prudently apply tax revenue on the provision of public infrastructures, create enabling environment for business to thrive, economic growth is enhanced. There is therefore a growing recognition that the formulation and implementation of macroeconomic management proposals, most especially for economic reforms, should explicitly recognize the nexus between tax revenue and economic growth.

The International Monetary Fund (IMF) (2010) emphasize that developing countries, must recognize that taxation is an important mainstream priority for growth. This recognition reflects the focus of interest on mobilizing domestic resources in the form of taxes as a foundation to sustainably fund essential public services. It also reflects increasing recognition that development of an effective, efficient, equitable tax system is a central pillar of state building and governance (Organization for Economic Cooperation and Development (OECD, 2013). Thus, in many developing countries, tax policy is used as the principal instrument to correct fiscal imbalances (Ahmed & Stern, 2011; Rao, 2005). A country's tax system is therefore, a major determinant of other macroeconomic indices. Specifically, for both developed and developing economies, there exist a relationship between tax structure and the level of economic growth. This study aims at investigating this relationship using time series data from 1980 to 2013 for Nigeria.

1.1 Statement of the Research Problem: Several studies have identified the lopsidedness of the Nigerian tax system as dominated by oil revenue (Odusola, 2006; Bird, 2008; Diallo, 2009; , Aruwa, 2010; Chimobi and Uche, 2010, Ebeke and Ehrhart, 2010; Abiola and Asiweh, 2012, Akintoye and Tashie, 2013,), and on revenues from primary agricultural products between 1960 and the early 1970s. (Ariyo, 1997; Diallo, 2009,

NTP, 2010) as influencer of economic growth. Over the past five decades, therefore, tax revenue has not assumed a strong role in the country's economic and fiscal management strategy.

More so, studies have revealed that the average ratio of tax revenue to economic growth for developed economies has been on the increase and these changes have been more pronounced in countries with less natural resource endowment than for resource based countries (Martinez-Vazquez, Vulonic & Lui, 2009); and the negative impact of taxes on economic growth particularly direct taxation among developed economies (Ram, 1986; Vartia, 2008; Djankov, Ganser, Ramalho & Shleifer, 2009; Mashkoo, 2010; McBride, 2012). Although the studies above provide useful insight into the relationship between tax revenue and economic growth, most of these studies are conducted in the developed economies less analysis has taken place in developing economy like Nigeria. The few existing studies to the best of our knowledge conducted in Nigeria have focused on the relationship between government fiscal framework (revenue and expenditure) on the whole and economic growth, and short term relationship between the sub-components of tax revenue profile and economic growth (Iyoha & Oriakhi, 2010; Owolabi & Okwu, 2011; Adegbe & Fakile, 2011; Ogbonna & Ebimobowei, 2012); Ilaboye & Mgbame, 2013). This study is motivated by this knowledge gap and the need to curtail the fallacy of hasty generalization arising from the importation of research results from developed economies to address our indigenous issues without first confirming their applicability. Therefore, this study looks at the long-run relationship between Tax Revenue and Economic Growth proxy by Gross domestic product (GDP) in Nigeria from 1980 to 2013.

1.2 Objective of the Study: The main objective of this study is to evaluate the long-run relationship between tax revenue and economic growth in Nigeria from 1980 to 2013.

Specifically, the study seeks to:

- i. determine the effect of tax revenue on economic growth;
- ii. ascertain the direction of causality between tax revenue and economic growth in Nigeria.

1.3 Research Questions

To achieve the stated objectives, the following research questions are raised:

- i. Does tax revenue has any significant effect on economic growth in Nigeria?
- ii. What is the direction of causality between tax revenue and economic growth in Nigeria?

1.4 Research Hypotheses

The following hypotheses are formulated for the study:

- i. There is no significant relationship between tax revenue and economic growth in Nigeria
- ii. There is no causal relationship between tax revenue and economic growth in Nigeria.

1.5 Justification for the study: of concern to accountants, economists, and interested observers in recent times is the rising magnitude of deficits in our public sector. There is therefore a growing recognition that the formulation and implementation of macroeconomic management proposals, most especially tax policies, should explicitly recognize the implications of tax structure on the economy. This is because taxes affect not only government revenue, but also economic efficiency and economic growth. Some government spending (for example, in infrastructure) may actually improve a country's economic efficiency and stimulate growth. But beyond that level, may be detrimental to growth and less productive. These call for transparency and accountability on the country's governance machinery.

2.0 LITERATURE REVIEW

The review of the literature shall cover conceptual framework, theoretical framework and empirical studies. The conceptual framework explains the concept of tax, reasons for taxation, economic growth and other major variables. The theoretical framework underpins relevant theories to the study while the empirical framework reviews relevant previous empirical research works.

The National Tax Policy defines tax as "a financial change or levy imposed upon an individual or legal entity by a state or a legal entity of the

state; it is a pecuniary burden laid upon individuals or property to support government expenditure" (NTP, 2010). It goes on to state that "tax is not a voluntary payment or donation, but an enforced/compulsory contribution, exacted pursuant to legislative authority and is any contribution imposed by the government, whether under the name of duty, custom, excise, levy or other name" (NTP, 2010). The act of assessing, imposing and collecting the various taxes is taxation.

Government imposes tax for many reasons. These include:

- i. To generate needed revenue for financing of government activities,
- ii. To control the economy; as economic stabilizer;
- iii. To redistribute income between the wealthy and less wealthy populace,
- iv. To discourage the consumption of certain goods and protect domestic industries;
- v. To stimulate domestic production, creating employment, and
- vi. To correct balance of payment deficits (Ayuola, 2010; Adegbie & Fakile, 2011; Okafor, 2012).

Generally, taxes are expected to yield enough revenue to finance government expenditures and also achieve macro-economic goals of full employment, acceleration of economic growth, as well as promoting robust public and private sectors. But, the magnitude of government deficit over the decades questions the reliability of tax revenue in achieving the aforementioned objectives.

More so, to achieve the broader objectives of social justice, the tax system of a country should be based on some principles which Adam Smith called canons of taxation. Jhingan (2004), Bhartia (2009) and Osiegbu et. al. (2010) listed the principles of taxation as equality, certainty, convenience, economy, simplicity, productivity, flexibility and diversity.

The Nigerian tax system has come of age giving the fact the colonial masters introduce taxes as early as 1903. The administrative machinery for taxes rest with the Federal Inland Revenue Service (FIRS), States Board of Internal Revenue (SBIR), Local Government Revenue Committees (LGRC) and the relevant Joint tax Boards and Technical Committees. The prevailing tax laws in Nigeria according to Kaibel and Nwokah (2009) and Abiola and Asiwea (2012) include:

- i Personal Income Tax Act (PITAN) CAP P.8 LFN (2004;2011)
- ii Company Income Tax Act (CITA) CAP 60 LFN 1990 (Amended 2014).
- iii. Petroleum Profit Tax Act (PPTA) 2007

- iv. Value Added Tax (VAT) Act No. 102 LFN 1993
- v. Capital Gains Tax Act (AP 42 LFN 1990
- vi. Stamp Duties Act CAP 42 LFN 1990
- vii. Education Tax Act No. 7 LFN 1993
- viii. Information Technology Development Act 2007
- ix. Customs and Excise Management Act 1990 amended 2004 etc.

Economic growth has long been considered an important goal of economic policy and reforms agenda with a substantial body of research dedicated to explaining how this goal can be achieved (Fadare, 2010). Khorravi and Karimi (2010) in their classical studies estimate economic growth to be largely linked to government expenditure which itself is a function of revenue available to the government, accountability and good governance. The emergency of the endogenous growth theory has encouraged the questioning of the role of factors of production in explaining the economic growth phenomenon (Bogdanov, 2010).

Economic growth represents the expansion of a country's potential GDP or output. It has provided insight into why state grows at different rates overtime; and this influence government in her choices of tax rates and expenditure levels that will influence growth rates.

Conceptually, therefore, economic growth is the steady process of increasing the national incomes through government conscious effort of influencing economic variables through fiscal policy or monetary policy measures. From Keynesian analysis, it is emphasized that demand management policies can and should be used to improve macroeconomic performance. This is premised on the fact that private sector is inherently unstable. It is subject to frequent and quantitatively important disturbances in the components of aggregate demand. It is the task of counter cyclical or stabilization policies to offset the private sector disturbances and to keep real output close to its market equilibrium time path (Omitogun & Ayinola, 2007).

According to Divivedi (2004), economic growth is a sustained increase in per capita national output or net national product over a long period of time. It implies that the rate of increase in total output must be greater than the rate of population growth.

Per Capita Income (PCI) simply refers to the national income (that is GDP) per person in an economy (country).

According to the World Bank (2011):

“GDP per capital is gross domestic product divided by mid year population. GDP is the sum of gross value added by all resident producers in the economy plus any product taxes minus any subsidies not included in the value of the product. It is calculated without making deductions for capital consumption of fabricated assets or for depletion and degradation of natural resources”. p.70.

Available evidence from the World Bank report of (2005) and Iyola (2007) states that per capita income in Nigeria between 2005 and 2012 averaged \$26. The World Bank development report (2010) reveals that Nigeria’s per capita income stands at US \$2,748. This amount falls behind Ghana and Cameroun with US \$10,748 and US \$10,758 respectively. It concluded that countries dependent on the export of oil like Nigeria, have not only performed worse than their resource poor counterparts; they have also performed poorly than they should have given their revenue streams. Thus, the need to focus attention on tax revenue and how to improve the growth rate in Nigeria.

2.1 Theoretical Framework

Dominant theories of economics growth have suggested that significant relationship exist between national income and economic growth. Two economic growth theories that this study hub on are the Neoclassical Growth Theory (Solow- Swan Model) and the Endogenous Growth model. The Solow-swan model unlike the Harrod-Dormar model which holds that various steady-state rate of growth are all dependent on the rate of savings, the neoclassical model attribute this mostly to technological change and emphasis that government conscious effort aim at technological knowledge acquisition drives growth and that taxes do not affect the steady state growth and total factor productivity. On the other hand, Endogenous growth theory by Romer (1986) emphasize factors such as “Spill-over” effect and “learning by doing” by which firms specific decision to invest in capital and Research and Development (R&D), or individual investment in human capital can yield positive external effect that benefit the rest of the company. In this model, government spending and tax policies can have a long-run of permanent growth effect.

On the side of Taxation, Bhartia (2009) identified socio-political theory and the expediency theory of taxation. The socio-political theory states that

social and political objectives should be the major factor in selecting taxes. The theory advocated that a tax system should not be designed to serve individual but should be used to sure the ills of society as a whole. Also, the expediency theory asserts that every tax proposal must pass the test of practicality as the only factor weighting when formulating and implementing tax policies. These theories generally focus on generating optimal revenue at minimal cost, and takes into consideration tax payers' position in the imposition.

2.3 Empirical Studies

Empirically, several studies have been conducted on taxes and economic growth. The studies of Engen and Skinner (1996), Anyanwu (1997), Tosun and Abizadeh (2005) and Arnold (2011) provided different explanations of taxes effect on economic growth. Engen and Skinner (1996) in their study of taxation and economic growth of United States economy, large sample of countries and use of evidence from micro level studies of labour supply, investment demand, and productivity growth found modest effect on the order of 0.2 to 0.3 percent points. Tosun and Abizadeh (2005) in their study of economic growth as a result of tax changes in OECD countries from 1980 to 1999 reveal that economic growth measured by GDP per capita has a significant effect on the tax mix. Arnold (2011) in his study found that short tern recovery requires increase in demand while long-term growth requires increase in supply. Hence, policies for enhanced supply will generate substantial growth in the economy. Anestasiou and Dritasaki (2005) examined the relationship between economic growth rate and tax revenue using annual data from 1965 – 2002 and found a one-way causal relationship between marginal direct tax rate and the rate of economic growth, with direction from the marginal tax rate to the rate of economic growth going in the same direction. Johansson et al (2008), also found that taxes causes growth. According to their findings, corporate taxes are found to be most harmful for growth, followed by personal income tax and then consumption taxes, while recurrent taxes on immovable property appear to have the least impact. Other studies with varying results include Udoh and Ebong (2011), Chimobi and Uche (2010); Onyewa (2012); Abata, Kehinde and Balarinwa (2012); Ogbule (2010) and Sherif (2012). Some of these studies either study one component of the tax profile or fiscal policy and

economic growth; some with robust economic models while others with simply statistical tools.

3.0 METHODOLOGY AND MODEL SPECIFICATION

The study uses ex-post facto research design involving use of time series (secondary) data obtained from the Central Bank of Nigeria (CBN) and Federal Inland Revenue Service (FIRS). The study applies both descriptive and inferential statistics involving correlation and regression analysis. To ensure the regressions are not spurious, stationarity test involving Augmented Dickey-Fuller (ADF) Unit root test is applied on the time series data. To identify the presence of long-run relationships among variables, Johansson co-integration test was adopted. In order to correct the short-run disequilibrium, among variables, their short run behaviour was tied to their long-run values using the error correction mechanism. Finally, Granger causality test was used to determined the direction of causality between tax revenue and economic growth proxied by GDP.

The general form of the model is given as:

$$GDP = f(PPT, CIT, VAT, EDT, PIT, CED) \dots \dots \dots \text{eqn 1}$$

Where'

- GDP = Gross Domestic Product
- PPT = Petroleum Profit Tax
- CIT = Companies Income Tax
- VAT = Value Added Tax
- EDT = Education Tax
- PIT = Personal Income Tax
- CED = Custom and Excise Duties

The logarithm function of the relationship is stated as:

$$\ln GDP = \ln a_0 + a_1 \ln PPT + a_2 \ln CIT + a_3 \ln VAT + a_4 \ln EDT + a_5 \ln PIT + a_6 \ln CED + U_1 \dots \dots \text{eqn 2}$$

Where;

- ln = log of variables
- $a_0 - a_6$ = various parameters to be estimated
- U_1 = Stochastic error term

The "Priori" expectation is that the model parameters is expected to be positively signed (that is a_0 to $a_6 > 0$).

The direction of causality between tax revenue and economic growth is conducted using the formular that follows:

$$Y_t = \delta + \sum_{i=1} a_i Y_{t-i} + \sum_{j=1} \delta_j X_{t-j} + U_t \dots\dots\dots 3$$

$$X_t = \beta_1 X_{t-1} + \sum_{j=1} W_j Y_{t-j} + \dots\dots\dots 4$$

Where Y_t and X_t are the variables investigated for Granger causality. If any $\delta_j = 0$, then X_t granger cause Y_t .

Similarly, if any $W_j = 0$, then Y_t granger cause X_t . Thus, there is bidirectional causality, otherwise unidirectional.

4.0 RESULTS AND FINDINGS

This section discusses the result of the correlation matrix

Table 4.1: Correlation Matrix for the Variables

	GDP	EDT	CIT	CED	PIT	PPT	VAT
GDP	1.0000	0.8560	0.9461	0.4823	0.9189	0.9344	0.9710
EDT	0.8560	1.0000	0.9626	0.1839	0.9446	0.8559	0.9439
CIT	0.9461	0.9626	0.0000	0.2532	0.9822	0.9207	0.9918
CED	0.4823	0.1839	0.2532	1.0000	0.1889	0.3159	0.3216
PIT	0.9199	0.9446	0.9822	0.1889	1.0000	0.9305	0.9793
PPT	0.9344	0.8559	0.9207	0.3159	0.9305	1.0000	0.9447
VAT	0.9710	0.9439	0.9918	0.3216	0.9793	0.9447	1.0000

Source: Author's computation using Eviews 4.0 software

Table 4.1 depicts the relationships among the variables used in this study. Specifically, the relationships among some of the key variables are further highlighted. The correlation coefficient of GDP and EDT is 0.856, CIT (0.946), CED (0.486) PIT (0.919), PPT (0.93) and VAT (0.97) respectively, showing a pair-wise correlation that are quite high with all strong perfect positive relationship except for CED (.418%). EDT to CIT (0.96), CED (0.18), PIT (0.94), PPT (0.86) and VAT (0.97). The strong perfect positive relationship could be explained by the fact that this tax revenue is charged at 2% of companies assessable profit, except for CED (0.18) indicating a weak relationship. The relationship between CIT and other independent variables shows PIT (0.98), PPT (0.92) and VAT (0.98) meaning a strong positive relationship. This may be explained by the fact that most companies

chargeable to PPT also engaged on activities chargeable to CIT and VAT. CED in relation to other variables indicate weak positive relationship of EDT (0.18), CIT (0.25), PIT (0.18), PPT (0.32) and VAT (0.32) respectively. Also, PIT to PPT (0.93) and VAT (0.97) while, PPT to VAT (0.94).

Although the dependent and independent variables show positive correlation, this is in contrast to the a priori negative sign expected, and since they may exist several industrial sector which has not been very productive over the years under review.

Table 4.2. Descriptive Statistics for the Variables

S/N		GDP	PPT	CIT	VAT	EDT	PIT	CED
1.	Mean	8.0998	60.507	17.191	14.993	31.558	3.0126	76.91
			0	2	5	8		39
2.	Median	27.055	67.630	30.550	33.900	3.0500	0.4000	33.29
		8	0	0	0			00
3.	Maximum	47.119	32.013	99.840	80.270	27.940	51.600	28.41
		7	0	0	0	0	0	62
4.	Minimum	30.354	10.600	3.0000	0.0000	0.0000	0.0000	16.16
		675						00
5.	Std. Dev.	10.817	93.026	27.354	23.329	63.592	15.297	92.22
		0	1	5	2	4	4	32
6.	Skewness	1.1061	1.6792	1.7614	1.5900	2.5021	1.8857	1.028
								4
7.	Kurtosis	2.6245	4.7081	4.8596	42.436	8.8619	5.0678	2.536
					4			3
8.	Jarque - B	7.1327	20.110	22.478	16.517	84.156	26.208	6.297
			9	0	3	8	0	8
9.	probability	0.0283	0.0000	0.0000	0.0003	0.0000	0.0000	0.042
								9

10. Observations	34	34	34	34	34	34	34
------------------	----	----	----	----	----	----	----

Source: Author's Computation Using Reviews 4.0 Software

Table 4.2 shows some basis descriptive statistics of variables used in this study. It indicates that the average GDP was 8.09%, PPT (60.51%), CIT (17.19%), VAT (14.99%), EDT (31.53%), PIT (8.01%) and CED (76.91%) respectively, while the maximum and minimum values were GDP (47.62%) and (30.35%), PPT (32.01%) and (10.60%), CIT (99.84% and 3.00%), VAT (80.27% and 0.0000%) and EDT (27.94% and 0.00%), PIT (51.60% and 0.00%) and CED (28.42% and 16.16%). The standard deviations of 10.82 for GDP, PPT (92.026), CIT (27.35), VAT (23.33), EDT (63.59), PIT (15.29) and CED (92.22) shows that the period experienced wide fluctuations in all variables studied. The fluctuations in the variables under study were also confirmed by the positive Skewness values for all variables of GDP (1.10), PPT (1.68), CIT (1.76), VAT (1.59), EDT (2.50), PIT (1.89) and CED (1.02) respectively. The probability values were all statistically significant.

4.3 Analysis of Integration Properties

The result of Augmented Dickey Fuller Unit Root Test is presented below following pre-testing procedure and the regression results are shown below:

Table 4.3 Augmented Dickey Fuller Unit Root Test

Variables	ADF	Statistics		5% Critical Value		Remarks
	(Computed)	1 st Difference	Level	1 st Difference	Level	
Ln (CED)	-1.624562	-	-2.9558	-2.9591	-2.9558	1 (0)
Ln (CIT)	1.026320	-4.226309	-2.9558	-2.9591	-2.9558	1 (1)
Ln (EDT)	-0.312123	-5.651240	-2.9558	-2.9591	-2.9558	1 (1)

Ln (GDP)	0.979297	-3.371442	-2.9558	-2.9591	1 (1)
Ln (PIT)	0.870419	-3.192205	-2.9558	-2.9591	1 (1)
Ln (PPT)	0.074219	-6.284477	-2.9558	-2.9591	1 (1)
Ln (VAT)	2.227924	-3.024709	-2.9558	-2.9591	1 (1)

Source: Author's Computation Using Eview 4.0 Software

** Ln = log

The results of the integration test conducted on all the variables are presented in Table 4.3. Augmented Dickey Fuller (ADF) unit root test was applied on all the variables. The results of the unit-root test indicate that 1 out of the 6 variables were stationary at level, that is, it was integrated in the first order or 1 (0) stationary. The variable that is stationary is CED implying that the variables CIT, EDT, PIT, PPT, VAT and GDP are integrated of order one 1 (1). Therefore, a co-integration test was carried out to confirm and determine the existence of a long-run relationship among the variables in each equation. The Johansen Cointegration test procedure was adopted. Both trace test statistic criterion and maximum Eigen value criterion were used to draw the conclusion on the rank of cointegrating relationships. The decision criterion is that when the trace statistic is greater than the 5% critical value, we reject the hypothesis of no cointegrating relationship among the variables and conclude that there is cointegrating relationship among them.

The cointegration test results presented in table 4.4 was carried out in a systematic manner. Tests are run for variables constituting the regression equation to ensure that a long-run relationship exist between them before the equation is estimated.

4.4 Estimation of Regression Equation and Hypotheses Testing: In the previous section, the existence of long-run relationship among variables in the specified model was confirmed. This implies that regression can be run with the variables at levels without the fear of obtaining spurious results.

This study will be concerned with the parsimonious model that is more interpretable as shown in table 4.5. Parsimonious model for gross domestic product

Table 4.4: Unrestricted Cointegration Rank Test (Trace and Eigen) on GDP, EDT, CIT, CED, PIT, PPT, VAT

Eigen Value	Likelihood Rate (Trace Statistic)	5 Percent Critical Value	1 Percent Critical Value	Hypothesized No. of CE (s)
0.999431	572.2495	146.76	158.49	None **
0.979049	333.1496	114.90	124.75	at most 1 **
0.957725	209.4507	87.31	96.58	At most 2 **
0.816439	108.2165	62.99	70.05	At most 3 **
0.611168	53.96984	42.44	48.45	At most 4 **
0.319582	23.74242	25.32	30.45	At most 5
0.300160	11.42090	12.25	16.26	At most 6

*** (**)** denotes rejection of hypothesis at 5% (1%) significance level

L. R. Test indicates 5 cointegrating equation at 5% significance level

Source: Author's Computation using Eviews 4.0 Software

The likelihood ratio (trace statistics) indicates that at 5% level of significance, there are 5 cointegrating variables. From this, the conclusion can be drawn that a long-run relationship exists between these variables. This conclusion is robust because the unrestricted cointegration test using the maximum Eigen value confirmed the existence of five cointegrating equations. Since the existence of one cointegrating equation is enough to confirm a long-run relationship, the presence of 5 in this case establishes this. The identified cointegrating equation can then be used as an error correction term (ECM) in the error correction model. Having established the extent and form of cointegrating relationships between the variables of the model, an over parameterized error correction model was estimated. At this level, the over parameterized model is difficult to interpret in any meaningful way: its main function is to allow us to identify the main dynamic patterns in the model.

The logarithm form of the model used for the study is as stated below:

$$\ln \text{GDP} = \ln a_0 + a_1 \ln \text{PPT} + a_2 \ln \text{CIT} + a_3 \ln \text{VAT} + a_4 \ln \text{EDT} + a_5 \ln \text{PIT} + a_6 \ln \text{CED} + u_1$$

Table 4.5 Parsimonious Model for Gross Domestic Product (GDP)

Variable	Coefficient	Std-error	t-statistic	Prob.
D (LOG (PIT))	0.683842	0.970672	3.704504**	0.0015
D (LOG (PIT(-1)))	1.827925	1.459066	1.252805*	0.2569
D (LOG (PPT))	0.360590	0.472622	2.762956**	0.0004
D (LOG (VAT))	2.845995	4.045041	4.703576**	0.0001
D (LOG (EDT))	-1.550418	1.119379	-1.385070*	0.2153
D (LOG (CIT))	2.940964	4.635609	3.634429**	0.0042
D (LOG (CIT (-1)))	2.286043	3.554049	0.643222*	0.3209
D (LOG (CED))	0.511542	0.627890	1.914700*	0.0064
D (LOG (CED (-1)))	-0.236908	0.573915	-0.414700*	0.6941
ECM (-1)	-0.033045	0.022751	-2.452452**	0.0066
C	17.38039	1.421629	12.22569	0.0000

R-squared 0.732006

Adjusted R. Squared 0.727985

F-Statistic 42.82066

Durbin-Watson State 1.947024

Prob. (F.statistic) 0.00003

** = signification at 5 per cent level

* = Not significant at 5 per cent level

Dependent variable: LOG (GDP)

Source: Author's Computation using Eviews 4.0 software.

From table 4.5, the lagged value of PIT is positive for both the current and previous years and confirms to economic theoretical value. This implies that a 1 per cent increase in economic growth was brought about by 0.683842 per cent increase in PIT, ceteris paribus. Also, the coefficient of the lagged PIT is statistically significant at 5 per cent level for current year as against the previous years' figure. We therefore state that personal

income tax has significant effect on economic growth in the period under review. This is premise on the overall F-statistic of 42.82 and the probability of 0.0015 which indicates that this conclusion is robust and the result significant.

Also, the lagged value of PPT has a positive sign that is in line with economic theoretical expectation the coefficient is statistically significant at 5 percent level. The implication of this result is that a 1 percent rise in economic growth rate is accounted by a 0.360590 per cent rise in the PPT, all things being equal. We therefore, state that petroleum profit tax influenced economic growth in Nigeria. This result is further collaborated by Worlu and Nkoro (2012) that investigated tax revenue and economic development in Nigeria and concluded that growth in GDP is enhanced by taxes generated from petroleum profits.

The coefficient of Value Added Tax (VAT) is correctly signed and statistically significant at 5 per cent level. This means that an increase in economic growth is accounted by 2.845995 per cent changes in VAT, *ceteris paribus*. The coefficient is significant at 5 per cent level, hence that value added tax affect economic growth in Nigeria. The result is further collaborated by the findings of Adereti, Sanni and Adesina (2011) who studied value Added Tax and Economic Growth of Nigeria and find that VAT revenue and GDP in Nigeria are positively and significantly correlated.

The lagged value for Education Tax (EDT) is not correctly signed, and is also not statistically significant at 5 per cent level. This means that an inverse relationship exist between the dependent variable-economic growth and education tax when lagged as indicated by the negative coefficient. We therefore state that education tax does not impact significantly on economic growth in Nigeria.

In the same table, the value for Company Income Tax (CIT) and its one year lagged value are statistically significant at 5 per cent level for the current year, but statistically insignificant at 1 per cent level the previous one year. The positive sign conforms to a priori economic theory expectations but the result contradict that of Gale and Samwick (2014), that investigates effects of companies income tax changes on economic growth and observed a negative relationship. From our result, we state that there is a significant relationship between company income tax and economic growth in Nigeria. The implication of the result is that a 1 per cent rise in economic growth will brought about by 2.94 per cent increase in previous year's CIT.

Also, the value of Custom and Excise Duties (CED) and its one year lagged value are only marginally positive for the current period, but negative for the 1 year. The result is also not statistically significant at 5 per cent level. We therefore state that there is no significant relationship between custom and excise duties and economic growth in Nigeria. The implication is that CED impact negatively on the dependent variable.

On the whole, since the analysis is done based on the parsimonious result it is imperative we review the overall regression result. The strong significant of the error correction mechanism (ECM) supports our earlier argument that the variables are indeed co-integrated. The ECM shows a relatively low speed of adjustment (3 per cent) of the short-run and long-run equilibrium behavior of economic growth and the explanatory variables, indicating longer adjustment trend.

The adjusted R^2 show that about 73 per cent of the total variation in gross domestic product is determined by changes in the explanatory variables. Thus, it is a good fit. The F-statistic (42.82) indicates that all the variables are jointly statistically significantly at 5 per cent level. The Durbin- Watson statistic of 1.9 reveals that it is within the acceptable bounds, thus it is good for policy analysis. The probability (F-statistic) of 0.0000 indicates that this conclusion is robust and the result significant.

4.5 Granger Casualty Test

Table 4.6 Pairwise Granger Causality Tests

NULL Hypothesis	Obs.	F-statistic	Probability
EDT does not Granger cause GDP	33	3.56486	0.06872
GDP does not Granger Cause EDT		0.18204	0.34971
CIT does not Granger Cause GDP	33	13.6768	0.00087
GDP does not Granger Cause CIT		1.6673	0.20126
CED does not Granger Cause GDP	33	58.3709	1.6E.08
GDP does not Granger Cause CED		0.30032	0.58773
PIT does not Granger Cause GDP	33	26.8079	1.4E-05
GDP does not Granger Cause PIT		1.19549	4.24405
PPT does not Granger Cause GDP	33	9.38386	0.00459
GDP does not Granger Cause PPT		0.29221	1.82305
VAT does not Granger Cause GDP	33	14.7614	0.00059
GDP does not Granger Cause VAT		1.23958	1.33208

Source: Author's Computation using Eviews 4.0 software.

The results of the Granger Causality test in Table 4.6 indicates that the hypothesis, tax revenue does not Granger cause economic growth, and that economic growth does not Granger cause tax revenue cannot be rejected. The results for the variables EDT, CED and PPT shows that there is a unidirectional causality between economic growth and the independent variables and the direction of causality runs from the explanatory variables to economic growth. The result implies that these variables are source of economic growth. Results for the variables CIT, PIT and VAT shows converse causality indicating that CIT, PIT and VAT does not Granger cause economic growth. Going by the probability values of 0.0687, 0.0087, 1.6E-

08, 1.4E-08, 1.4e-05, 0.000459 and 0.00059 respectively, we reject null hypotheses for CIT, PPT and VAT and accept the null hypotheses for EDT, CED, and PIT.

5.0 SUMMARY, CONCLUSION AND RECOMMENDATION

The objective of this study is to investigate the relationship between tax revenue and economic growth in Nigeria from 1980 to 2013 using correlation and regression analysis. Some economic growth theories and taxation theories were reviewed in line with the objective of the study as well as empirical literature.

The model for estimation was derived from the Endogenous growth theory which was modified in line with our study. The estimation of the model was based on ordinary least squares in the context of error correction mechanism from the linear regression results using ordinary least square (OLS) method, the following can be deduced:

- i. The GDP has the lowest average (mean) value as against other variables studied as well as standard deviation (see table 4.1).
- ii. The correlation coefficient between GDP and all other variables were relatively high except for CED.
- iii. The Augmented Dickey-Filler unit root test shows five variables integrated at order one I (1). There are CIT, EDT, PIT, PPT, VAT and GDP, while CED was stationary at level.
- iv. The over parameterized error correction model identified the main dynamic patterns in the model, helping us to run this parsimonious model.
- v. The parsimonious results, the lagged values for PIT, PPT, VAT, and CDT were statistically significant at 5 per cent level for both the current and previous years. But EDT, and CED were not statistically significant at the 5 percent level.
- vi. Finally, it was also noted that CIT, PIT and VAT does not Granger cause economic growth, while EDT, CED and PPT shows unidirectional causality between economic growth and the independent variables and the direction of causality runs from the explanatory variables to economic growth.

Relying on the findings of this study, the following recommendations are made:

1. There is a need for tax system restructuring that will not distort economic growth and also cause quick restoration of the equilibrium if distortions exist. Hence, the need to reform consumption and residential property taxes.
2. Policymakers in considering a tax structure or system should have to weigh up the different goals that the system seeks to achieve and balance efficiency and growth-oriented objectives.
3. Policy options that create as few obstacles as possible to investment, innovation, entrepreneurship and other drivers of economic growth should form the focus of taxation policies in the country.
4. The present concession and waiver regime to importers should be reviewed for reasonableness and necessity.

REFERENCES

- Abata, M. A., Kehinde, J. S. and Bolarinwa, S. A. (2012) "Fiscal/Monetary Policy and Economic Growth in Nigeria: A Theoretical Exploration, *International Journal of Academic Research in Economics and Management Sciences* Vol. 1(5): 75-88.
- Abiola, J. and Asiwah, M. (2012). "Impact of Tax administration on Government Revenue in a Developing Economy – Case Study of Nigeria". *International Journal of Business and Social Science*, Vol. 3 (8): 311 – 328.
- Adegbe, F. F. and Fakile, A. S. (2011). Company Income Tax and Nigeria Economic Development, *European Journal of Social Sciences*, Vol. 22 (2): 309 – 322.
- Aguolu, O. (2010), "Tax Reform in Nigeria: Unrealized Expectations". *Bulletin for International Taxation*, Vol. 64 (1): 61 – 67.
- Ahmad, E. and Stern, N. (2011), *Theory and Practice of tax Reform in Developing Countries*, Cambridge: Cambridge University Press.
- Akintoye, I. R. and Tashie, G. A. (2013). "The Effect of Tax Compliance on Economic Growth and Development in Nigeria, West-Africa, *British Journal of Arts and Social Sciences*. Vol. 11(11): 222-231.
- Anastassiou, T. and Dritsaki (2005). Tax Revenues and Economic Growth. An Empirical Investigation for Greece using Casuality Analysis. *Journal of Social Sciences*, 1 (2) pp. 99-104.
- Anyanwu, J. C. (1997). *Nigerian Public Finance*. Joanne Educational Publishers, Onitsha
- Ariyo, A. (1997). "Productivity of the Nigerian Tax System; 1970 – 1990". AERC Resources Paper 67. Nairobi: *African Economic Research Consortium*.

- Arnold, J. M. (2011). Tax Policy for Economic Recovery and Growth. *Economic Journal*. 12(550), pp. 59-80
- Aruwa, S. A. (2010). "Public Finances and Economic Growth in Nigeria – Fiscal Policy Implications in Crises Era, *Journal of Public Finance* vol. 19(1): 9-22.
- Bhartia, H. L. (2009). *Public Finance*, 14th Edn. Vikas Publishing House PVT Ltd, Nel Delhi, India.
- Chimobi, O. P. and Uche, U. C. (2010). "Taxation and Economic Output in Nigeria. A Causality Test for Nigeria, *American Journal of Scientific Research* Vol. 8: 78-87.
- Dwivedi, D. N. (2004). *Managerial Economics 6th Ed*. New Delhi, India; Vikas Publishing House PVT Ltd.
- Enge, E. and Skinner, J. (1996). "Taxation and Economic Growth", *National Tax Journal*, 49 (4) pp. 617-642.
- Fadare, S. O. (2010). Recent Banking Sector Reforms and Economic Growth in Nigeria. *Middle Eastern Finance and Economics*, Vol. 8: 1450 – 2889.
- Federal Inland Revenue Service (FIRS) (2012). *Taxation Reforms in Democratic Nigeria*, Ibadan, Nigeria, Safari Books Ltd.
- Federal Republic of Nigeria (FRN) (2004) "*Personal Income Tax Act Amendment LFN CAP P8, Official Gazette*", Abuja: Federal Ministry of Finance.
- International Monetary Fund (2011) Working Paper Series, WP/00/65. *Tax Policy for Emerging Markets - Developing Countries*.
- International Tax Compact (ITC) (2010), "Addressing tax Evasion and tax Avoidance in Developing Countries. Economic Development Issues: 14-42.

- Iyoha, M. A. (2007). Government Spending in Nigeria. *Nigerian Journal of Social and Economic Studies*. Vol. 11 (3): 386 – 396.
- Jhingan, M. L. (2004). *Money, Banking, International Trade and Public Finance*. Vrinda Publications, New Delhi.
- Johansson, A., Heady, C., Arnold, J., Brys, B., AND Vartia, L. (2008) *Tax and Economic Growth* (No. 620). Working Paper, OECD Economic Department. OECD Publishing.
- Kayaga, L. (2007). Tax Policy Challenges Facing Developing Countries: A Study of Uganda, IMF WPS 204.
- Khosravi, A. and Karimi, M. S. (2010). To Investigate the Relationship between Monetary Policy, Fiscal Policy and Economic Growth in Iran: Autoregressive Distributed Lag Approach to Co-Integration. *American Journal of Applied Sciences*, Vol. 7 (3): 420 – 424.
- Kiabel, D. B. and Nwokah, G. N. (2009) "Boosting Revenue Generation by State Governments in Nigeria: The Tax Consultant Option Revisited." *European Journal of Sciences*. Vol. 8 (4): 217 – 240.
- Musgrave, R. A. and Musgrave, P. B. (2004). *Public Finance in theory and Practice*, Tafa, McGraw Hill, New Delhi, India.
- National Tax Policy (2010) NTP – FGN. "*Finance Policies and Producers*" FIRS, September, 2010.
- Nenbee, S. G. and Madume, J. V. (2011). The Impact of Monetary Policy on Nigeria's Macroeconomic Stability (1970 – 2009). *International Journal of Economic Development and Investment*. Vol. 2 (2): 174 – 183.
- Oduola, A. (2006). Tax Policy Reforms in Nigeria. *World Institute for Development Economic Research, Research Paper No. 2006/03*: 1 – 43.
- OECD (2013). *Taxing Profits in a Global Economy: Domestic and International Issues*, Paris, WPS 73.

- Offiong, U. B. (2013). *Personal Income Tax in Nigeria*, Lagos. CIBN Press Ltd.
- Ogbole, F. O. (2010). Fiscal Policy and Macroeconomic Performance in Nigeria. *Journal of Economics and International Finance* Vol. 3(6): 407-417.
- Ogbonna, G. N. and EbimoBowe, A. (2012). Petroleum Income and Nigerian Economy: Empirical Evidence: *Arabian Journal of Business and Management Review* (OMAN Chapter) Vol. 1 (9): 33 – 59.
- Okafor, R. G. (2012) Tax Revenue Generation and Nigerian Economic Development. *European Journal of Business and Management*. Vol. 4 (19): 49-57.
- Omitogen, O. and Ayinola, T. A. (2007). Fiscal Policy and Nigerian Economic Growth. *Journal of Research in National Development*, Vol. 5 (2): 181 – 233.
- Onyeiwu, C. (2012) Fiscal Policy and Economic Growth in Nigeria: *Journal of Economics and Sustainable development*. Vol. 3(7): 62-70.
- Osiegbu, P. I, Onuorah, A. C. and Nnamdi, I. (2010) *Public Finance: Theories and Practices*. C. M. Global Com Ltd; Asabi.
- Popoola, N. (2009) "A Good Tax System Enhance Economic Development" Available from: <http://www.pimchng.com/Article.aspx?> Accessed 22/10/2014.
- Rao, M. G. (2005). "Tax System Reform in India: Achievements and Challenges Ahead" *National Institute of Public Finance and Policy*, New Delhi 110067:1-39.
- Romer, P. M. (1986). Increasing Returns and Long-run Growth. *Journal of Political Economy*, 94(5), pp. 1002-1039

- Sheriff, M. M. (2012). Tax Reform in the Context of new Revenue Authority Administration for Liberia. *Taxation (Law, Administration and Practice)*, Vol. 8 (3): 211 – 232.
- Tosun, M. S. and Abizadeh, S. (2005). Economic Growth and Tax Components: An Analysis of Tax Change in OECD. *Applied Economics Journal*: 37 pp. 2251-2263.
- Udoh, E. and Ebong, F. (2011). Global Economic Crisis and Nigeria's Economic Recovery: A Role for Taxation. *European Journal of Humanities and Social Sciences*, Vol. 4 (2): 114 – 134.
- Unegbu, A. O. and Ireferin, D. (2011). "Impact of VAT on Economic Development of Emerging nations". *Journal of Economics and International Finance* Vol. 3(8): 492-503.
- United Nations (2005). "Resource Mobilization for Economic Development: The Role of Tax Administrator", United Nation Study in Conjunction with Association de Plantification Fiscale Financiere.
- World Bank (2011). *'Review of the Flow of Funds in the Nigerian Petroleum Sector'*, Washington, DC: WP/2011/70.
- World Bank Report (2005). *'Taxation and State Participation in Nigeria's Oil and Gas Sector'*, Washington, DC: The World Bank Group.
- Worlu, C. N. and Nkoro, E. (2012). "Tax Revenue and Economic Development in Nigeria: A Macroeconometric Approach" *Academic Journal of Interdisciplinary Studies* Vol. 1(2): 211-223.

APPENDIX

YEAR	GDP	PPT	CIT	VAT	EDT	PIT	CED	ECM
1980	49632.32	51.84	3.15	0	0	0	2241	0
1981	47619.66	63.26	4.03	0	0	0	2326	0
1982	49069.28	48.47	5.50	0	0	0	2336	0
1983	53107.38	37.47	5.62	0	0	0	1984	-3.74092
1984	59622.53	47.62	7.87	0	0	0	1616	-3.74092
1985	67908.55	67.11	10.04	0	0	0	2184	-3.74092
1986	69146.99	48.11	11.01	0	0	0	1728	-3.74092
1987	105222.8	125.04	122.35	0	0	0	3541	-3.74092
1988	139085.3	68.15	15.51	0	0	0	5672	-3.74092
1989	216797.5	10.60	19.14	0	0	0	5816	-3.74092
1990	267550	26.9	3	0	0	0	8641	-3.74092
1991	312139.7	38.6	3.8	0	0	0	11457	-3.74092
1992	532613.8	51.5	5.4	0	0	0	16055	-3.74092
1993	683869.8	59.2	9.6	0	0	0	015485	-3.74092
1994	899863.2	42.8	12.3	7.3	0	0	18295	3.559079
1995	1933212	42.9	21.9	20.8	0	0.23	37364	5.65354
1996	2702719	47.5	23.1	32.5	3.3	0.3	55000	-2.81258
1997	2801973	64.3	27.8	35.3	2.9	0.5	63000	-13.4004
1998	2708431	24.6	33.3	37.6	3.2	0.7	57700	-8.11112
1999	3194015	71.1	46.2	47.8	5.7	1.1	87900	3.946125
2000	4582127	334.5	53.3	58	8.3	1.2	101500	-0.2791
2001	4725086	407.1	69.4	91.7	16.2	2.2	170600	19.78037
2002	6912381	224.4	89.1	108.6	10.1	1.7	181400	-10.2361
2003	8487032	438	114.8	136.4	9.7	4.2	195500	-0.12221

2004	11411067	878.6	130.8	163.3	17.1	5.0	217200	0.164168
2005	14572239	1352.2	170.2	192.7	21.8	4.9	232800	-1.57673
2006	18564595	1349.5	246.7	232.7	28.4	5.9	177700	8.009225
2007	20657318	1132	332.4	312.6	59.6	10.3	241400	40.85898
2008	24296329	2060.9	420.6	401.7	59.5	27.0	271320	23.00271
2009	24712670	939.4	600.6	481.4	139.5	29.9	284162	-8.94824
2010	29205783	1480.4	666.1	564.9	89.2	32.9	30413	-3.86834
2011	29894567	3070.6	715.4	659.2	130.7	43.9	32164	8.888319
2012	30354675	3201.3	846.6	710.6	188.4	51.6	34432	-41.7406
2013	30124621	2666.4	998.4	802.7	279.4	48.9	44143	18.383

GDP = GROSS DOMESTIC PRODUCT

PPT = PETROLEUM PROFIT TAX

PIT = PERSONAL INCOME TAX

CED = CUSTOMS AND EXCISE DUTY

CIT = COMPANY INCOME TAX

EDT = EDUCATION TAX

VAT = VALUE ADDED TAX

EFFECT OF VALUE ADDED TAX AND EXCISE DUTIES ON ECONOMIC GROWTH IN NIGERIA

BY

FASINA H. Taiwo,

**DEPARTMENT OF MANAGEMENT AND ACCOUNTING, LADOKE
AKINTOLA**

UNIVERSITY OF TECHNOLOGY, OGBOMOSO.

P.M.B. 4000, OGBOMOSO. OYO STATE, NIGERIA.

taiwofash4real2@gmail.com

AND

ADEGBITE Tajudeen Adejare

**DEPARTMENT OF MANAGEMENT AND ACCOUNTING, LADOKE
AKINTOLA**

UNIVERSITY OF TECHNOLOGY, OGBOMOSO.

P.M.B. 4000, OGBOMOSO. OYO STATE, NIGERIA.

adetajud@yahoo.com

ABSTRACT

The study empirically analyses the impact of VAT and excise duties on economic growth in Nigeria. Secondary data were obtained from central bank of Nigeria statistical bulletin covering the period of 1990 to 2012. Multiple regressions were employed to analyze the data. The result showed that value added tax, excise duties, exchange rate, inflation rate and interest rate were all found to have significant effects on the Gross Domestic Product (GDP) which was proxied for Economic Growth with the Adjusted R² of 93.6%.

The study concluded that value added tax has positive significant impact on economic growth in Nigeria while excise duties has negative significant impact on economic growth in Nigeria.

It is recommended that Government should reduce the VAT rate in Nigeria as the current rate has made goods and services very expensive and invariably contributing to the noncompliance of taxpayers. A rise in the VAT rate will have a bad effect on aggregate consumption and will weaken economic growth but a reduction in the VAT rate strengthens economic growth by stimulating aggregate consumption

Key words; *Value added tax (VAT); Excise duty; Interest rate; Exchange rate; GDP;*

INTRODUCTION

Background to the study

The provision of economic and social services such as electricity, roads, telecommunications, education, health services, water supply and recreational facilities cannot be solely implemented and provided by individual without the government support. Government needs funds to carry out the implementation of these social and economic services in the country. These funds must be sourced from many sectors of the economy. One of the main sources of the governments' revenue is tax usually collected in different ways. One of these taxes is Value-Added Tax (VAT). Value added tax replaced the sales tax which had been in existence since 1986. Value added tax was introduced in Nigeria on 1st December, 1993 and its effective take off date however, was 1st January, 1994. The value added tax presently in Nigeria is at a flat rate of 5% levied on all vatable goods and services. Value added tax is a consumption tax levied on the increase in the value of goods and services in the course of their production or supply. The incidence of value added tax is on the final consumer of the goods or services. The VAT has become a key source of government revenue in over 120 countries. About 4 billion people, 70 percent of the world's population, now live in countries with a VAT, and it raises about \$18 trillion in tax revenue roughly one-quarter of all government revenue. Much of the spread of the VAT, moreover, has taken place over the last ten years. From having been largely the preserve of more developed countries in Europe and Latin America, it has become a pivotal component of the tax systems of both developing and transition economies (Ebrill et al., 2001).

Value added tax replaced sales tax due to the fact that sales tax had a very narrow base as it covered only nine categories of goods, and it negated the basic principle of consumption tax, which should cut across all consumable goods and services. In addition, sales tax concentrated only on locally manufactured goods thus placing these locally manufactured goods at a disadvantage in relation to foreign imported goods. The value added tax on the other hand covers both locally manufactured goods as well as foreign goods. The value added tax is based on the general consumption pattern of the populace. Thus, it is expected to yield huge revenue to the government. The revenue gains from VAT are likely to be higher in an economy with

higher level of per capita income, lower share of agriculture, and higher level of literacy (Ebrill et al. 2001). The current system of administering excise tax consists of flaw and imperfection due to lack of transparency. Tuan (2013) proclaimed that VAT generates only distortion on the consumption side, whereas tariff (excise duty) encourages distortion on both production and consumption sides. According to Tuan (2013), VAT is also more advantageous than tariff in terms of revenue potential: the VAT is effectively equivalent to the tax regime, where tariff is combined with tariff-equivalent excise tax on domestic production. The sign of the revenue impact is generally ambiguous, but most countries that have adopted a VAT seem to have gained a more effective tax instrument (Keen and Lockwood, 2007). In line with the views of above researchers, the effects of value added tax and excise duty on economic growth and revenue profile in Nigeria is imperative to be empirically investigated.

LITERATURE REVIEW

Overview of VAT in Nigeria

Okezie (2003) defines Value added tax (VAT) as a tax introduced in Nigeria in 1993. It is imposed on goods and services at the rate of 5%. The main aim of this tax is to raise revenue for government and its incidence is borne by the final consumer. VAT is collectible from both imported and locally manufactured goods and services. Soyode and Kajola (2006) defined VAT as a consumption tax, charged at 5% on all vatiable goods and services. According to Soyode and Kajola (2006) the attributes of VAT are:

- VAT is a consumption tax;
- VAT is a multi-stage tax, and
- The incidence of VAT is on the final consumer.

The following goods and Services according to Offiong (2004) are exempted from VAT' in Nigeria

- ❖ Medical and pharmaceutical product;
- ❖ Basic food items;
- ❖ Books and educational materials;
- ❖ Baby products;
- ❖ Commercial vehicles and their spare parts;
- ❖ Agricultural equipment and products and veterinary medicine;
- ❖ Fertilizers, farming machinery and farming transportation equipment;
- ❖ All exports of goods and services;
- ❖ Plant and machinery used in export processing zone;

- ❖ Plant, machinery and equipment purchased for utilization of gas in downstream petroleum operations;
- ❖ Tractors, ploughs, agricultural equipment and implements purchased for agricultural purposes.
- ❖ Services of community banks and primary mortgage institutions;
- ❖ Plays and performances conducted by educational Institutions as part of learning;
- ❖ Services related to education and medical services.

According Soyode and Kajola (2006) as cited in Unegbu and Irefin (2010), section 7 (2) of the Act states that VAT shall be administered and managed by the Federal Inland Revenue Service (FIRS) but shared by the three tiers of government in Nigeria from 1999 to date as follows; Federal Government: 15%, State Government: 50% and Local Government: 35%

Structures of Excise tax in Nigeria

According to Micheal (2013), excise tax is tax levied on the manufacture, sale or consumption of a single good or service or on a relatively narrow range of goods or services". In Nigeria, excise is levied on alcohol and tobacco only at a rate of 20% is charged across all excisable products in Nigeria. Excise duties are not levied on imported goods. According to Micheal (2013), these taxes should exhibit the following three key design principles:

➤ Equity

Equity refers to non-discrimination between competing and substitutable products that is alcohol content regardless of production origins and price. As it is the alcohol content that gives rise to why a particular beverage is being taxed, equity dictates that regardless of the type of alcoholic beverage, products with similar alcohol content should pay the same amount of tax.

➤ Efficiency

A good tax system provides efficient and predictable outcomes for government. According to Micheal (2013), a good excise tax must be able to achieve the following

- Positive revenue streams
- Minimises non-tax paid activity, and Minimum administrative burden in achieving revenue and controlling illicit market activity

➤ Simplicity

Taxes should be simple to administer and have minimum compliance/monitoring burdens on government, business and consumers.

Relative costs of administering revenue stream is minimized, simple to monitor its compliance, transparency and predictability, minimum number of tax bases and tax tiers.

Empirical Review of Value Added Tax

Ahmad and Mehrnoosh (2011) studied Value Added Tax & Export with the Case of Selected Countries around the World, Comparing the export before and after applying VAT in each countries implementing VAT, using the mean difference test. The results show that it has positive effects on some countries and negative effects on the others. However, comparing the average export of the countries applying VAT with other countries it can be said that the effects of VAT on export is positive.

Owolabi and Okwu (2011) empirically evaluated the contribution of VAT to the development of Lagos State economy. Development aspects considered included infrastructural development, environmental management, education sector development, youth and social development, agricultural sector development, health sector development and transportation sector development. VAT revenue contributed positively to the development of the respective sectors.

Usman and Adegbite (2013) studied the impact of value added tax on economic growth in Nigeria, regression analysis technique was used to measure the effects of independent variables on economic growth, it was concluded that value added tax had positive significant impact on economic growth in Nigeria from 1994 to 2010.

Onaolapo and Fasina (2013) evaluated the effect of VAT on the revenue profiles of state governments in south western Nigeria. Panel regression and Hausman test based on difference in fixed and random effect estimators was used. It was concluded that VAT is positive and significantly related to revenue profile of state governments in south western Nigeria.

Denis (2010) investigated the relationship between VAT and GDP in Nigerian economy. The VAT revenue and GDP from 1994 to 2008 obtained from Central Bank of Nigeria's statistical bulletin, 2008 were collected and used. GDP and VAT figures for the period of study are tested for correlation. The test revealed a strong Pearson's Product Moment Correlation (PPMC) at about 96 per cent strength. The test of significance confirmed that VAT revenue is significantly different at 99 percent confidence level in relation to GDP. This implies that VAT is not effective as revenue earner, in the sense

that significant parts of GDP which represent aggregate national income as well as aggregate national expenditure are not collected as tax.

Angus and David (2010) examined the impact of value added tax (VAT) on economic and human developments of emerging Nations from 2001 to 2009; Adamawa State of Nigeria was a case study. Data were collected from both primary and secondary sources. Regression, discriminant analysis and ANOVA were used in testing the hypotheses. It was found that VAT allocations alone accounts for 91.2% of the variations in expenditure pattern of Adamawa State, and that VAT allocations to the State within the said periods were very significant. In their conclusion, VAT had a significant impact on economic and human development of the State from 2001 to 2009.

RESEARCH METHODOLOGY

Method of Data Collection

Secondary data was used in this study. The relevant data for the study were obtained from Central Bank of Nigeria (CBN) Statistical Bulletins (various issues), National Bureau of Statistics. The data covered the period from 1990-2012.

Method of data Analysis

Regression analysis technique was used to measure the relationship between a dependent variable and independent variables.

Model Specification

Model 1

This Model evaluated the impact of value added tax and excise duty on economic growth in Nigeria. Economic growth (proxied by GDP) is the dependent variable while value added tax, excise duty, interest rate, exchange rate and inflation are independent variables.

$$GDP = \alpha_0 + \alpha_1 VAT + \alpha_2 EXCISE + \alpha_3 INTR + \alpha_4 EXCH + \alpha_5 INFL + \mu$$

$$LOGGDP = \alpha_0 + \alpha_1 LOGVAT + \alpha_2 LOGEXCISE + \alpha_3 LOGINTR + \alpha_4 LOGEXCH + \alpha_5 LOGINFL + \mu \quad 1$$

Model 2

This model also examined the impact of value added tax and excise duty on revenue profile in Nigeria. Revenue profile is a dependent variable where value added tax, excise duty, interest rate, exchange rate and inflation are independent variables.

$$TOTAREV = \alpha_0 + \alpha_1 VAT + \alpha_2 EXCISE + \alpha_3 INTR + \alpha_4 EXCH + \alpha_5 INFL + \mu$$

$$TOTAREV = \alpha_0 + \alpha_1 LOGVAT + \alpha_2 LOGEXCISE + \alpha_3 LOGINTR + \alpha_4 LOGEXCH + \alpha_5 LOGINFL + \mu \quad 2$$

Where:

- LOGGDP** - Log of Gross Domestic Product
- LOGEXCISE** - Log of Excise duty
- LOGINTR** - Log of Interest rate
- LOGVAT** - Log of Value Added Tax
- LOGINFL** - Log of Inflation rate
- LOGEXCH** - Log of exchange rate
- LOGTOTAREV** - Total Revenue Profile

PRESENTATION AND ANALYSIS OF DATA

The Effect of Value Added Tax and Excise duty on Economic Growth in Nigeria

The analysis of the effects of Value Added Tax and Excise duty on economic growth in Nigeria from the period 1990 to 2012 are stated below

Table 1 – The Effect of Value Added Tax and Excise duty on Economic Growth

Dependent variable	Independent variables	Coefficient	Standard error	T	P>/t/	95%Conf. Internal)	
LOGGDP	LOGVAT	1.296417	.1746593	7.42	0.000	.9190886	1.673745
	LOGEXCISE	-1.111069	.2153349	-5.16	0.000	-1.576272	-.6458664
	LOGINTR	-.5446694	.4522167	-1.20	0.250	-1.521624	.4322854
	LOGEXCH	.4627667	.1125166	4.11	0.001	.2196893	.7058441
	LOGINFL	-.023276	.081876	-0.28	0.781	-.2001584	.1536065
	CONSTANT	13.57589	1.452515	9.35	0.000	10.43792	16.71386
R-squared = 0.9470	Adj R-squared = 0.9362			Prob > F = 0.0000	F(5, 13) = 110.55		
					Root MSE = .20333		

Source : Regression using STATA 11

The above table is represented by regression plots below:

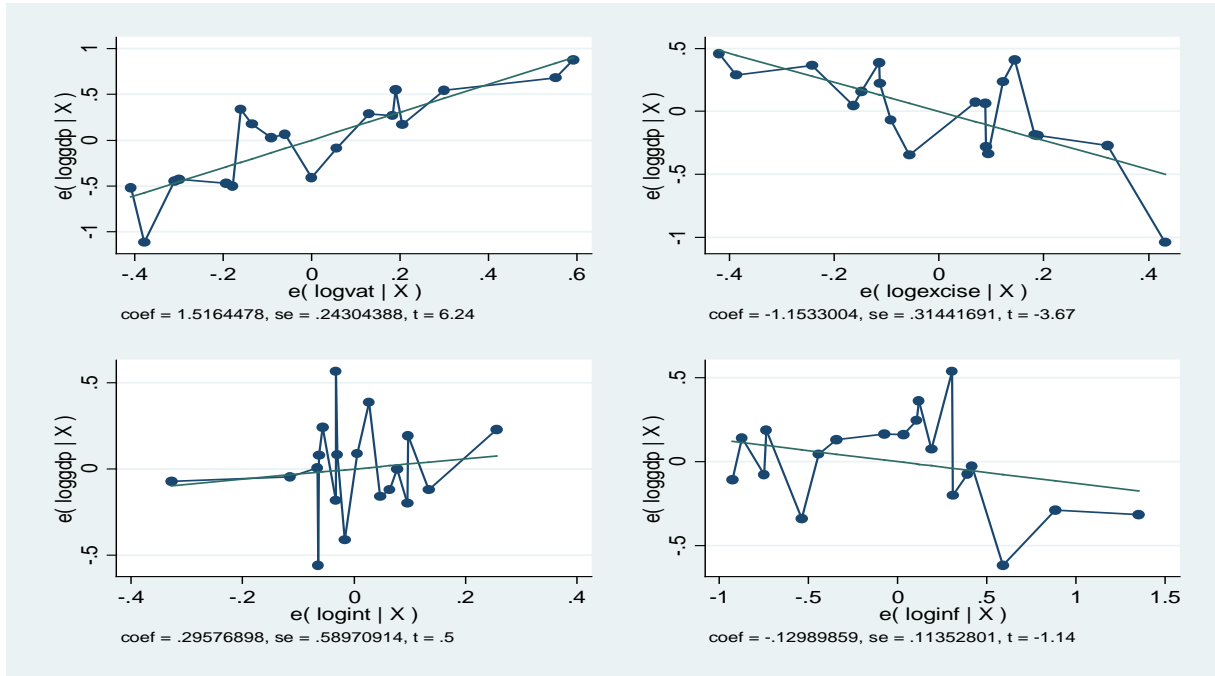

Table 1 above shows the effect of value added tax and excise duty on economic growth in Nigeria. 1% increase in VAT increases GDP by 1.29%; this shows that there is a positive relationship between VAT and GDP. The result is significant, as VAT increases GDP also increases. Also, 1% increase in EXCISE reduces GDP by 1.11%; this shows that there is a negative relationship between EXCISE and GDP, as EXCISE increases GDP reduces. Also, 1% increase in interest rate (INTR) reduces GDP by 0.54%; this shows that there is also a negative relationship between INTR and GDP. As INTR increases GDP also reduces. On the contrary, 1% increase in exchange rate (EXCH) increases GDP by 0.46%; this shows that there is also a positive relationship between EXCH and GDP. As EXCH increases, GDP also increases. Lastly, 1% increase in INFL reduces GDP by 0.23%; this shows that there is a negative relationship between INFL and GDP. As INFL increases GDP also reduces.

Given the R^2 which is the coefficient of determination as 0.9470(Approximated 95%) with high value of Adj. R^2 which is 93.6%.It connotes that independent variables incorporated into this model were able to determine the effect of VAT and EXCISE on GDP to the tune of 97%, significantly confirmed by probability of F which is 0.0000

The Effect of Value Added Tax and Excise duty on Total revenue in Nigeria

The analysis of the effects of Value Added Tax and Excise duty on revenue profile in Nigeria from the period of 1990 to 2012 are stated below

Table2 – The Effect of Value Added Tax and Excise duty on Total revenue in Nigeria

Dependent Variable	Independent Variables	Coefficient	Standard error	T	P>/t/	95%Conf. Internal)	
LOGTOTAREV	LOGVAT	.7047481	.2192239	3.21	0.007	.2311437	1.178353
	LOGEXCISE	-.5587573	.270278	-2.07	0.059	-1.142657	.0251428
	LOGINTR	-1.583399	.5676006	-2.79	0.015	-2.809625	.4322854
	LOGEXCH	.9402234	.1412255	6.66	0.000	.6351243	1.245322
	LOGINFL	-.001058	.1027669	-0.01	0.992	-.2230723	.2209564
	CONSTANT	13.49644	1.823127	7.40	0.000	9.55781	17.43506
R-squared = 0.9687	Adj R-squared = 0.9567	Prob > F = 0.0000		F(5, 13) = 80.59			
				Root MSE = .25521			

Source : Regression using STATA 11

The above table is represented by regression plots below:

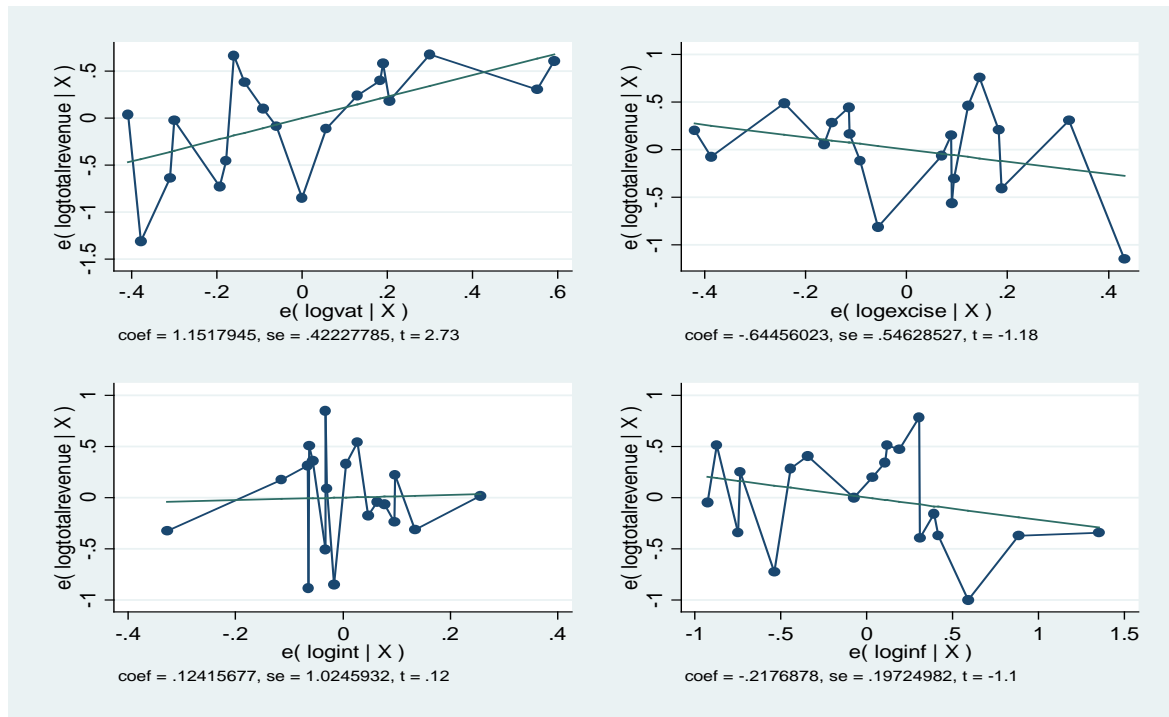

Table 2 above shows the effect of value added tax and excise duty on revenue profile in Nigeria. 1% increase in VAT increases revenue profile

(TOTAREV) by 0.7%; this shows that there is a positive relationship between VAT and TOTAREV. As VAT increases TOTAREV also increases. Also, 1% increase in EXCISE reduces TOTAREV by 0.56%; this shows that there is a negative relationship between EXCISE and TOTAREV, as EXCISE increases TOTAREV reduces. More so, 1% increase in interest rate (INTR) reduces TOTAREV by 1.58%; this shows that there is also a negative relationship between INTR and TOTAREV. As INTR increases TOTAREV also reduces. Conversely, 1% increase in exchange rate (EXCH) increases TOTAREV by 0.94%; this shows that there is also a positive relationship between EXCH and TOTAREV. As EXCH increases TOTAREV increases. Lastly, 1% increase in INFL reduces TOTAREV by 0.01%; this shows that there is a negative relationship between INFL and TOTAREV. As INFL increases TOTAREV also reduces.

Given the R^2 which is the coefficient of determination as 0.9687 (Approximated 97%) with high value of Adj. R^2 which is 95.6% (Approximated 96%). It signifies that independent variables incorporated into this model were able to determine the effect of VAT and EXCISE on revenue profile (TOTAREV) to the tune of 96%, confirmed significantly by probability of F which is 0.0000.

SUMMARY AND CONCLUSIONS

This study examined the effects of value added tax and excise duty on economic growth; it also determined the impact of value added tax and excise duty on revenue profile in Nigeria. The result of the study showed that there is a positive significant impact of value added tax on economic growth in Nigeria as supported by Usman and Adegbite (2013), Owolabi and Okwu (2011) and Charlotte (1973) but excise duty has negative impact on economic growth. In addition, value added tax improved revenue in Nigeria significantly. The study also reviewed that there is a positive significant impact of exchange rate on economic growth and revenue profile in Nigeria.

It is recommended that Government should reduce the VAT rate in Nigeria as the current rate has made goods and services very expensive and invariably contributing to the noncompliance of taxpayers. A rise in the VAT rate will have a bad effect on aggregate consumption and will weaken economic growth but a reduction in the VAT rate strengthens economic growth by stimulating aggregate consumption.

REFERENCES

Ahmad J. S. Mehrnoosh A. and Abedini M. (2012), Value Added Tax & Export: Evidence from Panel Data Regression. Middle-East Journal of Scientific Research 11 (2): 253-259, 2012

Ahmad J. S. and Mehrnoosh (2011). A Value Added Tax & Export: the Case of Selected Countries around the World. Journal of Economics and Behavioral Studies Vol. 2, No. 6, pp. 298-305, June 2011

Charlotte E.R. (1973). A value added tax and factors affecting its economic impact. Federal Reserve Bank of St. Louis. Page 15 – 19

Denis B. (2010): Investigating the Relationship between VAT and GDP in Nigerian Economy. Journal of Management and Corporate Governance, Volume 2, December 2010, pp 65-72

Ebrill et al. (2001): *The Modern VAT*. Washington D.C.: IMF.

Micheal O. (2013): Import tariff and excise duty, Nigeria experience. African Tax forum

Okezie AS (2003): Personal Income Tax in Nigeria (Principles & Practice) ASO Publications Aba, Nigeria.

Onaolapo, A.A. and Fasina, H.T. (2013): An investigation of the effect of VAT on Revenue Profiles of South Western Nigeria. European Journal of Business and Management Vol 5, No 23, pp110-115.

Offiong U.B (2004): Foundations of Companies & Petroleum Taxation in Nigeria FOB Publications Lagos, Nigeria

Owolabi S.A and Okwu, A. T (2011): Empirical Evaluation of Contribution of Value Added Tax to Development of Lagos State Economy. Vol. 5, No. 4, pp. 12-2.

Soyode L, Kajola SO (2006). Taxation – Principles and Practice in Nigeria Silicon Publishing Company Ibadan, Nigeria

Tuan M. L. (2013). Value Added Taxation: Mechanism, Design, and Policy Issues. Paper

prepared for the World Bank course on Practical Issues of Tax Policy in Developing Countries.

Unegbu A. O. and Irefin D.(2010). Impact of VAT on economic development of emerging

Nations. *Journal of Economics and International Finance* Vol. 3(8), pp. 492-503, August 2011

Usman O. A. and Adegbite T.A. (2013). Value added tax and economic growth: The Nigeria

experience (1994 -2010). *International Journal of Research in Commerce, IT & Management*. Volume NO. 3 ,issue No. 03, pp 86-90 (March)

TAX MANAGEMENT AND ECONOMIC GROWTH OF NIGERIA – Lawal, I
Department of Accounting and Finance,
Faculty of Management Sciences,
Abubakar Tafawa Balewa University
Bauchi.
Speak2idris@gmail.com
(+2348038596655)

ABSTRACT

The study is a theoretical research that assesses the bi-directional two-way relationship between tax management and the economic growth in Nigeria. Many theories and views expressed by many authors and management scholar were reviewed in search of a theoretical framework as well as proof of concept for the study. The main objective of the study is to examine the impact of tax management on the economic growth of Nigeria as a country in terms of poverty alleviation and provision of amenities. The results revealed that tax management has a significant impact on the economic growth of the country. However, there is over dependence on oil as source of revenue to the country which has resulted into poor management of the country's tax system. This has in turn led to a slow rate of economic growth and high rate of poverty among the populace. The study recommends a redefinition of tax management and strengthening of the internal mechanisms for economic growth and development. Tax management efforts should be improved upon to check the menace of tax evasion and improve the amount of revenue generated through tax.

Keywords: Tax Management, Economy Growth, Tax Evasion, Tax Avoidance, Tax Delinquency.

Word count: 185

INTRODUCTION

The Economic growth of any state depends largely on how the taxes collected by its government are properly managed to provide amenities and infrastructure necessary for economic activities to thrive (Ogbonna & Appah, 2012). Every government is charged with the responsibility of providing its populace with the basic infrastructure and amenities needed for survival and economic development. These amenities include electricity, pipe-born water, hospitals, schools, access roads as well as a rise in per capital income and poverty alleviation among others. The government therefore imposes tax on individuals and organizations in order to generate revenue to meet this obligation. A tax is a compulsory contribution to the public authority to cover the cost of services rendered by state for the general benefit of its people. According to Alabede (2001), "Tax can be defined as a compulsory levy imposed by government on individuals and organizations within a country primarily for the purpose of raising revenue to execute its expenditure programmes". It can be seen clearly from this definition that tax is a powerful instrument used by the government of any state in raising revenue to finance economic activities and provide infrastructure for the citizenry.

According to Illersic, (1962) the root of writings on taxation dates back to more than 3,500 years and is traceable to an Iraqi citizen who wrote that: - "..... you can have a lord, you can have a king, but the man to fear is the tax collector". The tax system is an opportunity for government to collect additional revenue needed in discharging its pressing obligations. A tax system offers itself as one of the most effective means of mobilizing a nation's internal resources and it lends itself to creating an environment conducive to the promotion of economic growth.

Nzotta (2007) argues that taxes constitute key sources of revenue to the federation account shared by the federal, state and local governments. This is why Odusola (2006) stated that in Nigeria, the government's fiscal power is divided into three-tiered tax structure between the federal, state and local governments, each of which has different tax jurisdictions. The system is lopsided and dominated by oil revenue. He further argues that over the past two decades oil revenue has accounted for at least 70% of the revenue, thus indicating that traditional tax revenue has never assumed a strong role in

the country's management of fiscal policy. Instead of transforming the existing revenue base, fiscal management has merely transited from one primary product-base revenue to another, making the economy susceptible to fluctuations of the international market.

Tax management in this context refers to the way and manner upon which the various tax authorities are able to raise the expected amount of revenue and manage it to the extent that in the end it is able to impact on the economic growth of the Nation. The political, economic and social development of any country depends on the amount of revenue generated for the provision of infrastructure in that given country (Agung & Ford, 1998). However, one means of generating the amount of revenue for providing the needed infrastructure is through a well structured tax system.

Economic growth is defined as an increase in the capacity of an economy to produce goods and services, compared from one period of time to another (Xu, 2000). Economic growth can be measured in nominal terms, which include inflation, or in real terms, which are adjusted for inflation. Economic growth is usually associated with technological changes. The growth of an economy is thought of not only as an increase in productive capacity but also as an improvement in the quality of life to the people of that economy. Economic growth has the indirect potential to alleviate poverty, as a result of a simultaneous increase in employment opportunities and increase labour productivity (Victor, 2001)

Statement of Problem

Ordinarily, the utilisation of the resources of any economy, through public expenditure, should lead to poverty reduction, improvement in the standard of living of its citizens, mitigation of inequalities in income distribution and improve the general well being and economic development of the economy. This is however not the case in Nigeria, as there is a perceived case of poor management and administration of taxes, high rate of tax evasion and avoidance among the citizenry, and high rate of poverty (Marshal, 2000).

The dependence on oil in Nigeria has made government at all levels in the federation reluctant about tax collection (Appah, 2010). Instead of looking inwards to generate revenue from taxation and manage tax effectively, government rely heavily on the revenue generated from crude oil sales. Tax is an important means of generating revenue by any government if well

managed. According to a Central bank of Nigeria report (CBN 2010) about 60 per-cent of the population live in abject poverty. Before the debt forgiveness of 2006 the country was listed among the heavily indebted nations of the world with the external debt stock standing at a whopping \$37.5 billion (Okonjo-Iweala 2006). About 60 percent of the population lives on less than US\$1 per day. This is in spite of astronomical increases in public expenditure over the years.

The concerns regarding equity and poverty alleviation added another important dimension to public expenditure in terms of redistribution of Income. The poor growth performance of the Nigerian economy since 1986 has generated interest in issue of growth and development. Research work from the financial sector, academia, the private and public sectors of the economy, as well as from the International financial community have focused on the issues of financial sector growth and economic growth.

Fraudulent personel in the Tax offices also sabotage the effort of government to raise revenue through taxation, a large proportion of the income generated through taxes and levies do not get into the hands of government as such citizens are deprived of basic amenities and infrastructural developments needed to boast economic activities. Poor tax management is therefore a major cause of poverty among the populace. It is against the issues raised above that called for undertaking this study to determine the impact that taxation has on the economic growth of Nigeria.

Objectives of the Study

The objectives of this study include the following:

- I. To determine the impact of Tax management on the economic growth of Nigeria.
- II. To determine the effect of Tax evasion and avoidance on the Nigerian economy.
- III. To ascertain the role of tax management in the alleviation of poverty in Nigeria.

LITERATURE REVIEW

Theoretical Framework

According to Bhartia (2009), a taxation theory may be derived on the assumption that there need not be any relationship between tax paid and benefits received from state activities. In this group, there are two theories, namely,

- a) Socio-political theory
- b) The expediency theory

Socio political theory

This theory of taxation states that social and political objectives should be the major factors in selecting taxes. The theory advocated that a tax system should not be designed to serve individuals, but should be used to cure the ills of society as a whole.

Expediency theory

This theory asserts that every tax proposal must pass the test of practicality. This must be the only consideration weighing with the authorities in choosing a tax proposal. Economic and social objectives of the state and also the effects of a tax system should be treated accordingly (Bhartia,2009).

Benefit received theory

According to this theory, the state should levy taxes on individuals according to the benefit conferred on them. The more benefits a person derives from the activities of the state, the more he should pay to the government. This principle has been subjected to severe criticism on the following grounds:

Firstly, If the state maintains a certain connection between the benefits conferred and the benefits derived. It will be against the basic principle of the tax. A tax, as we know, is compulsory contribution made to the public authorities to meet the expenses of the government and the provisions of general benefit. There is no direct *quid pro quo* in the case of a tax.

Secondly, most of the expenditure incurred by the state is for the general benefit of its citizens, it is not possible to estimate the benefit enjoyed by a particular individual every year.

Thirdly, if we apply this principle in practice, then the poor will have to pay the heaviest taxes, because they benefit more from the services of the state. If we get more from the poor by way of taxes, it is against the principle of justice?

This theory proceeds on the assumption that there is basically an exchange relationship between tax-payers and the state. The state provides certain goods and services to the members of the society and they contribute to the cost of these supplies in proportion to the benefits received (Bhartia, 2009).

Cost of service theory

Some economists are of the opinion that if the state charges actual cost of the service rendered to the people, it will satisfy the idea of equity or justice in taxation. The cost of service principle can no doubt be applied to some extent in those cases where the services are rendered out of prices and are a bit easy to determine, e.g., postal, railway services, supply of electricity, etc. But most of the expenditure incurred by the state cannot be fixed for each individual because it cannot be exactly determined. For instance, how can we measure the cost of service of the police, armed forces, judiciary, etc., to different individuals? Dalton has also rejected this theory on the ground that there is no quid pro qua in a tax.

Ability to pay theory

The most popular and commonly accepted principle of equity or justice in taxation is that citizens of a country should pay taxes to the government in accordance with their ability to pay. It appears very reasonable and just that taxes should be levied on the basis of the taxable capacity of an individual. For instance, if the taxable capacity of a person A is greater than the person B, the former should be asked to pay more taxes than the latter.

According to Anyanfo (1996), this theory states that one should be taxed according to the ability to pay. It is simply an attempt to maximize an explicit value judgment about the distributive effects of taxes. Bhartia (2009) argue that a citizen is to pay taxes just because he can, and his relative share in the total tax burden is to be determined by his relative paying capacity.

It seems that if the taxes are levied on this principle, then justice can be achieved. However, the difficulties do not end here. The fact is that when this theory is put in practice, our difficulties actually begin. The trouble arises with the definition of ability to pay. Economists are not unanimous as to what should be the exact measure of a person's ability or faculty to pay. The main viewpoints advanced in this connection are as follows:

(a) Ownership of Property: Some economists are of the opinion that ownership of the property is a very good basis of measuring one's ability to pay. This idea is out rightly rejected on the ground that if a person earns a large income but does not spend on buying any property, he will then escape taxation. On the other hand, another person earning income buys property, he will be subjected to taxation. It is therefore absurd and unjustifiable that a person, earning large income is exempted from taxes and another person with small income is taxed?

(b) Tax on the Basis of Expenditure: It is also asserted by some economists that the ability or faculty to pay tax should be judged by the expenditure which a person incurs. The greater the expenditure, the higher should be the tax and *vice versa*. The viewpoint is unsound and unfair in every respect. A person having a large family to support has to spend more than a person having a small family. If we make expenditure as the test of one's ability to pay, the former person who is already burdened with many dependents will have to pay more taxes than the latter who has a small family.

(c) Income as the Basis: Most of the economists are of the opinion that income should be the basis of measuring a man's ability to pay. It appears very just and fair that if the income of a person is greater than that of another, the former should be asked to pay more towards the support of the government than the latter. According to Nwachukwu (2007), in the modern tax system of the countries of the world, income has been accepted as the best test for measuring the ability of a person to pay tax.

Principles of Taxation

According to Adam Smith in his famous book "the wealth of Nation "1776, he defined principle of taxation as rules, reasons, qualities and conditions that

is behind a particular tax or tax system. He propounded four rules of taxation – Equality, Certainty, Convenience and Economy.

(1) Canon of equality or ability: Canon of equality or ability is considered to be a very important canon of taxation. Equality does not mean that people should pay equal amount by way of taxes to the government. By equality is meant equality of sacrifice that is people should pay taxes in proportion to their incomes. This principle points to progressive taxation. It states that the rate or percentage of taxation should increase with the increase in income and decrease with the decrease in income. In the words of Adam Smith:

The subject of every state ought to contribute towards the support of the government as early as possible in proportion to their respective abilities that is in proportion to the revenue which they respectively enjoy under the protection of the State.

(2) Canon of certainty: The Canon of certainty implies that there should be certainty with regard to the amount which taxpayer is called upon to pay during the financial year. If the taxpayer is definite and certain about the amount of the tax and its time of payment, he can adjust his income to his expenditure. The state also benefits from this principle, because it will be able to know roughly in advance the total amount which it is going to obtain and the time when it will be at its disposal. If there is an element of arbitrariness in a tax, it will then encourage misuse of power and corruption, Adam Smith in this connection remarks that:

The tax which each individual is bound to pay ought to be certain and not arbitrary. The time of payment, the manner of payment, the quantity to be paid all ought to be clear and plain to the contributor and to every other person.

(3) Canon of convenience: By this canon, Adam Smith means that the tax should be levied at the time and the manner which is most convenient for the contributor to pay it. For instance, if the tax on agricultural land is collected in instalments after the crop is harvested, it will be very convenient for the agriculturists to pay it. Similarly, property tax, house tax, income tax, etc., should be realized at a time when the taxpayer is expected to receive income. The manner of payment of tax should also be convenient. If

the tax is payable by cheques, the contributor will be saved from much inconvenience. In the Words of Adam Smith:

"Every tax ought to be levied at the time or in the manner in which it is most likely to be convenient for the contributor to pay it".

(4) Canon of Economy: The canon of economy implies that the expenses of collection of taxes should not be excessive. They should be kept as little as possible, consistent with administration efficiency. If the government appoints highly salaried staff and absorbs major portion of the yield, the tax will be considered uneconomical. Tax will also be regarded as uneconomical if it checks the growth of capital or causes it to immigrate to other countries, in the words of Adam Smith:

"Every tax is to be so contrived as both to take out and keep out of the pockets of the people as little as possible over and above what it brings into the public treasury of the state".

Conceptual Framework

Taxation as the name suggests is an important source of revenue to government of any nation. According to Dandago and Alabede (2001), taxation is a compulsory levy made by eligible individuals and corporate bodies to government in order to enable it render services to the citizens. However, Ochiama (2008) says, taxation is a controversial issue and it is not just an economic instrument designed to generate revenue for development purposes. It is also a political weapon that threatens the stability of any administration. One can readily recall to mind, the Aba women's Riot of 1929, the then colonial Administration in Nigeria did not quite find it funny and tax was at the root of it (Ochiama 2008). Such is the importance of taxation that a onetime United State president, Benjamin Franklin said that there were only two certainties in life and they are death and taxes (Ochiama, 2008).

Tax Avoidance

This is defined as taxpayer's effort to avoid paying tax by finding a legal loophole in the tax system. It is a deliberate legal act and one of the ways of doing it is by taking on life assurance policies (Appah, 2010).

Tax Evasion

This is an illegal attempt by taxpayer not to pay tax. One of the methods is by not declaring all of one's earnings and under estimation of earning.

Tax Delinquency

According to Marshall, (2002), tax delinquency is any act of tax malpractice either by the tax payer or the tax officials which will have adverse effect on the administration of tax. It may take form of tax evasion, tax avoidance or fraudulent manipulation of the account especially by tax payer.

The Concept of Economic Growth

Onaolopo (2013), defined Economic growth as an increase in the capacity of an economy to produce goods and services, compared from one period of time to another. Economic growth can be measured in nominal terms, which include inflation, or in real terms, which are adjusted for inflation. Economic growth is usually associated with technological changes. The growth of an economy is thought of not only as an increase in productive capacity but also as an improvement in the quality of life to the people of that economy.

According to Dwivedi (2004), economic growth is a sustained increase in per capita national output or net national product over a long period of time. It implies that the rate of increase in total output must be greater than the rate of population growth. Another quantification of economic growth is that national output should be composed of such goods and services which satisfy the maximum want of the maximum number of people. Economic growth can be determined by four important determinants namely, human resources, national resources, capital formation and technological development. Strategic planning should be combined with the development of a new set of economic growth indicators for tax administration and management, which, instead of exclusively measuring tax collection results, evaluate tax administration and management along side with economic growth in the various operational areas, including the improvement of taxpayer services.

Tax Management and Poverty Alleviation in Nigeria

There are variations in living standards around the globe, as economic growth rates and productivity vary from nation to nation. Some countries are poor, some are fairly well off, and others are rich, just as some individuals are poor, some are fairly well off, and others are considered rich. However, everything is relative and that is certainly the case with poverty. What most people in the United States today regard as "stark poverty would seem like luxury in parts of Asia and Africa..."Victor, (2001).

Similarly, a poor person in Nigeria might not be perceived as such by other Africans in their economic needs. Thus, poverty is partly a matter of how one person's income stacks up against the other person. He further classifies modern poverty into two, namely: Case Poverty, and Insular Poverty. *Case Poverty* is the kind of poverty seen in every community - rural and urban. It manifests in poor family with "junk-filled yard and dirty children playing in the bare dirt". Other qualities peculiar to the individuals or family afflicted by *Case* poverty are: mental deficiency, bad health, inability to adapt to the discipline of modern economic life, excessive procreation, alcohol, insufficient education, or perhaps a combination of several of these handicaps. These conditions hinder these individuals from participating in general wellbeing in their life. Insular Poverty on the other hand manifests itself as an Island. In this imaginary island everyone or nearly everyone is poor. He also noted that it is not easy to explain insular poverty by individual inadequacy, because the environment in which the people found themselves may have made them poor or may have frustrated them.

According to Ukpong (1996), Poverty is an enemy of man; it humiliates and dehumanizes its victim. Poverty has been a serious challenge to governments in Nigeria. Its effect which includes lack and deprivation in the basic necessities of life is worrisome. Therefore, capacity to raise taxes and manage it is one of the core foundations of both economic growth and political development.

It was noted by Ojo (1999), that if the system of tax management in the country is improved upon and evasion reduced, then the tax system would have the capacity to reduce poverty in the country. Therefore, evasion of tax is an illegal act and deliberate violation of tax law by the tax payers

(Marshall, 2002). Ochiama (2008) stressed that tax evasion is usually considered a crime heavily punishable by the state. According to Nwachukwu, (2007), the issue of tax evasion is reported to be generally taking centre stage in Nigerian tax system. Ahmed (2009) is of the view that only workers in the formal sector pay taxes, while the rich billionaire and corporate organization evade taxes. Barro (1991), is of the view that evasion of tax appears to be widespread in developing and developed countries in which it has two serious implication; first, it lead to a loss in tax revenue for the government which would otherwise be used for many constructive notice, Secondly, it may reduce the progressiveness of tax system, thus, altering the after tax income distribution.

Tax Management and Economic Growth of Nigeria

Tax plays an important role in Nigeria society. Akpan (2005), stated that taxation has been a strong force for economic growth in the country from the pre-colonial, colonial and post-colonial eras. Revenue generated from tax is used by the government to carry out its expenditure programmes which includes: Defense, social and infrastructural services general administration etc. For government to effectively carry out these obligations, a lot of revenue will be required. Revenue generated from oil and non-oil source cannot be enough to execute these enormous tasks, hence tax revenue which is believed to be a significant source of revenue to the government is of great importance. Appah (2010), revealed that the dependence on oil in Nigeria has made government at all levels in the federation reluctant about tax collection. This has contributed to the high level of poverty and inadequate provision of social amenities in the nation. The CBN report of 2011 revealed that about 60 percent of the population lives on less than US\$1 per day. This is in spite of astronomical increases in public expenditure over the years. Onaolapo (2013), stressed that the poor management of taxation in Nigeria has hindered the economic growth of the country.

One of the principles of Taxation is Economy which requires that, the cost of collection should not be higher than the revenue raised. This is with the expectation that, the collection of tax should be economic, efficient and effective. According to Ojo (1999), the available records in Nigeria have put the cost between 1% and 1.5% at the federal level. Indeed, it has however reported that the cost is between 5% and 7.5% in Ghana which shows that

the Nigerian tax management is relatively efficient at federal level. But he further said, the weak link is the position in the states of the federation where tax consultants are been used and as such; the cost is not comparable as this may range between 15% and 25% in most state of the federation.

According to Agung and Ford (1998), Taxation systems in developing countries face big challenges: - There is a fundamental shift in revenue sources away from trade customs/tariffs towards domestic taxation (primarily VAT), but developing countries are losing out because they are unable or unwilling to increase revenue sufficiently from domestic taxes. The tax base (especially for corporate taxes) must be broadened. They conclude that, - International tax fraud, evasion and avoidance (such as through transfer pricing and thin capitalization) pose a major threat, requiring both a technical response and joined up working with international initiatives to address global governance issues. Tax is indispensable but its economic growth has to be improved to generate sufficient revenues for development.

In his view Xu, (2000) said taxation is not a matter of policy application but also how it is administered and managed shapes growth dynamics. Fiscal pacts are often one of the foundations of sustainable peace, political reconciliation and capable states. Tax is highly political and its administration is one of the largest government organizations, depending on developing clear and transparent relations with the legislature and civil society. Strengthening transparency and accountability in tax policy and administration, and linking it better to expenditure, provides an important contribution to improving political governance. Sound and fair domestic taxation systems promote good governance because it is hard to raise tax without bargaining with citizens.

Ogbonna and Appah (2012), are of the opinion that the tax management of any nation plays a significant role in the economic growth of such nation. Any country with a poor tax management system is unlikely to grow economically. This is because taxation is a viable instrument used by government in the alleviation of poverty and provision of basic amenities in any state.

DISCUSSION

Every government is charged with the responsibility of providing its populace with the basic infrastructure and amenities needed for survival and economic development. These amenities include electricity, pipe-borne water, hospitals, schools, access roads as well as a rise in per capital income and poverty alleviation among others. The economic growth of any state depends largely on how the taxes collected by its government are properly managed to provide amenities and infrastructure necessary for economic activities to thrive. A tax system offers itself as one of the most effective means of mobilizing a nation's internal resources and it lends itself to creating an environment conducive to the promotion of economic growth.

Over the past two decades oil revenue has accounted for at least 70% of the revenue, thus indicating that traditional tax revenue has never assumed a strong role in the country's management of fiscal policy. Instead of transforming the existing revenue base, fiscal management has merely transited from one primary product-base revenue to another, making the economy susceptible to fluctuations of the international market.

Economic growth is usually associated with technological changes. The growth of an economy is thought of not only as an increase in productive capacity but also as an improvement in the quality of life to the people of that economy.

In Nigeria, there is a perceived case of poor management and administration of taxes, high rate of tax evasion and avoidance among the citizenry, and high rate of poverty.

The dependence on oil in Nigeria has made government at all levels in the federation reluctant about tax collection. Instead of looking inwards to generate revenue from taxation and manage tax effectively, government rely heavily on the revenue generated from crude oil sales. Tax is an important means of generating revenue by any government if well managed.

According to a Central bank of Nigeria report (CBN 2010) about 60 per-cent of the population live in abject poverty. Before the debt forgiveness of 2006 the country was listed among the heavily indebted nations of the world with the external debt stock standing at a whopping \$37.5 billion (Okonjo-Iweala 2006). About 60 percent of the population lives on less than US\$1 per day. This is in spite of astronomical increases in public expenditure over the years.

The result of the study shows that tax management has a significant impact on the economic development of the country. To achieve this however, efforts must be made by the government to improve the tax management system and check the menace of tax evasion.

SUMMARY AND CONCLUSION

The study shows that tax management plays a major role in the economic growth of any Nation. However, the peculiar case in Nigeria is that of poor administration of tax as a result of dependence on oil. In many countries of the world, taxation is seen as the most important source of revenue to the government. In Nigeria the attention of government is on oil and this has led to poor monitoring of the tax authorities. This has in turn made some of the tax payers not to cooperate by supplying information to the revenue board for their tax liabilities to be computed especially self-employed people. The rate of tax evasion is therefore high in the country as such government is unable to provide the needed infrastructure and amenities for economic activities to thrive. Tax systems need to focus much more on how taxation regimes can be developed to promote transparency, capacity, accountability and responsiveness that together create the legitimacy and effectiveness of the state and improve tax efficiency, management and equity.

Recommendations

- 1) It is recommended that the Nigerian government should take necessary steps to sensitize the populace on the importance of tax to economic growth. This study has shown that there is a wide information gap in Nigerian tax system which has encouraged tax evasion and avoidance.
- 2) Nigerian tax management system should be improved upon. It is expected that if tax management can be improved upon in the country, economic activities would get a boost thereby improving the standard of living of the populace.
- 3) Improving corporate and personal income tax to preserve its role in a changing economic environment. This will require efforts to broaden the base of the tax and to review and streamline the system of tax incentives and preferential tax regimes.

- 4) The Tax Base of the informal sector should be broadened. The informal economy forms a large part of the economies of many developing countries. However, operating in the informal economy can have major drawbacks. The creation of special tax offices to administer and serve small taxpayers and the introduction of simplified tax rules can help to implement this recommendation.
- 5) The government should also look at the laws currently in use and think of areas where amendments are necessary based on societal changes.
- 6) Tax collectors who work with the Federal Inland Revenue Service as well as all other organs of government responsible for tax collection should be adequately trained and re-trained to face the current challenges in tax administration.

REFERENCE

- Agung, F. & Ford, J. (1998). *Financial Development, Liberalization And Economic Development in Indonesia 1966-1996: Co- integration and Causality*, University Of Birmingham, Department Of Economics Discussion Paper No: 98-12.
- Akpan, N. I. (2005). Government Expenditure and Economic Growth in Nigeria: A Disaggregated Approach. *CBN Economic and Financial Review*, 43(1).
- Alabede, J. O. (2001). *Introduction to Nigerian Taxation*: Debis Co. Press Publishing Company Ltd.
- Anyanfo, A. (1996). *Public Finance in a Developing Economy: The Nigerian Case*. Department of Banking and Finance, University of Nigeria, Enugu.
- Appah, E. (2010) The Problems of Tax Planning and Administration in Nigeria: The Federal and State Governments Experience. *Int. Journal of Lab. Organ. .Psychol.*, 4(2), 1-14.

- Barro, R. (1991). Economic Growth in Cross-Section of Countries. *Quarterly Journal of Economics*, 106(2), 98-116.
- Bhartia, H. L. (2009). *Public Finance*. (14th Edition). Vikas Publishing House PVT Ltd, New Delhi.
- Blanchard, F. (2007). *Survey Research Method*. Belmont, California, USA, Wadsworth publishing company Inc.
- CBN (2010) Central Bank of Nigeria Statistical Bulletin 2010.
- CBN (2011) Central Bank of Nigeria Statistical Bulletin 2011.
- CITN (Chartered Institute of Taxation of Nigeria), (2002). *CITN Nigerian Tax Guide Statutes*, Lagos, the Chartered Institute of Taxation of Nigeria.
- Dandago, K. I. & Alabede, J. O. (2001). *Taxation and Tax Administration in Nigeria*. Kano, Triumph Publishing Company Kano, Nigeria.
- Dwivedi, D. N. (2004). *Managerial Economics*. (6th Edn). New Delhi, Vikas Publishing House PVT Ltd., New Delhi.
- Illersic, A. B. (1962). The Taxation of Capital Gains. *Journal of Political Economy*, 98(5), 103-125.
- Marshall, U. E. (2000). *The Impact of Tax Delinquency in the 21st Century of Tax Revenue Generation in Nigeria*. Thesis, Ahmadu Bello University Zaria, Accounting Department.
- Nwachukwu, I., (2007). *Tax Administration: The Challenge of Equity in Nigeria*, available at [http / Business Day Online .com.](http://BusinessDayOnline.com), 1- 3.
- Nzotta, S. M. (2007). Tax evasion problems in Nigeria: A critique. *Journal of Accounts and Finance*, 40(2), 40-43.

- Ochiama, C. (2008). *New Tax Regime: Tiger by Tail*, in the Daily News paper
- Oduola, A. (2006). *Tax Policy Reforms in Nigeria*, in a Research Paper No, 2006/03, Finland, United Nations University – World Institute for Development of Economic Research. of 18th October.
- Ogbonna G. N. and Appah E. (2012) Impact of Tax Reforms and Economic Growth of Nigeria: A Time Series Analysis
- Ojo, S. (1999). Issues on Tax Management and Administration in Nigeria. *The Nigerian Financial Review*, 8(1), 49 – 58.
- Onaolapo A. (2013). The Analysis of the Effect of Petroleum Profit Tax on Nigerian Economy. *Asian Journal of Humanities and Social Sciences (AJHSS)*, 1(1), 20-32.
- Victor, E. D. (2001). *The Global Economy and Poverty in Nigeria*, Zaria, Ahmadu Bello University Press.vol. 23 No. 1 Tuesday November,17, Pp. 1 and 5.
- Xu, Z., (2000). Financial development, Poverty alleviation, and Economic growth. *Economic Inquiry*, 38 (2), 332- 345.

PERSONAL INCOME TAX AND ENTREPRENEURIAL DEVELOPMENT IN OGUN STATE, NIGERIA

By

1. OLABISI Jayeola

Department of Accounting,
College of Management Sciences,
Federal University of Agriculture, Abeokuta,
Ogun State, Nigeria

&

2. OLADUNJOYE, T. OLAWALE

Centre for Entrepreneurship Development
Yaba College of Technology, Yaba, Lagos

&

3. BABATOLU, A. T.

Department of Accounting,
College of Management Sciences,
Federal University of Agriculture, Abeokuta,
Ogun State, Nigeria

PERSIONAL INCOME TAX AND ENTREPRENEURIAL DEVELOPMENT IN OGUN STATE, NIGERIA

ABSTRACT

The study investigates the relationship that exists between Personal Income Tax (PIT) and Entrepreneurial Development (ED) in Ogun States, Nigeria. The variables used to proxy Personal Income Tax are Multiple Taxes (MT) and Administrative Corruption (AC) of tax officials. A structured questionnaire was administered on purposively selected two hundred and sixty-five (265) entrepreneurs in the state out of which two hundred and thirty- two (232) were properly filled and returned. The data collected were analyzed using the Analysis of Variance and Regression. The results of the study showed that there was a statistical significant relationship between MT and ED in the states ($p=0.000<0.05$), and correlation related to rampant multiple taxes revealed a strong positive correlation with entrepreneurial

development (.788). In addition, the results also indicated that the correlation related to Administrative corruption of tax officials was positive with entrepreneurial development (.546) and is statistically significant ($p=0.000<0.05$). The study revealed that personal income tax has a consequential effect on entrepreneurial formation, growth and survival in Ogun State, Nigeria. The study recommended a degree of uniformity in tax rate coupled with a clear line of local levies devoid of multiple taxes that will moderately affect the cost of doing business in the state.

Key- words: Personal Income Tax, Entrepreneurship Development, Economic Growth, Multiple Taxes, Administrative Corruption.

INTRODUCTION

Entrepreneurial development has been identified as a source of economic growth (Asikhia, 2009), innovation (Block and Sander, 2009), and competitiveness (Samuelson, 2009). It plays an important role in poverty alleviation (Asikhia, 2013). However, entrepreneurial development does not occur in a vacuum, it requires enabling and conducive environment for survival. Entrepreneurial development needs the combination of social, cultural, political factors within the environment to thrive. Early studies revealed that pro-market government policies nurtured high level of entrepreneurial development (Baumol, 1990; Acs and Amoros 2008; Adofu and Audu, 2010). It has been observed that in places where these policies are inadequate, the rate of entrepreneurial development will be stunted. The assumption all over the world is that government has the sole responsibility to provide employment for every able body individual and create enabling economic environment for business to thrive. The economic reality has

shown that government alone cannot generate full employment for the entire population of those who are willing to work (Essia, 2005). There is no gain saying that the government has the economic machinery to stem the rate of unemployment by formulating policies that stimulate individual to embark on small scale businesses. One of the Nigerian government's responses to stemming the spate of unemployment is the promotion of entrepreneurial activities. Government policy supports the establishment of small and medium scale enterprises and their promotions (Ayoola, 2003 and Bakare 2011). However, a number of factors within the economic environment undermine government's efforts to stimulate entrepreneurial development, thus exhibiting the tendency to stifle the initiatives of prospective and operating entrepreneurs. Chiefs among them are multiple taxes imposed by the tiers of government and bureaucratic corruption of tax officials considered to be of grave economic challenge within the Nigerian economic environment context (Agbaje and Bamiji, 2005).

Personal Income Tax (Amendment) Act 2011 imposes tax on individuals (including family), sole traders (including entrepreneurs), trustees, executor, estates and agents. The Act regulates the assessment and collection procedures in respect of personal income tax. The administrative bodies instituted by Personal Income Tax Act (PITA) to do these activities are State Board of Internal Revenue (SBIR) and Federal Board of Inland Revenue (FBIR) at the state and federal levels respectively (Agbetunde, 2010). The issue of multiple taxations has been of economic concern to business community in Nigeria for several years and various efforts made by the government to tackle this menace remains futile, affecting the conduct of business and the movement of goods and services. This is particularly detrimental to business survival as it increases the cost of doing business in Nigeria. It equally discourages local trade and investment thus, impairing the integration of internal markets and the establishment of a fully integrated economic space within Nigeria (Islam, 2003). The global average tax shows that Nigeria presently has one of the highest corporate tax rates in the world (Bello, 2012). The global average tax rate is about 25.51 per cent while Nigeria's average rate is about 30 per cent (Bello, 2012). The investment climate in Nigeria is characterized by a regime of multiple taxes imposed by different tiers of government, unpredictability, high operational costs and bureaucratic bottleneck among others (Ashogbon, and Ejike, 2008). The issue that arises now is whether the present tax regime

influences entrepreneurial development in the State or not. Hence, the inconclusive and inconsistent results of previous studies as to the extent of influence of PIT on entrepreneurial development call for further investigation.

The general objective of this study is to investigate the relationship that exists between PIT and Entrepreneurial Development in Ogun State, Nigeria. The specific objectives of the study are to:

- i. assess the relationship that exists between multiple taxes and entrepreneurial development in Ogun State, Nigeria; and
- ii. determine the relationship that exists between administrative corruption of tax officials and entrepreneurial development in Ogun State, Nigeria.

In other to achieve the objective of the study, following the background is section 2 that dealt with the review of related literature, while section 3 concerned methodological issues. Section 4 presented the results of analysis and drew conclusion from the study.

2.0 LITERATURE REVIEW

2.1 Concepts of Taxation and Entrepreneurial Development

Taxation represents a coercive transfer of property from taxpayers to the government (Ashogbon, and Ejike, 2008). As such, taxation is not and cannot conceivably be made neutral of the market. By neutrality to the market it is inferred that a situation arises in which the firm functions as part of the market. This can be the case only in so far as the individual or the firm in question works within the framework of private property rights and freedom of contract (Altshuler and Averbach 1990). Taxation is a coercive interference with private property rights and thus the attempt to reconcile taxation with the market has not received universal acceptability among scholars. On the other hand, mainstream economists define tax neutrality differently (Ukpon, 2012). They observe tax neutrality as those that do not change the behaviour of agents who are affected by them. Yet the purpose of taxation is to transfer property from an individual to someone else and make possible a different use of resources than that which would otherwise take place.

Thus taxation could not be conceivably made neutral even if we adopted the mainstream approach to tax neutrality. Although there exists what we call corporate taxation, each and every penny of each and every tax levied is paid by individuals. Corporations and all other legal entities exist only as special contractual arrangements that involve different groups of individuals. And as we know, no written or oral contract can pay taxes. In the same manner, what we call government is but a set of individuals bound by certain contractual arrangement that gives to these individuals – among other things – the power to tax. Different modes of taxation affect individuals in different manners and different levels of taxation distort market activities to a greater or lesser degree (Ukpon, 2012). Whether we call the latter neutrality or not, the impact of different types of taxes on the welfare and actions of individuals is definitely worth investigating. As far as the quantitative aspect of taxation is concerned, one can conclude rather easily, the more heavily an activity or goods are taxed, the greater the effects of this tax are (Adofu and Audu, 2010). If the tax rate on wage income was hundred percent, no one would exercise any work at all. In contrast, if the tax rate tends towards zero percent, its influence on the decisions taken by persons affected tends to be negligible. If we consider tax on wage income, the rate at which taxes affect employees' decision to work and the extent to which corporate income tax change firms' decision to produce. Then the pattern of consumption tax on firms' decision to produce and consumers' decision to buy a given product are affected.

If tax is imposed on corporate income, the tax will be paid by private individuals and will therefore affect consumers' decisions. Moreover, as Lehmann, Armentieres, and Van der Linden (2009) argued, personal tax significantly reduces the volume of investment which would otherwise have been undertaken. Basic economic theory tells us that there is little difference between a personal income tax and consumption tax (Ayoola, 2003 and Bakare 2011). However, economic experts emphasize the possibility of shifting the tax burden forward (to consumers) or backward (to owners of factors of production), depending on elasticity of respective demand and supply curves. Nonetheless, there has been much controversy over the possibility of tax shifts.

The equilibrium price would of course in this case remain the same, but the tax burden would exist nonetheless. And this burden would be distributed among the loss of net income for the seller and a higher price for the

customer. The result would be a lower quantity of the good in question at a higher price for the consumer and a lower “price” collected by the seller. It is difficult to accept Rothbard (1977) claim that price cannot be raised at all, for it holds only in a particular situation of a perfectly elastic consumer demand. In the setting of traditional firm theory, the firm in question faces the same profit maximizing problem, irrespectively of whether it pays a personal income tax or an ad valorem consumption tax. Both can indeed be shifted forward and backward, depending on the elasticity of the product or service in question.

It is assumed that there exists a need for government intervention and supply of those goods that bring about a Pareto improvement. It is not the purpose of the present work to analyse the concept of public goods, though it is highly questionable. In particular, it is believed that the concept is not meaningful to describe phenomena of the real world and that there are serious logical fallacies in the usual normative inferences. In other words, there is a serious doubt about the possibility of bringing about a Pareto improvement by using coercive means. At this point in time, suffice it to say that the vast majority of government expenditures in Nigeria have little to do with the production of public goods, as defined by traditional economic theory. In this regard, it is wise to treat government activities and spending cautiously and not to assume their necessities.

2.2 Tax System and Entrepreneurial Development

Several studies on relationship between taxation and entrepreneurship like those of (Adofu and Audu, 2010, Ukpon, 2012, Ashogbon, and Ejike, 2008) exist. Some results of these previous studies showed that government specific tax policies on entrepreneurship potentially have positive and negative effects on entrepreneurial development (Bello, 2012). Some tax policies such as accelerated capital recovery for small businesses, target entrepreneurs, but other tax effects may arise from general tax policy choices, such as the choice of the shape of the tax rate schedule. Considering the risk of entrepreneurship, the argument is that the shape of tax schedule may play an important role in influencing entrepreneurial decisions. With a progressive income, successful ventures may face a higher tax rate than unsuccessful ventures (Ayoola, 2003 and Bakare 2011).

Tax policy can affect entrepreneurship and innovation through various channels. Broadly speaking, these channels can be categorized as effects of

general tax policies (change in marginal tax rates) and targeted tax policies (such as a tax credit for research). In assessing how general tax policies affect entrepreneurship, the critical question is: Why would the tax policy have a differential effect on entrepreneurship relative to other economic activity? For targeted tax policies, the policy design question is: Can the policy encourage the desired behavior without providing subsidies to projects that would have taken place without the targeted policy? One common hypothesis regarding the differential effects of tax rates on self-employment (one measure of entrepreneurship) and working for someone else is that higher tax rates encourage self-employment because it provides tax-sheltering opportunities (Bello, 2012). These tax-sheltering opportunities include both tax evasion (it is relatively easy to under report self-employment income) and tax avoidance (legal opportunities to deduct business-related consumption from one's taxable income). The value of these tax-sheltering opportunities increases with the tax rate, which leads to the hypothesis that higher tax rates increase the level of self-employment in the economy (Ayoola, 2003 and Bakare 2011). The tax-sheltering hypothesis provides one channel for general tax policies to affect the decision to be an entrepreneur. Imperfect loss-offset provisions provide another example of how relatively risky projects face a higher tax burden than relatively safe projects. Rather than focusing on the risk of occupational choices, the analysis of loss-offset provisions usually focuses on corporate investment.

For corporations, reporting negative taxable income does not necessarily generate a tax refund, corporations benefit from losses in one year by applying a set of tax-loss carry-back and carry-forward rules; these rules specify a limited time period over which entrepreneur can essentially average their income. These rules create another form of success tax in the tax code, whereby successful firms face a higher tax rate than unsuccessful firms face. In the extreme, if a corporation has negative taxable income in a year but does not have sufficient positive income during the carry-back or carry-forward period, then it faces a tax rate of zero on the losses; however, had the corporation been successful, it might face the top corporate tax rate of 35 percent (Altshuler and Auerbach 1990). Another channel for general tax policies to affect entrepreneurship arises because entrepreneurship is riskier than other occupational choices and because innovative investments are riskier than other possible investments (Ayoola, 2003 and Bakare 2011). Thus, tax policies that affect the returns from taking risks can have

consequences for entrepreneurship. Because the returns from entrepreneurship are relatively risky, the level of the marginal tax rate is unlikely to capture the complete effect of tax policy on entrepreneurship (Cullen and Gordon 2002; Gentry and Hubbard, 2003).

When investment is risky, the tax effects may depend on the overall shape of tax schedule, which is not captured by a local measure of the marginal tax rate. Capital gains taxation provides a final channel through which general tax policy can affect entrepreneurship. If entrepreneurial activity inherently generates more of its income as capital gains relative to other employment or investment choices, then lower capital gains tax rates may increase entrepreneurial activity. These capital gains tax effects are often discussed in the context of the taxation of venture capital.

Given the importance of entrepreneurship to the overall economy, the effects on entrepreneurship could be an important part of the overall effects of tax policy, especially if the effects on entrepreneurship are large. In contrast to the effects of general tax policies on entrepreneurship, specific tax policies can be targeted at small businesses and innovation. Such targeted tax policies include tax credits for research and development; favourable depreciation rules for the capital expenditures of small businesses; reduced capital gains taxes after the initial public offerings of qualified small-business stock; and preferential exemptions for business assets under the estate tax. The goals of these policies are aimed at promoting specific aspects of entrepreneurship or solving problems associated with taxing small businesses. For small businesses, Slemrod (2003) argues that these tax preferences may offset the high tax compliance costs relative to business size that small businesses face.

2.3 Empirical Studies on Taxation and Entrepreneurship Development

Most of the studies on the role of entrepreneurship in economic growth suggest that there is a strong relationship between the level of entrepreneurial activities in a region or country and its rate of economic growth (Carree and Thurik, 1998). The Global Entrepreneurship Monitor (GEM) in its report of 2002 also showed that the national level of entrepreneurial activity has a statistically significant association with subsequent level of economic growth. GEM data also suggests that there is

no country that has high levels of entrepreneurship and low levels of economic growth (Reynolds, 2002).

In Indian context, a study found a positive impact of the Index of Entrepreneurship on per capita income. The regression results indicate that a unit change in the value of the Index of entrepreneurship will bring Rs. 185.40 change in per capita income. Using a double log function, the study also found that one per cent change in the value of the level of entrepreneurial activity will lead to 0.05 per cent change in per capita income. More interestingly, the study also revealed that average per capita of the states with index of entrepreneurship above median is on an average higher by Rs. 6096 compared to the states with lower value of the index. The role of entrepreneurship is not confined only to creation of enterprises, but also includes creation of the capacity to produce wealth, jobs and income, which are the most direct indicators of economic development. Indeed, underdevelopment is not lack of natural resources but the absence or inadequate supply of entrepreneurs. If only natural resources are the key determinants of economic growth, the entire African continent or Latin America or most of Asia would have been developed.

Advances in the theory of taxation in recent decades have had a significant impact on public policy. Most developed countries have broadened tax bases, closed loopholes and cut marginal taxes. Capital taxation has been reformed to limit the distortionary effects on the source and use of capital, based on principles of neutrality such as those outlined in (Jaiyesimi, 2005). Economists are uniquely suited to offer guidance to policy makers in a field like capital taxation. But this strength also carries the risk of misguided advice, especially when model structures are not complete with regard to the real-life economic issues designed to address them. The scholarly study of taxation of entrepreneurship has suffered in this regard; the inherited models of capital taxation have been insufficiently adapted to the economics of owner-managed firms. With the help of neoclassical investment theory (Jorgenson, 1963; Jorgenson, 1967), it is possible to summarize the effects of multiple tax rates and rules in a few equations to describe the wedge between the effective average and marginal tax rate and the pre-tax cost of capital. However, cost of capital formulas were originally derived from the behaviour of a specific class of investors such as public firms. There is reason to surmise that the models need to be adjusted when applied to taxation of entrepreneurial firms. This class of models typically suggests that

economic distortions do not arise from the taxation of owner-managed firms' capital return, since the firm's cost of capital is unaffected by taxes in steady state. This vital conclusion is analogous to the so-called —new view - result regarding taxation on dividend for public firms, and is indeed derived from the same underlying assumptions. If the marginal investment is assumed to be financed using already existing taxed capital, the cost of capital is invariant to taxation. The same assumptions lead to the remarkable result that capital taxes are neutral between private and public firms, even when entrepreneurial income is taxed at higher rates than return from passively invested capital.

It is imperative to know that before analyzing the effect of any tax, the underlying economic process on which the tax is imposed must be carefully modeled. For instance, the cost of capital no longer acts as the only central variable when the capital and effort of the entrepreneur are complementary in production. A new entrepreneurial venture can rarely rely on external debt financing or on already taxed equity to eliminate the costs of taxation. Consequently, the simple cost of capital formulas have a tendency to underestimate the distortions caused by imposing tax on entrepreneurial firms. This difficulty in modeling entrepreneurship does not plague taxation theory alone, but embodies a general predicament in neoclassical economics (Bianchi and Henrekson, 2005). Baumol (2009), however, has recently taken significant steps toward outlining a micro founded theory of the supply of productive entrepreneurship. He adds the supply of entrepreneurship to the classical tripartite division of factors of production, land, labour and capital, in order to create a genuine four-group subdivision of the economy's inputs (Baumol, 2009).

The importance of including entrepreneurship in economic models of taxation is included by examining the so-called Nordic system of dual taxation, in which capital and labour incomes are taxed separately. Whereas most entrepreneurs in the U.S. are taxed according to individual income tax schedule, the Nordic system contains a sharp division between capital and labour income. Owners of closely held firms thus face special tax rules, which assign part of their income to capital income (taxed at a lower, flat rate) and the rest to labour income (taxed at a higher, progressive rate). It is in this context that the standard formulas for calculating capital taxation have been extensively applied to entrepreneurial firms. While the hazards of not taking entrepreneurship into account when analyzing entrepreneurial

firms is particularly salient in the case of the Nordic dual taxation system, the problem is a general one. The income generated by innovative business owners' efforts and investments differ in many respects from other economic categories. A framework for incorporating elements of entrepreneurial choice into the theory of taxation suggests that entrepreneurship is viewed as a distinct factor of production (Hessels and Thurik, 2008).

Enahoro and Olabisi (2012) examined the overall effectiveness of tax administration in relation to assessment, collection and remittance of tax in Lagos State, Nigeria using Kendall measure. Their findings confirm that tax administration affects the revenue generated by the government; also there is a significant relationship between tax administration, tax policies and tax laws which impact on entrepreneurial development in the State. It was also discovered that tax payer avoid and evade tax as a result of the corrupt practices of tax officials, this also reduces the fund made available to the government to provide infrastructure and other services needed to promote entrepreneurship in Nigeria. Enahoro, Olabisi and Dafe (2013) discovered from their study that there is no single appropriate tax system for any developing country that can be plucked off the shelf and implemented without taking into consideration tax policies, laws and administration. The trust of the study is that neglecting the entrepreneur in theories of taxation has resulted in misleading policy implications. Indeed, issues of secondary importance in the analysis of large, established firms may prove crucial when analyzing small entrepreneurial businesses.

3.0 METHODOLOGY

The study employed a cross-sectional survey where primary data were gathered at one point in time from a purposively selected two hundred and sixty- five (265) enterprises out of a total population of 1,369 discovered through a preliminary investigation by (Olunuga and Olabisi 2013). Out of two hundred and sixty- five (265) enterprises sampled only two hundred and thirty- two (232) were properly filled, returned and analyzed. The categories of enterprises were registered small and medium scale enterprises by the Corporate Affairs Commission (CAC) in Ogun State, Nigeria, 2014 and were within the definitions of National Council on Industries. The study adopted survey design through the instrument of a structured questionnaire titled 'Personal Income Tax and Entrepreneurial Development'. Responses were received to structured questions contained in the questionnaire with a 6-

point Likert scales rating starting from strongly agree, agree, slightly agree, slightly dis-agree dis-agree and strongly dis-agree. The data collected were analysed using the Analysis of Variance and Regression Analysis. The study had a scale that comprised 17 items developed by the researchers from reviewed literature and was validated. The two aspects considered most important at this level of validity were face and content validity. Regarding the face validity, effort was made to ensure that the respondents to the research instruments understand what the instrument wanted from them. The understanding concerned grammatical meaning of certain words or the direction of thoughts of the researchers. The content validity helped to ensure that the instrument measured all the adequate areas of the subject being investigated. To get this done the researchers sought assistance and advice of experts in measurement and evaluation. The study reported a crobach's alpha of 0.79

Operationalization of Variables

PIT = X (PREDICTOR VARIABLE)
VARIABLE)

ED = Y (RESPONSE

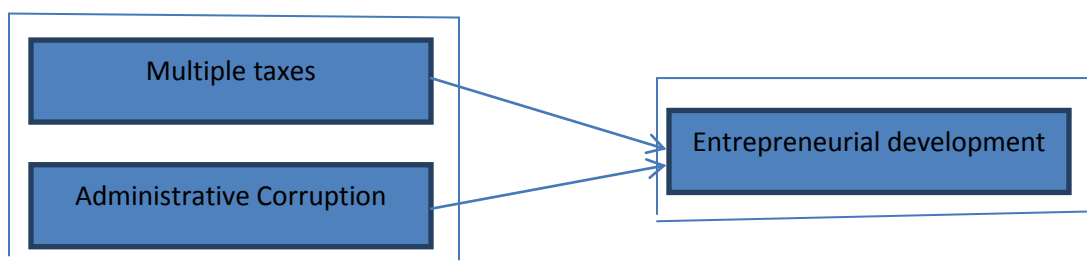

Source: Researchers' conceptual Model (2014)

Hence, the model is specified as follows:

$Y = f(X)$ where Y is Entrepreneurial Development; and
X is Personal Income Tax

$X = (x_1; x_2),$
 x_1 is Multiple taxes
 x_2 is Administrative Corruption
 Hence, $Y = f(x_1; x_2)$
 $Y = \beta_0 + \beta x_1 + \beta x_2 + e_0$

3.1 Hypothesis Testing and Interpretation of Parameter Values

From the model summary below, the correlation coefficient (R) value is .788* which implies that there is a strong positive linear association between multiple taxes and entrepreneurial development in Ogun State. With reference to the table below, it is observed that the coefficient of determination is 61.7% which means that about 61.7% of entrepreneurial development in the metropolis is explained by the considered factors that is, multiple taxes, while other factors not under investigation responsible for about 38.3%

Table 3.1 Model summary

Model	R	R Square	Adjusted R Square	Std. Error of the Estimate
1	.788 ^a	.621	.617	.701

Predictor: (constant) Multiple taxes

Source: Researchers' computation (2014)

Since the P value in the table 3.2 below (.000) is less than the specified level of significant .05 we therefore reject H_0 and conclude that there is significant relationship between multiple taxes and entrepreneurial development in the Ogun State.

Table 3.2: ANOVA

Model		Sum of Squares	Df	Mean Square	F	Sig.
1	Regression	568.341	7	81.192	165.354	.000 ^b
	Residual	346.658	706	.491		
	Total	914.999	713			

Predictor: (constant), Multiple taxes

Dependent variable: Entrepreneurial Development

Source: Researchers' computation (2014)

From the model summary below, the hypothesis tested depicted significant relationship between administrative corruption and entrepreneurial development in the Ogun State. The correlation related to administrative corruption is positive (.546) and statistically significant at (.000). The coefficient of determination was .299 which means that about 29.2% of entrepreneurial development in the state is explained by administrative corruption, while other factors not under investigation responsible for about 70.8%.

Table 3.3 **Model summary**

Model	R	R Square	Adjusted R Square	Std. Error of the Estimate
1	.546 ^a	.299	.292	.644

Predictor: Administrative Corruption

Source: Researchers' computation (2014)

From the model summary table, the correlation coefficient (R) value is .546* which implies that there is a strong positive linear relationship between administrative corruption and entrepreneurial development in Ogun State, Nigeria. With reference to the above model summary table, it is observed that the coefficient of determination is 0.299 which means that about 29.2% of entrepreneurial development in the state was explained by administrative corruption of tax officials. While other factors not under investigation responsible for about 70.8%.

Table 3.4: **ANOVA**

Model	Sum of Squares	Df	Mean Square	F	Sig.
-------	----------------	----	-------------	---	------

1	Regression	119.814	6	19.969	48.162	.000 ^b
	Residual	281.527	679	.415		
	Total	401.341	685			

Dependent variable: entrepreneurial development

Predictor (constant): Administrative corruption

Source: Researchers' computation (2014)

Since the P value (.000) is less than the specified level of significance .05 we therefore reject Ho and conclude that there is significant relationship between corporate tax and entrepreneurial development in Ogun state, Nigeria.

4.0 DISCUSSION OF THE RESULTS

The result of the study shows that a significant relationship exists between PIT and entrepreneurial development in the state. That result is valid to the extent of entrepreneurs whose businesses are formally organized, registered with the Corporate Affairs Commission and by law compelled to remit taxes to either the State Inland Revenue or Federal Inland Revenue.

The result of the study reveals that tax progressivity has a robust negative effect on entrepreneurship. Government deficits have adverse effects on growth, and government spending in the public sector does not create higher production, but the investment in private sector does, this implies that there should be initiatives to increase tax cuts for those who are likely to be most affected by inadequate credit facility, such as small and medium sized business whose entire source of fund is attached to credit facilities.

Furthermore, the result of the study indicated a positive relationship between rampant multiple taxes coupled with bureaucratic corruption of tax officials which affects entrepreneurial development in the State. It is evident from the study that a major problem facing entrepreneurs is multiplicity of taxes. Individual and corporate bodies complain about the ripple effects associated with duplication of taxes. This problem arises from the mismatch between fiscal responsibilities and fiscal powers or jurisdiction to assess and impose taxes. Some States take the initiative of imposing certain taxes, which has led to arbitrariness, harassment and even closure of businesses. One of the government efforts to rectify this ugly situation in Nigeria was the

Acts of 1998 enacted by Lagos State government. In order to control multiple taxations, the Joint Tax Board started to publish list of approved taxes and levies and declare some other unspecified illegal taxes. This has in a little way created a degree of harmony and uniformity thereby check-mating rampant taxation that had made the business environment in Nigeria so harsh for business survival.

One of the principles that guide both the imposition and design of tax is promotion of economic growth through entrepreneurial development. The negative impact arises from poor bureaucratic approach which has resulted in tax evasion by many entrepreneurs, particularly those who operate in the informal business sector in Nigeria (Ukpon, 2012). However; the results of this study revealed that the tax system in Nigeria is anti-entrepreneurial for it encompasses too many bureaucratic constraints for the entrepreneurs. The results revealed an evidence of lapses in the tax system which some entrepreneurs in the state exploit to avoid and evade tax payment. The endogenous growth theory explains economic growth which is generated by factors within the production process and induced by technological change (Todaro and Smith, 2009). The result of the study is in line with the discovery of Ashogbon and Ejike (2008) which confirmed empirical and significant relationship between taxes and entrepreneurial development in the Nigerian business environment.

The results of the study reveal the presence of imposition of multiple taxes on entrepreneurs and bureaucratic corruption of tax officials in the Ogun State, Nigeria. These have resulted into high cost of doing business by entrepreneurs within Nigerian business environment. It is observed from the results of the study that the combination of spending cuts and tax reduction should be considered as galvanized efforts for improved entrepreneurship activities in Nigeria.

4.1 Findings from the Study

- i. Rampant multiple taxes have negatively affected entrepreneurial development in the states and bureaucratic corruption among the tax officials in the states has negatively impacted entrepreneurial development.
- ii. The high tax regime in Ogun state has cumulated into high cost of producing goods or providing services and it is a disincentive to entrepreneurial development in the state.

- iii. Absence of social consensus and regulatory tax collection mechanisms has negative effect on important macro-economic policy on tax issues.

4.2 Recommendations

The study recommends a degree of uniformity in personal income tax imposition and there should be a clear line of local levies that will not impinge on the running cost of entrepreneurial activities in Nigeria. In addition, entrepreneurs should make representations to the Government through the Manufacturers' Association of Nigeria over these arbitrary imposition of multiple levies and corrupt activities of tax officials.

REFERENCES

- Acs, Z. J., & Amorós J. E. (2008). Entrepreneurship and competitiveness dynamics in Latin America. *Small Business Economics*, 31(3), 305–22.
- Adofu, M. I., & Audu, S. I. (2010). An assessment of the effect of interest rate deregulation in enhancing agricultural production in Nigeria. *Current Research Journal of Economic Theory*, 2 (2), 82-86.
- Agbaje, M., & Bamiji, K. (2005). Infrastructure and economic significant to entrepreneur's entry into business. *Journal of Rural Development* 5(2), 67-81
- Agbetunde, L. A. (2010). *Principles & practice of personal income tax*, 2nd ed. Ogun: Feetal Consulting Publishers, Ogun State, Nigeria.
- Altshuler, R., & Averbach, J. A. (1990). The significance of tax law symmetries: An empirical investigation. *Quarterly Journal of Economics* 105(February), 61-86.
- Ashogbon, O.S., & Ejike, I.M. (2008). Tax incentives; A stimuli for Nigerian entrepreneurship drive for economic development. *Economic Review* 10(3), 223-241
- Asikhia, O.U. (2009). Emotional response of small and medium scale business owners to micro finance banking in Nigeria. *European Journal of Social Sciences*. 11(4), 599 – 618.

- Asikhia, O.U. (2013). Poverty alleviation, income redistribution and rural development in developing countries; *Proceedings of 2013 International Conference on Poverty Alleviation, Income Redistribution and Rural Development in Developing Countries. School of Management and Business Studies, Lagos State Polytechnic, Ikorodu.*
- Ayoola, M.O. (2003). Infrastructure and Nigeria's economy. *Journal of Public Policy* 10 (3&4),47-86
- Bakare, A.S. (2011). The impact of interest rates policy on the performances of manufacturing sub-sector in Nigeria. *Prime Journal of Business Administration and Management* 1(8).
- Baumol, W. J. (1990). Entrepreneurship: Productive, unproductive and destructive *Journal of Political Economy*, 98(5), 893-921.
- Bello, M. (2012). Presentation of paper on "Sector Specific Incentives Policy for Nigeria; Manufacturing investments incentives" at the launching of the National Automotive Council (NAC), Abuja, 10th April.
- Block, J., & Sander, P. (2009). Necessity and opportunity entrepreneurs and their duration in self-employment: Evidence from German micro data: *Journal of Industry, Competition and Trade*, 9 (2): 117–137.
- Carree, M., Van Stel, A. Thurik, R., & Wennekers, S. (1999). The relationship between economic development and business ownership revisited. *Entrepreneurship and Regional Development*. 19(3), 281–91.
- Gentry, W. M., & R. G. Hubbard (2003). 'Success taxes', entrepreneurial entry an innovation' In: Jaffe, A. B., Josh Lerner and Scott Stern (eds.) *Innovation Policy and the Economy* - Volume 5, NBER and MIT Press.
- Cohen, S., & Ravallion, M. (2008). The developing world is poorer than we thought, but no less successful in the fight against poverty. *Policy Research Working Paper 4703, Washington, DC: World Bank.*
- Cullen, J., & Gordon, R. (2007). Taxes and entrepreneurial risk-taking: Theory and evidence for the US. *Journal of Public Economics*, 91, 1479–1505.

- Enahoro, J. A., & Olabisi, J. (2012). Tax administration and revenue generation of Lagos State government, Nigeria. *Research Journal of Finance and Accountin*, 3(5), 133-139.
- Enahoro, J. A., Olabisi, J., & Dafe, P.O. (2013). Operational performance of fiscal and monetary policies in Nigerian financial institutions. *Asian Economic and Financial Revenuer* 3(1), 62-74.
- Essia, U. (2005). Stimulating private sector development in Nigeria: The CISP approach. *Union Digest* 9 1&2.
- Bianchi, H. (2005). Venture capital: Impact on operations procedures. *Journal of Investment Studies*, 2(1)
- Hessels, J. M., Gelderen, V., & Thurik, R. (2008). Entrepreneurial aspirations, motivations and their drivers. *Small Business Economics*. 31(3).
- Idemudia, R.U.P. (2009). Enhancing collaborative development in the Niger Delta Region of Nigeria: The proxies of governance. *African Journal of Stability and Development*. 3 (1)
- Ighodaro, C.A.U. (2009). Transport infrastructure and economic growth in Nigeria. *Journal of Research in National Development* 7(2).
- Immervoll, H., Kleven, H., Kreiner, C. T., & Saez, E. (2007). Welfare reforms in European countries: A microsimulation analysis. *Economic Journal* 117(516), 1-44.
- Irving, J., & Astrid, M. (2009). Local sources of financing for infrastructure in Africa a cross-country analysis: *Policy Research Working Paper 4878, The World Bank Africa Region African Sustainable Development Front Office, Washington D.C.: World Bank*.
- Islam, B. (2006). Distance decay in employment and spatial spillovers of highways in Appalachia. Paper presented at the annual meeting of the North American Regional Science Association, Philadelphia. PA.
- Jaiyesimi, O. (2005). Inflationary trends in mix-economies: selected cases. *Journal of Journal of Economic Analysis* 6(4), 322-331

- Lehmann, E., Parmentier, A., & Van der Linden, B. (2009). Optimal income taxation with endogenous participation and search unemployment, CREST working paper 2009-01.
- Olunuga, A.O., & Olabisi, J. (2013). Cost cutting and profitability of small and medium scale enterprises in Ogun State, Nigeria. *Journal of Business Management*, 3(2), 58-72
- Rothbard, S. (1977). The elasticity of taxable income with respect to marginal tax rates: A critical review. *NBER Working Paper 15012*.
- Reynolds, P. D. (2002). Cross-national comparisons of the variation in new firm formation rates. *Regional Studies* 28: 443-456.
- Samuelson, P. (2009). Advances in Total Factor Productivity and Entrepreneurial Innovation. In Acs, Z, Audretsch, D. & Strom, R. (eds.) *Entrepreneurship, Growth and Public Policy*. Cambridge: Cambridge University Press, 71-89.
- Slemrod, J. (2003). *Small business and the tax system*: Mimeograph, University of Michigan, February 2003.
- Todaro, M.P., & Smith, S.C. (2009). *Economic Development* Tenth Edition. London: Pearson Education Limited.
- Ukpon, B. (2012). Tax-cost effect on business conduct in Lagos: Need for policy appraisal. *African Journal of Cost Accounting Practices* 5(2).
- Van Stel, A., Carree, M., & Thurik, R. (2005). The effect of entrepreneurial activity on national economic growth. *Small Business Economics*, 24(3), 311-21.