

# Design of an electrically powered bending machine: Case of Zimbabwe

**Tawanda Mushiri**

Department of Mechanical Engineering  
University of Johannesburg  
P.O Box APK 524  
Johannesburg  
South Africa

[tawandanda.mushiri@gmail.com](mailto:tawandanda.mushiri@gmail.com), [tawandamushiri123@hotmail.com](mailto:tawandamushiri123@hotmail.com)

**Definite Shumba**

Department of Mechanical Engineering  
University of Zimbabwe  
P.O Box MP167  
Mt Pleasant  
Harare  
Zimbabwe

[definiteshumba8@gmail.com](mailto:definiteshumba8@gmail.com)

**Charles Mbohwa**

Faculty of Engineering and the Built Environment  
University of Johannesburg  
P.O Box APK 524  
Johannesburg  
South Africa

[cmbohwa@uj.ac.za](mailto:cmbohwa@uj.ac.za)

## Abstract

This paper seeks to carry out design of a small scale electrically powered bending machine for a developing nation, case for Zimbabwe. The bending of metal is of great importance in the manufacture of products such as nut shelling machines and maize shelling machines. Currently being used at Company X engineering is a manual bending machine with a single operation hence this design will help to increase the number of metals being bent, an increase in the efficiency and production. The paper deals with manufacturing or bending of sheet metal by using power operated sheet bending machine. Especially discussion made the productivity analysis of manually or power operated sheet bending machine. Considering manual operation is replaced by power operated devices. It also gives information about limitation of manually operated sheet bending machine and power operated sheet bending machine. The existing machines are limited to a single operation. The aim of the research is to increase the number of bent parts and to place an adjustable table to suit the height of the user thereby reducing back pain internal injuries in the long run. The researchers visited the Company X to gather information concerning the problems faced by the employees. Material tests which are of great value were carried out and the use of software. A Plate Rolling Machine is a machine that will roll different kinds of metal sheet into a round or conical shape and a rod bending machine will roll or bend different kinds of metal sheet into right angles or circular shapes. The research aims at making it possible to do the operations on a single machine. We recommend the machine to be automated and the use of a servo motor to reduce human injuries at the workshop. Use of oils and maintenance is of great value to increase the life span of the machine

## Keywords

Bending machine, Case study, Design, Electrically powered, Rolling, metal products.

## 1. Introduction

Due to human's inability to bend metals into desired shapes and angles, nowadays we need machines to produce quality products. Each and every work of humans is reduced by a machine. We have different material properties and shapes hence the need for a machine to produce the desired shape for a particular purpose. The machine must be able to bend metals without producing a fracture. To build the machine a lot of equipment is needed. By using all this equipment, the process for making the project is faster and easier. It has been learned that learned a proper method for operating all these machines and equipment's. Choosing component material is very important, because it will affect the overall cost of the machine and the product quality. With this consideration, the researcher designed this machine with the maximum quality and low in cost. The paper is based on the principle of a motor and it is used to bend bars into curvature. The bar is bent with the help of power from the motor. The use of light and strong metals will be implemented on the project to produce a machine that can be carried and used at any place. Presently bending machines suffers from a number of drawbacks, one of them include no suitable adjustment for the different heights of the construction workers hence they suffer internal injury to their body organs (HERCULES, 1999).

### 1.1 Background

The main function of the bending machine presented in this project is production achievement of critical product which include small and medium steel, depends on Bending Machine due to product design and process needed. Higher production cost in term of tangible cost and intangible in term of process lead time and transportation. Future opportunity that presented so many kind and variety of products demanded by customers (HERCULES, 1999). The major problem at Company X is most of the machines perform one operation like bending bars only and there is no height adjustment to suit the different people using the machine. The objectives of the research are

1. To produce a bending machine which can be carried from one place to another,
2. To produce a bending machine with cost of not more than \$2000,
3. To produce a bending machine which can bend both bars and hollow circular sections and
4. To fit an adjustable stand on the machine

## 2. Literature review

A bending is widely use in automation industry. The purpose a bending machine is to bend metal into a variety of bent parts for example roller metals, bar bent metals and hollow bent metals. The attachment of the adjustable stand plays the role in productivity of producing products. Unfortunately, there is no proper bending machine with an adjustable height stand to suit the height of different users operating the machine. Most employees operate these machines in a poor posture. Moreover, the existing bending machine are big in size, consume a lot of space and they are used for big scale production.



Figure 1: Current bending machine in South Africa

### 2.1 Operation of a bending machine

Rotating plate

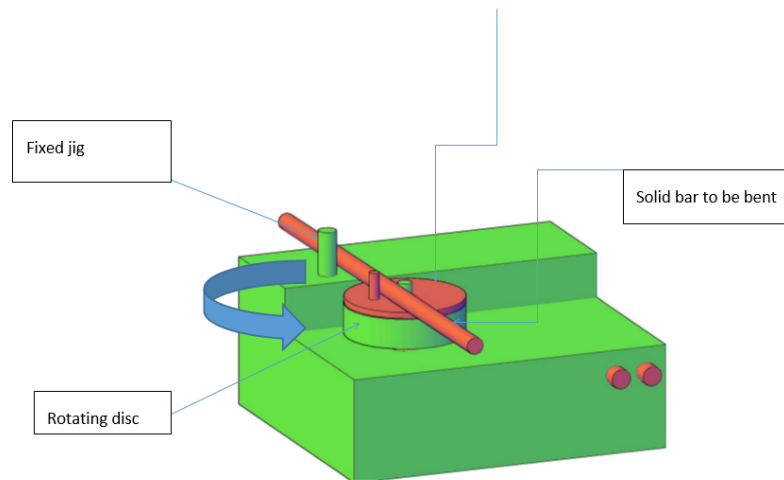

Figure 2: bending process

The rod to be bent is placed in between the two Jigs mounted on the circular plate. The motor is attached with the circular plate. The power from the motor is transferred which rotates the circular plate in anticlockwise direction. one Jig is connected to the motor and the other Jig is rotated due to the rotation of circular plate. The rod will be fixed since the fixed rod lies on the other side. Since the rod is kept in between the two Jigs, the rod would bent.

## 2.2 Existing bending machines

### 2.2.1 Press brake bending machine

Press brake bending machine use die and punch to bend a sheet metal. The die and punch of the bending machine have a variety of shape. Some of the common press brakes bending operations are bottoming, coining, air-bend, etc. Press brake bending machine is a machine that use motor to operate the bending machine. In addition, the Press brake bending machine is come with big size and use a lot of space (Amirul Farhan B Mohd Salih, 2010).

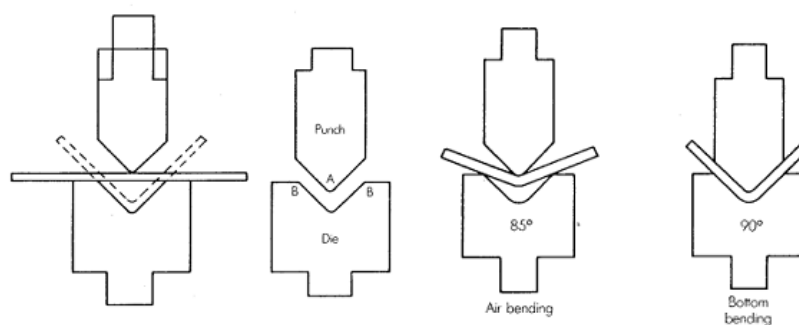

Figure 3: Square bending process

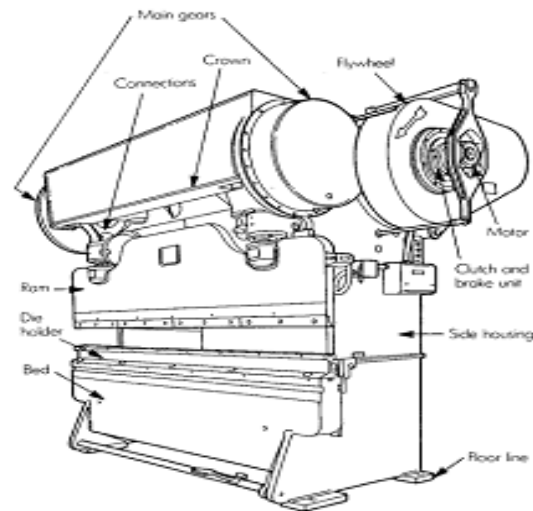

Figure 4: current machine

### 2.2.2 Roll bending machine

A roll bending machine uses roller to bend a metal. The roller of bending machine can be two rollers, three rollers, or four rollers. The common product of roll bending machine are tube bending, plate bending and a coil. All modern roll bending machine are power driven and some of the bending machine equipment with electronic control for more production system (Amirul Farhan B Mohd Salih, 2010).

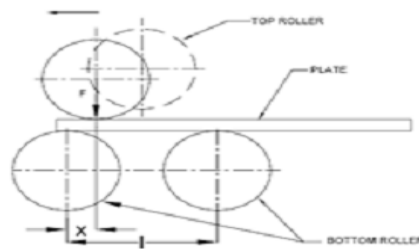

Figure 5: Rolling process

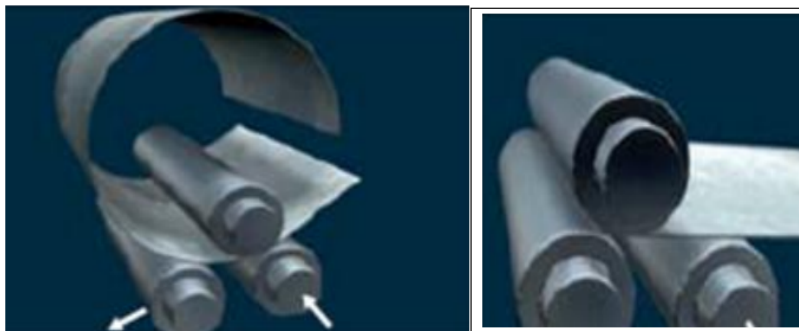

Figure 6: Rolling process

In the first stage the plate is kept between top roller and bottom rollers as shown and the top roller is given vertical displacement to get the required bend. In next stage the bottom rollers are driven using motors in forward direction

to get the roll bending of the plate. Similarly the rollers are driven in reverse direction to get better dimensional accuracy of the final product. The bent plate is then unloaded by raising the top roller.

### 2.2.3 Rebar bending machine

Mainly for bending bars and circular sections.



Figure 7: current radar bending machine

### 2.2.4 Pipe bending machine



Figure 8: Pipe bending machine



Figure 9: Existing machines

## 2.3 Problems associated with the bending machines

- They are huge hence not portable, they can be moved from one place to another once mounted.
- They are operation specific, that is to say, each type has a specific type of operation it achieves for instance, having two machines, one which can bend solid rods and the other one which can only bend hollow sectional beams.
- No height adjustments, cannot be used effectively by different operators

## 3. Methodology

The researchers visited Company X a number of times to look at the old machinery which are currently in using to identify the size of the products in order to determine the size of the machine and the dimensions of the machinery.

The researcher went to gather more information from the internet in a bid to increase the performance and productivity of the products at Tanroy Engineering. Production analysis was implemented during the course of the project to determine the products that can be obtained by using a manually operated bending machine compared to an electrically powered bending machine.

For the design, The SolidWorks 2015 software, Inventor professional and AutoCAD 2014 software were used for mechanical drawing, dimensioning and stress analysis. For material selection, tests were carried out in the mechanical laboratory. Material tests for fatigue, tensile and torsional were used to test the strength of the materials to be placed on the machine. The researcher did more studies on the existing lubricants to increase the lifespan of the machine. For the design concepts, two operations for the working of the machine were generated which are hydraulic motors and the use of gears to obtain the desired speed of rotation when bending. Firstly, hydraulic motors are considered for use. Secondly there is gear mesh system .In such a system a number of gears are put in mesh to increase or reduce the speed of rotation of the bending system. The cost of the materials is of paramount importance since it leads to the overall cost of the bending machine. Therefore, cheaper material with longer life span was chosen for the design. About three concepts were generated and from those three one was chosen as the best using the binary dominance matrix method, after the selection then follows the development of the chosen solution.

### 3.1 Specifications

Table 1: Technical specifications of the bending machine to be designed.

Motor power	2hp
Motor speed	15rpm
Bending force	2500
Top roller diameter(sheet bending)	60mm
Bottom rollers diameter sheet bending)	50mm
Top pulleys diameter(tube and pipe bending side)	195mm
Bottom pulleys (tube and pipe bending side)	195mm
weight	400kg

## 4. Results and discussion

### 4.1 Design

A number of experiments were carried out in the laboratory.



Figure 100: Bending testing machine in the mechanical lab

#### 4.1 Determination of motor 1 rating

For the tests below mild steel was used as the specimen

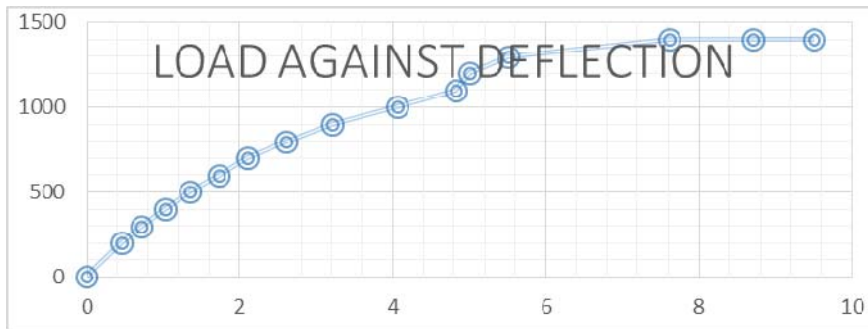

Figure 11: Graph for the circular rod 4mm thick (graph 1), dimensions – thickness 1.62mm by 1200mm by 900mm

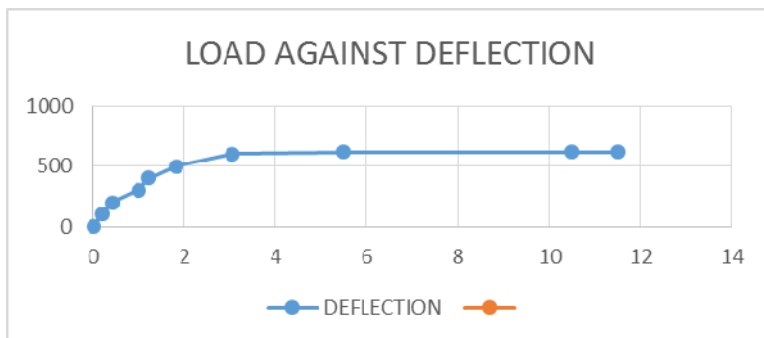

Figure 12: Graph for the hollow circular rod 20mm outside diameter and 16mm internal diameter (Graph 2)

The results of the experiment show that when a certain amount of load is applied a deflection occurs hence we have an almost linear function at the first part of the graph. When a maximum load is reached, deflection continues to occur. From the graph of the Load against deflection, the value of the maximum force to bend a metal can be

obtained. For the design a graph of the experiment on hollow circular pipe is chosen for determination of the maximum bending force because of the large amount of load needed to bend. From the graph the maximum Load =1500N. Taking into account the heat losses a high value of 2000 was chosen

Force to cause bending applied to the rollers ( $F_B$ ) =2000N

Frictional force ( $F_f$ ) =  $\mu N$

Taking  $\mu = 0.06$  and  $N = 1500$  the normal force being equal to the force to cause bending

Total Force ( $F_t$ ) = Force to cause bending + frictional force  
 $= (0.06 \times 1500) + 1500 = \underline{2090 \text{ N}}$

$r$  = radius of the rollers

Taking  $r$  to be 100mm for the radius of the pulleys

$T$  = Torque applied to the rollers

$T = Fr = 2090\text{N} \times 0.5\text{m} = \underline{1045.0\text{Nm}}$

$t$  = thickness of the sheet

$L$  = roll gap

## 4.2 Design process

### 4.2.1 Shaft under twisting moment only

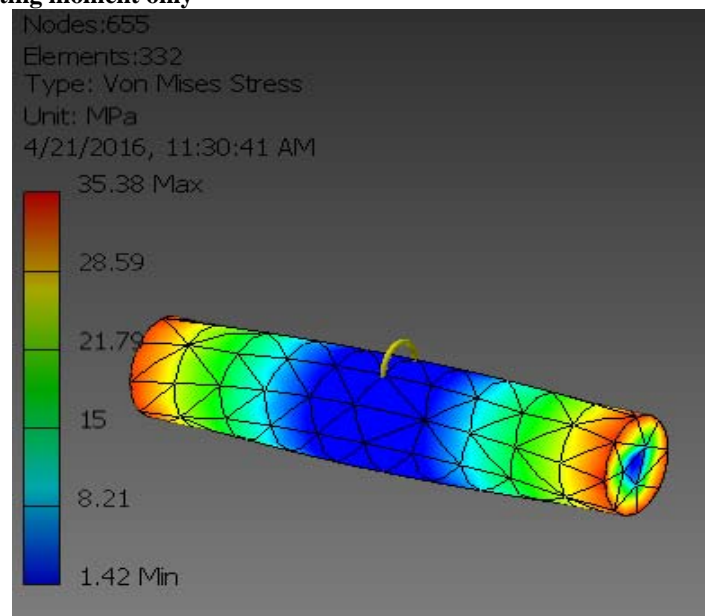

Figure 13: Shaft von Mises

Size of the shaft subjected to gradually applied load.

With little or no bending force on the shaft, the available weight is the weight of the shaft

- $K_m=0$  ,  $M=0$

Hence we remain with  $T_e = K_t \times T = 1045 \times 10^3 \text{Nmm}$  and  $M_e = K_t \times T = 1045 \times 10^3 \text{Nmm}$

We also know that equivalent twisting moment ( $T_e$ ). Taking the value of the allowable shear stress to be equal to 100 Mpa. Torque transmitted of the shaft from the motor =  $1045 \times 10^3 \text{Nmm}$

$$1045 \times 10^3 = \frac{\pi}{16} \times 100 \times d^3 \Rightarrow d = \sqrt[3]{(33221.4)} = 37.60 \text{ mm}$$

We know that the equivalent bending moment,

$$M_e = \frac{\pi}{16} \times 110 \times d^3 = 1045 \times 10^3 = \frac{\pi}{16} \times 110 \times d^3$$



$$d = 36.4 \text{ mm}$$

Taking the larger of the two values and from the standard sizes of shafts  $d = 40 \text{ mm}$  obtained from (KHURMI & GUPTA., 2005)

#### 4.2.2 Coupling connecting gearbox and the electric motor

Design of a cast iron protective type flange coupling to transmit 1640.65 W at 1000 rpm from an electric motor to the gear box the service factor may be assumed as 1.35. The following permissible stresses may be used

Shear stress for shaft bolt and key material = 40 Mpa

Crushing stress for bolt and key = 80 Mpa

Shear stress for cast iron = 8 Mpa

##### 1) Design for hub

To find the diameter, we know that torque transmitted of the shaft

$$T = \frac{P \times 60}{2\pi N} = \frac{1640.65 \times 60}{2\pi \times 1000} = 15.67 \text{ Nm}$$

Since the service factor is 1.35, therefore the maximum torque transmitted by the shaft

$$T_{\max} = 1.35 \times 15.67 = 21.15 \text{ Nm}$$

But torque transmitted by the shaft (T)

$$T = \frac{\pi}{16} \times \tau_c \times d^3$$

$$21.15 \times 10^3 = \frac{\pi}{16} \times 40 \times d^3; \quad d^3 = 2692.90; \quad d = 13.91 \text{ mm}$$

D = outer diameter of the hub;  $D = 2d = 2 \times 13.91 = 27.83 \text{ mm}$

And length of hub  $L = 1.5d = 1.5 \times 13.91 = 20.87 \text{ mm}$

- Checking for the induced shear stress for the hub which is cast iron .considering the hub as a hollow shaft maximum torque transmitted ( $T_{\max}$ )

$$21.15 \times 10^3 = \frac{\pi}{16} \times \tau_c \times \left( \frac{27.83^4 - 13.91^4}{27.83} \right); \quad \tau_c = 21.15 \times 10^3 \times \frac{16}{\pi} \times 4.948 \times 10^{-5}; = 5.3 \text{ N/mm}^2 = \underline{5.3 \text{ Mpa}}$$

Since the induced shear stress for the hub material is less than the permissible value of 8Mpa , therefore the design is safe.

##### 2) Selection of a key

Since the crushing stress of the material is twice the shear ( $\sigma_{ck} = 2 \tau_k$ ), therefore a square key may be used .

From table 3, for a shaft diameter of 12mm

Width of key = **5mm**

And thickness of key = **5mm**

But length of I is equal to length of hub

$$I = L = 20.82 \text{ mm}$$

- Checking for the induced stress in shearing, considering the key in shearing . we know that the maximum torque transmitted ( $T_{\max}$ )

$$\text{➤ } 21.15 \times 10^3 = I \times w \times \tau_k \times \frac{d}{2} = 20.82 \times 5 \times \tau_k \times \frac{13.91}{2}; \quad \tau_k = \underline{29 \text{ Mpa}}$$

- Checking for the induced stress due to crushing. we know that the maximum transmitted torque

$$(T_{\max}); \quad 21.15 \times 10^3 = I \times \frac{t}{2} \times \sigma_{ck} \times \frac{d}{2} = 20.82 \times \frac{5}{2} \times \sigma_{ck} \times \frac{13.91}{2}; \quad \sigma_{ck} = \underline{58.42 \text{ Mpa}}$$

- Since the induced shear and crushing stresses in the key are less than the permissible stresses, therefore the design for key is safe

Material : steel carbon

#### 4.2.3 Von Mises Stresses

From (Hearn, 1997, p. 180)

- $$\sigma_v = \left(\frac{207-0}{2}\right)^2 + \left(\frac{0-207}{2}\right)^2 + \left(\frac{-207-207}{2}\right)^2^{1/2} = 41,65 \text{ Mpa}$$

The design procedure has already highlighted the application of the bearing. The shaft will pass through the upper part of the swinging jaw through a bearing and also the shaft will embed in other identical bearing in the hub of a fixed support.

### 5. Assembly drawings

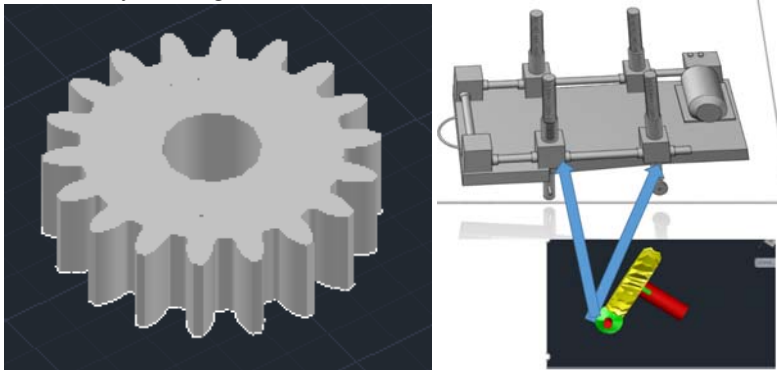

Figure 14: Spur gear and lifting mechanism

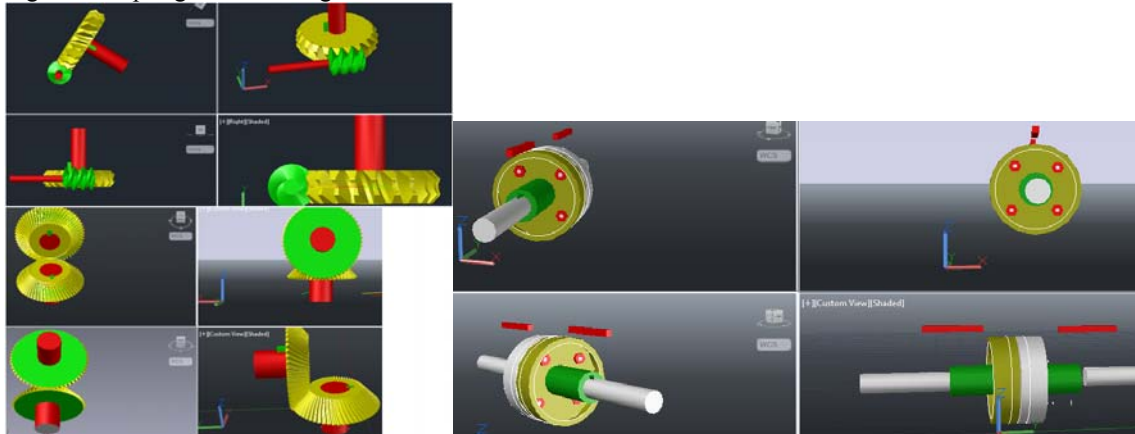

Figure 15: A bevel gear and a coupling

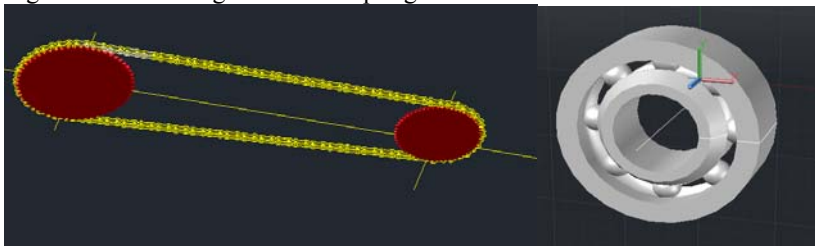

Figure 16: A chain drive and a roller contact bearing

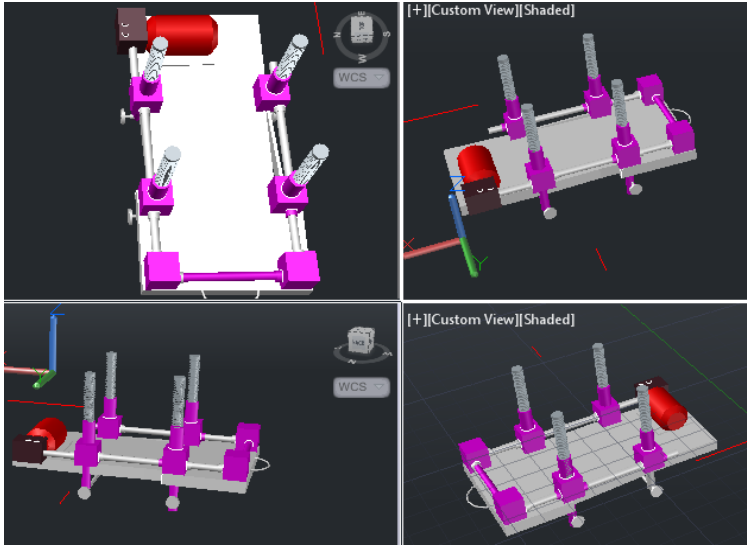

Figure 17: The bending table

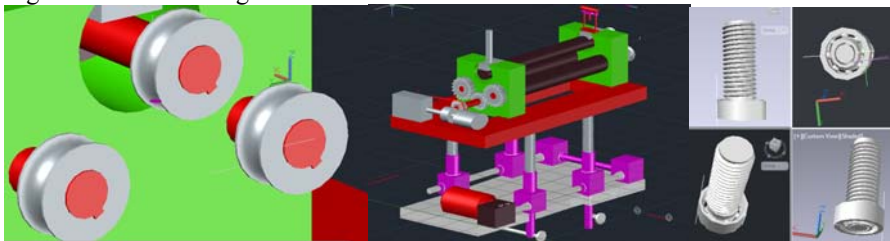

Figure 18: The pulleys, the final assembly and power screw connection to bearing

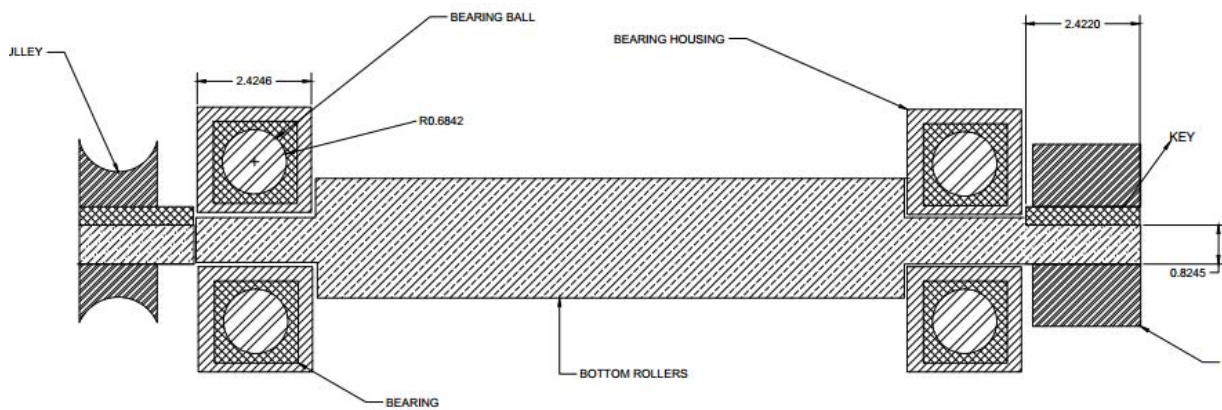

Figure 19: Machine operation

## 6. Recommendations and Conclusions

- The machine uses a manual screw to move up and down the roller, this is time consuming hence the need for a servo motor, sensors which can position the top roller properly to a required radius of the rollers.
- Two reduction systems may reduce the efficiency of the machine due to heat lose hence the need to redesign placing a single gear system between the electric motor and the roller and pulleys.
- More work has to done to increase number of operations on the machine.

- Redesign to use one electric motor reducing the cost of the machine.
- The height adjusting mechanism should be kept as low as possible for stability and prevention of falling over. when not in use or in storage the machine should be kept as low as possible, this can mean setting it on the ground and relieving the height adjusting mechanism to avoid creep on some members that are under considerable force.
- When operating the operator may stand clear of moving parts particularly the rotating disk to avoid injury and wear protective clothing in case of some heavy parts falling especially the feet which may need to be protected by safety shoes.

### 6.1 Conclusions

Design analysis of three roll pyramid type plate bending machine has been made considering a steel plate of width 80mm and thickness 1mm. Layout of the machine and the configuration is decided based on this analysis. Forces on various components are estimated. Using the standard design procedure, various components of the machine is designed and the design details are shown in respective sections. Thus we have manufactured a pyramid type plate bending machine. As compare to the manually operated sheet bending machine the power operated sheet bending machine is better. The productivity of power operated sheet bending machine is higher. The part of machine is able to handle the heavy load on machine. The time required to complete bending operation is less and the requirement of extra worker's reduced. Power operated sheet bending is less time consuming process with high productivity.

### References

1. Alibaba.com, 1999. alibaba. [Online]; Available at: <http://www.alibaba.com>, [Accessed 3 October 2015].
2. Amirul Farhan B Mohd Salih, 2010. design of a bending machine for bowlfeeder attachment. *Robotic and Automation*, iii(12), p. 24.
3. Anon., n.d. EUROPAGES. [Online]; Available at: <WWW.EUROPAGES.CO.UK>, [Accessed 24 SEPTEMBER 2015].
4. Boresi ,A.P and Schmidt ,R .J , 1993. *Advanced mechanics of materials*. 1st ed. New York: John Wiley and Sons .
5. Cook and Young, 1995. *Advanced mechanics of materials*. 1nd ed. New York: Macmillan Publishing Company.
6. Hearn, E. J., 1997. *An Introduction to the Mechanics of Elastic and*. In: *Mechanics of Materials 1*. Oxford: Butterworth-Heinemann, p. 15.
7. HERCULES, 1999. Hercules Wetzlar GMBH. [Online]; Available at: <www.hercules-wetzlar.de>, [Accessed 23 September 2015].
8. Hurst, K., 1999. *Concept Selection*. In: *Engineering Design Principles*. New York: John Wiley and Sons, pp. 53-63.
9. Jong Gye Shin, 2001. *Mechanical determination of center roller displacement in three roller bending for smoothly curved rectangular plates*. *KSME International journal*, 15(12), pp. 1655-1663.
10. Khurmi, R. & Gupta., J., 2005. *Textbook for machine design*. 2nd ed. Eurasia: Ram Nagar.
11. M K Chudasamal and H K Ra val, 2012. *Analytical model for prediction of force during three roll multipass Conical bending and the experiment verification*. *International journal of mechanical engineering and robotics research*, i(12), p. 56.
12. Magnusson ML, K. K. M., 2002. *Spine ergonomics*. *Annual Review of Biomedical Engineering*, 1(48), pp. 49-68.
13. Maher, 2000. *A systematic review of workplace interventions to prevent lower back pains*. *Australian Journal of Physiotherapy*, 1(46), pp. 259-269.
14. Strato G, 2016. *Tanroy Engineering*. [Online]; Available at: <www.tanroy.com>, [Accessed 22/02/2016 February 2016].
15. ZiedAntar and Ahmed Ktari, 2012. *Modeling and computation of the three roller bending process of steel sheets*. *Journal of mechanical science and technology*, 1(13), pp. 123-128.

**Acknowledgements**

I would like to thank the company that I worked with for data gathering.

**Biography**

**Tawanda Mushiri** is a PhD student at the University of Johannesburg in the field of fuzzy logic systems and maintenance, is a Lecturer at the University of Zimbabwe teaching Machine Dynamics, Solid Mechanics and Machine Design. His research activities and interests are in Artificial intelligence, Automation, Design and Maintenance engineering Contacted at [tawanda.mushiri@gmail.com](mailto:tawanda.mushiri@gmail.com) / [tawandamushiri123@hotmail.com](mailto:tawandamushiri123@hotmail.com)

**Definite Shumba** is a Mechanical Engineering student at the University of Zimbabwe (2016). Contacted at: [definiteshumba8@gmail.com](mailto:definiteshumba8@gmail.com)

**Charles Mbohwa** is currently a Full Professor of Sustainability Engineering and Engineering Management at the University of Johannesburg, South Africa. Contacted at [cmbohwa@uj.ac.za](mailto:cmbohwa@uj.ac.za)