

Electronic Thesis and Dissertation Repository

7-10-2017 12:00 AM

Audio Mastering as a Musical Competency

Matthew T. Shelvock
The University of Western Ontario

Supervisor
Dr. Jay Hodgson
The University of Western Ontario

Graduate Program in Music

A thesis submitted in partial fulfillment of the requirements for the degree in Doctor of
Philosophy

© Matthew T. Shelvock 2017

Follow this and additional works at: <https://ir.lib.uwo.ca/etd>



Part of the [Composition Commons](#), [Musicology Commons](#), [Music Practice Commons](#), and the [Other Music Commons](#)

Recommended Citation

Shelvock, Matthew T., "Audio Mastering as a Musical Competency" (2017). *Electronic Thesis and Dissertation Repository*. 4703.
<https://ir.lib.uwo.ca/etd/4703>

This Dissertation/Thesis is brought to you for free and open access by Scholarship@Western. It has been accepted for inclusion in Electronic Thesis and Dissertation Repository by an authorized administrator of Scholarship@Western. For more information, please contact wlsadmin@uwo.ca.

Abstract

In this dissertation, I demonstrate that audio mastering is a musical competency by elucidating the most significant, and clearly audible, facets of this competence. In fact, the mastering process impacts traditionally valued musical aspects of records, such as timbre and dynamics. By applying the emerging *creative scholarship* method used within the field of music production studies, this dissertation will aid scholars seeking to hear and understand audio mastering by elucidating its core practices as *musical* endeavours. And, in so doing, I hope to enable increased clarity and accuracy in future scholarly discussions on the topic of audio mastering, as well as the end product of the mastering process: records.

Audio mastering produces a so-called *master* of a record, that is, a finished version of a record optimized for duplication and distribution via available formats (i.e, vinyl LP, audio cassette, compact disc, mp3, wav, and so on). This musical process plays a crucial role in determining how records finally sound, and it is not, as is so often inferred in research, the sole concern of a few technicians working in isolated rooms at a record label's corporate headquarters. In fact, as Mark Cousins and Russ Hepworth-Sawyer (2013: 2) explain, nowadays “all musicians and engineers, to a lesser or greater extent, have to actively engage in the mastering process.” Thus, this dissertation clarifies the creative nature of audio mastering through an investigation of how mastering engineers *hear* records, and how they use technology to achieve the sonic goals they conceptualize.

Acknowledgements

I'd like to express gratitude to a number of folks who contributed to this project in various ways. First and foremost, I thank Dr. Jay Hodgson for mentoring over the last several years. Not only did Dr. Hodgson supervise this dissertation, he also taught me how to master records, and encouraged me to assist him with numerous chart-topping releases. Over 7 years ago he asked me to shadow and assist at Jedi Mastering, and I will remain forever grateful. Dr. Hodgson was also very encouraging in my transition from a session guitarist/music director to a producer/audio nerd. Thank you for helping me to release my first record after years of supporting other artists, and for your excellent *The Room* (2003) impressions — as well as for your insightful career and life advice.

This project would not have been possible without the suggestions provided by my second reader, Dr. Robert Toft. I am grateful for his suggestions, and his commitment to accuracy. Moreover, I have been inspired by Dr. Toft's research methods, as stated in the chapters to follow, and I am thankful for his advice and patience throughout the writing process. I took courses with Dr. Toft for approximately 8 years, and I am most appreciative of the numerous ways in which he continues to teach me.

In addition to academic mentors, I am grateful to fellow working musicians and studio personnel who have taught me over the years. In particular, I'd like to thank Skip Prokop of Lighthouse for taking me under his wing when I was a teenager. The time we spent in studios, gigging, and rehearsing motivated me to pursue a music career. I'd also like to thank producer/songwriter Josh Leo for acting as an industry *sensei*, for his professional support while I lived in Nashville, and for connecting me with numerous world-class recordists such as Steve Marcantonio and Ben Fowler.

A number of industry, production, and engineering colleagues continue to inspire me, such as Russ Hepworth-Sawyer, Richard Cleaver, Bryan Martin, Dom Dobransky, Spencer Baird, Dan Turcotte, Ray Muloin, Dan Slinger, Roberto Mendez, Steve Macleod, Al Sims, and many others. A heartfelt “thanks” to all, I continue to learn so much from each of you.

I’d also like to acknowledge a number of graduate school colleagues who have read my drafts and provided feedback. Many thanks Dave Ure, Mack Enns, and Gillian Carrabre for your insight, help, and friendship.

Last, but not least, thanks to Dr. Catherine Nolan and Audrey Yardley-Jones for providing continual administrative support. You both go above-and-beyond for graduate students at the Don Wright Faculty of Music, and I appreciate all the help you have given me over the last several years

Table of Contents

Abstract.....	i
Acknowledgements.....	ii
Table of Contents.....	iv
List of Figures.....	vi
Audio Examples*.....	vii
Introduction.....	1
Literature Review.....	2
Methodology.....	12
Chapter Overview.....	15
Chapter One.....	18
Audio Mastering:.....	18
Sonic Expertise and Musical Proficiency.....	18
An Overview of the Mastering Process.....	18
Capture.....	19
Figure 1.2.....	22
Signal Processing.....	25
Sequencing Programme Material.....	27
Formats and Delivery.....	28
Width/Depth, Noise Management, and Loudness.....	34
Establishing Stereo Presentation, <i>Width</i> , and <i>Depth</i>	34
Managing Noise.....	41
Loudness.....	53
Loudness Wars.....	60
Evaluating Records: Ear Training, and Sonic Orientation.....	68
Assessing Records.....	71
Ear Training and Listening Focus.....	72
Benchmarking and <i>Quality</i>	75
Chapter Two.....	81
Dynamic Configuration.....	81
Compressor Controls.....	82
Types of Compressors.....	86
Optical.....	86
Variable-MU.....	89
FET.....	91
VCA.....	93
Digital Compression.....	95
Compression Methods and Approaches.....	98
Light Compression.....	98
Medium Compression.....	100
Heavy Compression.....	102
Peak Limiting/Attenuation.....	104
Parallel Compression.....	105
Multiple Stages of DRC.....	109

Using the Multiband Compressor	110
Other Methods for Adjusting Dynamic Range	114
DRC and Stereo Imaging: Mid/Side Processing and Dynamic Reconfiguration.....	115
Dynamic Expansion	117
Sidechain Filtering	119
Hypercompression as an Aesthetic Tool.....	120
Chapter Three.....	123
Designing Timbre	123
Equalizers, Frequency Ranges, and Achieving <i>Balance</i>	128
Shaping Fundamental Frequency and Upper Harmonics via EQ	137
High-Pass and Low-Pass Filters	140
Shelving Filters	141
Parametric Equalization and Peaking Filters	141
Graphic EQ	142
Dimensional Timbre: Unlinked (L +R) and Mid/Side Equalization.....	143
Timbral Colouration: Distortion, Nonlinearity, Enhancement, and Specialized EQs.....	145
Analog Colouration and “Warmth”	146
Circuit Components and Non-Linearity.....	148
Extreme Colouration: Distortion, Saturation, and Clipping.....	155
Exciters, Enhancers, and Maximizers	158
Adaptive Timbral Modification: Multiband Compression and Dynamic EQ.....	161
Interpreting and Modifying Timbre: The Role of Phenomenology in Timbral Design.....	167
Chapter Four	179
A Case Study in Audio Mastering	179
Initial Assessment	180
Capture.....	183
Signal Processing	184
Sequencing.....	194
Formatting/Delivery.....	196
Conclusion	199
WORKS CITED AND CONSULTED.....	205

List of Figures

Figure 1.1	19
Figure 1.2	22
Figure 1.3	32
Figure 1.4	36
Figure 1.5	59
Figure 1.6	64
Figure 1.7	64
Figure 2.1.1 Logic X Compressor.....	85
Figure 2.1.2: Optical Compressor Signal Flow.....	87
Figure 2.1.3: Teletronix LA-2A.....	88
Figure 2.1.4: Vari-Mu Compressor: Signal Flow Diagram	89
Figure 2.1.5: Fairchild 670 Variable-MU Compressor.....	90
Figure 2.1.6: FET Compressor: Basic Signal Flow	92
Figure 2.1.7:FET Compression: The 1176.....	93
Figure 2.1.8: VCA Compressor Signal Flow.....	94
Figure 2.1.9: VCA Compression, The API 2500.....	95
Figure 2.2: Multiband Compressor Crossovers	112
Figure 3.1.1: Equalizer Example, Logic X Native EQ	129
Figure 3.2.1: Triode Diagram	150
Figure 3.2.2: Beam Tetrode Diagram	151
Figure 3.2.3: Pentode Diagram	152
Figure 3.3.1: Tape Saturation Emulator, iZotope Ozone 7.....	156
Figure 3.3.2: BBE Sonic Maximizer (Rackmount).....	161
Figure 3.4.1: “Kung Fu” by Bauuer (2016)	169
Figure 3.4.2: “Gatorade” by Yung Lean (2013)	170
Figure 3.4.3: “Bussin’ Jugs” by Gucci Mane (2012).....	170
Figure 3.4.4: “Reflektor” by the Arcade Fire.....	171
Figure 3.4.5: “Somebody That I Used to Know” by Gotye (2011)	172
Figure 3.4.6 :“Ho Hey” by The Lumineers (2012).....	172
Figure 4.1.1	181
Figure 4.1.2	182
Figure 4.2.1	183
Figure 4.3.1	185
Figure 4.3.2	188
Figure 4.3.3	190
Figure 4.3.4	192
Figure 4.3.5	193
Figure 4.4.1	195
Figure 4.4.2.....	198

Audio Examples*

***Important Note:**

A significant portion of my research is conveyed via audio demonstration. Readers must listen to these examples in order to understand the musical and sonic consequences of audio mastering. I uploaded all demonstration audio to <https://soundcloud.com/matt-shelvock/sets/dissertation-audio-mastering-as-a-musical-competency>

Introduction

Audio mastering refers to the process of finalizing records for release. Mastering engineers shape the final timbral and dynamic qualities of records, and they also prepare records for distribution. In this dissertation, I demonstrate that audio mastering is a musical competency by elucidating the most significant, and clearly audible, facets of this competence. In fact, the mastering process impacts traditionally valued musical aspects of records, such as timbre and dynamics. By applying the emerging *creative scholarship* method prized within the field known as music production studies, this dissertation will aid scholars seeking to hear and understand audio mastering by elucidating its core practices as *musical* endeavours. And, in so doing, I hope to enable increased clarity and accuracy in future scholarly discussions on the topic of audio mastering, as well as the end product of the mastering process: records.¹

Audio mastering produces a so-called *master* of a record, that is, a finished version of a record optimized for duplication and distribution via available formats (i.e., vinyl LP, audio cassette, compact disc, mp3, wav, and so on). This musical process plays a crucial role in determining how records finally sound, and it is not, as is so often inferred in research, the sole concern of a few technicians working in isolated rooms at a record label's corporate headquarters. In fact, as Mark Cousins and Russ Hepworth-Sawyer (2013: 2) explain, nowadays “all musicians and engineers, to a lesser or greater extent, have to actively engage in the mastering process.”

Every record is mastered, even if it doesn't pass through an independent mastering phase (all records feature a final “master” dynamic and spectral balance, and, as such, every

¹ I use the word *record* to describe all types of recordings, from vinyl LP to digital streaming .

record is mastered). All musical contributions to a record may be modified by a mastering engineer before duplication and distribution occur. In fact, given the present ubiquity of records as an avenue for experiencing music, I contend that audio mastering has become a crucial musical competency in general. However, scholars rarely address the process in any substantive way. Moreover, when academicians do address it, they typically treat mastering as a technical afterthought in the record production process, that is, as a kind of data processing rather than anything overtly artistic. Some commentators have even avoided addressing mastering by arguing that it is only used in particular genres, when it is practiced equally — though perhaps to different ends — to make records of every musical stripe, from so-called classical to trap music. It is my ultimate hope that, through this dissertation, these misunderstandings are finally laid to rest.

Literature Review

This dissertation builds upon my previous work on the topic of audio mastering (2012). Apart from my MA thesis, and this dissertation, a limited number of scholarly sources discuss audio mastering in a substantive way.² In order to construct this dissertation's methodology (as discussed below), I consulted the few available studies on audio mastering from the field known as *music production studies* (MPS). In addition, I also incorporate literature from other areas of MPS, as scholars in this field analyze the creative methods that establish records in general.³ I also consulted sources from other fields of musical analysis which adopt

² Available scholarship on audio mastering is limited to the following: Cousins & Hodgson (2013), Golding & Hepworth-Sawyer (2011), Hepworth-Sawyer & Hodgson (forthcoming), Hodgson (2010), Katz (2007), Nardi (2014), Owsinski (2008), and Shelvock (2012)

³ For example, please see: Ballou (2015); Corbett (2014); Corey (2016); Hepworth-Sawyer, Hodgson, Patterson & Toulson (2014, 2016); Hepworth-Sawyer & Hodgson (2017); Hodgson (2010, 2014); Izhaki (2008); Kadis (2012); King (2017); Langford (2013); Lellis (2013); Moylan (2006); Mynett (2017); Owsinski (2017); Rumsey & McCormick (2014); Shelvock (2011, 2012a, 2012b, 2014, 2015, 2017, forthcoming); Senior (2014); White (2014)

the *creative scholarship* model, such as popular music studies and music theory (Toft 2010; Doğantan-Dack 2015).

The book *The Art of Record Production* (2012) announces MPS as a dedicated area of inquiry. Authors Simon Zagorski and Simon Frith (2012: back cover) describe the necessity of this field, stating:

The playback of recordings is the primary means of experiencing music in contemporary society, and in recent years 'classical' musicologists and popular music theorists have begun to examine the ways in which the production of recordings affects not just the sound of the final product but also musical aesthetics more generally. Record production can, indeed, be treated as part of the creative process of composition. At the same time, training in the use of these forms of technology has moved from an apprentice-based system into university education. Musical education and music research are thus intersecting to produce a new academic field: the history and analysis of the production of recorded music.

Thus, MPS maintains an analytical focus on records and record-making techniques. As the most ubiquitous form of musical engagement in the world today, music scholars require literature that directly engages with the creation of these artifacts. This is precisely what MPS scholars seek to accomplish. Elsewhere, authors Russ Hepworth-Sawyer and Jay Hodgson (2017: xii-xiii) describe the analytic goals of MPS as follows:

The production process is broad, to be sure, but it is rationalized into numerous component procedures, each of which, while holistically related, nonetheless requires its own specialized expertise(s). And this is true whether that expertise is located in a team of people or in one single individual, as the 'project' paradigm would demand. Every record production, regardless of genre and circumstance, requires at least the following procedures: pre-production (conception vis-à-vis available technology), engineering (recording and/ or sequencing), mixing and mastering (even if only bouncing without any further processing), and distribution of some sort (lest the recording remains inaudible data). While record producers are indeed responsible for overseeing a project through each of these component phases—and, thus, while it may seem fair to simply refer to the totality of these phases as 'record production'—every phase has its own unique aesthetic priorities and requirements, and each of these reacts back on, and (re)shapes, the musical object being produced in turn. Ultimately, it is uncovering and understanding the broader musical ramifications of these priorities and biases that comprises this [field's] primary analytic concern.

As a result of this direct focus on record-making techniques, the MPS paradigm generally attracts scholars who possess the production skills they critique. In fact, this

subfield favours research methodologies rooted in *creative scholarship*. Indeed, one cannot substantively comment on the musical reasons for using an equalizer (EQ) during audio mastering without also knowing how to master records, for example. While operating such a device is a simple task, to analyze the application of EQ by mastering engineers also requires deeper insight regarding the aesthetic goals of mastering, and how mastering engineers *hear* records. Simply put, in order to elucidate the *musical* reasons to apply any production technique, researchers must also have experience in applying this technique towards a *musical* goal. Thus, the core method I used to write this dissertation involved learning how to master records. In so doing, I learned how to apply the most common mastering techniques to actual records.

While MPS scholars value *creative scholarship*, they also publish books and articles such as those cited above. This emerging tradition bridges the gap between professional trade literature describing production tools, and the scholarly assessment of these tools. In all available MPS scholarship, the boundary between these two worlds effectively collapses. An example of such an approach is found in Jay Hodgson's *Understanding Records* (2010). His goal in writing this foundational book is to connect recording techniques to musical practice, as he states (2010: x):

The musical techniques I survey in [*Understanding Records*] are simply those that recur most often on modern pop records. In so doing, they comprise a fundamental musical lexicon, or a basic musical vocabulary. Aside from a few pioneering exceptions, though, this lexicon remains notably absent from professional research on popular music history and practice. Surprisingly, these musical terms are also absent from the vast majority of audio-engineering textbooks currently on the market, which usually only sketch the technical details of Recording Practice without explicitly referencing any of the aesthetic programs that recordists deploy their musical practice to service.

Hodgson goes on to demonstrate how numerous tracking, signal processing, mixing, and mastering techniques are inherently musical practices. As such, his work is a model for MPS research, such as this dissertation.

However, MPS is not the only area of musical study that encourages the training of creative scholars. Elsewhere, music theory researchers argue that superficial distinctions between *practice* and *theory* may be a detriment to scholars (Doğantan-Dack 2015: 1-10). Nicholas Cook (2015: 12), for example, makes this argument in “Performing Research: Some Institutional Perspectives.” He states:

Terms like ‘practice-based research’ or ‘practice-led research’ suggest that practice and research are basically different, perhaps even mutually exclusive things, whereas — as will become clear — the foundation of current institutional thinking is that practice can actually *be* research. That is why [...] I refer to ‘practice *as* research.’ But there is a more fundamental problem. The point of the term ‘practice’ is to make a distinction from something else, but what is that something? An obvious answer would be theory. But theory and practice do not divide up so neatly: as Fiona Candlin complains, attempts to draw distinctions between academic work and artistic practice ignore “both the practical elements of theoretical writing and the theoretical aspects of art practice” (2000, p. 100). In academic contexts such as PhD regulations, the distinction tends to be between practice and text, but this is no more satisfactory. As Candlin also says, academic writing is itself a practice: it is ‘not simply apparent and clear but forms an ingrained set of assumptions that underpin stylistic rules to the point where they have become naturalised’ (2000, p.100). That is, it has its own conventions and criteria of good practice. And the confusion is compounded when, as frequently in both academic and bureaucratic circles, the word ‘practice’ is coupled with ‘creative:’ whether creativity is defined in terms of bisociation, flow, or paradigm change, it would be absurd to maintain that academic writing cannot embody it. In this way the idea of ‘practice,’ creative or otherwise, is so ill-defined as to obscure what might be more meaningful distinctions — for example, those between practices, such as academic writing, that are self documenting and those that are not, or between those that involve real-time action and those that do not.

Cook clarifies that academic institutions now willingly accept creative practice as research. In keeping with the tradition he describes, I began my own mastering practice to undertake this dissertation. To this end, I provide a case study of a typical mastering session in chapter 4. However, the completion of chapters 1-3 also required extensive training in the practice of audio mastering, as I use numerous audio examples and visual illustrations to elucidate audio mastering in a musical context. The audio and visual examples I provide in this dissertation aid readers in understanding how mastering engineers *conceptualize* and *finalize* a record’s sonic properties, and this task would be impossible without also knowing how to master records myself.

While the quotation I provide above comes from music theory literature (Cook 2015: 12), a practice-centered research method also informs prominent scholarship on songwriting for popular records. Researcher Robert Toft (2010: viii) adopts a methodology focused on concrete musical practices in *Hits and Misses: Crafting Top 40 Singles, 1963-1971*. On his chosen methodology, he offers:

Hits and Misses investigates the methods by which recordists (songwriters, arrangers, band members, producers, and engineers) impart their ideas to audiences.

As a writer on music, I have always contextualized my work within the culture that produced the chosen texts for study, and in my research on popular music, I prefer to place the musical activities of pop/rock artists in a framework that resonates with popular musicians. Consequently, the methodologies employed in this book are rooted not in cultural studies, semiotics, poststructuralism, Schenkerian techniques, psychology, or sociology but in close readings of texts that, to paraphrase Theodore Gracyk (1996: xiv), square with the views of musicians themselves. In fact, [numerous] writers [...] argue that musical organization must be taken seriously, precisely because artists, the music industry, and listeners take it seriously.

Thus, Toft's book elucidates musical connections between songwriting and recording by maintaining a direct focus on these practices, and by deliberately leaving out numerous non-related methods. Although other analytical tools exist, such as semiotics, poststructuralism, Schenkerian analysis, and psychology, Toft explains that these methods have little to do with the concerns of actual musical practitioners. And, as a result, these approaches do not apply when adopting a practice-centered analytical method. I model my work after literature such as Toft's by allowing the aesthetic priorities of mastering engineers (and recordists) to direct my research.

Elsewhere, Mark Marrington (2016: 267-77) offers a similar perspective to Robert Toft on the topic of teaching popular songwriting in an academic context. He argues that educators must possess songwriting skills in order to teach songwriting. He also advocates for the inclusion of professional songwriters within academic faculties (which is becoming more prevalent under the MPS paradigm):

Turning to the pedagogical context, a principal challenge for the songwriting teacher is to translate the songwriter's domain, as it exists in the world of practice, into terms that can be handled by educational constructs. The obvious strategy is to reflect the movement of the marketplace, although this brings the particular difficulty of reconciling the rapidly changing commercial landscape with the need to provide stable curricula. Educators, if they are to communicate their ideas effectively, need to acquire a certain amount of perspective on what has taken place in the domain over a particular time period and those more comfortable with the practices of their own era may either not wish to incorporate current trends into their teaching or may find it difficult to articulate these in terms of well-digested curriculum content. One way to address this issue is to involve commercially proven songwriters in the teaching team, who will be able to make students aware of what is happening on the ground as well as effectively judge what is produced relative to the marketplace. If this is not the case, then it follows that programmes at least ought to be designed to be responsive to a range of marketplace positions, which could be facilitated for example, by incorporating student-led contributions.

There is of course no obligation in the educational context to gear the teaching of songwriting exclusively towards what is happening in the commercial arena. In this author's experience of teaching at a UK Higher Education establishment, for example, songwriting tuition was delivered in the context of a Popular Music Studies degree curriculum. While by no means eschewing current trends, the course placed emphasis on historical and musicological approaches (mirroring to a certain extent the older Western art music curriculum model), which students were expected to acknowledge in their creative practice. The point was to develop a broad appreciation of the discipline and a critical approach to evaluating one's own work. Students, having acquired such a perspective, were often inclined to take a more exploratory attitude in their songwriting and question the value of simply reproducing the latest commercially proven tropes.

It is apparent in the recent pedagogical literature that academics have sought a middle ground enabling them to encompass a wide range of perspectives on the songwriting discipline within the curriculum, while at the same time retaining secure criteria for valuing an individual contribution. Bennett, for example, argues that students' creative work should be judged in relation to what he calls the 'constraints' of a recognisable popular song domain (Csikszentmihalyi is implied). The student is required to demonstrate domain immersion, with the success of the song being considered with reference to how well certain constraints have been observed. To facilitate this, song analysis aids the student in determining the 'statistical norms' of the chosen domain – in other words, those elements that are commonly found within it at a given moment (for example, a particular song structure, a regularly used chord progression, the recurrence of certain genre-specific lyrical subject matter and so on). Such an approach, which is akin to pastiche-work, certainly has value as a means of building a strong technical foundation, as well as facilitating the assessment of songs due to the clear criteria involved.

Indeed, as Marrington suggests, educators and researchers must turn their attention to the *domain* of popular songwriting — which can take many forms — in order to effectively engage with this creative practice.

Although research by Cook, Toft, and Marrington demonstrates that *creative scholarship* is currently gaining momentum in diverse musical disciplines, other academic fields already place a high value on practice-centered research. A.D. Carson's dissertation provides a recent example of such a project. Carson recently submitted a rap album in order to earn his PhD in "Rhetorics, Communication, and Information Design" at Clemson University in South Carolina (*Owning my Masters: The Rhetorics of Rhymes and Revolutions*, 2017). This record/dissertation has gone *viral* online, and has been featured on WYFF 4 News (South Carolina). His final dissertation is provided on a webpage, where he shares his methodology as follows:⁴

My process of composing the mixtapes from which "Owning My Masters" is composed each began with songs, which are reflective of my particular experience in the moments they were composed. Those experiences translated into rhymes, poems, or instrumental musics.

The matching of lyrics to the proper instrumental or instrumentals to proper lyrics or the writing of both together are unique to each piece of the larger composition. I have been fortunate to sustain relationships with collaborators, particularly Truth and Preme, who produce instrumental music with and for me to create the mixtap/e/ssays I've compiled since arriving at Clemson.

The recording process for each song varies just a bit, but each session has common elements. I used Cool Edit Pro/Adobe Audition for recording and editing all vocals. I alternated between two different condenser microphones. The difference is usually a matter of where I'm recording more than what I'm recording [I had to record on my laptop when I was in Saas-Fee, Switzerland, which was an entirely different process than recording at home because of adjustments to the room and using a portable setup]. Wherever I'm recording, levels are adjusted for the tone and volume of the track the music [if there is music used; often, when I'm recording a piece of poetry I record the vocals first, and then the music is composed around/with the words pre-existing as a sound file, as was the case with "See The Stripes"]. After vocals and music are recorded, the mixing process can be ongoing for as long as I'm unsatisfied with the sound. Normally I try to get volume levels suitable for listening outside of the computer/headphones, and then I make a version of the pre-mixed song to listen to through my phone and in my car as well as aloud through the system in my recording room. When I'm satisfied with a mix I tag the song as "[Finished]" for my files and then save it on both an internal and external drive and save the individual tracks in the computer in case I need to make adjustments later.

⁴ <http://phd.aydeethegreat.com/>

In the above quotation, Carson describes the methods he used to record his creative dissertation. The submission did not include a traditional text document, and he instead opted to provide a website that briefly describes the record, and his reasons for completing it. Interestingly, although this dissertation was intended for another field, it also fits the model of MPS research.

Carson's research method also supports Mark Marrington's (2017: 85) assertion that digital audio workstations (DAWs) act as instruments in many contemporary songwriting contexts. He states:

First, it is important to be aware that all DAWs are mediating structures—that is, they each have their own properties which influence how they may be used by the songwriter and these are often bound up with particular forms of media used for music creation in the past, ranging from the score to the sampler. Theoretically, it should be possible for a songwriter to employ any DAW effectively provided they are prepared to learn to recognize these characteristics and negotiate the tool for their own purposes. I have also drawn a parallel between the DAW and traditional instruments which have been previously associated with songwriting practice, suggesting that the DAW ought to be considered an instrument in its own right, whose idiosyncrasies need to be mastered if it is to be used effectively in the heat of the moment. Ultimately, how the DAW is used in songwriting will be determined by the place it holds in the process. One might, for example, exploit a particular DAW paradigm and allow this to condition the character of the music that emerges at an early stage. This was illustrated by the loop trigger model, a dominant characteristic of platforms such as Ableton Live, which has appealed to songwriters who use the DAW as a vehicle for on the fly experimentation. Alternatively, one might view the DAW as a means of elaborating “offline” musical ideas that have either been pre-recorded or pre-programmed. Here it is a question of the songwriter's imagination in employing the DAW's MIDI and audio editing facilities, signal processing tools and effects to expand upon the song's basic material.

Thus, the use of a DAW in the songwriting context Marrington describes can be characterized as a distinct musical competency. Since music production practice is always a variegated process, other DAW-based methods such as tracking, mixing, and mastering also represent distinct musical competencies. Indeed, these processes (songwriting, tracking, mixing, and mastering) are always rationalized into distinct stages by music production practitioners, and require separate theorization by music scholars as a result (Hepworth-Sawyer & Hodgson 2017: xii-xiii).

Prior to MPS, and the now ubiquitous *creative scholarship* paradigm described above, the foundation for a “musicology of record production” was most famously popularized by Albin Zak (2001). Zak’s seminal monograph, *The Poetics of Rock: Cutting Tracks, Making Records* (2001), established beyond question that musicologists have much to learn from the art of record production. Most broadly, Zak uses his book to identify and elucidate five crucial elements of a record, each of which can easily sustain extended musicological scrutiny and analysis: [i] musical performance, [ii] timbre, [iii] echo, [iv] ambience, and [v] texture (2001: 49).

Each of the five musical elements Zak identifies falls within the purview of various recordist agencies — these include the audio engineer, the mix engineer, and the mastering engineer, instead of the performers they record (Zak 2001: 107). Zak explores the philosophical ramifications of this creative input in a chapter entitled “Tracking and Mixing,” where he identifies four textural dimensions that exist within the sonic space of a recorded musical communication (2001: 144):

Of these four dimensions, three are synchronic: the stereo soundstage (width), the configuration of the frequency spectrum (height), and the combination of elements that account for relations of prominence (depth). The fourth dimension is the progression of events, the narrative or montage.

These four dimensions comprise the overall *poetic* design of the recording — an artifact that can only exist as a result of tracking methods, stereo manipulation, spectral processing, emphatic or obfuscating signal processing techniques, and editing/arranging methods.⁵ To support this four-dimensional model, Zak invokes none other than George Massenburg (Ballou 1991: 1158; in Zak 2001: 144):

⁵ Here I borrow Zak’s use of the word *poetic*: “The term “poetics,” then, came to include both compositional principles and aesthetic beliefs, as in, for example, Bernard Germain Lacépède’s opera treatise, *La poétique de la musique* (1785).” (Zak 2001: xv)

I mix like I'm decorating a four-dimensional "space." Starting with some essential structural elements, I craft artifact and gesture, all of which say something about themselves and often refer to other elements in the "space": shaking hands with (or, perhaps conflicting with) other elements and usually supporting, flattering, or teasing the focal point – the center, the vocal.

Zak and Massenburg maintain that recordist input should be described not as a *support* for a musical performance but as a collection of musically communicative methods that together form the poetic design of records (Hodgson 2010: x).

However, a key methodological distinction differentiates available musicological commentary on record production and research from the field of MPS. Musicologists, such as Zak, often use records as *evidence* of record production, whereas MPS researchers analyze record-making techniques *per se* (Hodgson 2010; Frith & Zagorski-Thomas 2012). And, while records occasionally provide evidence of standard production techniques in the MPS paradigm, these studies maintain direct focus on commonly used production techniques. In other words, MPS scholarship focuses on the *inputs* of record creation rather than only the *outputs*, as many books and articles do before 2012.⁶

MPS does not yet boast a large collection of literature because it is an emerging field (Frith & Zagorski-Thomas 2012). However, available MPS research was thoroughly consulted for this dissertation. As one of the field's early contributing scholars, I hope that this dissertation will demonstrate the importance of MPS to analyzing records and record-making (2011, 2012a, 2012b, 2014, 2016, 2017, forthcoming). Moreover, I hope that the methodology I discuss below further establishes the *creative scholar* approach for future academics.

⁶ Some books and articles written before 2012 also fit the MPS paradigm. Examples include Hepworth-Sawyer (2009, 2011), Hodgson (2010, 2011), Izhaki (2008), Katz (2007), and others cited throughout this dissertation's main chapters. However, this field is not concretely defined until 2012 (Frith & Zagorski-Thomas).

Methodology

The purpose of this dissertation is to demonstrate audio mastering as a musical competence. I do this through a series of explanations, audio examples, and illustrations of the core practices associated with audio mastering. However, I do not simply describe these practices. Instead, I elucidate the musical ends to which records require audio mastering before they are considered *complete*.

An integral component of this dissertation's methodology includes the consideration of techniques used by those who master records professionally. I collected this information from published interviews with various mastering engineers. However, readers should not misunderstand this as an appeal to the fame or authority of the engineers discussed throughout this dissertation (i.e., *argumentum ad verecundiam*).⁷ Instead, available books and articles on audio mastering typically interview engineers who have worked on more commonly heard releases. In addition, it would be misleading to base my entire discussion of audio mastering on the perspectives of recordists whose work is not readily available, or heard by few. I thus consider the perspectives of engineers whose work has been *peer-reviewed*, as it were, by the recording industry (e.g., artists, engineers, producers, label executives of all types, distributors, and listeners/consumers), above those working in relative isolation.

In addition to considering available interviews with mastering engineers, I used a practice-centered research method in this dissertation. That is to say, I deepened my expertise in mastering records as an integral component of my programme of study. In fact, had I not

⁷ And, even so, few mastering engineers can be said to have achieved any level of *fame*. Audio mastering, after all, is often called the *dark art* of music production (Golding & Hepworth-Sawyer 2011: 241).

accomplished this, I would have far less of a substantial nature to contribute to existing scholarly discussions of audio mastering.⁸ However, while a practice-centered methodology informs this dissertation's fundamental approach, I also frequently reference the small body of existing literature on the topic of audio mastering.⁹

My career experiences as a studio session player and artist motivated me to embark upon a study of audio mastering. After years of working with award winning personnel (Juno, Grammy, RIAA) in studios around the world, I remained unsure of what mastering engineers actually *did* to finalize records. And, to my surprise, many of my professional peers also knew little about audio mastering. In fact, it is often referred to as a *dark art* (Golding & Hepworth-Sawyer 2011: 241). However, I could hear the aesthetic *results* of audio mastering, and I set out to learn how mastering engineers carried out their work.

In order to undertake an MA thesis on audio mastering, I began training with Dr. Jay Hodgson of Jedi Mastering and MOTTOSound 7 years ago. As an assistant engineer, I worked on several award winning, and chart-topping (Beatport) releases with Dr. Hodgson. The most celebrated of these records is Concubine's 2016 release, which was nominated for a Juno award. I have also developed my own audio mastering practice, and I regularly master records for compensation. For example, some artists I have recently worked with include Scott Brunelle, Stacy Zegers, CCMA-nominated group Runaway Angel, and a project featuring musicians from the Crash Test Dummies (Checkered Eye).¹⁰ I have also mastered

⁸ A few scholars have discussed audio mastering to date, such as Cousins & Hepworth-Sawyer (2013), Hodgson (2010), Katz (2007), Nardi (2014), Owsinski (2008) and Shelvock (2012). In order to productively contribute to broader ongoing discussions of audio mastering in MPS such as these, I learned to master audio to complete this dissertation.

⁹ Cousins & Hodgson (2013), Golding & Hepworth-Sawyer (2011), Hepworth-Sawyer & Hodgson (forthcoming), Hodgson (2010), Katz (2007), Nardi (2014), Owsinski (2008), and Shelvock (2012)

¹⁰ Runaway Angel — <http://www.runawayangelmusic.com/>; Scott Brunelle — <https://scottbrunelle.bandcamp.com/>; Checkered Eye — <http://www.checkeredeye.com/>; Stacey Zegers — <http://www.musicsolutions.com/artists/stacey-zegers/>

my own commercially released work, which is available on Spotify, Apple Music, Amazon, and others under the moniker *kingmobb*.¹¹

I began releasing music under this pseudonym as a research project within the *creative scholarship* paradigm. Some of this music is commercially licensed, such as tracks used in ads by *Plant Matter Kitchen* and *The Marq*. This creative research culminated in an article entitled “Groove and the Grid: Mixing Contemporary Hip Hop,” where I elucidate mixing practices valued on hip hop records. The article is featured within a collected anthology published by Routledge and Focal Press called *Perspectives on Music Production: Mixing Music* (2017: 170-187). I am also contributing an article on hip hop production based on my creative practice to a forthcoming *Perspectives on Music Production* anthology (expected 2018). In order to elucidate hip hop’s most valued mixing and production procedures in my published work, I have composed, recorded, and mixed numerous hip hop instrumentals (e.g., *Summoner*, 2017). I also use the music I produce to demonstrate mixing and production techniques at conferences, such as *Innovation in Music* (Anglia-Ruskin University, Cambridge, UK, 2015).

In addition, I use some of my commercially released music as a case study for this dissertation. Chapter 4 provides readers with details on how my record *Summoner* (2017) was mastered. Audio mastering, like other forms of audio engineering, is a highly individualized affair. In fact, provided with the same tools and equipment, it is unlikely that two engineers would master a record in exactly the same way. Yet, any decision made at a mastering desk is constrained by available technologies.¹² I elucidate these technologies, as well as their

¹¹ <https://www.cdbaby.com/cd/kingmobb2>

¹² While the aesthetic output of audio mastering is not wholly *technologically determined*, audio mastering is a technological process whereby records produced via one set of technological tools are conditioned by another set, in order to permit playback on yet another piece of consumer technology. Thus, no account of audio mastering can ignore the role that technology plays. All decisions made during audio mastering are constrained by available recording technologies, mixing technologies, mastering technologies, and consumer playback technologies. As a result, I refer to the actions of mastering engineers as *technologically constrained*.

musical applications, in chapters 1-3. In chapter 4, I provide the aforementioned case study detailing an actual mastering session. This case study provides a musical context for the mastering techniques discussed in chapters 1-3.

Chapter Overview

Chapter 1 begins with an overview of the mastering process. All mastering sessions involve distinct capture, signal processing, sequencing, and delivery stages, and I explain each of these tasks in Chapter 1. I also survey the audible aspects of recorded communications that mastering engineers address. This includes an analysis of how mastering engineers account for a record's finalized dynamic contour and loudness levels; timbral configuration; stereo distribution; width/depth characteristics; and noise characteristics. However, dynamics and timbre are revisited in more detail in Chapters 2 and 3 respectively, after I discuss how mastering engineers consider these parameters in a broad sense.

Each of the parameters described above are evaluated and modified by mastering engineers. To the uninitiated, some of these properties of records may seem more like technical jargon than areas requiring creative attention. However, this is simply not the case. For example, records from various genres adhere to different expectations regarding the audibility of extraneous noise. Thus, mastering engineers apply contrasting noise management strategies based on a record's intended distribution market.¹³ Indeed, a classical record typically demonstrates less noise than an indie rock or hip hop record. In fact, both indie and hip hop records often value noise as an essential aesthetic property (Shelvock 2017: 175).¹⁴ However, general noise levels for both types of records is evaluated, and adjusted, by

¹³ By *noise*, I refer to clicks, pops, hiss, and distortion (Katz 2007: 139-40).

¹⁴ Many indie and hip hop records include noise on their records as a cherished feature. I direct readers towards Kendrick Lamar's Grammy-winning album *Good Kid M.A.A.D City* (2012) as an example.

mastering engineers. It is up to the mastering engineer to know when a record's noise characteristics are desirable or undesirable, based on the genre of the record receiving attention.

After discussing how mastering engineers account for the sonic parameters discussed above, I proceed to describe the evaluative strategies engineers use to assess the records they work on. Like other musical competencies, audio mastering requires aural training in order for effective execution to occur. However, for mastering engineers, this aural training develops a specific approach to *hearing* records, distinct from how other recordists *hear* records. This chapter continues by delineating the perspectives of recordists of all types, who unanimously agree that mastering engineers are hired on the basis of their aural competency. Yet this competence is less concerned with *accuracy* than it is with musical *aesthetic*. While celebrated mastering engineers certainly possess remarkable aural precision, their work is inherently creative. Thus, I describe the subjective process of mastering records in the first chapter.

In Chapter 2, I elucidate the use of dynamic range compression techniques in audio mastering. Mastering engineers use different compressor types, circuit topologies, and settings to achieve diverse aesthetic goals. As a result, I analyze numerous musical applications for dynamic range compression (DRC) in this chapter. I also provide audio examples that demonstrate the application of DRC techniques to actual music. In so doing, readers can learn to hear and understand which applications of DRC pertain to audio mastering.

In Chapter 3, I analyze the techniques that mastering engineers use to finalize timbre on records. I also supply numerous audio examples throughout this chapter to assist readers in hearing the various ways these methods are applied to music. Naturally, some readers may find my use of the term *timbre* peculiar. This is because musicians often discuss timbre as it

pertains to individual instruments, such as the timbre of a saxophone or snare drum. However, upon playback, records can only produce a singular timbre (Hodgson 2014: 96). For comparison, a live performance of a rock band features numerous separate timbral actors, such as a guitarist, a bassist, a keyboard player, a vocalist, a drummer, and so on, while records produce a stereo signal with distinct left and right components, which together form a single perceptual stream (Moore 2013: 283-4, 300-303). In following the example of other MPS scholars, I use the term *timbre* to refer to a record's overall sonic colour (Cousins & Hepworth-Sawyer 2013: 91-131; Hodgson 2010: 206; Katz 2007: 103-4). Thus, chapter 3 elucidates timbral modification techniques essential to the practice of audio mastering.

The dissertation's final chapter is a case study describing the audio mastering session for my recently released EP, *Summoner* (2017). This record is available via Spotify, Apple Music, Amazon, 8tracks, Pandora, Tidal, and numerous other digital streaming platforms. Given the availability of digital recording tools, many artists now master their own records. Indeed, services such as SoundCloud demonstrate the immense popularity of DIY recording. Thus, this case study demonstrates an increasingly common scenario in today's music production climate, wherein artists create, mix, and master their own records. To master this record, I apply many of the techniques and methods elucidated in Chapters 1-3, thus providing a musical context for these techniques. However, I do not employ every single technique discussed in the first three chapters. To do so would not accurately reflect the mastering process for commercial releases. Hence, I mastered my record using only the techniques which I felt contributed the project's musical goals.

Chapter One

Audio Mastering:

Sonic Expertise and Musical Proficiency

In this chapter, I survey the audible aspects of recorded musical communications that audio mastering engineers routinely address. I thus: (i) consider those areas of recorded musical communications that mastering engineers are typically responsible for finalizing; (ii) detail the most prominent sonic parameters they consider when finalizing those areas; and (iii) explain some of the more crucial methods engineers use to evaluate a record's foundational psychoacoustic features. This will, in turn, provide a helpful musical context for the tools and techniques I consider in later chapters of this dissertation.

Audio mastering is an art form that is rooted in the perception of sound. As mastering engineer Mandy Parnell (in Hepworth-Sawyer & Hodgson, forthcoming) explains:

For great mix and mastering engineers, it's not about the tools. It's about the ears and how we hear. It's about how we interact with sound. We try different pieces of equipment because we're looking for a sound that we perceive we're hearing in our heads, and we go to find it.

In this chapter, then, I elucidate the process Parnell describes. The chapters that follow consider in greater detail the specific tools and techniques engineers have devised to *actualize* what they *hear*.

An Overview of the Mastering Process

This section provides a broad survey of the tasks associated with audio mastering, and its historical importance to record production. In so doing, I clarify some of the most crucial creative and technical tasks required of mastering engineers. In order to finalize records,

mastering engineers must first import, or *capture*, audio data.¹⁵ At this point they process, sequence and format this audio data, and deliver it in a completed state to their client(s) (Cousins & Hepworth Sawyer 2013: 51).¹⁶ While sequencing is not always necessary — such as, for instance, when engineers master single tracks — signal capture, signal processing, formatting, and delivery always occur during audio mastering (Figure 1.1). I should also note that, although it is generally understood that the lion’s share of an engineer’s time and attention are devoted to signal processing, the activities of capture, sequencing, and formatting require equally significant musical attention from mastering engineers (Cousins & Hepworth Sawyer 2013: 51).¹⁷ I consider each of these component procedures below, in turn.

Figure 1.1

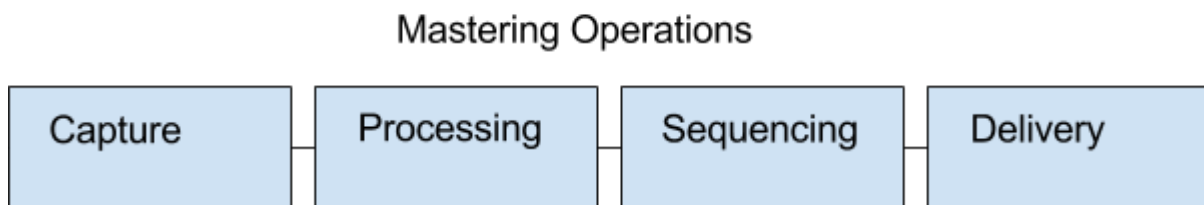

Figure 1.1 illustrates the typical sequence of events in a mastering session.

Capture

Every mastering session begins with “audio capture,” that is, with importing or transferring previously recorded music into the mastering engineer’s technical environment. In most

¹⁵ This step may simply include importing audio into a DAW, but it may also include capturing audio inside of an alternate medium, such as tape.

¹⁶ By *sequence*, I refer to the order of songs on a record.

¹⁷ As a matter of fact, these practices date back to the advent of tape recording in 1948, and continue to remain relevant today (Owsinski 2008: 4-5; Cousins & Hepworth Sawyer 2013: 51).

cases, clients provide 24-bit/96kHz “.wav” files. This first number refers to a recording’s *bit depth*, and the second number refers to the sample rate. The term *bit depth* is used to describe the number of binary bits used to digitally store amplitude measurements of an analog waveform. *Sample rate* refers to the speed at which an analog signal is sampled.

Most often, engineers import a stereo *premaster* into a digital audio workstation (DAW). Source material, however, may also come from analog media, such as tape or a vinyl disc (the latter is especially common when mastering engineers are hired for preservation and restoration work). In these cases, an analog-to-digital conversion of the source material must take place for digital processing to occur.¹⁸ This conversion is performed using an analog-to-digital converter (ADC). For an effective commercial-grade transfer, the ADC must exhibit sufficient “quality standards,” which engineers are responsible for knowing (Cousins & Hepworth Sawyer 2013: 53).

Indeed, not all ADCs are created equal. ADCs routinely imbue signals with varying levels of colouration (that is, they regularly create a *non-linear transfer* of data), deriving from the amplitude of the incoming signal and the unique circuit topologies of each ADC unit.¹⁹ The same thing occurs in the digital-to-analog converters (DACs), which engineers require to facilitate playback. Engineers also use DACs to send a signal to “outboard” (e.g., analog) equipment (Figure 1.2). “Outboard” processors usually operate in the analog domain, and thus, these devices process voltages rather than binary code. To use this equipment, engineers must use DACs to convert digital code into alternating current, suitable for analog processing. As Ken Pohlmann (2006: 1) notes:

¹⁸ Digital recording systems encode analog sound using a method known as pulse-code modulation (PCM). PCM audio is the standard form of digital audio used on computers and CDs, for example. Analog signals are converted by sampling the signal’s amplitude and quantizing these values for digital representation.

¹⁹ In signal processing, a nonlinear filter provides an output signal that cannot be expressed as a linear function of the input signal. A linear function can be expressed by simply adding or multiplying its component vectors. For example: $f(x + y) = f(x) + f(y)$; $f(ax) = af(x)$. Thus, non-linear signal processes provide an increased level of signal colouration.

It is perhaps ironic that although meaningfully audible audio signals exist only in the analog domain, they are best stored in the digital domain. Moreover, the tasks of converting audio signals into the digital domain, and back to the analog domain, are among the most difficult in digital audio technology. Indeed, the only steps in the complete audio signal chain that are more problematic are the transducing of signals from acoustical to electrical, and back again from electrical to acoustical—in other words, what is done by the microphone and loudspeaker. The final irony is that Edison and other audio pioneers did not have to contend with A/D [(analog-to-digital)] and D/A [(digital to analog)] converters, or even microphones and loudspeakers. Their all-acoustic audio systems were “all natural.”

Though “audio capture” may seem as simple as routing a signal to particular technologies, and then letting those technologies perform the tasks they were designed for, analog-to-digital and digital-to-analog conversion are anything but straightforward technical tasks. In fact, audio capture can become an extremely complicated part of the mastering process, especially when engineers use outboard gear to achieve a particular balance or tone. Modern mastering requires engineers to transfer musical data to and from analog and digital states repeatedly, because signal is sent to outboard gear and back to the computer before going to whatever monitors the engineer uses.²⁰ As a matter of fact, all digital music reproduction devices feature some form of DAC, which transforms digital code into analog voltages. Even our cellular phones — and quickly disappearing mp3 players — feature DACs that convert ringtones, and other such auditory stimuli, into a format which the phone’s speaker can play.

²⁰ It’s worth noting that even projects that rely entirely on digital technology, from start to finish, require DACs for monitoring.

Figure 1.2

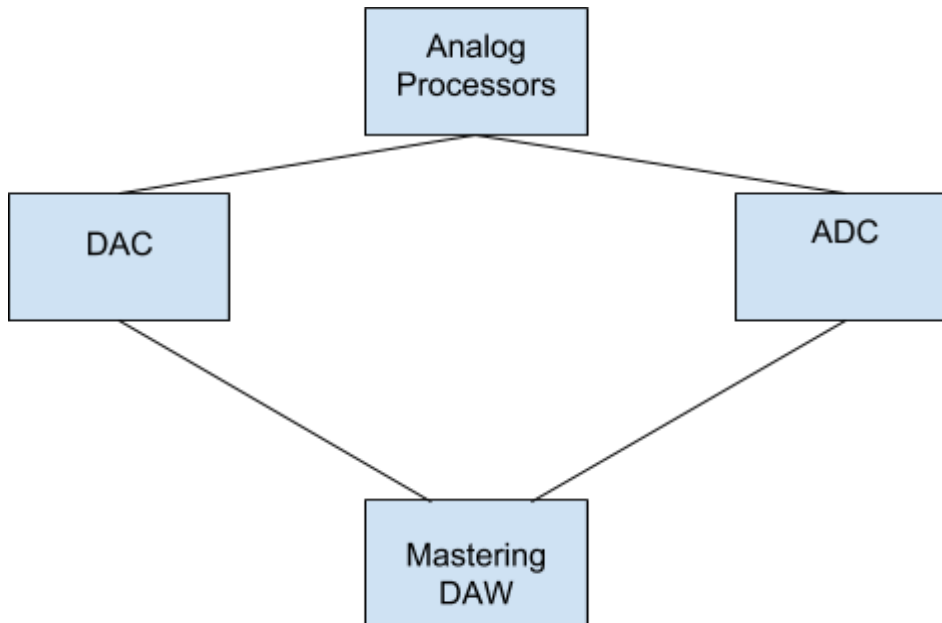

Figure 1.2: The image above illustrates the connection between a modern mastering DAW and analog processing equipment.

Audio mastering requires far more sophisticated DACs than those available in modern cellular phones, however. The mastering engineer’s understanding of each DAC’s peculiar biases is as sophisticated as their understanding of the other technologies they use, such as EQs, compressors, and so on. Within the art of audio mastering, in fact, a divide exists between those who use so-called “clean” or “transparent” converters, and those who use converters to alter signals in specific ways. Bob Katz speaks to this divide in an interview

featured in Russ Hepworth-Sawyer's and Jay Hodgson's *Audio Mastering: The Artists* (in Focal Press: forthcoming):

There are mastering engineers who use coloured converters on purpose. That's not my philosophy. I would rather let whatever analog processing that I choose to use provide the colour. Even the word colour is controversial because it tends to be shorthand for the compressor, expander, equalizer or other processor. I believe in having accurate converters, however. I've gone through a bunch of converters and obviously in mastering 99% of our sources are digital these days. There was a period of time where mastering engineers getting analog tapes would run it through their chain on a way to an ADC and call it a done day. Even when I was getting a lot of analog tapes I might do some initial EQ in the analog domain. Then I might do further work in digital domain after it arrives in digital domain.

I have many favourite converters, but I've currently settled on the Prism converters because they're the most transparent I have heard. How do you know what's transparent? You take your source on your DAW and you monitor it directly through your monitor converter and then you insert in the middle of that a D to A going into an A to D and then do that to your converter. The winner of transparency contest is the one that sounds closest to you, and you can't tell whether it's on or off. There is no transparent converter chain but the Prism comes closest for me.

Converters, like many other signal processors, take on what we might call an “instrumental” quality for many engineers. Indeed, converters are as crucial to mastering engineers as guitar brands can be to guitar players. Electric guitarists may opt for a Les Paul style instrument rather than Fender Stratocaster, for instance, because the two instruments produce quantifiably different sounds (Martin 2014: 1-3). The same is true of mastering engineers who treat converters, or sets of converters, as an integral part of their “signature” sound. Prism converters, for example, are a popular choice amongst mastering engineers like Bob Katz, Mandy Parnell and Nick Watson, who prize their “transparent,” or “accurate” and “uncoloured,” transfer profiles. But other engineers may prefer more “coloured” converters, like the SSL MADI Xtreme or any of the 500 series converters currently available as part of API's “lunchbox” environment.²¹ Usually, though, it's pure practicality that wins out in the

²¹ Colouration, in this case, refers to a non-linear transfer of data (as described more thoroughly in footnote 19, page 28).

decision-making process, and engineers make their choices primarily based on availability.

As Ellen Fitton (in Hepworth-Sawyer & Hodgson, forthcoming) notes:

I loved the dCS Converters, and the Sontec EQs were just fabulous. Besides how they sound, in this situation, Sontec EQ isn't what I wanted, but it was available at the time. As a result, I found a chain that worked with what gear I had. Maybe it was the dCS into the Sontec, which over the last few years was a very common signal chain for me. As opposed to other converters that I had, I just liked how the dCS converter sounded through the Sontec.

Audio capture also involves a form of data management. That is, in addition to concerns over conversion, engineers must also manage the data format of the material they master. In some cases, engineers may work entirely (or perhaps *mostly*) within the analog domain (“out of the box” or “OTB”), although this situation is increasingly less common.²² For engineers who master records using digital technology, care must be taken when importing audio data because critical mismatches in audio formats can halt productivity. Moreover, clients often provide audio in non-ideal states. A number of the available audio formats have become “industry standards” through routine usage, such as the 96 kHz/24-bit and 44.1 kHz/16-bit protocols.²³ If 96kHz/24-bit audio is the preferred format, or if the client desires a “mastered for iTunes” endorsement of their record (which requires this format), but the client’s studio can only provide a 44.1kHz/16-bit audio file, then this mismatch must be rectified by the mastering engineer. In this case, the mastering engineer may either reconfigure their equipment to accept the supplied sample rates and bit depths, or convert the source material to a new standard format.

²² For more on this phenomenon, please see Hepworth-Sawyer & Hodgson (Routledge/Focal Press, forthcoming).

²³ CDs continue to use 16-bit/44.1kHz PCM encoding.

Signal Processing

Signal processing refers to the act of modifying audio signals via software *plug-ins*, or hardware units. Commonly used signal processors include EQs and compressors, for example. During audio mastering, signal processing can only occur once a recording is captured or imported into the engineer's work environment, such as a DAW. Mastering engineers typically allocate most of their time to signal processing.

In order to begin processing source material, engineers first conceptualize the overall desired sonic aesthetic for the recording before applying signal processing tools to establish these sonic characteristics. Adam Ayan (in Hepworth-Sawyer and Hodgson: forthcoming), of Gateway Mastering, describes his approach to signal processing as follows:

For every track, the first thing I'm going to focus on is any corrective EQ or other corrective measures I have to enact on the mix. In other words, if things *jump out* as being just plain wrong, then those are the things I need to address first before I can delve into the more creative part of what I'm doing. So in other words, if there's too much bass response in the track overall — it's boomy — the first thing I'm going to be working on is fixing that issue, and making that work before I delve into anything else. So corrective EQ or corrective measures are the thing I look for first. This generally means that I'm listening for a good overall balance in terms of frequency response that is appropriate for the recording in question. Also, most of my clients fall under the umbrella of pop music, so vocals are really important within that genre. On the first or second listen, I'd be making sure the vocals are *hitting me* just right. Are they *present* enough; are they *loud* enough; are they *clear* enough; are they *right where they should be*? And that follows suit for virtually all of the recordings I work on. I work on very few instrumental recordings, and again most of the stuff I do would fall under that pop music category. Whether it's pop music being commercially released — you know whatever, rock, pop, country and all of that — or otherwise: the vocal is always so important. I'll spend a lot of time focusing on the vocal at the beginning as well.

Ayan's account in the passage above describes how the majority of mastering engineers work (Hepworth-Sawyer & Hodgson, forthcoming). He clarifies that signal processing requires constant aural assessment on the part of mastering engineers. While engineers evaluate (and re-evaluate) a signal, they make changes that reconfigure the record's

sonic properties. It is the signal processing stage, in fact, wherein the majority of a record's sonic parameters are decided upon. During this phase, engineers finalize a record's stereo image, its noise characteristics, depth profile, spectral contour, and dynamics and loudness profiles. It is important to note, as well, that engineers do all this with an *ear* towards some straightforwardly musical goal, even while they remain ever cognizant of a host of technical concerns.

Mastering engineers use signal processing to address five broad aural parameters: dynamics, timbre, loudness, stereo width and depth (Cousins & Hepworth-Sawyer: 54). Musicians and scholars alike often discuss the first two of these, namely, dynamics and timbre.²⁴ Dynamics, in both recorded and live music, refers to the alternation of *loud* and *soft* passages within a piece; and timbre refers to the general *tone colour* of an instrument, sound, or recording.²⁵

On the other hand, loudness, width, and depth considerations – parameters that engineers and recordists establish – rarely receive scholarly discussion. The Advanced Television Systems Committee (a group that designates broadcast standards) defines loudness as “a perceptual quantity; the magnitude of physiological effect produced when a sound stimulates the ear” (2013:14). Width refers to the design of a record's stereo representation, and depth describes a record's ambient characteristics (Cousins & Hepworth-Sawyer 2013: 169, 178). In fact, as we shall see in later chapters, these three aural parameters are entirely

²⁴ I here consider timbre and dynamics as plainly musical concerns because in live music, these two sonic categories result from compositional and performance choices. Dynamics markings, for example, have been used by composers extensively since the late 18th century. In addition, timbre can be understood to be a result of arrangement and orchestration strategy, as well as performer input. As a result, I consider dynamics and timbre to be within the purview of traditional musical concern — even though the object of study (the recording) is less traditional.

²⁵ Engineers define timbre as the result of a sound's spectral distribution (Cousins & Hepworth-Sawyer 2013: 92)

musical domains.²⁶ Music researchers must simply adjust the way they listen to records in order to hear and understand these musical properties.

The signal processing tools mastering engineers most commonly use are compressors/limiters and equalizers. But they also use a number of other signal processing tools to accomplish a range of goals, such as saturation, excitation, expansion, stereo-field manipulation, dynamic reduction by frequency range, transient shaping, and noise removal.²⁷ I consider each of these procedures in more detail below, as well as in the later chapters of this dissertation.

Sequencing Programme Material

Another creative task mastering engineers regularly perform is known as “sequencing,” that is, the act of determining the order of songs on a record. Some tasks associated with sequencing are *topping and tailing*. These duties entail placing audible gaps between tracks on a record, as well as the establishment of fade-ins and fade-outs for individual songs. Despite the prevalence of online streaming (of individual tracks), sequencing remains a relevant endeavour, as Bob Katz explains (2007:93):

Although we are in an era of digital downloads, an emphasis on singles and a shorter attention span of the listening public, the record album is still an important music medium. Sergeant Pepper is often cited as the first rock and roll *concept album*, i.e. an elaborately-designed album organized around a central theme that makes the music more than a simple collection of songs. This started a trend that many assume has more or less died. Is the concept album really dead? Not for me; I treat *every* album that comes for mastering as a *concept album*, even if it doesn't have a fancy theme, artwork or gatefold. Song spacing and leveling contribute greatly to the listener's emotional response and overall enjoyment. It is possible to turn a good album into a *great album* by choosing the right song order. The converse is also true.

²⁶ Here I use *musical* to describe that which pertains directly to the experience of *music*. For instance, records are musical artifacts that cannot be experienced without also hearing meticulously crafted loudness, width, and depth profiles.

²⁷ Transients are the high amplitude and short duration sounds that occur at the beginning of a waveform.

It is also worth noting, however, that projects do not always require sequencing. Electronic Dance Music (EDM) for instance, along with some other popular music forms, usually forego album sales in favour of distribution as *singles*. Thus, mastering engineers working in these genres simply have nothing to sequence.

Formats and Delivery

A record's destination format may be a physical form, such as vinyl, tape, or CD. Or, the release may be intended for streaming. In addition, mastering engineers account for numerous *file formats* which are encoded using codecs such as .m4a, .mp3, .aiff, .wav, and others (Cousins & Hepworth-Sawyer 2013: 214).

Surprisingly, an artistic *modus operandi* also instructs format selection and management within the practice of audio mastering. Although this may understandably raise the suspicion of some readers, format management during the recording and production process is not a straightforwardly technical phenomenon. Mastering engineers have always taken great care to ensure that audio is well-represented according to the unique biases of each destination format. In addition, audio is almost always transferred from one format to another, in order to complete the recording process, and mastering engineers manage audio for representation within many available audio formats.

In fact, audio mastering initially emerged to address format compatibility issues facing recordists in the middle of the twentieth century. By 1948, Ampex had debuted a new device for storing recorded sound: the magnetic tape recorder. However, the listening public at this time were already thoroughly invested in the playback of vinyl discs; and, of course, it is not possible to play a tape recording using a vinyl player.²⁸ Even so, magnetic tape allowed the possibility for recording at a higher resolution than vinyl, and thus yielded what we might

²⁸ The first vinyl discs were made commercially available in 1931 by RCA Victor.

call, for lack of a better term, a more “realistic” sound. This increased auditory *realism* results directly from tape’s enhanced dynamic and spectral reproduction capabilities, and, indeed, tape can reproduce a far greater range of frequencies, as well as a greater dynamic span, than vinyl. Faced with the issue of implementing tape-based recording technology without building a new type of consumer tape-player, recording industry personnel developed a process known as *transferring audio* from tape to vinyl as a solution.

Current audio mastering practice is directly tied to the history of transferring audio (Owsinski 2008: 4).²⁹ The individuals responsible for transferring audio from tape to vinyl came to be known as *transfer engineers*. These engineers oversaw the process of transferring audio from one medium to the next. They also began to alter the spectral distribution of records during this transfer process. For the simple reason that vinyl discs could not handle over-abundant low and high-range frequencies, or overly wide dynamic ranges, engineers began removing excess energy in these spectral regions. The presence of these sonic offences causes a record needle to *skip* or *jump* over the grooves of the disc, which results in a deficient playback experience. To combat these issues, transfer engineers employed signal processing techniques known as equalization (EQ) and dynamic range compression (DRC). These techniques effectively *tame* tape recordings into a form more suitable for vinyl playback.³⁰

Over the following decades, audio transfer adopted more of an interventionist approach, and by 1960, transfer engineers, now known as *cutters*, were responsible for finalizing a record’s sound parameters as a matter of course (Hepworth-Sawyer & Hodgson, forthcoming). A number of freelance mastering engineers emerged during the era of the

²⁹ Such techniques are particularly relevant in the current industry climate, wherein vinyl discs, CDs, tapes, and numerous streaming platforms coexist.

³⁰ For more on the history of mastering and signal processing, please see: Rabiner et al. (1975), Katz (2007), Owsinski (2008), Hepworth-Sawyer (2009), Hodgson (2010), Golding & Hepworth-Sawyer (2011), Cousins & Hepworth-Sawyer (2013), Hepworth-Sawyer & Hodgson (forthcoming).

cutting engineer (c. 1960-1980), and many dedicated mastering houses were established in the 1960s and 1970s as a result. Denny Purcell in Nashville, Bernie Grundman in L.A., and Bob Ludwig and Bob Katz in New York City, for example, began to enjoy success throughout the 1970s, as artists came to place a high value on the services mastering engineers offered. In fact, the Band famously fired the in-house mastering engineer at Capitol in 1973 to hire Bob Ludwig. The resulting album, *Moondog Matinee* (1973), celebrates Mr. Ludwig's work with a citation that reads, "Mastered (as always) by Bob Ludwig at Sterling Sound" (1973).

These cutters were indeed remarkably influential in determining sonic output of records released in the 1960s and 1970s. However, the 1980s ushered in a new era of digital audio, which restructured the art of mastering records once again. In fact, the term *mastering engineer* only began to receive routine usage in the 1980s as the recording industry embraced digital technology (Hepworth-Sawyer & Hodgson, forthcoming). Many mastering engineers during the 1980s still performed the majority of their work on analog equipment, but they were also required to transfer their work to a digital recorder.³¹

The widespread acceptance of digital technology fundamentally altered the way mastering engineers performed their duties, and many of the general sound characteristics of records also changed as a result of the increased dynamic and frequency reproduction capabilities of digital recording. Digital sound systems, for instance, rely on *sampling*, rather than analog voltage data, to codify sound as binary data. As a consequence of relying on numeric data instead of physically degradable analog media, digital sound systems theoretically offer a more consistent listening experience. As Akio Morita, co-founder of Sony, explains, digital recording technology aims to offer the possibility of "perfect sound forever" (quoted in Murray 2013: 2). In contrast to analog recording, early digital recording

³¹ The first example of this is the SONY PCM 1600, which is a video recorder capable of quantizing analog signals to 16-bit/44.1 kHz.

systems not only required new specialized skill sets, but also enabled new possibilities for the capture, refinement, distribution, and playback of recorded music.

Once digital media was firmly entrenched as the standard in the global recording industry, a plethora of new digital listening formats became available. The first commonly used digital platform, the compact disc (CD), quickly paved the way for discless digital media. By the mid to late 1990s, consumer computers could play PCM “.wav” files directly, as well as a new data-compressed codec called mp3, and in the early 2000’s, mp4, AAC, FLAC, Ogg/Vorbis, and other codecs were developed. Now, given the diversity of available audio formats (e.g. vinyl, tape, and digital), mastering engineers may deliver a number of distinct masters to a client for playback via different platforms such as iTunes/Apple Music, SoundCloud, Spotify, YouTube, vinyl record, tape, CD, and others (Cousins & Hepworth-Sawyer 2013: 214).³² To facilitate translation to various audio file types, mastering engineers use tools to audition source material as though it had been encoded by various codecs. These software plug-ins emulate the spectral and dynamic profiles these codecs impose upon a recording. In other words, engineers can mimic various data compression algorithms by using plugins that cause a signal to sound as if it were encoded using a format such as mp3. The Sonnox Fraunhofer Pro Codec, to provide an example, allows for real-time comparison of mp3, AAC-iTunes+, AAC-LC, HE-ACC, HE-ACC v2, MPEG surround, AAC-LC Multichannel, HE-ACC multichannel, and HD-ACC (Sonnoxplugins 2015: 1; Figure 1.3).³³

³² I.e.: AIFF; AAC; OGG/Vorbis; MP3; MP4; PCM WAV; and others.

³³ According to Sonnox, this plug-in is primarily used to audition source material as though it were encoded using an available codec: “We spend our professional lives making mixes sound as good as they can – and then hand them on for encoding and distribution. Later we often wish we could have made some improvements. What if there was a way to audition and compare up to five audio codecs in real time? Enter the Fraunhofer Pro-Codec Plug-In.” Users can also export from within the plugin, but it is unlikely that anyone would use this feature during mastering. In fact, Sonnox recommends that users reserve the online encoding feature for works in progress, such as mixes: “In general, offline encoding with the Pro-Codec Manager application should be used when a bounced WAV/AIFF file exists. If there is no WAV/AIFF file (perhaps instead there is a work-in-progress mix) online mode will be quicker and easier, hence more appropriate” (72).

Figure 1.3

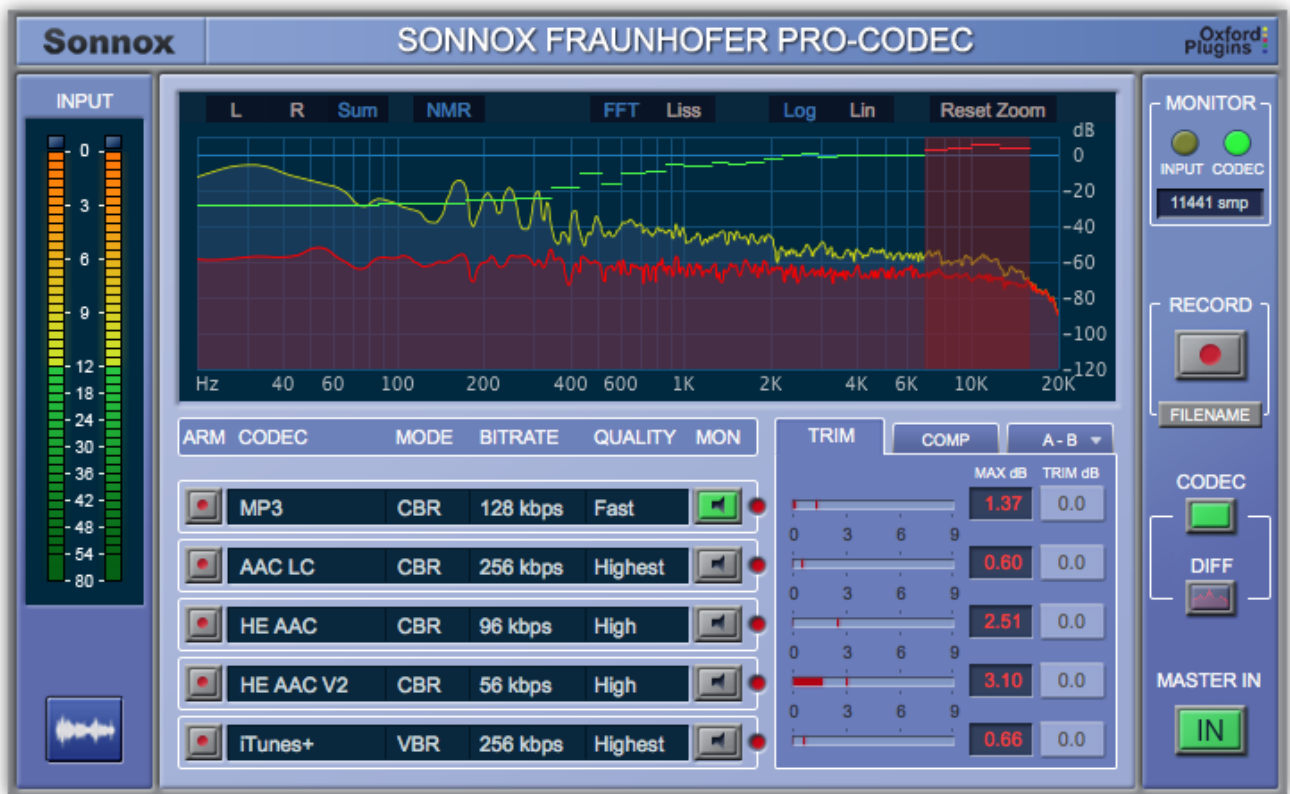

Figure 1.3 illustrates the Fraunhofer Pro-Codec plug-in. This software allows users to audition source material as though it were encoded via the various codecs developed by Fraunhofer IIS.

Apple has also developed tools that benefit the mastering community at large. *Mastered for iTunes* software functions as a plug-in, for example, that allows engineers to audition source material as though it were encoded via the standard format Apple accepts (AAC, at a sample rate of 96kHz and bit depth of 24-bits). With music distribution giants such as Apple investing in tools for improving audio masters, the process of audio mastering may currently be more important than ever before. To demonstrate the importance of audio

mastering to current music listeners, a companion text is packaged with Apple's software that describes how mastering engineers facilitate modern listening experiences (Apple 2012: 3):

When creating a master, mastering engineers take into account the limitations and characteristics of the medium or destination format, as well as the listening environment of their audience. For example, a master created for vinyl is unlikely to be listened to in an airplane or car, and therefore is often mastered for a listening environment where a listener can hear and appreciate a wider dynamic range. Similarly, a master created for a club environment might take into account the noisiness of the intended listening environment.

Because iTunes [Apple Music] is a highly portable format, its files have the potential to be listened to in a wide range of different settings. So while one listener may be using white earbuds while riding in a loud subway car, another may wind up listening intently to a Bach cantata on AirPlay- equipped Bowers and Wilkins speakers or on a similarly equipped Denon receiver in a home media room. Just as likely, a college student may be deep into Miles Davis' *Sketches of Spain* while sporting Dre Beats headphones in the campus library. Keep in mind that Apple has sold more than 250 million iOS devices, and that many, many people around the world are listening to music on their iPods, iPhones, or iPads.

[With the Mastered for iTunes software,] you're being provided with all the tools you'll need to encode your masters precisely the same way the iTunes Store does so that you can audition exactly what they'll sound like as iTunes Plus AAC files.

This quote from the Mastered for iTunes handbook explains both the historical and the continued need for mastering engineers to alter recordings according to playback format requirements. While in 1948 there were two major formats for storing audio — tape and vinyl — there are now countless digital file types in use. Each of these has distinctive sonic biases.

It should also be noted that Apple describes diverse generic applications for its software. One listener may prefer Bach cantatas, and another may prefer Miles Davis, but both classical and jazz records must be mastered before they can be made available within the iTunes library (or any digital library). The Mastered for iTunes companion text suggests that all genres of music can — and currently do — benefit from mastering processes that consider the sonic strengths and limitations of the distribution format. Indeed, audio mastering was born from the need to address the consumer playback experience of recorded

music, and this tradition continues today in the digital music-making paradigm, as new innovative formats for audio storage are developed.

Width/Depth, Noise Management, and Loudness

Of the four tasks I consider above (i.e., capture, sequencing, signal processing, formatting/delivery), mastering engineers spend the majority of their time on signal processing. During this phase, engineers finalize a record's spectral distribution, noise characteristics, stereo width and ambient profiles, spectral balance, and *loudness* profile. I consider each of these aural components below, but I leave dynamic structure and spectral balance for Chapters 2 and 3.³⁴

Establishing Stereo Presentation, *Width*, and *Depth*

Most recorded music is released for playback within the two-channel stereo paradigm, and stereo sound has been the industry standard for record playback since the late 1950s, showing no signs of declining in popularity despite the availability of more elaborate multi-channeled playback methods, such as 5.1, 7.1, or even 22.2 (Martin 2016: 14-25). One needs only to take a cursory glance around a busy street to see that earbuds and headphones — quintessential *stereo* technologies — are extremely popular. In addition, recent consumer trends further establish that high quality headphones are growing in popularity. The market for such headphones saw an increase of 73% in 2012, for instance, as a result of the popularity of *Beats by Dre* headphones (Neate 2013:1).

While perhaps taken for granted as a long-standing and ubiquitous procedure, recordists consider stereo representation carefully. Although humans have two ears that

³⁴ Loudness and dynamics are related areas. I introduce some basic dynamic concepts in this chapter's section on "Loudness," and then proceed to discuss how loudness and dynamics are altered in Chapter 2.

operate binaurally, stereo sound reproduction hardly emulates the way we hear. For instance, apart from stereo records, how often do humans hear a single composite sound (such as a record) emanating from two distinct sources? The answer is *never*: in nature, each sound forms its own perceptual stream (Moore 2013: 289). Stereo creates the psychoacoustic illusion of a phantom *center* image by providing two equal *side* signals (Cousins & Hepworth-Sawyer 2013: 174). For this reason, many recordings seem to contain a vocal that originates from the *center* of this image. However, since this center image exists only as an auditory mirage, engineers can manipulate the stereo soundstage of a record to create a psychoacoustic perspective on a sound event that never actually occurred (Hodgson 2017: 216).³⁵

Although the most valuable tool for assessing a stereo signal are one's ears, engineers also use visual methods of assessment. The relationship between left and right speakers, or *phase coherence*, is monitored via a *correlation meter* (Fig. 1.4).³⁶ The correlation meter provides information on how related, or unrelated, the left and right speaker signals are to one another. However, a highly correlated mix is not always more desirable than a less correlated one, and different projects require different approaches to phase coherency. For example, music intended for commercial playback tends to exhibit a higher degree of correlation between the left and right speakers. Perhaps this is because FM radio remains a popular medium, which also demonstrates the tendency to broadcast in mono when signal strength is weak (Cousins & Hepworth-Sawyer 2013: 174).³⁷

³⁵ While these sounds do *occur* upon playback, they never existed in the way one typically conceives of a *live* or *natural* sound event. Thus, the sounds presented on records cannot occur in the absence of recording and playback technology.

³⁶ Phase denotes a particular point during a waveforms cycle. For a stereo signal to be completely *phase coherent*, both left and right portions of the signal must be identical. However, stereo mixes are rarely entirely coherent in both speakers, except for low-frequency information.

³⁷ When FM radio signals are weak, they are often reduced to a mono signal (Cousins & Hepworth-Sawyer 2013: 174).

Figure 1.4

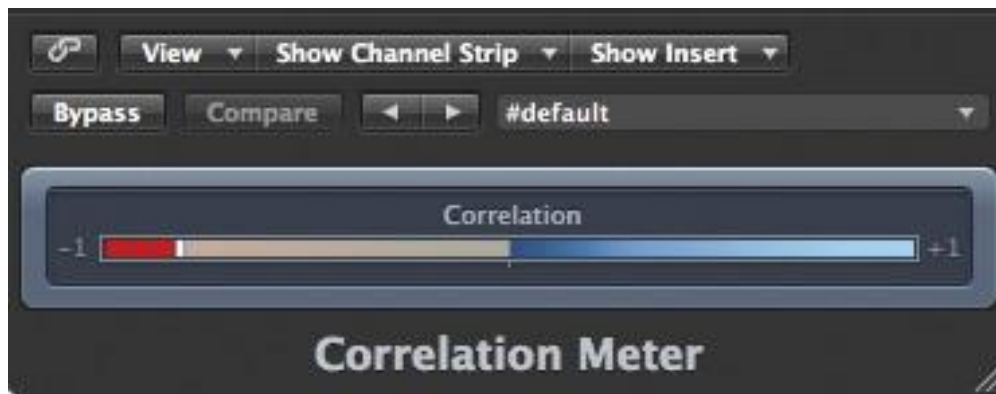

Figure 1.4 shows Logic Pro's native correlation meter.

In addition, many people continue to listen to music on mono television sets, mono kitchen radios, and on single-speaker commercial installations which only offer mono playback capabilities. Perhaps the most common use of mono sound in contemporary music is in dance clubs. Although two large speaker arrays often deliver sound to patrons, these arrays are always configured for mono playback. If clubs configured the arrays to operate in stereo, listeners would experience a drastically different sounding mix as they move around the club. Hence, speaker arrays are always configured for mono playback. Composers of dance music, who often also perform in such venues, are keenly aware of this limitation, and often ask their mastering engineers to ensure their work demonstrates a high degree of mono compatibility.

One of the duties of a mastering engineer when working on commercial music then, is to ensure that programme material can be presented in both mono *and* stereo. However, non-commercial music, or audio used for games or television, may not demonstrate the same level of phase coherency. As a result, engineers may ask clients if the recording is to be played in a club, or, is it perhaps for a movie soundtrack? In the first case, a high degree of mono

compatibility is necessary to accommodate club playback systems. In the second case, a movie soundtrack may require a more loosely correlated left and right speaker image to take advantage of 5.1 surround theater systems, such as the household systems offered by Bose, Sony, Panasonic, and countless others.

In order to alter a recording's stereo phase relationship, mastering engineers have a number of tools at their disposal. Perhaps the most effective method for achieving stereo field alteration at the mastering stage is Mid/Side (M/S) processing. An M/S processor allows engineers to control a stereo signal's *side* and *middle* portions separately.³⁸ M/S processors accomplish this by providing engineers access to the *sum* of both left and right signals, as well as the *difference* detected between these two signals. M/S compression, for instance, can be used to enhance the perceived *power* of the center portion of a mix, and M/S EQ can enhance the perceived "air" (high frequencies) contained in the "sides" of a mix (Cousins and Hepworth-Sawyer 2013: 176). That is to say, M/S EQ allows engineers to control frequencies perceived to emanate from the far left and right regions of a stereo image, and to change the stereo balance of a record in the process (Figure 1.5). This process can also be applied to alter a stereo signal's perceived *center* region.

Audio Example

Audio example 1.1 illustrates the application of M/S EQ on the master bus. As engineers often do, I use M/S EQ to reconfigure the track's low frequency content for mono representation. For demonstration purposes, the mid and high frequency content on this track is slightly exaggerated in the outer portions (i.e. *side* channels) of the signal. The track is first presented with no additional M/S processing at the beginning (00:00-00:15). After 15s, I

³⁸ M/S processing is discussed thoroughly in Chapters 2 and 3.

engage the M/S EQ.

Another classic method for increasing stereo width uses a stereo delay in order to create the illusion of a widened stereo image.³⁹ A simple stereo delay placed on the master bus, with up to approximately 0-30ms lag time in one channel (either the left or right), creates the illusion of a wider stereo image (Cousins & Hepworth-Sawyer 2013: 177). This technique takes advantage of the Haas, or *precedence* effect, wherein a short time delay separates the two channels of a stereo signal, so that the resulting sound appears to emanate from whichever side occurs first (Haas 1971: 146-159). When delay times exceed approximately 30ms, however, listeners begin to perceive the resulting auditory image as two separate streams, or more accurately, as a distinct echo of the first sound.

Audio Example

In audio example 1.2, I demonstrate the Haas effect applied to a single instrument. To do so, I allow the instrument to play without the addition of stereo delay for 15 seconds. At this point, I change the delay length in the right speaker to 10 m/s (00:15), 20 m/s (00:30), and then 30 m/s (00:45).

³⁹ Delay is an audio effect that causes a signal to occur at a later point in time. Delay can simulate an echo effect by taking advantage of a *feedback* mechanism, or it can simply cause a signal to occur later than originally intended.

Audio example 1.3 applies the Haas effect to a completed stereo mix. The track plays without stereo delay for 15s (00:00-00:15). At this point I apply a stereo delay, but the settings are somewhat exaggerated in order to highlight this process for listeners. At 30s (00:30), I invoke a more common use of the delay.

Although the Haas effect is categorized as a stereo field adjustment, it also reconfigures the *depth* characteristics of a record. Engineer/researchers Mark Cousins and Russ Hepworth-Sawyer define depth as follows (in 2013: 178):

Depth is more conceptual [in mastering] as there's no dedicated slider, or direct widget, that can move a particular sound or frequency back and forth in the mix — certainly not for mastering anyway. To a large extent this 'parameter' will be predetermined by the mix engineer and what you receive, but nevertheless it is something to pay attention to as there are some manipulations you can apply.

Indeed, although many of the basic depth characteristics of a recording are encoded during the mixing phase, mastering engineers have tools and techniques at their disposal for adjusting this sonic parameter as well (Cousins & Hepworth-Sawyer 2013: 178).

When mastering engineers receive recordings that lack this illusory sense of depth, or space, it is often for three reasons: (i) the initial reverberant reflections of the sound source are mixed inaudibly (or are simply unavailable), (ii) the record was made in a dead room with no reverb, or (iii) a poor ambient processing strategy was applied (Katz 2007: 235). However, the act of adding artificial spatial details to a record is rarely as simple as applying reverb. Processing tools cannot recreate the early reverberant reflections that happen naturally between approximately 50 and 100ms after a sound occurs, for example.⁴⁰ Engineers call

⁴⁰ Although impressive convolution tools exist for recreating various spaces, human hearing is sensitive to the early reflections that occur naturally within a given environment. This is why great

these immediate echoes *early reflections*, and they must be present in order to establish a *realistic* sounding reverb profile (Katz 2007: 230). Conversely, records that lack early reflections tend to sound *dead* or *artificial*. This is because humans possess a highly attuned perceptual mechanism for locating sound (Moore 2012: 297). When any sound occurs, for example, it will reach a listener's left and right ears at different times, and it will sound different to each ear. Humans subconsciously use these subtle differences to *localize* sound, that is, to ascertain a sound's location (Moore 2013: 245).

Mastering engineers can enhance a record's depth characteristics through the application of reverb, although the technique is used infrequently. Experts agree that one must tread lightly when applying such ambient processing (Cousins & Hepworth-Sawyer 2013: 179; Katz 2007: 230). The primary issue with many reverb effects units and plugins is that they only provide broadband operation. That is to say, a broadband reverb unit applies ambience across a signal's entire frequency spectrum. When applied this way, for example, reverb usually causes low end frequencies to sound rather *muddy* (Cousins & Hepworth-Sawyer 2013: 180).⁴¹

Given this, iZotope Mastering Reverb in Ozone allows for narrowband operation, as do most mastering reverb units. Engineers using these devices can apply reverb to selected

care is taken by professional recording engineers to capture these short duration ambient reflections in well-designed rooms. True early reflections cannot be recreated via convolution, or any other software-based method. They can only be captured during tracking. However, engineers can *approximate* these reflections using available reverb technology, but professional recordings typically use this as a last resort (Katz 2007: 230).

⁴¹ While nearly all mix-level reverb plugins/hardware allow users to equalize the ambient sounds emanating from the device, this is still considered *broadband* operation. *Narrowband* reverbs, which are discussed in the next paragraph, only apply reverb to a designated frequency zone, such as 5-12kHz.

frequency bands, instead of the entire frequency spectrum.⁴² This helps them avoid applying reverb to undesired spectral regions.

Audio Example

In audio example 1.4, I apply a mastering reverb to a track in order to create a sense of space for a “dead”-sounding recording. The track plays unprocessed for 15s (00:00-00:15), before reverb is applied to the stereo bus. The amount of reverb used is subtle, yet greatly enhances what one might call the *believability* of this track.

Reverb is also applied when a live recording lacks sufficient room/crowd capture. In this case, reverb strengthens the *illusion* of a live recording (Cousins & Hepworth-Sawyer 2013: 180). In addition, this effect may be applied for the purpose of reinforcing a song’s fade out section. Here, engineers simply apply reverb as the programme material slowly diminishes to silence, and in so doing the record seems to move away from the listener. In fact, this technique simply mimics the perceptual profile of a natural sound source as it fades from the listener (Cousins & Hepworth-Sawyer 2013: 178).

Managing Noise

In addition to considering (and altering) the programme width, depth, and ambient qualities of a record, mastering engineers also manage and remove undesirable noises. By *noise*, I refer to clicks, pops, distortion, and related sonic artifacts that do not seem to belong on a

⁴² Nearly all reverb devices provide some form of filter. However, mastering reverbs differ by applying reverb to a target frequency band. Broadband reverb units, on the other hand, process the signal’s entire spectrum and then filter out unnecessary frequency zones after the fact.

record. The aesthetic goals of a project determine the engineer's choice of noise removal strategy, as many types of noise exist. In order to categorize common signal noise, Bob Katz offers the following definition (in Katz 2007: 139):

Specialists in any developed subject create a vocabulary to mark distinctions which are not generally noted, or even noticed, by the non-specialist. Although a layperson would lump distortion and noise together, an audio engineer characterizes distortion as a particular form of noise: one that is correlated with the signal. Distortion can be low level and sound much like what is normally called noise, or it can be high level and quite obtrusive, lying on the peaks of the signal.

Indeed, as Katz explains, the term *noise* applies broadly to any undesirable sound on a recording. Distortion, on the other hand, represents a type of noise that is directly correlated with the sonic properties of an incoming signal. For instance, the inter-sample peak distortion Katz mentions is caused when a recording's level exceeds 0 dbFS while it's being converted to voltage by a digital-to-analog convertor. These peaks in signal level can produce harsh distortion artifacts every time the signal crosses 0 dbFS.

Audio Example

Audio example 1.5.1, demonstrates the difference between *noise* and *distortion*. In the first segment (00:00-00:15), a drum track was extracted from a noisy vinyl disc. Listeners will notice intermittent pops and clicks as this segment plays. After a fadeout, the second segment of this example (00:15-00:30) demonstrates the sound of distortion applied to the same clip.

What Katz fails to consider in his text, however, is that noise and distortion are commonly heard sonic components of popular records. Both hip hop and indie records — two widely influential popular music genres — frequently adopt noise and distortion as an

aesthetic feature. Both of these genres cherish certain clicks, pops, and hisses because many music fans and artists appreciate analog sounds in a general sense. A recent article in *The Guardian* (Fox 2014) discusses this type of audiophile nostalgia for analog sound as follows:

...[N]ever before has music been so available and yet so immaterial. Perhaps it's this immateriality that has provoked a revival of interest in older audio technologies, in ways of recording and listening that involve something more tangible than a stream of digital code. Tellingly, this is a revival led by people too young to have used these technologies when they were state of the art, probably even too young to have thrown that cassette tape out of the car window. It's this generation that is buying vinyl, and it's musicians of the same generation who are making the records, experimenting with tape recorders and enthusing about analogue sound.

Some of this is fashion, of course, an audio equivalent of steampunk or hipster beard-growth, but there's something more significant going on as well.

In fact, many indie and hip hop recordings are released on vinyl.⁴³ And, many digital releases from these genres intentionally feature the clicks, pops, and hiss associated with analog listening media.⁴⁴ Indeed, a puzzling trend towards unnecessarily valuing analog hiss and distortion persists in many genres of pop music now. As a matter of fact, on records, these noises are as important to some genres as cadences are to tonal music (Shelvock 2017: 175). Mastering engineers reconfigure a record's noise profile with the tacit understanding that certain noises may enhance the overall listening experience.

In addition to tape hiss and vinyl clicks and pops, noise is also introduced unintentionally. Such noises may include click track leakage, electrical noises, guitar amp buzzes, preamp hiss, extra noises made by musicians during or after *takes*, or any conceivable accidental event (Katz 2007: 139). Engineers classify these noises as either *continuous* or *impulsive*. Continuous noise demonstrates a regular dynamic characteristic, for instance, whereas impulsive noises are defined as events of short duration, such as clicks and pops.

⁴³ Even independent artists engage in this practice, such as Canada's Moore and Exit Only. (<https://moorenexitonly.bandcamp.com/>)

⁴⁴ This is typically accomplished by adding samples of vinyl hiss, or related noises (Shelvock 2017: 75).

Continuous noises are further divided into two categories: broadband and tonal (Katz 2007: 139). Broadband noise exhibits an identifiable frequency response, or general timbral colour, but otherwise doesn't exhibit a single strong frequency component, such as a fundamental frequency (e.g., air conditioner noise, computer fan noise, pink noise, and white noise). Tonal noise, on the other hand, contains distinct spectral components, such as the audible ground hum caused by power lines.⁴⁵ In addition to hum, buzz is another example of tonal noise that encompasses the higher harmonics related to power line frequencies. Buzz can also be audible across a number of upper partials such as 240Hz, 360Hz, and even up to 2,400Hz in severe cases (Katz 2007: 140).

Any combination of the noises discussed above can potentially appear on a record. However, the de-noising process itself is more complicated than simply engaging an automatic process (Katz 2007: 141). Instead, mastering engineers apply three different methods to deal with undesirable noises. One can simply ignore clicks, pops, or distortion; apply a filtration process that removes spectral energy; or apply a process for dynamic expansion. Mastering engineer Ellen Fitton, who primarily works on classical records, describes both historical and current attitudes towards digital de-noising as follows (in Hepworth-Sawyer & Hodgson: forthcoming):

You've always got to be careful. Aside from recording the artist, don't forget to record some room tone at the end of the day. Not only do you need it to hook the movements together, but sometimes if there is underlying air conditioning or street noise, and you need to filter that out later, then you have a sample of it. Again this plays into classical music being more willing to embrace certain technologies. For instance, when Sonic Solutions first started, they came out with their NoNoise system, suddenly you were able to take out a lot of these room tones, room noise, and audience noise. These things could never be handled before. This also causes a big backlash because when people first started using it they were so enamoured with, "oh I can suck all this *noise* out" — they overdid it. Once people realized what had happened, there came this backlash that NoNoise is terrible and it's not part of the recording art form that we as classical engineers are participating in. It required,

⁴⁵ These sounds are regionally dependent. For instance, EU and the UK uses a utility frequency of 50 Hz, whereas North America uses 60 Hz.

however, a good, competent engineer in order to determine which noise we leave in or out, and how much we take out so it's not compromising the integrity of the recording. That was a whole other issue that was going on at that period of time.

The de-noising process described above requires a sample recording of the *empty* room where the recording took place. This sample recording is known as a *fingerprint*, and it enables an application such as NoNoise, Cedar, or Rx to reduce or remove unnoticed background noise accumulated during recording.⁴⁶ Fitton also explains that completely removing all noise, however, tends to sound unnatural. Many engineers instead consider small amounts of extraneous noise to be part-and-parcel of the listening experience for particular records. *Sound on Sound* writer Paul White agrees with Fitton's statement, and he comments on the importance of certain noises by stating (in White 2012),

In most applications, the complete removal of noise is counterproductive, as it draws attention to the processing and becomes a distraction. In practice, it's usually far more effective and less obvious to use more subtle processing, even if the degree of noise reduction is more modest. Reducing the attenuation range of a gate to, say, 12dB (so it doesn't completely close, but just attenuates by 12dB) usually sounds subjectively better than a hard gate action.

Subtle processing maneuvers are favoured for denoising signals because they sound less distracting overall. The amount of noise removal applied in a given situation depends on the aesthetic demands of the clients, and the record. Thus, mastering engineers are tasked with the final aesthetic judgement regarding what noises, in a broad sense, to target for removal, or the degree to which these noises should be attenuated on the record.

⁴⁶ When engineers record offensive noises for the purpose of removing them from a signal, this process is known as *fingerprinting*. These fingerprints are loaded into a noise-removal software such as Z-noise by Waves. To be clear, Fitton is advocating that engineers provide a recording of the *empty* room where the recording took place. These recordings do not actually contain silence, however, and will instead contain subtle offensive continuous noises that exist within the room. Noises are often covered up by the other sounds present at the time of recording, and this process is known as *masking* (Katz 2007: 140).

In audio example 1.5.2, I demonstrate fingerprint-based de-noising using iZotope's Rx plugin. At first, a noisy drum track plays. Listeners should pay attention to the recurring *crackle* noises that occur in the upper-midrange. After 15s, the track fades out and I apply the de-noising plug-in. At 30s, I intentionally apply too much denoising, and the track's overall depth and spectral characteristics suffer as a result.

Engineers may contribute, remove, and shape noise during other recording processes such as tracking and mixing, but the finalized noise profile of any recording is only established once mastering occurs. This said, even classical recordings include some noise in order to avoid sounding overly *sterile*, and some genres such as indie and hip-hop music cherish noise as a foundational aesthetic component, as I noted before. Thus, generic expectation plays a crucial role in determining the amount of acceptable noise on a record.

Engineers do not make these aesthetic judgements lightly, of course. Although some musical traditions value noise, hiss, and distortion, many others do not. And noise management has taken on a renewed importance in today's record industry, where project studios and other such non-ideal recording environments prevail (Katz 2007: 140; Cousins & Hepworth-Sawyer 2013: 2). In these recording spaces, environmental noise such as air conditioner rumble, airflow noise, and computer fans often mask undesirable noises in one's mix project.⁴⁷ When a project studio features this sort of persistent background noise, it can be difficult for tracking and mixing engineers to identify problems (Katz 2007: 140). Bob

⁴⁷ Masking is a psychoacoustic phenomenon wherein sounds of a similar frequency distribution obfuscate one another. For example, if someone is mixing audio in a room with a loud air conditioner fan, the continuous noise produced by this device may *mask* certain frequency content. (Moore 2013: 67)

Katz describes how noise may accumulate, and go unnoticed, during tracking and mixing (2007: 140):

Consequently, when the mix arrives at the quiet mastering suite, we notice problems that escaped the mix engineer — click track leakage, electrical noises, guitar amp buzz, preamp hiss, or noises made by the musicians during the decay of the song. We use our experience to decide if these are tolerable problems or if they need to be fixed. Hiss which can be traced to a single instrument track is more transparently fixable at mix time; I ask the mix engineer to send me the offending track for cleanup, then return it for a remix. Or I may suggest a remix, bringing his attention to vocal noise between syllables, which can mute. But clients don't always have the luxury or time to remix, and so mastering houses have the most advanced noise reduction tools which affect the surrounding material as little as possible.

As Katz explains, only two *cure-all* solutions exist for de-noising a signal: re-record, or re-mix. Of course, owing to time and budget constraints, clients cannot always provide revised versions of their work, or perhaps the artist or producer cannot access previous versions of the recording. As a result, mastering engineers reconfigure offending noises on records through the development of dedicated tools and methods.

The most important method for treating noise, according to Bob Katz, is to simply ignore the offending noise. As he states (Katz 2007: 140-141),

We engineers tend to forget that the ear has a built-in noise reduction mechanism which gives us the ability to separate signal from noise, and hear information buried within noise. Thus the key to effective noise reduction is not to attempt to remove all the noise, but to accept a small improvement as a victory.

Beyond this, a common strategy for dealing with noise during mastering involves acquiring a *fingerprint* of the offending noise, such as Waves X-Noise, Sonic Studio's NoNoise, or iZotope's Rx. A *fingerprint* is a short recorded sample of a sound deemed to be undesirable within a given signal. These easy-to-use de-noising systems often provide nonideal results for engineers, however, as Katz explains that "ease-of-use is usually (but not always) inversely proportional to effectiveness; consumer programs with their simple setups provide the least satisfactory results" (Katz 2007: 141). Indeed, the most effective de-noising strategies require careful application and training. Paradoxically, some approaches for denoising actually create

offensive noises, that is, they produce short duration *artifacts* during the de-noising process, which many engineers colloquially call *gremlins*. Moreover, when users over-apply a given de-noising method, the depth and perceptual *space* of a recording can disappear along with any spectral information located around the offending noise.

Aside from fingerprint-based denoising solutions, mastering engineers can also use simple equalization as a method for filtering non-continuous hisses and pops. As long as no significant pitch or timbral information is located within the affected region, engineers should be able to filter out offending frequencies for a short moment (i.e., 0-3ms). If a pop song features a hissy electric piano during the introduction, for example, selective equalization could filter out some of the offending noise (Katz 2007: 141). However, if drums factor into the arrangement beyond this introductory section, cymbals — as high-frequency dominant sounds— may *mask* some of this hiss, and thus mastering engineers must decide whether de-noising is even required.

Audio Example

In audio example 1.5.3, I use an EQ to remove a click. The click is heavy in upper midrange and high frequency content, so I briefly apply cuts in these regions (e.g., approximately 3 ms). These spectral modifications occur so quickly that listeners do not find them distracting. The track includes these offensive noises at first (00:00-00:15) before I apply this noise-removal technique (00:15-00:30).

Another common de-noising method targets offensive noises by using multiple selective narrow-band filters. This can be done using Sonic Studio's No-Noise plug-in, for

example. Before filtering noise this way, engineers may perform a spectrum analysis of the noise floor in order to determine what spectral information can be altered without destroying timbral or spatial characteristics (Katz 2007: 142). To accomplish this, engineers can observe what frequency information remains crucial to the record through a frequency analyzer. If the offending noises are not expressed in the signal's important frequency zones (e.g., strong fundamental frequencies and related timbral components), then narrow-band noise filters may be applied. Although, many engineers simply use their ears to identify what spectral region the offending noise occupies instead of a spectrum analyzer.

Mastering engineers also employ a technique known as narrow-band expansion to attenuate or remove noise. Typically, this method treats noises highlighted by the accumulation of compression during earlier phases in the recording process. Compression applied during tracking (and mixing) is often compounded via a number of standard practices, such as buss compression, and this can cause noise to build and accumulate. As Katz explains, "since compression aggravated the noise, expanders are its cure. As little as 1 to 4 dB of [expansion] in a narrow band centered around 3-5 kHz can be very effective" (Katz 2007: 142).

In order to treat noise through expansion, users select a frequency band that contains undesirable sonic artifacts. Although most expanders offer discrete control over several bands, narrow-band expansion uses only one band at a time.⁴⁸ Expanders use similar controls to compressors (which are discussed thoroughly in Chapter 2), although the end result increases a signal's dynamic range rather than reducing it (as compressors do). The most important expansion controls are *threshold*, *ratio*, *attack*, and *release*. A *threshold* control determines the amplitude level that causes the expander to engage. The *ratio* setting determines how much expansion is applied once the threshold is crossed. Dedicated *attack*

⁴⁸ For those attempting to replicate this technique, consider bypassing additional bands (or setting them to a 1:1 ratio; Katz 2007: 142).

and *release* controls determine the length of time it takes for the expander to engage once the amplitude crosses the threshold, as well as how long the expander remains engaged. Once the user specifies a spectral region to adjust (often 2-6kHz), the expander's attack and release controls are set to *fast*, and the expansion ratio is placed at a high level. Engineers proceed to adjust the expander *threshold* value to a level slightly above the level of the noise floor. By using quick attack and release times, a *chatter-like* effect is produced within the targeted frequency band. The presence of this chatter alerts the user that the expander is indeed *expanding* the dynamic range of the selected frequency target (Katz 2007: 142). After this point, the user reduces the expansion ratio (to taste), and the release time is also increased until this audible chattering is reduced. For this to occur, users must specify a *fast* attack time, in addition to applying a feature known as *look-ahead*. A *look-ahead* delay causes the expander to engage approximately 1-10ms before the signal's amplitude triggers the device, and in so doing it helps preserve the signal's audible transient detail (Katz 2007: 142).

Audio Example

In audio 1.5.4, I demonstrate the application of a narrow-band expander to an overly compressed track. In this case, dynamic compression highlighted the presence of noise in the track. Dynamic expansion is thus used to mitigate the prevalence of this noise. A highly compressed track plays (00:00-00:15) before I apply the expander. Listeners will notice the segment with the expander sounds more open and *realistic*, than the highly compressed example.

This narrowband expansion solution only works in situations where compression applied earlier in the recording process produces noise within a given frequency band. However, engineers also address noise through the provision of sophisticated multiband tools for *downwards expansion*. These devices can operate with or without a *fingerprint* of the offending noise. Examples of *fingerprint*-based denoising products include Algorithmix's NoiseFree, Cedar's Denoise, and Sonic Studio's NoNoise. Devices that operate without a fingerprint, on the other hand, include the Weiss DNA1, Cedar DNS1000, and GML 9550. These tools instead isolate noise via a detection algorithm, or by providing the engineer with discrete control over the threshold of a given frequency band (Katz 2007: 143).

Every denoising technique, whether based on dynamic expansion or spectral filtration, also removes a portion of the original programme on which it operates. One such destructive side effect of most denoising techniques is the reduction of ambient detail. In fact, the presence of some noise is necessary for establishing a sense of space on a record. As Gordon Reid of Cedar explains (as quoted in Katz 2007: 144),

The difficulty lies in the fact that reverberation tends to decay to noise. However, much of the directional information and ambience we perceive is from reverberation. Therefore, remove the reverb with the noise, and — in effect — you remove the walls, floor and ceiling from the room.

Listeners expect the reverberant profile of sounds to decay into a *wash* of noise. This expectation results from an individual's memory regarding the behaviour of environmental sounds. In addition, decaying sounds slowly reduce in high frequency content as they move away from the listener (Moore 2013: 279). Thus, after noise reduction occurs, it is common to perform some type of corrective equalization. This is because noise, in general, directs the listener's perceptual awareness of high frequency content (Katz 2007: 144).

Although mastering personnel routinely use de-noising tools, how they use these tools tends to differ. This is because engineers apply denoising processes via phenomenological evaluation, where distracting noises (if present) are identified upon playback. From this point,

the engineer selects the desired method for treatment (e.g., ignore, expand, or filter). Adam Ayan of Gateway Mastering, for instance, offers the following insights on his own de-noising practice (in Hepworth-Sawyer & Hodgson, forthcoming):

I'll start with denoising. I think it's something that happens every day to one extent or another. Denoising, on a daily basis, just means removing some clicks and pops and that sort of thing. Occasionally you get something with a lot of analog hiss and maybe I'll go after that if it's bothersome, but my general rule of thumb with denoising is: if there is something that is not a musical component of the recording, and it takes me out of the moment when I'm listening to it, then I need to address it. That's my threshold for whether or not I need to apply any de-noising strategy and of course, everyone's going to have a different threshold of whether or not it's bothersome or distracting. I'm very comfortable with what my threshold for noise is, and in my day-to-day work that may mean removing a couple of mouth noises or clicks and pops here and there. Naturally, with everyone doing everything in-the-box prior to mastering these days, you occasionally come across some digital clicks and ticks that are probably byproducts of edits done in tracking or mixing. So I'll take those sounds out as well as the stray noises, whether it's a drummer putting their sticks down or a guitar player moving in his seat, in a quiet spot. However, as I said, my threshold for whether I denoise or not depends on whether or not it's taking me out of the musical moment at all. If so, I'll address it.

Here Ayan describes a noise removal strategy that relies on *experience*, where signal processing decisions directly result from his sonic perspective on a given record. This act enshrines Ayan's audile perspective into the master copy.

All modifications made to a record's noise profile stem from an engineer's phenomenological evaluation, as described above. However, these assessments also consider the record's genre. As stated earlier, some noises are simply left untreated because of varying genre expectations. In some cases, a noise may become an endearing feature of the record.

Bob Katz provides one such example by stating (2007: 144):

[We must consider] the client's perspective. I once mastered an album where the opening of a tune had an obvious electrical tic on top of the bass player's note. I removed the tic, restoring the note to its beauty, I thought. But then the producer asked me to restore the tic — demonstrating that many noises are considered to be part of the music. Become familiar with each musical form — sometimes “dirty” is “clean.”

Indeed, crafting an effective noise profile requires familiarity with various genre expectations. For this reason I suggest that de-noising records is not an act of mere quality control, as it is so often described by musicians and scholars, but is a series of aesthetic judgements made by mastering engineers when they structure the signal-to-noise ratio of all records.

Loudness

Mastering engineers also establish another crucial aesthetic property of records: loudness levels. Loudness codification is quite complex, in fact, and most non-engineers incorrectly believe loudness relates to a signal's peak amplitude — a term that instead describes the maximum extent of oscillation within a soundwave. Loudness actually describes a subjective perceptual parameter of records that depends upon the combination of average sound pressure levels (SPL), microdynamic detail, and frequency content (Moore 2012: 133). Thus, adding or removing gain, or simply turning up (or down) the *volume* knob, does not establish a record's loudness profile. Instead, mastering engineers primarily modify a record's loudness level via the application of limiting/compression, EQ, saturation/distortion, and clipping.⁴⁹

Loudness is, perhaps, one of the most pervasively misunderstood components of record playback, and I shall now explain its importance to the art of audio mastering. Terms and evaluative strategies central to loudness perception also receive discussion in this section.

⁴⁹ Mastering engineers are solely responsible for finalizing a record's loudness characteristics. As Mark Cousins and Russ Hepworth-Sawyer explain, "a commercial[ly mastered] release might sound 10dB louder than a mix you've just finished in your studio, even though both audio files peak at 0 dbFS. Mastering engineers implicitly understand the phenomenon and power of loudness, and how to best utilize it as a part of maximizing the potential of the music they work with" (2013: 137). While this point hardly requires clarification for individuals who routinely engage in some form of production practice, I include this information for readers who are new to record production. For more information on how mastering engineers address loudness as a matter of course, please see Cousins & Hepworth-Sawyer (2013), Golding & Hepworth-Sawyer (2009), Hepworth-Sawyer & Hodgson (forthcoming), Hodgson (2010), Katz (2007, 2010, 2014), Owsinski (2008), Shelvock (2012), Waddell (2013), Wyner (2013)

Numerous methods for quantifying loudness exist, and in this section I intend to focus on the measurement methods that mastering engineers use most frequently. As a result, I do not provide an in-depth discussion of *broadcast* recommendations such as EBU R-128, for example (although, it is mentioned). The mastering community at large has not embraced this standard, as it is intended primarily for broadcasting television and radio signals.⁵⁰

Thomas Lund (2011:9) describes loudness as follows: “a perceptual property of sound. Humans rate loudness between quiet and loud. Several physical and psychological factors contribute to the sensation of loudness.” According to available psychoacoustic research, these factors primarily include a signal’s frequency distribution and average level (Moore 2012: 133). While the physical dimensions of loudness are quite easy to measure, psychoacoustic engagement with loudness is more difficult to quantify. Consequently, engineers and researchers have attempted to measure loudness via several different methods. However, even though standards change, every loudness measurement incorporates some form of detection of a signal’s peak levels and RMS (Fielder 1981; ITU-R 2011). Peak amplitude refers to the widest observable oscillation a waveform demonstrates, and RMS is calculated by determining the square root of the squared average amplitude of a signal.⁵¹

⁵⁰ While two well-known mastering engineers discuss the EBU R-128 standard (Katz 2014, Shepherd 2009-14), the majority of engineers continue to use subjective judgements to establish a record’s overall loudness levels.

⁵¹ Although other standard methods are used to describe programme loudness (e.g., LUFS), loudness researcher Programme loudness (measured in LUFS, or LKFS in the past) and RMS levels are often very close in many cases. Perhaps this is because program loudness (LUFS/LKFS) uses RMS calculation as a basis for ascertaining average amplitude (in addition to frequency filtering, called *K-weighting*. ITU-R BS1170-4, Annex 1: 2). Elsewhere, AES-based loudness researchers continue to reference both RMS and DR (Deruty & Tardieu 2014). Thus, RMS is still a highly relevant measurement, and RMS meters continue to be included in many DAWs and analysis suites, such as those offered by Waves, Voxengo, Ableton, Logic, and Wavelab.

Audio example 1.6 illustrates the difference between peak volume and *loudness*. The first segment of this example peaks above 0 dB (00:00-00:15), whereas the second segment peaks at -0.2 dB (00:15-00:30). However, the second segment is much louder than the first, owing to a higher RMS level, and more pronounced high-mid and high frequency content.

One common method for measuring loudness is known as Dynamic Range (DR). A record's DR refers to the difference between its peak amplitude and RMS levels (Shepherd 2009).⁵² This method was introduced in 1981, and was updated numerous times since then (Fielder 1981, AES 1998). While newer standards exist, the entire mastering community has not yet completely forsaken DR measurement.⁵³ As with any new production technology, practitioners do not always quickly adopt the latest set of tools.⁵⁴ This is especially true for

⁵² This is also known as *crest factor*.

⁵³ Ian Shepherd explains that DR meters remain highly relevant despite the availability of other tools (2013): "Is it time to stop using DR values? Maybe the goals of *Dynamic Range Day* and its *Challenge* should be updated to request a minimum "loudness range", LUFS reading or some other metric? I don't think so. Not all albums will have (or need) a wide "loudness range" – we're not trying to stop people making dense, intense music, or creating heavily distorted textures. We just want people to realise they don't have to make their music sound like that in order to "compete". As ITU volume normalisation becomes common-place, we'll be more free than ever to mix and master our music to sound exactly as we like it, and know that people will hear it the way we intended. As I said above, DR values are quick, convenient and familiar."

⁵⁴ While the EBU R-128 standard has been adopted by many broadcasters, it is too early to tell whether mastering engineers will fully adopt it. For example, Roland Löhnbach of Studio Compyfox states in a forum post, "Thing is, EBU R-128 (or ITU 1770-2 for that matter) is just too soft in the long run. It works for broadcast (since the measurement is on a long-term basis), but not for music - unless it's squashed to sh't. [...] I think I've said it before. We (engineers) are engineers, not broadcasters. Two different workbranches." On the KVR audio engineering forums, numerous professional engineers share their reservations about EBU R-128 (please see: <https://www.kvraudio.com/forum/viewtopic.php?p=4935644>.) While forums are generally not ideal for many types of research, they remain one of the few arenas wherein real-world engineers continually engage in public discussion. Until more interviews are collected and published by scholars (such as those found in Hepworth-Sawyer & Hodgson's forthcoming book), forums will remain one of the few methods for reading the opinions of professional engineers of all types. Working professionals can easily be identified on forums via the information contained in their signatures.

mastering engineers who have used other methods of loudness evaluation for many years. Given that all subsequent methods for measuring loudness also incorporate some form of evaluation of a signal's peaks and RMS levels, it is no surprise that some engineers continue to use the DR meter today (Hepworth-Sawyer & Hodgson, forthcoming). However, in general, engineers do not consider visual meters to be as important as their aural evaluations of a signal. This is why available mastering literature discusses ear training at length (Katz 2007, 2010, 2014; Cousins & Hepworth-Sawyer 2013; Hepworth-Sawyer & Hodgson, forthcoming; Hodgson 2010; Owsinski 2008).

Quite recently, between 2010 and 2014, the European Broadcasting Union (EBU) delineated new standards for loudness measurement (EBU R-128) based on *programme loudness*, *loudness range*, and *True-Peak* metering. Programme loudness describes the integrated loudness of a record (or broadcast) throughout its duration, and is measured in Loudness Units Full Scale (LUFS).⁵⁵ LUFS takes into consideration both a signal's RMS, as well as its frequency distribution (or, K-weighting; Lund 2011: 9). Loudness range (LRA), on the other hand, is measured through an evaluation of a signal's RMS level at discrete moments over the running duration of a record. The signal is split into 3-second segments and the RMS for each segment is determined. Once the RMS distribution of these short segments is acquired, the LRA is defined as the difference between the 10th and 95th percentiles within this distribution (Deruty & Tardieu 2014: 43-44). This method ensures statistical outliers are ignored, such as moments of pure silence or instantaneous clipping.

The EBU R-128 standard also incorporates an assessment of a record's True Peaks. True Peak detection allows users to not only detect peaks in individual samples, as traditional peak meters do, but also the peaks that may occur *between* samples. The developer of this detection algorithm, TC Electronic, describes True Peak detection as follows (2015):

⁵⁵ This measurement is identical to older *LKFS* (or, loudness, k-weighted, to full scale).

What sets the true-peak meter apart from sample-peak meters is a special algorithm - donated by TC - that not only looks at the actual samples, but also inter sample peaks. In effect, the true-peak meter can unveil peaks in between actual samples that would otherwise cause distortion. Therefore, a true-peak meter actually 'goes beyond 0 dB'. A reading using a traditional sample-peak meter that displays a max of e.g. -0.2 dB could go as far as +3 dB on a true-peak meter reading.

While the description of loudness offered above seems like a purely technical affair, experts generally agree that no available tool fully quantifies loudness (Cousins & Hepworth-Sawyer 2013: 7). In fact, loudness management on records is a creative endeavor, and a record's loudness profile depends heavily on genre. However, a record's release year, or general era, also determines its loudness profile. In the 1950s, for instance, a culture of competitive release levels formed around the invention of the jukebox. Jukebox machines featured a fixed output level (e.g., patrons could not adjust the overall volume), therefore, a quiet release resists audibility in a crowded bar or diner. Worse yet, a sudden drop in level might discourage dancing or drinking. Labels also noticed the tendency for louder tracks to receive more radio airplay during this time. As a result, record labels happily released loud records in order to draw attention to new releases (Owsinski 2008: 4). As Katz (2007: 168) explains regarding this early *loudness race*, "...In the days of vinyl, mastering engineers competed to produce the loudest record to attract attention in the jukebox, which had a fixed volume control." Bobby Owsinski corroborates Katz's account (in 2008: 4):

Producers and artists began to take notice that certain records would actually sound louder on the radio, and if they played louder, then the general public usually thought they sounded better, so maybe (they were speculating here) the disk sold better as a result.

Labels printed increasingly loud masters in the 1960s in order to compete with one another. This approach is further demonstrated within the Motown catalogue, for instance, as sound engineer Brian Holland recounts (in Wadhams: 2001):

Loudness was a big part of the Motown sound. We used ten, even twenty equalizers on a tune — sometimes two on one instrument, to give it just the right treble sound... a higher intensity. We used equalization to make records clear and clean. We also

used a lot of compressors and limiters, so we could pack the songs full and make them jump out of the radio. We were interested in keeping the levels ‘hot’ on a record — so that our records were louder than everyone else’s. It helped established the Motown sound.... [our] records really jumped out.

As engineers Bob Katz, Bobby Owsinski and Brian Holland suggest, the competitive act of printing so-called *hotter* recordings was a central concern for many record industry personnel in the 1960s and 1970s. However, with the advent of digital audio in the 1980s the industry began to push the limits of programme loudness even further. Eventually, the competition, which began in the Motown era, reached a pinnacle between 1999 and 2004, and has since become known as the *Loudness War* (Deruty & Tardieu 2014: 54).

Beginning in the jukebox era, an upward trend in loudness levels marks the second half of the 20th century. Yet curiously, releases from the 1970s and 80s still maintain a relatively wide dynamic range (DR) compared to today’s releases.⁵⁶ For instance, consider the chart below from loudness-researcher Ian Shepherd’s website (Fig. 1.5). This graphic demonstrates that Justin Bieber’s 2010 pop album *My World 2.0* is paradoxically *louder* than earlier releases by Motorhead and the Sex Pistols (1970s-1980s). To clarify, both Motorhead and the Sex Pistols were once thought to release very loud records, as loud records are a prized feature of hard rock and punk music.⁵⁷ The DR values provided below demonstrate that a greater dynamic range (and a lower loudness level) is measurable on albums by the Sex Pistols (1977) and Motorhead (1986) than on Justin Beiber’s album (2010). Moreover, both

⁵⁶ While DR has been replaced by other more accurate measurements of loudness, it still strongly correlates to human loudness perception (Shepherd 2013). Moreover, RMS and peak levels remain integral components of the updated EBU-R128 recommendations, which incorporate LRA, programme loudness (i.e., LUFS), and True Peak (Camerer 2010:1). Thus, for the purposes of demonstrating decreasing dynamic content since the 1970s and 1980s, DR is an entirely acceptable form of measurement. DR demonstrates the skewed dynamic contours of recent digital releases, even though more concise measurements exist.

⁵⁷ The following *Rolling Stone* interview characterizes the Sex Pistols as a loud band, for “They’re musicians, not philosophers, so they’re probably more interested in making the best possible mythopoeic loud noise than they are in any logical, inverted political scripture.” (Nelson, February 1978)

Sex Pistols and Motorhead albums are loud in comparison to pop releases from the 1970s and 80s.

Figure 1.5

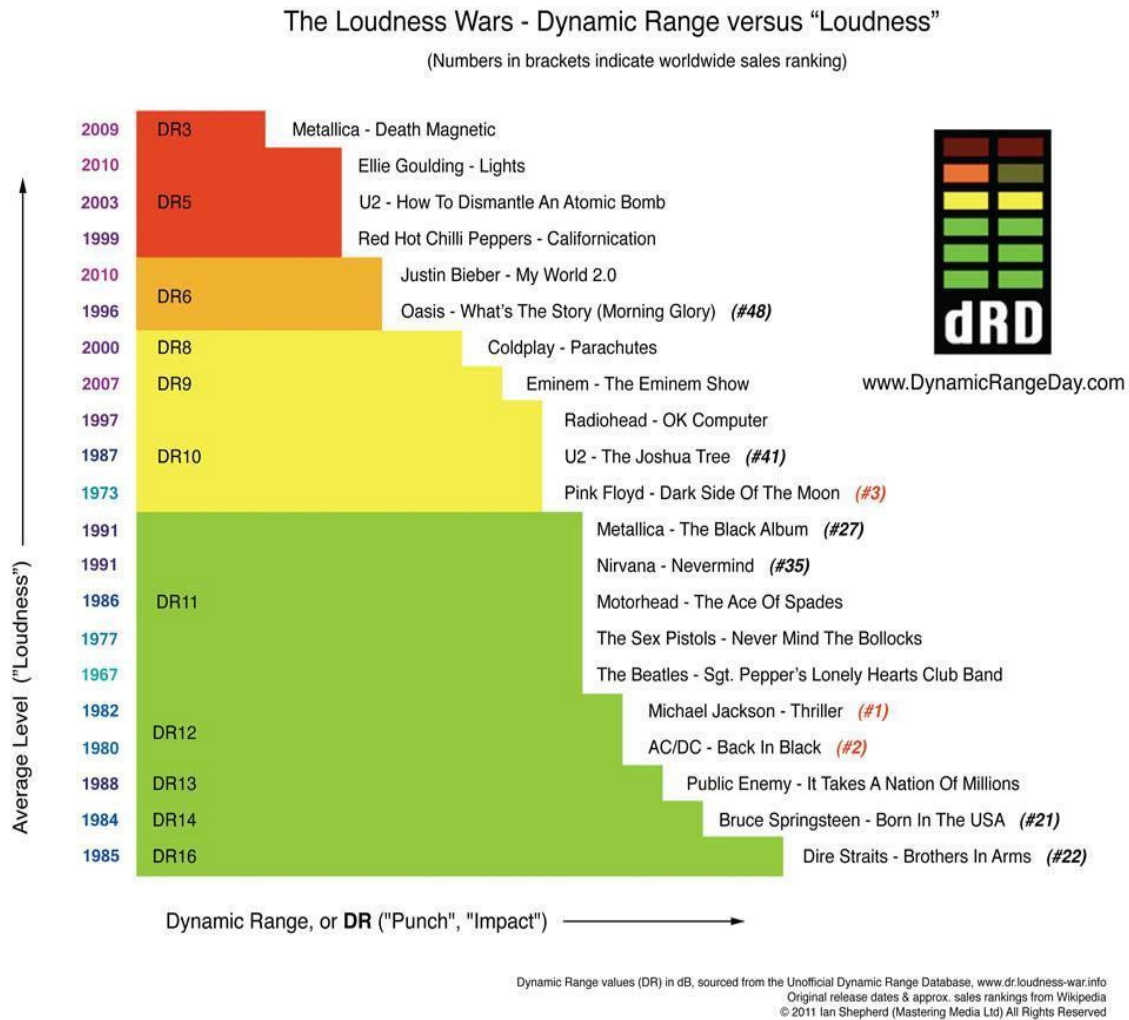

Figure 1.5 provides a summary of DR levels from 1985 to 2010, with a focus on chart-topping material (Shepherd 2011).⁵⁸

⁵⁸ Image sourced from <http://productionadvice.co.uk/loudness-war-infographic/> (Accessed March 19, 2017).

Loudness Wars

The digital recording era marked a new age for loudness management on records.

Researchers and critics usually argue that the adoption of a fixed maximum volume in digital recording systems, called “full scale,” (dBFS) provoked the current Loudness War (Katz 2007: 168). Ray Staff, for example, points out that 0 dBFS — the maximum useable amplitude in digital systems — has become a *goal or target* in the digital recording paradigm (Hepworth-Sawyer 2009: 251). Other mastering engineers lay similar critiques against current *loudness* trends heard in today’s digital releases. Bob Katz, for instance, characterizes the differences in perceived volume of recordings produced during the 1970s versus those produced digitally by stating (2007:169),

In the days of the LP, the variation in intrinsic loudness of pop recordings was much more consistent, perhaps within as little as 4 dB. Even at the peak of the vinyl loudness race, I could put on a Simon and Garfunkel LP, or even a Led Zeppelin, and follow that with an audiophile direct-to-disc recording, barely having to adjust the monitor control to satisfy my ears.

The switch to digital recording did not immediately spur on the Loudness War, however. In fact, early CD levels were initially more comparable to albums heard throughout the vinyl era. Katz continues (Katz 2007: 169):

In the earliest days of compact disc, before the digital loudness race began, many mastering engineers would dub analog tapes with 0 VU set to -20 dBFS, and leave the headroom to the natural crest factor of the recording. It was not thought necessary to peak to full scale, and so the intrinsic loudness of early pop CDs was much more consistent. However, the inventors of the digital system abandoned the VU meter, which opened Pandora’s Box. And so the average level began to move up and up.

While digital recording is routinely demonized for enabling current loudness trends, in the above passage Katz clarifies that early CDs feature a larger dynamic range than later CDs.

Thus, digital technology can only take partial blame for enabling the Loudness War.

Actually, researchers have identified 1994 as the year in which “there was no turning back” from the Loudness War (Milner 2011: 280-81). Famously, Oasis’ (*What’s the Story*) *Morning Glory?* (1995) concretizes this trend. In an interview, mastering engineer Barry Grint (in Hepworth-Sawyer & Hodgson, forthcoming) recalls working on this record:

When I was at Abbey Road, I did the mastering on the early Oasis singles, and they were the band that was going to be louder than anybody else. They were through Creation and Sony, and Ray Staff was working for Sony in London. He phoned me up, because a guy from Sony in America had complained about how much compression was on the masters, but the whole thing was like that. That was Oasis — it was going to be squashed and loud. I see it as an artistic choice, and it’s no different than using a vocoder or echo or any other type of sonic colour. That was what they chose to go with artistically — everybody didn’t have to go and do the same thing. Personally, I feel it’s an equivalent situation to when, for instance, one artist breaks through with a vocoder on the track, and then everybody else putting the vocoder on their track as well. It did, however, kind of feed into this paranoia of not wanting your music to sound quieter than another person’s in a club.

Inasmuch as these loudness concerns rest upon aesthetic judgements, Grint also describes the ensuing paranoia associated with releasing quiet masters. This paranoia hits fever pitch in 1999, a time also known as “the year of the square wave,” wherein a number of excessively loud albums were released including *Californication* by the Red Hot Chili Peppers (1999), *Supernatural* by Santana (1999), and *The Battle of Los Angeles* by Rage Against the Machine (1999; Milner 2011: 280-81).

Before the *Loudness War* reached this “year of the square wave,” Oasis’ top-selling album (1995) ignited a new aesthetic trend in popular records, where record industry personnel began to favour the production of far louder masters than ever before. Many engineers, musicians, and researchers indeed complained about this trend, yet Randy Merrill offers an alternative perspective:

I think certain kinds of music can sound great loud. I think that there's can be a certain visceral quality to it when it's just absolutely smashed. That, to me, is discretionary of course and probably pretty controversial. I do feel like certain kinds of music sound great when they're absolutely pushed to the limit. They cause an emotional reaction that you can't get any other way...It's hard work to try to make a recording loud, while

also retaining its musical properties. I always feel like it's a little bit of a cop out for people to complain about it. Especially mastering engineers saying, "Oh the client is making me make it this loud." It's just cause you haven't figured out how to do it. I'm not saying my stuff is really loud by any stretch but I've heard mastering engineers that are really great that know how to make great sounding loud recordings. They've spent the time and tried everything under the sun from analog to digital to figure out how to do it and make it sound like music. To me, that's an approach that I respect more than just simply stating that loudness is ruining music.

As Merrill explains, loudness is an aesthetic property of records which requires thorough consideration by mastering engineers. He further problematizes engineers and critics who blame loudness trends for "ruining music," and in so doing he suggests that these individuals have not developed a method for effectively cultivating expected loudness levels on records.

Despite the recent demand for loud records, engineers strive to produce masters that consider loudness in balance with other crucial sonic parameters such as spectral configuration, stereo representation, microdynamics, and width/depth. In fact, although critics of the Loudness Wars complain that records have lost all sense of dynamics, empirical research demonstrates that this is not the case. Current records do, in fact, exhibit a smaller *microdynamic* range than past records; yet researchers Deruty and Tardieu (2014) convincingly demonstrate in an AES article that the *macrodynamic* range of popular records remains practically untouched by the Loudness War (in 2014: 54):

While the Loudness War has indeed made mainstream music louder, transients less salient, decreased "natural-ness," macro-dynamics remain practically untouched. In other words, there are still pianissimi and fortissimi in recent mainstream music, a conclusion that we provided in [18] and that was confirmed by [5]. Therefore, the origin for the "ear fatigue" phenomenon that is sometimes associated to modern music [40],[41] does not lie with the absence of musical dynamics. Instead, it may be related to micro-dynamics, but this is a concept that is so poorly defined, that it seems a long way before one can find solid relations between the notion of micro-dynamics, a precise set of audio descriptors, and a well-defined percept.

Micro and macro dynamics are poorly defined in available research, and confusion abounds regarding current dynamic structural trends on records as a result. To clarify,

microdynamics refers to an internal comparison of sonic events, and describes the moment-to-moment difference between a signal's peak and its average amplitude. Macrodynamic, on the other hand, describes longer term variations in loudness throughout a track's running duration (Deruty & Tardieu 2014: 43-44).

Although current popular records are indeed louder and more compressed than past records, numerous releases demonstrate an inconstant *macrodynamic* scheme (i.e., the tendency for musical passages to rise and fall in intensity). In fact, researchers quantifiably demonstrate the presence of such macrodynamic variation on popular records. To do so, they collect data on loudness range (LRA) over the running duration of representative tracks. In other words, the Loudness War hardly altered the macrodynamic structure of popular music, despite the prevalence of contrary claims (Deruty and Tardieu 2014: 54; Deruty 2011: 22-24; Serrà et al 2012). Thus, records released during the Loudness War maintain a dynamic scheme that rises and falls in intensity over time. It is instead the microdynamic characteristics of a recording that are observably diminished within the digital recording paradigm (Vickers 2010: 8).

A recent IEEE article, dramatically entitled "The Future of Music," incorrectly states that modern music lacks all sense of dynamics, for instance (Sreedhar 2007). According to the author, a comparison of two amplitude diagrams from records released in different eras support his claims (Figure 1.6, Figure 1.7). Unfortunately, audio engineering terms and concepts are poorly applied within the article. Writing in 2007, Sreedhar confuses crest factor (CF) with loudness range (LRA), as well as peak level with overall loudness levels. The CF of a signal, for instance, is determined by the ratio of peak values to its RMS value, and does not model human macrodynamic codification; nor does it completely model loudness for that matter (Deruty & Tardieu 2014: 44). LRA, on the other hand, measures loudness range over time, and in so doing more accurately measures a record's macrodynamic scheme.

Figure 1.6



Figure 1.6 is reproduced from Sreedhar (2007). This illustration provides an amplitude diagram of a record from the 1980s/early 1990s.

Figure 1.7

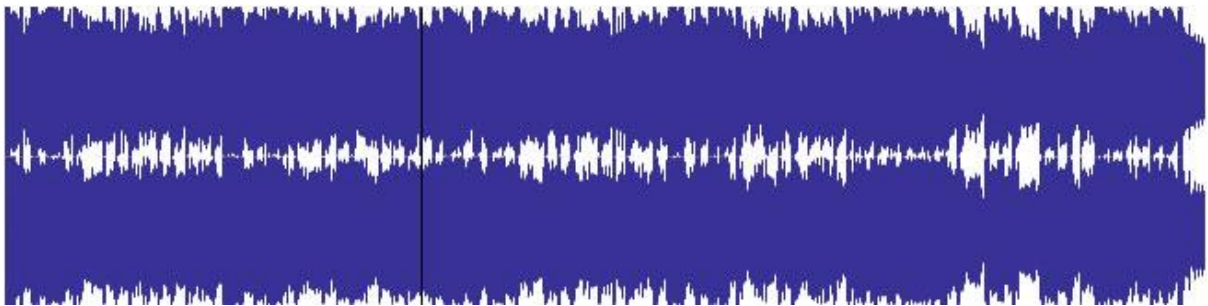

Figure 1.7 is reproduced from Sreedhar (2007). This illustration provides an amplitude diagram of a record from 2007.

Despite the methodological errors present in Sreedhar's loudness research, he is correct in stating that records are now far louder than ever before. In addition, the dynamic profiles heard on popular records is far less *natural* sounding than recordings released in the 1970s and 1980s (Deruty & Tardieu 2014: 54). This audible degradation is often described by experts as *fatiguing*, or *loud*, but these qualities do not relate to a song's macrodynamic structure. Instead, these are microdynamic issues — a term that can be used interchangeably with crest factor (Deruty & Tardieu 2014: 54). It is perhaps this confusion between micro and

macrodynamics that leads some to claim that current records lack *musical* dynamics (e.g., *pianissimo*, *forte*, etc.), while instead providing evidence of a reduced microdynamic structure (Deruty & Tardieu 2014: 54).

Although controversial, researchers Emmanuel Deruty and Damien Tardieu additionally observe that the Loudness War may, in fact, show quantifiable signs of receding. They summarize the history of audio mastering as the confluence of two distinct stages, the second of which ends in 2004. They observe that,

... from 1967 to 1984, mainstream music production tends toward high-fidelity and transparency, thanks to different technological innovations. From 1984 to 2004, on the contrary, it tends toward low-fidelity and transient degradation. This tendency appears to be starting as a purely aesthetic issue, then turns near the end of the 1980s into the Loudness War, in which limiters play a very important role. The Loudness War appears to peak in 2004, and a modest movement toward the opposite direction can be observed (Deruty & Tardieu 2014: 54).

Thus, the distortion and harshness — as well as the lack of microdynamics — associated with overly loud digital mastering may improve if this trend persists. According to the empirical findings of Deruty & Tardieu through an examination of the microdynamic structure of 4,500 tracks, the Loudness War may slowly be approaching an end.

Mastering engineers, while acknowledging that records are certainly louder than 20 years ago, also agree that the Loudness War may have partially diminished. Engineer Bryan Martin comments upon this shift (in Hepworth-Sawyer & Hodgson, forthcoming):

Over the last few years, the Loudness War has declined a little bit. Even still, I would say — and you can ask any mastering engineer — you can't send it back quieter than you got it. Otherwise, you'll have a problem with the label or the artist.

As Martin observes, the record industry may now recognize the detrimental effects of loudness, yet they still want loud masters.

Whether or not the Loudness Wars continue to persist beyond 2004 currently remains uncertain. However, the sonic aftermath of the battle is enshrined within current releases. Engineers typically agree, for instance, that they are still expected to provide much louder

masters than in past eras (Katz 2007: 171). Adam Ayan remarks on these new loudness expectations in the following anecdote (as quoted in Hepworth-Sawyer & Hodgson, forthcoming):

The expectation of how loud something should be in 2015 is so dramatically different than in the late 90s when I first started out. I don't even mind going on record to say that there are expectations of loudness today that would have had you fired from a job 15 or 20 years ago. I don't really complain about loudness that much because it is simply a reality, and the genie is out of the lamp, and it's not going to change that dramatically. Every time we think it's going the other way it doesn't. In fact, it usually goes farther into the realm of loudness.

Ayan demonstrates that loudness indeed remains a central concern for mastering engineers and the recording industry at large. However, if mastering engineers are keenly aware that the quality of records suffer when they are too loud, why do they allow these problems to persist in the first place? In most cases, engineers must take into account a host of factors, such as competitive releases, genre expectations, client retention, and industry standards while mastering records. Consider, for instance, Ayan's account continued from the excerpt above (Hepworth-Sawyer & Hodgson, forthcoming):

My philosophy is that I know my clients are looking for a certain amount of loudness, and I know that's very important to them. I also know that if I don't do it, I won't get the gig and they won't work with me — that's just a fact. So I know they want that, but the challenge that's posed to me is now: how do I establish that loudness and how I make it also sound musical? As a mastering engineer, that's not the easiest thing to do because it takes a lot of finesse and hard work. I mean, it'd be one thing if you could just say, "well I can just push it through more compressors or distort the thing more or whatever," and use these heavy-handed methods that achieve loudness in a very non-musical way. But, that's not what I'm in business for, and that's not what I want to do with recorded music. So I take it as a really serious challenge to attain the kind of loudness that's expected today in 2015, but to do it in the most musical way possible.

Indeed, mastering engineers are expected to establish competitively loud average levels as a crucial part of the job. Ayan, for instance, seems to enjoy the challenge of creating masters

that sound both *loud* and *musical*. And, of course, he must produce loud masters for the sake of retaining clients.

While music researchers do not formally recognize this as an aesthetic concern, programme loudness reveals important information regarding release era and genre. Moreover, loudness strategies change based on the music receiving treatment, as Ayan, Merrill, and Grint explain above. Classical music producers, for instance, sometimes cherish macrodynamics to the point that records are difficult to master. Classical mastering engineer Paul Bailey explains (Hepworth-Sawyer & Hodgson, forthcoming):

We have the opposite problem in the classical music world. I was doing a recording of a larger symphony with an EMI producer, for example, and the whole thing starts soft, with the double basses playing pianissimo. The way they were playing gave us about -50 DBs of headroom. The producer was sitting there saying, “fantastic! You have to listen really hard to hear it, isn’t that wonderful?” Then of course 3 minutes later, BANG. If you set your levels for the opening you’re either going to blow up your speakers or you’re going to blow up your ears. A happy medium for dynamic range needs to be found.⁵⁹

Thus, as Bailey encapsulates, current loudness approaches range from overly quiet to overly loud, and engineers adopt a loudness strategy based on the aesthetic requirements of the programme itself. Far more than a mere quality control measure, loudness management embodies a crucial species of recorded musical communication, and one area where the mastering engineer’s peculiar musical contributions are valued above anyone else’s on the project.

⁵⁹ Many people who listen to classical records typically do so in quiet environments, and they also often use audiophile equipment. For this reason many listeners appreciate the increased dynamic range featured on classical records. Baily’s comments, as a professional classical mastering engineer, are directed towards the overly large dynamic range heard on some digitally released classical records. Instead of suggesting that classical records should feature a similar dynamic range to pop/rock records, he merely states his opinion that a few producers have been over-emphasizing dynamic range on classical (or related) recordings lately.

Evaluating Records: Ear Training, and Sonic Orientation

The musical competencies of audio mastering discussed thus far (i.e., the management of a record's stereo representation, noise characteristics, and loudness levels) cannot occur via the arbitrary operation of professional machinery. Above all, mastering engineers evaluate and shape a record's disparate sonic parameters using a personalized aesthetic rubric, and in order to develop the perceptual skills to perform these assessments, they engage in either formal or informal training. Broadly speaking, most artistic practices involve a degree of skill-development such as this, and audio mastering is not unique in this regard.

For both conservatory-trained musicians and audio engineers, ear training practices develop one's ability to recognize sonic artifacts aurally. In the same way that lower-year undergraduate music students learn to aurally identify important harmonic relationships, audio engineers also develop a keen aural sense regarding the sonic materials they assess. Indeed, recordists learn to identify a waveform's physical properties by ear, such as the sound of various frequency components, amplitude compression characteristics, phase coherency (in stereo signals), distortion levels, noise characteristics, and ambience profile. Students even report feeling fatigued after focusing on these sonic instances for too long — a common symptom of the traditional identification exercises instrumentalists and vocalists perform. Inasmuch as these two methods are similar, aural skill development in audio engineering directly informs the creation of records.

Although engineers must possess the ability to assess a sound's material characteristics, these evaluative skills are difficult to develop. By the same token, traditionally valued musical constructions such as intervals and inversions also resist simple recognition, but these sonorities are efficiently modelled using standard notation. No such visual representation communicates a record's sonic properties such as stereo correlation,

timbral contour, or dynamic profile, for example, as accurately as standard notation models pitches and harmonies.

Although audio engineers certainly use tools to monitor the sonic characteristics of a waveform, no device models sound on a comprehensive basis. VU meters, correlation meters, loudness meters, spectral analyzers, and other measuring devices, for example, each provide an incomplete assessment of one material component of a sound. In fact, the subject of metering is contentious among mastering engineers. Hodgson and Hepworth-Sawyer (forthcoming) elucidate these controversies:

Many mastering engineers blame the rejection of VU for digital meters, which use a full-scale weighting, for the general pulverizing dynamic ranges took during the heyday of the Loudness Wars in the early- and middle-2000s. Some engineers consider overdependence on metering yet another symptom of the overt ocularcentrism that has overtaken modern record production. Producers now work on computers and spend most of their time staring at computer screens, critics complain. Thus, they trust visual more than audible information, and work accordingly.

As these researchers encapsulate, many engineers blame visual metering for causing the *loudness war*, as well as other audible deficiencies currently plaguing records. Instead of relying on meters, many engineers advocate that recordists should learn to trust their own hearing. Engineer Nick Watson contends that an over-reliance on metering may even be detrimental to the development of one's aural skill (as quoted in Hepworth-Sawyer & Hodgson, forthcoming):

What I'm saying is: if you're watching the meter all the time, you're relying on a visual read-out instead of listening to the sound. The meter is always going to have a degree of influence on how you perceive what you're doing, and how you process incoming information. The situation occasionally arises, for example, where my meters are telling me something completely different than to what my ears are telling me.

Indeed, as Watson demonstrates, technological methods for sonic evaluation occasionally provide erroneous data. Although empirically accurate, the information visual meters provide

may not be aesthetically meaningful. In many cases these meters may fail to collect data on the aspect of the record (or signal) receiving attention by the engineer.

Engineers certainly advocate that one's ability to evaluate sound without the aid of visual meters is foundational to the craft. However, meters are still routinely used to confirm aural assessments. John Dent, for example, is an outspoken proponent of the VU meter (in Hepworth-Sawyer & Hodgson, forthcoming):

I suppose from a monitoring point of view, I've got a set of VUs here, which are linked to the output of my Sonic System computer. I do actually study the VUs. I will look at the way the sound is on the VUs and see where things peak to. It's quite interesting because all CDs within reason are peaking at around zero [on the VU meter]. The sounds people generally like and want are visually obvious on the VUs. They behave in a certain way. It's something that I kind of got used to over the years, and I will always study what's going on, on the VU.

While Dent hardly recommends that the VU meter can substantively replace *listening* to audio during mastering, he demonstrates that VU metering can be used to confirm one's aural evaluation of a sound's general loudness characteristics. In addition, commercially accepted loudness profiles tend to display similar VU readings.

Sonic evaluation, whether aural or visual (i.e., VU meters), is crucial to the art of mastering, because an engineer creates value for potential clients by accurately identifying a waveform's physical properties, and by altering these properties to sound subjectively *better* than before. Once a record is finished, the finalized copy, or master recording, reproduces the sonic perspective of the individual who mastered this audio. As music production researcher Jay Hodgson puts it (2014: 36- 41):

Each psychoacoustic profile on a record combines to form a broader, more global, aural perspective— “a hypothetical auditor,” as it were—for the record. It is from this hypothetical auditor's spatiotemporal vantage that every recorded sound is conveyed to listeners, in fact...As with perspectival painting, the broader global aural perspective a record construes—let's call it a mix—simply cannot be moved, modified, or superseded.

The combined psychoacoustic profiles Hodgson discusses are finalized during a record's mastering phase. Audio mastering thus creates a singular "hypothetical auditor."

The establishment of such a hypothetical auditor requires attention to the sonic parameters covered in this chapter (e.g., spectral distribution, stereo design, noise floor, and loudness profile), as well as in Chapters 2 and 3. Those who do not possess this requisite aural acuity cannot engineer or master audio successfully, because the work of recordists is psychoacoustic in nature. Every sonic alteration a recording engineer performs also requires the direct consideration of an audio source, and this requires constant assessment (and reassessment) on the part of the engineer. However, unlike the development of traditional musicianship skills, no standard notational method prescribes or instructs audio mastering. Engineers instead consider the following factors when imparting their sonic perspective upon a project: (i) the psychoacoustic boundaries of human hearing, (ii) the physical limitations of the media format, (iii) the physical limitations of playback technology, (iv) the dominant sonic characteristic espoused on comparable records, and (v) the communicative intent of the artist(s) and/or project at hand. By adopting these five criteria as a rubric, engineers consider, and reconsider, a client's project while applying various signal processing methods, and perhaps other forms of sonic alteration.

Assessing Records

In order to assess a record via the strategy provided above, one must learn to recognize the material properties of sound by ear. In fact, many lauded mastering engineers and educators comment on the need to develop one's facility in *listening* (Katz 2007: 12; Cousins & Hepworth-Sawyer 2013: 48). For instance, Bob Katz explains this requirement for refined aural skills by stating, "mastering engineers lend an objective, experienced ear; we are familiar with what can go wrong technically and esthetically" (Katz 2007: 12). Famed

mastering engineer Bernie Grundman (Prince, Dr. Dre, No Doubt) echoes Katz (as quoted in Owsinski 2008: 7):

Most people need a mastering engineer to bring a certain amount of objectivity to their mix, plus a certain amount of experience. If you (the mastering engineer) have been in the business a while, you've listened to a lot of material, and you've probably heard what really great recordings of any type of music sound like. So in your mind you immediately compare it to the best ones you've ever heard. You know, the ones that really got you excited and created the kind of effect that producers are looking for. If it doesn't meet that ideal, you try to manipulate the sound in such a way as to make it as exciting and effective a musical experience as you've ever had with that kind of music.

In this passage, Grundman reinforces the need for refining one's aural sense to model the sonic characteristics of familiar records. Indeed, a major factor that shapes the creation of new masters is the general sound ideals heard on other cherished records. Engineers learn to recognize and assess such sonic constructions by deepening their perceptual abilities through some form of ear training. This practice involves, in part, developing the ability to decipher aurally spectral configuration, loudness profile, dynamic contour, stereo design, and noise distribution, as it exists on other available records. Engineers must also possess the ability to imagine what sound-shaping methods can produce these sonic outcomes. To summarize, engineers refine their hearing in order to perform the following tasks: establish a perceptual benchmark for overall *quality*; switch between a macro and microcosmic focus on the music in question; and assess the frequency spectrum, dynamic range, width/depth, noise floor, and loudness profile of a recording (Cousins & Hepworth-Sawyer 2013: 48).

Ear Training and Listening Focus

Whether ear training occurs via an intentional approach, or naturally through experience, it is an essential component of a recordist's skill development (Cousins & Hepworth Sawyer 2013: 48). According to Glenn Meadows (in Owsinski 2008: 6), "the reason people come to a mastering engineer is to gain that mastering engineer's anchor into what they hear and how

they hear it and the ability to get that stuff sounding right to the outside world.” And, indeed, clients select mastering engineers based on their perceptual mastery of the nebulous sonic components heard on records.

Recordists may perform a variety of exercises to develop the expertise Meadows describes. A common drill involves alternating one’s attention between general and specific sonic elements on released recordings. Russ Hepworth-Sawyer and Craig Golding suggest in *What is Music Production?* (2011) that amateur recordists adopt this evaluative approach: listen to records *holistically*, and with both a *macro* and *micro* focus. A holistic listening mode considers the sonic impression of the album as a whole. This includes internalizing an album’s psychophysical qualities, such as its spectral balance, dynamic scheme, and perceived loudness, as well as the order of songs, segues, and the length of silence between tracks. A holistic approach to listening considers all these aspects from a global viewpoint in order to discern a record’s overall aesthetic, and in so doing emulates how skilled mastering engineers actually work on records. Thus, this type of training aids the development of critical listening skills by analyzing the work of other mastering engineers.

Further training strategies include adopting the vantage point of the listener. Indeed, listeners may engage passively or actively with a given recording, and engineers consider both engagement styles (Cousins & Hepworth Sawyer 2013: 44). For example, an active listener may be a musician, or someone with a vested interest in the critical analysis of music. Or, they may be fans who ritualistically listen to a record repeatedly, and in so doing intimately acquaint themselves with the minutia of a record’s sonic palette.

A passive listener, on the other hand, is perhaps best described as an individual who listens to music while cooking, cleaning, driving, or doing something other than listening in a concentrated manner. In this case, the record receives less direct attention, yet mastering engineers must still account for this sort of listener engagement. When people listen

passively, much of a record's sonic minutia is ignored. As such, engineers take great care to ensure that a record's main features — whether they are vocal hooks, recurring melodies, or another feature of sonic interest — are communicated clearly to the listener. Engineers learn to switch between passive and active listening to accommodate all reception styles. To reference a popular analogy, they practice recognizing both the *forest* and the *trees*.

Related to the concept of active and passive listening, engineer/researchers Mark Cousins and Russ Hepworth-Sawyer advocate that engineers should practice switching between a macro and micro focus while listening to records. Macro focus refers to a consideration of the general sonic impression left by an individual track. Whereas holistic listening considers an entire album, macro-listening considers the general characteristics of a single track within an album (Cousins & Hepworth-Sawyer 2013: 45). When a mastering engineer is considering the mix of a particular track, she or he is viewing the music from a macro perspective. Micro focus, on the other hand, considers small aural details of a mix. The ability of the mastering engineer to focus on one element of a faulty mix provides an example of micro focus. To use a well-known example, Norman Smith recalls difficulties in balancing the bass guitar in the Beatles EMI recordings (in Kehew & Ryan 2008: 399):

We were sort of restricted. The material had to be transferred from tape onto acetate, and therefore certain frequencies were very difficult for the cutter to get onto disc. I mean, if we did, for instance, slam on a lot of bass, it would only be a problem when it got up to the cutting room... Paul [McCartney] used to have a go at me for not getting enough bass on record. During mixing he'd always say "Norman, a bit more bass?" And I'd say, I can't give you more bass, Paul. You know why — I'll put it on there, but as soon as it gets upstairs into the cutting room [EMI's mastering team] will slash it.....because they thought the needle would jump."

This context — where a mastering engineer focuses attention on an individual element— is an example of the application of a micro focal approach.

Engineers can practice switching between these three modes of listening— holistic, macro-focus, and micro-focus — as a way of conditioning their perceptual faculties to

establish stronger sonic impressions in their work. Russ Hepworth-Sawyer and Mark Cousins ask budding engineers to consider the following when evaluating music:

Is it the vocal hook that has gained your attention, or is it a culmination of a number of factors? Try listening to the music both objectively and subjectively, and then trying to remain in a macro state listening to everything at the same time, perceiving levels all at the same time in different frequency bands, then in micro focusing on a particular element (without the ability to solo it!). (2013: 46)

Indeed, one must constantly switch between these focal points while working on a record in order to ensure a unified sonic aesthetic. However, in the above quote Cousins and Hepworth-Sawyer suggest that budding engineers should also perform this exercise while listening to other available records. By doing this, one can internalize spectral and dynamic balances that have effectively been “peer reviewed” by the industry.

Benchmarking and *Quality*

In addition to developing the ability to switch between holistic and macro/micro foci, mastering engineers should also establish an *internal quality benchmark* as a conceptual reference point for future projects. New monitors and unfamiliar rooms can be particularly troublesome for engineers in this regard, as both affect frequency content. As a result, it is essential for engineers to develop personalized criteria for sonic comparison. Engineers Hepworth-Sawyer and Cousins remark on this phenomenon (2013: 41):

In any audio work, whether that be recording, mixing or mastering, it is important to understand what you hear. The monitors you use can of course colour the sound give you a slanted view of the audio you’re hearing. The same slanted view can be affected by the room in which you’re listening and numerous other areas such as your convertors.

Indeed, room mode and monitor topology can gravely impact the aesthetic decisions mastering engineers make. However, high-quality neutral monitoring systems and well-designed rooms are prohibitively priced. If one establishes a quality benchmark using available equipment, it should provide a point of reference that allows a greater

understanding of how that equipment treats audio. For example, monitors with ribbon tweeters may be used in place of a higher quality alternative in a project-based mastering studio. Ribbon tweeters produce clear, almost harsh, high-end frequency content and transient detail; and if an engineer performs benchmarking to discern this bias, it can be accounted for in all future work. As a matter of fact, an engineer might take advantage of this frequency bias when working on projects intended for digital distribution. Most digitally-released music is heard on headphones, for example, which also notoriously feature a harsh high-end frequency bias. Thus, engineers working on monitors with a similar frequency bias may be able to create masters that better serve the intended listening audience.

In order for such benchmarking to occur, recordists must expand their perceptual capabilities through ear training. Bob Katz delineates two further types of ear training: passive and active (2007: 46). Passive ear training occurs when engineers make assessments away from the console. For example, when an individual notices that a PA system features very *tinny* sounding speakers at a bar, she or he is engaging in passive ear training. Active ear training occurs when engineers connect a sound-shaping technique, such as EQ with a predetermined sound characteristic. To actively improve one's ears, individuals can listen to pink noise while using a graphic EQ to sweep through the frequency spectrum (as demonstrated in Audio Example 1.7). This task should be repeated until the operator can recognize each frequency range. Once an individual can discern these frequency ranges using pink noise, she or he can proceed to perform the same exercise on pre-recorded music (Katz 2007: 74). This approach allows engineers to simulate real-world applications for equalization by filtering complex acoustic signals, and in so doing this gives them an intuitive understanding of equalizer operation and frequency distribution.

In audio example 1.7, I demonstrate boosts of roughly 3dB moving up and down the audible spectrum. Pink noise plays, and boosts and cuts are applied in order to clarify the sound of the EQ actively filtering and boosting frequencies. Audio engineers do this; that is, they *sweep* through pink noise, to learn to identify the various regions of the audible spectrum.

After developing the ability to recognize different frequency ranges, students of audio mastering should next learn to recognize when a program is bandwidth-limited (Katz 2007:

47). Bob Katz maintains (2007: 47-8):

Less - expensive loudspeakers usually have a narrower bandwidth, as do lower-quality media and low sample rates (eg. the 22.05 kHz audio files often used in computers). Train your ears to recognize when a program is either naturally extended or bandwidth-limited. It's surprising how much low and high end filtering we can get away with, as can be heard when old films with optical sound tracks are shown on TV. The listener may not notice the voice is very thin-sounding until it's been pointed out because the ear tends to supply missing bass fundamentals when it hears the harmonics. We can take advantage of this in mastering (ie. reduce the low frequencies to obtain a higher level), but this is an audible compromise and the best productions are always the ones with full bandwidth.

In order to practice recognizing a signal's bandwidth characteristics, one can simply apply high and low pass filters to a recording, and take note of the sonic results. Through training the ear to recognize the attenuation of high and low end frequencies in this way, listeners also acquire skill in assessing a record's overall bandwidth.

Although evaluating spectral distribution is crucial to audio mastering, engineers must also recognize other sonic minutiae. Katz recommends, for instance, that new mastering engineers learn to identify comb filtering. Comb filtering can occur during tracking if multiple microphones capture a single sound source from different angles or distances.

During mixing, on the other hand, comb filtering may result from blending a source and its delayed replica (Katz 2007: 48). This common error occurs as a result of the two audio sources being *out of phase* with one another. Two signals with identical frequency content are *in phase* when they start concurrently, and each signal's spectrum transforms uniformly over time. When this occurs, signal voltage doubles, and this phenomenon is called *summing*. When two combined signals are *out of phase*, or when two identical signals are offset by a short delay, *comb filtering* results. At times, however, comb filtering may also be a desirable effect, as the signal processing technique known as *flanging* makes use of this phenomena (Katz 2007: 48).⁶⁰ In order to discern whether or not such comb filtering is desirable, engineers train their ears to recognize when artifacts such as these are intentional or accidental.

Audio Example

Audio example 1.8 demonstrates the undesirable stereo-field effect known as comb filtering. At first, the track plays with this deficiency. At 15s (00:15), I alter the phase alignment to reduce comb filtering.

⁶⁰ Flanging is an effect used by electric guitarists and bassists, as well as recordists. *Sound on Sound* writer Steve Howell (2006) explains, “The term 'flanging' comes from the original technique of using two synchronised tape machines playing back identical audio — during playback, the flange (or rim or outer edge) of one of the tape machine's reels would be obstructed in some way — slight pressure applied with the operator's finger to the reel, for example — so that one tape machine was delayed ever so slightly for a brief moment and then, as the 'obstructed' tape machine gradually got back in sync with the other, you'd hear 'that sound'.” The sonic result of flanging imbues a sound source with a sort of *swooshing* sound.

Katz also suggests that engineers learn to identify a number of other common recording errors beyond comb filtering, such as *clipping*, issues with stereo spatialization, *dropouts*, so-called *space monkeys* (ie. artifacts of lossy digital compression codecs), skewed analog tape, compression *pumping*, *hiss*, different frequency ranges of sibilance, phasing, noise reduction misalignment, electrical noises, and phonograph-associated noises in vinyl releases (2007: 49-50). A key practice within audio mastering is the identification of errors such as these, followed by the removal of these undesirable sounds through filtering, noise reduction, or in some cases, by re-mixing or re-recording the source material. Engineers can learn to identify these problems by simulating them, where possible, using available equipment. Compression pumping, for example, is easily recreated. To do so, one can simply over-compress a given signal. In addition, engineers can spend time testing the sonic results of various digital data compression algorithms by exporting music using various available formats, or by using a codec emulator, such as Sonnox's *Fraunhofer Pro-Codec* (2007:49-50). Katz suggests that engineers should gain familiarity with "good" recorded sound in all genres, and continues to advocate the following approach to "ear-orientation" (in 2007: 49):

Start by becoming familiar with great recordings made with purist mike techniques, and with little or no equalization or compression. Learn what wide dynamic range and clear transients sound like, so as to recognize more quickly when dynamic range has been limited. Listen to live music; the percussive impact of a real live big band, or the clear transients of a classical piano, which provide a standard that can never be bettered. Compare the depth of a live recital which can be captured with simple miking techniques, versus how much of this is lost when multiple miking is used.

Thus, ear-training for mastering engineers occurs both passively and actively throughout one's entire life. According to the perspectives of several of the world's most celebrated mastering engineers, those who are new to the craft should embrace both types of aural training. It is simply not enough to recognize wow and flutter artifacts, for instance. Instead, mastering engineers should possess an ability to identify these errors and also to

determine whether or not they detract from the musical experience of the record. In other words, mastering engineers must learn to listen as both experts as well as non-experts.

Chapter Two

Dynamic Configuration

Audio mastering engineers finalize a record's dynamic contours before delivering the *master copy* to clients and distributors. To do this, engineers engage in a process known as dynamic range compression (DRC).⁶¹ Mark Cousins and Russ Hepworth-Sawyer comment on the importance of DRC (2013: 58):

While it would be nice to think that all finished mixes are presented with a polished dynamic structure, it's often the case that compression, in some shape or form, needs to be used to shape dynamic structure in some way. To shape dynamics, a mastering engineer can turn to a range of different tools: from analogue Variable-MU devices used from the earliest days of recording, right through the latest multiband compressors that can re-shape a master in some radical ways. Understanding where and how to employ these processors, therefore, is essential in controlling dynamics in a way that is most empathetic to the music you're trying to process.

Indeed, all DRC applied during mastering should remain *empathetic* to the client's aesthetic vision (Cousins & Hepworth-Sawyer, 2013: 58). In other words, the application of DRC offers more than just a simple *technical support* for a record's harmonic and melodic content — it is a crucial component of that content. It is impossible to hear a record without also hearing the dynamic scheme mastering personnel establish. In fact, as this chapter will demonstrate, the application of DRC to a record is a thoroughly creative aspect of music production. By providing records with DRC, mastering engineers thus re-shape both the micro and macro dynamic structure of all recordings.⁶²

⁶¹ Regardless of genre, it is common practice to use a limiter, a form of DRC, to prevent crossing 0 dbFS in digital mixing and mastering.

⁶² These terms are discussed thoroughly in the previous chapters (Loudness Wars). To aid readers with these commonly misunderstood terms, I define them again in this section: *Macro-dynamics* refers to changes in overall loudness as a record plays (Katz 2007: 113). For example, choruses are often much louder than verses on typical pop records (Cousins & Hepworth-Sawyer 2013: 150). On the other hand, defining (or assessing) micro-dynamics is the topic of numerous Audio Engineering Society papers. Although more precise methods for measuring micro-dynamics are currently being explored by researchers and engineers, it is generally agreed upon that micro-dynamics can be assessed by

In this chapter, I analyze methods mastering engineers use to establish the dynamic envelope of a record, and I survey the general operational principles of DRC equipment. I then I elucidate the design features of commonly used compressor circuit topologies, explaining how engineers use different compressor types to produce different sonic results. After this, I discuss the musical ramifications of specific compression strategies to explain how mastering engineers engage in DRC for both *musical* and technical reasons.

Compressor Controls

Compressors and limiters act as automatic gain-controlling devices, and share a number of operational features. Hence, I use the word *compressor* when discussing the general characteristics of these DRC devices. The primary technical difference between the two types is the provision of a fixed ratio (often 10:1 or ∞ :1) when limiting a signal. Apart from this, compressors and limiters are technologically quite similar. However, these DRC techniques are generally used for different signal processing purposes when mastering records, and I discuss the various practical applications of each device later in this chapter (in “Compression Methods and Approaches”).

When applying compression to a signal, engineers typically begin by considering a parameter known as the *threshold* value. When a signal’s amplitude crosses this threshold, the compressor automatically attenuates the signal’s gain. An additional parameter, known as *ratio*, determines the amount of amplitude reduction the compressor applies. A 3:1 ratio produces a signal, which instead of exceeding the designated threshold by 3 dB, will surpass it by only 1 dB. In some cases, where simple attenuation is the goal, recordists may be satisfied with this dynamic alteration and simply move on.

comparing a track’s peak level to its RMS level (also known as *crest factor*). The Pleazurize Music Foundation developed the TT Meter, for instance, to assess a track’s microdynamic scheme, using crest factor as its main evaluative criteria (Skovenborg, 2014: 5; Deruty & Tardieu, 2014: 43).

However, depending on the purpose for applying gain reduction, additional *make-up gain* can be applied to recover the lost amplitude. This additional *make-up gain* raises the average amplitude of the signal. Engineers often use compression this way in order to raise a track's RMS level, or what some researchers call a track's *body* characteristics (Cousins & Hepworth-Sawyer, 2013: 69). For example, if 2 dB of attenuation is applied to the signal, the compressor could apply 2 dB of *make-up gain* as the signal leaves the device's main output stage. This boost occurs *after* the initial gain reduction has occurred, and raises the signal's average amplitude by a full 2 dB.

In addition to threshold and ratio, a number of other settings control the behaviour of a compressor as it engages and disengages. *Attack* and *release* parameters establish *how quickly* and for *how long* the compressor attenuates a signal once the threshold is crossed. For example, once triggered, a compressor can begin attenuating the signal immediately, or after a user-designated delay (often set in milliseconds).⁶³ Simply put, *attack* controls the length of time it takes for attenuation to occur once the threshold is surpassed, whereas *release* determines the length of time the compressor remains engaged.

Slow attack settings are necessary for music with loud transients. When mastering hip hop or EDM, for example, the kick drum often provides the largest transient within a mix (Shelvock 2017: 177). If basic compression is applied with a fast attack setting, the segments where the kick drum plays will be more compressed than moments when the kick drum is silent. Unfortunately, this approach may negatively affect the intended dynamic scheme of the client's work, especially since these genres favour a loud and consistent kick drum (Izhaki 2008: 65; Shelvock 2017: 176-8). In most cases, a better option would be to use

⁶³ Different compressor circuit topologies handle this interaction in unique ways. While one circuit, for instance, may have a programmed attack time of 20ms, it may not actually turn on within 20ms. In other cases, particularly where digital plug-ins are concerned, this number may be quite accurate.

medium-to-slow attack settings to allow the kick drum's transient to occur before compression is applied. This approach conforms to the genre's expected dynamic tendencies.

Release, on the other hand, controls how quickly the compressor shuts off after the threshold is crossed, and fast release times tend to sound less *natural* than slower ones (Cousins & Hepworth-Sawyer 2013: 61). Imagine, for instance, a signal that receives 5 dB of attenuation via compression. If the device's gain reduction mechanism disengages too quickly, the resulting audio will feature odd fluctuations in amplitude. This type of quick release compression causes an effect known as *pumping*. In some cases, such as in EDM music and experimental hip hop, pumping may be a desirable sonic effect (Hodgson 2011; Shelvock 2017: 179). However, this artifact is rarely desirable in other musical circumstances — especially at the mastering stage (Izhaki 2008: 269). More frequently, medium-to-long release settings are used during mastering. Along these lines, many compressors provide an *auto-release* feature, and this setting can be quite useful when processing a full mix (Cousins & Hepworth-Sawyer 2013: 62). Auto-release in DRC refers to an adaptive release setting, wherein release times follow the constantly changing dynamic level of the signal input. Generally, the loudest parts of a signal are more heavily compressed than the quieter components when this feature is engaged (Robjohns 2014).

Another parameter that alters the expression of DRC in a signal is called *knee*. Where attack and release times specify *how quickly* and for *how long* a compressor engages, *knee* specifies how the compressor behaves once the threshold amplitude is crossed. A *soft* knee setting causes the compressor's ratio to increase to its full value gradually over the course of milliseconds (or perhaps microseconds) once triggered. In so doing, a soft knee facilitates a *smoother* transition between the compressor's *on* and *off* states. When users specify a *hard* knee, on the other hand, compressors quickly transition from an inactive to an active state, and the resulting DRC sounds more abrupt (Figure 2.1.1).

Figure 2.1.1 Logic X Compressor



Figure 2.1.1 demonstrates the native compressor packaged with Logic X. Threshold, ratio, attack, release, and knee controls are indicated via arrows.

Whether analog or digital, all compressors use a *sidechain* to monitor and control incoming audio signals. The sidechain can monitor audio according to one of two approaches (and some devices allow users to switch between them): peak detection or root mean squared (RMS) detection.⁶⁴ Peak detection refers to a process whereby audio is attenuated according to incoming signal peaks. If a compressor's threshold is set to -10 dB, and the audio passes -10 dB for any duration of time, then the compressor will engage. Conversely, RMS detection better models human loudness perception, and thus detects signal based on its average amplitude. As a result, when RMS detection is engaged, sounds that only briefly cross the

⁶⁴ RMS is discussed in the previous chapter in the section titled "Loudness."

specified threshold do not receive the same level of attenuation as they would if peak detection were selected.

Limiting refers to compression at a high a ratio, typically above 10:1 (Robjohns 2007). Although compressors and limiters both apply gain reduction based on a threshold value, each device is used for different purposes in a mastering studio. For example, limiters are typically placed at the end of a signal chain in order to ensure that the signal never exceeds a user-specified level. The term *brickwall limiting* refers to a ratio of 20:1 to ∞ :1. By adopting these high ratios the incoming signal can never exceed the threshold value (Droney & Massey, 2001: 8).⁶⁵

Types of Compressors

Professional mastering engineers often use a number of different compressors and limiters as they apply DRC. These devices may be analog processors (e.g., Fairchild 670), digital models of these devices (e.g., UAD Fairchild emulator), or a combination of both. In addition, as with all signal processing devices, compressors and limiters can be either software or physical hardware units. Various applications of both analog and digital compressors are discussed in the following section.

Optical

As with all compressor designs, optical compressors split an incoming signal between the compressor's gain stage and its detection circuit, also known as the *sidechain* circuit. On optical compressors, this detection circuit sends electrical current to a lightsource proportional to the incoming signal's amplitude, and fluctuations in this lightsource are read

⁶⁵ I discuss brickwall limiting in more detail in the section below titled "Digital Compression." I also provide detail on how it contributed to the loudness war.

by a light sensor. At this point, gain reductions are applied according to the strength of the light directed at the sensor.

The optical compressor's reliance on a photocell-based element for controlling gain causes quite a slow response, or *attack*, time (Cousins & Hepworth-Sawyer 2013: 65). There is a slight delay in the time it takes for an optical unit to read an incoming signal, convert that signal to a series of discrete voltages to power a photocell, and then read the resultant light fluctuations via a sensor. Consequently, when optical compressors engage their gain reduction circuits, they always feature slow *attack* and *release* times in comparison to with other types of compressors. In fact, perhaps the most prized optical compressor, the Teletronix LA-2 A, features no variable attack/release parameter (Fig. 2.1.2-2.1.3).

Figure 2.1.2: Optical Compressor Signal Flow

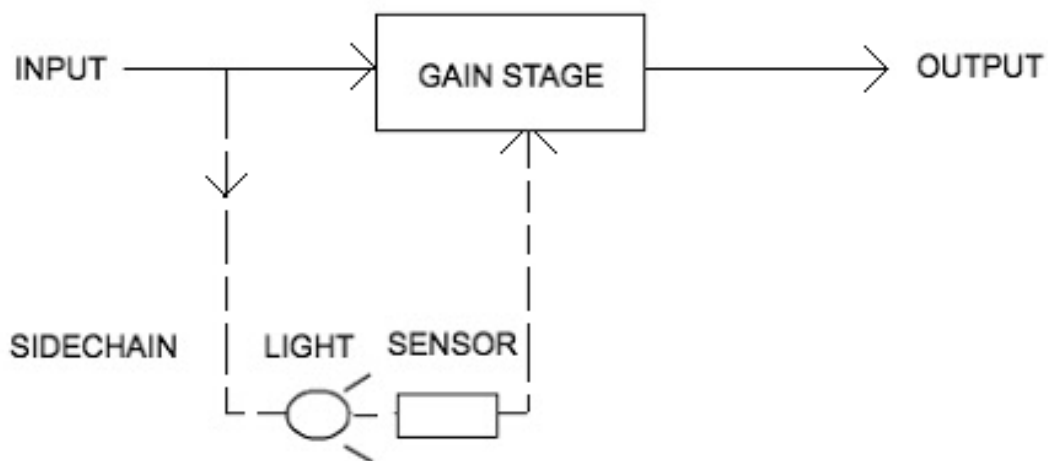

The graphic above illustrates signal flow in an optical compressor. An input signal is split between the sidechain detection circuit and the compressor's gain stage. The sidechain circuit controls the amount of gain reduction applied via a photocell and light sensor. A stronger signal sends more voltage to the photocell, and a weaker signal sends it less voltage.

Figure 2.1.3: Teletronix LA-2A



Figure 2.1.3 shows a popular optical compressor: the LA-2A. This unit features no variable attack/release parameter.⁶⁶

⁶⁶ Image reproduced from:
http://smhttp.39666.nexcesscdn.net/801433B/vking/media/catalog/product/cache/1/image/9df78eab33525d08d6e5fb8d27136e95/u/n/universalaudio_la2a_1_1.jpg

Variable-MU

Variable-MU compressors contain a vacuum tube within the sidechain detection circuit (Fig. 2.1.4, 2.1.5). This tube is electrically re-biased according to the amplitude of the incoming signal, and this continual re-biasing determines the amount of gain reduction the device applies (Haas 2008). Unlike other designs, the variable-MU compressor lacks a ratio control. Instead of designating threshold and ratio, engineers can only specify an input and output gain level. The compression ratio naturally increases as the detection circuit receives a greater signal amplitude. If a high input is fed into a low output setting, for example, this will often engage more extreme compression than a low input value and a high output value. While attack and release settings can be modified on some variable-MU devices, they often cannot be adjusted, and this makes these units unsuitable for musical applications which require fast acting compression (Cousins & Hepworth-Sawyer 2013: 67).

Figure 2.1.4: Vari-Mu Compressor: Signal Flow Diagram

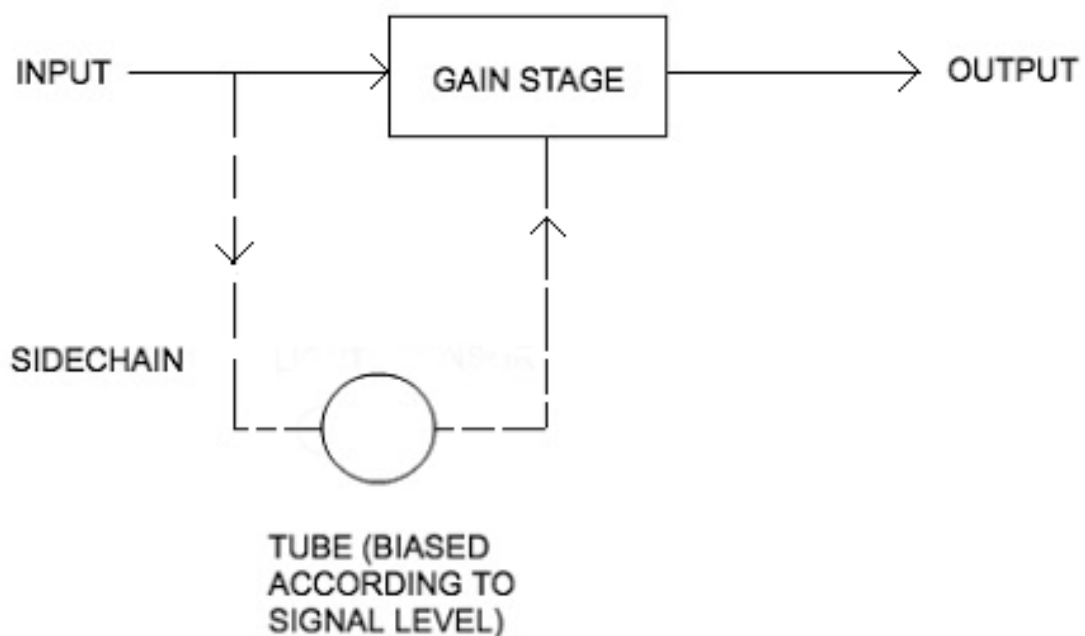

Figure 2.1.4 shows signal flow within a Variable-MU compressor circuit. The signal is split between a sidechain detection circuit and the device's gain stage. A tube in the sidechain circuit is constantly re-biased according to the incoming signal's level, and this tube controls the compressor's gain reduction.

Figure 2.1.5: Fairchild 670 Variable-MU Compressor



*Figure 2.1.5 illustrates the Fairchild 670 vari-MU style compressor. Notice the lack of dedicated attack and release controls.*⁶⁷

FET

FET compressors, such as Universal Audio's 1176, rely on a *field-effect-transistor* (FET) for gain reduction, instead of an optical cell or a vacuum tube (Figure 2.1.6-2.1.7). A FET uses an electric field to control the shape and conductivity of a charge-carrying channel. Universal Audio describes the technical operation of the FET as follows (2009: 31):

The FET acts like a variable resistor, where the resistance is determined by the control voltage that is applied to it. Note that the greater the voltage applied to the gate of the FET, the less resistance, hence large signals cause the FET to reduce the gain. Larger input signals result in a higher voltage from the gain control circuit, which will lower the gain, hence reducing the signal level. This is the basis of the limiting action. Note that the 1176LN is a feedback style compressor since the sidechain circuit samples the signal level after the gain reduction.”

FET compression naturally produces fast attack and release times, unlike variable-MU and optical compression. Hence, these units offer increased control over amplitude peaks, and a more heavily *coloured* style of compression (Cousins & Hepworth Sawyer 2013: 67). FET style compressors are used most frequently for tracking vocals or instruments, and rarely find use within mastering studios.

⁶⁷ This image is reproduced from <https://6e80timjxr-flywheel.netdna-ssl.com/wp-content/uploads/2012/11/Fairchild.jpg>

Figure 2.1.6: FET Compressor: Basic Signal Flow

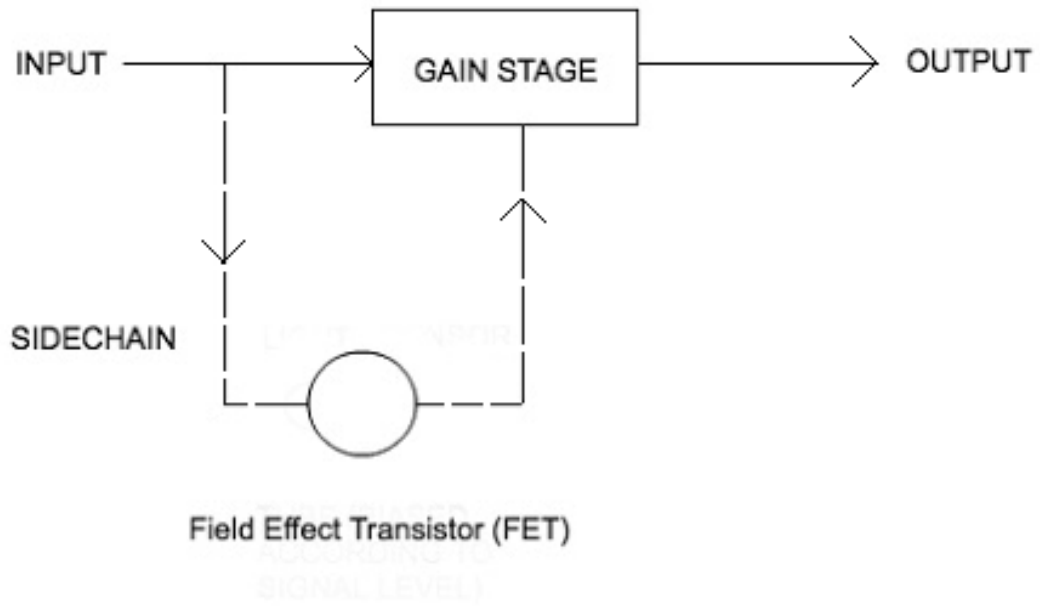

Figure 2.1.6 provides an overview of signal flow within a FET compressor. FET compressors rely on a field effect transistor, instead of a tube or photocell, to regulate DC voltage within the device's sidechain detection circuit.

Figure 2.1.7:FET Compression: The 1176



Figure 2.1.7 illustrates the 1176 compressor by Universal Audio. FET compressors are used most often during mixing and tracking.

VCA

VCA compressors attenuate signal amplitude based on the amount of current running through a *voltage-controlled amplifier* (VCA) located in the device's sidechain (Fig. 2.1.8-2.1.9).

These versatile compressors easily control attack and release parameters, and can provide, for instance, a smooth *gluing* effect during audio mastering and mixing.⁶⁸ Alternatively, a more aggressive use of VCA compression reduces the amplitude of a track's peaks (Cousins & Hepworth-Sawyer 2013: 68). This versatility makes the VCA style of compression most useful for mastering engineers who work with diverse music styles. Prominent examples of

⁶⁸ When sonic artifacts receive similar DRC processing, they sound as though they belong together. This is because a sound's amplitude characteristics contribute to what perceptual researchers call auditory stream formation (Moore 2013: 300; Shelvock 2016: 78). Engineers refer to this effect as *glue* (Cousins & Hepworth-Sawyer 2013: 74).

compressors that employ a VCA circuit topology include the SSL G-Series, Vertigo Sound VSC-2, and the API-2500.

Figure 2.1.8: VCA Compressor Signal Flow

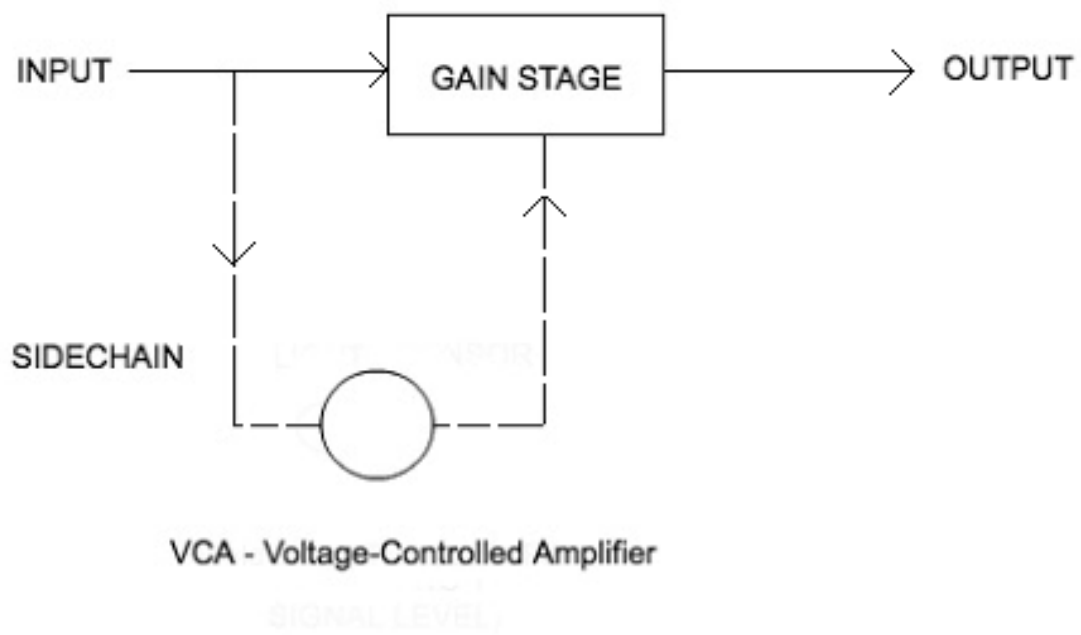

Figure 2.1.8 shows signal flow in a VCA compressor. The device's sidechain detection circuit relies on a voltage-controlled amplifier to vary the DC voltage according to the input level.

Figure 2.1.9: VCA Compression, The API 2500



The API 2500, illustrated above, is a popular VCA compressor. VCA compressors are prized for their versatility, and they make an excellent addition to mastering, mixing, and tracking rigs.

Digital Compression

The digital recording era ushered in a number of software tools that replicate the beloved analog hardware units discussed above. This digital software (usually called *plug-ins*) can loosely replicate the dynamic and spectral profile of classic optical, variable-MU, FET, and VCA compressors. These plug-ins, of course, cannot fully model the sonic results of their hardware counterparts, but they are routinely used to achieve DRC.

When software compressors emulate their hardware counterparts, software designers typically copy the design of hardware interfaces. These virtual interfaces usually replicate, or heavily reference, the control surface of hardware units (Marrington 2016: 52). UAD, for instance, markets a popular software emulation of the original Fairchild 670, but digital compressors often do not model specific hardware units. Ableton's native compression

software, for example, does not model FET, VCA, Optical, or vari-mu style compression, whereas Logic's native compression plugin can copy each of these styles.

In addition to providing affordable emulations of classic equipment, software designers have developed what is known as *multiband compression* – a technique that is not possible in the analog domain. The hardware circuits discussed above (and their software counterparts) are all methods for *broadband* compression. Broadband compression applies compression across all audible frequency bands simultaneously, and this method generally delivers consistent results when applied to signals with balanced frequency content (Cousins & Hepworth-Sawyer 2013: 79). However, another treatment option for signals with an atypical (or problematic) frequency distribution is multiband compression. This technique applies DRC within discrete spectral regions, with users defining a series of *crossover* points, which could designate, for instance, three (or more) large frequency regions. The first band is often set to control 20 Hz to 300 Hz, the second region 300 Hz to 4 kHz, and the third 4 kHz to 20 kHz (Cousins & Hepworth-Sawyer 2013: 81). However, engineers alter these crossover regions as required. From this point, DRC can be applied within each selected frequency zone, instead of all frequencies simultaneously.

Beyond multiband compression, the *brickwall limiter* is another highly impactful digital tool. Brickwall limiting is a subcategory of DRC that involves compression at a ratio above 20:1 (to ∞ :1). This technique also uses digital technology to *look ahead* for any incoming signal peaks — an impractical task with analog technology, which can only respond to changes in level as they occur. Brickwall limiting was first made commercially available in the early 1990s, and this digital processing technique became one of the primary weapons in the ongoing *Loudness Wars*.⁶⁹ Through the application of brickwall limiting, Oasis' breakthrough album (*What's the Story*) *Morning Glory?* (1995) registered at an

⁶⁹ The Loudness Wars are discussed extensively in Chapter 1.

average level of -8 dBFS, when most other records at the time averaged -12 to -17 dBFS.

Although Oasis is a pop group, this album featured stronger RMS values than Guns ‘n Roses hard rock classic *Appetite for Destruction* (1987), which set the previous upper limit for loudness at -15 dBFS (Southall 2006).

The invention of brickwall limiting — and its widespread adoption by mastering engineers — completely changed industry expectations for how loud records could be. In fact, *(What’s the Story) Morning Glory?* (1995) marked the beginning of a new era of digital loudness. Adam Ayan (in Hepworth-Sawyer & Hodgson: forthcoming) of Gateway Mastering Studios, a leading American mastering house, describes how recordings continued to increase in overall loudness levels after Oasis, and into the 2000s:

The expectation of how loud something should be in 2015 is so dramatically different than in the late 90s when I first started out. I don’t even mind going on record to say that there are expectations of loudness today that would have had you fired from a job 15 or 20 years ago. I don’t really complain about loudness that much because it is simply a reality, and it’s not going to change that dramatically in the future. Every time we think it’s going the other way it doesn’t. In fact, it usually goes farther into the realm of loudness. That’s been my experience. My philosophy is that I know my clients are looking for a certain amount of loudness, and I know that’s very important to them. I also know that if I don’t do it, I won’t get the gig and they won’t work with me — that’s just a fact. So I know they want that, but the challenge that’s posed to me is now: how do I establish that loudness and how I make it also sound musical? As a mastering engineer, that’s not the easiest thing to do because it takes a lot of finesse and hard work. I mean, it’d be one thing if you could just say, “well I can just push it through more compressors or distort the thing more or whatever,” and use these heavy-handed methods that achieve loudness in a very non-musical way. But, that’s not what I’m in business for, and that’s not what I want to do with recorded music. So I take it as a really serious challenge to attain the kind of loudness that’s expected today in 2015, but to do it in the most musical way possible.

As Ayan explains, expectations for a record’s loudness profile have changed dramatically since the early 1990s. Now, owing to the digitization of the record industry, records are much louder than ever, and brickwall limiting has become an integral audio mastering technique.

Of course, as Ayan suggests, the work of the mastering engineer is more difficult than simply

turning on a limiter in order to make a record louder (Cousins & Hepworth-Sawyer, 2013: 58).

Compression Methods and Approaches

Now that I have explained the general operating principles of mastering DRC tools (e.g., threshold, ratio, attack, release, knee, peak/RMS detection), as well as various compressor types (e.g., optical, variable-mu, FET, VCA, digital), I will now describe how engineers use these devices, for few sources explain the application of compression during audio mastering.⁷⁰ Perhaps this is because DRC requires experience and training in order to identify the sound of compression aurally. To this end, experienced engineers train their ears to hear compression at work.⁷¹ The methods discussed below were acquired through sources such as these, as well as available trade publications and interviews, training/job shadowing at Jedi Mastering, my previous research (2012), and through the development of my own mastering portfolio.

Light Compression

Ratio: 1.5:1 (or less)

Threshold: Low

Attack: 30 ms (medium - slow)

Release: 300 ms (medium) or Auto⁷²

⁷⁰ As it stands, Hodgson (2010: 222-223), Cousins & Hepworth-Sawyer (2013), and Hepworth-Sawyer & Hodgson (Focal Press: forthcoming) offer the only published accounts that address specific ways of applying DRC during audio mastering. Surprisingly, this area is omitted in Katz well-known text (2007).

⁷¹ In fact, award-winning engineers such as Matthew Weiss and Kevin Ward offer courses on learning to *hear* compression on their respective websites.

⁷² Reproduced from Cousins & Hepworth Sawyer (2013: 69).

These settings provide a starting point that allows users to hear the compressor working on the signal being processed. By employing a low threshold and ratio, the gain reduction circuit remains active, yet the device will only apply a few dBs of compression when engaged. However, depending on the source material, these settings may require some adjustment. If, for example, the material is particularly loud, the threshold value must be increased to avoid the application of too much compression.

These *light compression* settings use moderate attack and release times. Slower attack times cause a compressor to respond *after* the transient triggers the device's gain reduction circuit. The remaining portion of the signal (e.g., sound occurring after the transients) is compressed. Engineers call this part of the signal the *body* segment (Cousins & Hepworth-Sawyer 2013: 69). Compression can be used in two different ways at this point. Engineers may choose to either attenuate the body of a track or raise the track's average amplitude by applying make-up gain (Hodgson 2010: 218).⁷³

In addition to providing subtle dynamic control, some engineers use light compression to alter a track's timbral design. Nick Cook of Extreme Music (Sony ATV) explains this approach as follows (in Hepworth-Sawyer & Hodgson: forthcoming):

Rather than engaging heavy compression, my compressors are mostly in the chain to imbue the signal with the sound of all the tubes and components, because these components engage with the track's frequency content. It's just a case of getting those to sound as best as possible, and then I might have another compressor after that — simply acting as a gain stage — but I feel strange calling these devices “compressors” because, in mastering, people don't really use compressors for compression.

The two main tube compressors I use here are the Fairchild, and then I've got a Manley Vari Mu. Both devices feature a very distinctive sound, and I've become accustomed to how these units shape tone. That doesn't mean I simply turn it on and it's going to sound exactly how I think it's going to sound. Instead, I might have to

⁷³ Please see this chapter's section entitled “Compressor Controls” for an in-depth description of how make-up gain raises a signal's average level.

take it out, or do some EQ beforehand just to make the tone of it work well. In mastering, I kind of always see compressors like a form of EQ, but it's also to do with gain-staging as well. You send the signal through tubes, transformers and circuitry, and it will just change the sound even if it appears like it's doing nothing, it's always doing something. It always is, and that's kinda how I see it.

As Cook explains, light compression can be used to simultaneously provide DRC while also shaping a signal's timbre. Indeed, various tubes, transformers, and other components can shape a sound's spectral properties, and Cook infers that mastering engineers often use compressors to achieve this type of sonic colouration.

Audio Example

Audio example 2.1.1 demonstrates the sound of light compression applied to a track. The track is presented unprocessed for 15 seconds, and then light compression is applied. In order to hear the foregrounding of this track's *body* characteristics, listeners should focus their attention on the snare drum and synthesizer pads.

Medium Compression

Ratio: 2:1

Threshold: Low to Medium

Knee: Soft

Attack: 10-50 ms (medium)

Release: 300 ms (medium) or Auto⁷⁴

⁷⁴ Reproduced from Cousins & Hepworth Sawyer (2013: 70).

This method simply repeats the “light compression” strategy with a higher ratio and lower threshold, but a *soft knee* setting should also be used to cause the onset of compression to sound less noticeable.⁷⁵ Alternatively, engineers may choose a compressor with a variable-knee setting, such as the variable-MU design (Cousins & Hepworth-Sawyer 2013: 70). Medium compression works best on records that exhibit a typical dynamic balance between different structural sections, such as verses and choruses. In pop music, for instance, this refers to the genre’s expected macrodynamic scheme, where *chorus* segments are normally louder than *verse* segments.

The ratio and threshold values shown in the above example may require adjustment. In order to help budding engineers determine ratio/threshold values, Mark Cousins and Russ Hepworth-Sawyer discuss the desired aesthetic outcome of this approach (2013: 71):

The key point [. . .] is that you start to create some distinction between a lighter ratio in the verse, and a pushier ratio in the chorus. Rather than a one-size-fits-all ‘broad brush’ mastering compression, you’re starting to create a little more distinction between the different passages in the music.

As these engineers explain, DRC applied during mastering should aid the listener’s perception of traditional compositional elements within a song’s structural form. Poor approaches to DRC, on the other hand, obfuscate demarcations between verses and choruses by subverting the listener’s loudness expectations. When setting ratio and threshold values, then, engineers try to be sensitive to such dynamic expectation.

Audio Example

Audio example 2.1.2 demonstrates the sound of medium compression. At first, the track

⁷⁵ Please see the section entitled “Compressor Controls” for more information on *knee*.

plays without the application of additional compression. At 00:15, medium compression is applied.

Heavy Compression

Ratio: 4:1

Threshold: Medium to High

Attack: 10 ms (fast)

Release: 100-300 ms (fine-tune to track's tempo)⁷⁶

Compression begins to sound more noticeable at ratios above 2.5:1. As Mark Cousins and Russ Hepworth-Sawyer remark on the use of a stronger compression strategy, “we’re actively using the ‘sound’ of compression in our master, rather than just gently controlling the dynamic range” (Cousins & Hepworth Sawyer 2013: 71). In other words, this compression strategy is intended to imbue the source material with further sonic *colouration*. Thus, heavy compression substantively alters the dynamic characteristics and frequency distribution of a signal.

However, one caveat for affecting heavy compression is the tendency for this technique to cause music to sound as though it were *pumping*. In other words, the compressor’s transition to an *on*-state from an *off*-state can create fast undesirable changes in amplitude. To combat this pumping effect, attack and release settings can be altered. On the decisive use of these settings, Mark Cousins and Russ Hepworth-Sawyer remark (2013: 72),

⁷⁶ Reproduced from Cousins & Hepworth Sawyer (2013: 71).

The finesse of heavier compression comes with the attack and release settings, especially as this forms the principle sound of the compressor going about its business. Start from a suitable ‘vanilla’ setting — with attack around 10 ms, and release around 100 ms. Lengthening the attack time will let more of the transient energy through from the track, which can help add percussive bite, but might also impinge on the compressor’s ability to control peak signals.

The release time is important to get the compressor breathing in the correct way. Ideally, the release shouldn’t be too fast, but graduated to match the feel and tempo of the track. As a rough guide, if the compressor can’t restore most of its gain between beats then the setting is probably too slow.

Perhaps the most musically impactful consequence of heavy compression is the necessity for recordists to coordinate DRC with a track’s rhythmic pulse (Cousins & Hepworth-Sawyer 2013: 72). Thus, the application of heavy compression during audio mastering requires an understanding of a song’s general rhythmic structure. If, for example, the rhythmic pulse of the music is not taken into consideration, the resulting audio may *pump* in a detrimental way.

Audio Example

Audio example 2.1.3 illustrates the application of heavy compression during audio mastering. The beginning of this example features no additional compression, but after 15 seconds, the track fades out, and I apply heavy compression. Listeners will notice a stark increase in perceived loudness once compression is engaged.

Audio Example

Audio example 2.1.4 demonstrates the sound of a compressor *pumping* from hypercompression, as discussed in the above passage.

Peak Limiting/Attenuation

Ratio: 8:1 to infinity:1

Threshold: High

Attack: Fast

Release: Fast⁷⁷

For music that features widely varying transient levels, engineers may choose to apply a form of peak control to tame amplitude spikes. In this case, the DRC settings prescribed above are known as peak *limiting* or *attenuation*. A high threshold and ratio value ensures that amplitude spikes are attenuated without drastically altering the underlying dynamic levels of the source. As a result, when applying DRC to attenuate peaks, the compressor spends very little time in an active state when compared to the *Light Compression* approach described above.

Audio Example

Audio example 2.1.5 provides an illustration of peak limiting. To demonstrate this technique, I have created an exaggerated example. At first, the example plays without the application of additional peak limiting. At 00:15, I apply strong peak limiting to the point of distortion. The next segment (00:30-00:45) plays the track without peak limiting once again, and then I apply a more reasonable amount of limiting (00:45-1:00). Listeners should pay attention to changes

⁷⁷ Reproduced from Cousins & Hepworth Sawyer (2013: 73).

in overall loudness as the limiter engages and disengages.

Parallel Compression

“Classic”

Ratio: 2:1

Threshold: Low

Attack: Medium

Release: Medium

Mix: 50 per cent

“New York”

Ratio: 4:1 to infinity:1

Threshold: Medium to High

Attack: 10 ms (fast)

Release: Adjust to track’s tempo — around 200 - 300 ms

Mix: 50 per cent⁷⁸

Parallel compression may be the most versatile DRC approach mastering engineers use. In fact, they employ this technique on both pop and classical records (Cousins & Hepworth-Sawyer, 2013:74-76). To perform parallel DRC, engineers blend a compressed signal with the original unaltered signal through the *wet/dry* setting (although other methods may be used). A plugin called *The Glue* by Cytomic, for example, includes a *wet/dry* control that increases the level of the compressed signal until 100% is reached. Alternatively, a

⁷⁸ Reproduced from Cousins & Hepworth-Sawyer (2013: 74-76)

setting of 0% allows none of the compressed signal to pass through. The primary reason engineers use this technique is for the creation of a more *transparent* form of DRC by mixing the original and compressed signals together.⁷⁹

Depending on the source material, genre, and needs of the client, engineers adopt two main approaches for applying parallel DRC. The first approach, listed above as the *Classic* template for parallel DRC, blends a lightly compressed signal with the original unaltered version. When this technique works well, it should produce a gentle boost to a track's body, while also preserving transient detail (Cousins & Hepworth-Sawyer 2013:74-76). This technique provides an effective strategy for subtly taming music with a dynamic range that may exceed the reproduction capabilities of playback devices, such as in Western Art Music.⁸⁰

While some classical recordings may use the *Classic* settings described above, many popular recordings instead employ the *New York* approach to parallel compression. Mark

⁷⁹ *Transparent* refers to a more subtle approach in signal processing. By blending processed and unprocessed signals together, engineers can alter a signal without changing it drastically.

⁸⁰ Although classical recordings feature a much wider dynamic range than pop recordings, no recording can reproduce the dynamic range of *live* sound. For this reason, engineers often use some form of light DRC on classical recordings. As engineer Mike Senior states, “Don't stray over a ratio of around 1.1:1 for classical recordings, though, if you want to play things safe, and if you're getting gain-reduction of more than about 4-5dB, you've probably got the threshold set too low. I'd personally set the attack time fairly fast to track the signal levels pretty closely, and then go for faster release times for more detail/ambience and longer release times for less detail/ambience, but this will inevitably be a matter of taste. Any isolated accented chords will be particularly revealing of potentially unpleasant compression artifacts, so listen out for how those sound. [...] A more transparent approach to compression is to use a compressor as a send effect, mixing the compressed signal in with the unprocessed one — this is often referred to as parallel compression. For this to work, you need to make sure that the compression processing doesn't also introduce any delay, otherwise you'll get a nasty kind of static phasing sound. That said, most software DAWs now have comprehensive plug-in delay compensation, so this is becoming less of a problem for people these days. When working like this, you can usually get away with slightly heavier compression, but I'd stay below a ratio of 1.3:1 to be on the safe side. What some engineers do is automate the compressed channel's fader, rather than the main channel's, adding in more of the compressed signal during quieter sections. This can work really well, as it's often when the music is quietest that it benefits most from added detail” (Senior 2008).

Cousins & Russ Hepworth-Sawyer offer the following advice for setting up *New York* parallel compression during audio mastering (in Cousins & Hepworth-Sawyer 2013: 76):

Start by configuring your compressed channel. Here, it's important that we're not too subtle, and that we're really attacking the transients in the mix. A good setting, therefore, would be a 4:1 ratio with a fast attack and graduated/medium release. You should aim for some deliberate transient reduction, a good dose of additional level, and a release time that restores itself across the beat. Don't be afraid if you're pushing 6 dB of gain reduction, as long as the compressor is doing some work!

When performing parallel DRC in this way, users should apply *heavy compression* within the *wet* signal, which is then blended together with the original signal. Although the above example suggests a 50% wet/dry setting, a lesser or greater amount of the compressed signal may be employed depending on the source material, and the desired output.

As with all techniques discussed in this chapter, engineers use personal taste when applying parallel compression. In the same way that a chef carefully selects specific spices to enhance a dish, mastering engineers also select techniques that complement the music being finalized. Mastering engineer Barry Grint (Madonna, Prince, Puff Daddy, Eric Clapton) offers the following description of how parallel compression can enhance a project (in Hepworth-Sawyer & Hodgson: forthcoming):

[Parallel compression] was something I had started to experiment with after having found it being used in tracks that were coming from America. The idea is that, you're adding more power to a track, but you don't end up with something that has no peaks. It's kind of like adding a powerful core within the original track. There are certain artifacts produced by this method, and you have to be really careful about unusual pumping effects, for example — not the typical ones you would expect with compression. Sometimes you have to ride the gain [i.e., manually adjust in real-time] of the parallel compression in order to get something that is working seamlessly. When you get it right, it can add a body to something where compression or limiting would have just sounded [weak].

It's like most compression — it's all down to the attack/release time. For example, if you do it in the box, you copy the audio down onto another stream. You put that into a compressor or a limiter, hit that limiter really hard, and then you're mixing that result back into the main unadulterated track. Since that compressor is being hit so hard, sometimes you'll hear the release setting having more of an effect than you would have normally expected. This is where you have to ride the output of the compressor

so that you're also manually riding the peaks and troughs. This way, when the compressor does suddenly release — which in turn makes it pump — you've pulled down that output level so that the compression isn't as noticeable. It gets lost in the main body of the track again.

As Grint cautions, one must ensure the compressor does not introduce pumping artifacts as it *releases* the signal. To combat this, engineers may opt to operate the compressor's *release* setting manually over a track's duration. In other words, engineers can adjust a compressor's *release* setting to change over the course of a song. To accomplish this, they simply record (or digitally track) these adjustments to the release parameter.

Audio Example

Audio example 2.1.6 demonstrates *New York*-style parallel compression. In this example, I use a compressor with a wet/dry setting, and a compression ratio of 4:1. The beginning of this track features no parallel compression (00:00-00:15). Then, I apply NY parallel compression with a wet/dry setting of 25% (00:15-00:30). At 30s (00:30), I apply stronger NY parallel compression, with a setting of 50%.

Audio Example

Audio example 2.1.7 demonstrates a more transparent approach to parallel compression in a segment of a track that transitions between verse and chorus. At first, this segment uses no additional parallel compression, but at 15 seconds, I repeat the example with parallel compression applied.

Multiple Stages of DRC

First Stage:

Ratio: 2:1

Threshold: Low

Attack: Medium

Release: Medium

Second Stage:

Ratio: 8:1

Threshold: High

Attack: Fast

*Release: Auto*⁸¹

Mastering engineers often use multiple stages of compression. For instance, two or more of the approaches covered in this chapter can be combined to address multiple dynamic issues within a signal. In the above example, the first stage of compression provides some light dynamic control over *body* of the music,⁸² while the second stage provides control over amplitude peaks. Mastering engineer J.P. Braddock offers the following insight regarding multi-stage DRC (in Hepworth-Sawyer & Hodgson, forthcoming):

Limiting, in my opinion, is something that happens after we master it. I don't think about limiting as part of the actual mastering process. It's something there that can facilitate more perceived volume, if required, relative to the production. The actual volume, as in how loud we make something, comes from dynamic and internal balance. If you've got those two things correct you can apply the right type of limiter.

⁸¹ Reproduced from Cousins & Hepworth Sawyer (2013:76-77)

⁸² As stated earlier within this chapter, I borrow the term *body* to refer to elements of a waveform that occur after the initial transient segment (Cousins & Hepworth-Sawyer 2013: 69).

As Braddock explains in the above quotation, some engineers effectively consider peak-limiting to be a *post-mastering* process. In other words, parameters such as stereo distribution, noise floor, distortion levels, frequency distribution, and internal dynamic balance should be addressed before limiting occurs.

Audio Example

Audio example 2.1.8 illustrates the common approach of applying multiple stages of DRC. At first, the track plays without the use of additional DRC. The second segment of this example (00:15-00:30) adds light compression, and the third part (00:30-00:45) features both light compression and peak limiting.

Using the Multiband Compressor

The approaches to compression discussed to this point apply DRC throughout the entire audible frequency spectrum (approximately 20Hz to 20kHz). Multiband compressors, on the other hand, allow engineers to apply DRC over user-selected frequency regions. In a practical sense, engineers use multiband compression to process problematic spectral regions. If a track exhibits an overabundance of low frequency energy, but an otherwise *genre-friendly* dynamic and timbral scheme, a mastering engineer could attenuate this concentration of problematic low frequencies while also preserving mid and high frequency information.

Similarly, if a record demonstrates an unnecessarily harsh upper frequency sound, engineers may consider lightly compressing the 5 to 7kHz range to provide a more balanced timbre.⁸³

To use a multiband compressor, one first defines a series of *crossover* points (Fig. 2.2). These points designate the boundaries of the frequency ranges where DRC will be applied. One might specify two crossover points, at 300 HZ and 4 kHz, and this would provide an engineer with DRC over three frequency regions: 0 Hz-300 Hz, 300 Hz-4 kHz, and 4 kHz-20 kHz (Cousins & Hepworth-Sawyer 2013: 81). Once three areas have been set, users can adjust them for the purpose of focusing on a problematic spectral region. For instance, if an excessively loud sub-bass has a fundamental frequency located between 20Hz and 40Hz, an engineer may consider compressing the region between 20Hz and 150Hz in order to clamp down on this instrument's fundamental frequency and first (and sometimes second) order harmonics.

Once crossover points are defined, users can audition the compressor's effect on each frequency range by applying gentle DRC across all bands. Because excessive bass energy is particularly problematic for both compressors and stereo representation, many engineers begin by addressing this range. If a mix exhibits weak low-frequency content, then multiband compression could address this deficiency if additional make-up gain is applied (Cousins & Hepworth-Sawyer 2013: 82). Should this region need to be attenuated, engineers simply compress it without applying additional gain. In this way, multiband compression is a useful tool for attenuating a specified frequency range within a signal; or alternatively, one can boost a given frequency band by first applying compression, and then adding make-up gain to boost the average level of the targeted spectral zone.

⁸³ If, for instance, harshness in this region results from distortion or compression, multiband expansion can effectively *undo* these artifacts by reducing the audibility of the distortion in this region (Katz, 2007: 142).

Figure 2.2: Multiband Compressor Crossovers



Figure 2.2 demonstrates how engineers set up crossover frequencies with a multiband compressor. These regions may be modified to include a smaller or larger bandwidth. Of course, engineers may opt to use fewer than 3 crossover points.⁸⁴

Once bass frequencies have been treated, engineers often concentrate on high frequency content, as this spectral region contains a significant portion of signal's transient detail. Frequencies commonly associated with what is known as *sonic excitement* are also found in this area. However, over-compressing this region can cause a signal to sound distorted or harsh. This is because the human ear is quite sensitive to amplitude modulation in high frequencies (Moore 2013: 84-85; Cousins & Hepworth-Sawyer 2013: 83). Consequently, users should avoid excessive gain reduction in this region, and adopt a medium-to-slow attack time where possible (Cousins & Hepworth-Sawyer 2013: 83). This will cause the compressor to engage after the transient, and by doing so, the resulting amplitude modulation will sound more subtle.

⁸⁴ Image reproduced from http://help.izotope.com/docs/ozone/pages/images/5_multiband_1.png

After unwieldy high and low frequencies have been treated, mastering engineers usually consider midrange frequency content. Generally speaking, middle frequencies are musically important because the fundamental frequencies of most melodies are expressed in this range (Cousins & Hepworth-Sawyer 2013: 105). Moreover, common elements such as snare drums, pianos, and electric guitars often feature rich mid-frequency content. When engineers assess this spectral region, they often use a trial and error approach for correcting problems. If a mastering engineer receives a rock mix in which distorted rhythm guitars sound *weak*, she or he could apply compression (and makeup gain) to the low-midrange (250 Hz- 500 Hz). If boosting this region happens to alter the mix in an undesirable way — perhaps causing the snare drum to sound *muddy*, for instance — engineers can experiment with different crossover frequencies in order to achieve a more desirable balance.

The ability to compress user-specified frequency zones provides engineers with unprecedented spectral and dynamic control. In fact, David Wrench (FKA Twigs, Caribou, Jungle) favours this technique, discussing his own application of multiband compression in the following interview excerpt (in Hepworth-Sawyer & Hodgson, forthcoming):

I'm a big fan of multiband compression, I think it's a really really useful tool. I use it on bass instruments because often when you're compressing, what you want to actually be controlling are certain [problematic] frequencies. So by just selecting a certain band, you can allow the top end of the bass come through as it wishes, while simultaneously attenuating the low-mids, for example. With vocals, sometimes you think you can be compressing, but all you want to be doing is controlling the harshness that comes through on certain loud sections. So, in those cases it makes sense to be using the multiband compression at the top end, maybe around sort of high-mids, just to control it when it gets peaky [...] if you just hear something that's peaking, instead of EQing that frequency out for the whole track, just control it when it builds up too much. I nearly always use multiband across the mix, in fact something I often do across the mix is I'll have an EQ, and a compressor, then a multiband and limiter, and actually, that's how I master my mixes for previewing.

In this quotation, Wrench describes a method of controlling the dynamic range of a signal within a user-defined frequency spectrum. He also states that he uses multiband compression

when creating quasi-masters by placing this device on the stereo bus. Although Wrench uses this technique for client preview, mix-level stereo bus compression is occasionally used on pre-masters.⁸⁵

Audio Example

Audio example 2.1.9 demonstrates the application of multiband compression to a mix. In this case, I have used the multiband compressor to enhance low frequency content. At first, the track plays without the multiband compressor. After the fadeout (00:15), the multiband compressor is applied in order to enhance the track's low-end.

Other Methods for Adjusting Dynamic Range

A number of additional methods for altering the dynamic profile of a recording exist, and in this section I concentrate on the most common. These methods resist simple categorization as either compression or limiting, and thus require separate analyses. Consequently, I evaluate audio mastering techniques for dynamic reconfiguration throughout the stereo field, dynamic expansion, and sidechain filtering.

⁸⁵ Many mix engineers provide clients with *quasi-mastered* material. As mixes should always be less loud than masters, this practice aids the client by creating a preview of what their record may sound like after additional limiting/DRC is applied to the stereo bus.

DRC and Stereo Imaging: Mid/Side Processing and Dynamic Reconfiguration

Mid/side (M/S) processing applications allow engineers to alter sounds emanating from the *middle* and *side* portions of a stereo image separately, and M/S compression refers to the technique of applying DRC discretely to middle and side channels in a stereo mix. This technique is useful in situations where a central musical element, such as vocals or a snare drum, mask sounds emanating from the sides of a mix, which might contain layered electric guitars (Watson 2012). Thus, mastering engineers rebalance a track's stereo configuration using this technique.

In addition, mid/side compression remains important for mastering vinyl discs, as Mark Cousins and Russ Hepworth-Sawyer explain (Cousins & Hepworth-Sawyer 2013: 85):

As a point of reference, M/S [mid/side] compression was and still is an important part of mastering for vinyl, which is why compressors such as the Fairchild 670 have an M/S mode labelled as lateral/vertical compression. Vinyl is effectively cut in M/S with lateral movements of the needle forming the summed mid signal, with the vertical movements carrying the side. By compressing the lateral and vertical signals, a cutting engineer could control the movements of the needle, optimizing the cut and ensuring that the final record would playback effectively.

These engineers highlight the importance of mid/side compression as an essential technique for crafting playable vinyl discs, and vinyl certainly remains an important playback medium. For example, despite the prevalence of streaming and other digital music media, 9.2 million vinyl discs were sold in the US in 2014, and industry experts forecast an upward trend in sales in the future (Palermino 2015).

Mastering engineers tread carefully, however, when applying M/S processing to both analog and digital records, as the technique can drastically reconfigure dynamic information across the stereo spectrum. When restoring old records, or correcting a faulty mix, such invasive sonic alteration may be desirable, but M/S processing risks undoing or destroying the work of other engineers on the project (such as mixing personnel). Mix engineer Alastair Sims remarks on this phenomenon (in Hepworth-Sawyer & Hodgson, forthcoming):

If it's rock then you generally have guitars panned hard left or hard right. If it's Pop then you have a lot of vocals that are panned hard left and right or dead up the centre. I spend hours trying to get that balance right. If you just go and crank up the sides then you're turning the guitars up or down and completely changing the balance. That's not what I want.

For Sims, the overapplication of M/S processing might ruin a carefully balanced array of guitars or vocals. Mastering engineer Adam Ayan not only corroborates Sim's view but also makes it clear that he prefers to avoid operating in M/S mode (in Hepworth-Sawyer & Hodgson, forthcoming):

One reason I don't use MS is that the mixes I work on don't need it. For instance, I find that on a regular basis I get really good mixes, and I feel like MS is a tool that you can use creatively to fix a problematic mix. So, because I'm fortunate enough to get really good mixes, perhaps that's why I'm hearing more of the negative byproducts and less of the benefits of using it. Thus, mid-side processing has never really been a tool that I've used. I mention that because when I talk to engineers who do like to use it, I feel like they're only doing that because they're trying to save a bad mix.

While the reservations of Sims and Ayan are certainly valid, many mastering engineers service a more self-sufficient (or unsigned/D.I.Y.-based) clientele.⁸⁶ These people often require mastering engineers to provide a more invasive level of sonic correction or enhancement, mainly because the trend of widespread project/home studio recording has significantly increased the number of poorly configured mixes. As a result of the overwhelming prevalence of amateur mixes today, corrective tools such as M/S are used more frequently. Mastering engineer Bryan Martin has remarked on the current need for M/S compression by offering (in Hepworth-Sawyer & Hodgson, forthcoming):

⁸⁶ Professional mastering engineer J.P. Braddock believes that the music industry — and audio mastering — have become a cottage industry. He states (in Hepworth-Sawyer & Hodgson, forthcoming):

There's more of a cottage industry aspect to the music industry currently when compared to the past. The same thing is happening within audio mastering as we speak. For example, there are many mastering engineers who work from a place that wouldn't be classified as a commercial enterprise space. The Town House doesn't exist in the way that it once did, for instance.

This width fetish started because people don't mix well anymore. [For example, a client cannot] make it wide, so [they] use this width plug-in and decorrelate the center image — which kills the groove and messes up the bass content. It also introduces a lot of really bad phase information. Then, of course, they want to cut to vinyl. When considering the style of mixes today, with all the excess high and low frequency crap, it becomes impossible to cut to vinyl. That's another thing that is really bad in the digital world: you can put anything on a CD, but now everything is cut in vinyl and they give you these mixes that in the vinyl age would have been rejected because we have all of this out-of-phase and high frequency crap. So I think the width thing is just another artifact of complete ineptitude in mixing. I never do it, unless the mix is so decorrelated that I will actually make it narrower so that the groove works.

Although Martin states that he prefers to avoid M/S encoding, he will resort to it to reduce the stereo width of a recording when necessary. And, indeed, since the general level of professionalism in mixing seems to have declined, because of the rise of amateurism, more drastic tools are occasionally required to master audio.

Audio Example

Audio example 2.2.1 demonstrates Mid/Side compression. At first, no M/S DRC has been applied, but the second segment of this example (00:15-30) reduces stereo width by compressing the side channels. The third segment (00:30-00:45) enhances stereo width by gently compressing the mid channel.

Dynamic Expansion

Dynamic expansion is typically used for two purposes: to clean up a *noisy* track (see Chapter 1) or to subtly increase the dynamic range of a mix. There are two varieties of expansion,

downward and *upward* (Cousins & Hepworth-Sawyer 2013: 86). *Downward expansion* can temper low-level noise by reducing the overall gain when the signal drops below a user-defined amplitude threshold. As with compression, a *ratio* value determines the amount of expansion the device applies. A ratio of $\infty:1$, for example, will cause the expander to mute the signal when gain falls below the threshold. However, such a large ratio is not always necessary, as even 6 dB of gain reduction can significantly reduce low-level noise in a recording (Cousins & Hepworth-Sawyer 2013: 89).

When using *upward expansion*, the expander will raise the overall gain when a signal drops below the user-defined threshold. While a less common form of dynamic processing, upwards expansion increases the dynamic range of a signal, especially when signals appear to be overcompressed, and are in need of a wider dynamic range.⁸⁷

Audio Example

In audio example 2.2.2, I demonstrate downward expansion — the most commonly used form of expansion (Katz 2007: 115). Downward expansion attenuates low level passages, so that these moments are quieter than before. In this demonstration, the audio plays without the application of downward expansion for 15 seconds. After this point, downward expansion is applied to increase the dynamic range of the track.

Audio Example

In audio example 2.2.3, I demonstrate upward expansion. The track plays for 15 seconds

⁸⁷ Human hearing is quite sensitive to amplitude modulation in high frequencies (Cousins & Hepworth-Sawyer, 2013: 83). If a segment of music is over-compressed, it is likely that high frequencies will sound distorted due to excessive amplitude modulation. To combat this, upwards expansion may be a helpful tool for restoring a record's high frequency information.

before upwards expansion is applied.

Sidechain Filtering

As discussed earlier in this chapter, compressors rely on a *sidechain* to detect fluctuations in signal amplitude. However, an unfortunate drawback of these detection circuits is that some frequencies are more likely to artificially trigger gain reduction than others. An excessive amount of low-end frequency information — a common issue mastering engineers face — may inadvertently trigger the compressor's gain reduction circuit, because the sidechain could read this information as excessive amplitude in the signal. Since low-end spectral information contains more energy, these frequencies occupy a larger portion of the available headroom (i.e., up to 0 dbFS) than other frequencies. To reduce such excessive low frequency content, mastering engineers often place a high pass filter within the compressor's side-chain circuit. This filter removes low frequency content, and allows one to remove problematic low-end frequencies before they reach the compressor's amplitude detection mechanism. By reducing the amount of low-frequency information present in the compressor's detection circuit, the risk of prematurely causing gain reduction is significantly lessened.

Audio Example

Audio example 2.2.4 illustrates sidechain filtering. At first, the track is compressed according to the heavy compression strategy described earlier in this chapter (Ratio: 4:1; Threshold: Medium to High; Attack: 10ms/Fast; Release: 100-300ms). The second segment of this example (00:15) applies sidechain filtering to cause the compressor's detection unit to ignore

frequencies below 100 Hz. Abundant low frequency information is often incorrectly interpreted as excessive amplitude by detection circuits, so this approach ensures that the extra low frequency information does not reach the detection circuit. Thus, the first portion of this example (00:00-00:15) is more compressed than the second portion (00:15-00:30)

Hypercompression as an Aesthetic Tool

Hypercompression, the term engineers use to describe overly compressed signals, is typically blamed for the *loudness wars* discussed in Chapter 1 (Deruty & Tardieu 2014: 43). A number of engineer/researchers dislike the practice of over-compressing signals during mixing and mastering, and claim that the results of such hypercompression always negatively impacts a record's sound quality (Katz 2007; Milner 2011; Vickers 2010). For instance, as Bobby Owsinski warns (2008: 34-5):

Over the years it has become easier and easier to get a record that's hotter and hotter in perceived level, mostly because of new digital technology that has resulted in better and better limiters. Today's digital "look ahead" limiters make it easy to set a maximum level (usually at -.1 or -.2 dBFS) and never worry about digital overs and distortion again, but this usually comes at a great cost in audio quality.

Too much buss compression or over-limiting, either when mixing or mastering, results in what's become known as *hypercompression*. Hypercompression is to be avoided at all costs because:

1. It can't be undone later.
2. It can suck the life out of a song, making it weaker-sounding instead of punchier.
3. Lossy codecs such as MP3 have hard time encoding hypercompressed material and insert unwanted side effects as a result.
4. It leaves the mastering engineer with no room to work.
5. It's known to cause the listener fatigue, so the consumer won't listen to your record for as long, or as many times.
6. A hypercompressed track can actually sound worse over the radio because of the behaviour of broadcast processors at the station.

Ronan *et al* (2016) note recently that “sound quality” is poorly defined within available research on hypercompression, and to rectify this lacuna, they proceeded to test the subjective impacts of hypercompression on listeners. Based on attributes test subjects described in their study, they found that hyper-compression could negatively impact a record’s perceived clarity, energy, feeling of space, brightness/darkness, fullness/thinness, and general instrumental levels (Ronan *et al* 2016: 43).

Although hypercompression negatively impacts the sonic categories listed above, researchers rarely discuss instances where hypercompression is adopted as a foundational aesthetic tool. An exception is found in Hodgson (2011), who is the first researcher to analyze compression as a musically communicative device. In other words, Hodgson argues that compression is an integral aesthetic component of some types of recordings. For example, he notes that sidechain compression is used in hip hop music in order to enhance a song’s groove through the creation of recurring amplitude pumping effects.

On experimental hip hop records, such as Flying Lotus and Madlib releases, hypercompression often occurs when sidechain compression is compounded with compression/limiting that has been added during mixing and mastering (Hodgson, 2011; Shelvock, 2017: 179). In fact, hip hop favours hypercompression to the extent that labels have recently been warned their releases may be rejected in the UK due to new European broadcasting standards. As mastering engineer Crispin Murray offers (in Hepworth-Sawyer & Hodgson, forthcoming):

Things are inevitably louder these days, but not everything has to be louder. I think loudness is an issue in its own right. The issue is ultimately being addressed by our 128 standard for broadcast. I’m told the BBC has already told some — I don’t want to say Rap acts — but people that have minimal structure within their music and can therefore get it absurdly loud. BBC has more or less rejected these cuts, and said if you master it properly they will playlist it. If the cut remains loud, however, they won’t play it because it sounds like they’ve made a broadcast mistake.

Indeed, as Murray states, hip hop prizes the sound of hypercompression to such an extent that the recordings violate the *suggested* UK broadcast standards. Yet the sound of hip hop does not seem to have changed despite the implementation of loudness recommendations for broadcast, such as R 128.⁸⁸ Kaytranada’s recently released track “Glowed Up” (2016, feat. Anderson Paak), for instance, exemplifies an intentionally hypercompressed sound even though loudness researchers claim microdynamics are returning to recordings (Deruty & Tardieu 2014: 43). The song features audible distortion (clipping) at times when the kick drum is played, for instance.

Audio Example

Audio example 2.2.5 demonstrates the creative use of hypercompression. On hip hop records, sidechain compression is a foundational technique. As a result, when tracks from this genre receive DRC at the mastering stage, sidechain pumping is compressed even more. When this occurs, the subsequent master can contain moments of hypercompression. While some engineers warn against this type of treatment, such as Bob Katz, it remains a prevalent aesthetic on hip hop records (Shelvock 2017:179).

⁸⁸ Please see the Chapter 1 subheading entitled “Loudness” for more information on this broadcast standard.

Chapter Three

Designing Timbre

For recordists, timbre describes the overall sonic quality, or *colour*, of a record (Cousins & Hepworth-Sawyer 2013: 92). Materially speaking, timbre results from a sound's distribution of spectral energy over time (Grey 1977: 1270-1277). Although timbre is a sonic feature of both live and recorded performances, scholars generally agree that its aesthetic relevance is more prominent on recordings.⁸⁹ Unlike live performances, recordings offer a precisely repeatable timbral profile. Mark Katz explains (2004: 24-25):

Sing a single note. Now try to recreate that sound exactly—not simply its pitch, but its precise volume, length, intensity, timbre, attack, and decay. Now imagine trying to repeat an entire song in this way, down to the smallest detail. It simply cannot be done. The impossibility of such an exercise reveals what is perhaps the most unbridgeable difference between live and recorded music: live performances are unique, while recordings are repeatable.

Live music is in fact repeatable, but in the form of works, not performances. That is, any orchestra can play Beethoven's Fifth Symphony many times; each performance, however, will necessarily be different. Second, to say that a recorded performance is repeated without change is not to deny that a listener may experience a recording differently from one hearing to another, whether by adjusting the playback equipment or by focusing on different aspects of the music. I mean only that the actions that created the sound one hears on a recording are fixed, and do not change when the recording is replayed.

Indeed, records present listeners with the same timbral profile each time they listen, whereas live performances simply cannot do so. As a result, music production researchers now incorporate the discussion of timbre as a crucial theoretical element (see especially, Cousins & Hepworth-Sawyer 2013; Draper 2013; Hodgson 2010, 2014; Katz 2004; Moylan 2007; Shelvock 2017).

⁸⁹ For further discussion, see: Cousins & Hepworth-Sawyer (2013), Golding & Hepworth-Sawyer (2010), Hodgson (2010, 2014), Izhaki (2008), Katz (2004), Moylan (2007), Zagorski-Thomas (2013).

In an ontological sense, this ability to precisely recall a timbral profile at any time further distinguishes records from live performances. Jay Hodgson (2014: 90) considers some of the aesthetic consequences presented by this ontological difference:

Few realize that Recording Practice comprises a kind of stopmotion animation for sound. Every technical phenotype of storage medium, from wax cylinders to the Voice Memo app on your iPhone, stores discontinuous packets of data called samples. Film provides a useful analogy here. Video cameras— analog and digital phenotypes—generate discrete snapshots quickly enough that, when they are displayed in sequence and at the same rate they were encoded, the images seem to animate, taking on an illusory life beyond empirical two-dimensionality. Animated images don't actually move, of course, and sound waves don't actually undulate on records. Records contain sequences of samples that aurally portray sound waves in various states of propagation and decay. Once we record you plucking the second-lowest string on your acoustic guitar, for instance, we can always scrub past the first three seconds to hear the exact same guitar timbre in precisely the same state of decay, and according to the same precisely fixed acoustic and psychoacoustic variables (we can always skip the first three seconds' worth of samples, in other words). We might even replace a few samples we don't like with other samples, using the "sample replace" function on whichever DAW we use. We don't hear the plucking of an acoustic guitar when we play the record, after all, and we don't hear an A below middle-C propagate and decay.... what we hear are discrete samples, each depicting a different moment of propagation and decay. All motion in media is an animated illusion; mediated images and sounds only seem to move, only seem to propagate and decay. Motion can only be represented in Recording Practice, never achieved. And motion is represented only by sequencing samples at very precise rates.

In this quotation, Hodgson suggests that records represent musical activity in a manner analogous to stopmotion animation. For instance, a record may conjure the illusion of a band playing a song, yet this performance never actually occurs. Engineers often carefully craft records to be *realistic*, or otherwise *believable*, sonic artifacts, and as such, when listeners believe that a particular record *sounds like* a band playing a song, the illusion stems directly from the contributions of skilled engineers. If there are no recordists, there are no records (Hodgson 2014: 93).

Hodgson's ontological characterization of the recording arts also stresses the importance of timbre. Timbre is not a fleeting or anecdotal component of record playback, for it is actually a foundational component of a record's psychoacoustic profile, part-and-parcel of the musical communications recordists represent. Although one might audition a record

though a variety of speakers or headphones, a frequency analysis of the record itself always reveals the same timbral profile. Hodgson continues (2014: 31-34):

Psychoacoustic profiles don't modify recorded sound. They remain an integral property, a holistic part and parcel, of such sounds. Listeners cannot disentangle a recorded snare drum hit from its reverberations, for instance, whether those reverberations were captured during a live tracking session, synthesized, or applied during mixdown using signal-processing techniques. We might move to the left or right of our speakers, or even walk between and through them, but the snare drum remains fixed wherever the mix engineer positioned it. Likewise, we might put on a pair of headphones and run a city block, but the snare drum nevertheless stays forever put.

Indeed, as Hodgson concludes, a record's finalized psychoacoustic profile cannot be altered, or superseded in any way. Thus, on records, timbre cannot be analytically divorced from what some might call the "musical content."⁹⁰ In other words, a record cannot playback a rhythm, melody, or harmony of any type without also conveying timbre. To this end, records have already been heard for us. Recorded sounds are conveyed to listeners from the sonic perspective of a "hypothetical auditor" (Hodgson 2014: 36). While other recordists contribute individualized sonic perspectives to a record, mastering engineers routinely collate and reconfigure their sonic inputs. Thus, mastering engineers *hear* records *for* listeners, long before these records are available for distribution.

Although timbre remains fixed on records, there are times when a master will be revisited in order to reconfigure its timbral qualities, implying that listeners are aware of, and care about, the role that mastering plays in the records they hear. In fact, in the recording industry, sonically restructured — or *remastered* — records are sold separately from their original versions. When the psychoacoustic properties of a previously mastered record are significantly altered and re-released, this process is called *restoration* or *remastering*.

Restoration typically refers to the act of sonically re-shaping a record previously released in a

⁹⁰ Here I use "musical content" to refer to commonly agreed upon components of music. Many of these components are typically communicated via standard notation, such as rhythm, dynamics, melody, and harmony.

non-digital format, such as vinyl or tape, where the source material demonstrates a narrow dynamic range and bandwidth. In these cases, timbral issues simply derive from outdated sonic practices and technologies, or poor storage techniques, and mastering engineers are tasked with optimizing an older record's spectral and dynamic properties for playback on current digital equipment. Remastering, on the other hand, refers to any fundamental reconfiguration of a record's sonic characteristics, and records may be remastered at any time. In 1990 Led Zeppelin issued *Led Zeppelin Remasters* (7567-80415-2: 1990) to CD — discs that offer digitally remastered versions of tracks originally released between 1968 and 1978. In 2015, Led Zeppelin published digitally remastered material once again in a boxed-set. On the 2015 remastered version, guitarist Jimmy Page remarks (in Christ 2015):

What happens is, with these albums [is] that you find that the first test pressings are pretty good, but once they get them on the production line, then the quality, sort of, it starts to disappear a bit — or lack. With all of the advance of technology, that has sort of, preceded the point that we can ... that I can revisit the albums and re-cut them; then it gave the opportunity to give the best possible quality at this point. And really, actually — by hi-fi standards, this in, like reviews in hi-fi magazines — [they say] they're better than what the original ones were; which of course, that's always the object of the exercise.

As Page notes, rapidly improving sound reproduction technology encourages the remastering of previously recorded material. Even though Led Zeppelin's 1990 and 2015 CD remasters both take advantage of digital technology, digital production practice also changed dramatically over those 25 years. As a result, to maintain market relevance, Page (*et al*) felt the need to remaster and re-issue the record once again in 2015.

Page's account also reveals the goal of remastering: to create a *better* sounding record than earlier versions. In part, this includes reconfiguring the original master's timbral profile according to current standards for fidelity and resolution. Older sound recording equipment (and storage media) are simply incapable of reproducing the dynamic range and frequency bandwidth available on modern digital systems. Thus, many records are remastered to take

advantage of enhanced sonic reproduction capabilities.

Whether mastering or remastering, engineers actively consider the nature of human hearing, as well as the reproduction characteristics of playback equipment, when finalizing a record's timbre. A large part of this work requires engineers to ensure that an acceptable frequency balance is heard on the remaster. Although a track with an abundance of frequency information between 10 and 20 Hz may sound interesting or unique in a well-equipped studio, it is unlikely that any of this sub-bass energy will be audible through common laptop and cell phone speakers (Cousins & Hepworth-Sawyer 2014: 92). As a result, mastering engineers ensure that a record's timbral profile can be reproduced on available devices.

Despite the existence of numerous technical and physical constraints, timbral manipulation during audio mastering is actually a sophisticated creative affair, and no standard rubric or meter describes an ideal spectral balance. As Mark Cousins and Russ Hepworth-Sawyer remark (2014: 92):

Put simply, timbre is one of the big variables of music production — a light 'acoustic' ballad might have an airy timbre with plenty of highs, whereas a hard-hitting piece of dance music will often have a dominant, heavy low-end.

Indeed, as Cousins and Hepworth-Sawyer conclude, the consideration of timbre is a crucial concern for recordists, even though no standardized template instructs timbral representation on records. That said, engineers often remark that records should sound like other records, and these researchers (2013: 92) remark:

While it's important to retain the individual sonic identity of a track, mastering engineers recognize that it's also beneficial to have some degree of uniformity to the sound of recorded music, even between stylistically contrasting sources. A deep and pleasantly extended bass, well-rounded mids and nicely defined high-end generally makes for a pleasant and musically effective listening experience, allowing the music to be conveyed in its best possible form.

Thus mastering engineers balance the aesthetic requirement for a record to sound somewhat *unique*, with the quasi-curatorial duty of altering masters to sonically resemble other records. However, the steps taken to accomplish this task vary based on the source material, as do the

methods engineers use to equalize records. I examine the most prominent methods of spectral alteration in the following section.

Equalizers, Frequency Ranges, and Achieving *Balance*

Equalization (EQ) provides the most direct method for modifying timbre during audio mastering, even though engineers often use compressors, saturators, inflators, and other devices for the same purpose. In addition, a number of other devices, such as dynamic EQs and de-essers, also configure a signal's timbral components. These devices attenuate (or, more rarely, boost) a user-defined frequency region when an amplitude threshold is exceeded. Beyond these tools, mastering engineers use less predictable methods of timbral alteration, such as saturation and distortion, although they do so less frequently. The following sections discuss each of these timbral shaping devices: EQ, M/S EQ, saturation, distortion, clipping, excitation, multiband compression, and dynamic EQ.

EQ

An equalizer (EQ) is a device that allows one to alter a signal's frequency response through the application of filters. When engineers apply EQ, specified regions of the audio spectrum are boosted or attenuated via these filters (Houghton & White 2008). Although EQs can boost or cut a designated spectral region, they are primarily used to attenuate excess frequency energy during audio mastering. Quite often, when undesirable frequency information is reduced, spectral regions that previously sounded weak may suddenly sound well balanced. And engineers, of course, are cautious when applying gain with an EQ, as the application of gain increases a track's overall level, taking up valuable headroom.⁹¹ Another reason to

⁹¹ As mentioned in Chapters 1 and 2, digital records should avoid exceeding 0dbFS.

remain cautious while applying standard EQ boosts (as one does in mixing, for example) is that EQ can sound “unnatural,” or overly disruptive to the records initial balance, when applying broadband boosts.

Since mastering engineers usually apply EQ cautiously, they evaluate a record’s timbral distribution before altering its frequency balance. In order to perform this evaluation, engineers divide the audible frequency spectrum into three main conceptual zones (Figure 3.1.1): low frequencies (LF; 0-150Hz), middle frequencies (MF; 200Hz-6,kHz), and high frequencies (HF; 7-12 kHz) (Cousins & Hepworth-Sawyer, 2013: 102-107).⁹²

Figure 3.1.1: Equalizer Example, Logic X Native EQ

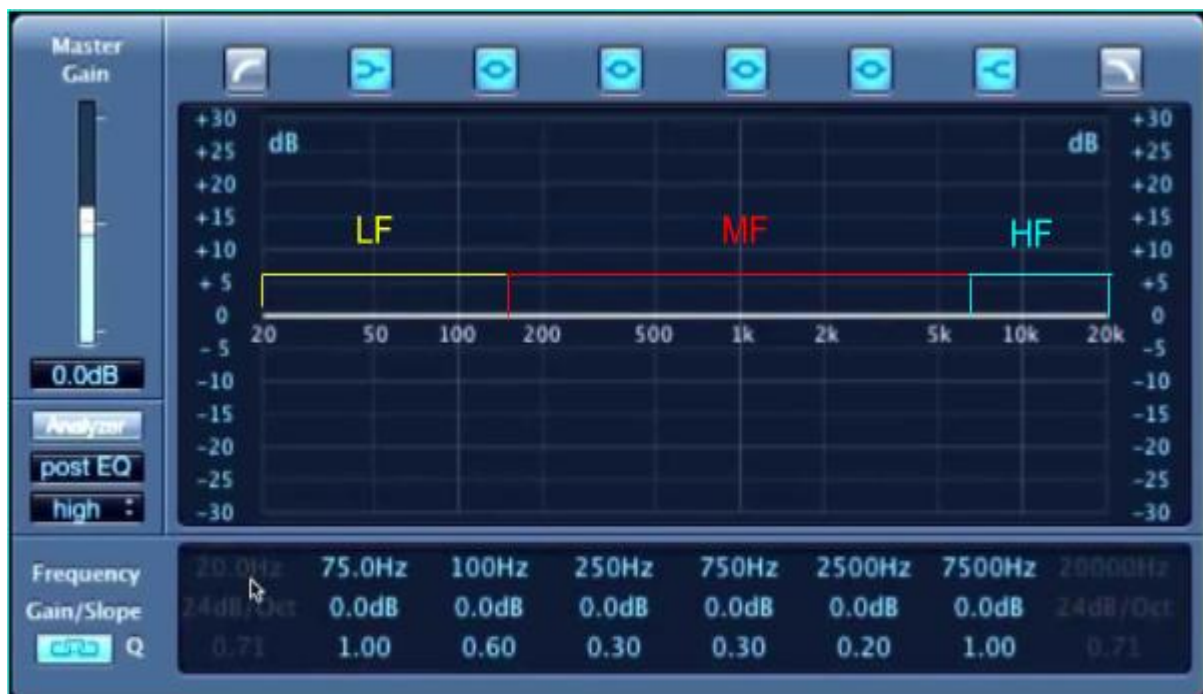

⁹² At the time of writing, no consensus exists for defining the boundaries of low, mid, and high frequencies. As a result, I simply reproduce the definitions used in Cousins & Hepworth-Sawyer (2013).

Figure 3.1 shows a typical digital EQ. LFs (yellow) are visually controlled (and monitored) on the left side of the EQ's graphic user interface. Accordingly, MFs (red) are controlled (and monitored) using the middle region of this graph, and HFs (blue) are controlled (and monitored) using the right side of this graph.

Audio Example

Audio example 3.1.1 demonstrates the general sonic character of each of these frequency regions. To exemplify this, I apply different filters to a white noise track.⁹³ First, I remove MF and HF content within the signal in order to highlight LF content. Using the same method, I proceed to highlight MF (00:15) and HF (00:30) regions respectively.

Low Frequencies

The LF zone contains a track's sub-bass region (defined as 10-60 Hz) as well as its low frequency information (60-150Hz). Commonly heard sounds which feature prominent LF energy include acoustic kick drums, the fundamental frequencies of low bass guitar notes (i.e., 4th string, E is 41.2Hz; 3rd string, A is 55.0Hz), 808 kick drums and basses,⁹⁴ synthesized *sub-basses* of any type, and other similar low-frequency rumbles.

⁹³ White noise is a randomly generated signal that features equal intensity across the audible frequency spectrum.

⁹⁴ The 808 is a drum sequencer produced by Roland between 1980 and 1983.

Audio Example

Audio example 3.1.2 provides examples of LF-rich instrumentation. For this demonstration, I selected LF sounds which are rarely heard in isolation on records, such as two different kick drums, two different sub-basses, a bass synth, and a bass guitar.

In a practical sense, excessive sub-bass frequency information requires a large amount of headroom. To reduce this excessive LF energy, mastering engineers usually employ a high-pass filter (HPF), positioned according to the spectral design of the track being mastered, and the record's intended aesthetic outcome (recordists typically apply the filter in the 20-40 Hz range).

Audio Example

Audio example 3.1.3 applies various HPF settings to one of my original tracks. I first place the HPF at 40 Hz, and at 00:15, the HPF is set to 60 Hz.

As Cousins & Hepworth-Sawyer explain (2013: 103), engineers alter a record's frequency characteristics based on the audio's intended function:

...consider the relative merits given your end destination. As one example, a soundtrack on a TV has a different sonic objective to that of a film soundtrack played in the cinema. Differentiating between these two applications, therefore, might best ensure your music is presented as effectively as possible.

Since engineers treat film soundtracks separately from Beatport singles or vinyl releases, mastering engineers individualize their timbral treatment accordingly.

Common sonic elements, such as kick drums, bass guitars and bass synthesizers typically contain an abundance of energy between 60 and 150Hz (in addition to sub-bass information), and unlike a track's subsonic region (e.g., 0-60Hz), this spectral area often contains a song's harmonic (e.g., chordal) foundations (Cousins & Hepworth-Sawyer 2013: 103). This is an important consideration for mastering engineers who work on styles of music that feature a bass line of some type (or bass instrumentation). However, when mixes feature excessive energy between 60 and 150 Hz, and this tends to produce a *muddy* or obfuscated record.

Audio Example

Audio example 3.1.4 demonstrates the sound of a distorted *low-end*, so that listeners can identify this deficiency aurally. In addition, this example also demonstrates what engineers might call a “muddy” sound. After 30 seconds the LF content is effectively tamed.⁹⁵

Middle Frequencies

Generally speaking, instruments and the voice provide a record's middle frequency (MF) content, and engineers typically divide this portion of the frequency spectrum into three parts: low mids (200-500Hz), mids (500Hz-1kHz), and high mids (2-6kHz). By addressing the low mids (200-500Hz), engineers alter a signal's warmth characteristics, so to speak (Cousins &

⁹⁵ Mastering engineers typically ensure that issues of this nature are not present in the final version of a record. Examples such as 3.1.4 demonstrate sonic deficiencies that are never heard by anyone other than recordists.

Hepworth-Sawyer 2013: 105).⁹⁶ Numerous instruments produce spectral energy in this region — guitars, pianos, and cellos. Thus, a track’s instrumental arrangement greatly impacts the accumulation of frequencies in this area, and skilled producers, mixers, and arrangers try to avoid cluttering the the low mids.

Audio Example

Audio example 3.1.5 demonstrates the manipulation of low mid frequency content. The first 15 seconds of this track feature exaggerated low mid frequency content. At 30s (00:30), the low mids are reduced significantly. At 45s (00:45), the track demonstrates a balanced low-mid range region.

Humans hear the middle frequencies that lay between 500Hz to 1kHz particularly well and small spectral alterations to this region tend to yield starkly noticeable results (Cousins & Hepworth-Sawyer 2013: 105). In addition, the pitch content (i.e., fundamental frequency, or f_0) of many songs falls within this frequency range, which corresponds approximately with pitches C3 through C5 (Cousins & Hepworth-Sawyer 2013: 105). Thus, any spectral enhancement that addresses 500Hz-1kHz may also modify the prominence of a song’s pitch content by directly foregrounding (or attenuating) a recording’s fundamental frequencies.⁹⁷

⁹⁶ “Warm” is a colloquial term engineers often use to describe low-middle frequencies (see Katz 2007: 47).

⁹⁷ A fundamental frequency is the lowest frequency of a periodic waveform. In music, fundamental frequency (i.e. f_0) refers to a note’s pitch (Moore 2013: 4).

Audio example 3.1.6 exemplifies mid-frequency boosting. To do so, I add several dBs of gain to the region around 1 kHz. Listeners will hear that the track's pitch content becomes more prominent as these frequencies are foregrounded. The first 15s of this track features a deficient midrange. For comparison, the next segment (00:15-00:30) restores the midrange.

A record's overall definition — or *bite*, as engineers often refer to it— is expressed in the high-middle frequency range (i.e. 2-6kHz).⁹⁸ Mastering engineers pay close attention to these frequencies because lower quality monitors do not reproduce them well. Moreover, an abundance of energy in this region can cause a track to sound harsh or *fatiguing* (Cousins & Hepworth-Sawyer 2013: 107). As a result, high quality mastering monitors provide a neutral or *flat* frequency response to allow engineers to hear such deficiencies better. This ability to objectively evaluate a track's entire frequency distribution is, of course, imperative to the goals of audio mastering. And such objective assessment of high-middle frequencies has perhaps never been more crucial, as nearfield monitors with poor upper-middle frequency representation are very common in today's project studio environments (Cousins & Hepworth-Sawyer 2013: 107).

⁹⁸ Engineer-researchers Mark Cousins and Russ Hepworth-Sawyer explain that altering a record's high mids (2-6kHz) can drastically affect its clarity (2013: 107). However, excessive high mids sound harsh (Katz 2007: 47). When this frequency range is too abundant in a signal, engineers say that the sound exhibits too much "bite." In addition, this frequency zone is much louder than the others. In fact, the loudness evaluation recommendations made in ITU-BS.1770 suggest that this region receives a higher loudness weighting (e.g., k-weighting) than lower frequency regions (4: 2017).

Audio Example

Audio example 3.1.7 was mixed on subpar monitors with poor crossover representation. The first 15 seconds of this example has a harsh overall sound that primarily results from an abundance of high mid frequencies. The next section (00:15-00:30) reduces high mid frequencies to correct this harshness. However, too much *bite* has been removed, which causes the track to sound dull. At 00:45, an evenly distributed high mid frequency balance is achieved.

In contrast to the lower-mid frequency bands, the high-mids tend to contain more overtone content rather than distinct pitches (for example, the highest note on a piano tuned to A=440 is 4,186 Hz; Cousins & Hepworth-Sawyer 2013: 107). Boosts in this region tend to foreground vocals, guitars, and snare, as well as EDM sound effects (such as risers and impacts demonstrated in audio example 3.1.8 below). In addition, distorted instruments, including guitars and synthesizers, also often create rich high middle frequency overtones; thus, high-mid boosts can also accentuate these sounds on a record. Cuts in this region, on the other hand, typically have the opposite effect, and engineers adopt either approach depending on the desired timbral outcome.

Audio Example

Audio example 3.1.8 demonstrates typical EDM sound effects in isolation and within a mix. The first 30 seconds feature various risers and impacts. After a fadeout, the next segment highlights these sounds in various contexts.

Audio example 3.1.9 shows how boosts and cuts to a track's high midrange region alter the expression of typical electric guitar distortion. Listeners are presented with an isolated electric guitar, and in the first segment, high-mid frequency content is reduced with an equalizer, but the second part restores the high-mid frequency content.

High Frequencies: Treble and Air

Engineers refer to frequencies between 7 and 12kHz as the *treble* frequencies, and this zone contains the majority of a track's transient information (Cousins & Hepworth-Sawyer 2013: 107). As such, the treble zone greatly impacts a recording's overall sense of detail. Some familiar timbral components that are expressed in this frequency range are the *sizzle* of a cymbal, or the extra *brightness* that emanates from new guitar strings (Cousins & Hepworth-Sawyer 2013: 107). However, if too much treble is present on a record, it will sound quite harsh. Mark Cousins and Russ Hepworth Sawyer comment on the treatment of these frequencies (2013:108):

Within the treble frequency spectrum there are also a great deal of different colours to play with. While most engineers plump for 10kHz as the default frequency, you can also extract some interesting sonic variations either side of this line. 7kHz, for example, is a useful place to start a lift if your source is lacking HF detail. 12kHz, on the other hand, has a lighter sound to it, by virtue of it being slightly higher up the audio spectrum. If your source has plenty of [high frequency] extension, a 12kHz boost has a cleaner sound, enhancing the detail with a little less 'edge' than at 7kHz.

As with sub-bass, the region between 12-20kHz – known as *air* frequencies – provide listeners with more of a physical sensation, rather than clearly audible timbral components (Cousins & Hepworth-Sawyer 2013: 108). This is because, in part, human hearing is significantly less sensitive above 10kHz (Cousins & Hepworth-Sawyer 2013: 108). However,

when engineers boost a track's *air* characteristics, this can often establish a sense of increased *realism*. By realism, I refer to the extent to which a given recording resembles natural, or live sound. Non-recorded sounds exhibit a fuller frequency range than recordings can reproduce, and this is especially true of high frequency content.⁹⁹ Boosting a track's *air* can establish a more realistic effect by highlighting the high-energy frequency bands that arrive at the listener's ears first, before lower-energy spectrum (e.g., 20Hz-12kHz; Moore 2013: 25-30).

Shaping Fundamental Frequency and Upper Harmonics via EQ

In material terms, all sounds consist of a fundamental frequency and component harmonics that exist in integer multiples of the fundamental frequency (or F0; Grey 1977: 1270-1277).¹⁰⁰ As discussed, a sound's overtone series determines its timbral characteristics. Instruments produce harmonics that are integer multiples of the fundamental frequency (or, intended pitch), such as the recognizable timbres heard when voices, pianos, and guitars are played. Sounds of a more complex overtone makeup, such as drums, instead feature harmonics which deviate from simple integer multiples of the fundamental frequency (Cousins & Hepworth-Sawyer 2013: 118).

Because of the physical nature of musical timbre, engineers can use equalizers to shape the *colour* of recorded sounds. However, mastering engineers must be particularly careful when applying EQ, because all boosts and cuts are applied globally in mastering (unlike mixing, wherein individual components can be addressed). In order to reconfigure the balance of specific instruments (or other sounds) during mastering, engineers attempt to

⁹⁹ For example, consider how frequency content within a sound source degrades as it passes through a microphone, cables, pre-amps, and convertors, because each of device's spectral bias.

¹⁰⁰ In this chapter, I use the terms harmonic, overtone, and partial interchangeably, as do most music production scholars and authors of audio engineering texts. However, I also use the term "harmonic" to refer to chordal harmony in a few instances throughout this dissertation. Typically, these uses of the term are paired with the discussion of other commonly discussed musical elements, such as melody, in order to avoid confusion.

identify and modify the spectral region associated with these instruments. For instance, an engineer might program an EQ to attenuate the region containing the fundamental frequencies of a certain instrument, while boosting an upper partial to bring out the instrument's *attack* qualities.¹⁰¹

Audio Example

Audio example 3.2.5 tames the region around 5 kHz in order to control some excessively harsh trap-style hi-hats. The example plays without modification (00:00-00:15), before I apply de-essing (00:00-00:30) to reduce energy around 5 kHz. Next (00:30-00:45) a gentle high-shelf boost is applied to bring out the attack of these hi-hats, while leaving the region around 5 kHz reduced. This maneuver tames the harshness in the signal while simultaneously allowing transient detail to remain foregrounded.

In other situations, however, recordists may wish to consider the 2nd harmonic of an instrument's (or sound's) pitch. Engineers simply double the fundamental frequency of a targeted sound or instrument in order to locate its second harmonic (i.e. $2F$). A mastering engineer may notice within a mix, for example, that the bass guitar track plays pitches with fundamental frequencies falling between 41-55 Hz . Boosts in this area, however, may cause the mix to sound *muddy* or overly bassy. Indeed, an overly bassy record will react unfavourably to dynamic range compressors, and thus, engineers carefully avoid allowing too much energy to build up in this region. Instead, one might boost the frequencies around 82-

¹⁰¹ For engineers, *attack* refers to the onset (or transient) of a sound event. For more information, please see Chapter 2 on attack and release.

110 Hz (second harmonic), 246 Hz-330 Hz (third harmonic, $3F$), or perhaps even 328- 440 Hz (fourth harmonic, $4F$) in order to increase the listener's perception of bass frequency content (Houghton & White 2008). Mark Cousins and Russ Hepworth-Sawyer outline two reasons to focus on a sound's second harmonic, as well as other upper harmonics, when applying EQ (in 2013: 119):

Boosting the second harmonic rather than the fundamental is useful for several reasons. Firstly, you potentially avoid any instruments that might coexist in the same part of the frequency spectrum, which is always an issue with corrective equalization moves that are applied across a master as a whole. Secondly, by being further up the frequency spectrum, you can potentially help an instrument articulate itself over a smaller pair of speakers, which is always an issue for bass instruments with deep fundamental frequencies.

Indeed, engineers focus on a target sound's second harmonic — and perhaps other upper partials — in order to avoid unpleasant peaks in frequency distribution. In fact, ubiquitous consumer electronics such as laptops, iPod speaker docks, and ear buds feature small speakers that are incapable of reproducing frequencies below 150 Hz well. Engineers may boost the second or third harmonic of the bass guitar to enhance a record's bass response for playback on these systems (Houghton & White 2008; Cousins & Hepworth-Sawyer 2013: 119).

Audio Example

Audio example 3.2.6 boosts the track's fundamental bass frequencies (00:00-00:15), and then boosts the region around the bass's 2nd harmonic (00:15-00:30). The final segment boosts the 3rd harmonic (00:30-00:45). The first boost disrupts the available headroom of the track, because (as discussed in this chapter's section on low-frequencies) bass frequencies require more energy to propagate. However, the 2nd and 3rd boost cause the bass to sound more

prominent without occupying as much headroom as the first boost.

High-Pass and Low-Pass Filters

The simplest equalization devices are single-band EQs called high-pass filters (HPF) and low-pass filters (LPF). To use these devices, users must specify a *corner frequency*. Spectral data which falls below this range is muted when using an HPF. The LPF also designates a corner frequency, but instead mutes frequencies above this adjustable setting. The electrical topology of the HPF and LPF can be quite simple, as Paul White and Matt Houghton explain (2008):

The simplest equaliser consists of just one capacitor and one resistor. With the resistor in series and the capacitor linking the output to ground, you get a high-cut (alternatively, 'top-cut' or 'low-pass': they all mean the same thing) filter that's just like the tone control you find on an electric guitar — that is to say, one that filters out the higher frequencies. Putting the capacitor in series and the resistor to ground gives you a low-cut (or 'high-pass') filter, that cuts out lower frequencies .

Software designers emulate these hardware LPFs and HPFs within the digital domain. These plug-ins often specify a corner frequency and have a *strength* control that is measured in decibels per octave. For example, a 6 dB strength curve is relatively weak compared to 12 or 18 dB curve (Cousins & Hepworth-Sawyer 2013: 99).

Audio Example

Audio example 3.2.1 demonstrates the sound of a HPF slowly *sweeping* up and down the entire audible frequency spectrum (20Hz-20kHz). The HPF is applied so that listeners can hear the effects of high pass filtering applied on a composition.

Shelving Filters

The passive filters just discussed mute frequency bands instead of boosting them, and when broad frequency boosts or attenuations are necessary in the low or high frequencies, engineers use shelving filters (White 2001). Users normally specify a frequency cutoff point, and all frequencies above (or below) this point can be boosted or attenuated depending on the desired result. In addition, these filters feature a gradual boost/attenuation curve around the specified cut-off frequency. This graduated curve causes boosts and cuts applied via shelving filters to sound less artificial (White 2001).

Audio Example

Audio example 3.2.2 exemplifies the difference between a shelving filter and a narrow boost. First, a narrow boost is applied at 10 kHz. However, the result is not as desirable as the second segment, which begins at 00:15, where a high-shelf boost provides a more subtle increase across neighbouring frequencies.

Parametric Equalization and Peaking Filters

When more exacting equalization is required, engineers can apply either peaking or parametric equalization filters. *Peaking filters*, unlike the shelving variety, feature both sweepable frequency and gain controls. In addition to these filters, *parametric* EQs also feature a user-specified Q control that determines the width of any boost or cut. Engineers employ the parametric device to select a desired frequency and then boost (or attenuate) that frequency along with neighbouring bands. The extent to which adjacent frequency areas are

altered is a product of the Q value, which can be raised or lowered in order to process a larger or smaller range of frequencies.

The term *parametric equalization* was popularized in an Audio Engineering Society paper written in 1972 by George Massenburg. On the advantages of this design, Massenburg explains (in 1972: 6):

The Parametric Equalizer is an appropriate compromise between a three-knob switched frequency equalizer, a graphic equalizer, and a program equalizer; and adds the capability for automation. The equalizer can produce a very sharp notch, like a graphic [EQ], and hold the shape over various depths to remove, say, the low frequency resonance in an acoustic guitar being picked up by a cardioid microphone. In its broadest position the equalizer looks broader than most broad peaks in peaking equalizers. It can produce a peak at any frequency and shape and contour its effect to match an anomaly to be removed. Although a three-band model cannot construct as complex a characteristic as a graphic, its variable shape and frequency let it come closer to an average correction than a typical equalizer. And it is much faster than a graphic in that one can hear the peak being swept through the point of correction, and one can accurately and quickly judge the frequency and amount of correction needed. Its curves are broad enough so that the mid-section can apply a broad boost to the upper mid-range, while the high frequency section can apply a sharp dip to remove vocal sibilances concentrated around one frequency. The unit can simulate perspective effects, like loudness contours, accurately.

Audio Example

In audio example 3.2.3, I place a parametric EQ filter at 1 kHz, and then I sweep through the device's Q -setting. As the q -value increases, the filter acts upon a wider range of frequencies centered on 1 kHz.

Graphic EQ

Graphic EQs provide discrete gain control of up to 31 individual frequency bands, and these frequency bands each account for $\frac{1}{3}$ of an octave within the audible sound spectrum.

Engineers, however, use these devices infrequently, primarily because the graphic EQ's relies

on a *fixed-Q* setting, unlike the adjustable Q available on parametric EQs (Cousins & Hepworth-Sawyer 2013: 99). Although the graphic EQ allows a high degree of control over each adjustable frequency band, this is not necessarily desirable during audio mastering. In fact, engineers cannot generate broad boosts and cuts using a graphic equalizer without also causing individual peaks at each frequency band. For instance, although graphic EQs offer 31 controllable frequency bands, the resulting division between bands sounds rather *coarse* because of the lack of sweepable frequency controls on this device, as well as the lack of an adjustable Q value (Cousins & Hepworth-Sawyer 2013: 99). Thus, graphic EQs are less suitable for mastering records.

Audio Example

Audio example 3.2.4 applies narrowband boosting at various frequencies with a graphic EQ. The first boost is at 80 Hz, and occurs between 00:00-00:15. The second segment (00:15-00:30) places a boost at 500 Hz, while the final segment (00:30-00:45) boosts 1 kHz.

Dimensional Timbre: Unlinked (L +R) and Mid/Side Equalization

Equalization is typically applied to both left and right channels simultaneously. However, by simply *unlinking* these channels, recordists can alter the left and right signals separately. If a mastering engineer receives a mix with an overly loud splash cymbal in the right speaker, for instance, then an EQ operating in *unlinked* mode can attenuate excessive brilliance (approximately 6-20 kHz) in the right speaker on its own.

In fact, some equalizers can reconfigure a signal's frequency distribution throughout the entire stereo field. These devices/plugin-ins are known as mid/side processors (M/S). When engaged, M/S processing allows engineers to discretely access a stereo signal's *mid* (middle)

and *side* audio information. M/S encoding routes stereo information that emanates from both speakers equally to a *mid* channel. Conversely, the *side* channel only contains audio information that differs between the left and right speakers (e.g., uncorrelated audio). Thus, M/S processors allow users to process the *sum* of the left and right speakers separately from the *difference* portion of these two signals (Dow 2011).¹⁰²

In a practical sense, with M/S EQ one can alter the spatial aspects of a record's spectral presentation. One common application involves the spatial reconfiguration of bass frequencies. Low-end spectral content often benefits from mono presentation, and engineers apply M/S EQ to reduce the stereo width of bass frequencies. On this phenomenon, *Sound on Sound* engineer Rory Dow offers (2011):

It's accepted as standard practice that low- frequency instruments such as kick drums and bass should be kept in the centre of the stereo field. There are a couple of reasons for this. Firstly, the human brain finds it very difficult to locate the source of low frequencies, so it's fairly pointless to pan them anyway. The second reason is linked to the production of vinyl records. If bass frequencies are heavily mismatched in the left and right channels, the needle can potentially bounce right out of the groove, causing skipping.

Indeed, engineers favour the mono representation of bass frequencies for psychoacoustic reasons, as well as for improving frequency distribution for vinyl pressing, and for club playback, as well as other forms of public address. Wave's easy-to-use *Center* is one plug-in that can accomplish this task. On the other hand, Brainworx bx_digital V2 is a commonly used M/S EQ that allows engineers to control the M/S representation of specific frequency bands (Hodgson & Hepworth-Sawyer, forthcoming).

¹⁰² M/S encoding is also discussed in Chapter 2: "DRC and Stereo Imaging."

Audio Example

Audio example 3.2.7 features decorrelated low frequency content (00:00-00:15), followed by the sound of mono low frequency content (250 Hz and below; 00:30), which is noticeably clearer and more refined.

Another common application of M/S EQ is to boost high-frequency spectra between 10-12 kHz in a mix's *side* channels. By highlighting the outer portions of the stereo field, engineers create a greater sense of width in the targeted frequency range.

Audio Example

Audio example 3.2.8 demonstrates M/S EQ. First, listeners hear the track without additional processing (00:00-00:15), and then I apply a high-shelf boost to the *side* channel. The high-shelf boost creates a sense of width, as the boost is only applied to outer areas of the stereo field.

Timbral Colouration: Distortion, Nonlinearity, Enhancement, and Specialized EQs

Although EQ may provide the most direct method for modifying a record's frequency distribution, it is certainly not the only technique that does so. In addition, EQs modify a signal's spectral configuration, but, for the most part, these devices only boost or attenuate frequency information which is already available within the signal. Many hardware devices,

enhancers, and saturators also reconfigure timbre — albeit in less predictable ways than EQ — by applying different types of distortion. This manner of alteration is discussed in the following sections entitled “Analog Colouration and *Warmth*,” “Circuit Components and Non-Linearity,” “Extreme Colouration,” “Exciters, Enhancers, and Maximizers,” and “Adaptive Timbral Modification.”

Any change made to a waveform can be described as distortion. Even applying EQ or compression physically distorts a signal. More commonly within production practice, however, distortion refers to the application of a nonlinear process to a signal, such as tube saturation, or clipping (White 2010). As a matter of fact, many masters benefit from the application of subtle distortion.

More predictable results are typically achieved with adaptive forms of timbral modification, such as dynamic EQ and multiband compression. These two specialized techniques dynamically redistribute spectral energy based on signal input, unlike the traditional equalization methods discussed earlier in this chapter. The following section also discusses these adaptive devices.

Analog Colouration and “Warmth”

The descriptive trait most commonly associated with analog equipment is the signature *warmth* it produces. Although positive descriptors such as *warmth* currently have no standard definition, hobbyists and professionals alike often agree that analog equipment produces a more desirable sound. *Sound on Sound* editor Hugh Robjohns describes a situation engineers encounter (in 2010):

Get a group of recording engineers together, and sooner or later the conversation will turn to a discussion (probably quickly escalating to an argument) about 'analogue warmth' and how things sounded so much better 'BD' (Before Digital) — and even engineers and musicians who've never worked in earnest with all- analogue systems (digital having become mainstream as far back as the 1980s) seem keen to bring this perceived 'warmth' into their productions.

The *warmth* mentioned by Robjohns results from the tendency for analog processors to add *nonlinear* information to a signal.¹⁰³ This nonlinear output is also a form of distortion, yet this distortion is often desirable (Cousins & Hepworth-Sawyer 2013: 125; Robjohns 2010). Specifically, sound engineers call this *harmonic distortion*, a type of distortion that results from the creation of harmonics at integer multiples of the underlying fundamental frequencies.

While digital processing devices often provide a comparatively less *coloured* sound, analog processors produce the opposite. Digital audio devices have never been more prevalent — from cell phones and personal tablets to digital audio workstations — yet mastering engineers continue to use analog devices extensively.¹⁰⁴ Engineer Hugh Robjohns offers the view that nostalgia, as well as the desire for a more *expressive* sonic aesthetic, drives this continued interest in analog equipment (2010):

... in many cases, the technical limitations and imperfections of analogue systems have become an integral part of the quality of the recorded sounds that we all grew up with — and the end result is perceived by many people as being more pleasing than what we can easily achieve today with all- digital recording chains. Further than that, some of the sounds resulting from the 'abuse' of analogue gear have become recognised effects in their own right (tube overdrive and tape saturation being obvious examples).

Interestingly, sound recording isn't the only industry that has found this. Digital cameras and imaging software usually provide a range of 'picture- style image processing' options. My own camera offers Standard, Portrait, Landscape, Neutral, Faithful, Monochrome, and three user- defined modes, for example, each changing the tonal balance, colour saturation, sharpness, and contrast in different ways, to enhance the subject

In short, enjoyment of an artistic product (be it a sound recording, a photograph, a film or whatever) isn't necessarily about precision and accuracy: more often, it's about mood, character and subtle enhancements that make the end result more vivid and interesting than real life.

¹⁰³ In signal processing, when a given device provides an output signal that differs from the input it is described as a nonlinear process.

¹⁰⁴ Please see Katz 2007, Hodgson 2010, Cousins & Hepworth Sawyer 2013, Owsinski 1999, 2008, etc.

As Robjohns suggests, some recordists certainly prize a clean or precise aesthetic, yet many other recordists simply do not. In fact, his characterization provides an insightful glimpse into the artistry of processing sound in a general sense.

While many engineers actively pursue the sound of coveted analog equipment, one can imitate these devices through digital software. Warm-sounding non-linear data can be added through a variety of plug-ins, although it is generally agreed that only a Fairchild compressor, for example, can create the device's sonic nuances. Yet numerous mastering engineers work exclusively *in-the-box* (ITB) with digital tools.

Analog and digital approaches to audio mastering, however, have separate benefits and drawbacks. On the differences between mastering within analog and digital environments, Ray Staff notes that (in Hepworth-Sawyer & Hodgson, forthcoming):

They each have their benefits and uses. No two equalizers or compressors are the same. I never trust anything to be perfect. Everything I will use will have some attributes or flexibility. It will also have its own colouration. Although in-the-box equipment has improved, it's not perfect and there's still things analog can do that we can't do with digital. However, digital plugins will get used more and more. As costs become an issue, more things will be done in-the-box. Sometimes there is just no way in which you can substitute the result you get from going through analog or through a particular analog piece of equipment. You can make that assessment by ear.

Indeed, digital audio mastering is less costly to perform, yet out-of-the-box methods provide desirable results that cannot be fully replicated any other way. Accordingly, most mastering engineers opt to use both approaches.

Circuit Components and Non-Linearity

When using analog hardware, input and output signals differ because transformers, gain stages, and tape (where applicable), each provide a degree of sonic colouration. Transformers work via *magnetic coupling*, whereby a conductive coil is subject to electrical current in order to generate a magnetic field, and then this coil is placed adjacent to another conductor (perhaps another coil). This allows for electricity to be transferred between the coils.

Magnetic coupling always alters the signal such that it expresses a non-linear output (Robjohns 2010). Hence, any signal processing device with a transformer adds nonlinear information to a signal.

Gain stages (or amplifiers) and transformers inject distortion into a signal when raising amplitude levels (see below for an explanation). The character of this distortion, however, can vary widely according to circuit topology. For instance, amplifiers may use a tube (valve) or solid-state design, which are generally known to differ sonically. However, no broad sonic description accurately captures the differences between these circuit designs. While tube circuitry is more commonly associated with *warmth* in a popular sense, some solid state devices also produce a characteristically *warm* sound, such as Neve mixing consoles. These widely celebrated consoles do not feature tube gain stages, yet engineers unanimously agree these devices sound *warm* (Robjohns 2010).

The types of tubes most commonly used within audio processing equipment are triodes (i.e. ECC83/12AX7), beam tetrodes (i.e. KT88/6550), and pentodes (i.e. ECL86) (See fig. 3.2.1-3.2.3). Triodes primarily find application within mic and line-level gain stages such as vocal preamps and guitar preamps. Beam tetrodes and pentodes, on the other hand, tend to find application within power amplifier output stages. Within preamp applications, triode components produce both even and odd ordered harmonics within a signal. On the other hand, beam tetrodes and pentodes, when operating within a power amplifier, are used in class A or class AB *push pull* circuits; and these circuits favour odd-order harmonics (Robjohns 2010).

Figure 3.2.1: Triode Diagram

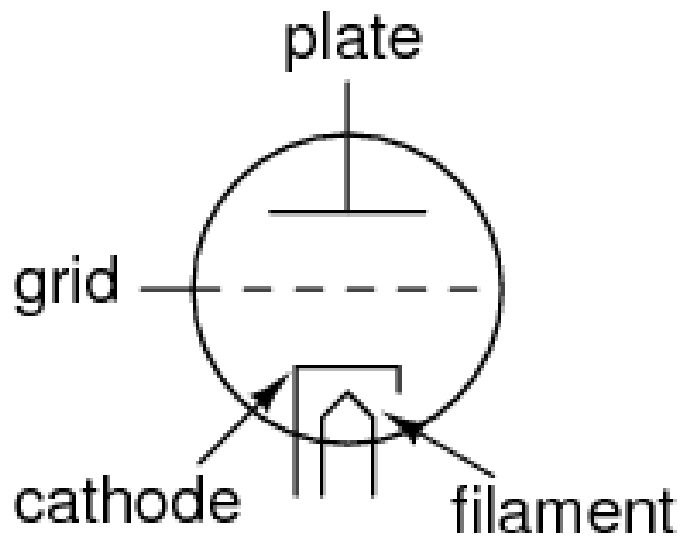
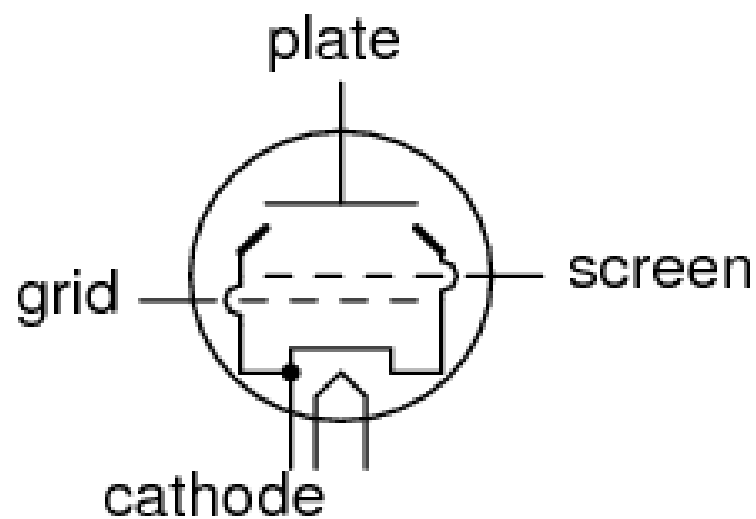

Figure 3.2.1 A triode-style tube. This type of tube is named for its three primary component parts: plate, grid, and filament. Later developments lead to the emergence of the cathode, which emits electrons. ¹⁰⁵

¹⁰⁵ Image reproduced from <http://www.allaboutcircuits.com/textbook/semiconductors/chpt-13/the-triode/>

Figure 3.2.2: Beam Tetrode Diagram



*Figure 3.2.2 A beam tetrode tube. Beam tetrodes feature plates, grids, and cathodes, as do triodes, but they add a screen which performs an electrostatic shielding function between the grid and the plate.*¹⁰⁶

¹⁰⁶ Imaged reproduced from: <http://www.allaboutcircuits.com/textbook/semiconductors/chpt-13/beam-power-tubes/>

Figure 3.2.3: Pentode Diagram

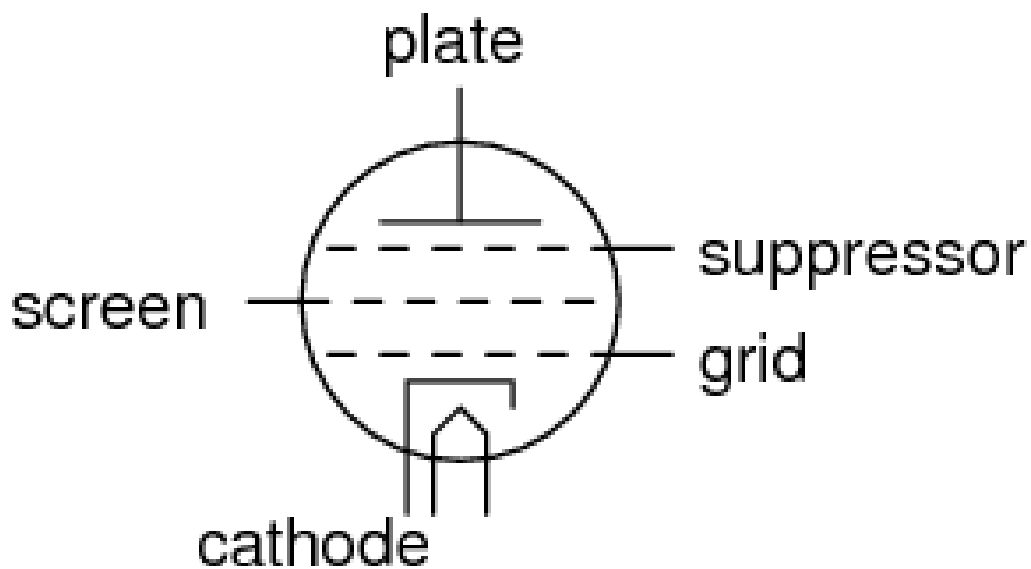

Figure 3.2.3 A pentode tube. In addition to the plate, cathode, screen, and grid, pentode tubes add a suppressor. This component repels extra electrons, which are attracted to the screen, back to tube's plate.¹⁰⁷

¹⁰⁷ Image reproduced from: <http://www.allaboutcircuits.com/textbook/semiconductors/chpt-13/the-pentode/>

Depending on circuit design, solid-state processing hardware may incorporate bipolar, field effect transistor, or integrated circuit designs. As a result of manipulative product marketing, however, the general public associates solid-state equipment with sounds that are *cold, brittle, or sterile*. On the contrary, a number of celebrated *warm*-sounding devices incorporate solid-state components such as SSL and Neve mixing desks.¹⁰⁸

A device's circuit class — typically *A* or *A/B* in recording applications — rather than the presence or absence of tubes, actually determines a device's distortion characteristics (Robjohns 2010). Although the details of electrical engineering minutiae lie outside this study of audio mastering, what remains practically relevant to mastering engineers is how audio processing equipment handles distortion output. In a class *A* device, the amount of distortion present in a signal falls as the signal reduces in volume. As a result, low-level signals feature less distortion than high-level signals. Conversely, because class *A/B* amplifiers provide a more constant level of distortion, the degradation is more audible when the signal level falls.

In addition to circuit design, a processor's tendency to sonically *colour* a signal depends on how it handles an abundance of gain. Most tube devices offer a linear dynamic output over a wide dynamic range, but distortion is produced when a signal exceeds the unit's ability to maintain this linear dynamic relationship (Robjohns 2010). As the device distorts, it begins to add pleasant saturation and harmonically related intermodular artifacts to the signal (Robjohns 2010). The onset of this distortion typically occurs less abruptly than with solid-state circuit components. In fact, solid-state components produce harsher distortion artifacts when exceeding the allowable dynamic range, because these devices use lower voltages (Robjohns 2010). When solid-state equipment begins to clip, harsh intermodulation effects and intense high-level harmonic distortion often occur. Although equipment manufacturers

¹⁰⁸ One equipment manufacturer, Elliott Sound Products, has provided a synopsis of issues regarding typical attitudes surrounding tube (valve) and solid-state components. While this discussion extends far beyond the scope of audio mastering, readers may be interested in an article that discusses common myths. See Rob Elliott, "Valves (Vacuum Tubes) — Myths" at <http://sound.westhost.com/valves/myths.html>.

certainly can address these issues, they seldom do so outside of the most expensive production equipment (Robjohns 2010). For this reason, perhaps, many musicians and hobbyists believe solid state devices must always sound less pleasant than tube devices. However, professional engineers regularly praise solid state equipment, such as *Sound on Sound* editor Hugh Robjohns (2010), who offers:

One such device is a valve, or tube, and most people associate valve amplifiers with the concept of analogue warmth, but it's entirely possible to design solid- state circuitry using discrete transistors or integrated circuits that can sound just as 'warm', if required, and there is plenty of solid- state vintage equipment associated with analogue warmth, not least being classic Neve mixing consoles, for example, without a valve in them. So don't assume that if it doesn't have valves it won't sound good. I have built and repaired valve amplifiers that definitely didn't sound very nice, before or after, and have bought solid- state designs that do, so it's much more complex than just using valves everywhere!

Audio Example

Audio example 3.3.1 demonstrates saturation. First, a track plays without additional saturation (00:00-00:15), then the second segment continues with a light application of saturation (00:15-00:30). After this point, I apply heavy saturation (00:30-00:45). This example is included to help listeners identify the sound of saturation, and it is unlikely that such a strong application would be used during mastering.

In addition to the devices discussed so far, tape machines also cause signal colouration. Differences in tape width, tape formulation, record and replay head design, tape speed, and the type of high-frequency bias applied may add nonlinear data to a signal (Robjohns 2010). Tape machine components — from different magnetic tape heads (i.e., erase, record, and playback), rollers, and reels, to the device's transformer type — introduce changes to a signal's phase and level of harmonic distortion. In addition, transient detail and

dynamic range can also be reduced through tape processes known as *self-erasure* and *saturation compression*. Self-erasure occurs when magnetized particles pass through the record-head on a tape machine. As the tape moves away, the record head's magnetic field is weakened until its strength is comparable to adjacent pieces of magnetized tape. This causes a gap to form between the record-head and the magnetized piece of tape. Newly recorded material — especially quiet, high frequency sounds— are effectively erased when this occurs. In addition, saturation compression occurs on tape when the medium itself effectively runs out of available magnetic particles. This can occur when too much signal level is fed into the tape machine, and the medium essentially runs-out of energy as a result.

Extreme Colouration: Distortion, Saturation, and Clipping

Saturation occurs when analog hardware receives an input level which drives the device into nonlinear operation (Robjohns 2010). Tube and tape saturation, which I discussed earlier in this chapter, provide two examples of this technique in action. Another option, however, for particularly *dull* sounding material is to apply saturation via a digital plugin. Ozone 7, for example, offers a digital tape saturation emulator based on ½” tape decks such as the Studer A810 (iZotope 2015: 1; Figure 3.3.1). The plugin provides users with control over the following parameters: drive, bias, speed, harmonic generation, low emphasis, and high emphasis.

Figure 3.3.1: Tape Saturation Emulator, iZotope Ozone 7



Figure 3.3.1 Ozone's tape saturation emulator. Users can select various tape speeds (15/30 IPS), while also controlling input drive, bias, harmonics, low emphasis, and high emphasis.¹⁰⁹

Input drive determines the amount of saturation applied to the signal, and when this control is turned up, more saturation is present. This provides a gentle, warm distortion which emulates the sound of a real tape machine. A related parameter called *bias* controls the high frequency characteristics of the tape saturation. A negative bias value boosts the high frequency shelf where a positive bias value attenuates this range slightly. Similarly, Ozone emulates the sound of different real-world tape speed settings, as seen on actual tape

¹⁰⁹ Image reproduced from: <http://www.producerspot.com/wp-content/uploads/2015/11/izotope-ozone-7-vintage-tape.jpg>

machines. The 15 IPS setting, for example, provides more “warmth and thickness” to masters, where the 30 IPS setting adds a more subtle “polish” (Izotope 2013: 3). Finally, the harmonic control setting generates additional even-order harmonics which complements the odd-ordered harmonic distribution most characteristically associated with tape technology (Izotope 2013: 4).

In both tape and digital recording systems, when a signal exceeds the maximum allowable voltage, or 0dbFS in a DAW, *clipping* occurs. Signal clipping tends to sound less noticeable in analog systems. As already discussed in this chapter, these devices tend to handle distortion output more smoothly. In digital systems, conversely, clipping tends to sound unnatural, as it provides distortion harmonically unrelated to the input signal (Robjohns 2013).¹¹⁰ This is because when clipping occurs within a digital system, it also causes *aliasing*. In digital recording and playback systems, aliasing occurs whenever harmonic distortion is generated at frequencies above the Nyquist limit (i.e. above 20,050 Hz with a sample rate of 44,100 Hz) (Robjohns 2006).

Despite the tendency for digital clipping to generate harsh-sounding distortion, it is occasionally used as a creative tool when applied in small amounts. While engineers generally agree that the sound of clipping is not desirable most of the time, engineer Phil Tan describes a creative use for this type of distortion (in *Modern Mixing* 2013):

Most people will tell you to just not do it [digitally clip] and that’s fine and I actually don’t disagree with that. But sometimes you can’t really help it, certain parts of songs where there is a whole bunch of things happening all at the same time, everything bottlenecks a little bit. And if you take it down and get it to a point where nothing is clipping then it completely loses the impact. I would rather have something be a little technically incorrect versus something that is technically right but sounds watered down. It’s just a matter of personal preference and if you are okay with it.

¹¹⁰ In audio engineering, non-harmonically related distortion refers to the production of overtones that are not integer multiples of the input source.

While a contentious practice, Tan's account provides a rationale for applying clipping as a creative sonic tool. He also mentions, however, that a number of engineers regularly avoid clipping. *Sound on Sound* editor, Hugh Robjohns, for instance, adopts a strong anti-clipping stance (2013):

As a technical engineer, I'd suggest that clipping is a fault condition that should always be avoided, and that peak control should always be achieved with a fast-acting limiter. However, as a mixing engineer, I know that the harmonic distortion produced through analogue clipping can sometimes be an artistically and musically useful tool in the right context. It produces a very different kind of sound, and at the end of the day, the intended sound is what would determine whether clipping, soft clipping, or limiting is the appropriate form of processing. Personally, I shun digital clipping at all times because I just don't like the resulting sound... but I know of people that do like it.

Exciters, Enhancers, and Maximizers

Equalizers modify a signal's spectral configuration, but, for the most part, these devices only boost or attenuate frequency information which is already available within a signal. If one simply applies a high-shelf boost to a very dull sounding vocal, the end result normally provides excessive *hiss* rather than a brighter sounding voice. In situations such as these, a signal may instead be fed through a variety of exciter, enhancer, or maximizer plugins. These devices, whether software or hardware-based applications, typically combine a number of signal processing techniques for the purpose of adding overtones, or rebalancing a signal's spectral representation through means other than simple filtering. For instance, harmonic synthesis and phase manipulation are two common methods for providing signal enhancement — although, different equipment manufacturers use distinct approaches (White 2010).

The first exciter was discovered during a serendipitous moment. As the story goes, a tube amplifier kit was assembled incorrectly, and consequently featured one working channel paired with one distorted channel (White 2010). The sound of the two channels blended was

much clearer than the original signal alone, however. The resulting device became a prototype for later Aphex Exciters, a device which blends synthesized overtones and harmonic distortion with an existing *clean* signal (Aphex 2001: 10). Later designs incorporate their patented Big Bottom technology, which introduced phase and dynamic alteration capabilities (Aphex 2001: 10). This technology was initially so impactful that the earliest Aphex machines could not be purchased, but were instead rented from Aphex. A royalty fee was paid to Aphex based on the length of the recording on which the device was applied (Aphex 2001:8). No such fee is collected from users of the Aphex Exciter today, who may opt to use a vintage iteration of the device, a current production model, or a software version, such as the emulator Waves currently offers.

Rather than generating additional overtones, BBE's Sonic Maximizer technology temporally redistributes a signal's harmonic components (Figure 3.3.2). In fact, this unit employs a series of active and passive filters which apply different delays across low, middle, and high frequencies. The unit introduces delays of 2.5ms to low frequencies (below 150 Hz) and 0.5ms to middle frequencies (150 Hz-1,200 Hz). Frequencies above 1,200 Hz are not subject to delay, because a compressor/expander processes this spectral region. The device can also cut frequencies below 200 Hz by as much as 12 dB, or boost them by 10 dB (White 2010). The BBE Sonic Maximizer manual outlines the following reasons for applying this processing strategy (2016: 3):

Research shows that the information which the listener translates into the recognizable characteristics of a live performance are intimately tied into complex time and amplitude relationships between the fundamental and harmonic components of a given musical note or sound. These relationships define a sound's "sound".

When these complex relationships pass through a speaker, the proper order is lost. The higher frequencies are delayed. A lower frequency may reach the listener's ear first or perhaps simultaneously with that of a higher frequency. In some cases, the fundamental components may be so time shifted that they reach the listener's ear ahead of some or all of the harmonic components.

This change in the phase and amplitude relationship on the harmonic and fundamental frequencies is technically called "envelope distortion." The listener perceives this loss of sound integrity in the reproduced sound as "muddy" and "smeared." In the extreme, it can become difficult to tell the difference between musical instruments, for example, an oboe and a clarinet.

BBE Sound, Inc. conducted extensive studies of numerous speaker systems over a ten year period. With this knowledge, it became possible to identify the characteristics of an ideal speaker and to distill the corrections necessary to return the fundamental and harmonic frequency structures to their correct order. While there are differences among various speaker designs in the magnitude of their correction, the overall pattern of correction needed is remarkably consistent.

As mentioned by BBE, the Sonic Maximizer reverses the causes for envelope distortion in loudspeakers. The device applies delays to ensure that low and mid frequencies reach the listener's ears after high frequencies, and in doing this the unit replicates the spectral projection of natural sounds. As the developers of the Sonic Maximizer state, many loudspeakers reverse the natural temporal projection of frequency information such that high frequencies reach the listener *after* low and middle frequencies. Thus, this device proves useful for refining a track's timbre without directly applying EQ.

Figure 3.3.2: BBE Sonic Maximizer (Rackmount)



Figure 3.3.2 illustrates the control interface for the BBE Sonic Maximizer. The device provides two simple controls: lo contour, and process.

Adaptive Timbral Modification: Multiband Compression and Dynamic EQ

Multiband compression has been discussed more thoroughly in the chapter on *Dynamics*, yet this technique also drastically modifies timbre. According to Mark Cousins and Russ Hepworth-Sawyer, “a multiband compressor can change the timbre of a recording as much as, if not more than, an equalizer” (2013: 128). Thus, the multiband compressor provides engineers with one of their most powerful tools for timbral modification.

When mastering a record, a multiband compressor can be used to correct spectral deficiencies. Users can compress a specified frequency target, and then add make-up gain, to raise the average amplitude of the affected spectra. If a track’s bass instrumentation sounds deficient, a mastering engineer might program the multiband compressor to compress sub-

bass frequencies between 20-60 Hz, while simultaneously boosting frequencies between 200-300 Hz via the application of make-up gain in this region.¹¹¹

Mix engineer David Wrench (FKA Twigs, Caribou, Jungle) discusses some common approaches for controlling spectrum via multiband compression. He states (in Hepworth-Sawyer & Hodgson, forthcoming):

I'm a big fan of multiband compression, I think it's a really really useful tool. I use it on bass instruments because often when you're compressing, what you want to actually be controlling are certain frequencies. So by just selecting a certain band, you can allow the top end of the bass come through as it wishes, while simultaneously attenuating the low-mids, for example. With vocals, sometimes you think you should be EQing, but all you want to be doing is controlling the harshness that comes through on certain loud sections. So, in those cases it makes sense to be using the multiband compression at the top end, maybe around sort of high-mids, just to control it when it gets peaky (**Q: or maybe for certain cavities of someone's voice?**). Yeah exactly. If you just hear something that's peaking, instead of EQing that frequency out for the whole track, [I'd rather] just control it when it builds up too much. I nearly always use multiband across the mix, in fact something I often do across the mix is I'll have an EQ, and a compressor, then a multiband and limiter, and actually, that's how I master my mixes for previewing.

As Wrench describes, he uses this tool to modify the timbre of individual instruments and the stereo bus. Whether reducing *harshness* around the high mids, or boosting the bass (without also increasing the low-mids), the multiband compressor allows engineers to perform in-depth timbral reconfiguration. Rather than simply removing harsh frequencies through filtering, a multiband compressor provides an adaptive solution, in which problematic spectral zones are momentarily attenuated as a user-specified threshold is breached. For instance, an EQ dip at 5 kHz may reduce some of a track's harshness, but at the same time, this strategy may lessen a track's overall *bite*. To avoid this situation, engineers

¹¹¹ As discussed in Chapter 2, all compressors can raise the average amplitude of a signal. To accomplish this with multiband compression, engineers first attenuate the peaks of a specified spectral region with the device. After compressing the signal, make-up gain is applied to raise the average level of these compressed frequency regions.

may use multiband compression to briefly compress spectral energy around 5 kHz, but only when it occurs in abundance.

Another tool which provides adaptive control over a record's timbral qualities is the dynamic EQ. Unlike traditional EQ, where spectral boosts and cuts are applied continuously for the duration of a track, dynamic EQ can selectively boost or attenuate a specified frequency each time a threshold is crossed. Dynamic EQ is often used to attenuate undesirable frequency content, yet it also provides a novel method for boosting a designated spectral region. Of course, mastering engineers cut frequencies far more often than they boost them; however, when frequency boosting is required, dynamic EQ provides a more transparent method. If a hip hop track exhibits weak-sounding low frequency content between 100-200 Hz, a mastering engineer might apply a dynamic EQ that boosts this region when such low-end energy is present (Shelvock 2017: 177). This approach typically provides a frequency boost that reinforces the track's arrangement characteristics. Every time the music's low frequency instrumentation (i.e., bass guitar, kick drum, bass synthesizer) occurs, the dynamic EQ instantaneously boosts the signal, but otherwise remains disengaged.

With a dynamic EQ, cuts (or boosts) are applied in accordance with a user-specified threshold value. For example, engineers often target harsh frequencies between 2 and 7 kHz with this device, because many project-studio monitors poorly recreate upper-middle frequencies (Cousins & Hepworth-Sawyer 2013: 107). Thus, much of a mastering engineer's clientele may deliver pre-masters featuring superfluous high-middle frequency information. If a basic EQ filters these frequencies, however, one risks removing essential timbral components along with any deficiencies that may also be present. With dynamic EQ, as with multiband compression, spectral filtration is applied using a threshold to determine *when* processing is applied. As a result, when a specified frequency band features excessive energy, a dynamic EQ can simply attenuate this region according to its signal strength. If one targets

the region around 5-7 kHz and designates a 6 dB threshold, every time spectral energy in this region exceeds -6 dB, the dynamic EQ attenuates these frequencies. Perhaps the most useful feature of this device is its ability to *dynamically* alter the amount of gain boosted or attenuated. Thus, attenuation (or boosting) is applied based on input amplitude, such that dynamic EQs simply increase the amount of filtration as more energy is present.

Audio Example

Audio example 3.3.2 demonstrates dynamic EQ. I have programmed the dynamic EQ in this example to attenuate excess sub-bass energy when it occurs. In this track, an abundance of sub-bass energy is present each time the kick drum sounds (00:00-00:15), and dynamic EQ is applied (00:15-00:30) to tame excessive sub-bass frequency content in the signal

Example 3.3.2 illustrates a method for attenuating frequencies with a dynamic EQ, but this device can also provide a novel approach to boosting selected frequencies. On a dull-sounding track, one can use the dynamic EQ to foreground high-mid or high frequency content. However, in order to avoid producing an overly harsh or *biting* sound, engineers can program the dynamic EQ to provide momentary high frequency boosts only as the threshold is exceeded.

In addition, some dynamic EQs provide the capability to work in *inverse* mode. In the above example, boosts and cuts are applied once a given threshold is crossed, but *inverse* operation causes boosts or cuts to occur when the audio's amplitude does not exceed the specified threshold (Brainworx 2011: 10). This technique can be useful for removing low level noises, or for boosting a weak frequency region.

Perhaps the most commonly used form of dynamic equalization is the process known as *de-essing*. This technique is so named because it targets high frequencies associated with *s*-sounds. In fact, de-essers find application within numerous professional mastering rigs, and mastering engineers Nick Watson (Fluid Mastering), Kevin Gray (Cohearant) and Bob Katz (Gateway Sound) all make use of the Weiss DS-1 de-esser (Hepworth-Sawyer & Hodgson, forthcoming). Mastering engineer/researchers Jay Hodgson and Russ Hepworth-Sawyer delineate various uses for the de-esser during audio mastering (Hepworth-Sawyer & Hodgson, forthcoming):

When the offending frequency is somewhere in the midrange of human hearing (ie., 1 kHz - 7 kHz), as they tend to be, mastering engineers will often reach for a dedicated De-Esser of some sort. Focusing the De-Esser detection circuitry onto the problem region, engineers then set its threshold so only the offending spikes trigger it to action, and then they adjust the remaining dials and knobs to musical taste. Ideally, only excessive frequencies are thus attenuated.

De-Essers are usually only required when mix engineers have failed to dock a particular instrument as well as they could. Indeed, spectral disbalances usually manifest less abstractly than the concept of a “spectral contour” might suggest. Engineers don’t typically hear an excess at, say, 2 kHz so much as they hear problematic tones in a mix: i.e, overly “picky” guitars or basses; “clicky” kick drums with too much attack; snare drums with too much “snap”; harsh “ice pick” hihats; overly sibilant vocals; “trashy” too bright cymbals; and so on.

De-essers provide adaptable control over numerous timbral components, including overly loud guitar and drum transients, harsh cymbals and hihats, and similar harsh sounds with prominent high-mids. This ability to instantaneously attenuate (or boost) a specified frequency range based on input amplitude allows mastering engineers to modify a record’s timbral representation without completely reconfiguring its sonic design — although such an invasive approach is required occasionally.

Audio example 3.3.3 applies a de-esser to a track in order to tame harsh sounds between 5 and 6 kHz. At first (00:00-00:15), an abundance of fatiguing high frequencies are audible. De-essing occurs 15 seconds into the track (00:15-00:30) in order to combat this harsh sound.

In addition to the applications discussed above, dynamic EQs are also useful for conditioning signals before they are sent to outboard processing equipment. Engineers often find that adaptively reducing high-mid and bass spectra can cause outboard processors to behave more favourably. Michael Rodgers describes such a method for *tidying up* a signal (in Hepworth-Sawyer & Hodgson, forthcoming):

...I get a lot of mixes, for whatever reason, where the 2k-5k area is just really over the top. What I can do is employ a dynamic EQ if something is spiking in that area. It could be a vocal, perhaps some sibilance. Sometimes sibilance is not always above 7k, it's around 3k — a really sharp midrange thing — and I'll tame that before I get into any compression. I don't want anything triggering my compressors in a way it's going to effect the attack and release envelope, especially the attack side of the compressor. That goes just as much, if not *more so*, in the low-mid and sub-region of the mix. There might be an 808 kick drum that's being used as a bass. Let's say one of those notes is louder than the rest, I'll go in there, duck it maybe with a dynamic EQ, or a plain old static parametric EQ, and get everything in shape.

I try to control that stuff as much as possible without compression. I might use a dynamic EQ in one area. I really don't want to strap on a compressor, squeeze it and then go from there. I find that at that point I'm most likely going to end up with something a little two dimensional. There are also times where there's nothing you can do. You call it a day and have lunch. The fact of the matter is that for my workflow, and this may also be because of my mix engineering background, I really almost try and go in there and say, "I know you don't want that vocal sitting like that." I may work on that particular area prior to feeding the music into my analog rig. I do this corrective work digitally, then send it out to my analog system and go from there. I'll do boosts, or attenuate. At this point I'm trying to make the record sound like a record to me based on what I've been listening to in that genre. This is where the rubber meets the road on the EQ side of things. (Hepworth-Sawyer & Hodgson: forthcoming)

Rogers identifies a common application for dynamic EQ: to tame a signal's undesirable characteristics before sending it through a hardware signal chain. Indeed, as he notes, it is necessary to restrain some radical elements within a signal, such as, overly harsh transients and overbearing bass spectra, before sending it through various outboard circuits. This ensures sensitive hardware equipment does not emphasize these deficiencies.

Interpreting and Modifying Timbre: The Role of Phenomenology in Timbral Design

In the previous section, I discussed numerous types of timbral modification devices such as EQs and enhancers. In this section, I examine how these devices are actually used by engineers. To do so, I focus on the *experience* of mastering engineers as they operate EQs and related devices. While no standard prescription instructs engineers how to operate timbral modification equipment, some general guidelines are found in books and interviews.¹¹²

Available guidelines for modifying timbre during audio mastering arise from a combination of the following nebulous social and material circumstances: (i) the physical constraints of human listening faculties, (ii) the material limitations of audio reproduction technology, and (iii) specific generic expectations involving music type, media type, and historical context. Thus, the following sections discuss how mastering engineers negotiate these constraints when finalizing a record's timbre.

Mastering engineers may receive records that exhibit any number of spectral deficiencies, or perhaps none at all. Timbral alterations made during mastering can be categorized into two broad types: strategies for enhancement and strategies for correction. Both types of timbral manipulation require the adoption of numerous phenomenological strategies for sonic evaluation (which were covered in more detail in Chapter 1). As timbre is

¹¹² In addition, mastering sessions I attended at Jedi Mastering/MOTTOsound over the last several years inform this section's content.

altered, these changes are also auditioned in real time, and this continues until the mastering engineer *signs off* on a record as a completed product. However, no standardized method tells engineers how to apply boosts and cuts. Instead, mastering engineers finalize timbre on a case-by-case basis to establish a suitable sonic profile for whatever record they happen to be working on. And, at the same time, mastering engineers also consider general sonic trends within the record's genre.

When applying corrective EQ, mastering engineers reduce (or boost) frequency energy according to the perceived aesthetic requirements of the project. For instance, 10-60Hz is notoriously difficult to control, and engineers must often correct imbalances in this region. Different genres, however, maintain drastically different spectral profiles, and thus require separate approaches for addressing this subsonic region (Cousins & Hepworth-Sawyer, 2013: 102-3). For example, recently released (e.g., 2017) trap and hip hop records tend to feature more prominent sub-bass frequency information than indie rock or indie folk tracks.

Genre-based trends in frequency distribution can be observed via spectral analysis. Below I have chosen 6 examples of popular hits to analyze from two separate genres: trap and indie pop music. The trap tunes are “Kung Fu” by Bauuer (2016; Fig. 3.7.1), “Gatorade” by Yung Lean (2013, Fig. 3.7.2), and “Bussin’ Jugs” by Gucci Mane (2012, Fig. 3.7.3); whereas the indie-pop tunes selected are “Reflektor” by Arcade Fire (2013, Fig. 3.7.4), “Somebody that I used to Know” by Gotye (2011, Fig. 3.7.5), and “Ho Hey” by the Lumineers (2012, Fig. 3.7.6). The spectral analyses below were acquired via iZotope's *Insight* software from the Ozone 6 suite. Each figure is a spectrogram which averages spectral transformations over time. The trap examples in figures 3.4.1-3.4.3 demonstrate an abundance of low-frequency energy below 100 Hz. Each indie-pop selection, on the other hand (Fig. 3.4.3-3.4.7), favours the spectral regions above 100 Hz, particularly between 200

and 300 Hz. As a result of these spectral tendencies, mastering engineers must remain keenly aware of such subtle generic variations in timbral design when applying corrective EQ to a record's low-frequency distribution.

Figure 3.4.1: “Kung Fu” by Bauuer (2016)

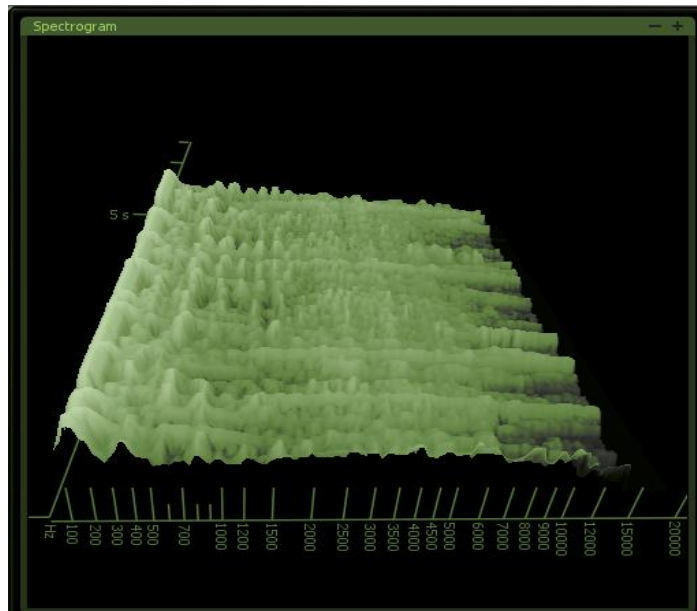

Figures 3.4.1-3.4.3 provide a spectrum analysis of a typical trap tune. Notice the excess of bass energy compared to the indie examples below

Figure 3.4.2: “Gatorade” by Yung Lean (2013)

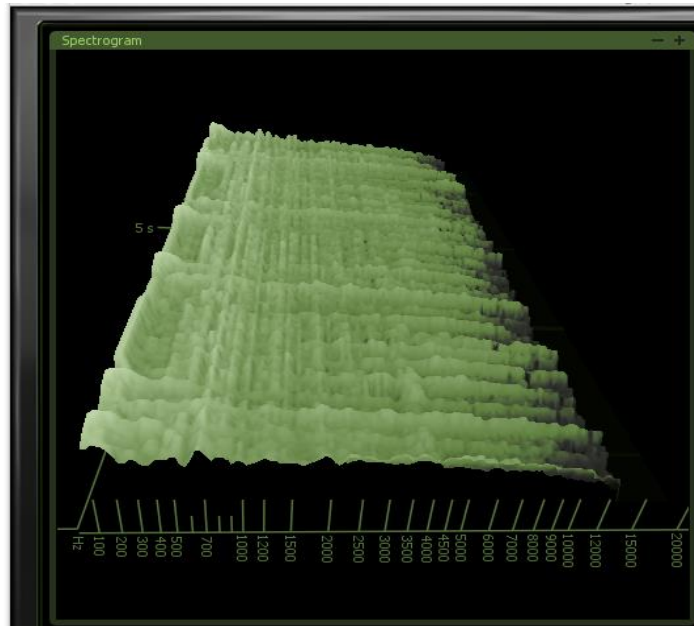

Figure 3.4.3: “Bussin’ Jugs” by Gucci Mane (2012)

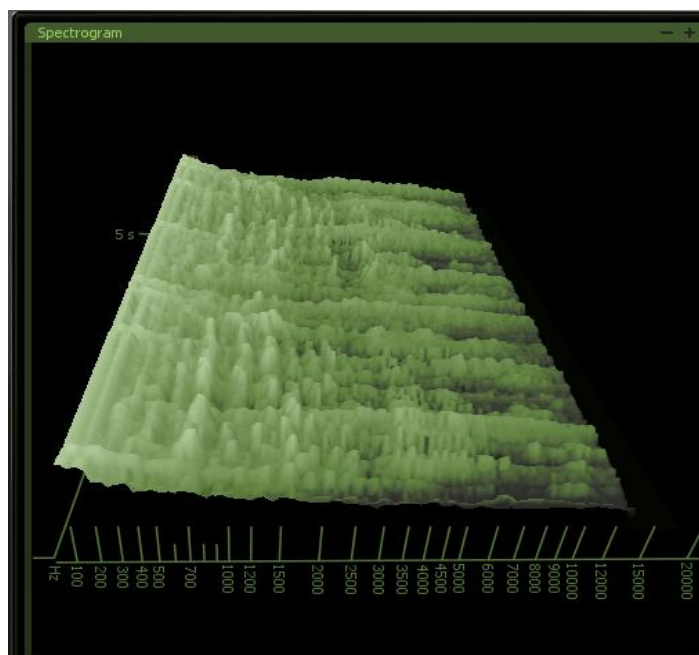
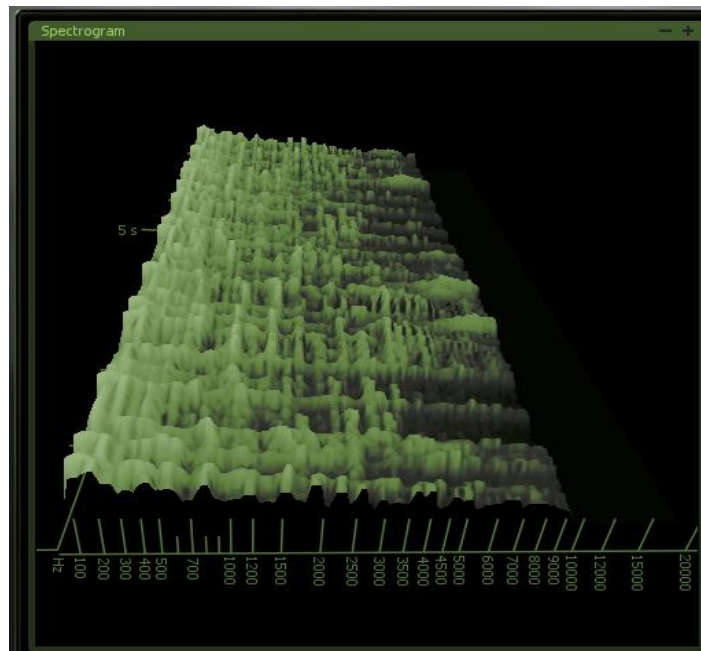

Figure 3.4.4: “Reflektor” by the Arcade Fire



Figures 3.4.4-3.4.6 provide a spectrum analysis of a typical indie tune. Notice how this track demonstrates less energy in the sub-bass region than the trap examples.

Figure 3.4.5: “Somebody That I Used to Know” by Gotye (2011)

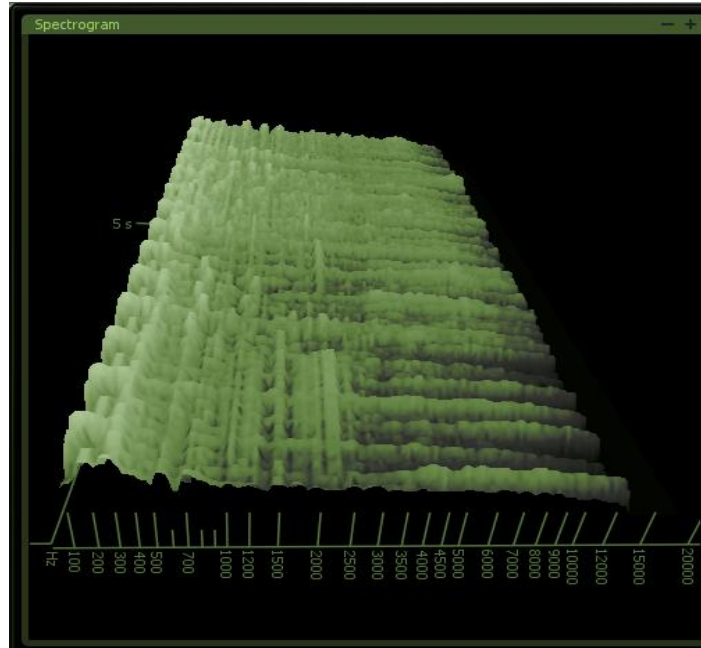
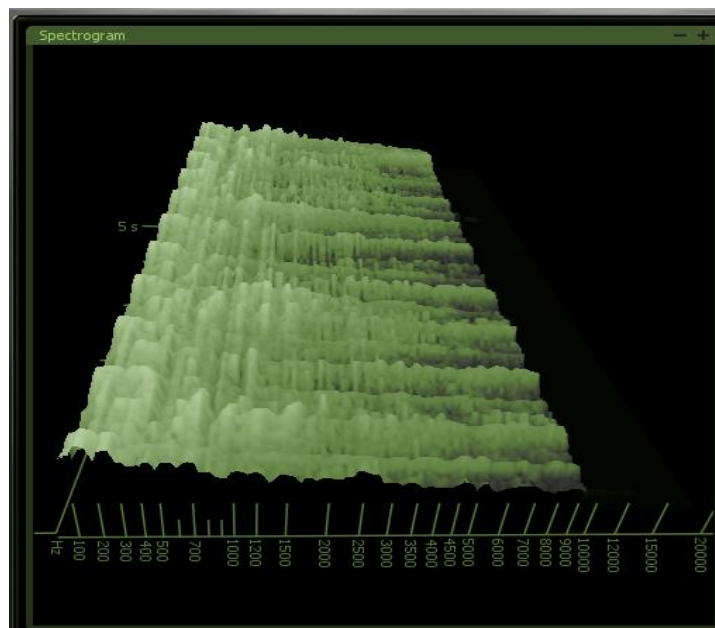

Figure 3.4.6 :“Ho Hey” by The Lumineers (2012)



The majority of professional mastering engineers work on many musical genres, and this requires a high degree of flexibility on their part. For instance, Nick Watson of Fluid Mastering — who works on material as diverse as Deep Purple, Coldplay, and Fleetwood Mac — shares the following insights regarding his phenomenological approach to applying EQ (in Hepworth-Sawyer & Hodgson, forthcoming):

It's one of those things that is quite hard to put into words. I often start off with an awareness of things that are bugging me sonically. I guess that's step one. I try to discern if there are certain resonances in the room where it was recorded, for example, or perhaps certain areas where there was too much energy at a certain frequency range. To me these issues create an annoyance while I'm listening. It's something that just keeps popping up and bugging me. Issues like that would probably be the first thing that I would actually attempt to address. I would probably use a notch digital EQ or a dynamic EQ or something like that. This *tucks things in*, so to speak, before I can then start looking at what can be enhanced. If there's a bad resonance that's really sticking out in a certain range, it can then mask other important parts of the spectrum. If you can clean up these areas, however, all of a sudden, you can access other frequency ranges more freely, and perhaps add some definition here and there. That's a very common approach for me: I look for things to notch out digitally and then when I want to enhance the things around that range I'm more likely to use an analog EQ to lift them up again.

To begin the mastering process, Watson hones in on certain *annoyances*, which detract from the listening experience. For the most part, he explains that these problems manifest themselves on records as poorly balanced spectral energy. After correcting these issues, he begins *enhancing* a signal, and this becomes a far more manageable task if errors have already been removed.

Mix engineers, and other recordists, routinely expect mastering engineers to provide this finalizing perspective on their work. The experiential approach Watson describes above is a foundational component of audio mastering, because the final version of any audio master, of course, reproduces a singular psychoacoustic perspective on a given mix or project (Hodgson 2014: 36). Hence, recordists tend to build close relationships with mastering engineers, and they hold the opinions of trusted mastering personnel in high regard. Mix

engineer and producer Alex Krotz (Barenaked Ladies, Billy Talent, Die Mannequin, Three Days Grace, Matthew Good) describes his working relationship with mastering personnel as follows (in Hepworth-Sawyer & Hodgson, forthcoming):

I'm open to different things. If a mastering engineer hears it, I like to let them do their job and I ask, "What do you think this track needs?" I know what I *thought* it needed in the mix, and I like the way it is, but if you think there's something that can help it — great. I think, "You've seen a lot of different music styles as well so let's see what you got." Sometimes [a given] approach works, and other times I simply don't like what it did to my mix. I'm open to that because I know it's another part of the creative process.

Indeed, as demonstrated in Krotz's account, professional mix engineers often claim their work benefits from the subjective input of another audio professional (Cousins & Hepworth-Sawyer 2013: 39).

One such technique that demonstrates this type of subjective input is known as *notching*. In order to create a notch filter, engineers typically program an equalizer (such as a parametric EQ) to focus on a narrow collection of frequencies. As mentioned throughout this chapter, engineers hone in on a problematic spectral region and then use the filter to audition it reacting to different spectral regions. To find these problematic frequency areas, engineers rely on a phenomenological approach where a narrow-Q filter is auditioned across the troublesome zone. Bryan Martin (in Hepworth-Sawyer & Hodgson, forthcoming) describes the typical process for *sweeping* through poorly balanced spectral regions as follows:

One thing that happens is the overuse of compression these days, as well as the possibility of a *build-up* from bad plugins. As a result, you end up with non-harmonic crap or added frequencies that are not really in the music. Or perhaps the result is that very quiet harmonics are boosted until they are at parity with the regular harmonic content. So what generally happens is: you have a buildup of low frequency sludge below around 40 Hz and you can often have a lot of noise generated above 10K, which is also non-harmonic. Hence, to deal with this issue you typically create a very narrow notch filter and sweep through the frequency spectrum. Interestingly, you sometimes don't really hear either of these artifacts very well until you get rid of them. So if you add, for example, a narrow notch filter drop of 6 dB, you just start however low you can — perhaps 20 Hz — and start sliding it up slowly. A lot of

times you can't even hear at this low frequency level because your speakers aren't outputting frequencies this low. As soon as you hit the problem spot, however, all of a sudden your bottom end will pop out and become very clear. The same process can be repeated in the high-end. If you create a notch, start at 20 kHz and slide it down you will hit that noise spot and all of sudden you'll feel less pressure on you as find the offending noise. So both of those work quite often, everything else is specific, but those two problems occur almost every time.

As Bryan Martin has described, he auditions a narrow filter acting upon various frequency bands, before he attenuates the perceived problematic zones. Thus, this phenomenological corrective approach enshrines his aural perspective onto the record, and each time the record is played back we hear Martin's sonic point of view.¹¹³ These aesthetic judgements are highly personalized, of course, and no two mastering engineers will supply a client with an identical sonic treatment of a recording.

In the same way that a phenomenological approach informs timbral assessment, enhancement, and correction, so too does this experiential method inform equipment selection. For instance, engineer Nick Watson details his trusted rig for applying corrective EQ as follows (in Hepworth-Sawyer & Hodgson, forthcoming):

When it comes to notching I use the 5600, the TCX 6000 and I've got the Massenburg EQ algorithm on there. That's what I usually use for notching down problem frequencies. Occasionally there might be something that I'll be doing in mid-side, in which case I'll use one of the other engines in its place for that.

Here, Watson mentions a few standard tools he often uses for corrective equalization.

Regarding sonic enhancement, on the other hand, he employs other tools (in Hepworth-Sawyer & Hodgson, forthcoming):

When it comes to more analogue side of shaping and sound colouration, it's mainly the Manley Massive Passive or Prism MEA2. I bounce between them depending on what the range is. Probably everybody says the same thing. The MEA2 is really nice and transparent and it's nice for rounding out the top. It can also add a little bit of bass

¹¹³ I use "point of view" here to denote one's subjective perspective rather than the visual sense (which has nothing to do with hearing).

at times. The Manley is more colourful and a bit less predictable, and that can be valuable sometimes as well.

Clearly, then, engineers such as Watson use several different EQs for various purposes. Indeed, when correcting or enhancing a signal, a variety of tools may be used, and the decision of which to choose depends wholly on the subjective perspective of the mastering engineer.¹¹⁴ Furthermore, specific *best practice* prescriptions for equalizer settings cannot be made for the same reason: every record requires a different processing strategy. However, professional engineers provide some general processing guidelines in trade publications and published interviews. One such recommendation comes from Bob Ludwig, the first mastering engineer to receive an album credit. He discusses *how* to use an EQ during mastering in a general sense (in Hodgson & Hepworth-Sawyer, forthcoming):

It is a matter of context. Mix engineers will often really crank on an equalizer to get it where they want. A boost of 10dB (FS) or more is not a rare mix practice. Mastering is the opposite as it totally deals with minutiae. Any particular frequency boosted or dipped 3dB would be considered an extreme level of colouration in mastering. I think many mix engineers have struggled so much to get the mix to where they are happy, and for them to look at it again under a microscope is simply too difficult. By that point they are lacking perspective. Mastering is dealing with the trees in the forest of the mix.

Thus, as Bob Ludwig explains, one typically tries to avoid dramatic boosts and cuts when applying equalization during mastering. This strategy remains the normative approach mastering engineers employ, because large EQ boosts and cuts tend to add undesired *colour* and other sonic *artifacts* which can drastically alter a signal.

¹¹⁴ A complicated exception to this statement exists in the form of automatic mastering services such as LANDR. In one sense, LANDR relies on computer algorithms to master recordings and thus could be understood as a non-phenomenological event. Brand ambassadors from LANDR, however, would argue that their algorithms simply *borrow* the subjective perspectives enshrined within previously recorded music. Indeed, LANDR operates via mastering algorithms accumulated through contemporary big data extraction methods, and certainly provides a quasi-intelligent output. At the time of writing, however, both LANDR spokespeople and recording personnel do not see LANDR as a replacement for mastering engineers, as the service cannot yet provide an output that is both fully adaptive and of sufficient quality for playback.

Although a more coloured sonic character is occasionally a cherished feature of popular records, mastering engineers use discretion when reconfiguring the spectral design other recording personnel have established. Otherwise, one risks upsetting collaborators such as the artist, tracking engineers, mix engineers, and the producer. This is because such an approach effectively *undoes* the work of previous engineers. In addition, equalization boosts and cuts that occur during mastering apply to the entire record, such that if one boosts 500 Hz, then all sonic components around this frequency area will sound more prominent. For example, if a mastering engineer receives a record featuring a weak sounding snare drum, with little energy around the low-mids, the solution probably does not involve boosting 300-500 Hz with an EQ. This boost would also cause the harmonics and fundamental frequencies of all sonic events around 500 Hz to stand out, and in-so-doing one risks causing a record to sound *boxy* (Katz 2007: 47).¹¹⁵ Moreover, as mentioned earlier in this chapter, mastering engineers tend to avoid applying boosts with traditional EQs. If a given project did indeed require a boost around 500 Hz, a mastering engineer might apply a 1-3 dB (FS) boost to this region, when adhering to Ludwig's recommendations.

Indeed, mastering engineers often decry extreme EQ boosts as unnecessary, or distracting. Some engineers, such as JP Braddock, advocate that all engineers (even mix engineers) overuse EQ as a crutch (in Hepworth-Sawyer & Hodgson, forthcoming):

[I disagree with] the overuse of EQ within mixing: why we are even EQing the signal while we are tracking? Move the microphone, change it in space to get the actual tonal outcome you want. You don't have to apply anything to it. This principle carries over to the creation of computer-based sound as well, such as synthesis.

In other words, Braddock believes the timbre of all recorded sounds, whether synthesized or acoustic, should be thoroughly evaluated before mixing and mastering occur. Ideally, recording engineers ensure that performances exhibit sufficient quality levels while tracking,

¹¹⁵ *Boxy* is a term used to describe an abundance of frequency information around 500Hz (Katz 2007:47).

but sonic expectations may change as a project nears completion. Records often proceed through several dedicated mix phases, each of which audition different sonic configurations of the same song or project, and mastering engineers are called upon to collate these disparate timbral perspectives.

Although tracking, mixing, and mastering engineers over-apply EQ at times, some recordings require engineers to provide radical timbral boosts and cuts. In these situations, engineers use a technique known as *feathering* for a more subtle result (Owsinski 2008: 42). Feathering involves boosting or cutting neighbouring frequencies around a deficient spectral region in order to make the processing sound less obvious (Massenburg 1972: 6). Instead of applying a 5 dB boost at 100 Hz, for instance, one could instead *feather* this area. To achieve this, engineers might apply a 3dB boost at 100 Hz, while simultaneously incorporating a 1 dB boost at both 80Hz and 120Hz (Hodgson & Hepworth-Sawyer, forthcoming).

In addition to feathering, mastering engineers use notch filtering when dramatic equalization is required. Notching was discussed above as a technique for narrowly attenuating a problematic frequency band; however, this technique is also used where larger timbral problems occur. Typically, engineers use a parametric equalizer with an adjustable Q value to hone in on a troublesome area. They either define a small spectral zone (or Q value), or perhaps only a few frequency bands. At this point extensive attenuation is applied to tame the deficient area, but the area may also require notch filters in harmonically related zones, such as the problematic sound's 2nd, 3rd, and 4th harmonics (Hepworth-Sawyer & Hodgson, forthcoming).

Chapter Four

A Case Study in Audio Mastering

This case study takes readers through the mastering process for a record I created called *Summoner* (2017), an EP which is available on both iTunes and Spotify.¹¹⁶ Many artists now engage in a process whereby they master their own records, and this is increasingly common in genres such as hip hop and EDM. Below I provide a musical context for the audio mastering techniques I discuss in Chapters 1-3. However, in order to master this record, I did not deploy every technique discussed in the dissertation. In fact, to do so would not accurately represent the process of mastering audio. For example, mastering engineers rarely apply broadband EQ boosts, multiband compression, dynamic EQ, and M/S EQ simultaneously. Instead, they optimize records using only the tools and techniques required for a given project.¹¹⁷

In order to show how mastering engineers evaluate and finalize records, this case study is divided into five sections. I first describe my assessment of the record upon hearing it for the first time in a mastering environment. In general, initial evaluations such as these determine how an engineer ultimately treats a client's record. Given the importance of sonic evaluation to the art of audio mastering, I discuss details regarding my early phenomenological assessments of the final mixes for *Summoner* (2017). After this occurs, I provide readers with details concerning the audio mastering operations outlined in chapter 1. These operations include capturing the record within a DAW, applying signal processing

¹¹⁶ This demonstration was approved by myself, “kingmob,” and the co-founders of the record label *ghosttape*.

¹¹⁷ The evaluation criteria mastering engineers use to determine how to optimize a record are covered in Chapter 1.

techniques, sequencing the record, and formatting the material for the appropriate platform(s).

Initial Assessment

Summoner (2017) contains five tracks: “Summoner,” “falling away from...,” “Mobbin’,” “Villainous,” and “Be the Colour.” Generally speaking, these tracks conform to the experimental hip hop genre, but no vocalist raps on the record.

In terms of arrangement, the record features prominent drums and bass instruments, as well as heavily saturated recorded material and vinyl samples. Reversed and *chopped-up* vocal samples, synthesized instruments, strings, drum samples, and 808 subbasses account for the majority of the record’s arrangement.¹¹⁸ In addition, as heard in EDM genres, such as progressive house and trap, many of these songs feature impacts, risers, splashes, and other similar effects. Some comparable artists include Knxwledge, 20syl, Swum, Statik Selektah, Yung Gud, and Mad Lib. Key sonic features of records from this genre include an almost *lo-fi* sounding midrange at times, and extensive saturation. In addition, artists in this niche often favour the sound of heavy compression in both mixes and masters.

Most tracks on *Summoner* (2017) peak around -1.5 to -2dB(FS), except for “Summoner” which was much quieter (-5dB). The track “Be the Colour,” was noticeably louder than the other tracks when I imported them, and I confirmed this assessment using the Pleazurize Music Foundation’s *offline* DR meter.¹¹⁹ As Figure 4.1.1 illustrates, “Be the

¹¹⁸ *Chopped-up* refers to edited vocals, wherein the editing process creates new melodies and sonic textures. The *808* refers to a popular style of sampler that uses a low frequency sine wave as a bass instrument.

¹¹⁹ *DR* refers to dynamic range, which compares a signal’s peak levels and RMS. For more information, please see Chapter 2. Ian Shepherd explains that DR meters remain highly relevant despite the availability of other tools (2013): “Is it time to stop using DR values? Maybe the goals of *Dynamic Range Day* and its *Challenge* should be updated to request a minimum ‘loudness range’, LUFS reading or some other metric? I don’t think so. Not all albums will have (or need) a wide ‘loudness range’ – we’re not trying to stop people making dense, intense music, or creating heavily

Colour” features a DR of 13, whereas “Summoner” has a DR of 14 (Figure 4.1.2). These two illustrations provide visual evidence for my aural evaluations of the record’s loudness characteristics.

Figure 4.1.1

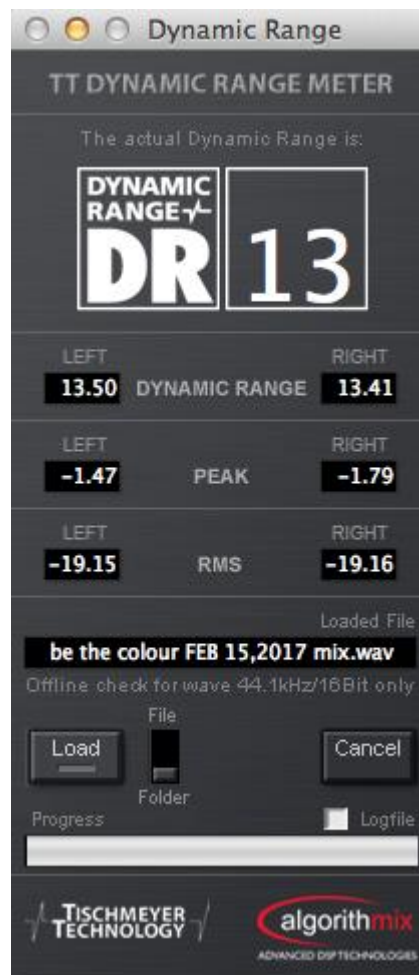

distorted textures. We just want people to realise they don’t have to make their music sound like that in order to ‘compete’. As ITU volume normalisation becomes common-place, we’ll be more free than ever to mix and master our music to sound exactly as we like it, and know that people will hear it the way we intended. As I said above, DR values are quick, convenient and familiar.”

Figure 4.1.1 provides a screenshot of Pleazurize Music’s offline TT_Meter. This software provides information regarding a track’s RMS, DR, and Peak levels. For this illustration, I chose the record’s loudest track, “Be the Colour” which peaks at approximately -1.5 dBFS with a DR of 13. All other tracks feature lower peak and DR values.

Figure 4.1.2

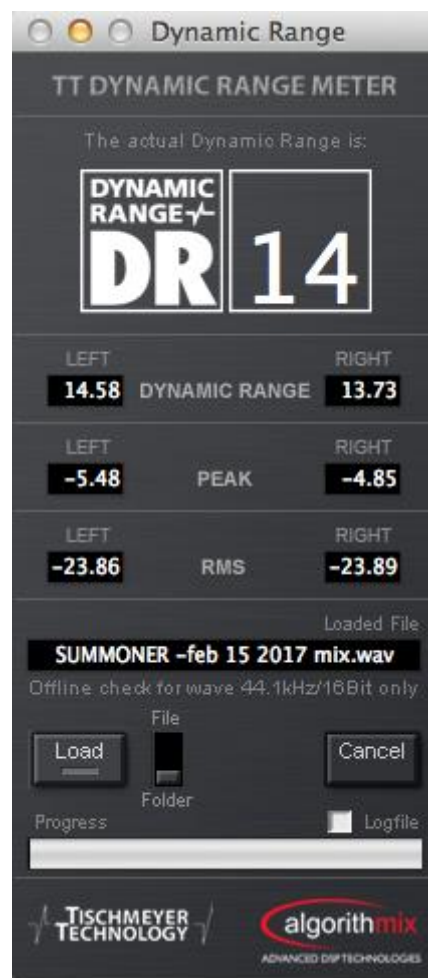

This image shows the DR reading for “Summoner,” which peaks around -5 dB with a DR of

14.

After listening to the record critically, and comparing each song’s spectral configuration, I noticed that “Be the Colour” also features markedly strong *high-mid* and *high* frequency content. An abundance of these frequencies caused this track to sound louder than the others after I matched their overall levels (Moore 2012: 133). I had to take this difference in frequency distribution into consideration to create a balanced programme.

Capture

Capturing audio into Logic X was a simple task. I had bounced mix files encoded at 96kHz, 24-bit (PCM WAV), so importing these mixes presented no problems (Figure 4.2.1).

Figure 4.2.1



Figure 4.2.1 shows the capture stage of audio mastering. The five tracks from the *Summoner EP* (2017) were imported into *Logic X*.

Signal Processing

As stated in chapter 1, mastering engineers allocate most of their time and attention to signal processing, and the mastering session for *Summoner* (2017) also proceeded this way. The final versions of these tracks were mixed using digital equipment, and since each song predominantly features very loud sub-bass and low-frequency information, I decided to process these tracks *in-the-box*, or, without outboard processing equipment.¹²⁰

Before I could begin to address the record's timbral characteristics, I had to balance the overall level of each track. Engineers call this process *normalization*. These levels changed throughout the mastering process, but because the level of "Summoner" was much lower than "Be the Colour" I had to balance these two tracks. If I had not done so, I may have thought that "Summoner" features insufficient low frequency information. However, after raising the level of this track, it became clear that "Summoner" may actually feature more low-frequency content than all the other tracks on the record. Audio example 4.1.1 demonstrates "Summoner" before (00:00-00:15) and after (00:15-00:30) normalization occurred.

To begin normalizing these tracks, I applied a +5 dB gain boost to "falling away from...", as well as "Summoner." Figure 4.3.1 illustrates these tracks before and after this boost was applied. Although additional boosting and dynamic range compression will be incorporated later, I wanted to hear both songs peaking at 0.0 dBFS in order to compare each

¹²⁰ Mastering engineers often opt for an *in-the-box* approach when working on hip hop and EDM records, as clients typically provide *loud* mixes. This is because sensitive outboard equipment often behaves erratically when subject to loud signals with excessive bass frequencies.

track's RMS level; or, as Mark Cousins and Russ Hepworth-Sawyer might say, each track's *body* characteristics (2013: 69). Although commercial tracks should normally peak at around -0.3 dBFS,¹²¹ at this point, I was merely observing each track's DR and RMS characteristics. Indeed, engineers often alter a record's dynamic and timbral characteristics this way before completing the signal processing stage, if only to take note of the sonic results.

Figure 4.3.1

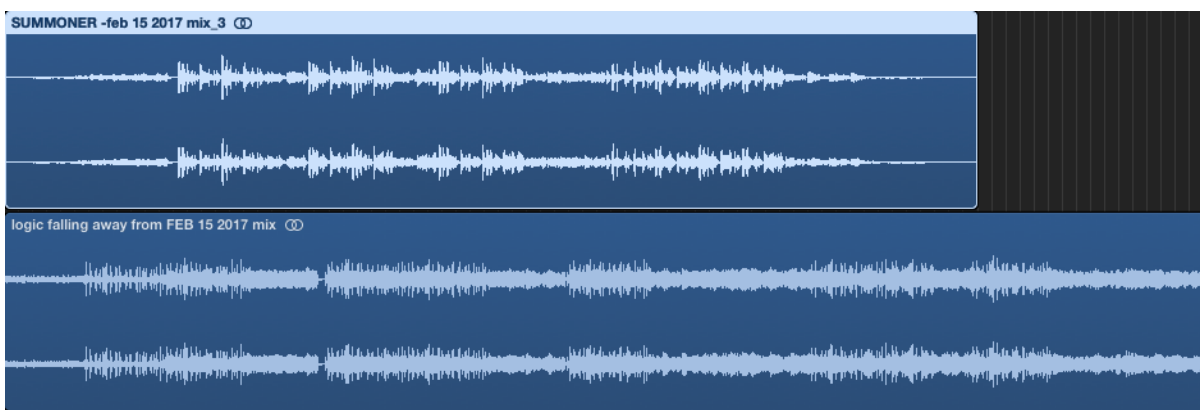

The image above illustrates the amplitude diagrams for “Summoner” (top) and “falling away from...” (bottom) before I normalized the levels. The image below shows the amplitude diagrams for “Summoner” (top) and “falling away from...” (bottom) after a +5dB gain boost was applied. Each track is now normalized to peak at 0.0 db(FS)

¹²¹ According to researchers/mastering engineers Mark Cousins and Russ Hepworth-Sawyer: “The output level is important for several reasons. Firstly, despite our apparent need to run a master right up to 0 dbFS, there’s a potential risk of so-called ‘inter-sample peaks’ as part of the D/A conversion process. Inter-sample peaks can be easily negated by running the output at around -0.3 dbFS” (2013: 162).

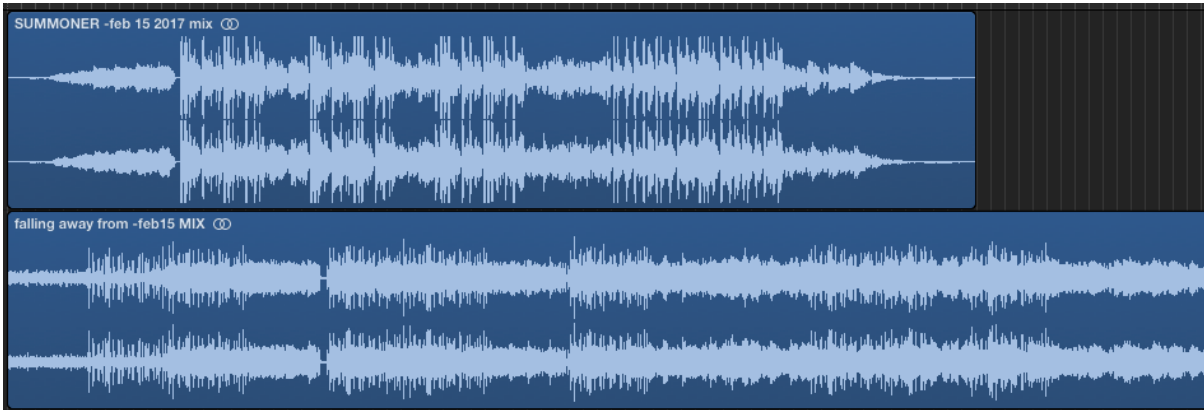

As illustrated in figure 4.3.1, these tracks are quite dynamic compared to other commercially released hip hop records. For instance, readers will notice that both diagrams above feature some large amplitude spikes, and highly distinct *loud* and *soft* sections. Because of this, I applied limiting to the master buss as the first step in dynamic range configuration. While engineers such as Adam Ayan may recommend limiting closer to the end of the mastering process, I felt it was necessary to apply the limiter while adjusting the gain of each track (Hepworth-Sawyer & Hodgson, forthcoming). Because the songs featured on *Summoner* (2017) had markedly different micro and macro dynamic characteristics before mastering, I decided that it would be best to raise the average level of the quietest tracks through a combination of boosting gain and gentle brickwall limiting.¹²² This allowed me to balance the record’s general dynamic characteristics so they conformed to the genre’s broad sonic expectations. These initial steps provided an acceptable starting point.

I demonstrate this approach to limiting in audio example 4.1.2. Here “falling away from...” is presented without limiting (00:00-00:30), and then with limiting applied (00:30-00:45). I followed a similar process for each track. “Summoner” and “falling away from”

¹²² This technique is discussed more fully in Chapters 1 and 2.

were much quieter than the rest of the record and required stronger limiting. While the limiter/gain settings I applied were revisited throughout the signal processing phase, this first step allowed me to better assess each track's spectral characteristics.

After balancing the amplitude levels of these tracks through gain adjustment and gentle limiting, I turned my attention to the record's stereo field characteristics. Before directly modifying the album's spectral characteristics directly via EQ, I wanted to ensure that each track had balanced frequency information throughout the stereo field. To accomplish this, I used an M/S encoder called *Center* (Figure 4.3.2). This allowed me to ensure each track's low-frequency energy was represented in mono. High frequencies, on the other hand, were panned more towards the sides, and using dedicated M/S controls labeled "center" and "sides," I modified each track's spectral representation throughout the stereo field. I noticed, for example, that each track sounded much clearer when the *side* channels were boosted by approximately 2-3 dB. Audio example 4.1.3 presents the song "Summoner" both without the application of M/S processing (00:00-00:30) and with M/S Processing (00:30-1:00).

Figure 4.3.2



Waves' Center plug-in.

After balancing the record's stereo field characteristics, I proceeded to alter each track's spectral content by using FabFilter's Pro-Q software, adjusted to operate in *linear* mode. Although this software provides a detailed FFT analysis of a signal's frequency components, I do not find this information to be useful in a substantive way when mastering records. Instead, I use Pro-Q to audition various boosts and cuts applied to the track. Audio

example 4.1.4 illustrates this process. Listeners will hear the EQ sweeping through different frequency ranges as it applies various boosts and cuts. This exemplifies how engineers audition the effect across a track's spectral configuration.

However, I did not intend to apply the possibilities illustrated in Audio Example 4.1.4 to the record, for I was simply engaging in an experimental evaluative process. After assessing the record in this way, I noticed that “Summoner,” “falling away from...,” “Mobbin’,” and “Villainous” all sound quite *boxy*. Engineers use this term to describe records containing an abundance of low-mid frequency information (Katz 2007: 47). On my record, I assumed that this deficiency was caused by the distortion tools and vinyl/tape samples I used earlier in the creative process. Consequently, I cut the region centered around 350Hz (using a wide Q value) by 1.3 dB on “falling away from...,” “Mobbin’,” and “Summoner.” On “Villainous,” I chose to cut this region by 1.0 dB. I also used a relatively wide Q-range to reduce the frequencies between 200Hz and 650Hz gently.¹²³ In addition, on “Villainous,” I applied a 1.5 dB cut at 85Hz with a narrow Q-value, because the second harmonic of the 808 sub-bass was located here, which previously *cluttered* the track's low-end. As soon as this cut was made, the track sounded far less muddy. Audio example 4.1.5 demonstrates “Villainous” with no such filter applied (00:00-00:30), and then with a gentle cut at 85Hz (00:30-1:00).

After applying gentle EQ cuts to each track on *Summoner* (2017), I proceeded to alter the record's dynamic characteristics. As mentioned in Chapter 2, hip hop typically features both loud records and hypercompression (Shelvock 2017: 179; Hodgson, 2011), and in order to establish a dynamic scheme similar to other hip hop records, I used Waves API 2500 emulator plugin to compress these tracks by up to 6dB (Figure 4.3.3).

¹²³ Hepworth-Sawyer and Hodgson (forthcoming) refer to this technique as *feathering*. A wider Q value makes EQ cuts such as these less perceptually *jarring* for the listener.

Figure 4.3.3



Figure 4.3.3 provides an image of Waves’ API 2500 compressor emulation. The settings I used on “Summoner” are as follows: Threshold — -2 dB; Attack — 10 ms; Release — 3s; Knee — Medium; Detector Thrust — Normal; Make-up gain — +6 dB.

In audio example 4.1.6, I present the song “Summoner” both with and without additional compression. The opening 30 seconds (00:00-00:30) is not compressed, and after a fadeout, I apply the compressor to raise the track’s RMS level (00:30-1:00). Beyond the 30 second mark, listeners should notice a *pumping* effect, which attenuates the entire track each time the kick drum is struck. ¹²⁴

¹²⁴ As mentioned previously, pumping refers to the sound of a compressor attenuating a signal and then restoring its amplitude level so quickly it becomes noticeably audible.

After applying compression, I noticed that the midrange on “Be the Colour” sounded weak. However, since standard EQ boosts often sound quite artificial at the mastering stage, I configured the Brainworx dynamic EQ (bx dyn_EQ) to provide gentle intermittent boosting (+1.5 dB) in the area around 790Hz. I programmed the software to use a wide Q-value, so that frequencies between 600 and 900Hz were also gently boosted.

Audio example 4.1.7 demonstrates the dynamic EQ technique described above. No dynamic EQ is used for the first 30 seconds, and then I apply the device for the remainder of the example. In addition, I used the M/S EQ function in Pro-Q to boost frequencies above 6kHz in the side channels by 0.5 dB. Boosting these high frequencies highlighted the track’s various white noise effects (such as the impacts, risers, and white noise illustrated earlier in Audio Example 3.1.8). Audio example 4.1.8 presents “Be the Colour” without this M/S EQ boost (00:00-00:30), as well as with it (00:30-1:00).

The record sounded satisfactory to my ears with the limiting, compression, linear EQ, and dynamic EQ techniques I had applied, and after I programmed each of these tools to make the record sufficiently loud, with a genre-appropriate timbral scheme, I decided that the signal processing phase was complete. The final DR readings for “Summoner” and “Be the Colour are illustrated in figures 4.3.4- 4.3.5.

Figure 4.3.4

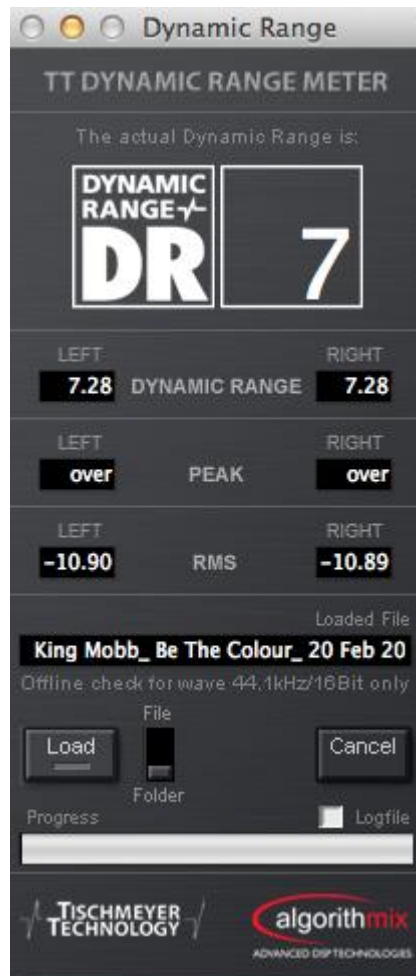

The DR level of “Be the Colour” was reduced from 13 to 7 via dynamic range compression.

Figure 4.3.5

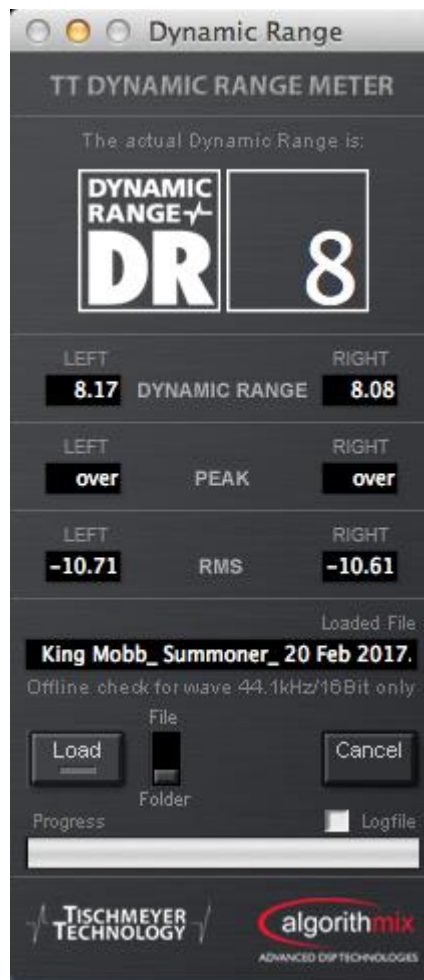

The DR level of “Summoner” was reduced from 14 to 8 via dynamic range compression.

Sequencing

In many cases, mastering engineers establish the sequence of tracks, and this provides the engineer with an opportunity to engage with the record's *narrative* qualities. In this section, I describe my rationale for choosing *Summoner's* final sequence.

I decided on the following track order:

- (i) "Be the Colour,"
- (ii) "Summoner,"
- (iii) "Mobbin',"
- (iv) "Villainous," and
- (v) "falling away from..."

The first track, "Be the Colour" draws the listener in with quiet gamelan instrumentation paired with a hip hop groove. I felt that this uncommon combination might prepare the listener's expectations for the remaining songs. In other words, I wanted to establish the expectation that this record belongs within the tradition of experimental instrumental hip hop. This initial track also features loud and *punchy* drums from beginning to end, similar to the artist Flying Lotus, which I felt provided an attractive opening.

The next track, "Summoner," starts with a fade-in, and a low-pass filter slowly adds high frequency information into the mix over approximately 15s. This transitional moment helps the listeners adjust to a very different type of mix. Indeed, "Summoner" features more tape saturation than the previous track, as well as more prominent low and low-mid frequency information.

From this point, I decided that "Mobbin'" and "Villainous" should become tracks 3 and 4, respectively. Both recordings use a similar sonic palette, and seemed to belong together. In addition, "Villainous" is slightly faster than "Mobbin'," which I felt warranted its position as the record's penultimate track. The record's final song, "fallin away from..." has the fastest tempo on the record.

“Falling away from...” certainly stands out from the other tracks on this record, for although it demonstrates a similar mixing style and instrumentation as tracks 2-4, the arrangement and compositional qualities sound somewhat melancholy. In addition, as the song ends with a long fade out, I felt that “falling away from...” would conclude the record in a mysterious way. In purely subjective terms, this placement sounded as though the imagined *summoner* of the title track, a type of fantasy sorcerer, was fading into the ether, and this imagery connects strongly to the record’s album art (Figure 4.4.1).

Figure 4.4.1



The album artwork for Summoner (2017)

Formatting/Delivery

As with the majority of recently released records, I intend to distribute *Summoner* (2017) primarily through streaming services such as iTunes, Spotify, and Tidal. This album was released on all major digital distribution platforms via CD Baby in February, 2017. I bounced *Summoner* (2017) at 44.1 kHz, 16-bit (PCM WAV) as this is the only format currently accepted by CD Baby.

A major concern for mastering engineers who deliver records for online streaming is that these platforms have different loudness normalization standards, shown in the table below:

Platform	Loudness Normalization Setting
Apple	-16LUFS
Tidal	-14LUFS
YouTube	-13LUFS
Spotify	-11LUFS
Soundcloud	None

Loudness researcher/mastering engineer Ian Shepherd remarks on these different standards (2015):

We know now that all the major music streaming services are using loudness normalization – meaning every song is played at a similar level, aiming for a “target” loudness, which is different for every service. Loud songs are turned down, quiet songs are turned up – *if* there’s enough peak headroom. And because the target level for some platforms is pretty loud, that’s a very significant “if.”

Because when there isn’t enough headroom to lift the level up without clipping, your music either won’t get turned up and will sound quieter than everything else as a result, or it may have extra peak limiting applied to get it up to the target level. Which may or may not sound good. TIDAL doesn’t turn quieter songs up at all. None of these is an ideal situation!

To address this issue, Shepherd recommends aiming for a peak-to-loudness ratio (PLR) that accommodates the chosen platform. PLR is similar to DR, or *crest factor*, as it provides a comparison of a track's peak levels and its average loudness (in LUFS). He states that on all platforms, there is virtually no benefit to mastering records at a higher PLR than -12 LUFS (Shepherd 2015). If one does choose a louder PLR, the track's level may be turned down on all streaming platforms except Soundcloud, which features no loudness normalization.

Most tracks on *Summoner* featured an average loudness of -11 LUFS (figure. 4.4.2). As a result, it is likely that these tracks will be attenuated slightly when streamed on Apple Music, Tidal, or Youtube. As both an artist and a mastering engineer, this is not a concern for me. The average loudness of *Summoner* is very close to Shepherd's recommendations (e.g., -12 LUFS), and the album does not sound noticeably quiet compared to other tracks on Apple Music. Moreover, when this record is streamed using Spotify and Soundcloud, the level is not reduced.

Figure 4.4.2

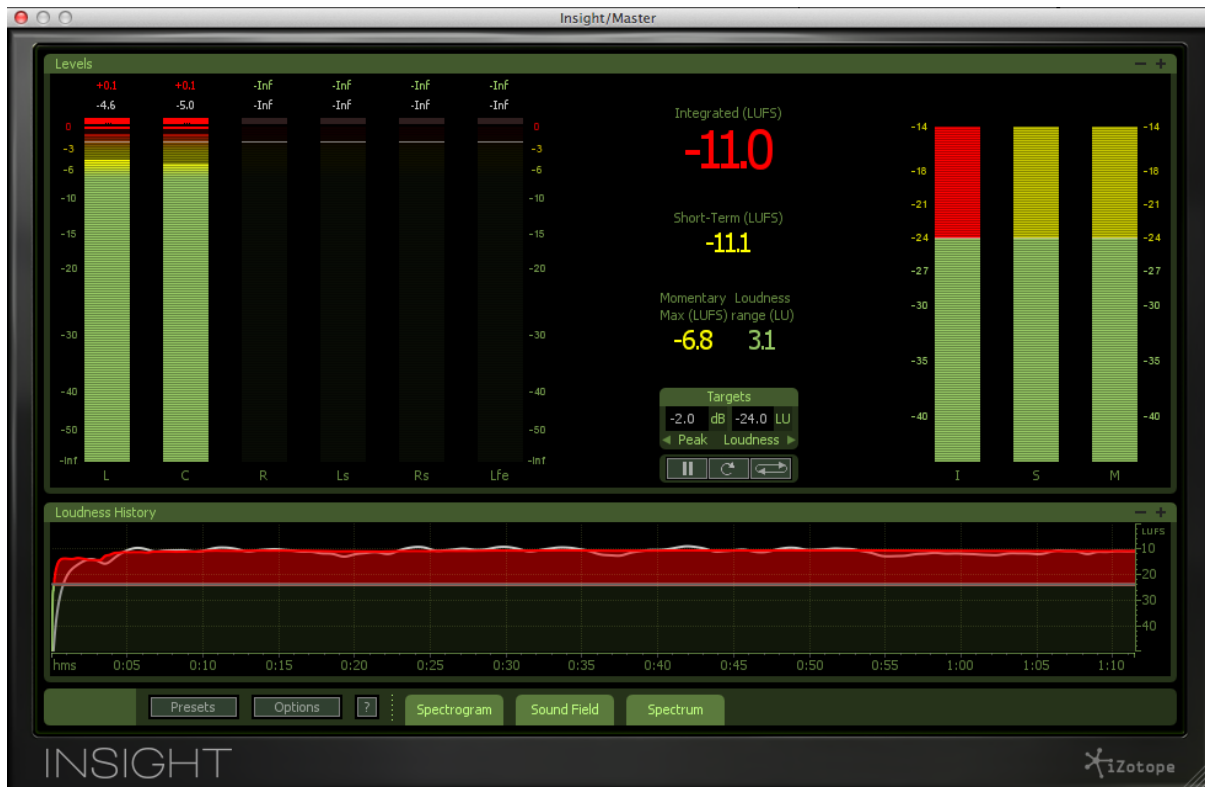

Figure 4.4.2 shows the loudness level of “Summoner” in LUFS. The plug-in pictured above is iZotope’s Insight.

Conclusion

In this dissertation, I have demonstrated that audio mastering is indeed a musical competency, and elucidated the most significant and clearly audible facets of that competence. Indeed, the mastering process impacts traditionally valued aspects of records, such as timbre and dynamics. By applying the emerging *creative scholarship* method used within music production studies (MPS), Chapters 1-4 helps scholars learn to *hear* and understand audio mastering by elucidating its core practices as *musical* endeavours. And, in so doing, I have attempted to foster increased clarity and accuracy in future scholarly discussions on the topic of audio mastering, and its products.

Record production is a variegated process, and it always ends with mastering. Even if an individual tracks, mixes, and masters a project, each of these steps occurs in distinct stages. It is impossible, for instance, to record (or *track*) and master an album at exactly the same time. With the advent of MPS as a recognized sub-discipline in the broader field of musical inquiry, scholars require research that effectively disentangles these practices. For this to happen, record-making methods, such as audio mastering, require increased scholarly engagement. As editors Simon Zagorski-Thomas and Simon Frith remark (2012, back cover):

The playback of recordings is the primary means of experiencing music in contemporary society, and in recent years 'classical' musicologists and popular music theorists have begun to examine the ways in which the production of recordings affects not just the sound of the final product but also musical aesthetics more generally. Record production can, indeed, be treated as part of the creative process of composition. At the same time, training in the use of these forms of technology has moved from an apprentice-based system into university education. Musical education and music research are thus intersecting to produce a new academic field: the history and analysis of the production of recorded music.

While numerous musicologists study records — or, the *products* of record production practice — MPS scholars directly analyze record-creation methods and techniques. In fact,

musicologists often use records as *evidence* of record production.¹²⁵ The MPS paradigm, on the other hand, examines the techniques of record-making (Hodgson 2010; Zagorski-Thomas 2012). While records occasionally provide evidence of standard production techniques in the MPS paradigm, these studies directly focus on commonly used production techniques. In other words, MPS scholarship analyzes the *inputs* of record creation instead of only the *outputs*.¹²⁶

In general, the application of record production methods occurs in highly individualized ways, and this unites much of the available MPS literature. Although trade-based literature abounds on how to operate a compressor or a DAW, for example, these guides often fail to acknowledge the *creative* aspects of audio engineering and production. By this, I refer to the *instrumental* quality that production tools take-on when operated by creative agents. Brian Eno remarked on this phenomenon in 1979, in his article “The Recording Studio as a Compositional Tool.” He explains some of the creative aspects of music production as follows (in Boss 1979)¹²⁷:

Each channel on the mixer is a long strip. Generally at the bottom is a level control, for how loud you want that channel to play back. Next up, normally, there's a pan control, for where you want the sound object in the stereo/quad image. Next up is an echo control, and echo is really a separate issue, which has to do with something very unique to recording: briefly, it enables you to locate something in an artificial acoustic space. There's also equalization - a device by which you can create a timbral change in an instrument, which in rock music is especially important, because many different rock records, in my opinion, are predicated not on a structure, or a melodic line, or a rhythm, but on a sound; this is why studios and producers keep putting their names on records, because they have a lot to do with that aspect of the work. Apart from equalization, there are other facilities which are widely used, such as limiting, compression - which has the effect of altering the envelope of a note or an instrument, so you can do something I've been interested in, creating hybrid instruments.

¹²⁵ Please see, for example: Zak (2001) or Katz, M. (2004).

¹²⁶ Some books and articles written before 2012 also fit the MPS paradigm. Examples include Hepworth-Sawyer (2009, 2011). Hodgson (2010, 2011), Izhaki (2008), Katz (2007), and others cited throughout this dissertation's main chapters. However, this field was not concretely defined until 2012 (Zagorski-Thomas).

¹²⁷ This article was re-transcribed digitally from a Downbeat Magazine feature originally published in 1979 by David Boss. It is available at http://music.hyperreal.org/artists/brian_eno/interviews/downbeat79.htm

Compression is quite interesting over a whole track; if you're using severe compression and limiting at the same time, when you push one instrument up, the track is governed so that the overall level will never change. Pushing one instrument up effectively pushes the others down, so all you do is alter the ratio between the instruments where you make a move. I started to use this as a deliberate, compositional, sound-type device; it's generally been ignored or regarded as a misuse of the equipment before, but I'll let you judge for yourself. On Helen Thormdale from the No New York album (*Antilles*), I put an echo on the guitar part's click, and used that to trigger the compression on the whole track, so it sounds like helicopter blades.

Naturally, all of these things are variable throughout the entire course of the music. These are the kinds of things that you, as a listener, don't generally notice; some of them operate almost subliminally - they are the *ambiance* of a track, not the obvious aspects of the track. Those are very much the things that traditional production is concerned with. And they allow you to rearrange the priorities of the music in a large number of ways.

Indeed, Eno argues that studio practices widely believed to be strictly *technical* in nature are actually highly creative endeavours. Thus, MPS scholars bridge the gap between trade literature on production tools and the scholarly assessment of these tools.

In order to situate this dissertation within the MPS tradition, I have both analyzed the musical contributions of mastering engineers, and surveyed the technologies they use to finalize records. In chapter one, for instance, I described how phenomenological evaluation of a record's timbral and dynamic configuration informs every audio mastering session.¹²⁸ Indeed, human subjectivity informs the mastering process, and no two engineers sonically configure records in exactly the same way. While all mastering sessions include discrete capture, signal processing, sequencing, and delivery stages, what actually occurs during these stages remains variable. Hence, to explain how audio mastering proceeds, I opted to describe the broad application of many accepted techniques and tools. However, this does not mean that I provided a comprehensive "how-to" guide in any sense. Such a task is currently

¹²⁸ An exception may be LANDR's automatic mastering service. However, this service has yet to be accepted within elite production circles. In addition, amateur recordists and musicians also avoid using this service, often commenting that humans simply do a better job.

impossible to accomplish with any precision, especially when considering the importance of phenomenological evaluation to the art of audio mastering.

I instead provided a case study (Chapter 4), which elucidated how I mastered a commercially released EP I had created (*kingmobb*). This case study includes numerous audio and visual examples of the mastering sessions for this record, in addition to descriptions of each step. I included this case study because MPS scholars generally insist that researchers possess the record production skills which they critique or analyze.¹²⁹ For example, one cannot substantively comment upon the application of EQ or compression in audio mastering without also possessing the skills to operate these tools.

In fact, many MPS documents rely heavily upon audio demonstration, and, indeed, it would be a daunting task to educate readers on the nuances of audio mastering via text alone. To do so would be akin to “dancing about architecture,” to use a commonly cited analogy.¹³⁰ Text certainly remains a valuable medium for assessing record production techniques such as audio mastering; however, audio demonstration and written are often intertwined in MPS literature. As a result, this academic paradigm encourages the existence of *creative scholars* whose work has been *peer-reviewed* by the recording industry itself.¹³¹ This dissertation, and my published research, are examples of this type of creative scholarship (Shelvock 2011, 2012a, 2012b, 2014, 2016, 2017, forthcoming: Routledge/FocalPress).

In fact, scholars in the UK actively combine audio engineering pedagogy and traditional scholarship, and have done so for several years. *Joint Audio Media Education Support* (JAMES) provides accreditation to schools offering courses on MPS throughout the UK, and this group’s advisory board consists of audio professionals and academics alike.

¹²⁹ Many of these researchers are cited throughout the dissertation. See, for example: Cousins & Hepworth-Sawyer (2013), Hepworth-Sawyer (2009, 2010), Hepworth-Sawyer & Hodgson (2017, forthcoming), Hodgson (2010, 2011, 2014), and Shelvock (2011, 2012, 2014, 2016, 2017)

¹³⁰ This quote is attributed to Martin Mull, and several other artists, comedians, and actors.

¹³¹ A non-exhaustive list of scholars who participate in this tradition include Gary Brohman, Mark Cousins, Ruth Dockwray, Phil Harding, Russ Hepworth-Sawyer, Jay Hodgson, Justin Patterson, Rob Toulson, and myself.

Readers may be surprised to learn, for instance, that approximately 26 post-secondary schools in the UK possess this accreditation, schools which provide both diploma and degree-based programs. Thus, MPS even demonstrates a strong scholarly presence at the undergraduate level.

In order to contribute to this growing MPS tradition, I honed my audio mastering skills by assisting Dr. Jay Hodgson of Jedi Mastering and MOTTOSound. I also actively engaged in my own mastering practice, and I continue to do so. Some of the professional work I acquired while completing this dissertation includes work by Scott Brunelle, Stacy Zegers, CCMA-nominated group Runaway Angel, and a project featuring musicians from the Crash Test Dummies (Checkered Eye).¹³² As mentioned in Chapter four, I have also mastered my own work, which is available on Spotify and iTunes (and others) under the moniker *kingmobb*. In addition, I worked as an assistant engineer with Dr. Hodgson on numerous critically acclaimed releases, such as Juno-nominated work by Concubine (2016).¹³³ These experiences prepared me to contribute to ongoing scholarly discussions on the topic of audio mastering — an area which is currently led by *creative scholars*.¹³⁴ In fact, I simply could not have undertaken this dissertation without learning to master records.

The mastering skills I deepened while writing this dissertation enabled me to convey to readers the musical ramifications of standard audio mastering tools and techniques. However, as covered in Chapter one, audio mastering practices routinely change as new technology develops. In fact, audio mastering initially emerged in the 1940s as a solution to new technological possibilities, and it continues to change, for the recording industry continually requires new and innovative solutions for finalizing records. As such, audio

¹³² Runaway Angel — <http://www.runawayangelmusic.com/> ; Scott Brunelle — <https://scottbrunelle.bandcamp.com/> ; Checkered Eye — <http://www.checkeredeye.com/> ; Stacey Zegers — <http://www.musicsolutions.com/artists/stacey-zegers/>

¹³³ Concubine — <http://junoawards.ca/nomination/2016-electronic-album-of-the-year-concubine/>

¹³⁴ See, for example, Cousins & Hepworth-Sawyer (2013), Hepworth-Sawyer & Hodgson (forthcoming), Hodgson (2010), Nardi (2014), and Shelvock (2012).

mastering remains a topic open to further discussion in the future, as the recording industry embraces these new technologies and methods. Thus, I consider my work on this topic to be a catalyst for scholars seeking to understand audio mastering as it evolves.

WORKS CITED AND CONSULTED

- Advanced Television Systems Committee. (2013). *Techniques for Establishing and Maintaining Audio Loudness for Digital Television*. Accessed from <http://atsc.org/wp-content/uploads/2015/03/Techniques-for-establishing-and-maintaining-audio-loudness.pdf> April 9, 2017.
- Anderton, C. (2004). "Audio Mastering in Your Computer" *Sound on Sound*, August issue
- Aphex (2001). "Instruction Manual." Aphex Sound.
- Audio Engineering Society. (1998). "AES standard method for digital audio engineering — Measurement of digital audio equipment." *Audio Engineering Society*.
- Ballou, G. (2013). *Handbook for sound engineers*. Taylor & Francis.
- Bartlett, Bruce and Henny. (2005). "Practical Recording Techniques: THE Step-By-Step approach to Professional Audio recording, 4e. Boston: Focal Press.
- Brainworx (2011). "Dynamic EQ." User Manual.
- BBE Sound, Inc. (2016). "882i: Sonic Maximizer." User Guide and Reference Manual.
- Camerer, F. (2010). *On the way to loudness Nirvana: Audio Leveling with EBU R 128*. EBU Tech.
- Camilleri, L. (2010). *Shaping sounds, shaping spaces*. *Popular Music*, 29(02), 199-211.
- Case, A. (2012). *Sound FX: unlocking the creative potential of recording studio effects*. CRC Press.
- Christ, S. (2015) "Jimmy Page: Led Zeppelin Re-masters are Better than Originals" in *Music Times*. Accessed March 2017 at: <http://www.musictimes.com/articles/24278/20150112/jimmy-page-led-zeppelin-remasters-better-than-originals.htm>
- Cook, N. (2015). "Performing Research: Some Institutional Perspectives." *Artistic Practice as Research in Music: Theory, Criticism, Practice*. Ed. Dogantan-Dack Ashgate Publishing, Ltd..
- Cousins, M., Hepworth-Sawyer, R. (2013) *Practical Mastering*. Focal Press
- Deruty, E. (2011). "Dynamic Range and the Loudness War." *Sound on Sound*. Accessed online at www.soundonsound.com
- Deruty, E., & Tardieu, D. (2014). About dynamic processing in mainstream music. *Journal of the Audio Engineering Society*, 62(1/2), 42-55. Chicago
- Dogantan-Dack, M. (Ed.). (2015). *Artistic Practice as Research in Music: Theory, Criticism, Practice*. Ashgate Publishing, Ltd.
- Dow, R. (2011). "Creative Mid/Side Processing". *Sound on Sound*. Accessed online at www.soundonsound.com
- Droney, M. & Massey, H. (2001) "Compression Applications." TC Electronic.
- Droney, M. (2003) *Mix Masters: Platinum Engineers Reveal Their Secrets For Success*. Boston: Berklee Press.
- Eisengrein, D. (2007). "Do the Dip: Sidechains." *Remix Magazine*. Available online at: www.remixmag.com
- Feilder, L.D. (1981). "Dynamic Range Requirement for Subjective Noise Free Reproduction of Music" *Audio Engineering Society*. AES Convention 69.
- Fox, C. (2014, May). "The art of noise: how music recording has changed over the decades." *The Guardian*.
- Franz, D. (2004). *Recording and Producing in the Home Studio*. Boston: Berklee Press.

- Frith, S., & Zagorski-Thomas, S. (Eds.). (2012). *The art of record production: an introductory reader for a new academic field*. Ashgate Publishing, Ltd..
- Gallagher, M. (2008). *Mastering Music at Home*. Thomson.
- Gallagher, M. (2009). *The music tech dictionary: a glossary of audio-related terms and technologies*. Cengage Learning.
- Giannoulis, D., Massberg, M., & Reiss, J. D. (2013). "Parameter automation in a dynamic range compressor." *Journal of the Audio Engineering Society*, 61(10), 716-726.
- Gibson, B. (2002a). *Sound Advice on Compressors, Limiters, Expanders & Gates*. Hal Leonard.
- Gibson, B. (2004). *Sound Advice on Equalizers, Reverbs and Delays*. Hal Leonard.
- Gibson, B. (2002b). *Sound Advice on mixing*. Hal Leonard.
- Grey, J. M. (1977). "Multidimensional perceptual scaling of musical timbres." *Journal of the Acoustical Society of America*, 61(5), 1270-1277.
- Haas, H. (1972). The influence of a single echo on the audibility of speech. *Journal of the Audio Engineering Society*, 20(2), 146-159.
- Haas, W. (2008). "The SOS guide to Mix Compression" *Sound on Sound*. Accessed online at www.soundonsound.com
- Harvey, S. (2013). "The Development of dynamic range control." *GC Pro Audio Solutions*, Spring ed.
- Hepworth-Sawyer, R., Golding, C. (2011). *What is Music Production? A Producer's guide: the role, the people, the process*. Focal Press.
- Hepworth-Sawyer, R., Hodgson, J. (forthcoming). *Audio Mastering: The Artists*. Routledge/ Focal Press
- Hepworth-Sawyer, R., Hodgson, J. (2017). *Perspectives on Music Production: Mixing Music*. Routledge/ Focal Press.
- Hodgson, J. (2010) *Understanding Records*. Continuum.
- _____. (2014) *Representing Sound*. WLA Press
- Houghton, M., White, P. (2008) "What's the Frequency?" *Sound on Sound*. Accessed online at www.soundonsound.com
- Howell, S. (2006). "What's the difference between phasing and flanging?" *Sound on Sound*. Accessed online at www.soundonsound.com
- Huber, D. M., & Runstein, R. E. (2013). *Modern recording techniques*. CRC Press
- ITU-R. (2015). *Algorithms to measure audio programme loudness and true-peak audio level*. Accessed online at: https://www.itu.int/dms_pubrec/itu-r/rec/bs/R-REC-BS.1770-4-201510-I!!PDF-E.pdf April 8, 2017.
- Izhaki, R. (2013). *Mixing audio: concepts, practices and tools*. Taylor & Francis.
- iZotope. (2013) "How to add tape saturation to your mastering chain." Online at <https://www.izotope.com>
- Katz, B. (2007) *The Art and Science of Audio Mastering*. Focal Press
- Katz, M. (2010). *Capturing Sound: how technology has changed music*. Univ of California Press.
- Kehew, B and Ryan, K. (2008). *Recording the Beatles: The Studio Equipment and Techniques Used to Create Their Classic Albums*. Houston: Curvebender.
- Langford, S. (2011). *The Remix Manual*. Focal Press.
- Langford, S. (2013). *Digital Audio Editing: Correcting and Enhancing Sound With DAWs: Correcting and Enhancing Audio in Pro Tools, Logic Pro, Cubase, and Studio One*.
- Lund, T. (2011). *ITU-R BS.1770 Revisited*. TC Electronic. Accessed online at <https://www.tcelectronic.com/media/1017421/lundt013011.pdf> April 8, 2017
- Marrington, Mark (2016) *Reconciling theory with practice in the teaching of songwriting*.

- Cambridge Companion to the Singer Songwriter*. Eds. Williams, Katherine and Williams, Justin A., (eds.) Cambridge University Press, pp. 267-277
- Marrington, Mark (2017, In Press) "Composing with the Digital Audio Workstation." In: *The singer-songwriter handbook*. Williams, Justin and Williams, Katherine, (eds.) Bloomsbury
- Martin, B. (2014, October). "Headstock Resonances in the Electric Bass Guitar." In Audio Engineering Society Convention 137. *Audio Engineering Society*.
- _____. (2016). "Mixing Popular Music in Three Dimensions: Expansion of the Kick Drum Source Image." *Innovation in Music II*, 14.
- Massenburg, G. (1972). "Parametric Equalization." In *Audio Engineering Society Convention 42*. Audio Engineering Society.
- McGuire, S. & Pritts, R. (2013) *Audio Sampling: A Practical Guide*. Taylor & Francis.
- Milner, G. (2011). *Perfecting Sound Forever: The story of recorded music*. Granta Books.
- Modern Mixing. (2015). "Psychology of a Mix Engineer: Interview with Phil Tan." *Modern Mixing*. Accessed online at <http://modernmixing.com/blog/2015/02/18/psychology-of-a-mix-engineer-phil-tan/> April 12, 2017.
- Moore, B. C. (2012). *An introduction to the psychology of hearing*. Brill.
- Moylan, W. (1992). *The Art of Recording: The Creative Resources of Music Production and Audio*. Kluwer Academic Pub.
- Nardi, C (2014). *Gateway of Sound: Reassessing the Role of Audio Mastering in the Art of Record Production*. Dancecult (online).
- Neate, R. (2013, September). "Dr Dre Beats valued at more than \$1bn following Carlyle deal." *The Guardian*.
- Owsinski, B. (2008). *The Mastering Engineer's Handbook: The Audio Mastering Handbook*. Cengage Learning.
- Palermino, C. (2015). "Vinyl Sales Are on the Rise in 2014". Digital Trends. Accessed March, 2017 at: <http://www.digitaltrends.com/music/vinyl-revival-continues-q1-2015/>
- Pohlmann, K. C. (2006). Measurement and evaluation of analog-to-digital converters used in the long term preservation of audio recordings. (Paper, Presented at) " Issues in Digital Audio Preservation Planning and Management", Washington, DC.
- Robjohns, H. (2006). "What is Aliasing, and What Causes it?" *Sound on Sound*. available online at: www.soundonsound.com
- _____. (2007). "Dynamics Processors" *Sound on Sound*. available online at: www.soundonsound.com
- _____. (2010) "Analog Warmth" *Sound on Sound*. available online at: www.soundonsound.com
- _____. (2013) "Is there a difference between clipping and limiting?" *Sound on Sound*. available online at: www.soundonsound.com
- _____. (2014) "What Does a Compressor's Auto-Release Do?" *Sound on Sound*. available online at: www.soundonsound.com
- _____. (2016) "Intersample Peaks" available online at: www.soundonsound.com
- Ronan, M., Nicholas, W., & Robert, S. 2.1. "Exploring the Sound Quality Dimensions of Hypercompression" in *. Innovation in Music II*, Eds. Patterson, Toulson, Hepworth-Sawyer, Hodgson. Future Technology Press, 39.
- Ryan, K., & Kehew, B. (2008) *Recording the Beatles*. New York, NY: Curvebender Publishing.
- Senior, M. (2008). "How should I compress a classical recording?" *Sound on sound*. available online at: www.soundonsound.com
- Serrà, J., Corral, Á., Bogañá, M., Haro, M., & Arcos, J. L. (2012). Measuring the evolution of contemporary western popular music. arXiv preprint arXiv:1205.5651.

- _____. (2014) *Recording Secrets for the Small Studio*. Focal Press.
- Shelvock, M. (2011) "Interview with Josh Leo" *Journal on the Art of Record Production*. Online
- _____. (2012a) "Interview with Ben Fowler" *Journal on the Art of Record Production*. Online
- _____. (2012b) "Interview with Steve Marcantonio" *Journal on the Art of Record Production*. Online
- _____. (2014) "The Progressive Heavy Metal Guitarist's Toolkit: Digital and Analog Strategies." *Innovation in Music*. Eds. Patterson, Toulson, Hepworth-Sawyer, Hodgson. Future Technology Press
- _____. (2016) "Gestalt Theory and Mixing Audio." *Innovation in Music II*. Eds. Patterson, Toulson, Hepworth-Sawyer, Hodgson. Future Technology Press
- _____. (2016) "Groove and the Grid: Mixing Contemporary Hip Hop." *Perspectives on Music Production: Mixing Music*. Eds. Hepworth-Sawyer, Hodgson. Routledge/Focal Press
- Sonnox. (2007) *Fraunhofer IIS Pro Codec User Guide*. Accessed from <http://dload.sonnoxplugins.com/pub/plugins/manuals/SonnoxFPCMan.pdf> April 8, 2017.
- Southall, N. (2006). Imperfect sound forever. *Stylus Magazine*, 1.
- Sreedhar, S. (2007). "The future of music." *IEEE Spectrum*.
- Toft, R. (2010). *Hits and Misses: Crafting Top 40 Singles, 1963-1971*. A&C Black.
- Universal Audio. (2009). "Model 2-1176: Dual 1176LN Limiting Amplifier." UAD.
- Vickers, E. (2010, November). The loudness war: Background, speculation, and recommendations. In *Audio Engineering Society Convention 129*. Audio Engineering Society.
- Waddell, G. (2013). *Complete Audio Mastering: Practical Techniques*. McGraw Hill.
- Watson, B. (2012). "M/S Mastery." *Sound on Sound*, available online at: www.soundonsound.com
- White, P. (2001). "Equalisers Explained." *Sound on Sound*, available online at: www.soundonsound.com
- _____. (2003) "More of Everything! Maximizing the Loudness of Your Masters." *Sound on Sound*, available online at: www.soundonsound.com
- _____. (2006) "Mixing Essentials: The Fundamentals of Mixing." *Sound on Sound*, available online at: www.soundonsound.com
- _____. (2009) "Creating A Sense of Depth in Your Mix: Mix Processing Techniques." *Sound on Sound*, available online at: www.soundonsound.com
- _____. (2010) "Distortion in the Studio." *Sound on Sound*, available online at: www.soundonsound.com
- _____. (2012) "Noise Reduction: Tools and Techniques." *Sound on Sound*, available online at: www.soundonsound.com
- Wyner, J. (2013). *Audio Mastering: Essential Practices*. Berklee Press, Boston.
- Zagorski-Thomas, S. (2007). "The musicology of record production." *Twentieth-century music*, 4(02), 189-207.
- Zak, Albin. (2001). *The Poetics of Rock: Cutting Tracks, Making Records*. University of California Press.

MATTHEW T. SHELVOCK

Curriculum Vitae

EDUCATION

- | | | |
|--------------|--|------------------|
| Ph.D. | The University of Western Ontario
Musicology
Advisor: Dr. Jay Hodgson
Advisory Board: Dr. Robert Toft, Dr. Kevin Mooney
Dissertation Proposal: <i>Audio Mastering as a Musical Competency</i> | 2012-
Present |
| M.A. | The University of Western Ontario
Popular Music and Culture
Advisor: Dr. Jay Hodgson
Committee: Dr. Norma Coates, Dr. Robert Toft, Dr. Matt Stahl, Dr. Samuel Trosow
Thesis: <i>Audio Mastering as Musical Practice</i> | 2010-2012 |
| B.A. | The University of Western Ontario
Popular Music Studies
Film Studies (dual major degree) | 2006-2010 |

PUBLICATIONS

- 2019 — (Forthcoming) Shelvock, M. "Understanding and Hearing Microrhythm in Electronic Production." *Perspectives on Music Production: Ear Training*. Routledge/Focal Press. (Eds.) Dr. Jay Hodgson, Russ Hepworth-Sawyer.
- 2018 — (Forthcoming) Shelvock, M. "Hip Hop Production: Interview with Ray Moulin of Self Serve Records." *Perspectives on Music Production: Production*. Routledge/Focal Press. (Eds.) Dr. Jay Hodgson, Russ Hepworth-Sawyer. ISBN: 978-0415789226.
- 2018 — (Forthcoming) Shelvock, M. "Hip Hop Production and the Actor-Network Ontology" *Perspectives on Music Production: Production*. Routledge/Focal Press. (Eds.) Dr. Jay Hodgson, Russ Hepworth-Sawyer. ISBN: 978-0415789226.

- 2016 — Shelvock, M. “Groove and the Grid: Mixing Contemporary Hip Hop” *Perspectives on Music Production: Mixing Music*. Routledge/ Focal Press. (Eds.) Dr. Jay Hodgson, Russ Hepworth-Sawyer. ISBN: 978-1138218734.
- 2016 — Shelvock, M. “Gestalt Theory and Mixing Audio.” *Innovation in Music: Transactions*. (Future Technology Press). ISBN 978-1911108047.
- 2014 — Shelvock, M. “The Progressive Heavy Metal Guitarist’s Signal Chain: Contemporary Digital and Analogue Strategies.” *Innovation in Music*. Future Technology Press. p. 126-138. ISBN 978-0-9561516-8-1.
- 2012 — Shelvock, M. “Audio Mastering as Musical Practice.” Electronic Dissertation and Thesis Repository, The University of Western Ontario.
- 2012 — Shelvock, M. “Interview with Ben Fowler.” *Journal on the Art of Record Production*, 6.
- 2012 — Shelvock, M. “Interview with Steve Marcantonio.” *Journal on the Art of Record Production*, 6.
- 2011 — Shelvock, M. “Interview with Josh Leo.” *Journal on the Art of Record Production*, 5.

CONFERENCES

Invited Presentations and Papers:

- 2017 — American Musicological Society (AMS): “Gestalt and the Groove: Analyzing Microrhythm in Hip Hop Production.” University of Toronto. (Conference Paper)
- 2017 — International Association for the study of Popular Music (IASPM): *Music and Belonging*. Paper: “Groove and the Grid: Microrhythmic Production Strategies in the Vancouver Hip Hop Scene.” University of Toronto. (Conference Paper)
- 2016 — Don Wright Faculty of Music Research Colloquium: “Audio Mastering as a Musical Competency in Record Production.” (Colloquium Presentation)
- 2015 — Innovation in Music II: “Gestalt Theory and Mixing Audio.” Anglia Ruskin University, Cambridge, UK. (Conference Paper)
- 2015 — Don Wright Faculty of Music Research Day: The University of Western Ontario, London, Ontario, Canada. “Raving for Introverts.” (Audio Technology Art Installation)
- 2014 — Imagining Canada’s Future 2014 — SSHRC Regional Event — Big Data in the SSHRC Disciplines — Data from the Past, Present, and Future. “Chromacoustics/ Lumacoustics.” (Audio Technology Art Installation)
- 2013 — Western University Graduate Symposium on Music 2013: London, Ontario, Canada. “Audio Mastering as Musical Practice.” (Conference Paper)

2013 — Innovation in Music: “The Progressive Heavy Metal Guitarist’s Signal Chain: Contemporary Analogue and Digital Strategies.” University of York and York St. John University, UK. (Conference Paper)

Administration:

2016 — Steering Committee/Founding Member: *Perspectives on Music Production* — International Conference Initiative.

2014 — Western University Graduate Symposium on Music 2014: Conference Chair.

2013 — Western University Graduate Symposium on Music 2013: Programme Committee.

GUEST LECTURES AND DEPARTMENTAL PRESENTATIONS

October 2016 — Faculty Research Forum. “Gestalt Theory and Record Analysis.” The University of Western Ontario, London, ON.

March 2016 — “Sampling and Hip Hop: Chopping the Supremes”; Desktop Music Production. UWO.

February 2016 — “Synthesis and Sound Design for Dubstep/EDM: Beyond Presets”; Desktop Music Production. UWO.

January 2016 — “An Introduction to DAW-Based Music Production in Ableton and Logic.” UWO.

November 2015 — “Contemporary DAW-based Songwriting and Production: Philosophy and Practices.” UWO.

November 2015 — “Audio Mastering: Strategies for EQ and Compression.” UWO.

October 2015 — “Audio Mastering and the Analysis of Popular Recordings.” UWO.

March 2015 — “Digital Audio Workstations and Contemporary EDM: Technology and Music Making.” UWO.

March 2011 — “Gender in Death Metal, Black Metal, and other Extreme Genres.” UWO.

November 2010 — “Masculinity in Extreme Heavy Metal: Sonic and Cultural Considerations.” UWO.

2013-2015 — Workshop Series (Guitar): Topics on improvisation, fretboard harmony, and technique. Walters Music, London, ON, Canada.

SERVICE

2016 — Organizing Committee — FIMULAW Interdisciplinary Research Day, Western University, March 2017.

- 2016 — (Forthcoming, Feb 2017) — Proofing/Subject Matter Expert: *Audio Mastering: The Artists*. Routledge/Focal Press. ISBN 978-1138900059.
- 2016 — Steering Committee/Founding Member: *Perspectives on Music Production* — Print Journal. (Eds. Russ Hepworth-Sawyer, Jay Hodgson, Mark Marrington)
- 2015 — Peer Review: *Transactions on Innovation in Music* (Future Technology Press). ISBN 978-1911108047.
- 2014 — Conference Chair: Western University Graduate Symposium on Music. Keynote Speaker: Prof. Michael Coghlan, York University.
- 2014 — Peer Review: *Innovation in Music* (Future Technology Press). ISBN 978-0-9561516-8-1.
- 2013 — Digital Editor and Committee Member. *Popular Music in Practice*. (Eds Dr. Jay Hodgson and Russ Hepworth-Sawyer). (Former) Online journal.
- 2013 — Committee Member: Western University Graduate Symposium on Music. Keynote Speaker: Jay Hodgson, Western University

CITATIONS AND MEDIA COVERAGE

- 2015 — Paper from Innovation in Music 2015 conference reviewed in Audio Media International Magazine: <http://www.audiomediainternational.com/show-news/inside-innovation-in-music-2015/04504>
- 2014 — Cited in leading Electronic Music Journal: Nardi, C. (2014). Gateway of Sound: Reassessing the Role of Audio Mastering in the Art of Record Production. *Dancecult: Journal of Electronic Dance Music Culture*, 6(1), 8-25.
- 2012-Present — MA thesis downloaded 1500 times from Western University's digital thesis repository. Top referrers: Wikipedia, Google

SELECT PRODUCTION AND ENGINEERING CREDITS

2017	0100110110, <i>1818 EP</i> (Naked Lunch: NLD386). Portugal.
2017	M'NK x mobb <i>ELEMENTAL</i> . (Ghostape: GT002). London, ON
2017	0100110110, <i>1111</i> (Tarvisium Electornique: TAEL009). Treviso, Italy.
2017	Acharné, <i>Innocence and Suburbia</i> (Seppuku Records: SPK007). Berlin, DE.
2017	Acharné, <i>Innocence and Suburbia</i> — <i>Student Is Teacher Remixes</i> (Seppuku Records: SPK008). Berlin, DE.
2017	Blaenk Minds, <i>Twisted Skater</i> (Areal Records: AREAL086). Berlin, Germany.
2017	Cabaret Nocturne, "Moon Invaders," <i>Slow Porn Presents: Prise de Vue</i> (My Favorite Robot Records: MFR151D). Toronto, CA.
2017	Donna Mackenzie, <i>Handful of Dirt</i> (Desert River Records: DR004). London, CA.
2017	Dress Black, <i>Future Songs</i> (Independent: 2017). Toronto, CA
2017	Eskimo Twins, <i>The Fridge Click EP</i> . (Beachcoma: BEACH059). Berlin, Germany
2017	Fairmont, <i>Shadows of Mine</i> (Suara: SUARA275). Barcelona, Spain.
2017	Fumoir, <i>Mile Ender</i> . (Beachcoma: BEACH061). Berlin, Germany
2017	Julian Grefe, <i>Nil</i> (Areal Records: AREAL088). Berlin, Germany
2017	Jay Hodgson Quartet, <i>String Quartet No. 1: Gutei's Finger</i> (Desert River Records: DR002). London, CA.
2017	Jay Hodgson Quartet, <i>Daitsu Chisho Buddha: song for shakuhachi, tape delay & river</i> (Desert River Records: DR003).
2017	Kingmobb, <i>Summoner</i> (Ghostape: 191061409946). London, CA.

2017 Kingmobb, *KNGMXBB xII* (Ghosttape: 191924026273). London, CA.
 2017 Maden, *Opening* (MVMT: MVMT049). London, England.
 2017 Maden, "Falling," *Sound of Whartone Miami 2017* (Whartone Records: WHADA029). London, England.
 2017 Norwell, *Still Her* (Beachcoma: BEACH060). Berlin, Germany.
 2017 Night Vision, *DHL Mix #124* (Deep House London: <https://soundcloud.com/deep-house-london>). London, UK.
 2017 Night Vision, *Vines* (Bad Pony Records: BP039). Montreal, CA.
 2017 Oslvanger, *Mental Contest* (Karakter Records: K#003). Amsterdam, NE
 2017 The Raucous Sues, "Diamond Day" (Desert River Records: DR001). London, CA
 2017 Switchdance, *The Black Tape* (Karakter Records: K#002). Amsterdam, NE.
 2017 John Tejada & Arian Leviste, *Switched Mode* (Areal Records: AREAL087). Berlin, Germany
 2016 Various Artists, *Life's A Beach vol. 5* (Beachcoma Records: 4056813028089). Berlin, Germany.
 2016 Acharné, *Stars* (DCR: DCR0008). Berlin, Germany.
 2016 Acharné, *Doubt* (DCR: DC005). Berlin, Germany.
 2016 Acharné, *Innocence & Suburbia* (TBD). Sydney, Australia.
 2016 Blaenk Minds, *Twisted Skater*. (Areal Records: Areal086). Berlin, Germany.
 2016 Buran, *Hirst* (Beachcoma: BEACH052). Berlin, Germany
 2016 Cabaret Nocturne, *Blood Walk* (Beachcoma: BEACH054). Berlin, Germany
 2016 Cha Ching Ching, *OVO Sound Video Showcase* (Instrumental Films). London, CA
 2016 Dawad, *Ike*. (Beachcoma: BEACH057). Berlin, Germany
 2016 Deepchild, *Backroom Outtakes* (DCR: DCR006). Berlin, Germany
 2016 Deepchild, *Baller* (Goldmin Music: gmd020). Paris, France
 2016 Deepchild, *Flames* (DCR: DCR004). Berlin, Germany
 2016 Deepchild, *Queer Mechanics* (DCR: DCR007). Berlin, Germany
 2016 Deepchild, *Stars* (DCR: DCR008). Berlin, Germany
 2016 Fairmont, *Carthage ep.* (My Favourite Robot Records: MFR150). Toronto, CA
 2016 Fairmont & SwitchSt(d)ance, *Precinct*. (Beachcoma: BEACH053). Berlin, Germany
 2016 Fairmont & SwitchSt(d)ance, *Ancient Dust*. (Areal Records: AREAL081). Berlin, Germany
 2016 Frank Costanza, "Major Minor" (Independent Release). London, CA.
 2016 Fumoir, *Lovedroids* (Beachcoma: BEACH051). Berlin, Germany
 2016 Gameboyz, *Freedom* (Beachcoma: BEACH058). Berlin, Germany
 2016 Gothic, *Reims ep* (Gothic Romance GR001). Sovizzo, Italy.
 2016 Gothic, *Arcadia ep* (Gothic Romance GR002). Sovizzo, Italy.
 2016 Gothic, *Spleen ep* (Gothic Romance GR003). Sovizzo, Italy.
 2016 John Tejada & Arian Leviste, *Switched Mode* (Areal Records: AREAL087). Berlin, Germany.
 2016 LAL, *Find Safety* (Coax Records: <https://www.coaxrecords.com/store/lal-find-safety-2016>). Toronto, CA
 2016 The Lifers, *Out and In* (Dungus Records: <http://www.dungusrecords.com/thelifers/>). London, CA
 2016 Low Manuel, *The Squid/Octopus* (Beachcoma: BEACH054). Berlin, Germany
 2016 Maden, *Faster Stronger EP* (Whartone Records, WHAD028). London, UK.
 2016 Maden, *Stay Tuned EP* (Whartone Records, WHAD038). London, UK.
 2016 Metope, *Night Zero* (Areal: Areal083). Berlin, Germany
 2016 Mountain of Wolves, "Never Coming Home/Deep Dark Woods" (independent release: 7" vinyl). London, CA
 2016 John Muirhead, *Yesertday's Smile*. (Self release: <https://open.spotify.com/album/3X9RSKTH0XTR0sKnRwQyF>). London, CA
 2016 Muséum, *Little Dead Things* (New Kanada: NK62). Berlin, Germany
 2016 Poesy, *The Spotless Mind* (Independent release: <https://poesy.bandcamp.com/releases>). Toronto, Canada.
 2016 The Raucous Sues, "Diamond Day" (Desert River Records: DR001). London, CA
 2016 Room 303, *Beyond the Sea Promo Mix* (Next Level Leta: <https://soundcloud.com/nextlevelleta>). Vancouver, CA
 2016 Room 303/Tim Baresko, "Marilyn Monroe" *Defected Presents: Most Rated Ibiza 2016* (Defected: RATED24D2). London, UK
 2016 Room 303/Tim Baresko, "Marilyn Monroe" *Poolside Miami 2016* (Toolroom: TOOL45601Z). Ibiza, Spain
 2016 Room 303/Sean Roman, "Close The Door" *New York Deep* (Recovery House: RHCOMP2326). New York, USA
 2016 Room 303/Sean Roman, "Close The Door" *Armada Deep House Selection Vol. 8* (Armada: ARDI3606). Amsterdam, NE
 2016 Room 303/Sean Roman, "The Way You Love Me" *Street Kings Present: Summer 2016* (Street King: KSD327).
 2016 Room 303/Sean Roman, "Storm (REMIX)" *REFLECT: Deep House* (Reflective: RMCOMP349).
 2016 Room 303, "Look At Me" *The Deeper We Go...* (Recovery Tech: RTCOMP867). New York, USA
 2016 Skull Rock, *Fünfhatz/Plukaki* (Beachcoma: BEACH055). Berlin, Germany
 2016 Sleepy Mean, *The Long Rewind* (Independent release: <https://sleepymeans.bandcamp.com>). Toronto, Canada.
 2016 Switchst(d)ance, "Arabian Ride," *Flash#02* (Rock To The Beat Records: RTTB024). Montpellier, France
 2016 Marco Tegui, *Strings EP* (Independent release: <https://soundcloud.com/marcotegui/sets/marco-tegui-strings-ep-free>)
 2016 John Tejada & Arian Leviste, *Hysteresis* (Areal Records: AREAL087: VINYL release). Berlin Germany
 2016 Transcode, *Blood Moon* (Carton-Pate Records: CPR027).
 2016 Undo, *Aeromuerto* (Beachcoma: 4250644893643). Berlin, Germany
 2015 Various Artists, *Lazerwhales III* (Areal Records: AREAL079). Berlin, Germany
 2015 Various Artists, *Life's A Beach vol. 4* (Beachcoma Records: 4250644893612). Berlin, Germany.
 2015 Various Artists, *Ambient Parks Vol 2* (New Kanada: NK56). Berlin, Germany.
 2015 Acharné, *Beauty Tithe*. (Seppuku Records: SPK006). Berlin, Germany.
 2015 Concubine, *Concubine* (Independent Release: <https://concubinesound.bandcamp.com/releases>) Berlin, Germany
 2015 Deepchild, *Golden Moments in American Manufacturing* (HarmoniusDiscord:HD041) Austin, USA
 2015 Deepchild, *Black EP* (Danse Club Records: DCR019). Berlin, Germany
 2015 Deepfunk, *Musca* (Beachcoma: BEACH043). Berlin, Germany.
 2015 Five Oceans, *From What You've Heard*. (Independent Release). London, Canada.
 2015 Jori Hulkkonen, *Death by Semantics* (Areal Records: Areal078). Berlin, Germany.
 2015 Heretic & Buran, *Perilous* (Beachcoma: BEACH048). Berlin, Germany.
 2015 Kara-Lis Coverdale, *Afirtouches* (Sacred Phrases: SP-56). Audio Cassette. Fort Wayne, USA.
 2015 KNTRL, *The Awkward Age* (Beachcoma: BEACH045). Berlin, Germany
 2015 Low Manuel, *Valkyria Remixes*. (SixtySevenSuns: Sixty007). Malta.
 2015 Low Manuel, *The Storm* (Beachcoma: BEACH044). Berlin, Germany
 2015 Major/Minor, *Songs For The Campfire* (Independent Release). London, CA
 2015 Max Dahlhaus, *Above* (Beachcoma: BEACH039). Berlin, Germany
 2015 Nathan Jonson, *Towards the Sun* (Areal Records: AREAL082). Berlin, Germany

2015 Nikki's Wives, "Ghost" (Pretty Money Records: Rel4Sep2015). Toronto, CA
 2015 Nikki's Wives, "Lonely Being Cool" (Pretty Money Records: Rel4Sep2015). Toronto, CA
 2015 The Lifers, "Home For The Weekend" (Dungus Records: DGR15). Toronto, CA.
 2015 Oddane Taylor, "Been Broke" (Self produced). Toronto, CA.
 2015 Pink Skull, *Infant Decimal e.p.* (Beachcoma Records: BEACH047). Berlin, Germany.
 2015 Room 303 & Marco Tegui, *Since You've Gone EP* (Stereomono: SMR007). Italy.
 2015 Room 303 & Sean Roman, *Make You Cry* (Sleazy Deep: SLEAZY058). London, UK
 2015 Sid Le Rock, *Mount Hope* (Beachcoma: BEACH040). Berlin, Germany.
 2015 Sid Le Rock, *Dayglo/Dextro e.p.* (Area;" AREAL080). Berlin, Germany.
 2015 Sigward & Oliver Sudden, *Sunburst* (Beachcoma: BEACH041). Berlin, Germany.
 2015 Spoke And Mirror, *Volume For A Vacuum* (Self-produced). Waterloo, CA.
 2015 SwitchSt(d)ance, *No Man's Land*. (Areal: AREAL076). Berlin, Germany.
 2015 SwitchSt(d)ance, *Daydreaming*. (Beachcoma: BEACH042). Berlin, Germany.
 2015 John Tejada & Arian Leviste, *Reactance* (Areal Records: Areal77). Vinyl. Berlin, Germany
 2015 The Breath & the Bellows, *Say* (Independent Release). London, Canada.
 2015 Marco Tegui, *All About Love* (Sleazy Deep: SLEAZY057). London, UK
 2015 Terrorista, *Terrorista/Outer Rooms cassette* (independent release). Toronto, Canada
 2015 Undo, *Aeromuerto* (Beachcoma: 4250644893643). Berlin, Germany
 2015 Will Maden-Wilkinson, *Giles EP* (for personal DJ set). London, UK.
 2015 Yuri Parparcen, "Complete Control (feat. Courtney Lewis)" (Hypnotic Mindscapes). Toronto, Ca
 2015 Yuri Parparcen, "Here We Are (feat. Courtney Lewis)" (Hypnotic Mindscapes). Toronto, Ca
 2014 Various Artists, *Ambient Parks Compilation* (New Kanada: NK48). Berlin, Germany
 2014 Various Artists, *Seppuku005* (Seppuku Records: SPK005). Berlin, Germany
 2014 Acharné, *Doubt* (Seppuku Records: SPK001). Berlin, Germany
 2014 Acharné, *Rooms Without Walls* (Seppuku Records: SPK003). Berlin, Germany
 2014 Acharné, *Rooms Without Walls Remixes* (Seppuku Records: SPK004). Berlin, Germany
 2014 Ambalance, *Staring Problems* (Independent Release). Berlin, Germany
 2014 Ambalance, *Are You Around?* (Independent Release). Berlin, Germany
 2014 Auk, *Absolution* (Thoughtless Music: TLM095). Berlin, Germany
 2014 Steve Aries, *Electric Sunset* (Victims Music Company: VIC002). Montreal, Canada.
 2014 Atlantik, *Gezeitenkönig* (Areal Records: Areal075). Berlin, Germany
 2014 Banquet, "Bowline" (Independent: Bandcamp 05 Nov 2014). Toronto, Canada
 2014 Barcelona, "Background (Ted Hunter Remix)" (Universal/Motown: E-Release). New York, USA
 2014 KTRL, *Night Shifts* (Beachcoma: BEACH038). Berlin, Germany
 2014 Kara-Lis Coverdale, *A-480* (Constellation Tatsu: CTSUFL14). Oakland, USA.
 2014 Deepchild, *Rebuild* (Seppuku Records: SPK002). Berlin, Germany
 2014 Deepchild, "Basement Rites" *Leisure System Data*. (Leisure System: LSD1). Berlin, Germany
 2014 Deepchild, *Slave Driver* (Thoughtless Music: TLM097). Berlin, Germany
 2014 Deepfunk, *Mistakes Are Blue* (Beachcoma: Beach032). Berlin, Germany
 2014 Fairmont, *Grizzly* (Beachcoma: Beach036). Berlin, Germany.
 2014 Falana, *Things Fall Together* (Falana Music: FM01). Toronto, Canada.
 2014 Rennie Foster, *Perimeter Abstract* (Thoughtless Music: TLM099). Berlin, Germany.
 2014 Gone Deville, *Crossroad Traffic* (Mile End Records: MILE264). Montreal, Canada.
 2014 Gone Deville, "Downfall," *Poolside Miami* (Toolroom: TOOL28502z). Ibiza, Spain.
 2014 Gone Deville, "Downfall," *Poolside Miami Sampler* (Toolroom: TOOL28503z). Ibiza, Spain.
 2014 Gone Deville, "Room 303: Wanting More" *Ibiza Poolside* (Toolroom: TOOL29520). Ibiza, Spain.
 2014 Gone Deville, *So Many Ways* (Casbour Records: CSR010). Montreal, Canada.
 2014 Gone Deville, "Wanting More Remix" *LoveStyle Records: #BeatportDecade Deep House*. (LoveStyle Records: LSRDECADE02). Budapest, Hungary.
 2014 Gyptian, *Live at the London Music Hall Video Promo* (Roofless Creations). Kingston, Jamaica.
 2014 Tomas Jirku, *Solaris* (Thoughtless Music: TLM089). Berlin, Germany
 2014 KNTRL, *Night Shifts* (Beachcoma: BEACH038). Berlin, Germany.
 2014 Lock Smith, *Settle Down Na* (Thoughtless Music: TLM098). Berlin, Germany
 2014 Low Manuel, *The Beach* (Beachcoma: BEACH034). Berlin, Germany
 2014 Low Manuel, "Ontario," *Balearic Bangers: Best of Ibiza 2014* (KNM: 4250644776737). Ibiza, De
 2014 Metro4, "The Dream" (Independent Release). Toronto, CA
 2014 Metope, *The Beacon* (Beachcoma: BEACH037). Berlin, Germany.
 2014 MNR, "Dubfield" *Sangria Vol. 3* (Sangria: SNG018). Detroit, USA
 2014 MNR, "Malawi" *Shapes001* (Symmetric Records: SYMM005). Amsterdam, NDLND
 2014 Murr, *Dive Deeper* (Thoughtless Music: TLM088). Berlin, Germany
 2014 Danielle Nicole, *True Romance* (Thoughtless Music: TLM090). Berlin, Germany
 2014 Noah Pred, *Third Culture Remixed*. (Thoughtless Music: TLM093). Berlin, Germany.
 2014 Noah Pred, *ERA TWO* (Thoughtless Music: TLM100). Berlin, Germany
 2014 NOTV, "From Loving You (Remix)," *Best of 2013* (Mile End: MILE240). Montreal, CA
 2014 Norwell, *Her* (Beachcoma: BEACH035). Berlin, Germany
 2014 Norwell, "Her," *Balearic Bangers: Best of Ibiza 2014* (KNM: 4250644776737). Ibiza, De
 2014 Andi Numan, *Freaks Back* (Thoughtless Music: TLM096). Berlin, Germany
 2014 Arthur Oskan, *Primitive Waves* (Beachcoma: BEACH031). Berlin, Germany
 2014 Arthur Oskan, *Back In Black* (Thoughtless Music: TLM092). Berlin, Germany
 2014 Matt Quinney, *Said & Done* (Independent Release). Toronto, CA
 2014 The Rebel Bunch, *Ready To Ride* (UpToDate Records: B00JA0H95K). Munich, Germany
 2014 Room 303, *Wanting More* (LoveStyle Records: LSR018). Budapest, Hungary
 2014 Room 303, "Wanting More: Gone Deville" *Ibiza Poolside* (Toolroom: TOOL29520). Ibiza, Spain.
 2014 Room 303/Jonathan Rosa "Storm (Remix)" (Blue Music Records: BLU031). Florida, USA
 2014 Room 303, "Look At Me" (Sleazy Deep: SLEAZY062). London, UK
 2014 Room 303, "Look At Me" *Amsterdam Sleaze* (Sleazy Deep: Futuresleaze007). London, UK
 2014 Room 303, "Make You Cry" *Ibiza Sleaze, Vol.2* (Sleazy Deep: SLEAZY050). London, UK
 2014 Room 303, *Night Vision* (Electronic Groove: EGNU.007). Montreal, Canada.
 2014 Room 303, *Keep Pushin'* (Da Way: DW026). Montreal, Canada.
 2014 Room 303, *Nightmix*. (VICE Magazine/THUMP: 28X14). Montreal, Canada

2014 Martin Roth, "From Loving You (Gone Deville)," *Mile End Records #BeatportDecade Deep House*. (Mile End Records: MILEDECADE). Montreal, Québec.

2014 Clara Stegall & Ted Hunter, "And I Know" (Next Gen Records: NG1403). New York USA

2014 Sid Le Rock, *Lake Superior* (Beachcoma: 4250644841385). Berlin, Germany.

2014 Side Le Rock, *Safe Word* (Areal Records: AREAL074). Berlin, Germany.

2014 Signal Deluxe, *Violet Offset* (530Techno: 530D019). California, USA

2014 Signal Deluxe, *Zero Seven* (Thoughtless Music: TLM091). Berlin, Germany

2014 Stone Owl, *Sweaty Disco Balls* (Thoughtless Music: TLM094). Berlin, Germany

2014 Symbio, *Refraction* (530 Techno:530D020). California, USA

2014 Marco Tegui, *All About Love*(Sleazy Deep: SLEAZY057). London, UK

2014 Various Artists, *Life's A Beach Vol. 3* (Beachcoma: 4250644867415). Berlin, Germany.

2013 Ambalance, *Discard* (Independent Release). Berlin, Germany

2013 And The Kids, *Neighbors* (Independent Release). Boston, USA

2013 Shane Berry, *Akaforme* (Thoughtless Music: TLM074). Berlin, Germany

2013 Alland Byallo, *Bygones* (Thoughtless Music: TLM079). Berlin, Germany

2013 Canson, *Don't Stop* (Thoughtless Music: TLM076). Berlin, Germany

2013 Carlos Castano, *Children of House* (Mikita Skyy: MSKY036). Toronto, CA

2013 Hector Couto, "Tell Somebody (Remix)," *Best of 2012* (Mile End: MILE1999). Montreal, CA

2013 Demassi, *Sunseeker* (Mikita Skyy: MSKY038). Toronto, CA

2013 Demuir, *The Groove* (Mikita Skyy: MSKY039). Toronto, CA

2013 Ivan Dbri, *US* (530 Techno: 530D017). California, USA

2013 dBiscuits, *Biscuits & Logistics vol -1: Hertzoggy* (Shotgun Records: SR002). London, CA

2013 Deepchild, *I Woke And You Were Smiling* (Thoughtless Music: TLM075). Berlin, Germany

2013 Deepchild, "Black Jesus" (Convex Industries: CSPT115). Berlin, Germany

2013 Deepchild, "Pushing Matter/Lazarus" (Caduceus Records: CDR007). Berlin, Germany.

2013 Deepchild, "Modern Love" *For Every Moment* (Adjunct Audio: ADIG25). Los Angeles, USA

2013 Deepchild, *Bethania* (Caduceus: CDRD#7). Berlin, Germany

2013 Demuir, *Lilac Chaser* (Mikita Skyy: MSKY040). Toronto, CA

2013 Dick Diamonds, *Acid Flex* (Mikita Skyy: MSKY041). Toronto, CA

2013 DJ Zenta, *Inspiration* (Mikita Skyy: MSKY044). Toronto, CA

2013 False Image, *Tunga* (Get Physical: GPMN235). Berlin, Germany

2013 False Image, *Wild Kingdom* (Get Physical: GPM211). Berlin, Germany

2013 Gbor, *Party* (Mikita Skyy: MSKY-38). Toronto, CA

2013 Gone Deville, "Electric Sunset (Remix)" (Victims Music Company: VIC002), Montreal, CA

2013 Gone Deville, *From Loving You* (Mile End: MILE214). Montreal, CA

2013 Gone Deville, "Tell Somebody" *Chez Nous Vol 4* (Mile End: MILE2063). Montreal, CA

2013 Richard Gracious, *Old Things* (Independent Release). London, CA

2013 Graze, *Graze* (New Kanada: NK42). Berlin, Germany

2013 Jak, *Juncture* (530Techno: 530D016). California, USA

2013 LAL, *Figure 2.3.7* (Another Sun: AS2013) Toronto, CA

2013 Lance Romance, "Howlin" (Champion Beats: CHAMP098). London, CA

2013 Larry Jefferson, *Solutions* (530Techno: 530D018). California, USA

2013 Matt Maaskant, *Outside The Cave Remixes* (New Kanada: NK39). Berlin, Germany

2013 Mister Gavin, *Everythang* (Mikita Skyy: MSKY037). Toronto, CA

2013 MNR, *Spectral Visions* (Sangria: SNG008). Detroit, USA

2013 MNR, *The Fabric of Our Reality* (Sangria: SNG017). Detroit, USA

2013 Murr, *Broken Down* (Mikita Skyy: MSKY034). Toronto, CA

2013 Noah Pred & Jay Tripwire, *Find Your Way* (Affin Records: AFFIN118). Berlin, Germany

2013 NOTV, *Keep Movin* (Casbour Records: CSR009). Montreal, CA

2013 Imugem Orihasam, *Not For Body* (New Kanada: NK37). Berlin, Germany.

2013 Platypus, *Argyle* (Thoughtless Music: TLM072). Berlin, Germany

2013 Poacher, *Wormwood* (Independent Release). London, CA

2013 Pupa Bajah, *Under The Cotton Tree* (Native Groove: NG001). Sierra Leone, Africa

2013 Tom Pooks, *Never Without Charlie* (Casbour Records: CSR008). Montreal, CA

2013 Daniel Ray, *Warm Black* (Thoughtless Music: TLM078). Berlin, Germany

2013 The Rebel Bunch, *Man Forges* (Amazing Records: AR04). Munich, Germany

2013 Jason Short, *Low Down Dirty Shame* (Thoughtless Music: TLM073). Berlin, Germany

2013 Stone Owl, *Chemtrails* (Trapez Records: TRAPEZ138). Berlin, Germany

2013 Tazz, *Science Friction* (New Kanada: NK40). Berlin, Germany.

2013 Haoni Teano, *Losing* (Mikita Skyy: MSKY031). Toronto, CA/Paris, France.

2013 Allen Walker, *Solanin* (Mikita Skyy: MSKY040). Toronto, CA

2012 4k feat. Blaze & Jay-Z. "Encore (Radio Edit)" (Roc Nation Roster Artist, 2011-2012). New York, USA

2012 Ambalance, *Cokewave* (Independent Release). Berlin, Germany

2012 Blaze & Rammy-C, "Won't Leave US" (Island Def Jam: 147122). New York, USA

2012 Ethan Borshansky, *Hold Tight* (Thoughtless Music: TLM062). Berlin, Germany

2012 Co-op, *North of Bloor* (Thoughtless Music: TLM064). Berlin, Germany

2012 Hector Couto, *Tell Somebody* (Toolroom: TOOL17102Z). Ibiza, Spain

2012 Deepchild, *Neukolln Burning* (Thoughtless Music: TLM069). Berlin, Germany

2012 Incredible Melting Man, *Heisenberg* (Champion Beats: CHAMP073). London, CA

2012 Incredible Melting Man, *Bass Drum* (Champion Beats: CHAMP082). London, CA

2012 Brian Johnson, *All of the Time* (Thoughtless Music: TLM065). Berlin, Germany.

2012 Demuir, *Suck + Blow* (Mikita Skyy: MSKY035). Toronto, CA

2012 Dig Devil Dig, *I Felt It... But Not That Much* (Independent Release). London, CA

2012 Halfbreed, "Back In The Day" (Chenier Beats: CB02). London, CA

2012 Derek Marin, *We've Been Expecting You* (Thoughtless Music: TLM066). Berlin, Germany

2012 Danyka Nadeau, *Second Best* (Champion Beats: CHAMP080). London, CA

2012 Nigel Richards, *Bangagong* (Thoughtless Music: TLM058). Berlin, Germany

2012 Noah Pred, *Monotasking* (Thoughtless Music: TLM063). Berlin, Germany

2012 NOTV, *Jackson Street* (Casbour Records: CSR007). Montreal, CA

2012 Arthur Oskan, *Exit Strategy* (Thoughtless Music: TLM071). Berlin, Germany

2012 Platypus, *Soft Spoken Trees* (Thoughtless Music: TLM067). Berlin, Germany
2012 Daniel Ray, *Night Watchman* (Thoughtless Music, TLM061). Berlin, Germany
2012 James Rose, *A Capella* (Independent Release). London, UK.
2012 Santini & Tellez, *Lost Thoughts* (Thoughtless Music: TLM059). Berlin, Germany
2012 Solvoid, #3: *Sway/Forshadows/Wronged* (Independent Release). Berlin Germany
2012 Solvoid, #2: *Locksmith/Mendicant/Precipice* (Independent Release). Berlin Germany
2012 Solvoid, #1: *Trespass/Extricate/Huntress* (Independent Release). Berlin Germany
2012 Stare5, *The Sprawl* (Thoughtless Music: TLM060). Berlin, Germany
2012 Stone Owl, *Planet X* (Thoughtless Music: TLM070). Berlin, Germany
2012 Allen Walker, *Muiz Street* (Mikita Skyy: MSKYY033). Toronto, CA