

SORT 41 (1) January-June 2017, 159-176

DOI: 10.2436/20.8080.02.56

A Bayesian stochastic SIRS model with a vaccination strategy for the analysis of respiratory syncytial virus

M. Jornet-Sanz,¹ A. Corberán-Vallet,¹ F.J. Santonja^{1,*} and R.J. Villanueva²

Abstract

Our objective in this paper is to model the dynamics of respiratory syncytial virus in the region of Valencia (Spain) and analyse the effect of vaccination strategies from a health-economic point of view. Compartmental mathematical models based on differential equations are commonly used in epidemiology to both understand the underlying mechanisms that influence disease transmission and analyse the impact of vaccination programs. However, a recently proposed Bayesian stochastic susceptible-infected-recovered-susceptible model in discrete-time provided an improved and more natural description of disease dynamics. In this work, we propose an extension of that stochastic model that allows us to simulate and assess the effect of a vaccination strategy that consists on vaccinating a proportion of newborns.

MSC: 62P10.

Keywords: Infectious diseases, respiratory syncytial virus (RSV), discrete-time epidemic model, stochastic compartmental model, Bayesian analysis, intervention strategies.

1. Introduction

Effective surveillance and control measures are essential to protect public health by rapidly detecting and responding to outbreaks of infectious diseases, which pose a growing threat to human health. Shortcomings in surveillance, vaccines and treatment can result in rising morbidity and mortality. Innovative surveillance methods have been

* e-mail: Francisco.Santonja@uv.es

¹ Department of Statistics and Operational Research. Universitat de València. Faculty of Mathematics. Dr. Moliner, 50. 46100 Burjassot, Spain.

² Institute for Multidisciplinary Mathematics. Universitat Politècnica de València. Building 8G, 2 Floor, Camino de Vera s/n. 46022 Valencia, Spain.

Received: July 2016

Accepted: January 2017

recently developed in an effort to improve outbreak detection capabilities. Numerous epidemiological models have also been proposed to simulate and analyse the impact of different vaccination strategies from an economic and sanitary point of view. Nowadays, the use of models is considered as an effective tool to both represent the evolution of diseases and assess the impact of control interventions (World Health Organization, 2016).

Most of the approaches that are currently used to study the impact of vaccination programs fall into one of the following two categories: compartmental mathematical models (Acedo et al., 2010; Hogan et al., 2016; Van Hoek et al., 2011; Christensen et al., 2013; Yu et al., 2016) or computer models defined through complex schemes of interaction (Pérez-Breva et al., 2014; Vannia et al., 2012; Craig et al., 2014; Poletti et al., 2015). Compartmental models divide the population being studied into a set of distinct compartments according to the disease status (for instance, the susceptible-infected-recovered model divides the population into three categories) and model the evolution of infectious diseases through changes in the number of individuals in each compartment. They are usually based on ordinary differential equations, which imply a continuous-time deterministic model. Besides, they are defined assuming that all the individuals in the population are equally likely to contact any other individual (Ma and Li, 2009; Brauer, 2008). However, contact patterns in real populations are indeed more heterogeneous. Therefore, models involving homogeneous mixing should be replaced by models incorporating stochastic effects (Brauer, 2008). Stochastic models are able to accommodate the stochasticity inherent in the transmission of infection by considering that the number of individuals in each compartment is a random variable with its associated probability distribution (Allen, 2008). In addition, stochastic models can be easily analysed from a Bayesian viewpoint (see, for example, Gibson and Renshaw, 1998; O'Neill, 2002; Boys and Giles, 2007; Weidemann et al., 2014).

A Bayesian stochastic susceptible-infected-recovered-susceptible (SIRS) model in discrete time has been recently proposed to model respiratory syncytial virus (RSV) dynamics in the region of Valencia, Spain (Corberán-Vallet and Santonja, 2014). The proposed model, which can be seen as a discrete time Markov chain model (Allen, 2008), does not imply mass-action mixing of individuals in the population. In addition, the probability of disease transmission depends on a transmission rate that is allowed to vary stochastically over time. This feature is fundamental to provide an accurate representation of the disease dynamics.

RSV is the most important cause of lower respiratory tract illness in infants and children worldwide. It causes repeat infections throughout life and significant disease in pediatric and elderly population. Due to the high burden of disease globally, RSV has been a priority for vaccine development. However, efforts to develop a safe and effective vaccine have yet to lead to a licensed product (Anderson et al., 2013; Jones et al., 2014; Higgins, Trujillo and Keech, 2016; Roberts et al., 2016). The epidemiology and burden of RSV disease point to several target populations for vaccines, which may require different vaccination strategies according to the age. The highest priority tar-

get population are infants < 6 months of age who are at highest risk of severe disease. The enhanced disease observed after a formalin-inactivated RSV (FI-RSV) vaccine directed development of RSV vaccines toward live virus vaccines. Yet these young infants present challenges to vaccine development. They may not respond well to a vaccine because of immature immune system, suppression of the immune response by presence of maternal antibody, and an elevated susceptibility to disease with live RSV infection. The second target population are children ≥ 6 months of age, both to prevent their disease and potential transmission to younger children. The third target population are pregnant women, since high titers of maternally derived RSV antibody have been shown to correlate inversely with the incidence and severity of RSV infection in the first six months of life. This maternal vaccination strategy would protect newborns both by placental transfer of antibodies and by blocking transmission (Dudas and Karron, 1998). However, it would not provide protection for children beyond 4–6 months of age, and so this strategy would be followed by direct child vaccination as maternal antibody wanes. The last target population are the elderly, who are also at risk for severe disease. See Higgings et al., 2016 for a current summary of RSV vaccine research and development.

Taking into account recommendations for RSV vaccine development (Anderson et al., 2013), we present here an extension of the model proposed in (Corberán-Vallet and Santonja, 2014) that allows us to simulate and assess the impact of vaccination programs. Because most efforts are directed towards immunizing infants from birth to six months (Beeler and Eichelberger, 2013), the simulated strategy consists on vaccinating a proportion of newborns. This strategy is similar to the one implemented in (Acedo et al., 2010).

2. Case study

Our study focuses on weekly hospitalizations for RSV-related illnesses among children younger than two years of age in the Spanish region of Valencia. Children aged < 2 years are the target population most problematic by possible severe complications. On some occasions, hospitalization may be necessary, especially for RSV bronchiolitis and pneumonia.

In particular, we have data on the number of new hospitalizations per week from week beginning January 1st 2001 to week beginning December 20th 2004 (see Figure 1). As can be seen, RSV activity presents a clear seasonal pattern: epidemics occur yearly between late fall and early spring.

Acedo et al. (Acedo et al., 2010) proposed a compartmental model based on ordinary differential equations to describe these data and perform a vaccination program analysis. They assumed that the sizes of the susceptible, infected, removed and vaccinated populations were large enough so that the mixing of individuals in the population was homogeneous. However, that is not the case, specially at the beginning of epidemics. In

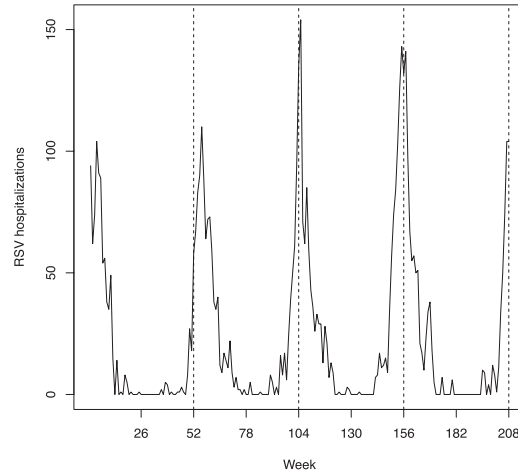

Figure 1: Hospitalizations for respiratory syncytial virus (RSV) infection among children aged < 2 years from week beginning January 1st 2001 to week beginning December 20th 2004 in the Spanish region of Valencia.

addition, the transmission rate was modeled assuming the same seasonal pattern for all the years, which is not a realistic description of the data.

Corberán-Vallet and Santonja (Corberán-Vallet and Santonja, 2014) proposed a stochastic SIRS model in discrete time that provided a precise representation of the pattern of disease. That model was also able to quite accurately identify the start of a new RSV epidemic and its increase. However, vaccination strategies were not studied. Similar to that study, we also confine our analysis to data collected from week beginning July 2nd, 2001 (week 27 in the time plot). Since no child was hospitalized the week before, we can assume that the susceptible population at this time period is the population of children aged < 2 in the region of Valencia.

It is important to emphasize here that the interest when simulating the effect of vaccination strategies may be to study the decrease in disease incidence. In this case study, the available data refer to hospitalizations. Let i_t and y_t be, respectively, the number of infections and hospitalizations at time t . It is reasonable to assume the following relationship:

$$y_t \sim \text{Bin}(i_t, \rho)$$

where ρ is the probability of being hospitalized for RSV infection. Because information regarding the number of newly infected children per week is not available, it is not possible to make a statistical robust estimate of ρ . In Spain, the percentage of children who require hospitalization for RSV is around 0.5% and 2% of the number of infected children (Contreras, 2016; Parra et al., 2013). This percentage coincides with the results obtained in Acedo et al. (2010). Hence, if the interest relies on analysing the number of infections, we can assume that the number of infected children at week t ($t = 1, 2, \dots, T = 208$) is given by the number of hospitalized children divided by the

hospitalization rate:

$$i_t = y_t/h$$

with $h = 0.02$ as proposed in Acedo et al. (2010).

3. Model formulation

3.1. Model formulation without vaccination

In this section we describe a Bayesian stochastic susceptible-infected-recovered-susceptible (SIRS) model in discrete time that was proposed by Corberán-Vallet and Santonja (2014) to study infectious disease dynamics. Let i_t denote the number of infected children at week t , $t = 1, 2, \dots, T$. Because the population of children aged < 2 years in the region of Valencia is finite, the observations are assumed to be Binomial distributed:

$$i_t \sim \text{Bin}(S_{t-1}, p_t) \quad (1)$$

where S_{t-1} represents the susceptible population at time $t - 1$; that is, the number of individuals not yet infected with the disease at time $t - 1$; and p_t is the probability of becoming infected at time t .

In this discrete-time model, the number of individuals in each compartment is examined at discrete time steps. Using a fixed population, the number of susceptible (S), infected (I), and recovered (R) individuals at time t are updated through the following recursive equations:

$$\begin{aligned} S_t &= S_{t-1} - i_t + bR_{t-1} + n_t - \frac{S_{t-1}}{N}n_t \\ I_t &= I_{t-1} - aI_{t-1} + i_t - \frac{I_{t-1}}{N}n_t \\ R_t &= R_{t-1} - bR_{t-1} + aI_{t-1} - \frac{R_{t-1}}{N}n_t \end{aligned} \quad (2)$$

where a is the proportion of infected individuals that recover per unit time; b is the proportion of recovered individuals who lose their immunity and become susceptible again per unit time; n_t is the number of births at time t ; and N is the constant population size. Taking into account that the average time to recover from RSV illness is 10 days and the average time to lose immunity is 200 days, we can set $a = \frac{7 \text{ days (one week)}}{10 \text{ days (recover time)}} = 0.7$ and $b = \frac{7 \text{ days (one week)}}{200 \text{ days (time to lose immunity)}} = 0.035$ (Acedo et al., 2010). Because the recovery time and time to lose immunity for RSV are well-known, we have considered these values as deterministic inputs. Otherwise, these quantities should be considered as additional parameters of the model with their corresponding prior distribution. In addition, using demographic data from the Spanish National Institute of Statistics (<http://www.ine.es>),

the average weekly number of births in the region of Valencia for years 2001–2004 and the population size can be set $n_t = 879$ and $N = 83,205$. The flowchart diagram for the model is described in Figure 2.

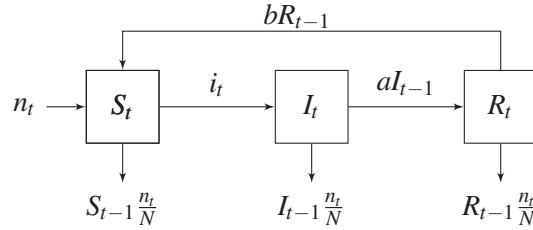

Figure 2: Flowchart of the SIRS model without vaccination. Boxes represent compartments and arrows represent transitions between compartments, labelled by the parameters of the model.

The probability p_t was modelled as:

$$p_t = \min \left\{ \frac{i_{t-1}^\alpha \exp \{r_t\}}{1 + i_{t-1}^\alpha \exp \{r_t\}} + c, 1 \right\} \tag{3}$$

where the mixing parameter α allows for heterogeneous mixing (homogeneous mixing corresponds to $\alpha = 1$ (Bjørnstad, Finkenstädt and Grenfell, 2002); c represents a constant probability of becoming infected and so it accounts for the occurrence of new cases after the disease has faded out; and $\exp \{r_t\}$ represents the time-varying transmission rate. To accommodate the seasonal pattern observed in the dynamics of RSV, this transmission rate is modelled by means of sine-cosine waves as:

$$r_t = a_0 + \sum_{k=1}^K \left[a_{2k-1} \sin \left(\frac{2k\pi t}{52} \right) + a_{2k} \cos \left(\frac{2k\pi t}{52} \right) \right] + \epsilon_t \tag{4}$$

where ϵ_t is a random effect that represents unspecified features of week t . Note that this formulation ensures that the probability lies in the interval 0–1 and it also takes into account the transmissible nature of the infection. The value of K depends on the data under study and it is set as the highest value k^* so that the corresponding parameters a_{2k^*-1} and a_{2k^*} are significant.

The parameters of the model are α , c , $\{a_k\}_{k=0}^{2K}$, and $\{\epsilon_t\}_{t=1}^T$. The prior distribution assumed for parameter α is the Uniform distribution in the interval 0–1. The Uniform distribution in the interval 0–0.01 is assigned to parameter c . In this case study, this range of variation for c is enough to capture the probability of infection the first week of epidemic periods. However, a wider range may be necessary in the analysis of different diseases. Parameters $\{a_k\}$ are assumed to have zero mean Gaussian distributions with standard deviations σ_{a_k} ; and $\{\epsilon_t\}$ are Gaussian distributed random effects with zero mean and standard deviations σ_ϵ . All the standard deviations in the previous equations are assigned the Uniform distribution in the interval 0–5 (Gelman, 2006).

3.2. Model formulation with vaccination

We propose here an extension of the model previously described to accommodate a vaccination strategy that consists on vaccinating a proportion of newborns. As mentioned in the introduction section, the planning of effective vaccine strategies to protect infants from birth to six months are needed. Let \tilde{i}_t be the number of infected children at time t after implementation of the vaccination program for infants. It is important to emphasize that in this section we are working with a hypothetical scenario (since there is not a RSV vaccination strategy implemented in the Community of Valencia), and so data corresponding to the number of new infections are not available. Let \tilde{S}_{t-1} represent the susceptible population at time $t - 1$ and \tilde{p}_t the new probability of becoming infected at time t after introducing the RSV vaccine. We can assume then that:

$$\tilde{i}_t = \tilde{S}_{t-1}\tilde{p}_t \tag{5}$$

The number of individuals in each compartment is updated through the following recursive equations:

$$\begin{aligned} \tilde{S}_t &= \tilde{S}_{t-1} - \tilde{i}_t + b\tilde{R}_{t-1} + (1 - \nu)n_t - \frac{\tilde{S}_{t-1}}{N}n_t \\ \tilde{I}_t &= \tilde{I}_{t-1} - a\tilde{I}_{t-1} + \tilde{i}_t - \frac{\tilde{I}_{t-1}}{N}n_t \\ \tilde{R}_t &= \tilde{R}_{t-1} - b\tilde{R}_{t-1} + a\tilde{I}_{t-1} - \frac{\tilde{R}_{t-1}}{N}n_t \\ \tilde{V}_t &= \tilde{V}_{t-1} + \nu n_t - \frac{\tilde{V}_{t-1}}{N}n_t \end{aligned} \tag{6}$$

Similar to Equations (2), a is the proportion of infected individuals that recover per unit time; b is the proportion of recovered individuals who lose their immunity per unit time; n_t is the number of births at time t ; and N is the constant population size. Parameter ν represents the proportion of newborns that are vaccinated. We assume here that infants receive additional booster doses if necessary to induce optimal levels of RSV neutralizing antibody, and so vaccinated children do not evolve to the susceptible population. Based on this assumption, there is not transition between the vaccinated subpopulation (V) and the susceptible one (S). The flowchart diagram for the model with vaccination is described in Figure 3.

To estimate \tilde{i}_t we need to know the value of \tilde{S}_{t-1} and \tilde{p}_t . The first term is derived by applying the previous recursive equations and the probability \tilde{p}_t can be estimated using the expression:

$$\tilde{p}_t = \min \left\{ \frac{\tilde{i}_{t-1}^{\alpha^*} \exp\{r_t^*\}}{1 + \tilde{i}_{t-1}^{\alpha^*} \exp\{r_t^*\}} + c^*, 1 \right\} \tag{7}$$

where α^* , c^* , and $\{r_t^*\}$ represent the posterior mean estimates obtained when the model without vaccination is fitted to real data. Note that these parameters represent features of RSV dynamics that do not depend on the number of infected children, and so it is sensible to use these estimates to calculate \tilde{p}_t . Varying the value of ν , it is possible to find out the effect of this vaccination strategy on the number of RSV infections.

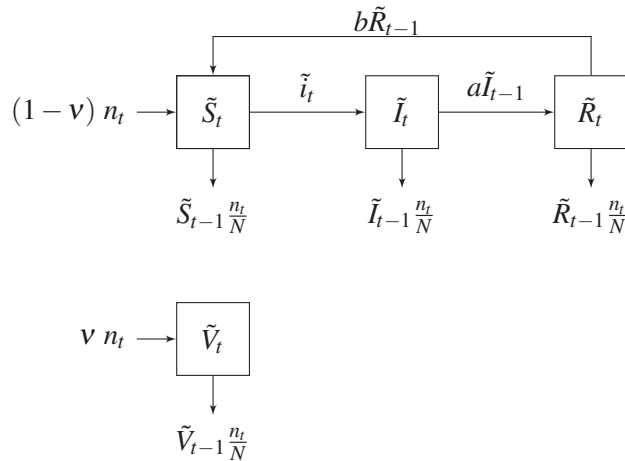

Figure 3: Flowchart of the SIRS model with vaccination (vaccinated children do not evolve to the susceptible population). Boxes represent compartments and arrows represent transitions between compartments, labelled by the parameters of the model.

If booster doses are not planned, vaccinated children may evolve to the susceptible population after an immunization period. In that case, the recursive equations would be replaced by:

$$\begin{aligned}
 \tilde{S}_t &= \tilde{S}_{t-1} - \tilde{i}_t + b\tilde{R}_{t-1} + b^*\tilde{V}_{t-1} + (1 - \nu)n_t - \frac{\tilde{S}_{t-1}}{N}n_t \\
 \tilde{I}_t &= \tilde{I}_{t-1} - a\tilde{I}_{t-1} + \tilde{i}_t - \frac{\tilde{I}_{t-1}}{N}n_t \\
 \tilde{R}_t &= \tilde{R}_{t-1} - b\tilde{R}_{t-1} + a\tilde{I}_{t-1} - \frac{\tilde{R}_{t-1}}{N}n_t \\
 \tilde{V}_t &= \tilde{V}_{t-1} - b^*\tilde{V}_{t-1} + \nu n_t - \frac{\tilde{V}_{t-1}}{N}n_t
 \end{aligned} \tag{8}$$

where b^* represents the proportion of vaccinated children who lose their immunity and become susceptible per unit time. In Acedo et al. (2010), the authors assumed an immunization period by vaccination equal to the immunization after infection. Taking into account this consideration, a value of b^* equal to 0.035 could be assumed. The flowchart diagram for this new scenario is presented in Figure 4.

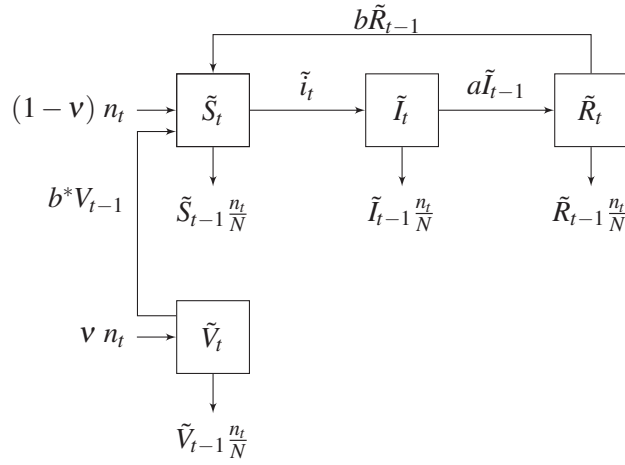

Figure 4: Flowchart of the SIRS model with vaccination (vaccinated children may evolve to the susceptible population after an immunization period). Boxes represent compartments and arrows represent transitions between compartments, labelled by the parameters of the model.

It is important to mention that the previously proposed model is also valid for a maternal vaccination strategy. In that case, ν would represent the proportion of newborns whose mothers have been vaccinated and so they are protected from RSV. Since this maternal immunization strategy does not provide complete protection, children in the V compartment will evolve to the susceptible population after 4–6 months (Higgings et al., 2016). The recursive equations given by (8) should then be used, with parameter b^* adapted to this immunization period.

4. Results

In this section we describe the main results obtained in the analysis of RSV data. We first show the results when the model without vaccines is fitted to the data. The Bayesian analysis of the model allows us to calculate the posterior distribution of the model parameters. Because this posterior distribution is not analytically tractable, we approached it by simulation. In particular, we obtained a random sample from it using Markov chain Monte Carlo (MCMC) simulation techniques as implemented in the free statistical software WinBUGS (Lunn et al., 2000). We fixed a burn-in period of 150000 iterations to assess the convergence of MCMC chains. To reduce the correlation for the samples, we kept one posterior sample in 25 iterations after the burn-in period until a set of 5000 iterations was obtained.

Similar to the study in Corberán-Vallet and Santonja (2014), we model directly the weekly number of RSV hospitalizations as $y_t \sim Bi(S_{t-1}, p_t)$, and so p_t represents the probability of being hospitalized at time t . The posterior mean and 95% credible intervals are displayed in Figure 5.

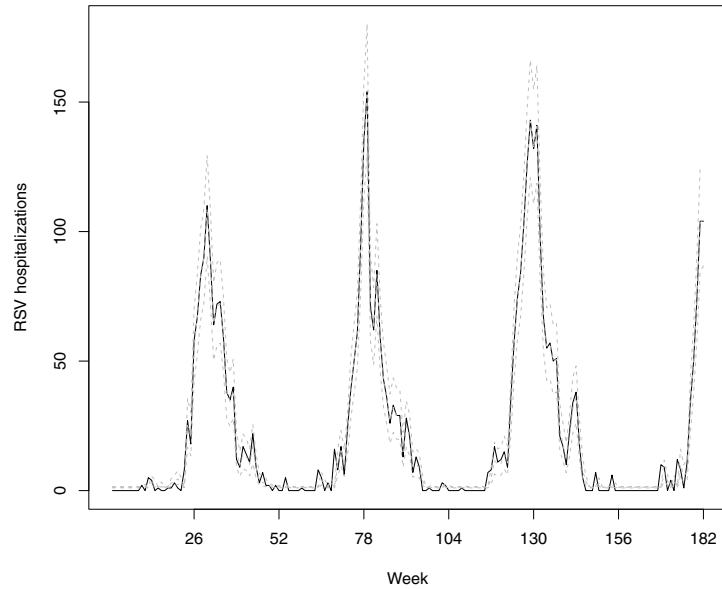

Figure 5: Hospitalizations for RSV (solid black line) together with posterior means and 95% credible intervals (dotted gray lines) from week beginning July 2nd 2001 to week beginning December 20th 2004 in the Spanish region of Valencia.

Figure 6 shows the estimated transmission rate $\exp\{r_t\}$ together with its seasonal component, which is defined by the sum of two harmonic waves ($K = 2$; higher-order frequencies were no significant). As can be seen, even though seasonality plays an important role in disease transmission, adding random effects in the transmission rate model to account for overdispersion is fundamental to provide a more realistic description of the transmission pattern.

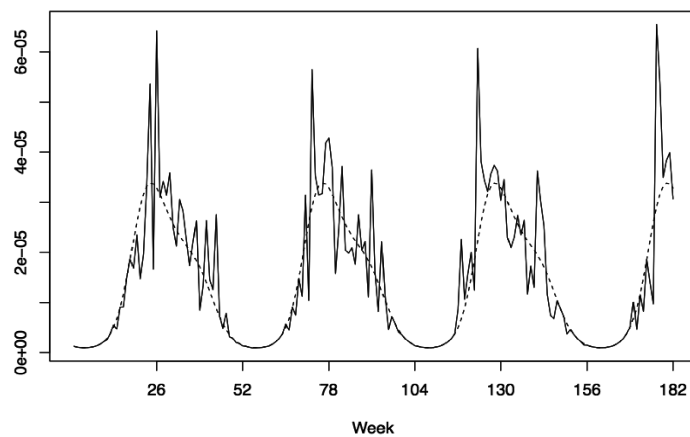

Figure 6: Estimated transmission rate together with its seasonal component from week beginning July 2nd 2001 to week beginning December 20th 2004.

Table 1: Posterior means and 95% credible intervals for the parameters of the model.

Parameter	Mean	Credible interval
α	0.80	(0.66,0.95)
c	1.54e-05	(1.26e-05,1.84e-05)
a_0	-11.73	(-12.28,-11.26)
a_1	-0.61	(-0.94,-0.30)
a_2	-1.55	(-2.11,-1.06)
a_3	-0.44	(-0.73,-0.17)
a_4	-0.14	(-0.42,0.10)

It is important to mention that these results are very similar to the ones presented in Corberán-Vallet and Santonja (2014). The main difference is that here we are not interested in prediction, and so we do not keep the last weeks to measure the out-of-sample forecast accuracy. Because the data set is not exactly the same, some minor differences are observed in the posterior distribution of the model parameters. The posterior mean and 95% credible intervals for the parameters of the model are shown in Table 1.

Once the posterior means of the parameters of the model without vaccines have been estimated, we can analyse the effect of the newborn vaccination strategy. As explained in Section 3.2, parameters α , c , and $\{r_t\}$ represent features of RSV dynamics that do not depend on the number of infected children, and they are used to compute both the new probability of hospitalization once the vaccine has been implemented and the new number of infections. In our simulation of the vaccine implementation, we assume that there were no vaccinations before July 2nd 2001; that is, vaccines are introduced the first week of our time frame and so we set $V_0 = 0$.

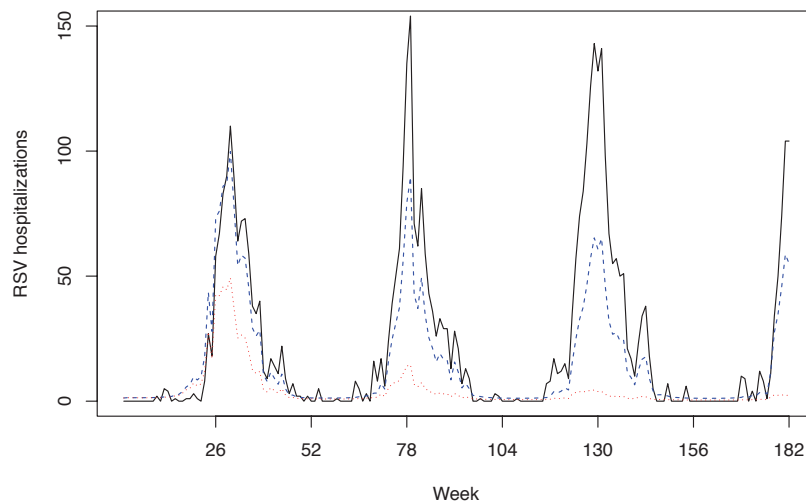

Figure 7: Number of real hospitalizations for RSV (solid line) and simulated numbers of hospitalizations for two different coverage rates (percentages of vaccinated newborns), $\nu = 0.2$ (dashed line) and $\nu = 0.8$ (dotted line).

Figure 7 shows the real number of hospitalizations from week beginning July 2nd 2001 to week beginning December 20th 2004 and the simulated numbers for two different values of ν : $\nu = 0.2$ and $\nu = 0.8$. As expected, the number of RSV hospitalizations decreases as the percentage of vaccinated newborns increases. Note that the value of ν is decided by policymakers and we just set these values as an example.

Taking into account an average of 6.28 hospitalization days for every infected child and €500 per day and child hospitalized (Acedo et al., 2010), we can estimate the total cost of hospitalizations for the time period of study. If no child is vaccinated, the cost of hospitalizations is approximately €13,213,120. This quantity decreases as ν increases. The hospitalization cost for a value of ν equal to 0.2 would be around 8.5 millions of euros, and if we set $\nu = 0.8$, 2.5 millions of euros. Note that in order to complete the economic analysis, we should also consider the vaccine price. For instance, (Acedo et al., 2010) assumed a cost of €300 per child.

4.1. Comparison with a deterministic continuous-time model

In Corberán-Vallet and Santonja (2014), the authors compared the model described in Section 3.1 with four alternative formulations of the SIRS model in discrete time: a stochastic model with a deterministic seasonal transmission rate, a stochastic model where the transmission rate was assumed to be constant over time, and the equivalent deterministic formulations. The results showed that the proposed Bayesian SIRS model in discrete-time lead to an improved goodness of fit. We compare here the results obtained with our model with those provided by a deterministic continuous-time formulation similar to the one implemented in Acedo et al. (2010). As mentioned in the Introduction, deterministic compartmental models in continuous-time are widely used to assess the effect of vaccination programs. By considering only one age-group and a constant population size, the deterministic continuous-time model without vaccines can be formulated as:

$$\begin{aligned}\frac{dS}{dt} &= -\beta(t)SI + bR + \mu - \mu S \\ \frac{dI}{dt} &= -aI + \beta(t)SI - \mu I \\ \frac{dR}{dt} &= -bR + aI - \mu R\end{aligned}\tag{9}$$

where $\beta(t)$ is defined as $b_0 + b_1 \cos(2\pi t + \psi)$ to account for seasonality. The flowchart of this model is shown in Figure 8.

Similar to Acedo et al. (2010), we have assumed that 1% of infants are infected in January 1999 while the remaining 99% of infants are susceptible. We have also set $\mu = 0.01074$, $b = 1.59$, and $a = 36.5$. In order to estimate parameters b_0 , b_1 and ψ , we have used the `dsolve` package (Soetaert, Petzoldt and Setzer, 2010) in R (R Core Team, 2017) together with the `optim` function.

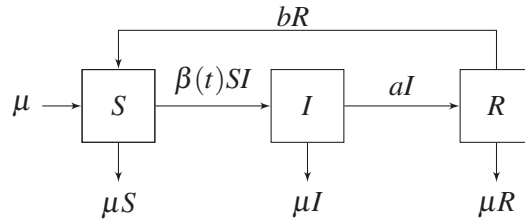

Figure 8: Flowchart of the deterministic continuous-time SIRS model without vaccination.

Figure 9 compares the estimates of RSV hospitalizations obtained with both the Bayesian stochastic SIRS model in discrete-time and its deterministic counterpart. As can be seen, the deterministic continuous-time approach is not able to properly describe epidemic peaks. The seasonal pattern is constant over time and it does not explain particular features of annual epidemics. The fitting RMSE are, respectively, 2.52 and 19.09. These results highlight the importance of taking into account the stochasticity inherent in the transmission dynamics.

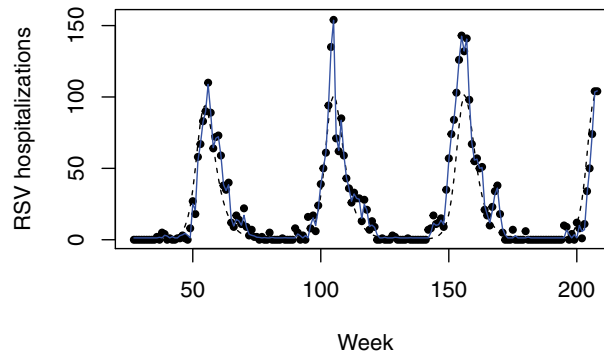

Figure 9: Real hospitalizations for RSV (solid points) and the estimates obtained with both the Bayesian stochastic model in discrete-time (solid line) and the deterministic continuous-time model (dashed line).

If we assume that a proportion of newborns are vaccinated, the deterministic model can be reformulated as:

$$\begin{aligned}
 \frac{dS}{dt} &= -\beta(t)SI + bR + (1 - \nu)\mu - \mu S \\
 \frac{dI}{dt} &= -aI + \beta(t)SI - \mu I \\
 \frac{dR}{dt} &= -bR + aI - \mu R \\
 \frac{dV}{dt} &= \nu\mu - \mu V
 \end{aligned}
 \tag{10}$$

Figure 10 displays the real number of hospitalizations from week beginning July 2nd 2001 to week beginning December 20th 2004 and the numbers simulated by the deterministic continuous-time model for a coverage rate $\nu = 0.2$. For comparative purposes, we have also included the results provided by our model. As expected, the deterministic model does not explain properly epidemic peaks. Nevertheless, we can conclude that both strategies show a similar decreasing trend in the number of RSV hospitalizations after the introduction of the vaccine.

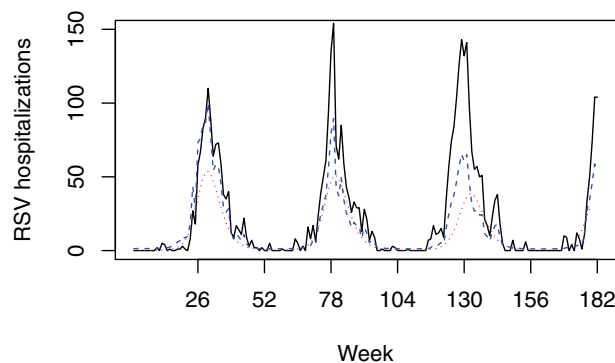

Figure 10: Real hospitalizations for RSV (solid line) and simulated numbers of hospitalizations provided by both the Bayesian stochastic SIRS model (dashed line) and the deterministic continuous-time model (dotted line) for a coverage rate $\nu = 0.2$.

5. Conclusion

In this paper, we have described a stochastic compartmental model in discrete-time to describe RSV dynamics in the region of Valencia. However, the model can be adapted for other infectious diseases with (or without) a seasonal pattern and temporary (or permanent) immunity, replacing the transmission rate and the immunity rate according to the nature of disease. Unlike standard formulations, this compartmental model does not assume mass-action mixing of individuals in the population. In addition, the model considers the stochasticity inherent in the transmission of disease and, consequently, it provides a more realistic and accurate description of the progression of infections.

The extended model proposed in this paper provides a useful framework to address one of the important needs in RSV incidence control: the implementation of an efficient vaccination strategy. In particular, we have studied the effects of a vaccination strategy that consists on vaccinating a proportion of newborns, which are the highest priority target population. Additionally, we have pointed out how to adapt the model to simulate a vaccination strategy targeted to pregnant women.

Nevertheless, the model has some limitations. We have assumed that the number of births equals the number of deaths so that the total population size is constant. In

addition, we do not consider an age structure into the formulation of the compartmental model. It would be valuable to extend the proposed model to allow for different age groups, for instance infants < 6 months of age and children ≥ 6 months of age, which are considered as distinct target populations for RSV vaccines. An age-structured model would provide an important tool to study the effects of alternative vaccination strategies. It could demonstrate how immunization of a target population may protect others. Besides, this formulation could be used to simulate the benefits of implementing a maternal vaccination strategy followed by direct older infant vaccination as maternal antibody wanes.

Note that we have only implemented a control strategy based on vaccination. However there are other possibilities such as isolation of infected individuals. This alternative control strategy could be straightforwardly incorporated into the model by adapting the probability of becoming infected. Under this scenario, the probability of infection at a particular time point would depend only on a proportion of infected individuals at the previous time point (the ones that have not been isolated). It would also be interesting to assess the impact of both control strategies simultaneously.

Another very fruitful area for further research is the extension of the proposed model to the spatial domain. Space can play a significant role in RSV transmission. In addition, a spatio-temporal model may be useful to detect high-risk areas in need of more strong intervention strategies to reduce the burden of disease.

Finally, it is worth emphasizing that we have focused here on models that have been previously proposed to analyse the impact of vaccination strategies; in particular, we have focused on compartmental models. However, the literature on models for the analysis of infectious disease data is vast and can be found in both statistical as well as epidemiological journals. Comprehensive coverage of statistical models for the analysis of infectious diseases in a single paper is not possible and it is beyond the scope of this paper. Nevertheless, it would be interesting to extend common approaches to model count time series (such as INAR models (Rao and McCabe, 2016) or p-splines (Eilers, Marx and Durban, 2016)) to incorporate the impact of vaccination programs and compare the performance of these different approaches.

Acknowledgement

This work has been supported by Grant Number MTM2014-56233-P from the Spanish Ministry of Economy and Competitiveness.

References

- Acedo, L., Díez-Domingo, J., Morano, J.A. and Villanueva, R.J. (2010). Mathematical modelling of respiratory syncytial virus (RSV): vaccination strategies and budget applications. *Epidemiology and Infection*, 138, 853–860.

- Allen, L.J. (2008). An introduction to stochastic epidemic models. In Brauer, F., van den Driessche, P. and Wu, J. (Eds.) *Mathematical Epidemiology*. Springer, Berlin.
- Anderson, L.J., Dormitzer, P.R., Nokes, D.J. Rappuoli, R. Roca, A. and Graham, B.S. (2013). Strategic priorities for respiratory syncytial virus (RSV) vaccine development. *Vaccine*, 31S, B209–B215.
- Beeler, J.A. and Eichelberger, M.C. (2013). Influenza and respiratory syncytial virus (RSV) vaccines for infants: safety, immunogenicity, and efficacy. *Microbial Pathogenesis*, 55, 9–15.
- Bjørnstad, O.T., Finkenstädt, B.F. and Grenfell, B.T. (2002). Dynamics of measles epidemics: estimating scaling of transmission rates using a time series SIR model. *Ecological Monographs*, 72, 169–184.
- Boys, R.J. and Giles, P.R. (2007). Bayesian inference for stochastic epidemic models with time-inhomogeneous removal rates. *Journal of Mathematical Biology*, 55, 223–247.
- Brauer, F. (2008). Compartmental models in epidemiology. In Brauer, F., van den Driessche, P. and Wu, J. (Eds.) *Mathematical Epidemiology*. Springer, Berlin.
- Christensen, H., Hickmana, M., Edmunds, W.J. and Trotter, C.L. (2013). Introducing vaccination against serogroup B meningococcal disease: an economic and mathematical modelling study of potential impact. *Vaccine*, 31, 2638–2646.
- Contreras, J.R. Vacuna contra el Virus Respiratorio Sincitial (VRS). Asociación Española de Vacunología. Informe Técnico <http://www.vacunas.org/vacuna-contra-el-virus-respiratorio-sincitial-vrs/> [In Spanish. Accessed in: 26th July 2016].
- Corberán-Vallet, A. and Santonja, F.J. (2014). A Bayesian SIRS model for the analysis of respiratory syncytial virus in the region of Valencia, Spain. *Biometrical Journal*, 56, 808–818.
- Craig, A.P., Hanger, J., Loader, J., Ellis, W.A.H., Callaghan, J., Dexter, A., Jones, D., Beagley, K.W., Timms, P. and Wilson, D.P. (2014). A 5-year Chlamydia vaccination programme could reverse disease-related koala population decline: predictions from a mathematical model using field data. *Vaccine*, 32, 4163–4170.
- Dudas, R.A. and Karron, R.A. (1998). Respiratory syncytial virus vaccines. *Clinical Microbiology Reviews*, 11, 430–439.
- Eilers, P.H.C., Marx, B.D. and Durban, M. (2015). Twenty years of P-splines. *SORT-Statistics and Operations Research Transactions*, 39, 149–186.
- Gelman, A. (2006). Prior distributions for variance parameters in hierarchical models. *Bayesian Analysis*, 1, 515–533.
- Gibson, G.J. and Renshaw, E. (1998). Estimating parameters in stochastic compartmental models using Markov chain methods. *IMA Journal of Mathematics Applied in Medicine and Biology*, 15, 19–40.
- Higgins, D., Trujillo, C. and Keech, C. (2016). Advances in RSV vaccine research and development - a global agenda. *Vaccine*, 34, 2870–2875.
- Hogan, A.B., Glass, K., Moore, H.C. and Anderssen, R.S. (2016). Exploring the dynamics of respiratory syncytial virus (RSV) transmission in children. *Theoretical Population Biology*, 110, 78–85.
- Jones, B.G., Sealy, R.E., Surman, S.L., Portner, A., Russell, C.J., Slobod, K.S., Dormitzer, P.R., DeVincenzo, J. and Hurwitz, J.L. (2014) Sendai virus-based RSV vaccine protects against RSV challenge in an in vivo maternal antibody model. *Vaccine*, 32, 3264–3273.
- Lunn, D.J., Thomas, A., Best, N. and Spiegelhalter, D. (2000). WinBUGS — a Bayesian modelling framework: concepts, structure, and extensibility. *Statistics and Computing*, 10, 325–337.
- Ma, Z. and Li, J. (2009). *Dynamical Modelling and Analysis of Epidemics*. World Scientific, London.
- O’Neill, P.D. (2002). A tutorial introduction to Bayesian inference for stochastic epidemic models using Markov chain Monte Carlo methods. *Mathematical Biosciences*, 180, 103–114.
- Parra, A., Jiménez, C., Hernández, S., García J.E. and Cardona, A.M. (2013). Bronquiolitis: artículo de revisión. *Neumología Pediátrica*, 8, 95–101.

- Pérez-Breva, L., Villanueva R.J., Villanueva-Oller, J., Acedo L., Santonja F.J., et al. (2014). Optimizing strategies for meningococcal C disease vaccination in Valencia (Spain). *BMC Infectious Diseases*, 14, 280.
- Poletti, P., Merler, S., Ajelli, M., Manfredi, P., Munywoki, P.K., Nokes, D.J. and Melegaro, A. (2015). Evaluating vaccination strategies for reducing infant respiratory syncytial virus infection in low-income settings. *BMC Medicine*, 13–49.
- R Development Core Team (2017). R: A language and environment for statistical computing. R Foundation for Statistical Computing, Vienna, Austria. ISBN 3-900051-07-0, <http://www.R-project.org>.
- Rao, Y. and McCabe, B. (2016). Real-time surveillance for abnormal events: the case of influenza outbreaks. *Statistics in Medicine*, 35, 2206–2220.
- Roberts, J.N., Graham, B.S., Karron, R.A., Munoz, F.M., Falsey, A.R., Anderson, L.J., Marshall, V. Kim, S. and Beeler, J.A. (2016). Challenges and opportunities in RSV vaccine development: meeting report from FDA/NIH workshop. *Vaccine*, 34, 4843–4849.
- Soetaert, K., Petzoldt, T. and Setzer, R.W. (2010). Solving differential equations in R: Package deSolve. *Journal of Statistical Software*, 33, 1–25.
- Van Hoek, A.J., Melegarob, A., Zaghenid, E., Edmundsa, W.J. and Gayb, N. (2011). Modelling the impact of a combined varicella and zoster vaccination programme on the epidemiology of varicella zoster virus in England. *Vaccine*, 29, 2411–2420.
- Vannia, T., Mendes, P., Fossa, A., Mesa-Friasa, M. and Legooda, R. (2012). Economic modelling assessment of the HPV quadrivalent vaccine in Brazil: a dynamic individual-based approach. *Vaccine*, 30, 4866–4871.
- Weidemann, F., Dehnert, M., Koch, J., Wichmann, O. and Höhle, M. (2014). Modelling the epidemiological impact of rotavirus vaccination in Germany – A Bayesian approach. *Vaccine*, 32, 5250–5257.
- World Health Organization. *Using the Results of Modelling to Inform WHO Guidelines*. http://www.who.int/kms/modelling_whoguidelines_2016/en/
- Yu, Z., Liu, J., Wang, X., Zhu, X., Wang, D. and Han, G. (2016). Efficient vaccine distribution based on a hybrid compartmental model. *PLoS One*, 11, e0155416.

