

Journal of Siberian Federal University. Engineering & Technologies, 2017, 10(5), 682-690

~ ~ ~

УДК 629

Mathematical Model for Calculation of Oscillations in the Main Bearing Frame of Railcar with Changing Stiffness and Physical Parameters

Ziyoda Mukhamedova*

*Tashkent Institute of Railway Transport Engineers
1 Adylkhodjaeva Str., Tashkent, 100167, Uzbekistan*

Received 06.06.2016, received in revised form 10.12.2016, accepted 13.02.2017

This article covers the use of analytical technique of solutions for flexural and longitudinal oscillations of the bearing framework of a railcar body frame in the form of an elastic core of variable section with a variable weight, flexural and longitudinal rigidity. The calculation is performed for the modernization of the body frame of emergency and repair rail service car, taking into account the variability of section, mass, longitudinal and bending stiffness along the length to prolong the service life of their useful operation.

Keywords: railcar, main frame of the body, analytical-numerical method, reliability, strength.

Citation: Mukhamedova Z. Mathematical model for calculation of oscillations in the main bearing frame of railcar with changing stiffness and physical parameters, J. Sib. Fed. Univ. Eng. technol., 2017, 10(5), 682-690. DOI: 10.17516/1999-494X-2017-10-5-682-690.

© Siberian Federal University. All rights reserved

* Corresponding author E-mail address: ziyoda.mukhamedova@email.com

Численная модель колебаний несущего каркаса рамы кузова аварийно-восстановительной автотрисы с переменными жесткостными и массовыми параметрами

З. Мухамедова

*Ташкентский институт инженеров
железнодорожного транспорта
Узбекистан, 100167, Ташкент, ул. Адылходжаева, 1*

В данной статье представлен алгоритм расчета для моделирования напряженно-деформированного состояния несущего каркаса рамы кузова аварийно-восстановительной автотрисы; приведены результаты численного исследования по напряженно-деформированному состоянию несущего каркаса рамы кузова аварийно-восстановительной автотрисы с учетом переменности сечения, массы, изгибной и продольной жесткости по её длине; дается обоснование выбора диагностических параметров для оценки динамической прочности, надежности и прогнозируемого ресурса работы несущего каркаса рамы кузова аварийно-восстановительной автотрисы.

Ключевые слова: автотриса, каркас рамы кузова, аналитико-численный метод, надежность, прочность.

1. Introduction

In conditions of global financial and economic crisis the issues of increasing the reliability of operational railway equipment by upgrading the individual structural assemblies during capital repair with the prolongation of its useful life, are relevant. At that, even welded, according to the norms of depot repair, cracks continue to develop and grow in size, weakening the most dangerous sections. It is obvious that the general stress state of body frame, spring suspension and running gear of the rolling stock will significantly depend on the initial bending of neutral axis and permanent dynamic forces. These factors cause a 1.2–1.5 times decrease in total life of railcars (rail service car). In modern foreign patent and scientific literature the problems of increasing the reliability and strength of the frames, load-bearing body structure and components for rail vehicles during their design, operation and modernization are extensively studied [1, 2]. We offer an analytical-numerical method based on the dynamic strength of the bearing body frame of emergency and repair rail service car, assuming a beam-type pattern of its fluctuations with elastic fixing of the ends under harmonic load as it moves along the track with periodic joint roughness.

The main objectives of the creation of new designs of mechanical body components, running gear, spring suspension systems of rail service cars, as well as of modernization of existing ones are to expand the functionality, to increase the reliability, strength and durability. The issues of research and improvement of equivalent bearing body of the cars and their spring suspension have appeared simultaneously with the beginning of their use, for example with the advent of motor cars or railway transport vehicles. An analysis of researches in the field of optimization of dynamic characteristics of a special self-propelled rolling stock, with the development of methods of mathematical modeling and numerical analysis, revealed that since the 1960s, a great number of works that dealt with the

dynamics of the rolling stock in plane statement and since 1980's the papers have been published on spatial oscillations of locomotives and railcars when driving along straight and curved sections of the track [3, 4]. Consider some of the works which use the method of optimal design based on the use of mathematical models (including computerized ones) with the dynamic quality criteria.

In works by V.A. Kamaev [5] the mathematical models of running parts of railway vehicles are considered, taking into account wheel and rail interaction, a comparative analysis of algorithms and optimization methods are given and the ways to reduce computer time are recommended to solve an optimization problem. Analytical optimization methods in [4] are used only for quasi-linear systems for which an integral expression of optimization criterion could be explicitly written. In general, the principles of optimization are not widespread and hardly ever used in construction of running parts of rail service cars. This greatly explains the lack of sophisticated optimization programs for comparatively simple mathematical models and the lack of methodological principles of optimization with the use of complex mathematical and physical models, and in some cases the lack of correct mathematical models of the process.

Turning to the previous studies on this subject area, similar researches with focus on mathematical modelling for repair of defective rail wheels was conducted by researchers from Vilnius Gediminas Technical University, Marijonas Bogdevicius, Rasa Zygiene, Bureika Gintautas and Rimantas Subačius. The research conducted by first two researchers allowed to construct mathematical models for assessing the impact of the uneven railroads and other elements on the structures of the rail car, especially wheels [6]. Whereas, Bureika and Subačius concentrated on mathematical models for calculating bending tensions noted in various elements of the rail car [7]. Moreover, numerical modelling by Ioan Sebesan and Dan Baiasu covered the impact of yawing oscillations on body, bogie and wheel elements and allowed for passenger car to be used regularly at the speed of 160 km per hour. As can be noted from these researches, the current article provides similar approach with focus on mathematical modelling of fluctuations in main bearing frame of railcar rather than wheels [8].

This article provides a calculation algorithm for the simulation of stress-strain state of load-bearing body frame of emergency and repair rail service car; it gives the results of numerical studies on stress-strain state of bearing body frame structure of emergency and repair rail service car taking into account the variability of section, mass, longitudinal and bending stiffness along its length; it outlines the validity for the choice of diagnostic parameters for the evaluation of dynamic strength, reliability and predictable service life of bearing body frame structure of emergency and repair rail service cars.

Equivalent bearing body frame of emergency and repair rail service car was simulated by an elastic rod with variable cross section, with variable mass, bending and longitudinal stiffness. The difference between the proposed model and the existing ones [1, 2] is an account of the variability of cross section, mass, and the longitudinal and bending stiffness along the length of equivalent beam, which corresponds to the actual conditions of operation. In existing methods of calculation a beam of uniform strength is considered for the simplification, or an approximate calculation is carried out on the model with lumped parameters, excluding elasticity. These approximate models in dynamics may create an error up to 150 – 200 % of the real strains and stresses. Therefore, in practice, pilot studies are always performed and dynamic correction coefficients are introduced into the calculations of strength and stability.

2. Mathematical model of oscillations

For the model proposed here, the parameters of the equivalent load-bearing body frame of the locomotive are taken in the form of variable functions:

- The mass per unit length of the body frame of emergency and repair rail service car (kg/m)

$$m_k(X) = m_o * (a_o + a_1 X + a_2 X^2), \quad (1)$$

- the area of cross section

$$F(X) = F_o * (d_o + d_1 X + d_2 X^2), \quad (2)$$

the length of the main bearing body frame of emergency and repair rail service car is 12.96 meters and the X coordinate varies in the range $0 \leq X \leq 12,96$ m:

- the reduced moment of inertia of frame section on the axis $X_C - I_X$ (cm⁴):

$$I_X(X) = I_o * (b_o + b_1 X + b_2 X^2), \quad (3)$$

where the coefficients $a_o, a_1, a_2, d_o, d_1, d_2, b_o, b_1, b_2$ obtained by approximation with use of spline-functions [3] method on the basis of real data on the linear mass $m_k(X)$, the cross sectional area $F(X)$, given the inertia $I_X(X)$.

- the reduced bending stiffness

$$S_I(X) = E * I_X(X), \quad (4)$$

where $I_X(X)$ is calculated by the formula (3).

The Figure 1 shows the general overview of the elements of the railcar with details of the impact of forces, dimensions and location of the units mentioned in Eqs. (1)–(4).

An assumption is made that the body frame of rail service car is represented in the form of an elastic rod (beam) with constant modulus of material elasticity $E = \mathbf{const}$ and the density $\rho = \mathbf{const}$; it has some static initial radius of deflection R . The equations of bending and longitudinal oscillations for this model are taken by analogy with [9, 10].

To analyze the stress-strain state of equivalent frame of bearing structure of emergency and repair rail service car, the differential equations of bending and longitudinal oscillations of straight rods of variable section are used (considering torsional oscillations relatively small compared to other components) by analogy with [9, 10].

$$\begin{aligned} m_k(X) \frac{\partial^2 U(X,t)}{\partial t^2} - E \frac{\partial F(X)}{\partial X} \cdot \frac{\partial U(X,t)}{\partial X} - EF(X) \frac{\partial^2 U(X,t)}{\partial X^2} = \\ = N_{\pi}(X,t) + E \frac{\partial I_X(X)}{\partial X} \cdot \frac{1}{R^2} + 2EI_X(X) \frac{1}{R} \frac{\partial^3 W(X,t)}{\partial X^3}; \end{aligned} \quad (5)$$

$$\begin{aligned} m_k(X) \frac{\partial^2 W(X,t)}{\partial t^2} + EI_X(X) \frac{\partial^4 W(X,t)}{\partial X^4} + E \frac{\partial^2 I_X(X)}{\partial X^2} \cdot \frac{\partial^2 W(X,t)}{\partial X^2} = \\ = P_A(X,t) + \frac{E}{R} \left[\frac{\partial^2 I_X(X)}{\partial X^2} + 2I_X(X) \cdot \frac{\partial^3 U(X,t)}{\partial X^3} \right]. \end{aligned} \quad (6)$$

After substituting the Eqs. (1)–(4) and their derivatives in the system of differential Eqs. (5)–(6) we obtain the nonlinear equations of the form:

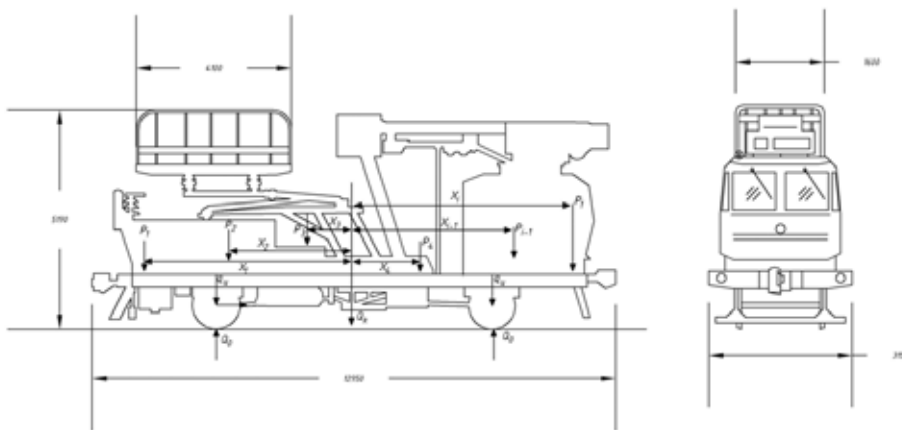

Fig. 1. Design scheme for the equivalent load-bearing frame of the body frame of railcar

$$\begin{aligned} & \left[m_0 \cdot (a_0 + a_1 X + a_2 X^2) \right] \frac{\partial^2 U(X,t)}{\partial t^2} - E [F_0 \cdot (d_1 + 2d_2 X)] \cdot \frac{\partial U(X,t)}{\partial X} \\ & - E [F_0 \cdot (d_0 + d_1 X + d_2 X^2)] \frac{\partial^2 U(X,t)}{\partial X^2} = N_{\mathcal{D}}(X,t) + \end{aligned} \quad (7)$$

$$+ E \cdot [I_0 \cdot (b_1 + 2b_2 X)] \cdot \frac{1}{R^2} + 2E \cdot [I_0 \cdot (b_0 + b_1 X + b_2 X^2)] \cdot \frac{1}{R} \frac{\partial^3 W(X,t)}{\partial X^3};$$

$$\begin{aligned} & \left[m_0 \cdot (a_0 + a_1 X + a_2 X^2) \right] \cdot \frac{\partial^2 W(X,t)}{\partial t^2} + E \cdot [I_0 \cdot (b_0 + b_1 X + b_2 X^2)] \cdot \frac{\partial^4 W(X,t)}{\partial X^4} + \\ & + E \cdot 2b_2 \cdot I_0 \frac{\partial^2 W(X,t)}{\partial X^2} = P_{\mathcal{D}}(X,t) + \frac{E}{R} \cdot \left[2b_2 I_0 + 2 \cdot [I_0 \cdot (b_0 + b_1 X + b_2 X^2)] \cdot \frac{\partial^3 U(X,t)}{\partial X^3} \right]. \end{aligned} \quad (8)$$

Dividing term by term each of the Eqs. of the system (7)–(8) by $m_k(X)$, the entire frame of the body is divided into 120 points (X coordinate varies in the range of $0 \leq X \leq 12,96$ m), for each of the given K -section the coefficients in the Eqs. of the system (7)–(8) are constant and they could be introduced by iteration method (piecewise linear approximation) into computer solution in the procedure similar to the ones in [9–10].

After the introduction of notations, we obtain the Eqs. of the form:

$$\begin{aligned} & \frac{\partial^2 U(X,t)}{\partial t^2} - A_{k1}(X) \cdot \frac{\partial U(X,t)}{\partial X} - B_{k1}(X) \frac{\partial^2 U(X,t)}{\partial X^2} = C_{k1}(X) \cdot \sin n\omega t + \\ & + D_{k1}(X) + E_{k1}(X) \cdot \frac{\partial^3 W(X,t)}{\partial X^3}; \end{aligned} \quad (9)$$

$$\begin{aligned} & \frac{\partial^2 W(X,t)}{\partial t^2} + A_{k2}(X) \cdot \frac{\partial^4 W(X,t)}{\partial X^4} + B_{k2}(X) \cdot \frac{\partial^2 W(X,t)}{\partial X^2} = \\ & = C_{k2}(X) \cdot \cos n\omega t + D_{k2}(X) + E_{k2}(X) \cdot \frac{\partial^3 U(X,t)}{\partial X^3}, \end{aligned} \quad (10)$$

where the following notation are introduced:

- for longitudinal oscillations of the body frame of rail service car – Eq. (9)

$$A_{K1}(X) = \frac{EF_0(d_1 + 2d_2X)}{m_K(X)} ; B_{K1}(X) = \frac{EF_0(d_0 + d_1X + d_2X^2)}{m_K(X)} ;$$

$$C_{K1}(X) = \frac{N_{AK}(X)}{m_K(X)} , N_{AK}(X) = N_{A-n} \sin \frac{(2n-1) \cdot \pi \cdot X}{2\ell_0} .$$

Here the horizontal external dynamic load is taken in the form:

$$N_{AK}(X, t) = N_{A-n} \sin \frac{(2n-1) \cdot \pi \cdot X}{2\ell_0} \cdot \sin n\omega t , \quad (11)$$

where $n = 1, 2, 3, \dots, 5$ – is a number of harmonics, N_{Dn} – is taken according to experimental data obtained, depending on different modes of loading:

$$D_{K1}(X) = \frac{E \cdot (I_0 \cdot (b_1 + 2b_2X))}{m_K(X)} \cdot \frac{1}{R^2} ; E_{K1}(X) = \frac{2E \cdot (I_0 \cdot (b_0 + b_1X + b_2X^2))}{m_K(X)} \cdot \frac{1}{R} ;$$

- for bending (transverse) oscillations of the body frame of rail service car – Eq. (10)

$$A_{K2}(X) = \frac{E \cdot (I_0 \cdot (b_0 + b_1X + b_2X^2))}{m_K(X)} ; B_{K2}(X) = \frac{2E \cdot (I_0 \cdot b_2)}{m_K(X)} ;$$

$$C_{K2}(X) = \frac{P_{AK}(X)}{m_K(X)} , P_{AK}(X) = P_{A-n} \sin \frac{\pi \cdot n \cdot X}{\ell_0} .$$

Here the vertical external dynamic load is taken in the form:

$$P_{AK}(X, t) = P_{A-n} \sin \frac{n \cdot \pi \cdot X}{\ell_0} \cdot \cos n\omega t , \quad (12)$$

where $n = 1, 2, 3, \dots, 5$ – is a number of harmonics, P_{Dn} – is taken according to experimental data obtained, depending on different modes of loading.

$$D_{K2}(X) = \frac{E \cdot (2I_0 \cdot b_2)}{R \cdot m_K(X)} ; E_{K2}(X) = \frac{2E \cdot (I_0 \cdot (b_0 + b_1X + b_2X^2))}{m_K(X)} \cdot \frac{1}{R} .$$

The solution of the system (7)–(8) is performed with the linearization by Simpson’s method, then Fourier method is applied to the differential equations with constant coefficients with further application of operational Laplace transform in time; numerical studies are carried out by the methods of piecewise linear approximation and boundary elements method, similar to the procedures given in [9–10] in *Mathcad 14* programming environment. Initial conditions are taken as zero ones, and the boundary conditions – in the form of elastic fixing of the ends.

Thus, it is possible to find a general solution of differential Eqs. of bending and longitudinal oscillations of the body frame of emergency and repair rail service car (9) and (10) in the form:

$$W(X, t) = \sum_{k=1}^{\infty} W(X) * \left\{ \frac{C_{K2}}{W(X)} \cdot \frac{\cos n\omega t - \cos \lambda_{2n} t}{\lambda_{2n}^2 - (n\omega)^2} + W_0 \cdot \cos \lambda_{2n} t + \right.$$

$$\left. + \left[\frac{D_{K2}}{W(X)} + V_{II} \right] * \frac{1}{\lambda_{2n}} \cdot \sin \lambda_{2n} t \right\} ; \quad (13)$$

$$\begin{aligned}
 U(t) = & \frac{C_{K1}}{U(X)} \cdot \frac{n\omega \cdot \sin \lambda_{1n}t - \lambda_{1n} \sin n\omega t}{n\omega \cdot \lambda_{1n} \cdot (\lambda_{1n}^2 - (n\omega)^2)} + U_0 \cdot \cos \lambda_{1n}t + \\
 & + \left[\frac{D_{K1}}{U(X)} + V_j \right] * \frac{1}{\lambda_{1n}} \cdot \sin \lambda_{1n}t + \frac{\hat{O}(X)}{U(X)} * \left\{ \frac{C_{K2}}{W(X)} * W_1(t) + \right. \\
 & + W_0 \cdot \frac{\cos \lambda_{2n}t - \cos \lambda_{1n}t}{\lambda_{1n}^2 - \lambda_{2n}^2} + \frac{D_{K2}}{W(X)} * \frac{\sin \lambda_{2n}t - \sin \lambda_{1n}t}{\lambda_{1n}^2 - \lambda_{2n}^2} + \\
 & \left. + V_{II} \cdot \frac{\sin \lambda_{2n}t - \sin \lambda_{1n}t}{\lambda_{1n}^2 - \lambda_{2n}^2} \right\},
 \end{aligned}
 \tag{14}$$

where

$$\begin{aligned}
 W_1(t) = & \frac{\cos \lambda_{1n}t}{(\lambda_{1n}^2 - (n\omega)^2) \cdot (\lambda_{2n}^2 - \lambda_{1n}^2)} - \frac{\cos n\omega t}{(\lambda_{1n}^2 - (n\omega)^2) \cdot (\lambda_{2n}^2 - (n\omega)^2)} - \\
 & - \frac{\cos \lambda_{2n}t}{(\lambda_{2n}^2 - (n\omega)^2) \cdot (\lambda_{2n}^2 - \lambda_{1n}^2)}.
 \end{aligned}
 \tag{15}$$

Thus, as a result of using the method of iterations and piecewise linear approximation we have managed to obtain an analytical and numerical solution for the analysis of joint bending and longitudinal oscillations of the bearing body frame of emergency and repair rail service car in the form of a model of an elastic rod of variable cross section, mass, bending and longitudinal stiffness as it moves along the track with periodic joint roughness.

In order to better understand and make thorough analysis and conclusions, simulation of the mathematical model was carried out using testing railcars with simulation workplace. The idea behind the experiment was to install in the frame control unit so called damping subfloor element. The results of the simulation experiment are summarized in Table 1.

As can be observed from Table 1, experimental data received from simulation is to the greatest extent in accordance with calculated mathematical model and very small deviation. Accordingly, the total stress-strain state with the introduction of the damping subfloor in the frame body structure of

Table

Checkpoint measurements of vibrations and stresses	The low-frequency component of the acceleration, Hz		The maximum amplitude of vibration acceleration, m/s ²		The longitudinal tension (in the center of the frame), MPa		Bending stress (in the center), MPa	
	Experiment	Theory	Experiment	Theory	Experiment	Theory	Experiment	Theory
Frame body control (including damping subfloor)	2.59	2.64	14.06	-	3.2	3.1	28	29.1
Frame body control (standard design)	2.07	2.17	15.2	-	3.3	3.2	31	30.7

railcars decreased by about 11 – 15 %, depending on the loading conditions that will facilitate the operation of the extension of the useful life. The total dynamic voltage does not exceed the tensile strength in the experiment ranged from 15.3 MPa to 41.23 MPa.

Hence, the results of both mathematical model based on experiment (simulation) is in line with proposed improvements for the railcars.

3. Conclusion

On the basis of numerical studies and comparative analysis with experiment (simulation) we have stated the following quality patterns:

1. Bending stresses appearing in the center of the length of the body frame of emergency and repair rail service car at speeds up to 50 km/h, as it moves along the track with periodic roughness, do not exceed the ultimate strength of the material, and in average range from 15 to 40 MPa depending on loading modes (the rate of motion).

2. Longitudinal stresses appearing in the center of the length of the body frame of emergency and repair rail service car at speeds up to 50 km/h, as it moves along the track with periodic roughness, are about 20 – 25 % of the bending stresses (from 3 to 10.4 MPa). They reach their maximum values at breakaway and braking modes.

3. The introduction of damping subfloor in frame design emergency replacement railcar reduces bending stresses in the frame 10 – 12 %, depending on the speed (respectively from 31 MPa to 28 MPa at a speed of 40 km/h – 11.07 %).

Accordingly, the use of mathematical modelling in modernization and extension of useful life of railcars is highly applicable given the importance of low cost maintenance and use of railway resources effectively. The results of the simulation and mathematical modelling will be implemented in real life conditions and will be compared with data on mathematical calculations and simulation.

References

- [1] Spiryagin M., Cole C., Sun Y.Q., McClanachan M., Spiryagin V. & McSweeney T. *Design and Simulation of Rail Vehicles*. Ground Vehicle Engineering series. 2014. CRC Press. 337 p.
- [2] Popp K. & Schiehlen W. *System Dynamics and Long-Term Behaviour of Railway Vehicles, Track and Subgrade*. 2013. Springer Science and Business Media. 488 p.
- [3] Navlicek V., Russ D. Some Problems of Dynamics of Locomotive. *Inst. Of Mechanical Eng.*, 1975, pp. 841-845.
- [4] Vershinsky S.V., Danilov V.N., Chelnokov N.I. *Wagon Dynamics: A Textbook*. Moscow: Transport, 1991.- 352 p.
- [5] Kamaev V.A. *Optimization of Parameters of Running Parts of Railway Rolling Stock*. Moscow. Mechanical Engineering, 1980.
- [6] Bogdevicius M. & Zygiene R. Simulation of dynamic processes of rail vehicle and rail with irregularities. *Journal of KONES Powertrain and Transport*. Vol 21, No. 2. 2015. pp. 21-26.
- [7] Bureika G. & Subačius R. Mathematical model of dynamic interaction between wheel-set and rail track. *Transport*. Vol. XVII, No. 2. 2002. 46-51.

[8] Sebesan I. & Baiasu D. Mathematical model for the study of the lateral oscillations of the railway vehicle. *Scientific Bulletin Series D: Mechanical Engineering*. University Politehnica Bucharest. Vol. 74, Issue 2. 2012. 51-66.

[9] Khromova G.A., Babadjanov A.A. Development of Analytical and Numerical Calculation Method to Dynamic Strength of the Bearing Body Frame of Governing Electric Locomotive. *Proc. of the 6th International Scientific and Technical Conference "Train Operation Safety"*. Moscow: MIIT, 26–28 October 2005, MIIT, Moscow, IY-87–89.

[10] Khromova G.A., Babadjanov A.A., Zakirov Sh.A. Development of Analytical and Numerical Calculation Method to Dynamic Strength of the Bearing Body Frame of Governing Electric Locomotive. *Journal "Industrial Transport of Kazakhstan"*, Kazakh University of Railways, No. 3 (9), 2006, 14–18.

[11] Huston R., Liu C.Q., *Formulas for Dynamic Analysis (Mechanical Engineering)*. Florida: CRC Press, 2001. 642 p.