

OSCILLOGRAPHIC MEASUREMENTS OF VALVE NOISE IN AUDIO FREQUENCY CHANNELS

By Miss. G. V. SUBHADRAMMA

WIRELESS LABORATORY, PHYSICS DEPARTMENT, BENARES HINDU UNIVERSITY

(Received for publication, October 23, 1952; received after revision, January 21, 1953)

ABSTRACT. An experimental study of over-all valve noise was made by an oscillographic method for different thermionic valves over a range of audio frequencies (375-1320 cycles/sec). The experimental results are summarised as follows:

(i) For a given anode voltage, the valve noise in any triode for any frequency channel was found to increase at first with the filament current attaining a maximum at some value of the filament current and then to decrease with further increase of filament current tending in some cases to a minimum value. In a particular tetrode, the noise voltage was found to increase with the increase of filament current tending to a saturation value.

(ii) For a given anode voltage, the *maximum* noise prevailed at the same value of filament current for all frequency channels but the magnitude of the maximum noise was found to increase with the increase of frequency channel tending in some cases to a saturation value.

(iii) For a given anode voltage, the magnitude of the *minimum* noise was found to vary with the frequency channel almost in the same manner as the maximum noise.

(iv) For a given filament current, the valve noise was found to decrease with the increase of anode voltage.

(v) The absolute values of the equivalent valve noise voltage was found to range from about 20 to about 200 microvolts in the several thermionic valves under the experimental conditions.

I. INTRODUCTION

The noise in thermionic valves consists mainly of the following types: (i) shot noise, (ii) flicker noise, (iii) thermal noise, (iv) ionization noise, and (v) partition noise. In high vacuum triodes, however, the shot noise and the flicker noise constitute the major part of the valve noise. Much work, both theoretical and experimental, has been done since the discovery of shot effect by Schottky (1918). Besides the pioneer work of Schottky (1918, 1922), Hartmann (1921), Fry (1925), Johnson (1928), Llewellyn and others, (1930) the work of Kanazouski and Williams (1930), Thacker and Williams (1932), Moullin and Ellis (1934), Williams (1936), Bell (1938), Percival and Harwood (1938), Rack (1931) and others yielded useful information regarding valve noise. Later works by North (1940), Bell (1941) and others are also of importance.

From the experimental point of view the measurements of valve noise in audio frequency channels are liable to serious error due to slightest electrical disturbances and require extremely careful shielding arrange-

ments. It was, therefore, thought desirable to use a cathode ray oscillograph for delineating the noise patterns in different audio frequency channels after having amplified the noise voltage in the usual way. Reliable measurements of noise voltage by the oscillographic method was possible even though extraneous electrical disturbances were not altogether eliminated. Measurements of over-all valve noise were made by this method for a range of audio frequencies (375 to 1320 c/s) in the case of several thermionic valves viz. (i) Philips A 415 (ii) Mullard 1HF (iii) RCA 1H4G (iv) Mullard PM2 and (v) Philips A442.

With a fixed anode voltage for each of the thermionic valves, the over-all noise voltage was measured for different filament currents within the range of audio frequency channels (375-1320 c/s). From these measurements the variation of maximum noise in each valve with frequency channel was found. The variation of valve noise with varying plate voltages for maximum filament current was also studied in the same range of audio frequencies for one particular valve (Mullard PM2).

2. EXPERIMENTAL METHOD AND PROCEDURE

A suitable parallel combination of a coil and a condenser was placed in the anode circuit of the thermionic valve under investigation and the anode and filament of the valve were connected to input terminals of a high gain amplifier through a suitable blocking condenser. The coil-condenser combination was arranged to cover the desired range of resonance frequencies for the parallel circuits. It was also ensured that the equivalent impedance of the combination at its resonance frequency was very much higher than the impedance of the voltage amplifier which was used to amplify the valve noise. Under such condition, the noise frequencies in the valve ranging from 0 to ∞ were confined, within a very narrow band, to the resonance frequency of the parallel circuit at the input end of the amplifier.

The amplified noise voltage for any frequency channel within the desired range was then applied to the Y-plates of an oscillograph, the linear time base having been connected to the X-plates. The pick-up from the 50 cycle converter lines invariably appeared on synchronization along with the superposed valve noise corresponding to the resonance frequency of the coil-condenser combination. The 50 cycle pick-up was, however, eliminated to a considerable extent by using a phase inverter unit constructed for the purpose and on further amplifying the noise voltage with the help of oscillograph amplifier, the average amplitude of the noise pattern was accurately measured on the fluorescent screen. Corresponding to the average amplitude in cms. of the noise pattern for each frequency channel, the equivalent noise voltage was obtained with the help of an audio oscillator and an attenuator. For equivalent noise measurements, calibration curves were drawn, one for each frequency channel, showing different A/F input voltages against corresponding amplitudes as measured in cms. on the oscillographic screen.

3. EXPERIMENTAL DETAILS

The experimental set up for the measurement of valve noise is illustrated in figure 1. The essential parts of the arrangement are as follows :

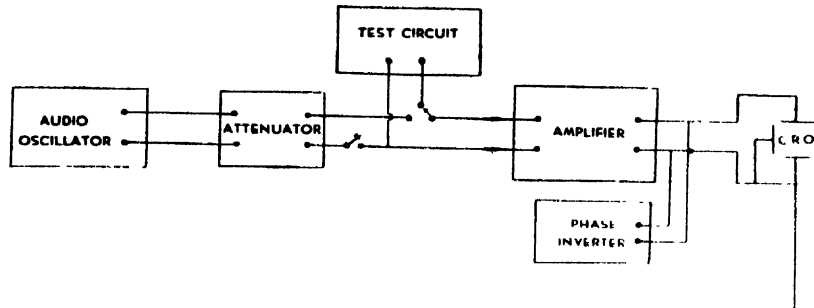

FIG. 1
The experimental set-up

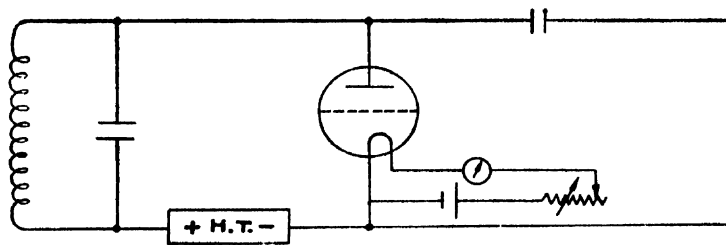

FIG. 2
The test circuit

(i) *Test circuit.* The thermionic valve under investigation with suitable coil condenser parallel combination in its anode circuit was placed across the input impedance of a voltage amplifier through a blocking condenser. The coil in the combination was a 30-henry choke and the capacitance of the condenser ranged from $0.0005 \mu\text{F}$ to $0.006 \mu\text{F}$, so that the resonance frequency of the combination could be varied from 375 to 1320 cycles/sec* and the equivalent impedance of the combination at its resonance frequency was very much higher than the input impedance of the amplifier.

The circuit diagram of the test circuit with all the necessary connections is shown in figure 2. The coil condenser combination was kept in a double-walled metal enclosure. Other parts and connecting wires were all properly shielded.

(ii) *A/F voltage amplifier.* A Philips Modulation Amplifier (type 2845) with a maximum gain of 2300 was employed for amplifying the over-all noise

* The resonance frequencies were calculated without considering the self-capacitance of the choke. The self-capacitance would cause a lowering of the frequency value to the extent of about 8% for the smallest value of the condenser used in these experiments. The observed noise patterns on the oscillographic screen showed also the same order of frequencies.

voltage across the thermionic valve under investigation. Suitable input and output channels were used. The high-tone filter in the amplifier unit was set for the straight line portion of the frequency characteristic and the low-tone filter was adjusted to cut off low frequencies as far as possible. The amplifier was worked with 220 volts of 50 cycles/sec.

(iii) *Cathode ray tube.* A Cossor's oscillograph was employed to delineate the noise patterns for different audio frequency channels. The noise pattern for any particular frequency channel was found superposed on the trace of the 50 cycle pick-up from the A/C power lines from the converter.

(iv) *Phase inverter unit.* The phase inverter unit, constructed for eliminating the 50 cycle pick-up, was essentially a unit of continuously varying phase and amplitude of the 50 cycle e. m. f. In this unit one arm of the circuit consisted of two similar capacitances and a potentiometer resistance in series, while the other arm had two similar inductances in series with another potentiometer resistance. Requisite conditions were satisfied regarding the magnitude of the elements. The output connections were taken from the variable points on the potentiometer resistances so that the phase of the output e.m.f. could be varied by changing the variable points on the two potentiometer resistances. The amplitude of the output e.m.f. was varied with a potentiometer across the supply voltage. The circuit for the phase inverter unit is shown in figure 3.

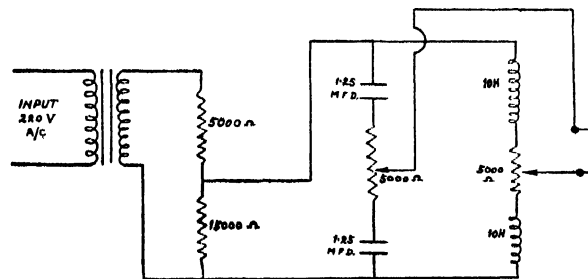

FIG. 3
Phase inverter

The phase inverter output terminals were connected across the output of the A/F voltage amplifier. There was no shunting effect of the phase inverter, the output impedance of the phase inverter being very much higher than the output impedance of the amplifier.

4. EXPERIMENTAL RESULTS

The variation of over-all valve noise with filament current and with frequency were studied in the case of all the valves under investigation with a fixed anode voltage. The grid of each valve was kept 'floating'. This evidently did not correspond to the usual operating conditions. In the case of the tetrode valve, the screen-grid voltage was about 70 volts.

The experimental results showing the variation of noise voltage with filament current are graphically shown in figures 4-6. It is to be noted

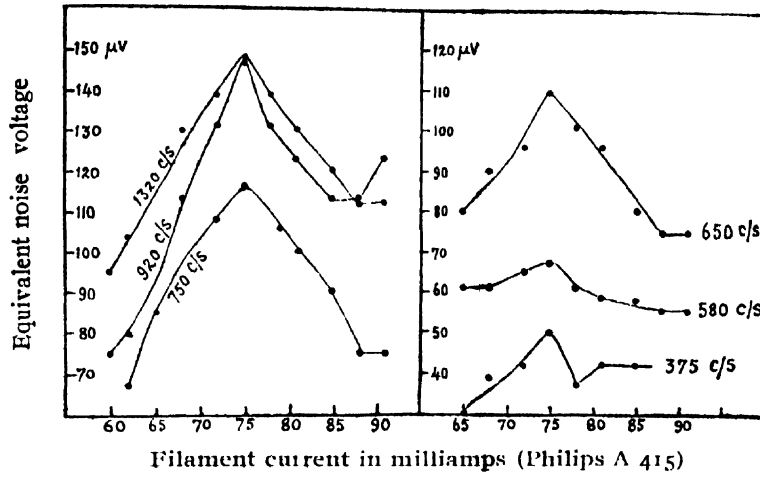

FIG. 4

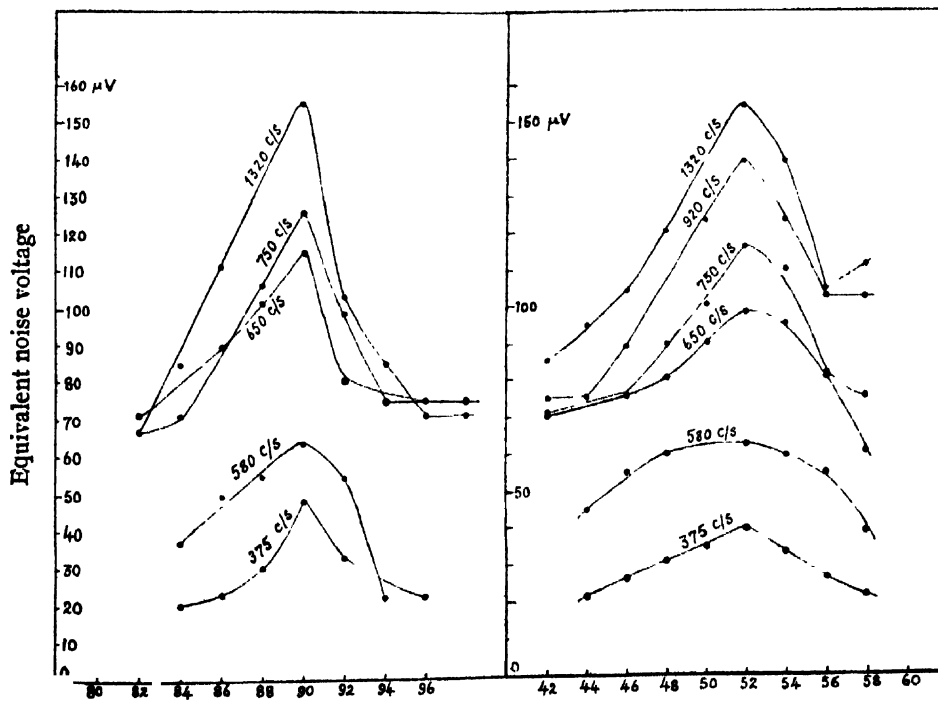

FIG. 5

Mullard 1HF

RCA 1H 4-G

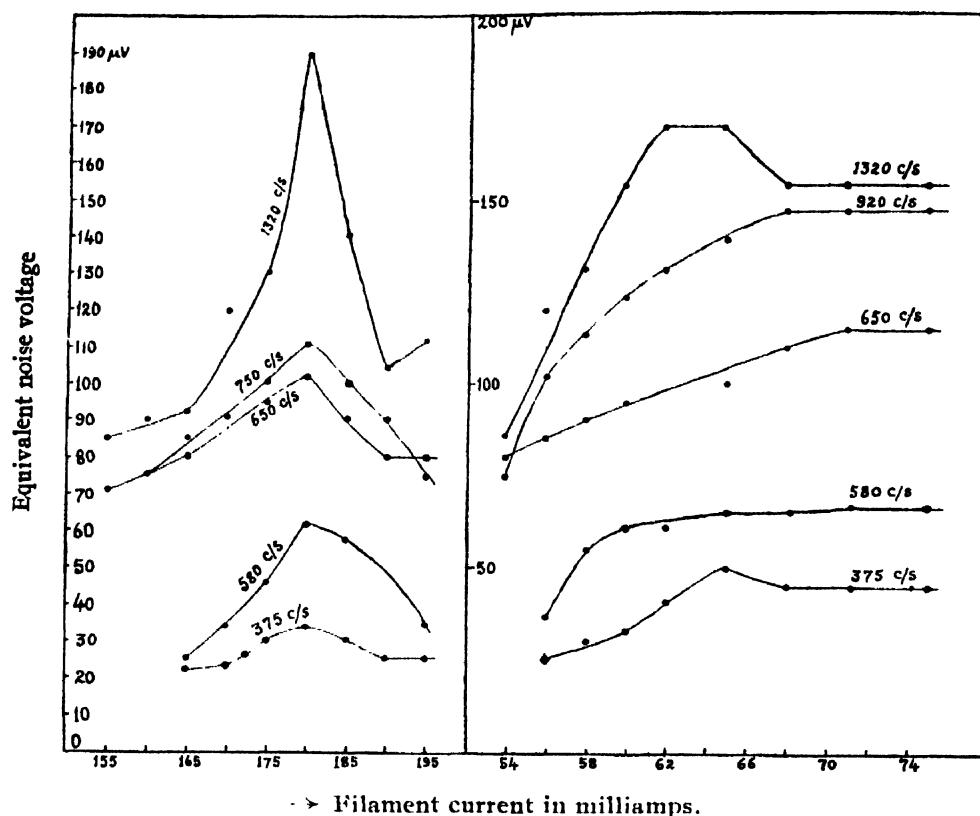

FIG. 6

Mullard PM 2

Philips A 442

that for all the frequency channels the equivalent noise voltage in all the triodes increased with the filament current and after attaining a maximum at a certain value of filament current decreased again to some minimum value. In the case of Philips A442 tetrode, the valve noise for the different frequency channels increased with filament current attaining a saturation value.

The maximum and the minimum values of the over-all valve noise in different triode valves, as determined for different frequency channels, are shown in figures 7 and 8. For all frequency channels the maximum noise was found to be at the same value of filament current but the maximum noise value in case of all the valves was found to increase with increase of frequency channel and in some cases it attained or tended to attain a saturation value. The minimum noise for all the valves showed a similar variation with frequency channel.

The variation of valve noise for a fixed filament current with varying anode voltages for three frequency channels was studied for only one valve (Mullard PM2). The valve noise was found to decrease with the increase of anode voltage. The experimental results are graphically shown in figure 9.

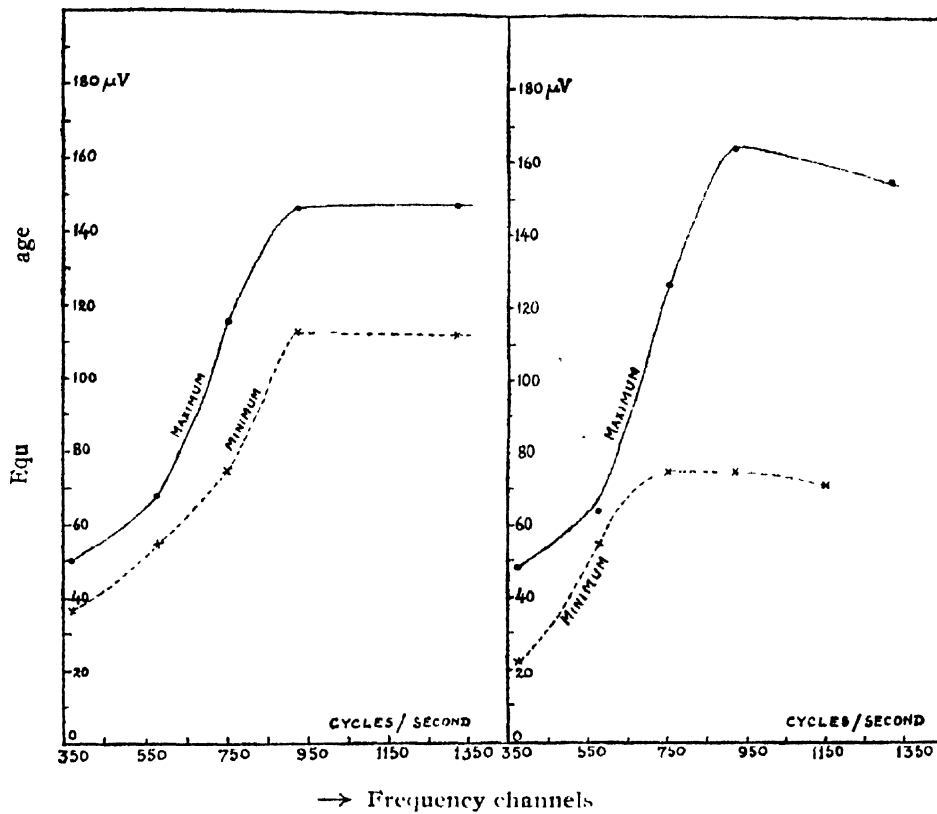

FIG. 7

Philips A 415

Mullard IIIF

5. CONCLUSIONS

The observed variation of valve noise with varying filament current for a fixed anode voltage showed the effect of space charge on the valve noise, as in the work of previous investigators. The observed increase in maximum and minimum valve noise with the increase of frequency channel in the experimental range (375-1320 cycles/sec.) is indeed significant. It is doubtful whether this signifies the validity of Hartman-Schottky hypothesis. According to this hypothesis, a cooling is produced in the emitter after the emission of an electron and the emission of next electron become less probable for a short time compared to the frequency of the shot noise. It is accordingly expected that at very low frequencies which correspond to large time periods, the magnitude of the shot noise must be small. The observed decrease of valve noise with the increase of anode voltage for a given filament current in the case of one triode valve in three frequency channels within the experimental range is, however, contrary to expectation, as with higher anode voltage the space charge decreases and the shot noise is expected to increase with the increase of anode voltage. This requires further investigation. It was also found that the observed magnitude of the over-all valve

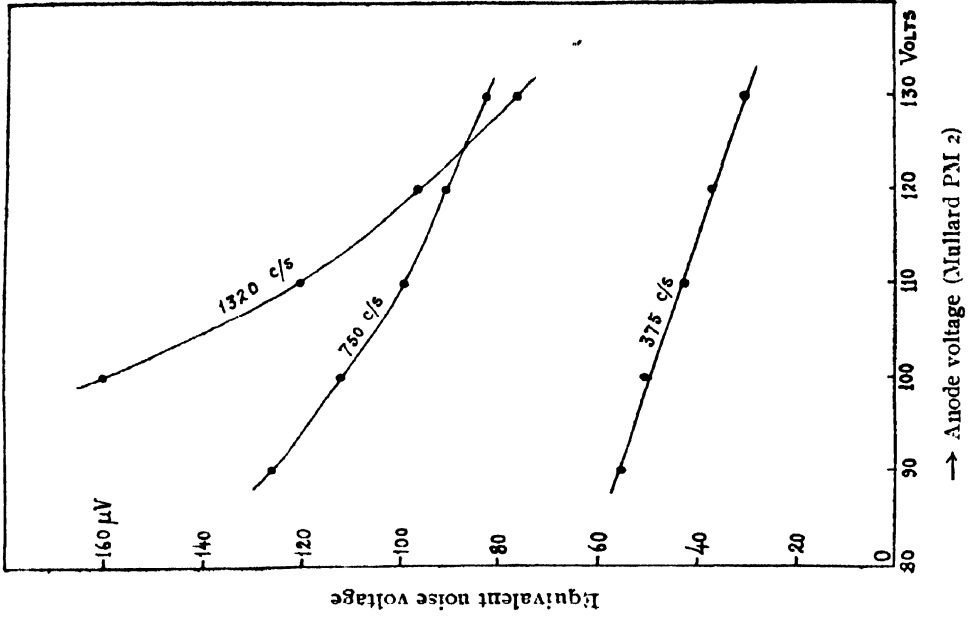

FIG. 9

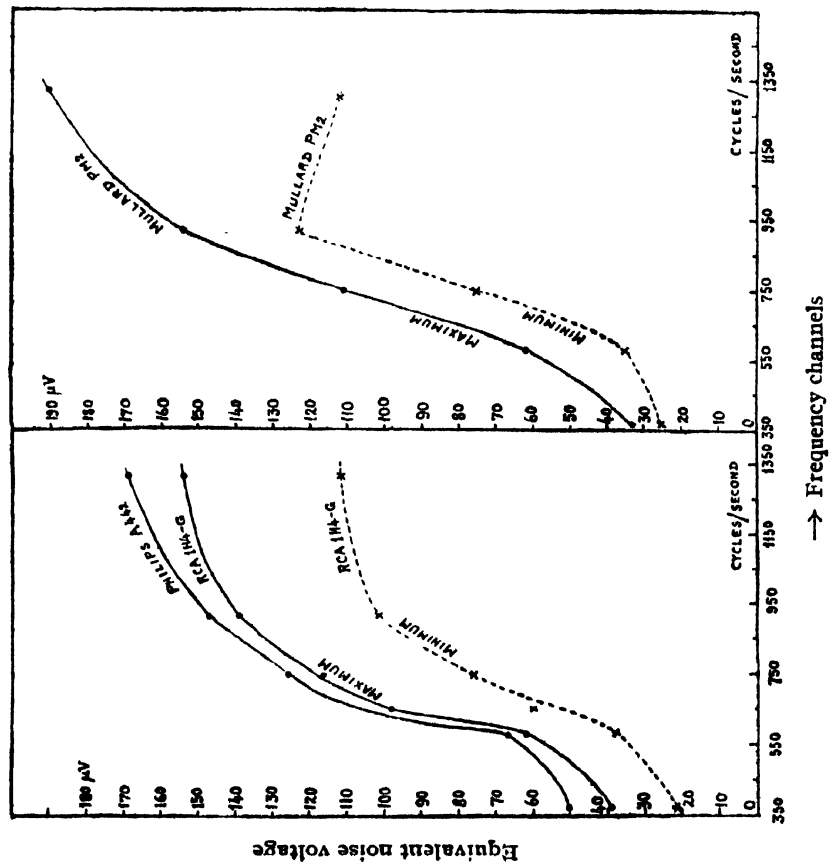

FIG. 8

noise was appreciably higher than the value of the shot noise obtained according to Llewellyn's method of calculation. This is likely to be due to the preponderance of the flicker effect in the particular range of audio frequency channels.

6. ACKNOWLEDGMENTS

The author wishes to express her sincere thanks to Dr. S. R. Khastgir, D. Sc., F. N. I., for help and guidance during the progress of the work. Thanks are also due to Messrs, M. P. Varma, M. Sc. and B. A. P. Tantry, M. Sc. for their valuable technical assistance.

REFERENCES

- Bell, A. D., 1938, *J. I. E. E.*, **82**, 522.
Bell, A. D., 1941, *Ibid.*, **89**, 207.
Fry, T. C., 1925, *J. Frank. Inst.*, **199**, 203.
Hartmann, C. A., 1921, *Ann. der Physik*, **66**, 51.
Johnson, J. B., 1928, *Phys. Rev.*, **32**, 97.
Kanazowski, H. N., and Williams, N. H., 1930, *Phys. Rev.*, **36**, 13.
Llewellyn, F. B., 1930, *Proc. I. R. E.*, **18**, 24.
Moullin and Ellis, 1934, *J. I. E. E.*, **74**, 323.
North D. O., 1940, *R. C. A. Review*, **4**, 441.
,, *Ibid.*, **5**, 224.
Percival W. S., and Harwood, W. L., 1938 *Wireless Engineer and E. W.*
Rack, A. J., 1938, *Bell Sys. Tech. Jour.*, **17** (Oct).
Schottky, W., 1918, *Ann. der Physik*, **62**, 541.
,, 1922, *Ibid.*, **63**, 157.
Thacker, E. W., and Williams, N. H., 1932, *Phys. Rev.*, **39**, 174
Williams, F. C., 1936, *J. I. E. E.*, **78**, 326.
,, *Ibid.*, **89**, 219.