



Aalborg Universitet

AALBORG UNIVERSITY  
DENMARK

## Determination of p-y Curves using Finite Element Modelling for Bucket Foundation in Undrained Soft and Medium Clay

Hvidberg, Mogens Bonde; Ibsen, Lars Bo

*Publication date:*  
2017

*Document Version*  
Publisher's PDF, also known as Version of record

[Link to publication from Aalborg University](#)

*Citation for published version (APA):*  
Hvidberg, M. B., & Ibsen, L. B. (2017). *Determination of p-y Curves using Finite Element Modelling for Bucket Foundation in Undrained Soft and Medium Clay*. Department of Civil Engineering, Aalborg University. DCE Technical Memorandum No. 65

### General rights

Copyright and moral rights for the publications made accessible in the public portal are retained by the authors and/or other copyright owners and it is a condition of accessing publications that users recognise and abide by the legal requirements associated with these rights.

- ? Users may download and print one copy of any publication from the public portal for the purpose of private study or research.
- ? You may not further distribute the material or use it for any profit-making activity or commercial gain
- ? You may freely distribute the URL identifying the publication in the public portal ?

### Take down policy

If you believe that this document breaches copyright please contact us at [vbn@aub.aau.dk](mailto:vbn@aub.aau.dk) providing details, and we will remove access to the work immediately and investigate your claim.

# **Determination of p-y Curves using Finite Element Modelling for Bucket Foundation in Undrained Soft and Medium Clay**

**Mogens Bonde Hvidberg  
Lars Bo Ibsen**



Aalborg University  
Department of Civil Engineering

**DCE Technical Memorandum No. 65**

**Determination of p-y Curves using Finite Element  
Modelling for Bucket Foundation in Undrained Soft and  
Medium Clay**

by

Mogens Bonde Hvidberg  
Lars Bo Ibsen

June 2017

© Aalborg University

## Scientific Publications at the Department of Civil Engineering

**Technical Reports** are published for timely dissemination of research results and scientific work carried out at the Department of Civil Engineering (DCE) at Aalborg University. This medium allows publication of more detailed explanations and results than typically allowed in scientific journals.

**Technical Memoranda** are produced to enable the preliminary dissemination of scientific work by the personnel of the DCE where such release is deemed to be appropriate. Documents of this kind may be incomplete or temporary versions of papers—or part of continuing work. This should be kept in mind when references are given to publications of this kind.

**Contract Reports** are produced to report scientific work carried out under contract. Publications of this kind contain confidential matter and are reserved for the sponsors and the DCE. Therefore, Contract Reports are generally not available for public circulation.

**Lecture Notes** contain material produced by the lecturers at the DCE for educational purposes. This may be scientific notes, lecture books, example problems or manuals for laboratory work, or computer programs developed at the DCE.

**Theses** are monographs or collections of papers published to report the scientific work carried out at the DCE to obtain a degree as either PhD or Doctor of Technology. The thesis is publicly available after the defence of the degree.

**Latest News** is published to enable rapid communication of information about scientific work carried out at the DCE. This includes the status of research projects, developments in the laboratories, information about collaborative work and recent research results.

Published 2017 by  
Aalborg University  
Department of Civil Engineering  
Thomas Manns Vej 23  
DK-9220 Aalborg Ø, Denmark

Printed in Aalborg at Aalborg University

ISSN 1901-7278  
DCE Technical Memorandum No. 65

# Determination of p-y Curves using Finite Element Modelling for Bucket Foundations in Undrained Soft and Medium Clay

Mogens Bonde Hvidberg<sup>1</sup> Lars Bo Ibsen<sup>2</sup>

*Department of Civil Engineering, Aalborg University*

## Abstract

In many years the types of foundation, such as monopiles and bucket foundation which are used in the offshore wind turbine industry, have been analysed analytically with formulations that are based on much slender piles, then are used today. Because of that, the analytical calculation is not describing the connection between the horizontal bearing capacity of the soil and the displacement of the foundation accurate, in particular for the bucket foundation because of the much smaller slenderness of the profile. Numerical modelling is used to examine that bearing capacity the bucket foundation has in soft and medium clay at different dimensions of the bucket, to a horizontal displacement. After that a mathematical formulation is determined, based on (Reese et al, 1975), so it is possible to get a more accurate result in an analytical calculation.

## 1 Introduction

The goal with this study is to investigate the soil reaction to horizontal displacement of a bucket foundation in clay using finite element modelling. This will be done for undrained soft and medium clay. The finite element program PLAXIS 3D is used to simulate the soil reaction, because it has some advanced material models, which are necessary to obtain an accurate result. There are made six models, which vary in the geometry of the bucket, i.e. the diameter,  $D$  and the length of the skirt,  $L$ . Simultaneously the strength of the clay will vary, which is described by the undrained shear strength,  $c_u$ . There are roughly four steps in the way to make the p-y curves and thence a mathematical formulation of the soil reaction on horizontal displacement.

1. The bucket will be exposed to a prescribed horizontal displacement and the stresses between the bucket and the soil will build up. The stresses are then extracted from PLAXIS 3D.
2. The prescribed displacement will at this point be removed and the plastic displacements are afterwards extracted from PLAXIS 3D.
3. Step 1 and 2 are repeated until the required maximum displacement is reach or the soil body collapses.
4. The p-y curves are then normalized, so they do not depend on the depth,  $z$ , and the displacement,  $y$ , and

a best fit can be made for every model. The mathematical formulation is then build on the best fits.

## 2 Theory

The analytical formulations, which are used to describe the soil reaction to a horizontal displacement today, are based on field tests. These field tests are made on piles with high slenderness. These formulations can however not be used to describe the p-y curves for bucket foundations, because the bucket has a low slenderness compared to the piles in the field tests. The bucket foundation will react in a more rigid way to a horizontal load, as it can be seen in figure 1.

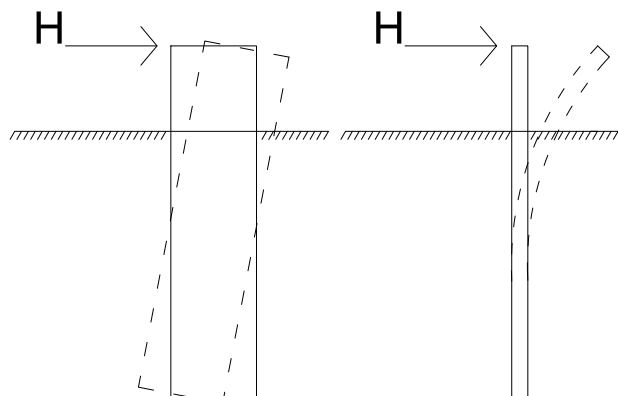

Figure 1: Reaction to a horizontal load.

### 2.1 Material Model

To model the behaviour of the soil accurately, the Hardening Soil Small-Strain material model (HSsmall) is

<sup>1</sup>M.Sc. Student, Department of Civil Engineering, Aalborg University, Denmark

<sup>2</sup>Professor, Department of Civil Engineering, Aalborg University, Denmark

used, which is an extended version of Hardening Soil. In The Hardening Soil model the stiffness are stress-dependent, but HSsmall describes the behaviour at small strain more realistic by adding more stiffness at small strains. As a result, the calculation time will increase, but the time is well spent, due to the load scenario in this study. If HSsmall is not chosen the deformations might be overestimated and therefore underestimate the stresses, which makes HSsmall a reasonable choice.

As the name indicates, HSsmall takes hardening into account. There are two types of hardening, which are shear hardening and compression hardening. Shear hardening is mainly controlled by the triaxial loading stiffness,  $E_{50}$ , and compression hardening is mainly controlled by the oedometer loading stiffness,  $E_{oed}$ . The elastic region is controlled by the triaxial unloading stiffness,  $E_{ur}$ , which can be seen in figure 2

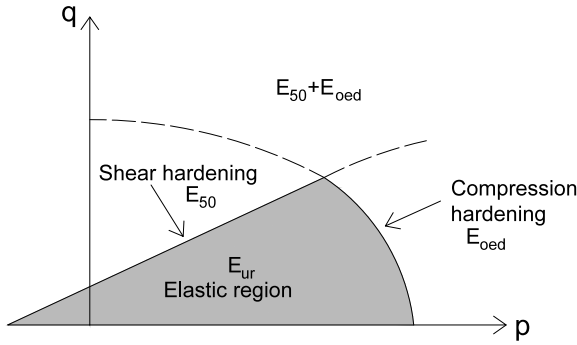

Figure 2: Yield criteria for HSsmall in 2D.

The three stiffness moduli of elasticities and the shear moduli are as a starting point stress-dependent, and follow the power law in the form of eq. 1

$$E_{50} = E_{50}^{ref} \cdot \left( \frac{c \cdot \cos(\varphi) - \sigma'_3 \cdot \sin(\varphi)}{c \cdot \cos(\varphi) + p_{ref} \cdot \sin(\varphi)} \right)^m \quad (1)$$

There are however two ways in PLAXIS 3D to model the undrained behaviour, where Undrained (B) is used. In Undrained (B), the effective stiffness parameter and the undrained strength parameter are used, which allows  $c_u$  to be an input parameter. This does, however, that the moduli no longer are stress dependent, because  $\varphi$  is equal to zero [Brinkgreve et al., 2016].

Effective parameters for soft and medium clay are given in a table, which can be seen in [Hvidberg, 2017], however the shear modulus,  $G_0^{ref}$ , and  $\gamma_{0.7}$  are not in the table, and are necessary in order to use HSsmall.  $G_0^{ref}$  is set to be four times  $E_{oed}$  and  $\gamma_{0.7}$  is definite by eq. 2 [Brinkgreve et al., 2016].

$$\gamma_{0.7} \approx \frac{1}{9G_0^{ref}} (2c'(1 + \cos(2\varphi')) - \sigma'_1(1 + K_0)\sin(2\varphi')) \quad (2)$$

It is necessary to find a  $c_u$  that correspond to the effective parameters, and this is done using SoilTest,

which is a program in PLAXIS, and eq. 3, which is the SHANSEP formulation [Hvidberg, 2017] [Steenfelt and Sørensen, 2013].

$$\left( \frac{c_u}{\sigma'_0} \right)_{oc} = A \cdot (OCR)^m \quad (3)$$

All the input parameters can be seen in table 1.

$c_u$	61	66	$[kN/m^2]$
$\gamma^2$	7	9,1	$[kN/m^3]$
$p_{ref}$	100	100	$[kPa]$
$E_{50}^{ref}$	1840	3000	$[kN/m^2]$
$E_{oed}^{ref}$	2500	1200	$[kN/m^2]$
$E_{ur}^{ref}$	5520	9000	$[kN/m^2]$
$\gamma_{0.7}$	$6,79E^{-4}$	$4,90E^{-4}$	$[-]$
$G_0^{ref}$	22080	36000	$[kN/m^2]$
$K_0$	0,55	0,51	$[-]$
power m	1	1	$[-]$
POP	0	50	$[-]$

Table 1: Parameters in HSsmall.

### 3 Numerical model

To model the reaction in the soil to a displacement and form the p-y curves, six numerical models are made in PLAXIS 3D. The models will vary in diameter, D, length of the skirt, L, and the undrained shear strength,  $c_u$ , which can be seen in table 2.

Model nr.	D [m]	L [m]	$c_u [kPa]$
1	10	10	61
2	10	10	66
3	15	15	61
4	15	15	66
5	20	20	61
6	20	20	66

Table 2: Model overview.

#### 3.1 Model set-up

First of all, to ensure accurate results, the model domain has to be big enough for the soil failure mechanism to fully develop. This is investigated in the convergence analysis, and the size of the model domain is shown in figure 3.

There can arise stress and strain concentrations around sharp edges, like the bottom of the bucket. In order to avoid this, an extended fictive bucket is modelled, with the length of 0.2L [Vaitkunaite, 2012], both horizontal and vertical, as it is seen in figure 3.

To make the p-y curves, the stresses between the bucket and the soil, which are called the interface stresses, are required. For the model to provide accurate interface stresses, the mesh is refined around the bucket. The fineness factor is found from the convergence analysis and is set to 0.15.

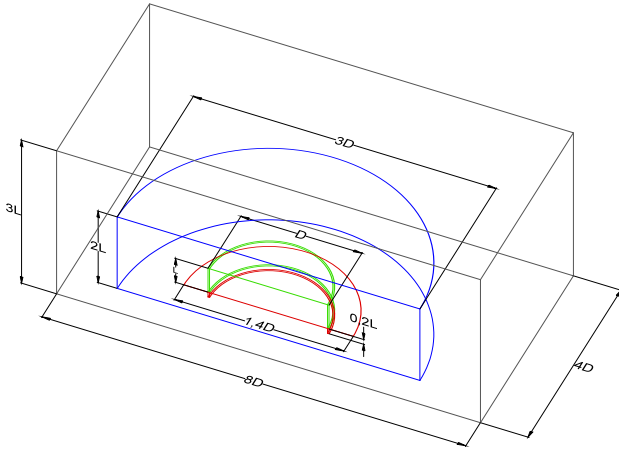

Figure 3: Dimensions of the model domain as a function of D and L. The bucket foundation is green, extended bucket is red and volume with refined mesh is blue.

### 3.2 Calculation stages

To generate the data to the p-y curves, various stages must be calculated. There are five basic stages. The first two stages (phase 0 and 1) are the initial phase and the installation phase, wherein respectively the soil and the construction are defined in the model. In the third stage (phase 2) all the deformations from the installation are set to zero. In the fourth stage (phase 3,5,7...) a prescribed displacement is activated to move the bucket horizontal. In the fifth stage (phase 4,6,8...) the prescribed displacement is deactivated and only the plastic deformation will remain because of the elasto-plastic behaviour in the soil. Stage four and five are repeated until all the wanted phases are completed or the soil body collapses.

### 3.3 Data processing

It is necessary to process the output to get the p-y curves. The stresses are taken from the interfaces, as they provide more reliable results and are processed in the same way as [Østergaard et al., 2015]. The output stresses from the interface are the effective normal stress  $\sigma'_N$  and the two shear stresses,  $\tau_1$  and  $\tau_2$ . The distribution of  $\sigma'_N$  and  $\tau_1$  are shown in figure 4. The shear stress  $\tau_2$  is ignored, because it acts vertical along the skirt and do not contribute to the soil reaction pressure on the bucket.

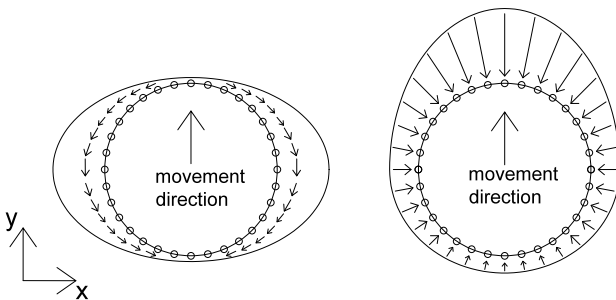

Figure 4: Distribution of the effective normal stress  $\sigma'_N$  and the shear stress  $\tau_1$  at a movement in the y-direction.

To determine the soil reaction force, the stresses are integrated over the skirt area, in the way of eq. 4

$$F_y = \int_A (\sigma'_n \cdot \sin\theta + \tau_1 \cdot \cos\theta) dA \quad (4)$$

To avoid having to use eq. 4 on every interface element, the bucket is divided down the skirt into layers. Every layer is then divided into slices, as it can be seen in figure 5. The average stress in each slice is multiplied with the area to find the average force of the slices. The sum of each average force in a layer is then divided by the thickness of the layer to find p for that layer.

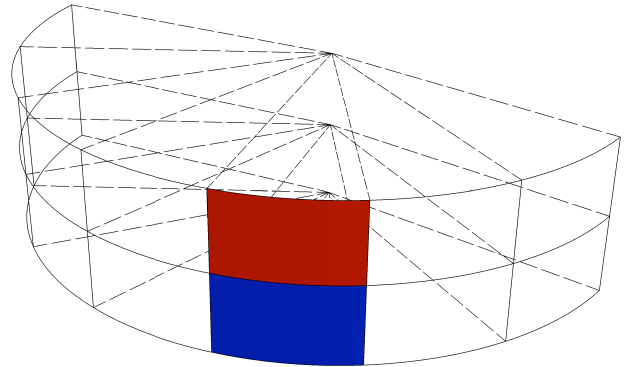

Figure 5: The subdivision of the bucket.

## 4 Results

The results are going to be processed as follows:

1. The raw data from the numerical models are plotted.
2. The effect from stress concentrations by the edge are trimmed away.
3. The bearing capacity, p, is normalized with a new formulation of the ultimate bearing capacity,  $p_u$  and the displacement is normalized with an expression of at which displacement  $p_u$  arise,  $y_p$ .
4. A mathematical formulation is formed by taking fundamental basis in (Reese et al, 1975) which is a formulation for stiff clay below the water table.

### 4.1 Plotting the p-y curves

For every layer of the bucket division they will be plotted a p-y curve. The associated depths to the p-y curves are the depth at the middle of each layer. Because of the stress concentrations at the edge of the bucket, the top and bottom curves are trimmed away. The p-y curve for model 6 is plotted in figure 6.



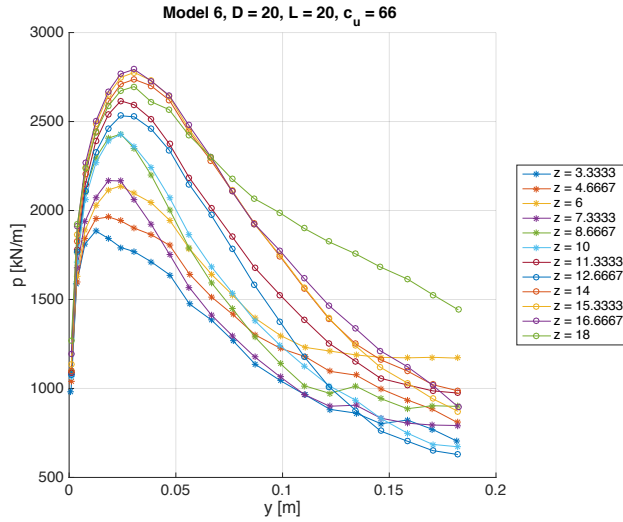

Figure 6: Raw data from model 6 with trimmed edges.

#### 4.2 Normalizing the p-y curves

There is made a new formulation for the ultimate bearing capacity,  $p_u$ , which take fundamental basis in the  $p_u$  formulation from [Matlock, 1970], where the soil is exposed to two types of failure, which are seen in figure 7.

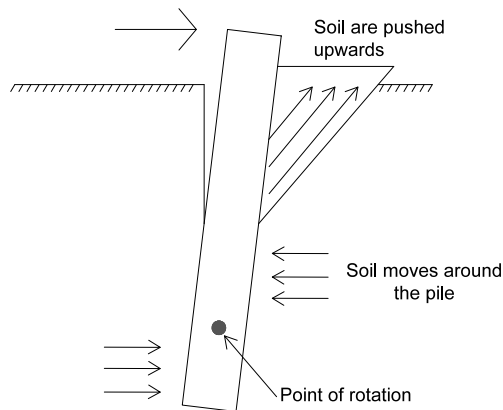

Figure 7: Failure mechanisms for a pile or bucket exposed to a horizontal load.

The ultimate bearing capacity from every p-y curve in the models are plotted against Q, which are described by eq. 5. The first expression describes a linear increase in Q, which corresponds to the top failure mechanism at figure 7 and the second expression describes a constant Q, which corresponds to the bottom failure mechanism at figure 7. The same tendency can be seen in the ultimate bearing capacity from the p-y curves in the model, and the plots are seen in figure 8 to 11, where the soft and medium clay are divided. At first  $X=1$ .

$$Q = \min \begin{cases} (3 \cdot c_u + \gamma \cdot z)D + c_u \cdot z \\ X \cdot c_u \cdot D \end{cases} \quad (5)$$

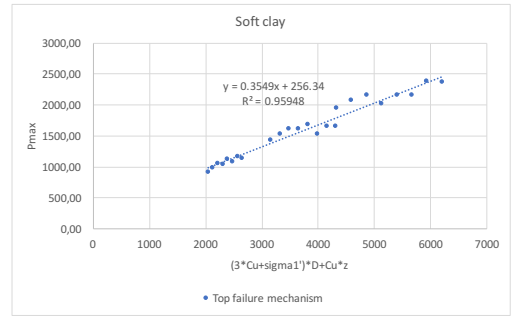

Figure 8:  $P_{max}$  as a function of Q for top failure mechanism.

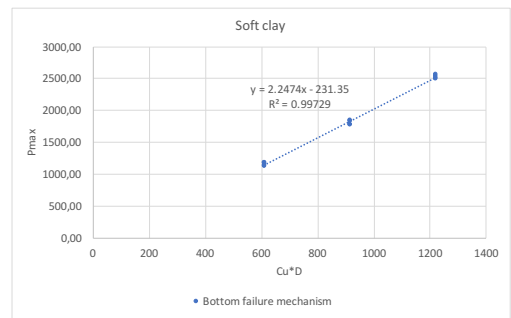

Figure 9:  $P_{max}$  as a function of Q for bottom failure mechanism.

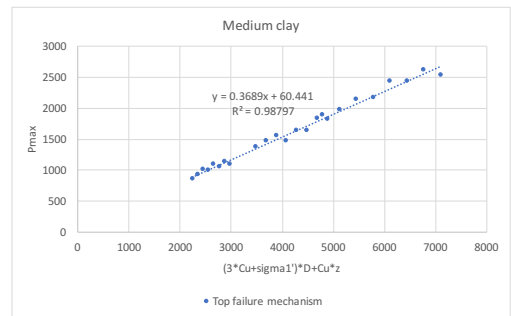

Figure 10:  $P_{max}$  as a function of Q for top failure mechanism.

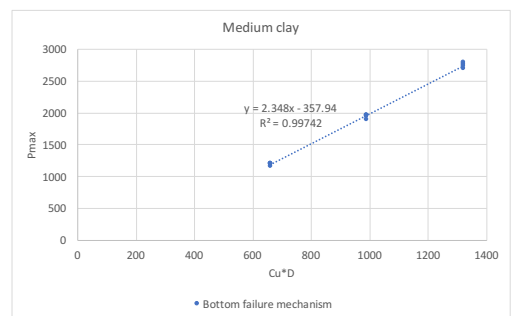

Figure 11:  $P_{max}$  as a function of Q for bottom failure mechanism.

The chance between the to failure mechanism happen at a critical depth, which is described by eq. 6 for figure 8 to 11, where 15 is to total number of layers, and 10 is the layer where the chance between the two failure mechanisms are noticed.

$$z_t = \frac{L}{15} \cdot 10 + \frac{L}{15} \cdot 0.5 \quad (6)$$

To find the X value in eq. 5, the two expressions are put equal to each other at  $z_t$ , for all six models. The X values from the models are then plotted against the vertical effective stress,  $\sigma'_{1,eff}$ , at the bottom of the bucket, as seen in figure 12 and 13. This is done to find one expression for X to respectively soft and medium clay, which are described by eq. 7.

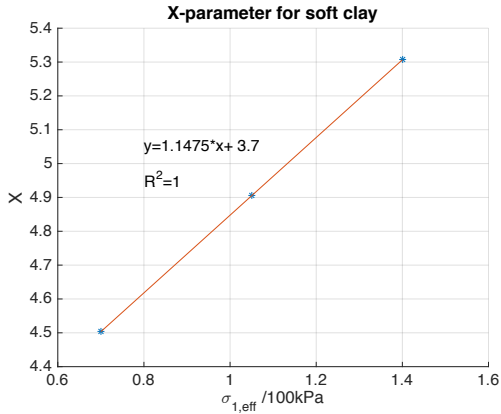

Figure 12: X as a function of  $\sigma'_{1,eff}$  for soft clay.

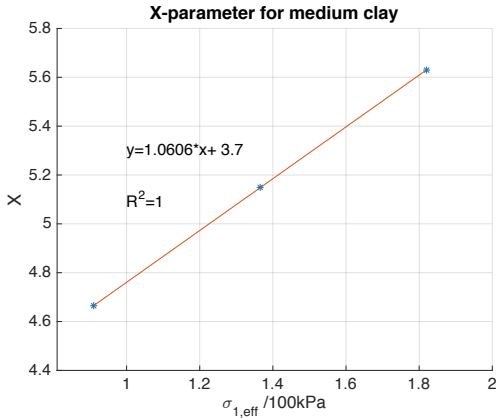

Figure 13: X as a function of  $\sigma'_{1,eff}$  for medium clay.

$$X = \begin{cases} 1.1475 \cdot \left( \frac{\gamma' \cdot L}{100kPa} \right) + 3.7 & \text{for soft clay} \\ 1.0606 \cdot \left( \frac{\gamma' \cdot L}{100kPa} \right) + 3.7 & \text{for medium clay} \end{cases} \quad (7)$$

The new expression for the ultimate bearing capacity can therefore be determined by eq. 8 for soft clay and eq. 9 for medium clay.

$$p_u = \begin{cases} 0.3549 \cdot Q + 256.34 & z < z_t \\ 0.3676 \cdot Q + 144.95 & z > z_t \end{cases} \quad (8)$$

$$p_u = \begin{cases} 0.3689 \cdot Q + 60.441 & z < z_t \\ 0.3557 \cdot Q + 116.18 & z > z_t \end{cases} \quad (9)$$

To find an expression for the displacement at the ultimate bearing capacity,  $y_p$ , a mean value of the displacement at the peak was taken for each model, and the mean value was plotted against the stiffness,  $E_{50}$  and the diameter, D. This was done separately for soft and medium clay, as it can be seen in figure 14 and 15, and  $y_p$  can be determined from eq. 10.

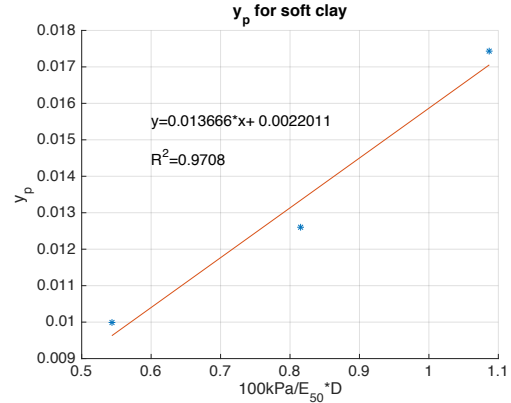

Figure 14:  $y_p$  as a function of  $E_{50}$  and D.

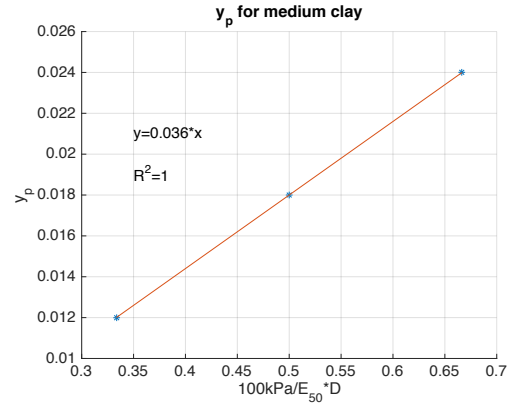

Figure 15:  $y_p$  as a function of  $E_{50}$  and D.

$$y_p = \begin{cases} 0.0136 \cdot \left( \frac{100kPa}{E_{50}} \cdot D \right) + 0.0022 & \text{for soft clay} \\ 0.036 \cdot \left( \frac{100kPa}{E_{50}} \cdot D \right) & \text{for medium clay} \end{cases} \quad (10)$$

When  $p_u$  and  $y_p$  are found the raw p-y curves are normalized, as it can be seen in figure 16 for model 6.

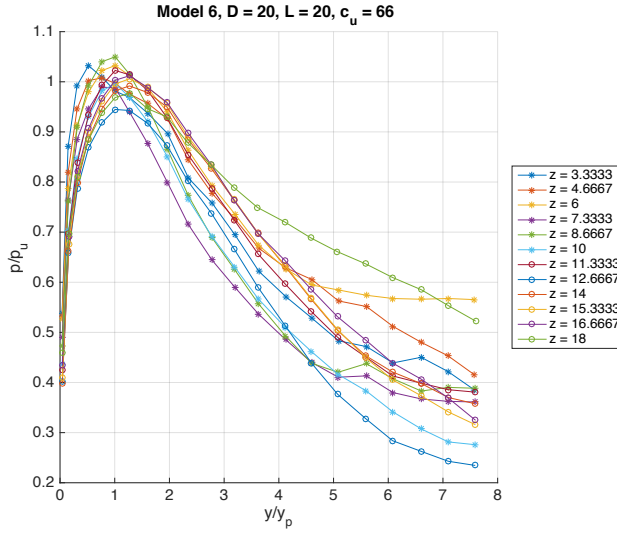

Figure 16: The normalization of model 6.

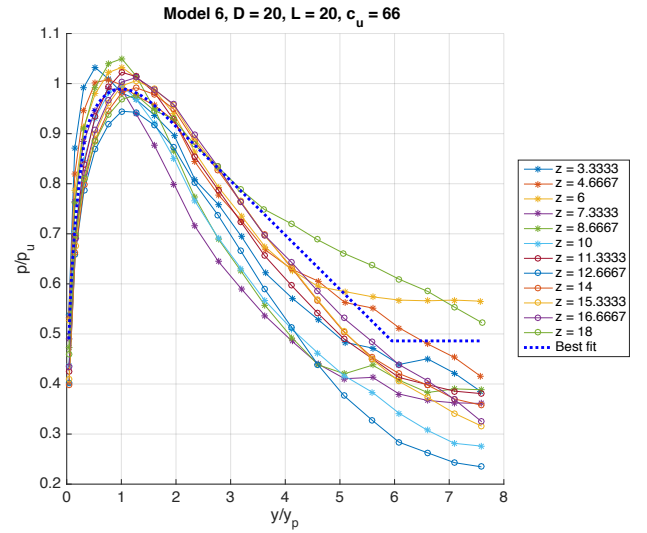

Figure 17: Best fit for model 6.

## 5 Mathematical formulation

There is made a best fit for every model, which takes fundamental basis in (Reese et al, 1975), which is described in [Meyer and Reese, 1979]. The fitting parameters a to f in eq. 11 are determined by the program MATLAB, where  $A_s$ ,  $T_1$  and  $T_2$  are found in table 3.

	$A_s$	$T_1$	$T_2$
Soft clay	0,5	4	14
Medium clay	0,35	5	17

Table 3: Parameters for the intervals.

$$\frac{p}{p_u} = \begin{cases} a \cdot \left(\frac{y}{y_p}\right)^b & y < A_s \\ a \cdot \left(\frac{y}{y_p}\right)^b - c \cdot \left(\frac{y - A_s \cdot y_p}{A_s \cdot y_p}\right)^d & y < T_1 \cdot A_s \\ a \cdot (T_1 \cdot A_s)^b - B - \left(\frac{e}{y_p}\right) \cdot (y - T_1 \cdot A_s \cdot y_p) & y < T_2 \cdot A_s \\ f \cdot A_s^{0.5} - 0,75 \cdot A_s - B & y > T_2 \cdot A_s \end{cases} \quad (11)$$

where:

$$B = c \cdot \left(\frac{T_1 \cdot A_s - A_s \cdot y_p}{A_s \cdot y_p}\right)^d$$

The best fit and the fitting parameters can be seen in respectively figure 17 and table 4

a	1.2188
b	0.28374
c	0.12513
d	0.9803
e	0.10843
f	2.0885

Table 4: Fitting parameters for the best fit to model 6.

To make one mathematical formulation for respectively soft and medium clay, each fitting parameter is plotted against  $\sigma'_1$ , to find one expression that describes a single parameter, which is shown for the a-parameter for soft clay in figure 18.

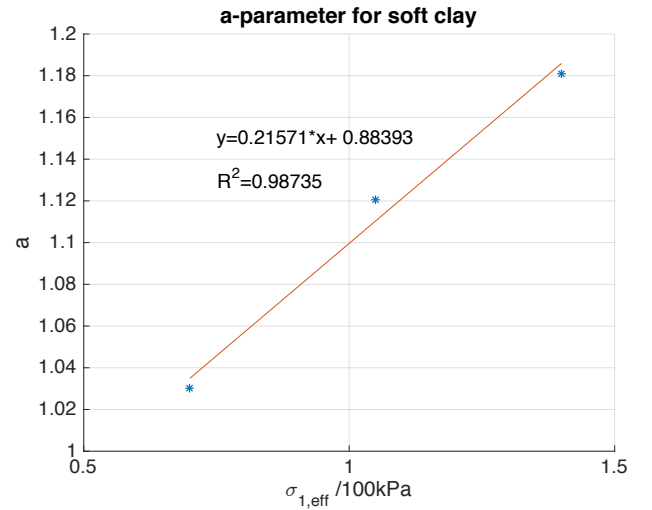

Figure 18: Description for a-parameter.

The mathematical formulation can now be plotted against the raw data and the best fit, as seen in figure 19, where the fitting parameters are determined by eq. 12 for soft clay and eq. 13 for medium clay.

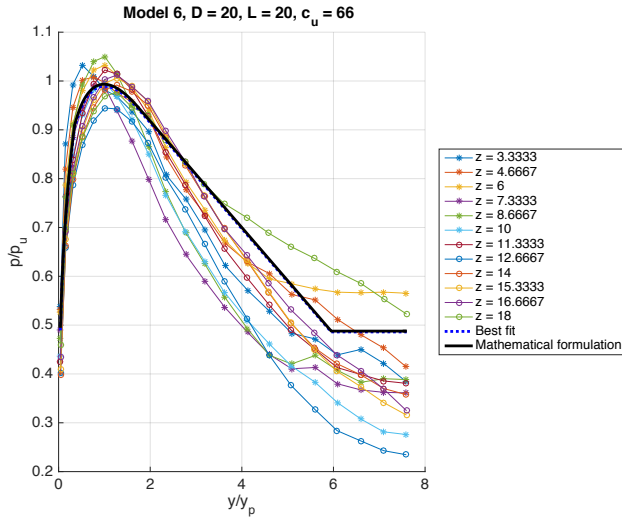

Figure 19: Mathematical formulation.

$$\text{soft clay} \begin{cases} a = 0.21571 \cdot x + 0.88393 \\ b = 0.037957 \cdot x + 0.24483 \\ c = 0.14248 \cdot x - 0.035626 \\ d = -0.45671 \cdot x + 1.8703 \\ e = 0.042507 \cdot x + 0.058906 \\ f = 0.12129 \cdot x + 1.5847 \end{cases} \quad (12)$$

$$\text{Medium clay} \begin{cases} a = 0.041319 \cdot x + 0.1, 1477 \\ b = 0.044769 \cdot x + 0.20007 \\ c = 0.0057473 \cdot x + 0.11467 \\ d = 0.031703 \cdot x + 0.92231 \\ e = -0.010308 \cdot x + 0.12753 \\ f = 0.21297 \cdot x + 1.7035 \end{cases} \quad (13)$$

where:

$$x = \frac{\sigma'_1}{100kPa}$$

## 6 Conclusion

By using the finite element program PLAXIS 3D, it was possible to make numerical models to describe the bearing capacity, for bucket foundations in soft and medium clay, to a prescribed displacement. From the calculated p-y curves it was possible to determine a mathematical formulation, which can be used to make an analytical calculation of the bearing capacity of a bucket foundation with arbitrary dimensions placed in an arbitrary soft or medium clay.

The mathematical formulations are based on three numerical models each, so a natural place to start is calculating some more models with other dimensions, to optimize the formulations with respect to the dimensions. Furthermore, the mathematical formulations have to be studied for other soft and medium clays to optimize the dependency for the strength and stiffness, because there is not a final definition of then a clay is soft or medium.

## References

- Brinkgreve, Kumarswamy, and Swolfs, 2016.** R.B.J. Brinkgreve, S. Kumarswamy, and W.M. Swolfs. *Manual for PLAXIS 3D 2016*, 2016.
- Hvidberg, 2017.** Mogens Bonde Hvidberg. *Bestemmelse af ny p-y formulering for bøttefundamenter i ler vha. Finite element modellering*, 2017.
- Matlock, 1970.** H. Matlock. *Correlation for Design of Laterally Loaded Piles in Soft Clays*. Proceeding of the 2nd Annual OTC. Dallas, Texas., 1970.
- Meyer and Reese, 1979.** Barry J. Meyer and Lymon C. Reese. *Analysis of single piles under lateral loading*, 1979.
- Steenfelt and Sørensen, 2013.** Jørgen S. Steenfelt and Carsten S. Sørensen. *Teknisk Staabi*. Nyt Teknisk Forlag, 22. edition, 2013.
- Vaitkunaite, 2012.** Evelina Vaitkunaite. *Guidelines for length of extended interfaces for bucket foundations*. 2012.
- Østergaard, Knudsen, and Ibsen, 2015.** Martin Underlin Østergaard, Bjørn Staghøj Knudsen, and Lars Bo Ibsen. *P-y curves for bucket foundations in sand using finite element modeling*. 2015. in V. Meyer (ed.), *Frontiers in Offshore Geotechnics III* proceedings of the third international symposium on frontiers in offshore geotechnics (isfog 2015), Oslo, Norway, 10-12 June 2015. vol. 1, C R C Press LLC, London, pp. 343-348.

